

EZS2 Secondary Belt Cleaner

Installation, Operation and Maintenance Manual



Rockline® EZS2 Secondary Belt Cleaner

Serial Number: _____
Purchase Date: _____
Purchased From: _____
Installation Date: _____

Serial number information can be found on the Serial Number Label included in the Information Packet found in the cleaner carton.

This information will be helpful for any future inquiries or questions about belt cleaner replacement parts, specifications or troubleshooting.

Table of Contents

Section 1 – Important Information	2
1.1 General Introduction	2
1.2 User Benefits	2
1.3 Service Option	2
Section 2 – Safety Considerations and Precautions	3
2.1 Stationary Conveyors.....	3
2.2 Operating Conveyors	3
Section 3 – Pre-Installation Checks and Options.....	4
3.1 Checklist	4
Section 4 – Installation Instructions.....	5
Section 5 – Pre-Operation Checklist and Testing.....	7
5.1 Pre-Op Checklist	7
5.2 Test Run the Conveyor	7
Section 6 – Maintenance	8
6.1 New Installation Inspection	8
6.2 Routine Visual Inspection	8
6.3 Routine Physical Inspection.....	8
6.4 Blade Replacement Instructions.....	9
6.5 Maintenance Log	11
6.6 Cleaner Maintenance Checklist.....	12
Section 7 – Troubleshooting	13
Section 8 – Specs and CAD Drawings.....	14
8.1 Specifications and Guidelines	14
8.2 CAD Drawings.....	15
Section 9 – Replacement Parts	17
Section 10 – Other Flexco Conveyor Products.....	18

Section 1 – Important Information

1.1 General Introduction

We at Flexco are very pleased that you have selected an EZS2 Secondary Belt Cleaner for your conveyor system.

This manual will help you to understand the operation of this product and assist you in making it work up to its maximum efficiency over its lifetime of service.

It is essential for safe and efficient operation that the information and guidelines presented be properly understood and implemented. This manual will provide safety precautions, installation instructions, maintenance procedures and troubleshooting tips.

If, however, you have any questions or problems that are not covered, please visit our web site or contact our Customer Service Department:

Web site: Flexco.com

Customer Service: USA: 1-800-541-8028

Visit www.flexco.com for other Flexco locations and products.

Please read this manual thoroughly and pass it on to any others who will be directly responsible for installation, operation and maintenance of this cleaner. While we have tried to make the installation and service tasks as easy and simple as possible, **it does however require correct installation and regular inspections and adjustments to maintain top working condition.**

1.2 User Benefits

Correct installation and regular maintenance will provide the following benefits for your operation:

- Reduced conveyor downtime
- Reduced man-hour labor
- Lower maintenance budget costs
- Increased service life for the belt cleaner and other conveyor components

1.3 Service Option

The EZS2 Secondary Belt Cleaner is designed to be easily installed and serviced by your on-site personnel. However, if you would prefer complete turn-key factory service, please contact your local Flexco Field Representative.

Section 2 – Safety Considerations and Precautions

Before installing and operating the EZS2 Secondary Belt Cleaner, it is important to review and understand the following safety information.

There are set-up, maintenance and operational activities involving both **stationary** and **operating** conveyors. Each case has a safety protocol.

2.1 Stationary Conveyors

The following activities are performed on stationary conveyors:

- Installation
- Blade replacement
- Repairs
- Tension adjustments
- Cleaning

DANGER

It is imperative that OSHA/MSHA Lockout/Tagout (LOTO) regulations, 9 CFR 1910.147, be followed before undertaking the preceding activities. Failure to use LOTO exposes workers to uncontrolled behavior of the belt cleaner caused by movement of the conveyor belt. Severe injury or death can result.

Before working:

- Lockout/Tagout the conveyor power source
- Disengage any takeups
- Clear the conveyor belt or clamp securely in place

WARNING

Use Personal Protective Equipment (PPE):

- Safety eyewear
- Hardhats
- Safety footwear

Close quarters, springs and heavy components create a worksite that compromises a worker's eyes, feet and skull.

PPE must be worn to control the foreseeable hazards associated with conveyor belt cleaners. Serious injuries can be avoided.

2.2 Operating Conveyors

There are two routine tasks that must be performed while the conveyor is running:

- Inspection of the cleaning performance
- Dynamic troubleshooting

DANGER

Every belt cleaner is an in-running nip hazard. Never touch or prod an operating cleaner. Cleaner hazards cause instantaneous amputation and entrapment.

WARNING

Belt cleaners can become projectile hazards. Stay as far from the cleaner as practical and use safety eyewear and headgear. Missiles can inflict serious injury.

WARNING

Never adjust anything on an operating cleaner. Unforeseeable belt projections and tears can catch on cleaners and cause violent movements of the cleaner structure. Flailing hardware can cause serious injury or death.

Section 3 – Pre-installation Checks and Options

3.1 Checklist

- Check that the cleaner size is correct for the beltline width
- Check the belt cleaner carton and make sure all the parts are included
- Review the “Tools Needed” list on the top of the installation instructions
- Check the conveyor site:
 - Will the cleaner be installed on a chute
 - Is the install on an open head pulley requiring mounting structure

Section 4 – Installation Instructions

4.1 EZS2 Secondary Belt Cleaner

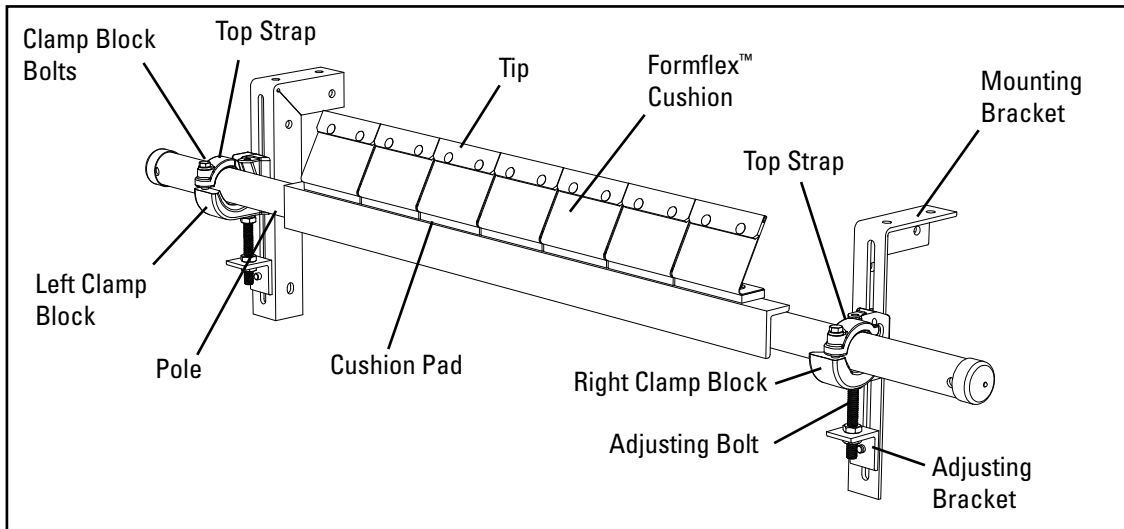

Physically lock out and tag the conveyor at the power source before you begin cleaner installation.

Tools Needed:

- Tape measure
- (2) 3/4" (19mm) wrench or crescent wrench

1. **Install the mounting brackets.** Determine the correct clamp block (left or right) and bracket needed for each side of the conveyor. The top strap should be offset away from the belt (you should be able to see the notch for the top strap from the outside of the conveyor). (Fig. 1a). Position the mounting bracket to locate the cleaner pole centerline 7" (175mm) below the beltline. The pole must be installed so the blades do not touch the belt. Positioning the brackets perpendicular to the belt is recommended (Fig.1b).

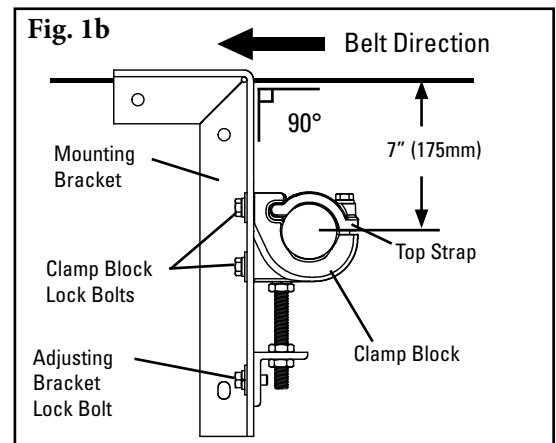
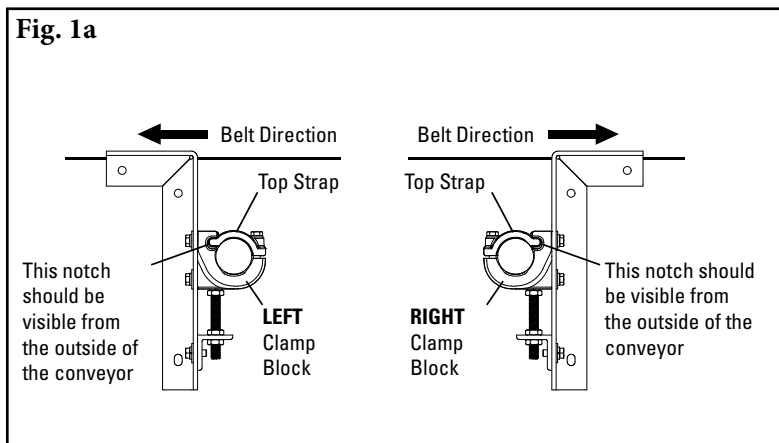
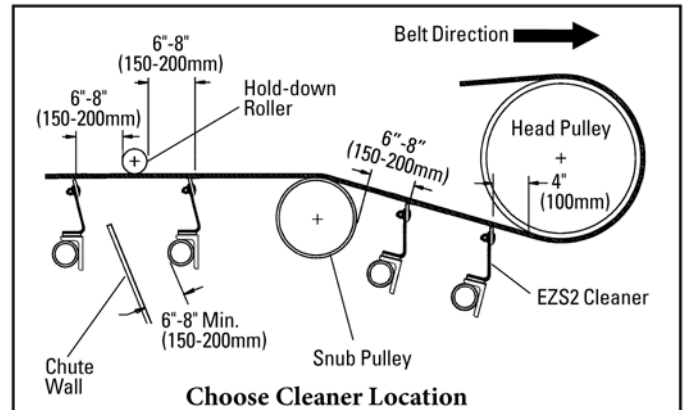

Section 4 – Installation Instructions

4.1 EZS2 Secondary Belt Cleaner (cont.)

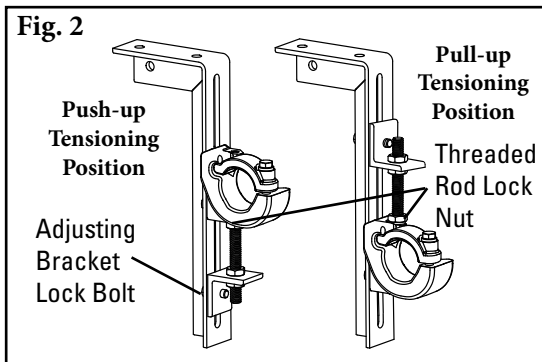

2. **Choose the tensioner position.** The tensioner is shipped mounted in the push-up position. Depending upon the space constraints of the installation, the tensioner can be optionally mounted in a pull-up position. To do this, loosen the threaded rod lock nut, unscrew the threaded rod and remove adjusting bracket lock bolt. Then move the adjusting bracket and threaded rod to the top of the clamp blocks (Fig. 2) and tighten threaded rod lock nut.

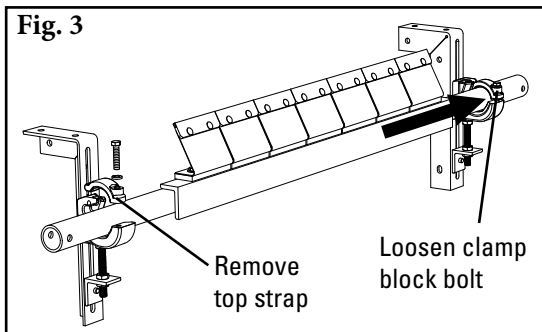

3. **Install the pole.** Remove the clamp block top strap on one side, and on the opposite side loosen the clamp block bolt. Slide the pole across and into the loosened clamp block, replace the top strap on the clamp block, center the blades on the belt and tighten both clamp block bolts finger tight.

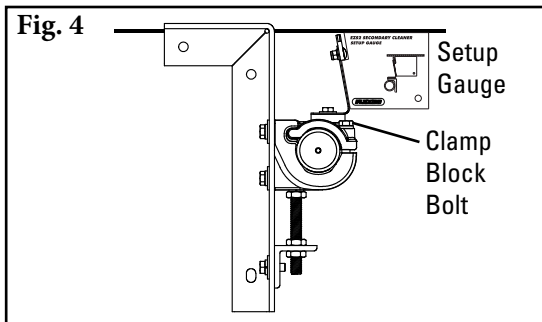

4. **Set the blade angle.** With the gauge provided, rotate the pole so the blades are set at the correct angle. Lock the pole in place by tightening the clamp block bolts (Fig. 4).

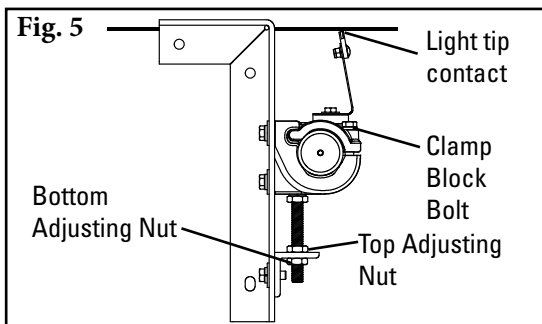

5. **Set the blade tension.** Loosen the 4 clamp block lock bolts (on the back of the mounting brackets) and turn the top adjusting jam nut on each side until the blades make light contact across the entire width of the belt. Make an additional 1 full turn on the adjusting nuts to tension the blades. Tighten the bottom adjusting nuts and the clamp block bolts (Fig. 5).

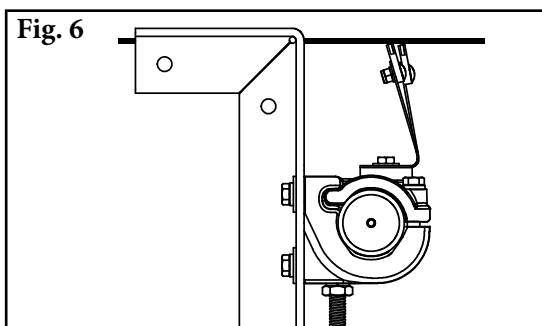

6. **Check the blade tension.** Pull back on the outside blade until it breaks contact with the belt and release (Fig.6). If the blades are correctly tensioned, the complete tip of the adjacent blade will be visible. If it is not, make a tension adjustment as instructed in Step 5.

Test run the cleaner and inspect the performance. If vibration occurs, the pole can be rotated to lay the cushion/blade back another 5° to 10° and then the blades must be retensioned. If more cleaning efficiency is desired, the blade tension can be increased in 1/4 turns on the adjusting nuts (see Step 5).

Section 5 – Pre-Operation Checklist and Testing

5.1 Pre-Op Checklist

- Recheck that all fasteners are tightened properly
- Add pole caps
- Apply all supplied labels to the cleaner
- Check the blade location on the belt
- Be sure that all installation materials and tools have been removed from the belt and the conveyor area

5.2 Test Run the Conveyor

- Run the conveyor for at least 15 minutes and inspect the cleaning performance
- Check the tensioner spring for recommended length (proper tensioning)
- Make adjustments as necessary

NOTE: Observing the cleaner when it is running and performing properly will help to detect problems or when adjustments are needed later.

Section 6 – Maintenance

Flexco belt cleaners are designed to operate with minimum maintenance. However, to maintain superior performance some service is required. When the cleaner is installed a regular maintenance program should be set up. This program will ensure that the cleaner operates at optimal efficiency and problems can be identified and fixed before the cleaner stops working.

All safety procedures for inspection of equipment (stationary or operating) must be observed. The EZS2 Secondary Belt Cleaner operates at the discharge end of the conveyor and is in direct contact with the moving belt. Only visual observations can be made while the belt is running. Service tasks can be done only with the conveyor stopped and by observing the correct lockout/tagout procedures.

6.1 New Installation Inspection

After the new cleaner has run for a few days a visual inspection should be made to ensure the cleaner is performing properly. Make adjustments as needed.

6.2 Routine Visual Inspection (every 2-4 weeks)

A visual inspection of the cleaner and belt can determine:

- If adjusting brackets are set for optimal tensioning.
- If the belt looks clean or if there are areas that are dirty.
- If the blade is worn out and needs to be replaced.
- If there is damage to the blade or other cleaner components.
- If fugitive material is built up on the cleaner or in the transfer area.
- If there is cover damage to the belt.
- If there is vibration or bouncing of the cleaner on the belt.
- If a snub pulley is used, a check should be made for material buildup on the pulley.
- Significant signs of carryback.

If any of the above conditions exist, a determination should be made on when the conveyor can be stopped for cleaner maintenance.

6.3 Routine Physical Inspection (every 6-8 weeks)

When the conveyor is not in operation and properly locked and tagged out a physical inspection of the cleaner to perform the following tasks:

- Clean material buildup off of the cleaner blade and pole.
- Closely inspect the blade for wear and any damage. Replace if needed.
- Ensure full blade to belt contact.
- Inspect the cleaner pole for damage.
- Inspect all fasteners for tightness and wear. Tighten or replace as needed.
- Replace any worn or damaged components.
- Check the tension of the cleaner blade to the belt. Adjust the tension if necessary using the steps on page 6
- When maintenance tasks are completed, test run the conveyor to ensure the cleaner is performing properly.

Section 6 – Maintenance

6.4 Blade Replacement Instructions

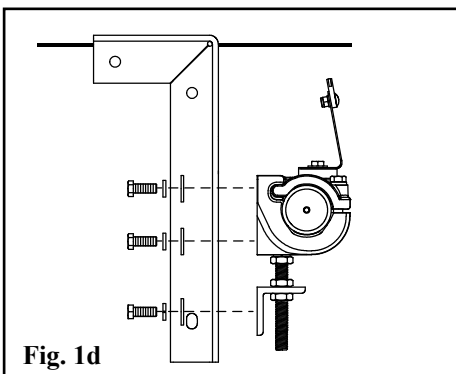
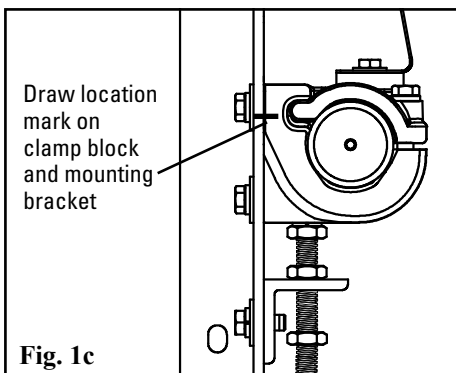
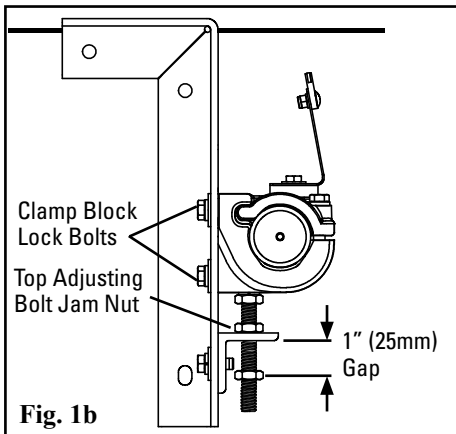
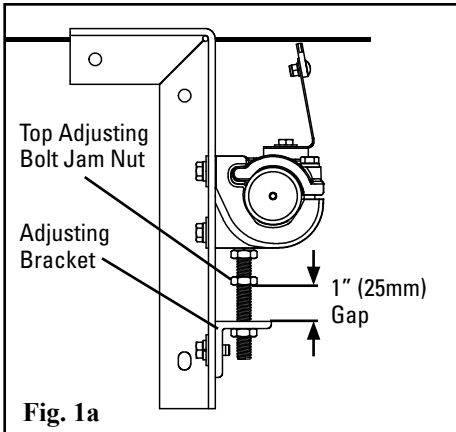

BEFORE YOU BEGIN:

PHYSICALLY LOCK OUT AND TAG THE CONVEYOR AT THE POWER SOURCE.

1. Release the blade tension and remove worn blade tips.

- Loosen and turn the top adjusting bolt jam nuts 1" (25mm) above the tops of the adjusting brackets (Fig. 1a).
- Loosen the clamp block lock bolts on both sides and allow the pole to move down and rest on the raised top adjusting bolt jam nuts (Fig. 1b).
- Place location marks across the mounting bracket and the clamp block for quick repositioning after blade replacement (Fig. 1c).
- Remove the clamp block lock bolts and adjusting bracket lock bolts on each side and remove the pole with the clamp blocks and adjusting brackets attached (Fig. 1d).
- Remove the nuts, flat washers and lock washers from the tips and remove the worn tips (Fig. 1e).
- Insert new blade tips and install flat washers, lock washers and nuts finger tight. Buff the outside corners of the last tip on each side of the cleaner (Fig. 1f).

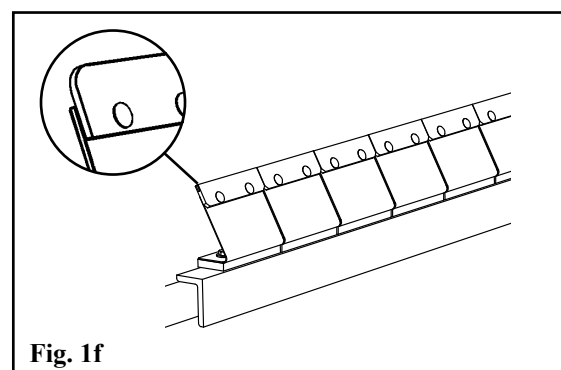
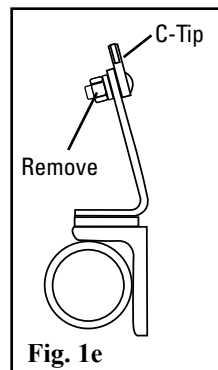

Section 6 – Maintenance

6.4 Blade Replacement Instructions (C-Tips) (cont.)

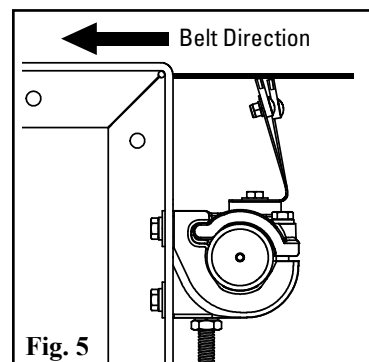
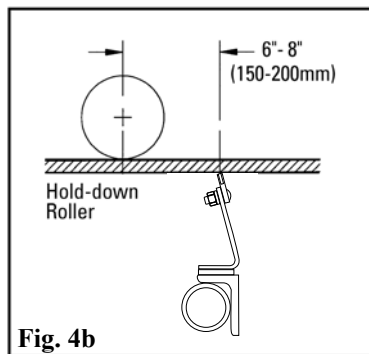
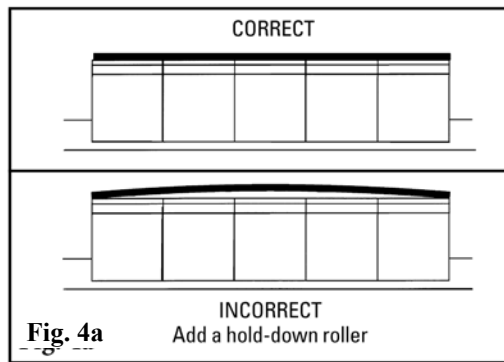
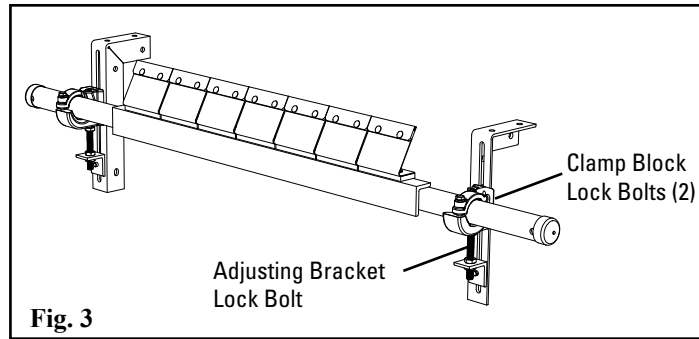
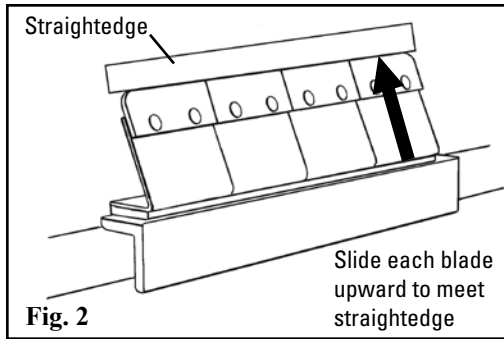

- Align the blade tips.** Push tips together so there is no more than a .010" to .015" gap between them. Position a straightedge along the top surface of new blade tips. Pull upward on each blade to align with the bottom of the straightedge and tighten the nuts (Fig. 2).
 - Reinstall the pole.** Slide the pole back into position on the mounting brackets, aligning the marks made on the bracket and clamp block. Install the two adjusting bracket lock bolts and tighten. Install the four clamp block lock bolts finger tight (Fig. 3).
 - Set the blade tension.** Turn the top adjusting bolt jam nuts down until light tip to belt contact is made across the entire width of the cleaner. Add an additional 1½ turns on the top adjusting bolt jam nuts and lock the bottom adjusting bolt jam nuts. Tighten all clamp block lock bolts.
- NOTE:** If the belt is cupped, do not overtension the blades to contact the belt. A hold-down roller should be installed to flatten the belt (Fig. 4a and 4b). (Try the Stabilizing Return Roller or Stabilizing Roller Bracket Kit).
- Check the blade tip tension.** Pull back on the outer blade in the direction of belt travel until the blade breaks contact with the belt. Let go of the blade. With correct tension the full thickness of the adjacent blade tip should be visible in front of the outer blade (Fig. 5). Also check the center blade in same manner. Add tension in 1/2-turn increments on the top adjusting bolt jam nuts until view of full thickness of the adjacent blade tip is achieved.

- Test run cleaner and inspect operation.** If vibration occurs, increase tip tension by making 1/2-turn adjustments.

Section 6 – Maintenance

6.5 Maintenance Log

Conveyor Name/No. _____

Date: _____ Work done by: _____ Service Quote # _____

Activity: _____

Date: _____ Work done by: _____ Service Quote # _____

Activity: _____

Date: _____ Work done by: _____ Service Quote # _____

Activity: _____

Date: _____ Work done by: _____ Service Quote # _____

Activity: _____

Date: _____ Work done by: _____ Service Quote # _____

Activity: _____

Date: _____ Work done by: _____ Service Quote # _____

Activity: _____

Date: _____ Work done by: _____ Service Quote # _____

Activity: _____



Section 6 – Maintenance

6.6 Cleaner Maintenance Checklist

Site: _____ Inspected by: _____ Date: _____

Belt Cleaner: _____ Serial Number: _____

Beltline Information:

Beltline Number: _____ Belt Condition: _____

Belt Width: 18" 24" 30" 36" 42" 48" 54" 60" 72"
(450mm) (600mm) (750mm) (900mm) (1050mm) (1200mm) (1350mm) (1500mm) (1800mm)

Head Pulley Diameter (*Belt & Lagging*): _____ Belt Speed: _____ fpm Belt Thickness: _____

Belt Splice _____ Condition of Splice _____ Number of splices _____ Skived Unskived

Material conveyed _____

Days per week run _____ Hours per day run _____

Blade Life:

Date blade installed: _____ Date blade inspected: _____ Estimated blade life: _____

Is blade making complete contact with belt? Yes No

Distance from wear line: LEFT _____ MIDDLE _____ RIGHT _____

Blade condition: Good Not contacting belt Damaged

Measurement of spring: Required _____ Currently _____

Was Cleaner Adjusted: Yes No

Pole Condition: Good Bent Worn

Lagging: Slide lag Ceramic Rubber Other None

Condition of lagging: Good Bad Other _____

Cleaner's Overall Performance: (Rate the following 1 - 5, 1 = very poor - 5 = very good)

Appearance: Comments: _____

Location: Comments: _____

Maintenance: Comments: _____

Performance: Comments: _____

Other Comments: _____

Section 7 – Troubleshooting

Problem	Possible Cause	Possible Solutions
Vibration	Cleaner secure bolts not set	Ensure all locking nuts are tight (Loctite)
	Cleaner not set up correctly	Ensure cleaner set up properly (1°-3° into belt)
	Belt tension too high	Ensure cleaner can conform to belt, or replace with alternate Flexco secondary cleaner
	Belt flap	Introduce hold-down roller to flatten belt
	Cleaner over-tensioned	Ensure cleaner is correctly tensioned
	Cleaner under-tensioned	Ensure cleaner is correctly tensioned
Material buildup on cleaner	Cleaner not set up correctly	Ensure cleaner set up properly (1°-3° into belt)
	Buildup on chute	Ensure cleaner is not located too close to back of chute, allowing buildup
	Cleaner being overburdened	Introduce Flexco precleaner
	Excessive sticky material	Frequently clean unit of buildup
Damaged belt cover	Cleaner over-tensioned	Ensure cleaner is correctly tensioned
	Cleaner blade damage	Check blade for wear, damage and chips, replace where necessary
	Attack angle not correct	Ensure cleaner set up properly (1°-3° into belt)
	Material buildup in chute	Frequently clean unit of buildup
Cleaner not conforming to belt	Cleaner not set up correctly	Ensure cleaner set up properly (1°-3° into belt)
	Belt tension too high	Ensure cleaner can conform to belt, or replace with alternate Flexco secondary cleaner
	Belt flap	Introduce hold-down roller to flatten belt
	Cleaner cannot conform	Ensure cleaner can conform to belt, or replace with alternate Flexco secondary cleaner
Material passing cleaner	Cleaner not set up correctly	Ensure cleaner set up properly (1°-3° into belt)
	Cleaner tension too low	Ensure cleaner is correctly tensioned
	Cleaner blade worn/damaged	Check blade for wear, damage and chips, replace where necessary
	Cleaner being overburdened	Introduce Flexco precleaner
	Belt flap	Introduce hold-down roller to flatten belt
	Belt wear	
	Cleaner cannot conform	Ensure cleaner can conform to belt, or replace with alternate Flexco secondary cleaner
	Blade in backwards	Install blade correctly and set correct tension
Damage to mechanical fastener	Incorrect cleaner blade selection	Change blade type to accommodate fastener style (C or V)
	Belt not skived correctly	Spot and redo splice correctly, lowering the profile flush or below belt surface
Missing material in belt center only	Cleaner pole located too high	Ensure cleaner set up properly (1°-3° into belt)
	Cleaner blade worn/damaged	Check blade for wear, damage and chips, replace where necessary
Missing material on outer edges only	Cleaner pole located too low	Ensure cleaner set up properly (1°-3° into belt)
	Cleaner blade worn/damaged	Check blade for wear, damage and chips, replace where necessary

Section 8 – Specs and CAD Drawings

8.1 Specifications and Guidelines

Pole Length Specifications

Belt Width		Blade Width		Pole Length		Maximum Conveyor Span	
in.	mm	in.	mm	in.	mm	in.	mm
18	450	18	450	52	1300	47	1175
24	600	24	600	58	1450	53	1325
30	750	30	750	64	1600	59	1475
36	900	36	900	70	1750	65	1625
42	1050	42	1050	76	1900	71	1775
48	1200	48	1200	82	2050	77	1925
54	1350	54	1350	88	2200	83	2075
60	1500	60	1500	94	2350	89	2225
72	1800	72	1800	106	2650	101	2525

Pole Diameter - 2 3/8" (60mm)

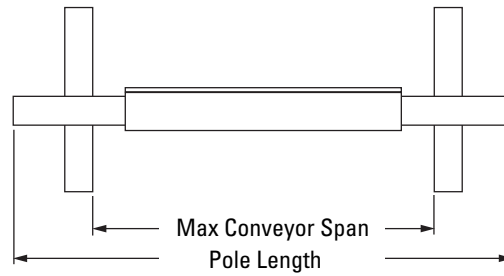

Clearance Guidelines for Installation

Horizontal Clearance Required		Vertical Clearance Required	
in.	mm	in.	mm
4	100	8 1/2 for 18"-54"	213
		9 1/2 for 60"-72"	238

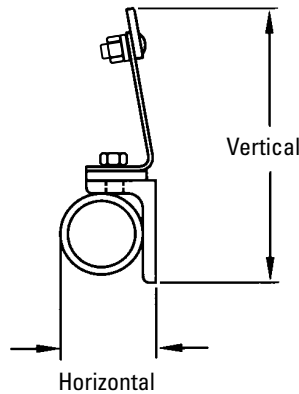

Specifications:

- Maximum Belt Speed.....700 FPM (3.5M/sec)
- Temperature Rating.....-30°F to 200°F (-35°C to 93°C)
HT.....-30°F to 400°F (-35°C to 205°C)
- Usable Blade Wear Length.....3/8" (9mm)
- Blade Material.....Impact Resistant Tungsten Carbide
(works with mechanical fasteners)
- Available for Belt Widths.....18" to 72" (450 to 1800mm)
- CEMA Cleaner Rating.....Class 3

U.S. Patent No. 6,823,983

Section 8 – Specs and CAD Drawings

8.2 CAD Drawing – EZS2 with C-Tips

SPECIFICATIONS			EZS2 SECONDARY CLEANER	
BELT WIDTH 'A' (in)	POLE LENGTH 'B' (in)	NUMBER OF TIPS	ORDER NUMBER	ITEM CODE
18	52	3	EZS2-18	75643
24	58	4	EZS2-24	75644
30	64	5	EZS2-30	75645
36	70	6	EZS2-36	75646
42	76	7	EZS2-42	75647
48	82	8	EZS2-48	75648
54	88	9	EZS2-54	75649
60	94	10	EZS2-60	75650
72	106	12	EZS2-72	75651

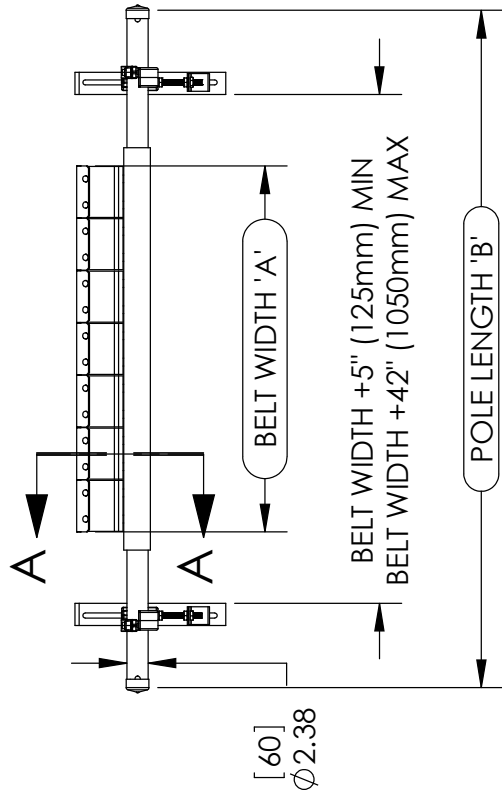
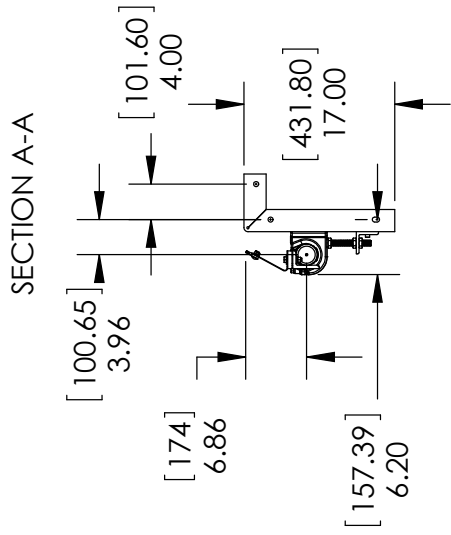
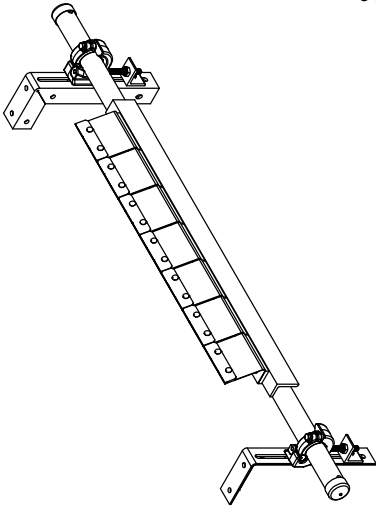

Section 8 – Specs and CAD Drawings (cont.)

8.2 CAD Drawing – EZS2 Hi Temp

SPECIFICATIONS			EZS2 SECONDARY CLEANER	
BELT WIDTH 'A' (in)	POLE LENGTH 'B' (in)	NUMBER OF TIPS	ORDER NUMBER	ITEM CODE
18	52	3	HTS18	76085
24	60	4	HTS24	76086
30	75	5	HTS30	76087
36	90	6	HTS36	76088
42	105	7	HTS42	76089
48	120	8	HTS48	76090
54	135	9	HTS54	76091
60	150	10	HTS60	76092
72	180	12	HTS72	76093

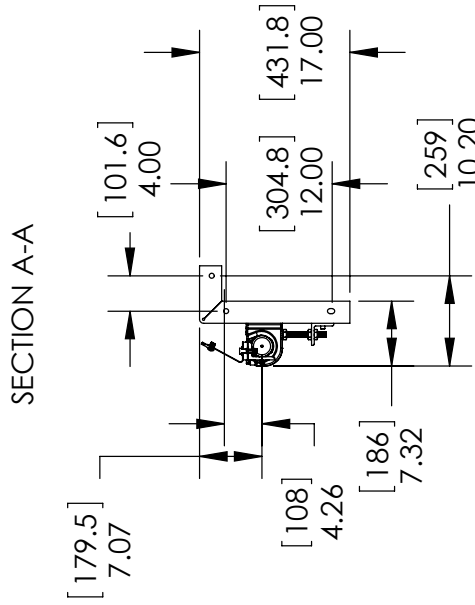
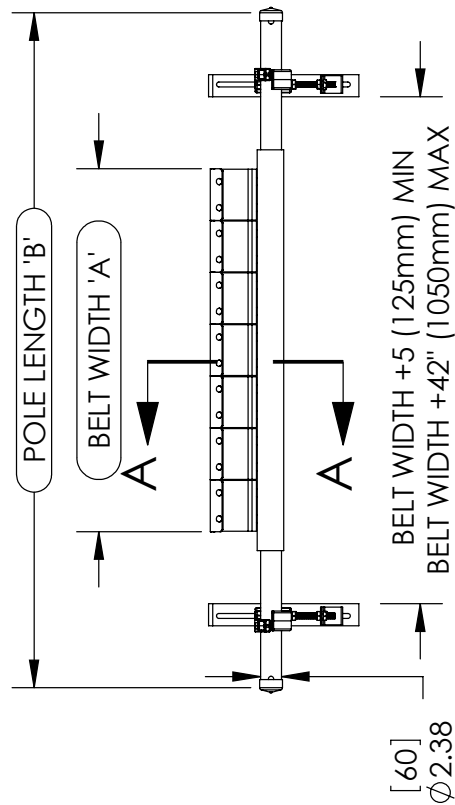
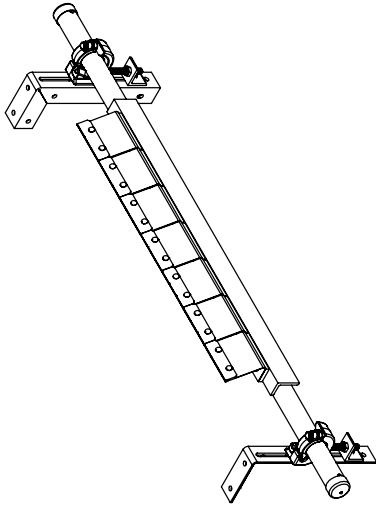

Section 9 – Replacement Parts

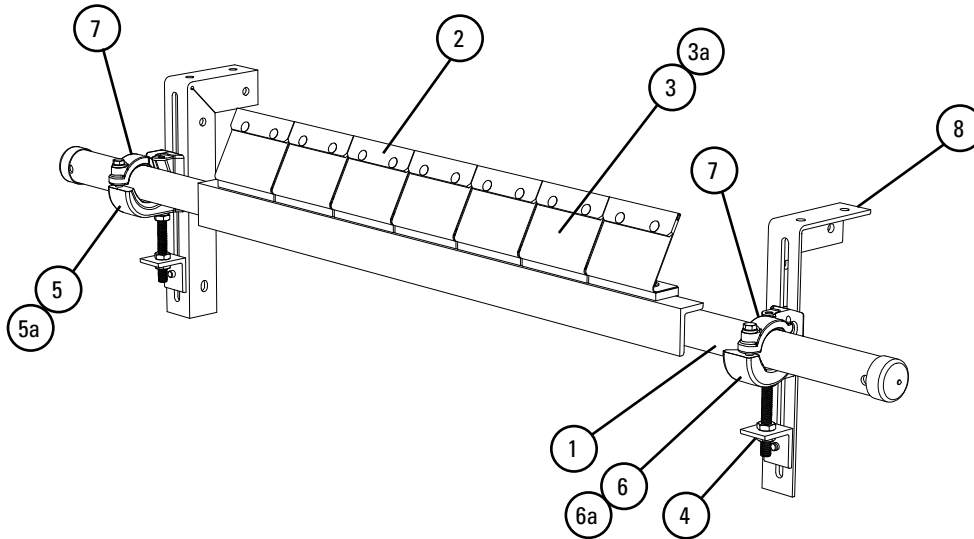

Replacement Parts

Ref	Description	Ordering Number	Item Code	Wt. Lbs.
1	18" (450mm) Pole	EZS2P18	75652	25.0
	24" (600mm) Pole	EZS2P24	75653	28.0
	30" (750mm) Pole	EZS2P30	75654	30.0
	36" (900mm) Pole	EZS2P36	75655	34.0
	42" (1050mm) Pole	EZS2P42	75656	36.0
	48" (1200mm) Pole	EZS2P48	75657	39.0
	54" (1350mm) Pole	EZS2P54	75658	42.0
	60" (1500mm) Pole	EZS2P60	75659	77.0
	72" (1800mm) Pole	EZS2P72	75660	89.0
2	C-Tip Kit* (1 ea.)	ICT6	74535	0.7
3	FormFlex™ Cushion Kit* (incl. 1 cushion & 1 pad)	FFCK	75661	1.5
3a	High Temp Replacement Cushion Kit (incl. 1 cushion & 1 pad)	HTSCK	76094	1.5
4	Adjusting Bracket Kit* (1 ea.)	PAB	75513	1.5
5	Pole Clamp Kit LEFT* (1 ea.) (incl. item 7) for sizes 18"-54" (450-1350mm)	CCKL	79224	6.8
5a	HD Pole Clamp Kit LEFT* (1 ea.) (incl. item 7a) for sizes 60"-72" (1500-1800mm)	CCKHDL	79225	8.7
6	Pole Clamp Kit RIGHT* (1 ea.) (incl. item 7) for sizes 18"-54" (450-1350mm)	CCKR	79228	6.8
6a	HD Pole Clamp Kit RIGHT* (1 ea.) (incl. item 7a) for sizes 60"-72" (1500-1800mm)	CCKHDR	79229	8.7
7	Cradle Clamp Top Strap (1 ea.) for use on L or R Pole Clamp Kit	CCKTS	79232	1.1
7a	HD Cradle Clamp Top Strap (1 ea.) for use on L or R HD Pole Clamp Kit	CCKHDT	79233	1.7
8	Mounting Bracket Kit (1 Right and 1 Left)	EZS2MBK	75666	13.0
-	Cradle Clamp Mounting Kit* for sizes 18"-54" (450-1350mm) (incl. 2 ea. Items 4 and 1 ea. Items 5, 6 & 8)	CCMK	78919	33.0
-	HD Cradle Clamp Mounting Kit* for sizes 60"-72" (1500-1800mm) (incl. 2 ea. Items 4 and 1 ea. Items 5a, 6a & 8)	CCMKHD	78920	36.7

*Hardware Included Lead time: 1 working day

Mounting Kit Selection Chart

Cleaner Width	78919 CCMK	78920 CCMKHD
EZS2 18" - 54" (450 - 1350mm)	X	
EZS2 60" - 72" (1500 - 1800mm)		X

Cleaner Tips and Cushions Required Per Cleaner Size

in.	mm	Tips Required
18	450	3
24	600	4
30	750	5
36	900	6
42	1050	7
48	1200	8
54	1350	9
60	1500	10
72	1800	12

Section 10 – Other Flexco Conveyor Products

Flexco provides many conveyor products that help your conveyors to run more efficiently and safely. These components solve typical conveyor problems and improve productivity. Here is a quick overview on just a few of them:

Rockline® EZP1 Precleaner



- Patented ConShear™ blade renews its cleaning edge as it wears
- Visual Tension Check™ for optimal blade tensioning and simple retensioning
- Quick and easy one-pin blade replacement Material Path Option™ for optimal cleaning and reduced maintenance

DRX Impact Beds



- Exclusive Velocity Reduction Technology™ to better protect the belt
- Slide-Out Service™ gives direct access to all impact bars for change-out
- Impact bar supports for longer bar life
- 4 models to custom fit to the application

Flexco Secondary Belt Cleaners



- Long-wearing metal blades for superior cleaning efficiency
- Individually mounted blades for consistent cleaning power
- Easy to install, simple to service
- Works with Flexco mechanical belt splices

PT Max™ Belt Trainer

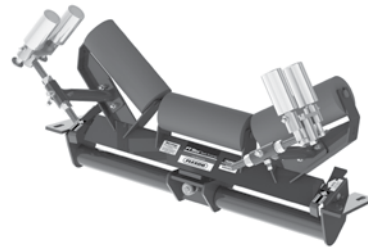

- Patented “pivot & tilt” design for superior training action
- Dual sensor rollers on each side to minimize belt damage
- Pivot point guaranteed not to freeze or seize up
- Available for topside and return side belts

Flexco Specialty Belt Cleaners



- “Limited space” cleaners for tight conveyor applications
- High Temp cleaners for severe, high heat applications
- A rubber-fingered cleaner for chevron and raised-rib belts
- Multiple cleaner styles in stainless steel for corrosive applications

Belt Plows



- A belt cleaner for the tail pulley
- Exclusive blade design quickly spirals debris off the belt
- Economical and easy to service
- Available in vee or diagonal models





2525 Wisconsin Avenue • Downers Grove, IL 60515-4200 • USA
Tel: (630) 971-0150 • Fax: (630) 971-1180 • E-mail: info@flexco.com

Visit www.flexco.com for other Flexco locations and products.

©2015 Flexible Steel Lacing Company. 11/15. For reorder: X2403

