

MSP

Standard Mine-Duty Precleaner

Economical and Effective

The MSP Standard-Duty Precleaner is not your average solid-blade belt cleaner that mounts on the head pulley. It is a mine-tough design that combines simple, do-it-yourself installation, quick maintenance and effective cleaning results with an affordable price tag.

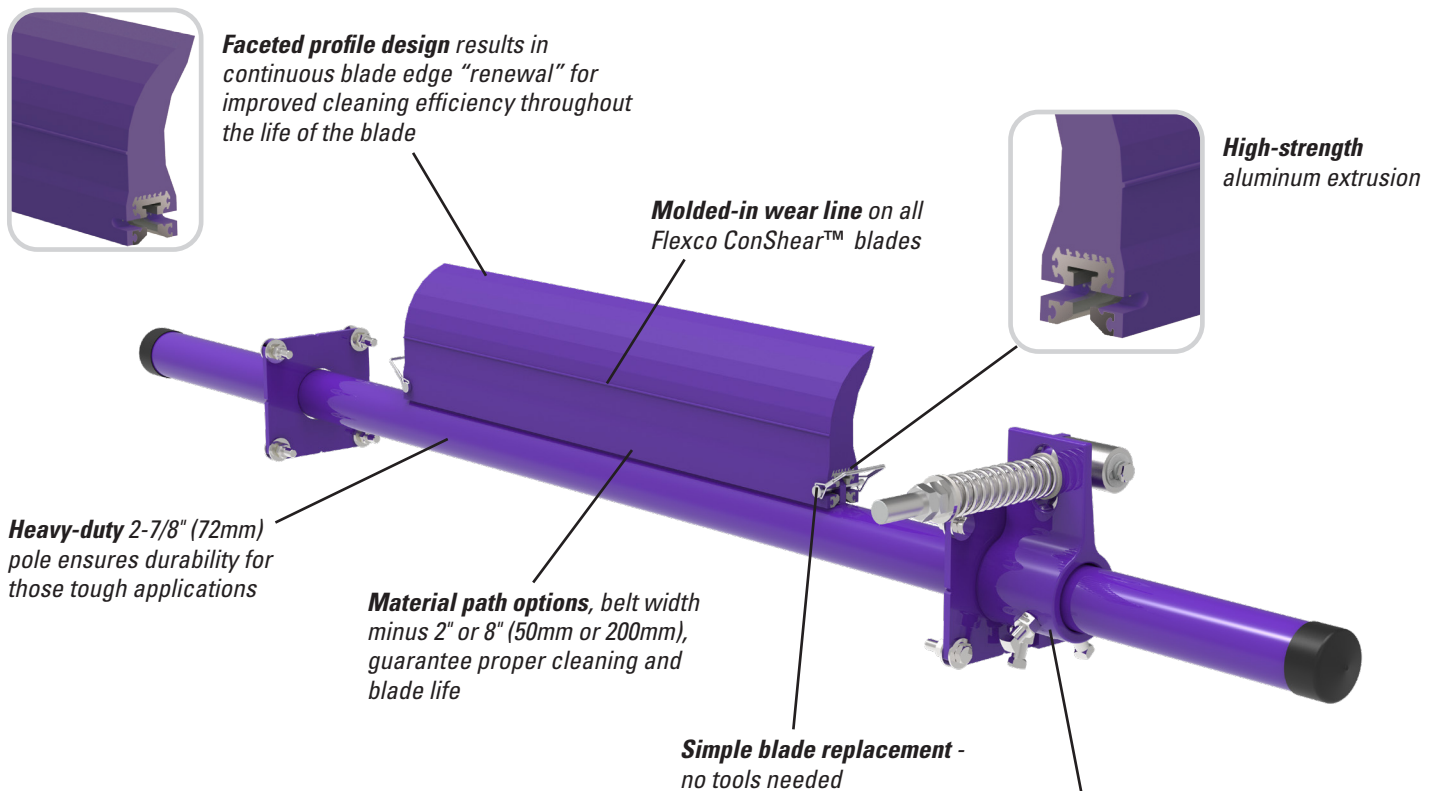

Features and Benefits

- **Quick-change blade.** No tools are needed. Just pull one pin, remove the old blade, slide in the new one and replace the pin.
- **Works with Flexco and other mechanical splices.** The spring tensioner quickly moves the blade away from the belt when a splice passes. The polyurethane blade easily glides over the splice without damage and with minimal cleaning disruption.
- **Easy to service.** All maintenance work is done from the easy-access side of the beltline. Blade retensioning and change-out are quick and easy.
- **Fits most conveyor structures.** Available for belt widths from 24 to 84" (600 to 2100mm). The MSP poles are extra long (belt width plus 54" (1350mm)) to accommodate varying structure widths.

MSP

Standard Mine-Duty Precleaner

Specifications and Guidelines

- **Maximum Belt Speed**
700 FPM (3.5 M/sec)
- **Temperature Rating**
-30 to 180°F (-35 to 82°C)
- **Minimum Pulley Diameter**
16" (400mm)
- **Blade Height**
7-1/4" (185mm)
- **Usable Blade Wear Length**
4" (100mm)
- **Blade Material**
Polyurethane 83 durometer
(proprietary blend for abrasion resistance and long wear)
- **Available for Belt Widths**
24 to 84" (600 to 2100mm)
- **CEMA Cleaner Rating**
Class 3
- **Horizontal Clearance Required**
4" (100mm)
- **Vertical Clearance Required**
10" (254mm)
- **Pole Length**
Cleaner size + 54" (1350mm)
- **Maximum Conveyor Span**
Cleaner size + 44" (1100mm)

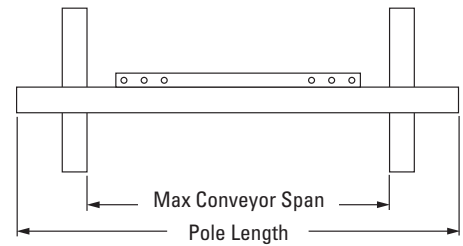
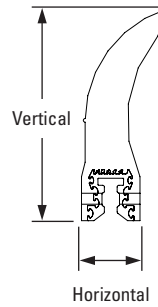

Pole Location Specs

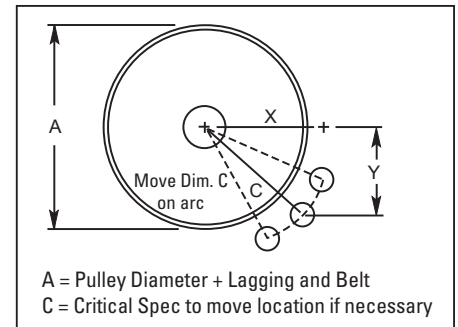

Ordering Information

MSP Precleaner Belt Width Minus 2" (50mm)					
Belt Width		Blade Width		Ordering Number	Item Code
in.	mm	in.	mm		
24	600	22	550	MSP-224	75787
30	750	28	700	MSP-230	75788
36	900	34	850	MSP-236	75789
42	1050	40	1000	MSP-242	75790
48	1200	46	1150	MSP-248	75791
54	1350	52	1300	MSP-254	75792
60	1500	58	1450	MSP-260	75793
72	1800	70	1750	MSP-272	75794
84	2100	82	2050	MSP-284	76796

Belt Width Minus 8" (200mm)					
Belt Width		Blade Width		Ordering Number	Item Code
in.	mm	in.	mm		
24	600	16	400	MSP-824	75795
30	750	22	550	MSP-830	75796
36	900	28	700	MSP-836	75797
42	1050	34	850	MSP-842	75798
48	1200	40	1000	MSP-848	75799
54	1350	46	1150	MSP-854	75800
60	1500	52	1300	MSP-860	75801
72	1800	64	1600	MSP-872	75802
84	2100	76	1900	MSP-884	76797

Lead time: 3 weeks

Replacement ConShear™ Blades			
Blade Width		Ordering Number	Item Code
in.	mm		
10	250	CRB-10	75628
16	400	CRB-16	75629
22	550	CRB-22	75630
28	700	CRB-28	75631
34	850	CRB-34	75632
40	1000	CRB-40	75633
46	1150	CRB-46	75634
52	1300	CRB-52	75635
58	1450	CRB-58	75636
64	1600	CRB-64	75775
70	1750	CRB-70	75773
76	1900	CRB-76	76940
82	2050	CRB-84	76941

Other blade sizes available upon request.
Lead time: 1 working day

Pole Location Chart

A		X		Y		C	
in.	mm	in.	mm	in.	mm	in.	mm
10	250	2 5/8	68	9	230	9 4/8	240
11	275	3 4/8	88	9	230	9 6/8	246
12	300	4	102	9	230	9 7/8	252
13	325	5 1/8	130	9	230	10 3/8	264
14	350	5 5/8	142	9	230	10 5/8	270
15	375	6 4/8	164	9	230	11 1/8	282
16	400	7 1/8	176	9	230	11 1/2	290
17	425	7 7/8	196	9	230	12	302
18	450	8 1/4	204	9	230	12 1/4	308
19	475	9	222	9	230	12 3/4	320
20	500	9 3/8	232	9	230	13	326
21	525	10	248	9	230	13 1/2	338
22	550	10 3/4	266	9	230	14	352
23	575	11 3/8	282	9	230	14 1/2	364
24	600	12	298	9	230	15	376
25	625	12 5/8	312	9	230	15 1/2	388
26	650	13 1/4	330	9	230	16	402
27	675	13 7/8	344	9	230	16 1/2	414
28	700	14 3/8	358	9	230	17	426
29	725	15	372	9	230	17 1/2	438
30	750	15 5/8	390	9	230	18	452
31	775	16 1/8	402	9	230	18 1/2	464
32	800	16 3/4	416	9	230	19	476
33	825	17 1/4	430	9	230	19 1/2	488
34	850	17 7/8	446	9	230	20	502
35	875	18 3/8	460	9	230	20 1/2	514
36	900	19	474	9	230	21	526
37	925	19 1/2	486	9	230	21 1/2	538
38	950	20	502	9	230	22	552
39	975	20 5/8	514	9	230	22 1/2	564
40	1000	21 1/8	528	9	230	23	576
41	1025	21 3/4	542	9	230	23 1/2	588
42	1050	22 1/4	556	9	230	24	602

Visit www.flexco.com for other Flexco locations and products, or to find an authorized distributor.

©2016 Flexible Steel Lacing Company, 08-02-24, X2394

