

MSP Stainless Steel Standard Mine-Duty Precleaner

Effective for Corrosive Environments

The MSP Stainless Steel Standard Mine-Duty Precleaner is not your average solid-blade belt cleaner that mounts on the head pulley. It is a mine-tough design that combines simple, do-it-yourself installation, quick maintenance and effective cleaning results with the added advantage of corrosion resistant stainless steel components.

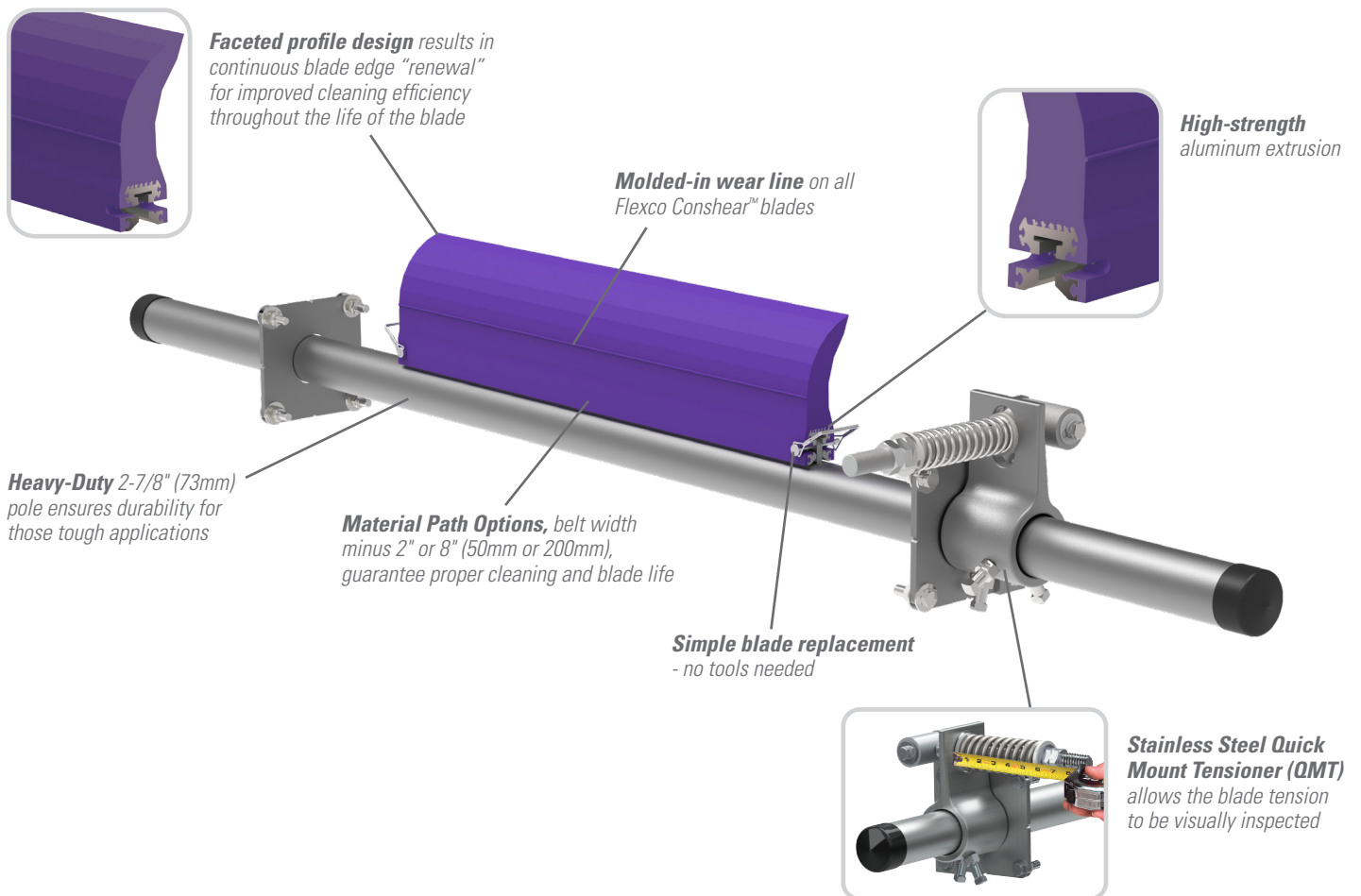

Features and Benefits

- **Stainless steel.** Corrosive environments wear on any component, but stainless steel can protect against that.
- **Quick-change blade.** No tools are needed. Just pull one pin, remove the old blade, slide in the new one and replace the pin.
- **Works with Flexco and other mechanical splices.** The spring tensioner quickly moves the blade away from the belt when a splice passes. The polyurethane blade easily glides over the splice without damage and with minimal cleaning disruption.
- **Easy to service.** All maintenance work is done from the easy-access side of the beltline. Blade retensioning and change-out are quick and easy.
- **Fits most conveyor structures.** Available for belt widths from 12 to 84" (300 to 2100mm). The MSP SS poles are extra long (belt width plus 54" (1350mm)) to accommodate varying structure widths.

MSP Stainless Steel Standard Mine-Duty Precleaner

Specifications and Guidelines

- **Maximum Belt Speed**
700 FPM (3.5 M/sec)
- **Temperature Rating**
-30 to 180°F (-35 to 82°C)
- **Minimum Pulley Diameter**
16" (400mm)
- **Blade Height**
7-1/4" (185mm)
- **Usable Blade Wear Length**
4" (100mm)
- **Blade Material**
Polyurethane 83 durometer
(proprietary blend for abrasion
resistance and long wear)
- **Available for Belt Widths**
24 to 84" (600 to 2100mm)
- **CEMA Cleaner Rating**
Class 3
- **Horizontal Clearance Required**
4" (100mm)
- **Vertical Clearance Required**
10" (254mm)
- **Pole Length**
Cleaner size + 54" (1350mm)
- **Maximum Conveyor Span**
Cleaner size + 44" (1100mm)

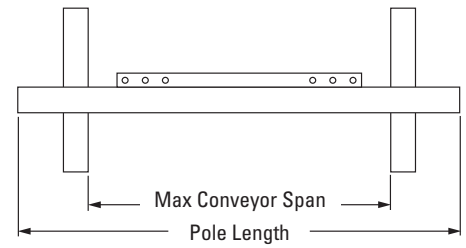
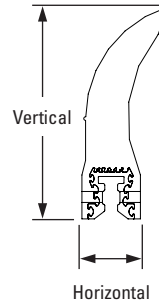

Pole Location Specs

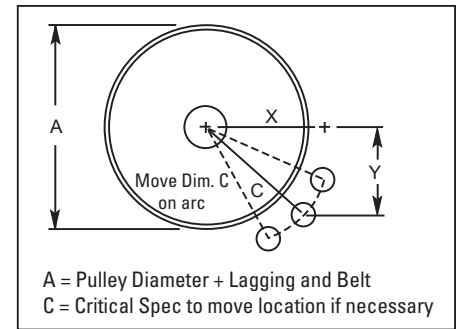

Ordering Information

MSP Stainless Steel Precleaner Belt Width Minus 2" (50mm)					
Belt Width		Blade Width		Ordering Number	Item Code
in.	mm	in.	mm		
24	600	22	550	MSP-224-S/S	77453
30	750	28	700	MSP-230-S/S	77454
36	900	34	850	MSP-236-S/S	77455
42	1050	40	1000	MSP-242-S/S	77456
48	1200	46	1150	MSP-248-S/S	77457
54	1350	52	1300	MSP-254-S/S	77458
60	1500	58	1450	MSP-260-S/S	77459
72	1800	70	1750	MSP-272-S/S	77460
84	2100	82	2050	MSP-284-S/S	77461
Belt Width Minus 8" (200mm)					
24	600	16	400	MSP-824-S/S	77462
30	750	22	550	MSP-830-S/S	77463
36	900	28	700	MSP-836-S/S	77464
42	1050	34	850	MSP-842-S/S	77465
48	1200	40	1000	MSP-848-S/S	77466
54	1350	46	1150	MSP-854-S/S	77467
60	1500	52	1300	MSP-860-S/S	77468
72	1800	64	1600	MSP-872-S/S	77470
84	2100	76	1900	MSP-884-S/S	77471

Lead time: 3 weeks

Replacement ConShear™ Blades			
Blade Width		Ordering Number	Item Code
in.	mm		
10	250	CRB-10	75628
16	300	CRB-16	75629
22	350	CRB-22	75630
28	450	CRB-28	75631
34	600	CRB-34	75632
40	750	CRB-40	75633
46	800	CRB-46	75634
52	950	CRB-52	75635
58	1000	CRB-58	75636
64	1150	CRB-64	75775
70	1200	CRB-70	75773
76	1350	CRB-76	76940
82	1400	CRB-84	76941

Other blade sizes available upon request.
Lead time: 1 working day

Pole Location Chart

A		X		Y		C	
in.	mm	in.	mm	in.	mm	in.	mm
10	250	2 5/8	68	9	230	9 4/8	240
11	275	3 4/8	88	9	230	9 6/8	246
12	300	4	102	9	230	9 7/8	252
13	325	5 1/8	130	9	230	10 3/8	264
14	350	5 5/8	142	9	230	10 5/8	270
15	375	6 4/8	164	9	230	11 1/8	282
16	400	7 1/8	176	9	230	11 1/2	290
17	425	7 7/8	196	9	230	12	302
18	450	8 1/4	204	9	230	12 1/4	308
19	475	9	222	9	230	12 3/4	320
20	500	9 3/8	232	9	230	13	326
21	525	10	248	9	230	13 1/2	338
22	550	10 3/4	266	9	230	14	352
23	575	11 3/8	282	9	230	14 1/2	364
24	600	12	298	9	230	15	376
25	625	12 5/8	312	9	230	15 1/2	388
26	650	13 1/4	330	9	230	16	402
27	675	13 7/8	344	9	230	16 1/2	414
28	700	14 3/8	358	9	230	17	426
29	725	15	372	9	230	17 1/2	438
30	750	15 5/8	390	9	230	18	452
31	775	16 1/8	402	9	230	18 1/2	464
32	800	16 3/4	416	9	230	19	476
33	825	17 1/4	430	9	230	19 1/2	488
34	850	17 7/8	446	9	230	20	502
35	875	18 3/8	460	9	230	20 1/2	514
36	900	19	474	9	230	21	526
37	925	19 1/2	486	9	230	21 1/2	538
38	950	20	502	9	230	22	552
39	975	20 5/8	514	9	230	22 1/2	564
40	1000	21 1/8	528	9	230	23	576
41	1025	21 3/4	542	9	230	23 1/2	588
42	1050	22 1/4	556	9	230	24	602

Visit www.flexco.com for other Flexco locations and products, or to find an authorized distributor.

©2014 Flexible Steel Lacing Company, 08-05-24, X2362

