

MSP Stainless Standard-Duty Precleaner

Effective for Corrosive Environments

The MSP Stainless Steel Standard-Duty Precleaner is not your average solid-blade belt cleaner that mounts on the head pulley. It is a mine-tough design that combines simple, do-it-yourself installation, quick maintenance and effective cleaning results with the added advantage of corrosion resistant stainless steel components.

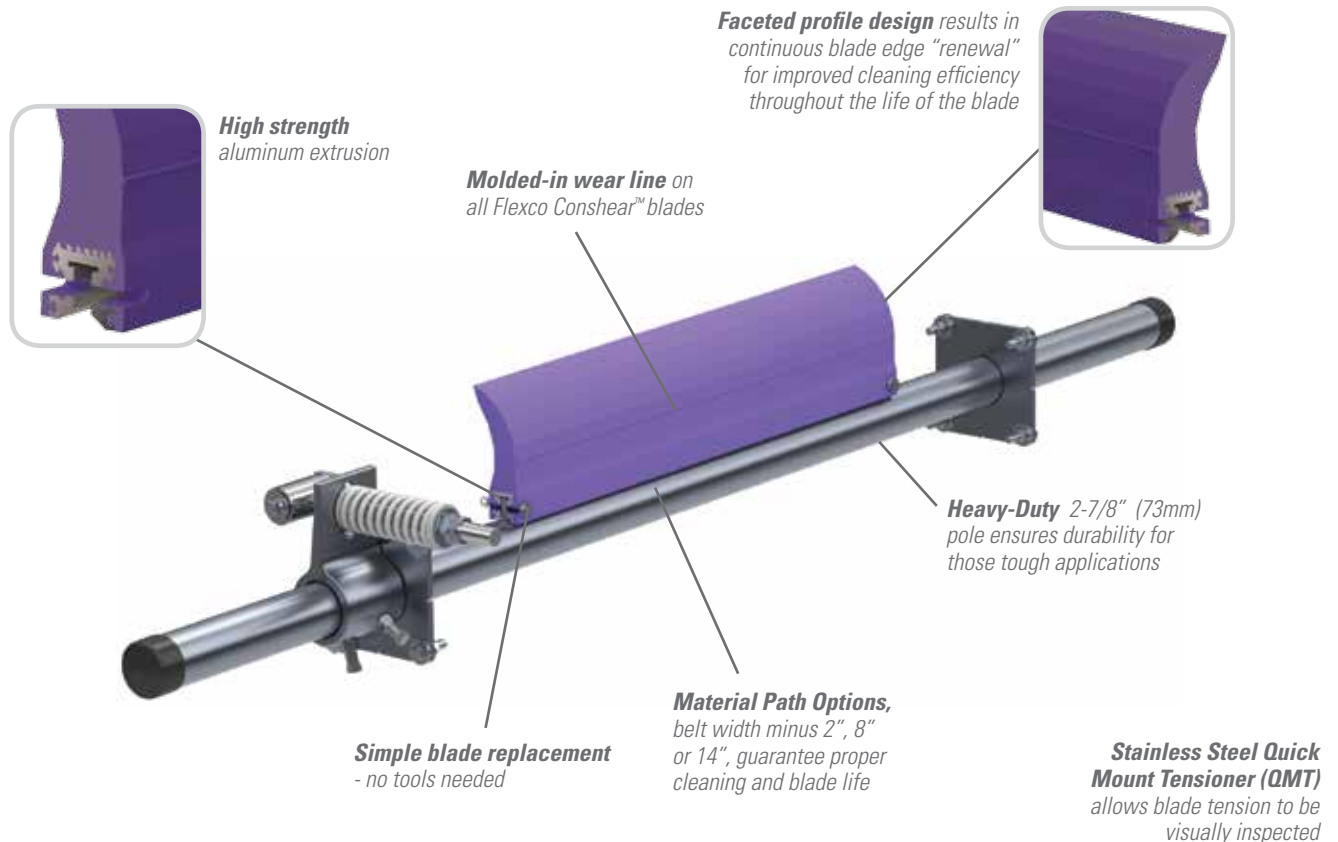

Features and Benefits

- **Stainless steel.** Corrosive environments wear on any component, but stainless steel can protect against that.
- **Quick-change blade.** No tools are needed. Just pull one pin, remove the old blade, slide in the new one and replace the pin.
- **Works with Flexco and other mechanical splices.** The spring tensioner quickly moves the blade away from the belt when a splice passes. The polyurethane blade easily glides over the splice without damage and with minimal cleaning disruption.
- **Easy to service.** All maintenance work is done from the easy-access side of the beltline. Blade retensioning and change-out are quick and easy.
- **Fits most conveyor structures.** Available for belt widths from 12" to 84" (300-2100 mm). The MSP SS poles are extra long (belt width plus 54"/1350mm) to accommodate varying structure widths.



MSP Stainless

Standard-Duty Precleaner

Specifications and Guidelines

- **Maximum Belt Speed**
700 FPM (3.5 M/sec)
- **Temperature Rating**
-30°F to 180°F (-35°C to 82°C)
- **Minimum Pulley Diameter**
16" (400mm)
- **Blade Height**
7-1/4" (185mm)
- **Usable Blade Wear Length**
4" (100mm)
- **Blade Material**
Urethane 83 durometer (proprietary blend for abrasion resistance and long wear)
- **Available for Belt Widths**
24" to 84" (600 to 2100mm)
- **Horizontal Clearance Required**
4" (100mm)
- **Vertical Clearance Required**
10" (254mm)
- **CEMA Cleaner Rating**
Class 3
- **Pole Length**
Cleaner size + 54" (1350mm)
- **Maximum Conveyor Span**
Cleaner size + 44" (1100mm)

Pole Location Specs

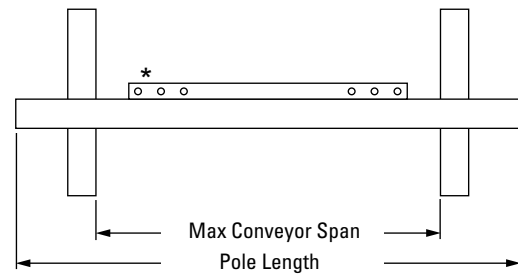
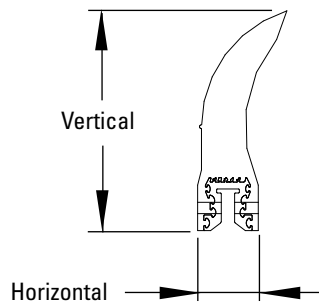
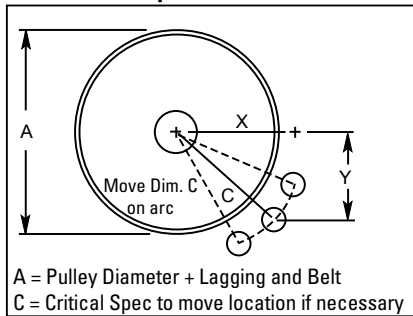

Pole Location Chart

A	X	Y	C	A	X	Y	C	A	X	Y	C
16"	7-1/8"	9"	11-1/2"	25"	12-5/8"	9"	15-1/2"	34"	17-7/8"	9"	20"
17"	7-7/8"	9"	12"	26"	13-1/4"	9"	16"	35"	18-3/8"	9"	20-1/2"
18"	8-1/4"	9"	12-1/4"	27"	13-7/8"	9"	16-1/2"	36"	19"	9"	21"
19"	9"	9"	12-3/4"	28"	14-3/8"	9"	17"	37"	19-1/2"	9"	21-1/2"
20"	9-3/8"	9"	13"	29"	15"	9"	17-1/2"	38"	20"	9"	22"
21"	10"	9"	13-1/2"	30"	15-5/8"	9"	18"	39"	20-5/8"	9"	22-1/2"
22"	10-3/4"	9"	14"	31"	16-1/8"	9"	18-1/2"	40"	21-1/8"	9"	23"
23"	11-3/8"	9"	14-1/2"	32"	16-3/4"	9"	19"	41"	21-3/4"	9"	23-1/2"
24"	12"	9"	15"	33"	17-1/4"	9"	19-1/2"	42"	22-1/4"	9"	24"

Ordering Information

MSP SS Precleaners - Belt Width Minus 2"					
Belt Width		Blade Coverage		Ordering Number	Item Code
in.	mm	in.	mm		
24	600	22	550	MSP-224-S/S	77453
30	750	28	700	MSP-230-S/S	77454
36	900	34	850	MSP-236-S/S	77455
42	1050	40	1000	MSP-242-S/S	77456
48	1200	46	1150	MSP-248-S/S	77457
54	1350	52	1300	MSP-254-S/S	77458
60	1500	58	1450	MSP-260-S/S	77459
72	1800	70	1750	MSP-272-S/S	77460
84	2100	82	2050	MSP-284-S/S	77461

MSP SS Precleaners - Belt Width Minus 3"					
Belt Width		Blade Coverage		Ordering Number	Item Code
in.	mm	in.	mm		
24	600	16	400	MSP-824-S/S	77462
30	750	22	550	MSP-830-S/S	77463
36	900	28	700	MSP-836-S/S	77464
42	1050	34	850	MSP-842-S/S	77465
48	1200	40	1000	MSP-848-S/S	77466
54	1350	46	1150	MSP-854-S/S	77467
60	1500	52	1300	MSP-860-S/S	77468
72	1800	64	1600	MSP-872-S/S	77470
84	2100	76	1900	MSP-884-S/S	77471

ConShear™ Replacement Blades				
Blade Width		Ordering Number	Item Code	
in.	mm			
16	400	CRB16	75629	
22	550	CRB22	75630	
28	700	CRB28	75631	
34	850	CRB34	75632	
40	1000	CRB40	75633	
46	1150	CRB46	75634	
52	1300	CRB52	75635	
58	1450	CRB58	75636	
64	1600	CRB64	75775	
70	1750	CRB70	75773	
76	1900	CRB76	76940	
82	2050	CRB82	76941	

Lead time: 1 working day

Shaded items are made to order.
Lead time: 3 weeks

Authorized Distributor:



2525 Wisconsin Avenue • Downers Grove, IL 60515-4200 • USA
Tel: (630) 971-0150 • Fax: (630) 971-1180 • E-mail: info@flexco.com

Visit www.flexco.com for other Flexco locations and products.

©2014 Flexible Steel Lacing Company. 09/14. For Reorder: X2362

