

Electric Belt Cutter

Replacement Drill Instructions

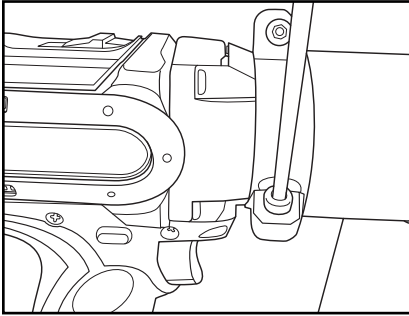

1. Unplug drill from power source. Disassemble drill from housing by removing three screws (4 mm hex key).

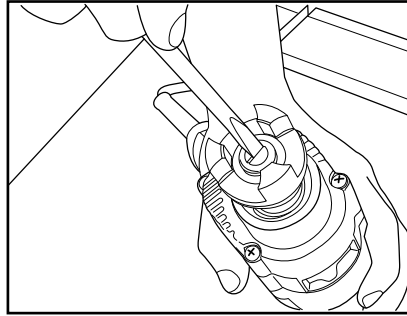

2. Remove left-handed screw that attaches the coupling to the housing by turning it in a clockwise direction.

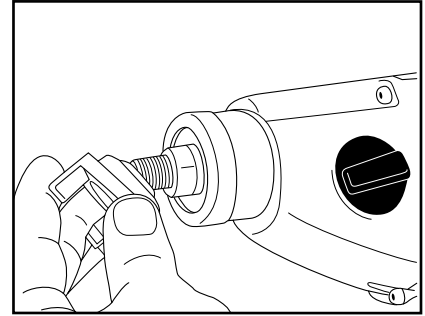

3. Disassemble female coupling from old drill by unscrewing from the drill shaft.

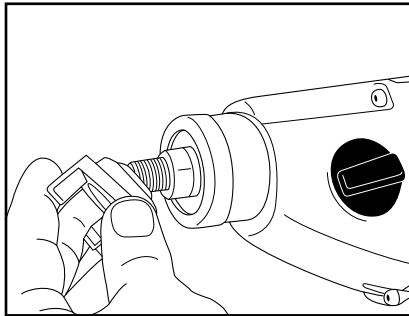

4. Screw female coupling onto new drill shaft.

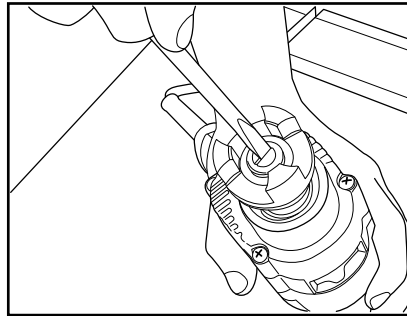

5. Secure coupling to drill by applying Loctite®, inserting left-handed screw, and tightening it in a counter-clockwise direction.

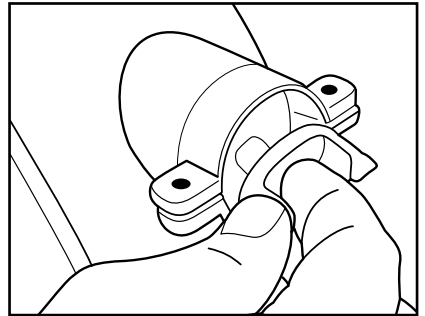

6. Make sure coupling and black rubber "spider" (part of original unit) are placed in the housing and that the key and keyway are engaged.

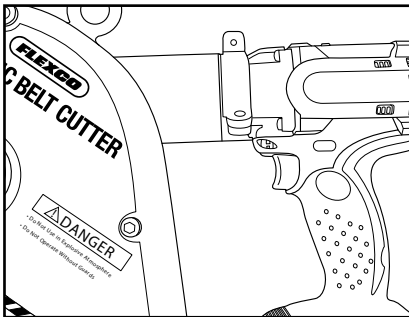

7. Insert drill into housing, be sure to align the couplings. For proper coupling engagement, there should be no space between the housing neck and drill casing. Verify that the drill is working and the blade is rotating before installing the final screws.

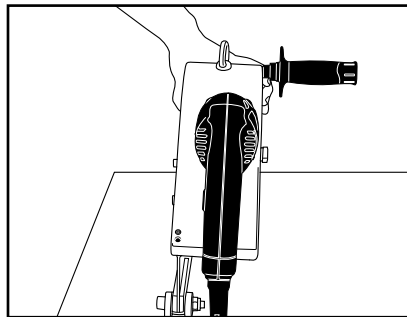

8. Align drill vertically with the housing.

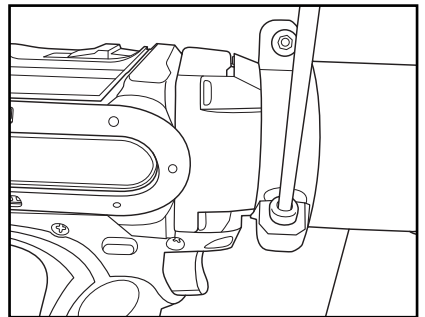

9. Lock the drill in place by applying Loctite to the three screws and installing until tight.



2525 Wisconsin Avenue • Downers Grove, IL 60515-4200 • USA
Tel: (630) 971-0150 • Fax: (630) 971-1180 • E-mail: info@flexco.com

Visit www.flexco.com for other Flexco locations and products.

©2009 Flexible Steel Lacing Company. 04-23-20. For Reorder: X2145

