



Alligator® Staple Gold Class™

Instructions for Installation and Tool Maintenance

Maintenance:

- Do not remove regulator whip assembly.
- Do not exceed 120 PSI incoming air pressure.
- Do not depress tool trigger before the belt and fasteners are loaded in place and tool is completely down on top of guide block, as this will damage the tool.
- Oil air line with one to two drops prior to use.
- Every year: Inspect o-rings, cylinder and piston for wear or damage and replace worn components. Add air tool oil to inside cavity of tool, lubricate pistons and cylinder with silicon grease.

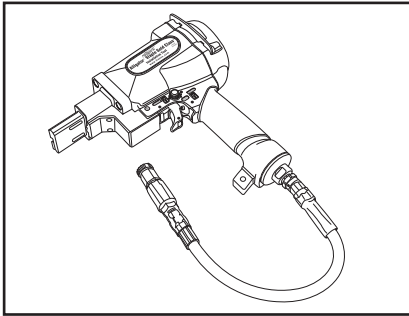

1. Do not remove regulatory whip assembly. Connect the Alligator® Staple Gold Class™ staple driver to a clean, dry air line with a maximum incoming pressure of 120 PSI. The driver regulator will bring air source down to 70 PSI.

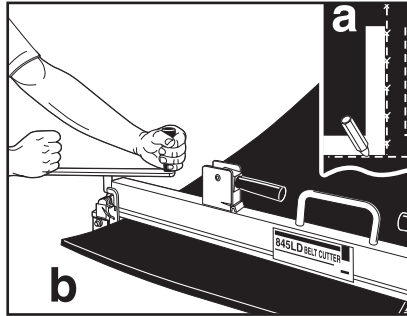

2. (a) Square belt using centerline method. (b) Cut belt using the Clipper® 845LD Belt Cutter.

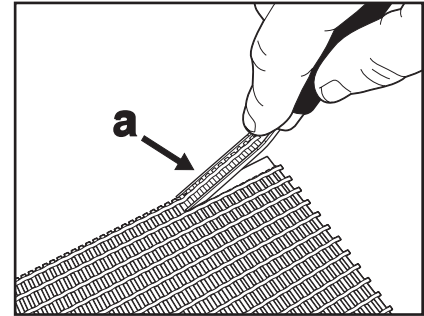

3. (a) Skive rough-top belt using Flexco skiving products. Select correct fastener size.

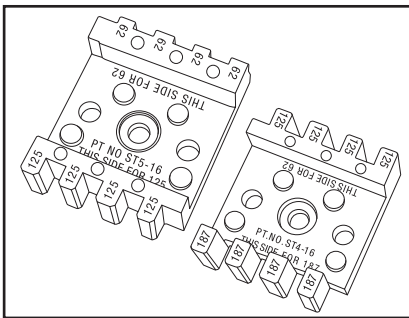

4. Ensure applicator combs are in good condition and correspond to the fastener size being installed.

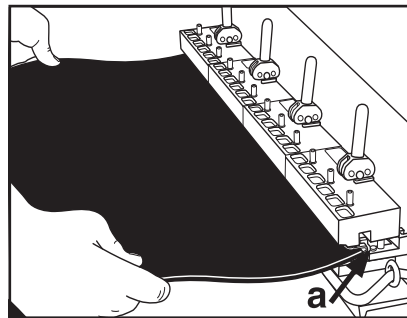

5. Center fastener strip in the Initial Drive installation tool. Fastener Strip should be tight against tool. (a) Cam lever(s) should be up. Center belt in installation tool, equal distance between belt ends.

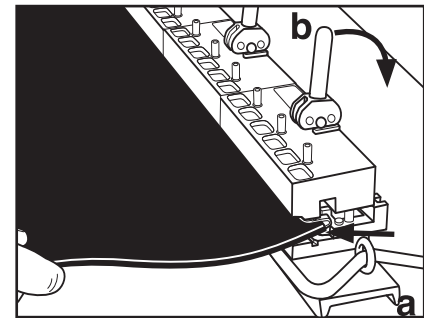

6. (a) Belt end should be tight against the fastener belt stops. (b) Depress cam lever(s). Fastener top should lean forward. If not, tighten handle clockwise to increase pressure.

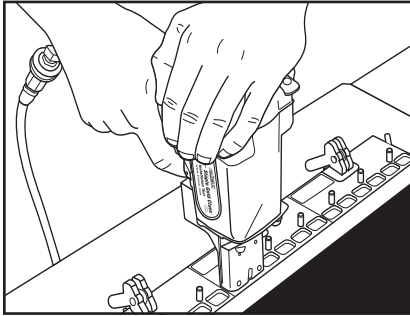

7. Starting with the center fastener plates, insert the nose of the Alligator Staple Gold Class driver into the guide block. Note: the driver must be firmly seated into the pin to activate safety switch. Apply adequate number of trigger pulls to produce sufficient staple leg fold. Refer to chart below. Drive belt ends next. Do not overdrive staples.

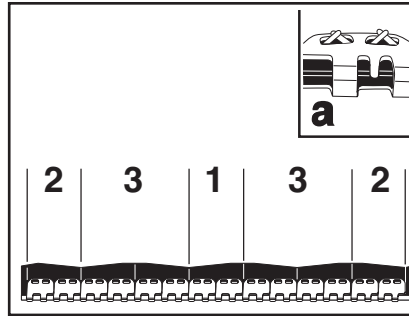

8. Follow the sequence shown above to drive all remaining fasteners. (a) Staples will be partially clinched.

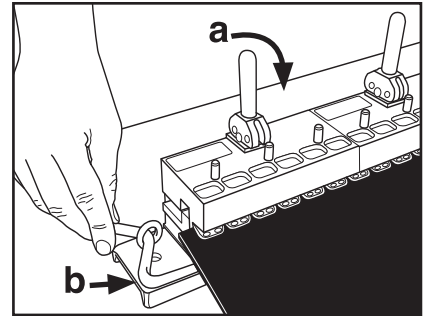

9. (a) Raise cam levers, (b) pop up belt using release bar.

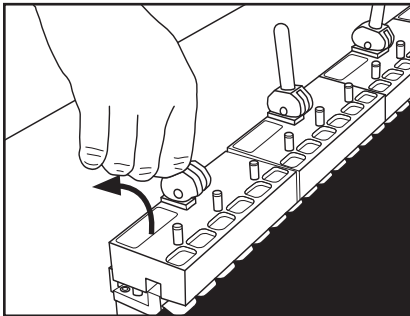

10. Center belt in Final Set installation tool depress cam levers. Insert the nose of the Alligator Staple Gold Class driver into the guide block. Note: the driver must be firmly seated into the pin to activate safety switch. Apply adequate number of trigger pulls to provide desired final set. Refer to chart below. Remove belt from tool.

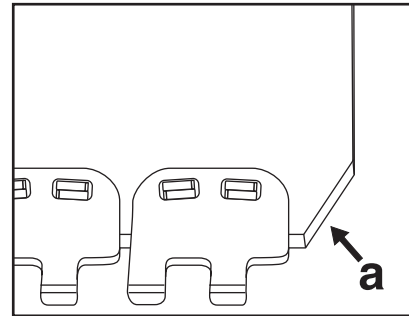

11. Using Belt Nippers, (a) notch trailing edge of belt only. Notch at an angle.

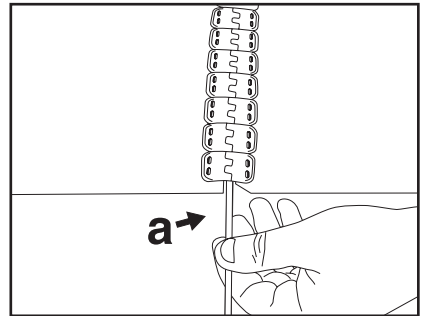

12. Bring belt ends together and (a) insert hinge pin. If retaining washer is used, crimp with pliers. Splice is complete

AVERAGE TRIGGER PULLS

Fastener Size	Average Trigger Pulls for:	
	Initial Drive	Final Set
RS62	1-2	1-2
RS125	2-3	2-3
RS187	3-4	3-4

Note: Number of trigger pulls will vary depending on belt thickness and durometer.