

The Economical, Efficient Belt Training Solution

The patented PT Smart™ Belt Trainer takes our unique "pivot and tilt" design and puts it into a more economical, medium-duty trainer. This unit reacts and compensates instantly to belt misalignment, ensuring that the belt stays away from the structure and the material stays on the belt. The result: a continuous solution to mistracking problems that cause damage to the belt and conveyor structure-at an affordable price.

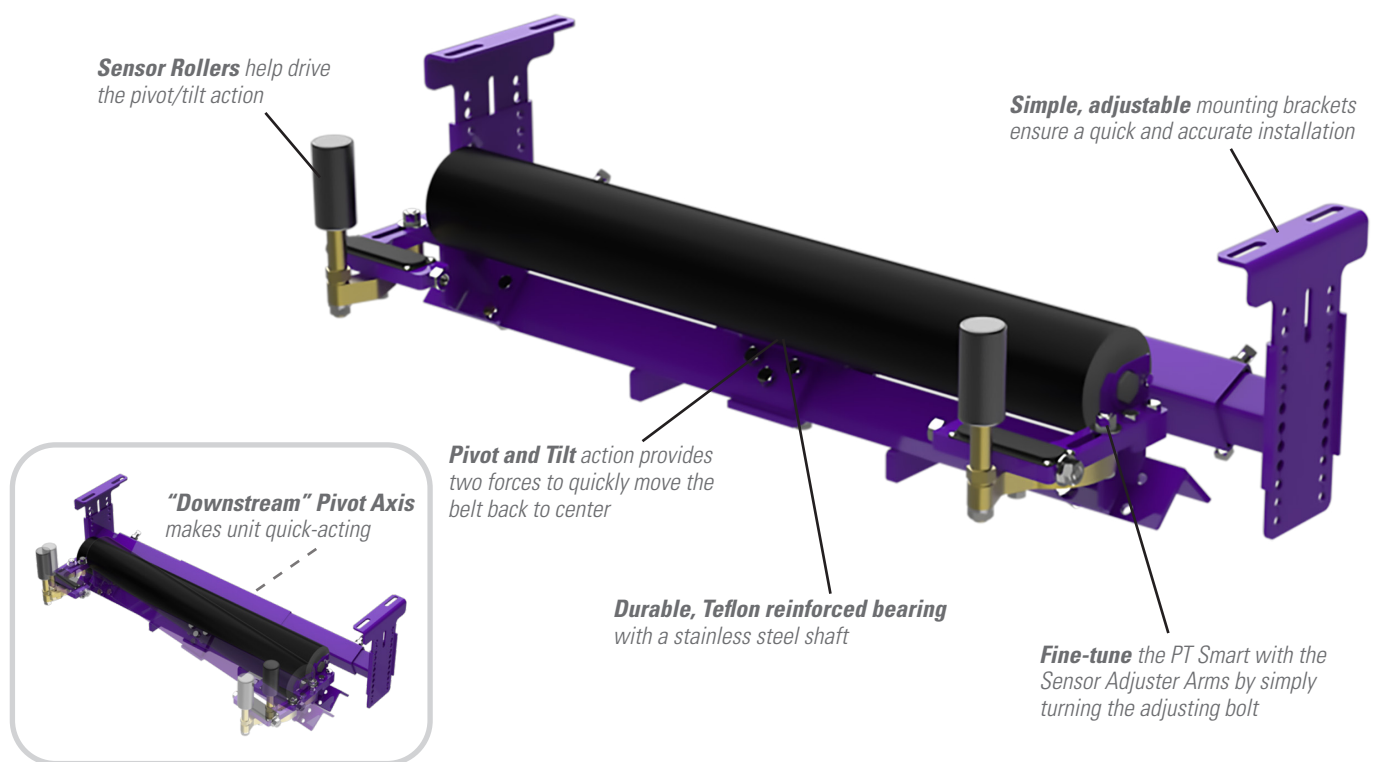

Features and Benefits

- **Works in multiple applications.** Above-ground version features an idler belt width + 3" (75mm), 2" (50mm) sensor rollers, and easy-to-install mounting brackets. Underground version comes with an idler belt width + 9" (225mm), 3" (75mm) sensor rollers, and an extended mounting bracket for underground structures.
- **Easy ordering and installation.** Enhanced to meet instant demands for training solutions, the PT Smart™ is available on a one-working-day lead time. The simple brackets and component construction also ensures a quick and easy installation.
- **Economical.** PT Smart™ is a very versatile, budget-conscious, out-of-the-box solution.
- **Made to last.** Durable and strong, the PT Smart™ offers a 2-year "No Risk" Performance Guarantee.
- **Works with mechanically fastened or vulcanized belts.**

Specifications and Guidelines

- **Maximum Belt Speed**
1000 FPM (5 m/s)
- **Temperature Rating**
-40 to 180°F (-40 to 82°C)
- **Belt Direction**
One Way
- **Available for Belt Widths**
18 to 72" (450 to 1800mm)

Selection Guidelines	
MODEL	APPLICATION RANGE
PT Smart™	Medium-duty belts up to 1600 PIW (280 n/mm) max tension. Belt width + 3" (75mm) idler. Belt thickness 1" (25mm) maximum.
PT Smart™ Underground	Medium-duty belts up to 1600 PIW (280 n/mm) max tension. Belt width + 9" (225mm) idler. Belt thickness 1" (25mm) maximum. Fits underground structure.

Selection Guidelines		
CONVEYOR CRITERIA	PT SMART™	PT SMART™ UNDERGROUND
Top side mistracking	NO	NO
Return side mistracking	YES	YES
Belt mistracking to one side	EXCELLENT	EXCELLENT
Belt mistracking to both sides	EXCELLENT	EXCELLENT
Inconsistent tracking problem	EXCELLENT	EXCELLENT
Belt is cupped (heavy)	GOOD	GOOD
Belt has low running tension	EXCELLENT	EXCELLENT
Belt has medium running tension	EXCELLENT	EXCELLENT
Belt has high running tension	GOOD	GOOD
Approx. "upstream" effect*	20' (6 M)	20' (6 M)
Approx. "downstream" effect*	120–150' (36–45 M)	120–150' (36–45 M)

Ordering Information

PT Smart™ Belt Trainer				Replacement Rollers	
Belt Width		Ordering Number	Item Code	Ordering Number	Item Code
in.	mm				
18	450	PTS-18R	77664	PTS-RR21	77680
24	600	PTS-24R	77665	PTS-RR27	77681
30	750	PTS-30R	77666	PTS-RR33	77682
36	900	PTS-36R	77667	PTS-RR39	77683
42	1050	PTS-42R	77668	PTS-RR45	77684
48	1200	PTS-48R	77669	PTS-RR51	77685
54	1350	PTS-54R	77670	PTS-RR57	77686
60	1500	PTS-60R	77671	PTS-RR63	77687
72	1800	PTS-72R	77672	PTS-RR75	77689
PT Smart™ Underground Belt Trainer				Replacement Rollers	
Belt Width		Ordering Number	Item Code	Ordering Number	Item Code
in.	mm				
30	750	PTS-30R-UG	77673	PTS-RR39	77683
36	900	PTS-36R-UG	77674	PTS-RR45	77684
42	1050	PTS-42R-UG	77675	PTS-RR51	77685
48	1200	PTS-48R-UG	77676	PTS-RR57	77686
54	1350	PTS-54R-UG	77677	PTS-RR63	77687
60	1500	PTS-60R-UG	77678	PTS-RR69	77688
72	1800	PTS-72R-UG	77679	PTS-RR81	77690

Lead time: 1 working day