

DRX200, DRX750 and DRX1500 Models

Installation, Operation and Maintenance Manual



DRX™ Impact Beds

Serial Number:	_____
Purchase Date:	_____
Purchased From:	_____
Installation Date:	_____

Serial number information can be found on the Serial Number Label included in the Information Packet shipped with the impact bed.

This information will be helpful for any future inquiries or questions about replacement parts, specifications or troubleshooting.

Table of Contents

Section 1 - Important Information	4
1.1 General Introduction.....	4
1.2 User Benefits	4
1.3 Proper Impact Bed Selection	5
1.4 Selecting the Right Impact Bar.....	5
1.5 Installation and Service Option.....	5
1.6 DRX™ Impact Bed Spec Sheet.....	7
Section 2 - Safety Considerations and Precautions	8
2.1 Stationary Conveyors.....	8
2.2 Operating Conveyors.....	8
Section 3 - Pre-Installation Checks and Options.....	9
3.1 Checklist.....	9
3.2 Optional Installation Accessories.....	10
Section 4 - Installation Instructions.....	11-14
Section 5 - Pre-Operation Checklist and Testing.....	15
5.1 Pre-Op Checklist.....	15
5.2 Test Run the Conveyor	15
Section 6 - Maintenance.....	16
6.1 New Installation Inspection.....	16
6.2 Routine Visual Inspection.....	16
6.3 Routine Physical Inspection	16
6.4 Impact Bar Replacement Instructions.....	17
6.5 Maintenance Log.....	19
6.6 Impact Bed Maintenance Checklist.....	20
Section 7 - Troubleshooting	21
Section 8 - Specs and CAD Drawings.....	22
8.1 Specifications and Guidelines.....	22
8.2 CAD Drawings	23
Section 9 - Replacement Parts	26
9.1 Replacement Parts List	26-28
9.2 Optional Replacement Parts	29
Section 10 - Other Flexco Conveyor Products.....	31

Section 1 - Important Information

1.1 General Introduction

We at Flexco are very pleased that you have selected a DRX™ Impact Bed for your conveyor system.

This manual will help you to understand the operation of this product and assist you in making it work up to its maximum efficiency over its lifetime of service.

It is essential for safe and efficient operation that the information and guidelines presented be properly understood and implemented. This manual will provide safety precautions, installation instructions, maintenance procedures and troubleshooting tips.

If, however, you have any questions or problems that are not covered, please visit our web site or contact our Customer Service Department:

Customer Service: 1-800-541-8028

Visit www.flexco.com for other Flexco locations and products.

Please read this manual thoroughly and pass it on to any others who will be directly responsible for installation, operation and maintenance of this cleaner. While we have tried to make the installation and service tasks as easy and simple as possible, **it does however require correct installation and regular inspections and adjustments to maintain top working condition.**

1.2 User Benefits

The “transfer point” is integrally important to the successful operation of a belt conveyor system. The material transferred from one conveyor (or other source) to another conveyor must be done without damaging the conveyor’s key component...the belt. A correctly-selected impact bed is critical for this task.

Since material size, weight and the drop height can cause considerable impact force that can damage the belt, the right impact bed must be chosen to absorb the impact energy and minimize any damage to the beltline.

The proper impact bed can also support the belt in the loading zone to prevent material spillage.

The DRX Impact Beds offer these features and benefits:

- Extra Belt Protection - DRX means “Dual Relief Xtra”. Our beds offer our exclusive Velocity Reduction Technology™, which means two levels of force reduction to absorb more impact energy and minimize transmission back to the belt. The impact bars are properly supported for one level of defense and unique Impact Energy Absorbers provide the second level of impact relief. The results: less belt damage and less rebounding and degradation of the materials.

Section 1 - Important Information

- **Easy Maintenance** - Our Slide-Out Service™ is quick, safe and convenient. Each bed separates in the middle and the two sides slide apart. This provides easy access to all of the impact bars for replacement.
- **Cost Effective** - Each bed is constructed with steel channel crossbeams for long service life; and low-cost square washers and carriage bolts replace traditional, expensive T-bolts for securing the impact bars.

1.3 Proper Impact Bed Selection

DRX™ impact beds are expressly designed to absorb energy from falling materials. The bed model should be spec'd to the needs of the conveyor application. To do this, the following data points are needed (Also see the DRX Impact Bed Spec Sheet on Page 7).

1. **Belt Width** - This is typically a simple check and the only additional information that would be required is if belt width is inconsistent with structure width.
2. **Troughing Angle** - What is the angle of the current bed or troughing set?
3. **Roller Diameter and CEMA Rating** - Rollers are typically 5" or 6" (125 or 150mm) and rated CEMA C, D or E.
4. **Bed Length** - Typically 4' or 5' (1.2M or 1.5M). Special lengths available upon request.

Material	lb/ft³
Coke	41
Fertilizer	60
Bauxite, crushed	80
Potash	80
Coal, Bituminous, Solid	84
Coal, Anthracite, Solid	94
Slag, Solid	132
Chromium Ore	135
Halite (Salt), Solid	145
Phosphorus	146
Stone (Common, Generic)	157
Limestone, Solid	163
Shale, Solid	167
Granite, Solid	168
Gypsum, Solid	174
Trap Rock, Solid	180
Dolomite, Solid	181
Malachite (Copper Ore)	241
Platinum Ore	268
Hematite (Iron Ore)	322

5. **Drop Height and Lump Size & Weight** - This is the critical information required.
 - a. **Drop Height** - The measurement from where the material leaves the feeding conveyor to where it makes contact with the receiving conveyor.
 - b. **Lump Size and Weight** - The lump size - The largest dimension of the material pieces dropping. The material weight is of the largest lump size found and weighed.
 - c. **Chart for Rough Calculations** - Weighing is always more accurate, but the chart values will give a rough weight estimate.

NOTE: Shale is approximately the same as limestone.

Section 1 - Important Information

Now you can calculate the impact energy (in lb.-ft.) and make the bed selection by the rating chart.

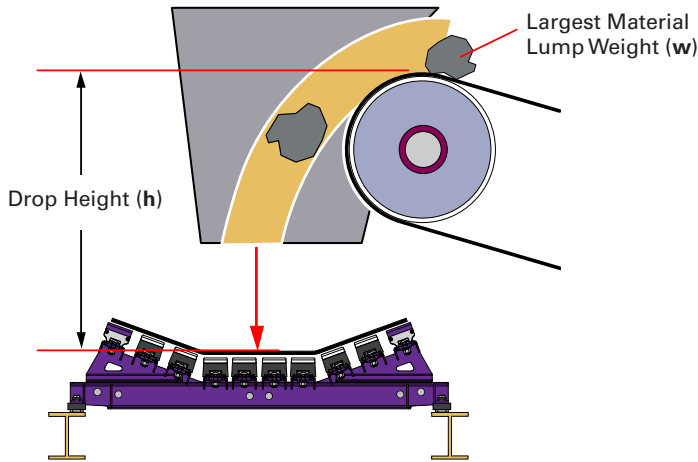

A sample DRX™ Impact Bed Spec Sheet is included (Page 7) for future use.

By using this simple lb-ft formula, for whatever your application, you will know the load capacities needed to specify the best DRX™ Impact Bed to get the job done right.

Calculate Impact Energy:

$$\begin{array}{r} \text{Lump weight} \quad \underline{\hspace{2cm}} \quad \text{lb} \\ \times \text{Drop length} \quad \underline{\hspace{2cm}} \quad \text{ft} \\ \hline \text{Total} \quad \underline{\hspace{2cm}} \quad \text{lb-ft} \end{array}$$

Match lb-ft to bed rating:

Up to 200 lb-ft (25 kg-m)	DRX 200
200 to 750 lb-ft (25 to 100 kg-m)	DRX 750
750 to 1500 lb-ft (100 to 200 kg-m)	DRX 1500
1500 to 3000 lb-ft (200 to 400 kg-m)	DRX 3000

1.4 Selecting the Right Impact Bar

The primary purpose of the impact bars is to absorb the energy of the falling material and prevent damage to the belt. They are the first line of defense. Typical impact bars can be purchased with a 1/2" (13mm) UHMW top cover or with a longer-wearing 1" (25mm) top cover. Care should be taken to choose the right top cover thickness for your application to ensure maximum energy absorption.

Generally, impact bars are 3" (75mm) high and 4" (100mm) wide. They are made up of an aluminum extrusion base, an elastomer (rubber) center, and a low-friction (UHMW) top cover. The extrusion takes up about 1" (25mm) of the bar's height. That means that depending on the thickness of the top cover chosen (1/2" or 1"; 13mm or 25mm), the energy-absorbing rubber core is either 1-1/2" (38mm) or 1" (25mm). Reducing the rubber core of each bar by 50% in heavier impact applications can reduce the impact bed's effectiveness and performance.

Some general guidelines:

1. The impact bed's primary use is for dust suppression with no sizable amount of impact (for loads not exceeding 1500 lb-ft of impact energy), choose the 1" (25mm) top cover. It will offer twice the service life with no measurable performance degradation.
2. For applications with 1500 lb-ft or more of impact force, the 1/2" (13mm) -topcover is strongly recommended. It will provide 50% more energy impact protection for the belt.

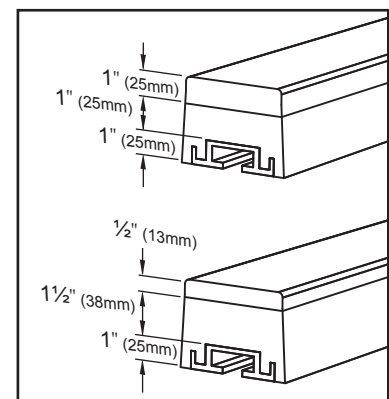

1.5 Installation and Service Option

The DRX Impact Bed is designed to be easily installed and serviced by your on-site personnel. However, if you would prefer complete turn-key factory service, please contact your local Flexco® Field Engineer or your Flexco Distributor.

1.6 DRX Impact Bed Spec Sheet

CUSTOMER INFO:

Company Name: _____
 Address: _____ Date: _____
 _____ Phone #: _____
 Contact Name: _____ Fax #: _____
 Title/Position: _____ e-Mail: _____

_____	A	Mounting Bolt Center-to-Center	_____	Idler Length 1
_____	B	Center Roll Height Above Mounting Base	_____	Idler Length 2
_____	C	Inside Structure Dimension	_____	Idler Length 3
_____	D	Trough Angle		
_____	E	Belt Width		
_____	F	Length of Load Zone		
_____	G	Material		
_____	H	Drop Height		
_____	I	Maximum Lump Size		
Length	Width	Height		
_____	J	Tons per Hour		
_____	K	Belt Speed		
_____	W	Maximum Lump Weight		

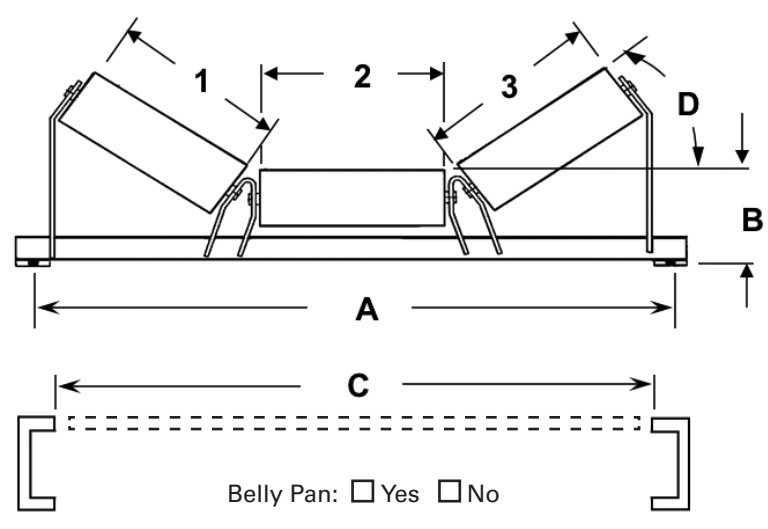

Impact Energy Calculation Chart

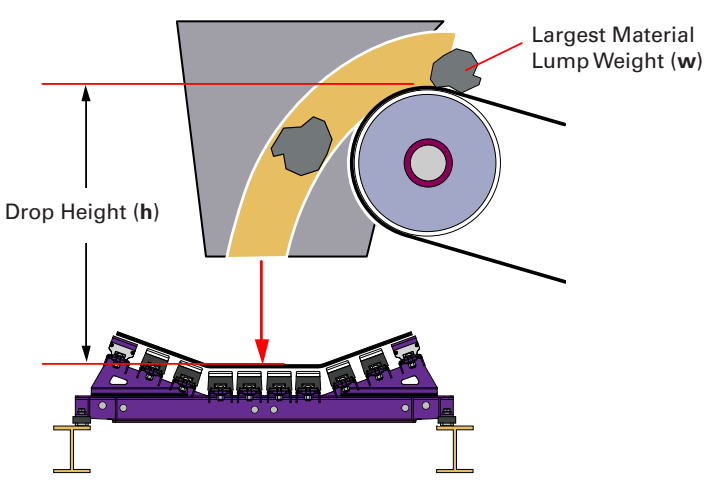

Impact Energy

Lump Weight (**w**) _____
 Drop Height (**h**) x _____
 Total - **lb-ft (kg-m)** _____

See below for bed recommendation/selection

Bed Selection:

- Up to 200 lb-ft (25 kg-m) DRX 200
- 200 to 750 lb-ft (25 to 100 kg-m) DRX 750
- 750 to 1500 lb-ft (100 to 200 kg-m) DRX 1500
- 1500 to 3000 lb-ft (200 to 400 kg-m) DRX 3000



Section 2 - Safety Considerations and Precautions

Before installing and operating the DRX™ Impact Bed, it is important to review and understand the following safety information.

There are set-up, maintenance and operational activities involving both **stationary** and **operating** conveyors. Each case has a safety protocol.

2.1 Stationary Conveyors

The following activities are performed on stationary conveyors:

- Installation
- Skirt rubber adjustments
- Impact bar replacement
- Cleaning
- Repairs

DANGER

It is imperative that OSHA/MSHA Lockout/Tagout (LOTO) regulations, 29 CFR 1910.147, be followed before undertaking the preceding activities. Failure to use LOTO exposes workers to uncontrolled behavior of the impact bed caused by movement of the conveyor belt. Severe injury or death can result.

Before working:

- Lockout/Tagout the conveyor power source
- Disengage any takeups
- Clear the conveyor belt or clamp securely in place

WARNING

Use Personal Protective Equipment (PPE):

- Safety eyewear
- Hardhats
- Safety footwear

Close quarters and heavy components create a worksite that compromises a worker's eyes, feet and skull. PPE must be worn to control the foreseeable hazards associated with conveyor belt components. Serious injuries can be avoided.

2.2 Operating Conveyors

There are two routine tasks that must be performed while the conveyor is running:

- Inspection of the sealing performance
- Dynamic troubleshooting

DANGER

Every belt conveyor is an in-running nip hazard. Never touch or prod an operating impact bed. Conveyor hazards cause instantaneous amputation and entrapment.

WARNING

Never adjust anything on an operating impact bed. Unforseeable materials falling into the chute can cause violent movements of the impact bed structure. Flailing hardware can cause serious injury or death.

WARNING

Conveyor chutes contain projectile hazards. Stay as far from the impact bed as practical and use safety eyewear and headgear. Missiles can inflict serious injury.

Section 3 - Pre-Installation Checks and Options

3.1 Checklist

- Check the model and size of the impact bed. Is it the right one for your beltline?
- Check the bed to be sure all the parts are included in the shipment.
- Find the Information Packet in the shipment.
- Review the “Tools Needed” section on the front of the installation instructions.
- Prepare the conveyor site:
 - Lift the belt in the transfer zone. Use a lifting hoist or Flexco’s Belt Lifters.
 - Remove the old impact bed or impact idlers.
 - Inspect the conveyor structure for damage or misalignment. Make adjustments as necessary.
 - Troughing idlers should be installed directly before and after the new impact bed.

Section 3 - Pre-Installation Checks and Options

3.2 Optional Installation Accessories

Optional tools can make the installation of the DRX™ Impact Bed easier and faster.

Flex-Lifter Conveyor Belt Lifter

Description	Ordering Number	Item Code
Medium Flex-Lifter 36" - 60" (900 - 1500 mm)	FL-M	76469
Large Flex-Lifter 48" - 72" (1200 - 1800 mm)	FL-L	76470
XL Flex-Lifter 72" - 96" (1800-2400 mm)	FL-XL	76983

Flex-Lifter™ Conveyor Belt Lifter

The Flexco® Flex-Lifter makes the job of lifting the conveyor belt easy and safe. Using two Flex-Lifters, the belt can be quickly lifted out of the way to install the impact bed. The Flex-Lifter has the highest safe lift rating available at 4000 lbs. (1800 kg) on Medium and Large, and 6000 (2725 kg) on XL. And it's versatile. It can also be used to lift topside or return side belt for splicing, roller replacement or other maintenance jobs. Available in three sizes: Medium for belt widths 36" - 60" (900 - 1500mm), Large for belt widths 48" - 72" (1200 - 1800mm), and XL for belt widths 72" - 96" (1800 - 2400mm).

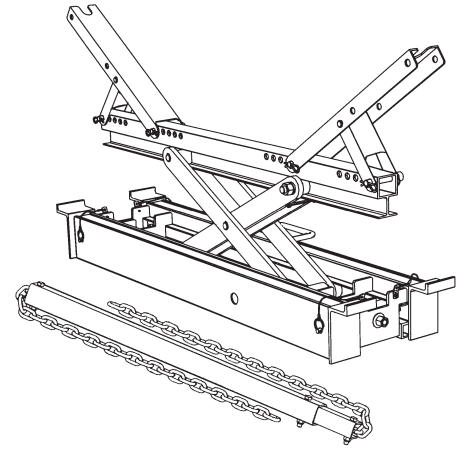

Impact Bed Shim Kits

Description	Ordering Number	Item Code	Wt. Lbs.
DRX200 Shim Kit	SHIM-KITL	77548	13.6
DRX750 Shim Kit	SHIM-KITM	77549	20.4
DRX1500 Shim Kit	SHIM-KITH	77550	27.2

Shims

Depending on your idler rating and size, shimming may be required. See charts below for quantity of kits required.

Shim Chart - CEMA C or D Idlers

Impact Bed Size	Cema C or D, 5" (125mm) IDLERS	Cema C or D, 6" (150mm) IDLERS
DRX200: 24"- 36" (600-900mm)	Shim idler up 1/2" (13mm)	No Kits Required
DRX200: 42"- 72" (1050-1800mm)	No Kits Required	Use (1) SHIM-KITL; Shim up 1/2" (13mm)
DRX750: 24"- 36" (600-900mm)	Shim idler up 1/2" (13mm)	No Kits Required
DRX750: 42"- 72" (1050-1800mm)	No Kits Required	Use (1) SHIM-KITM; Shim up 1/2" (13mm)
DRX1500: 24"- 36" (600-900mm)	Shim idler up 1/2" (13mm)	No Kits Required
DRX1500: 42"- 72" (1050-1800mm)	No Kits Required	Use (1) SHIM-KITH; Shim up 1/2" (13mm)
DRX3000: 42"-60" (1050-1500mm)	Shim idler up 2" (50mm)	Shim idler up 1.5" (38mm)
DRX3000: 72"-96" (1800-2400mm)	Shim idler up 2.5" (63mm)	Shim idler up 2" (50mm)

Impact Bed Handy Wrench

Description	Ordering Number	Item Code	Wt. Lbs.
Impact Bed Handy Wrench	HW-IMPB	76939	1.6

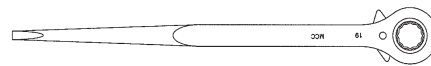

Impact Bed Handy Wrench

A handy ratcheting wrench with two common sizes (3/4" and 15/16" or 19mm and 24mm) for easier installation and maintenance of impact beds.

Shim Chart - CEMA E Idlers

Impact Bed Size	CEMA E, 6" (150mm) IDLERS	CEMA E, 7" (175mm) IDLERS
DRX200: 36"-60" (900-1500mm)	Use (3) SHIM-KITL; Shim up 1.5" (38mm)	Use (4) SHIM-KITL; Shim up 2" (50mm)
DRX200: 72" (1800mm)	Use (4) SHIM-KITL; Shim up 2" (50mm)	Use (5) SHIM-KITL; Shim up 2.5" (63mm)
DRX750: 36"-60" (900-1500mm)	Use (3) SHIM-KITM; Shim up 1.5" (38mm)	Use (4) SHIM-KITM; Shim up 2" (50mm)
DRX750: 72" (1800mm)	Use (4) SHIM-KITM; Shim up 2" (50mm)	Use (5) SHIM-KITM; Shim up 2.5" (63mm)
DRX1500: 36"-60" (900-1500mm)	Use (3) SHIM-KITH; Shim up 1.5" (38mm)	Use (4) SHIM-KITH; Shim up 2" (50mm)
DRX1500: 72" (1800mm)	Use (4) SHIM-KITH; Shim up 2" (50mm)	Use (5) SHIM-KITH; Shim up 2.5" (63mm)
DRX3000: 42"-60" (1050-1500mm)	No Shim Required	No Shim Required
DRX3000: 72"-96" (1800-2400mm)	No Shim Required	No Shim Required

Section 4 - Installation Instructions

4.1 DRX™ Impact Bed

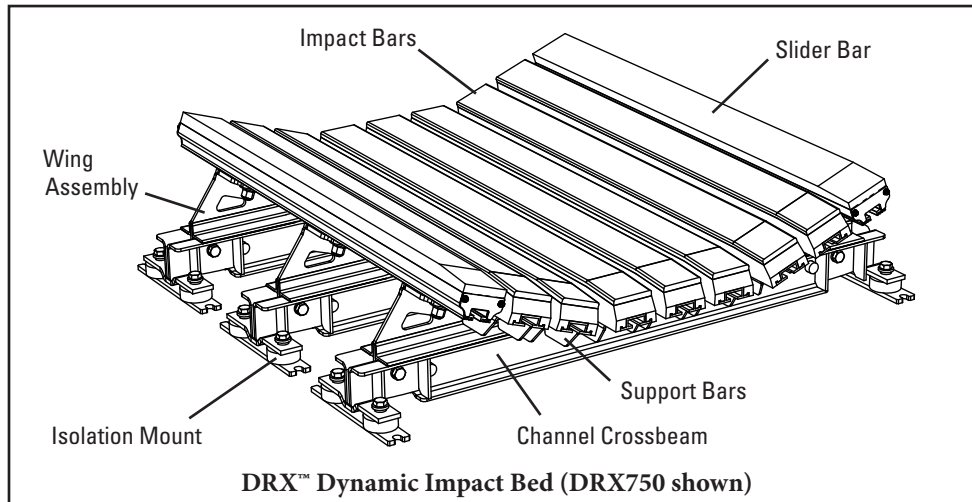

Physically lock out and tag the conveyor at the power source before you begin installation.

Caution: Components may be heavy. Use safety approved lifting procedures.

Before Installation: Inspect structure; confirm CEMA rating. Shim bed or idlers per Table 1. **NOTE:** Installation of an idler is required 1-6" (25-150mm) before and after a Flexco® DRX™ Impact Bed (Fig. 1). If more than one impact bed is used, idlers should be installed between every one or two beds.

- Tools Needed:**
- 15/16" (19mm) open-ended wrench
 - 15/16" (19mm) drive socket with socket or impact wrench
 - 90° square
 - Come-along
 - Grease Pencil
 - Measuring Tape
 - Cutting torch
 - Flex-Lifter (helpful)
 - Welder

If CEMA rating is unknown, measure the lead and trail idler for height from top of center roll to the top of conveyor structure. Table 2 shows the nominal center height required for the idler based on belt width. If incorrect, shim idler(s) to the height shown in Table 2.

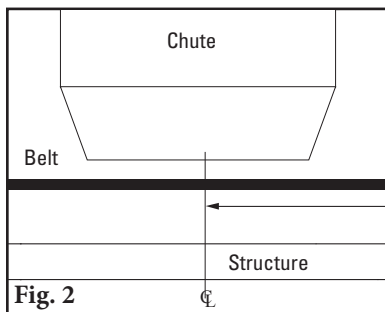
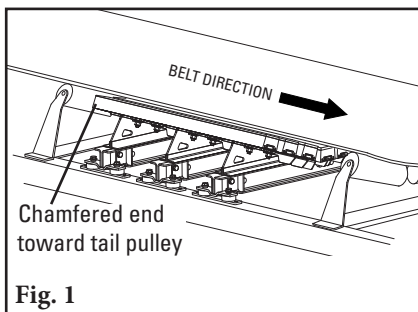

1. **Free the area of previous system.** Remove material (idlers, etc.) from the area of desired installation. Loosen or remove skirting material for extra space. If available, use Flex-Lifters before and after the load zone to lift the belt out of the way.
2. **Visually locate center of loading zone.** Determine the center of the load zone on one side of the structure and mark (Fig. 2).

Table 1: Shim Requirements

Idler Diameter (CEMA C or D)	24"-36" (600-900mm) Belt Width	42"-72" (1050-1800mm) Belt Width	
	5" (125mm)	Idler up 1/2" (13mm)	No shim
6" (150mm)	No shim	Bed up 1/2" (13mm)	
Idler Diameter (CEMA E)	36"-60" (900-1500mm) Belt Width	72" (1800mm) Belt Width	
	6" (150mm)	Bed up 1.5" (38mm)	Bed up 2" (50mm)
	7" (175mm)	Bed up 2" (50mm)	Bed up 2.5" (64mm)

Table 2: Nominal Center Roll Height

Belt Width	24"-48" (300-600mm)	54"-60" (1350-1500mm)	72" (1800mm)
Height	9" (229mm)	9-1/4" (235mm)	9-1/2" (241mm)



Section 4 - Installation Instructions

4.1 DRX™ Impact Bed (cont.)

- Locate mounting templates.** Measure and mark where the center of the template will sit on the structure by measuring belt width + 9" (230mm) and centering this on the structure (Fig. 3a). Lengthwise, center template over the center mark from Step 2. Mark and measure from the notch in end of template to a fixed point on the structure, and then transfer this dimension to the opposite side of the structure. Align notches on mounting templates with marks on structure and mark all the holes (Fig. 3b). Drill or torch holes. Included mounting bolts should fit freely through the holes.

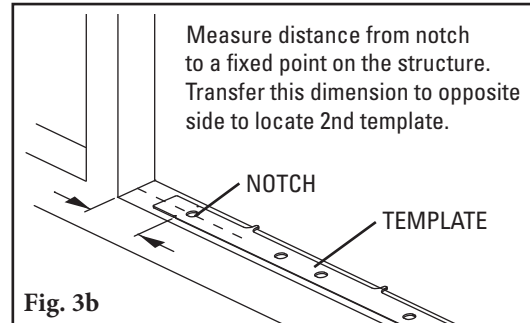
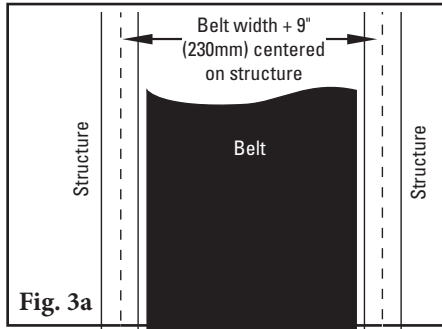

- Disassemble wing assemblies.** Remove the center mounting bolt and the two outer flange bolts. Slide out and remove the wing assembly on each channel crossbeam (Fig. 4).
- Install channel crossbeams.** Position all channel crossbeams onto the conveyor structure, aligning with the mounting holes from Step 3. Insert the channel crossbeam mounting bolt and leave finger tight (Fig. 5). Use shims under isolation mounts if needed (see Table 1). Verify height of center roller on leading and trailing idlers in load zone.

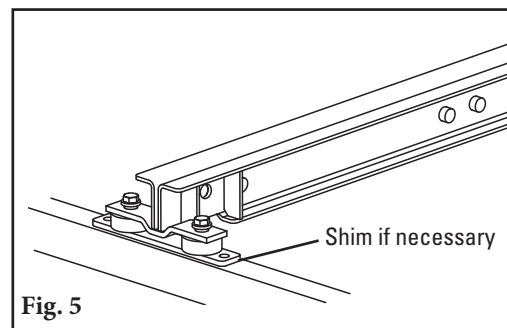
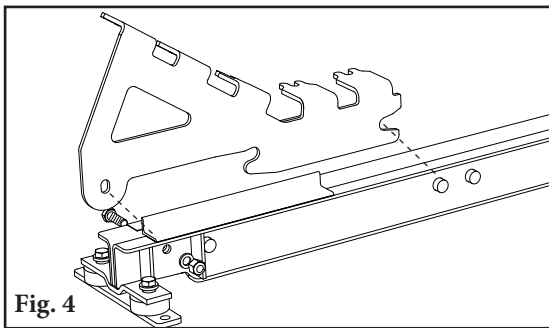

- Square up all channel crossbeams.** With a square, ensure the first channel crossbeam is perpendicular to the conveyor structure and tighten in place. Next, space the remaining channel crossbeams with the correct center-to-center spacing. Use tabs on provided fixture to set spacing (Fig. 6a). If this is not possible, use dimensions in Table 3 (Fig. 6b). Tighten all bolts in place. **NOTE: Spacing must be exact (+/- 1/16" or 1.6mm). This step is critical to a successful install.**

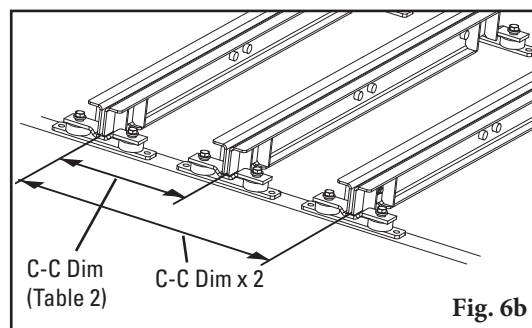
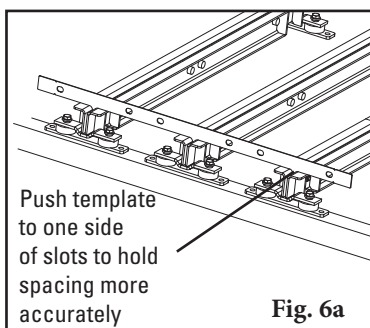

Table 3: Center-to-Center (C-C) Dimensions

	4 ft. (1.2M)	5 ft. (1.5M)
DRX200	32" (812.8mm)	44" (1117.6mm)
DRX750	16" (406.4mm)	22" (558.8mm)
DRX1500	12.5" (317.5mm)	16" (406.4mm)

Section 4 - Installation Instructions

4.1 DRX™ Impact Bed (cont.)

7. **Install wing assembly into the “service position”.** Slide the wing assembly into the channel crossbeams with the tabs facing the tail pulley (Fig. 7). Slide over the welded pin and pull back to engage. This is called the “service position”.

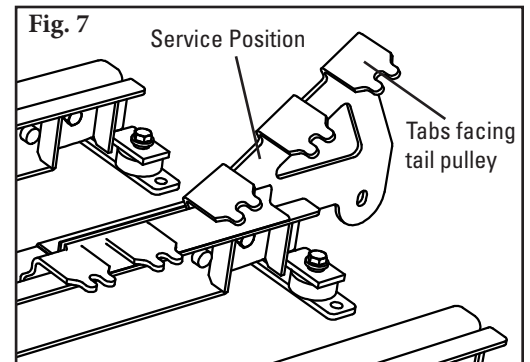

8. **Install impact bars.** Starting with the center bars first, place the impact bar in place. Position studs between the tabs in the wing assembly while confirming the chamfer of the impact bar is positioned at the tail pulley end of the bed (Fig. 8).

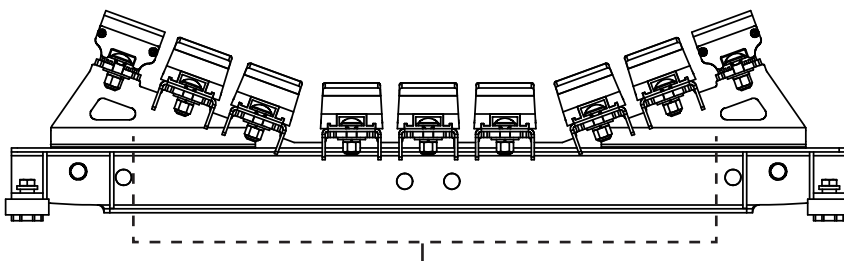
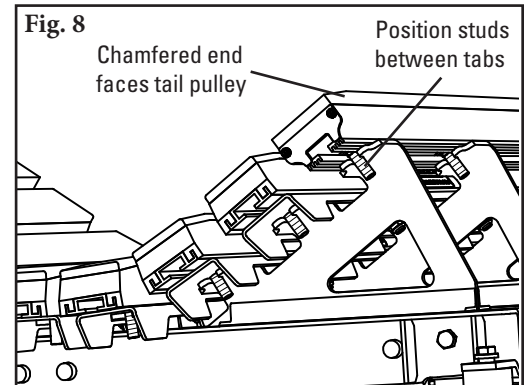

DRX™ impact beds have bar supports under all white impact bars.

Section 4 - Installation Instructions

4.1 DRX™ Impact Bed (cont.)

9. Fasten all impact bars. With all impact bars correctly positioned on the wing assemblies, install on each stud a flat washer, lock washer and a nylock nut. Tighten to 100 ft-lb (135 N/m) torque.

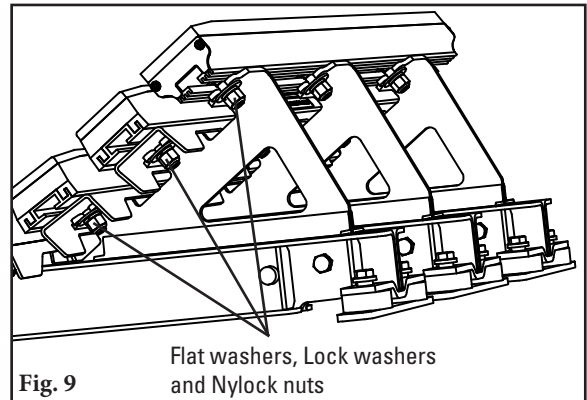

10. Move wing assemblies into operating position. Slide the complete side assembly back and forth on the crossbeams to ensure that there is no binding. If there is binding, repeat Step 6. Slide in until the outer mounting holes of the wing assembly align with the inner mounting holes of the cross stringer. A come-along may be necessary for the last inch to line up the mounting holes. Reinsert the center retaining bolt in each wing assembly and tighten to 100 ft-lb (135 N/m) torque.

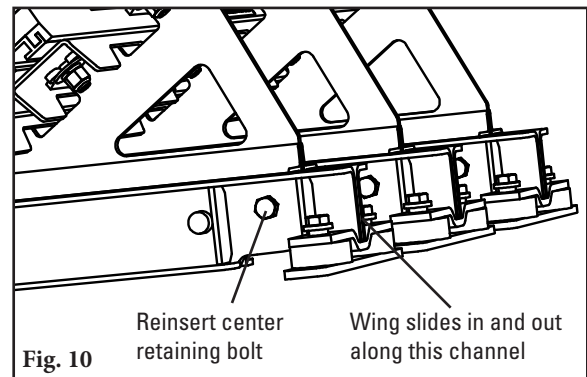

11. Confirm correct clearance between chute and belt. Reference Table 2 to confirm center roll height. On beds with full bars, this should provide a 1/4" (6mm) gap to lift the belt (Fig. 11). If this gap is incorrect, shim idlers or bed accordingly.

Table 2: Nominal Center Roll Height

Belt Width	24"-48" (300-600mm)	54"-60" (1350-1500mm)	72" (1800mm)
Height	9" (229mm)	9-1/4" (235mm)	9-1/2" (241mm)

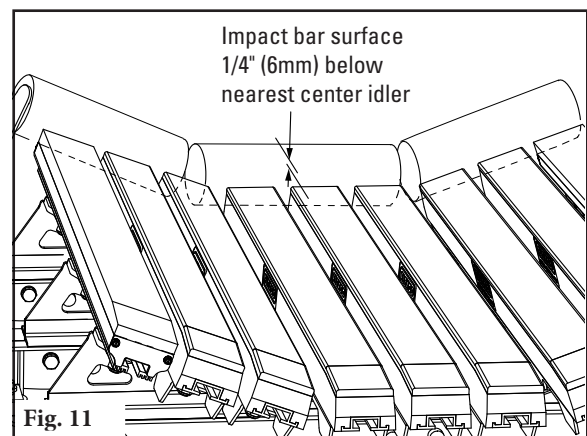

12. Readjust skirt rubber to maintain a good seal against impact bed. Replace all protective guarding around load zone.

Section 5 - Pre-Operation Checklist and Testing

5.1 Pre-Op Checklist

- Recheck that all fasteners are tight
- Check that empty belt is 1/4" (6mm) above the impact bars
- Apply all supplied labels
- Be sure that all installation materials and tools have been removed from the belt and conveyor area

5.2 Test Run the Conveyor

- Run the conveyor for at least 15 minutes and confirm the skirt rubber is properly sealing the transfer point. Adjust skirt rubber as needed.

Section 6 - Maintenance

Flexco impact beds are designed to operate with minimum maintenance. However, to maintain superior performance some service is required. When the impact bed is installed a regular maintenance program should be set up. This program will ensure that the impact bed operates at optimal efficiency, and problems can be identified and fixed before any damage is done to the belt, the bed, other conveyor components, or structure.

All safety procedures for inspection of equipment (stationary or operating) must be observed. The DRX™ Impact Bed operates in the loading zone of the conveyor system and is in direct contact with the moving belt. Only visual observations can be made while the belt is running. Service tasks can be done only with the conveyor stopped and by observing the correct lockout/tagout procedures.

6.1 New Installation Inspection

After the impact bed has run for a few days a visual inspection should be made to ensure the bed is performing properly. Make adjustments as needed.

6.2 Routine Visual Inspection (every 2-4 weeks)

A visual inspection of the impact bed can determine:

- If the skirt rubber is adequately keeping the chute area sealed
- If the impact bars are worn out and need to be replaced
- If there are excessive materials building up around the impact bed
- If there is damage to the impact bed, belt or other conveyor components

If any of the above conditions exist, a determination should be made on when the conveyor can be stopped for cleaner maintenance.

6.3 Routine Physical Inspection (every 6-8 weeks)

When the conveyor is not in operation and properly locked and tagged out, a physical inspection of the cleaner to perform the following tasks:

- Clean material buildup off the impact bed and conveyor structure.
- Closely inspect each impact bar for wear and damage. Bars are worn when the UHMW is worn down to or near the rubber. Replace if needed.
- Check the impact bed frame for damage.
- Inspect all fasteners for tightness and wear. Tighten or replace as needed.
- Inspect skirt rubber and adjust as needed to compensate for impact bar wear.
- When maintenance tasks are completed, test run the conveyor to ensure the impact bed is performing properly.

Section 6 - Maintenance

6.4 Impact Bar Replacement Instructions

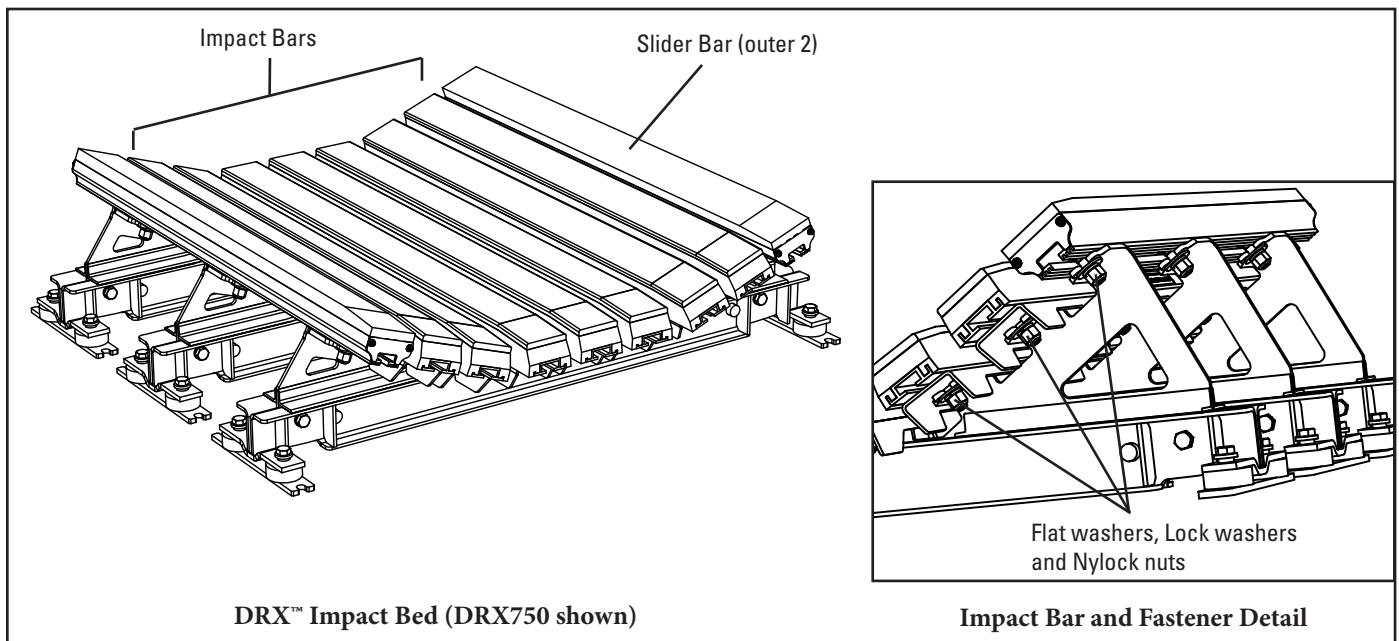

Physically lock out and tag the conveyor at the power source before you begin maintenance.

Tools Needed:

- (2) 15/16" (24mm) wrenches or crescent wrenches
- Broom, wire brush and/or putty knife (for cleaning bed and structure)
- Come-along

1. **Remove tension.** Use a Flexco® Belt Lifter or other appropriate lifting equipment to lift the belt off the impact bed.
2. **Loosen bed halves.** Remove bolt from each side of each cross-stringer (Fig. 2).
3. **Slide each half of bed out.** Pull out half of the bed on each side until they engage the slide stop (Fig. 3). This may require a come-along to break it free.
4. **Inspect bars.** Check to see which bars are worn or damaged and need to be replaced.

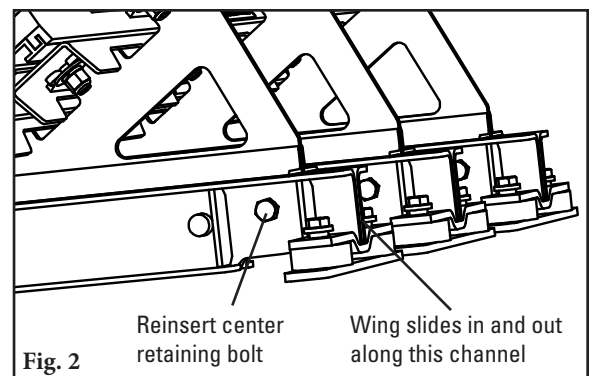

Fig. 2

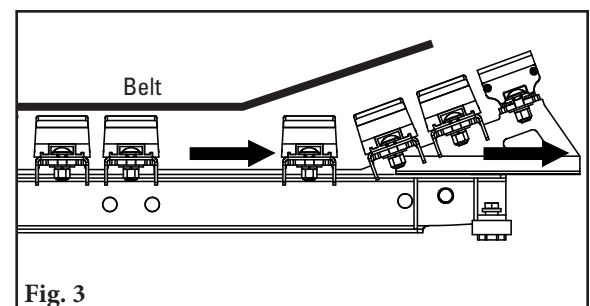

Fig. 3

Section 6 - Maintenance

6.4 Impact Bar Replacement Instructions (cont.)

5. **Remove worn bars.** Loosen and remove nuts at each cross stringer and remove the impact bar and bar support, if present (Fig. 5).

6. **Remove support bar if attached.** Remove the nuts holding the support in place and attach to the new impact bar (Fig. 6).

7. **Install new bar and support onto the bed.** Place the new impact bar and bar support onto the bed with the chamfered end facing the tail pulley (Fig. 7). Line up the bolts and tighten the bars to the cross stringers.

8. **Slide bed half back to center.** Push the bed half back into the bed until the holes in the wing plates and the cross-stringers line up (Fig. 8). **NOTE:** If the holes do not line up, a come-along may need to be used to pull from the opposite side of the bed until the holes are in line. Reinstall bolts and tighten.

Test run the conveyor. Run the conveyor for a few minutes and inspect to ensure that the bed is performing properly. Make adjustments as necessary.

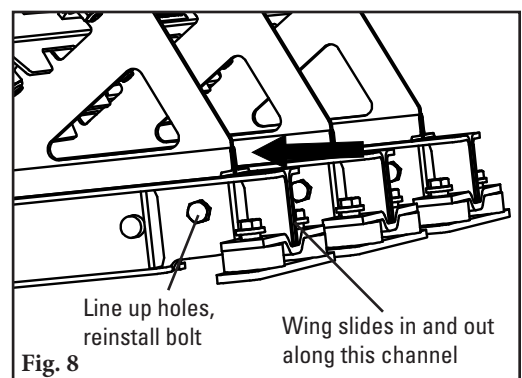
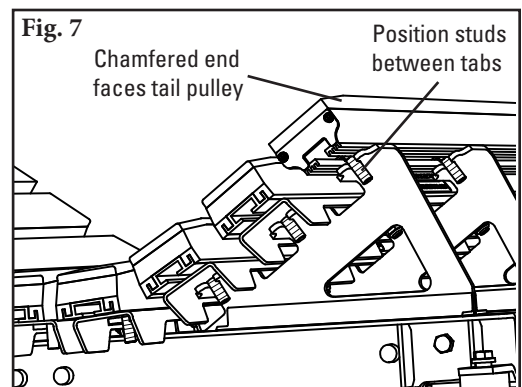
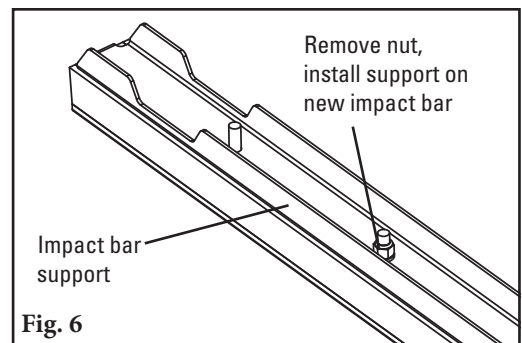
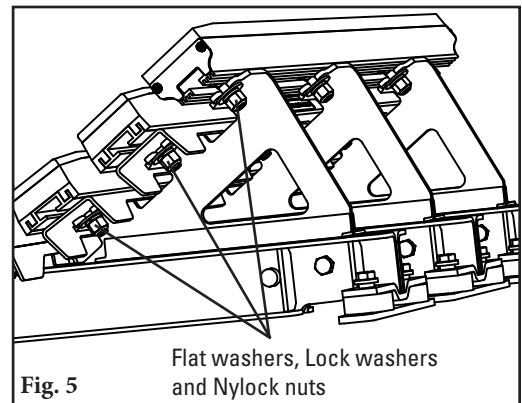

Section 6 - Maintenance

6.5 Maintenance Log

Conveyor Name/No. _____

Date: _____ Work done by: _____ Service Quote #: _____

Activity: _____

Date: _____ – _____ Work done by: _____ Service Quote #: _____

Activity: _____

Date: _____ – _____ Work done by: _____ Service Quote #: _____

Activity: _____

Date: _____ – _____ Work done by: _____ Service Quote #: _____

Activity: _____

Date: _____ – _____ Work done by: _____ Service Quote #: _____

Activity: _____

Date: _____ – _____ Work done by: _____ Service Quote #: _____

Activity: _____

Date: _____ – _____ Work done by: _____ Service Quote #: _____

Activity: _____



Section 6 - Maintenance

6.6 Impact Bed Maintenance Checklist

Site: _____ Inspected by: _____ Date: _____

DRX Impact Bed: _____ Serial Number: _____

Beltline Information:

Beltline Number: _____ Belt Condition: _____

Belt	<input type="checkbox"/>	24"	<input type="checkbox"/>	30"	<input type="checkbox"/>	36"	<input type="checkbox"/>	42"	<input type="checkbox"/>	48"	<input type="checkbox"/>	54"	<input type="checkbox"/>	60"	<input type="checkbox"/>	72"
Width:	(600mm)	(750mm)	(900mm)	(1050mm)	(1200mm)	(1350mm)	(1500mm)	(1800mm)								

Transition Distance (back of bed to center of tail pulley): _____ Belt Speed: _____ Belt Thickness: _____

Distance to Leading Idler: _____ Distance to Trailing Idler: _____

Vertical Distance between top of nearest idler and top surface of center impact bars: _____

Impact Bar Life:

Date bars installed: _____ Date bars inspected: _____ Estimated bar life: _____

Bar Condition: _____ inches of top cover remaining: _____

Impact Bed Frame Condition:

Good Bent Rusted

Overall Impact Bed Performance: (Rate the following 1 - 5, 1= very poor - 5 = very good)

Appearance: Comments: _____

Location: Comments: _____

Maintenance: Comments: _____

Performance: Comments: _____

Other comments: _____

Section 7 - Troubleshooting

Problem	Possible Cause	Possible Solutions
Bars wearing out too fast	Impact bars are not at 1/4" (6mm) below leading and trailing idlers	Adjust/shim as needed to correct dimension
	More than two beds in a row without idler between	Add an idler between at least every other bed to lift the belt back up
	Leading idler does not match troughing angle	Correct the angle of the leading idler to match the bed
Vibration or noise	Belt rubbing too hard on UHMW impact bar covers	Verify height of leading/trailing idlers
	Material buildup under bed	Clean up buildup and adjust skirting
	Skirt rubber pushing too hard on belt	Adjust skirt rubber
Bars deforming	Larger material than specified is flowing through transition (under-specified bed)	Replace with a heavier-duty version of impact bed or add additional bar supports
Bar damage	Mechanical splice damaging UHMW top covers	Repair, skive or replace splice

For more information on selection and proper usage of impact beds, contact Flexco Customer Service.

Section 8 - Specs and CAD Drawings

8.1 Specifications and Guidelines

Bed Length: 4' and 5' (1.2M and 1.5M)

Troughing Angles: 20° and 35°

Bed Specs per lump size and drop height needs:

(Per Conveyor Equipment Manufacturers Association (CEMA) guidelines)

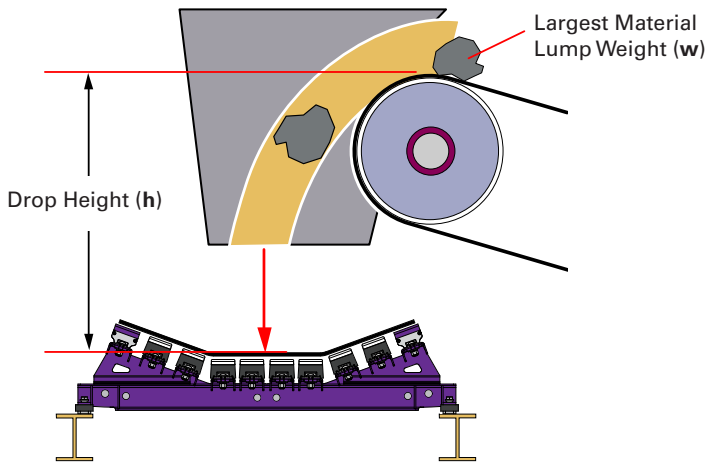

Impact Energy Calculation:

$$\begin{array}{r}
 \text{Lump weight} \quad \underline{\hspace{2cm}} \quad \text{lb} \\
 \times \text{Drop length} \quad \underline{\hspace{2cm}} \quad \text{ft} \\
 \hline
 \text{Total} \quad \underline{\hspace{2cm}} \quad \text{lb-ft}
 \end{array}$$

Match lb-ft to bed rating:

- Up to 200 lb-ft (25 kg-m) DRX 200
- 200 to 750 lb-ft (25 to 100 kg-m) DRX 750
- 750 to 1500 lb-ft (100 to 200 kg-m) DRX 1500
- 1500 to 3000 lb-ft (200 to 400 kg-m) DRX 3000

Slider Bars and Impact Bars per Belt Width (DRX200, 750, 1500)

Belt Width - in.	24	30	36	42	48	54	60	72
Belt Width - mm	600	750	900	1050	1200	1350	1500	1800
SLIDER BARS								
DRX200, 750, 1500	2	2	2	2	2	2	2	4
IMPACT BARS								
DRX200, 750, 1500	4	4	5	7	8	10	11	12

Impact Bar Supports and Bolt Kits per Belt Width (DRX200, 750, 1500)

Belt Width- in.	24	30	36	42	48	54	60	72
Belt Width- mm	600	750	900	1050	1200	1350	1500	1800
BAR SUPPORTS								
DRX200, 750, 1500	4	4	5	7	8	10	11	12
BOLT KITS								
DRX200	16	16	19	25	28	34	37	44
DRX750	26	26	31	41	46	56	61	72
DRX1500	32	32	38	50	56	68	74	88

Section 8 - Specifications and CAD Drawings

8.2 CAD Drawing - DRX200

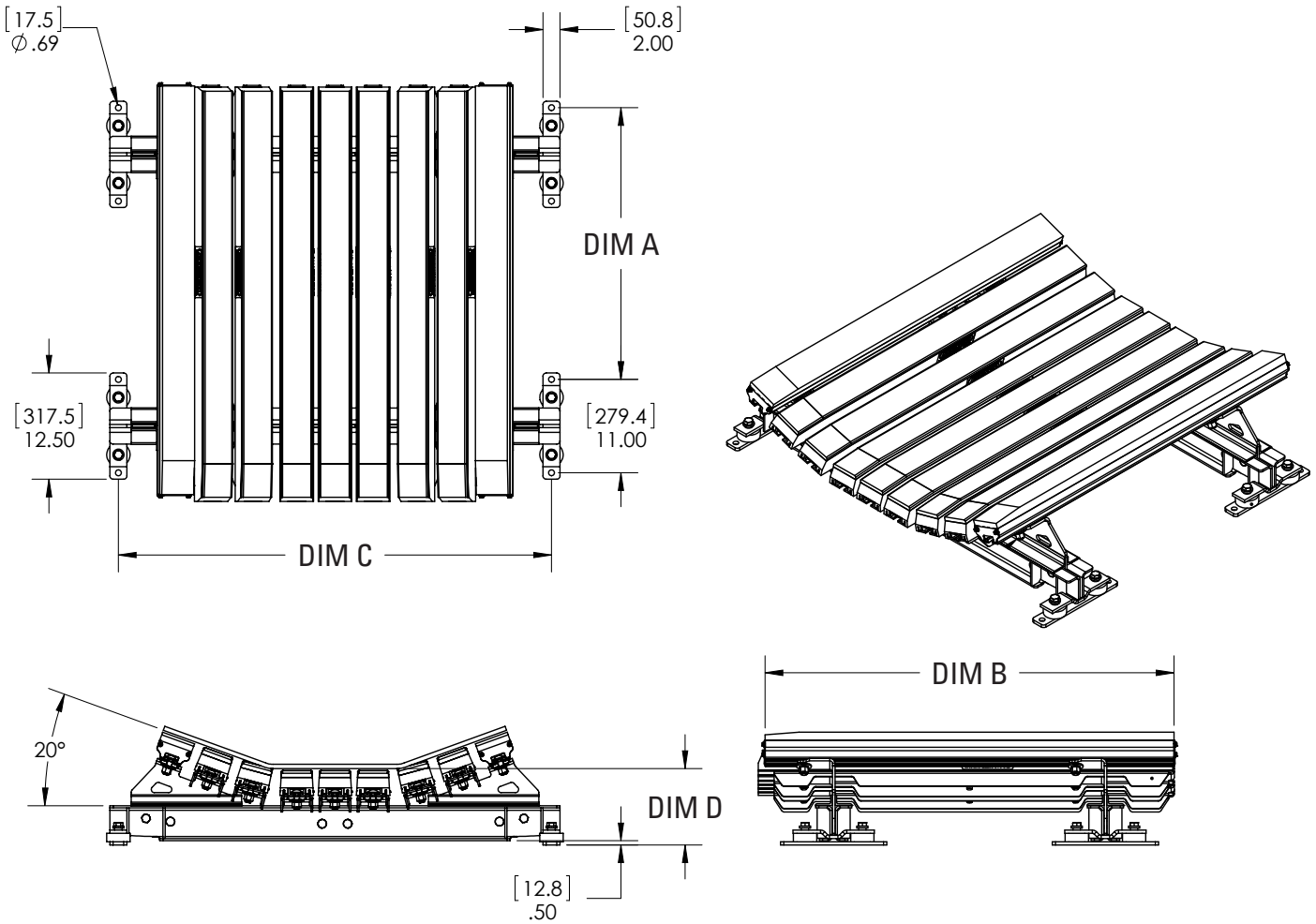

Bed Length 4' (1.2 M)		Bed Length 5' (1.5 M)		Bed Width	Dim C	Dim D
Dim A	Dim B	Dim A	Dim B			
32" (812.8mm)	48.14" (1222.8mm)	44" (1117.6mm)	58.38" (1482.9mm)	24" (600mm)	33" (838mm)	9" (229mm)
				30" (750mm)	39" (991mm)	9" (229mm)
				36" (900mm)	45" (1143mm)	9" (229mm)
				42" (1050mm)	51" (1295mm)	9" (229mm)
				48" (1200mm)	57" (1448mm)	9" (229mm)
				54" (1350mm)	63" (1600mm)	9.25" (235mm)
				60" (1500mm)	69" (1753mm)	9.25" (235mm)
				72" (1800mm)	81" (2057mm)	9.5" (241mm)

Section 8 - Specifications and CAD Drawings

8.2 CAD Drawing - DRX750

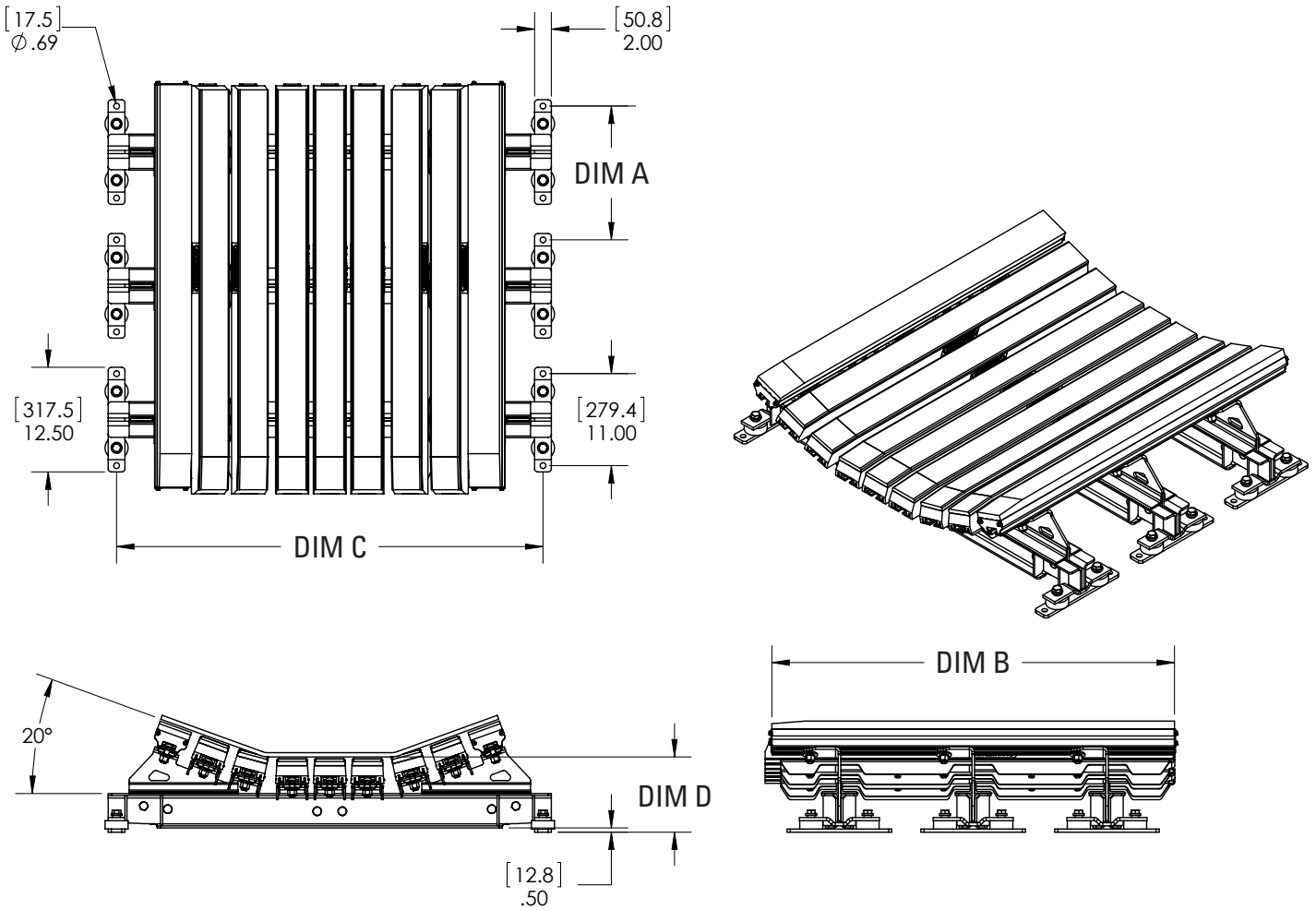

Bed Length 4' (1.2 M)		Bed Length 5' (1.5 M)		Bed Width	Dim C	Dim D
Dim A	Dim B	Dim A	Dim B			
16" (406.4mm)	48.14" (1222.8mm)	22" (558.8mm)	58.38" (1482.9mm)	24" (600mm)	33" (838mm)	9" (229mm)
				30" (750mm)	39" (991mm)	9" (229mm)
				36" (900mm)	45" (1143mm)	9" (229mm)
				42" (1050mm)	51" (1295mm)	9" (229mm)
				48" (1200mm)	57" (1448mm)	9" (229mm)
				54" (1350mm)	63" (1600mm)	9.25" (235mm)
				60" (1500mm)	69" (1753mm)	9.25" (235mm)
				72" (1800mm)	81" (2057mm)	9.5" (241mm)

Section 8 - Specifications and CAD Drawings

8.2 CAD Drawing - DRX1500

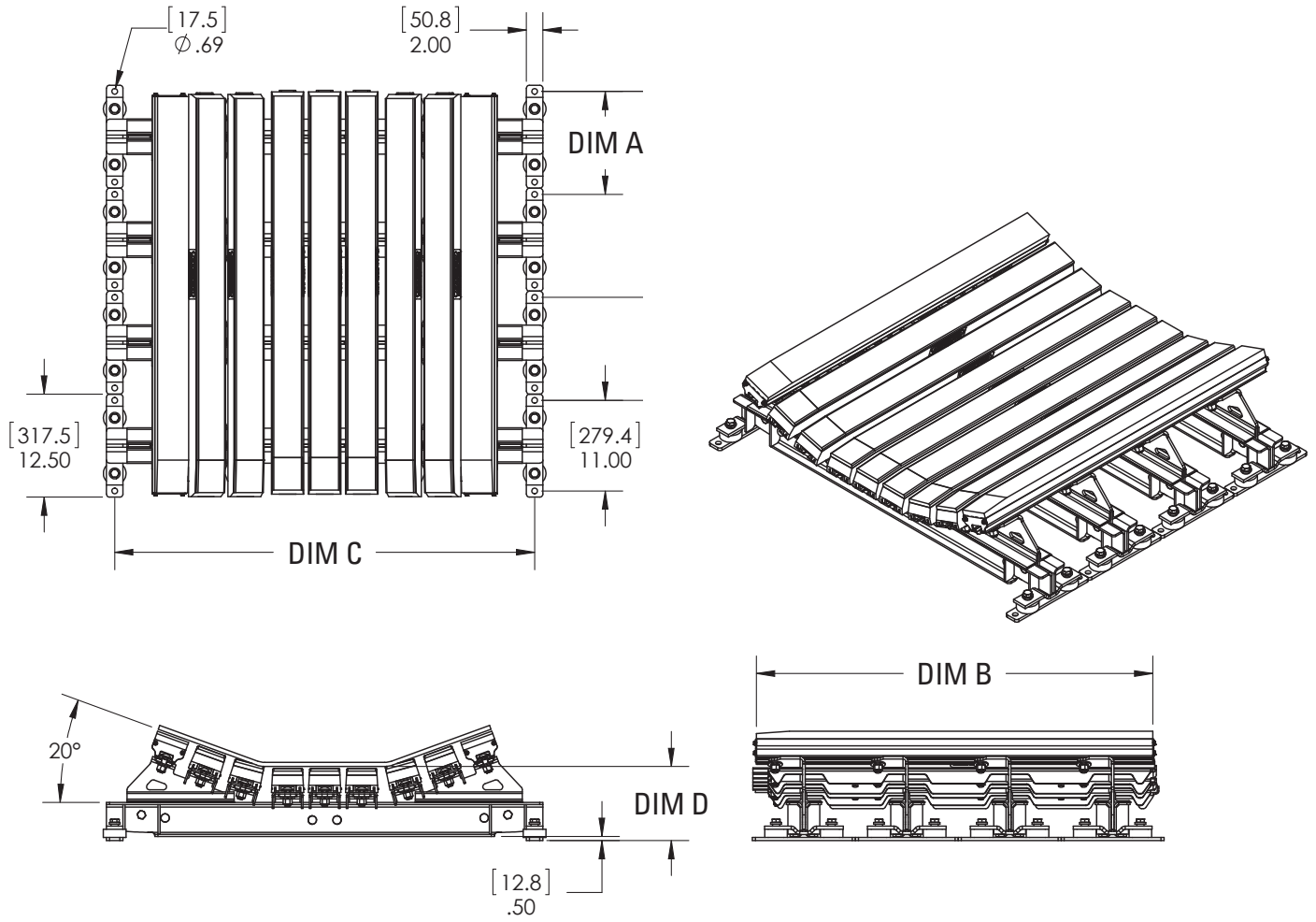

Bed Length 4' (1.2 M)		Bed Length 5' (1.5 M)		Bed Width	Dim C	Dim D
Dim A	Dim B	Dim A	Dim B			
12.5" (317.5mm)	48.14" (1222.8mm)	16" (406.4mm)	58.38" (1482.9mm)	24" (600mm)	33" (838mm)	9" (229mm)
				30" (750mm)	39" (991mm)	9" (229mm)
				36" (900mm)	45" (1143mm)	9" (229mm)
				42" (1050mm)	51" (1295mm)	9" (229mm)
				48" (1200mm)	57" (1448mm)	9" (229mm)
				54" (1350mm)	63" (1600mm)	9.25" (235mm)
				60" (1500mm)	69" (1753mm)	9.25" (235mm)
				72" (1800mm)	81" (2057mm)	9.5" (241mm)

Section 9 - Replacement Parts

9.1 Replacement Parts List - DRX200

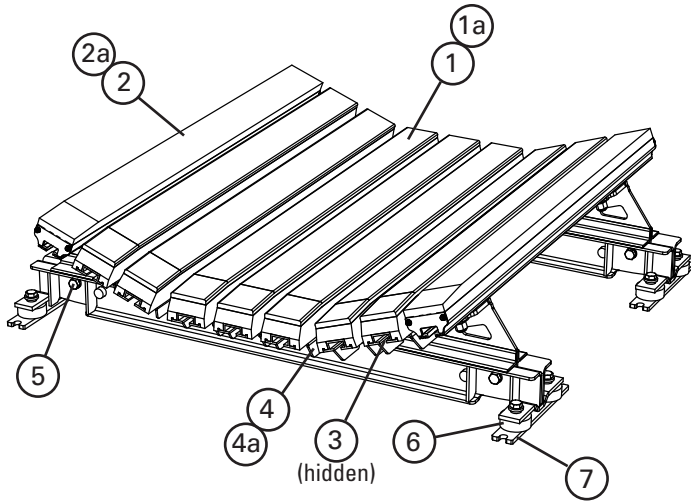

* Belt width + 9" (230mm) = Structure width

Replacement Parts

REF	DESCRIPTION	ORDERING NUMBER	ITEM CODE	WT. LBS.
1	Impact Bar, 4' (1.2M)	IB4	76926	17.0
1a	Impact Bar, 5' (1.5M)	IB5	76927	21.2
2	Slider Bar, 4' (1.2M)	SB4	78789	20.0
2a	Slider Bar, 5' (1.5M)	SB5	78790	24.1
3	Impact Bar Bolt Kit incl. (1) ea 5/8" carriage bolt, square washer, flat washer, lock washer, Nylock nut	IBBK	76928	0.5
4	Impact Bar Support -L 4' incl. (1) ea bar support, carriage bolt, square washer, lock washer, Nylock nut	IBS-L4	76929	16.8
4a	Impact Bar Support -L 5' incl. (1) ea bar support, carriage bolt, square washer, lock washer, Nylock nut	IBS-L5	76930	21.0
5	Sliding Support Arm Bolt Kit incl. (2) 2" bolts, (2) lock washers, (2) Nylock nuts	ISABK-LMH	77529	2.0
6	Isolation Mount Kit	IMK	76936	3.8
7	DRX200 Shim Kit (incl. 4 shims)	SHIM-KITL	77548	13.6

Lead time: 1 working day

Impact Bed Size	Cema C or D 5" (125mm) IDLERS	CEMA C or D 6" (150mm) IDLERS
DRX200: 24"- 36" (600-900mm)	Shim idler up 1/2" (13mm)	No Kits Required
DRX200: 42"- 72" (1050-1800mm)	No Kits Required	Use (1) SHIM-KITL; Shim up 1/2" (13mm)

Impact Bed Size	CEMA E 6" (150mm) IDLERS	CEMA E 7" (175mm) IDLERS
DRX200: 36"-60" (900-1500mm)	Use (3) SHIM-KITL; Shim up 1.5" (38mm)	Use (4) SHIM-KITL; Shim up 2" (50mm)
DRX200: 72" (1800mm)	Use (4) SHIM-KITL; Shim up 2" (50mm)	Use (5) SHIM-KITL; Shim up 2.5" (63mm)

Replacement Bars, Bar Supports and Bolt Kits Required per Belt Width - DRX200

in.	24	30	36	42	48	54	60	72
mm	600	750	900	1050	1200	1350	1500	1800
Slider Bars Required	2	2	2	2	2	2	2	4
Impact Bars Required	4	4	5	7	8	10	11	12
Impact Bar Supports Required	4	4	5	7	8	10	11	12
Impact Bar Bolt Kits Required	16	16	19	25	28	34	37	44

Section 9 - Replacement Parts

9.2 Replacement Parts List - DRX750

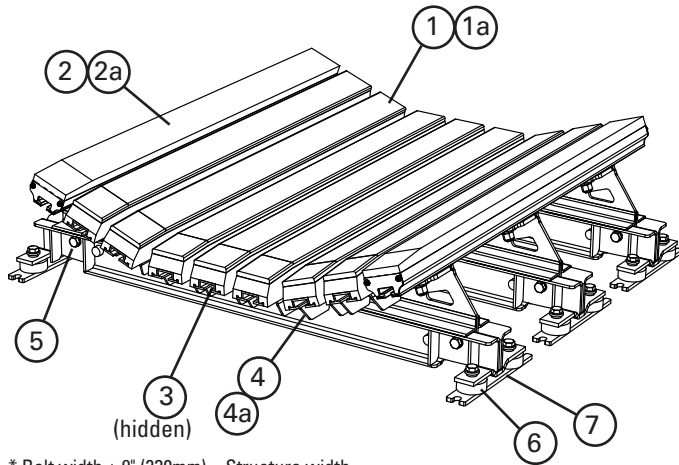

Replacement Parts

REF	DESCRIPTION	ORDERING NUMBER	ITEM CODE	WT. LBS.
1	Impact Bar, 4' (1.2M)	IB4	76926	17.0
1a	Impact Bar, 5' (1.5M)	IB5	76927	21.2
2	Slider Bar, 4' (1.2M)	SB4	78789	20.0
2a	Slider Bar, 5' (1.5M)	SB5	78790	24.1
3	Impact Bar Bolt Kit (incl. (1) ea 5/8" carriage bolt, square washer, flat washer, lock washer, Nylock nut)	IBBK	76928	0.5
4	Impact Bar Support -M 4' (incl. (1) bar support, (2) ea carriage bolt, square washer, lock washer, Nylock nut)	IBS-M4	76931	16.9
4a	Impact Bar Support -M 5' (incl. (1) bar support, (2) ea carriage bolt, square washer, lock washer, Nylock nut)	IBS-M5	76932	21.2
5	Sliding Support Arm Bolt Kit (incl. (2) 2" bolts, (2) lock washers, (2) Nylock nuts)	ISABK-LMH	77529	2.0
6	Isolation Mount Kit	IMK	76936	3.8
7	DRX750 Shim Kit (incl. 6 shims)	SHIM-KITM	77549	20.4

Lead time: 1 working day

Impact Bed Size	Cema C or D 5" (125mm) IDLERS	CEMA C or D 6" (150mm) IDLERS
DRX750: 24"- 36" (600-900mm)	Shim idler up 1/2" (13mm)	No Kits Required
DRX750: 42"- 72" (1050-1800mm)	No Kits Required	Use (1) SHIM-KITM; Shim up 1/2" (13mm)

Impact Bed Size	CEMA E 6" (150mm) IDLERS	CEMA E 7" (175mm) IDLERS
DRX750: 36"-60" (900-1500mm)	Use (3) SHIM-KITM; Shim up 1.5" (38mm)	Use (4) SHIM-KITM; Shim up 2" (50mm)
DRX750: 72" (1800mm)	Use (4) SHIM-KITM; Shim up 2" (50mm)	Use (5) SHIM-KITM; Shim up 2.5" (63mm)

Replacement Bars, Bar Supports and Bolt Kits Required per Belt Width - DRX750

in.	24	30	36	42	48	54	60	72
mm	600	750	900	1050	1200	1350	1500	1800
Slider Bars Required	2	2	2	2	2	2	2	4
Impact Bars Required	4	4	5	7	8	10	11	12
Impact Bar Supports Required	4	4	5	7	8	10	11	12
Impact Bar Bolt Kits Required	26	26	31	41	46	56	61	72

Section 9 - Replacement Parts

9.3 Replacement Parts List - DRX1500

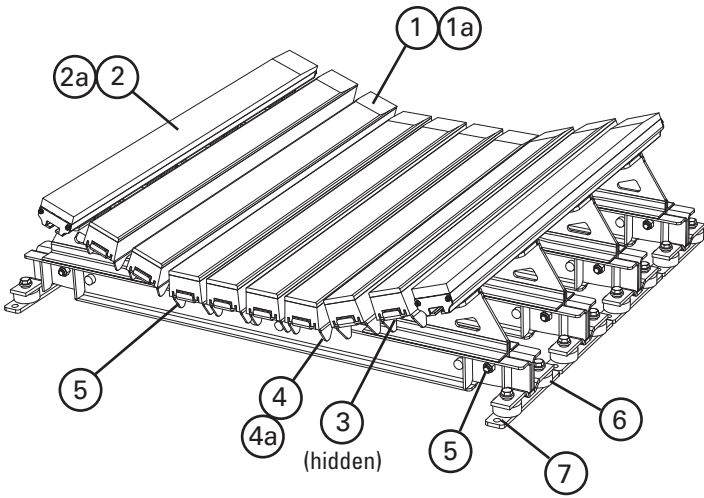

* Belt width + 9" (230mm) = Structure width

Replacement Parts

REF	DESCRIPTION	ORDERING NUMBER	ITEM CODE	WT. LBS.
1	Impact Bar, 4' (1.2M)	IB4	76926	17.0
1a	Impact Bar, 5' (1.5M)	IB5	76927	21.2
2	Slider Bar, 4' (1.2M)	SB4	78789	20.0
2a	Slider Bar, 5' (1.5M)	SB5	78790	24.1
3	Impact Bar Bolt Kit incl. (1) ea 5/8" carriage bolt, square washer, flat washer, lock washer, Nylock nut	IBBK	76928	0.5
4	Impact Bar Support -H 4' incl. (1) bar support, (2) ea carriage bolt, square washer, lock washer, Nylock nut	IBS-H4	76933	16.6
4a	Impact Bar Support -H 5' incl. (1) bar support, (2) ea carriage bolt, square washer, lock washer, Nylock nut	IBS-H5	76934	21.0
5	Sliding Support Arm Bolt Kit incl. (2) 2" bolts, (2) lock washers, (2) Nylock nuts	ISABK-LMH	77529	2.0
6	Isolation Mount Kit	IMK	76936	3.8
7	DRX1500 Shim Kit (incl. 8 shims)	SHIM-KITH	77550	27.2

Lead time: 1 working day

Impact Bed Size	Cema C or D 5" (125mm) IDLERS	CEMA C or D 6" (150mm) IDLERS
DRX1500: 24" - 36" (600-900mm)	Shim idler up 1/2" (13mm)	No Kits Required
DRX1500: 42" - 72" (1050-1800mm)	No Kits Required	Use (1) SHIM-KITH; Shim up 1/2" (13mm)

Impact Bed Size	CEMA E 6" (150mm) IDLERS	CEMA E 7" (175mm) IDLERS
DRX1500: 36"-60" (900-1500mm)	Use (3) SHIM-KITH; Shim up 1.5" (38mm)	Use (4) SHIM-KITH; Shim up 2" (50mm)
DRX1500: 72" (1800mm)	Use (4) SHIM-KITH; Shim up 2" (50mm)	Use (5) SHIM-KITH; Shim up 2.5" (63mm)

Replacement Bars and Bolt Kits Required per Belt Width - DRX1500

in.	24	30	36	42	48	54	60	72
mm	600	750	900	1050	1200	1350	1500	1800
Slider Bars Required	2	2	2	2	2	2	2	4
Impact Bars Required	4	4	5	7	8	10	11	12
Impact Bar Supports Required	4	4	5	7	8	10	11	12
Impact Bar Bolt Kits Required	32	32	38	50	56	68	74	88

Section 9 - Replacement Parts

9.4 Optional Replacement Parts

Impact Bars with 1" (25mm) UHMW

For impact beds that have heavy abrasive wear on the impact bars.

DESCRIPTION	ORDERING NUMBER	ITEM CODE	WT. LBS.
4' (1.2M) Impact Bar with 1" (25mm) UHMW	IB4-1U	76965	17.0
5' (1.5M) Impact Bar with 1" (50mm) UHMW	IB5-1U	76966	21.2

Lead time: 1 working day

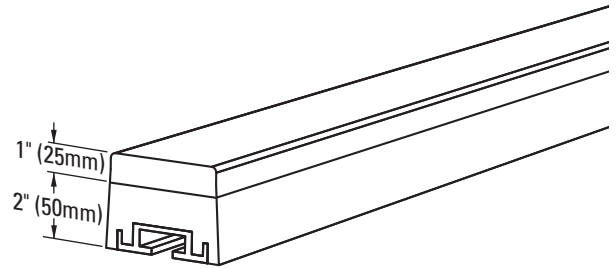

Impact Bar with 1" (25mm) UHMW Cover

Impact Bar Bolt Kit for Other OEM Impact Beds*

1/2" carriage bolt, square washer, flat washer and Nylock nut to mount DRX™ Impact Bars on other OEM beds that use 1/2" T-bolts.

Count cross stringers on OEM bed (example: 3 cross stringers require 3 Bolt Kits per impact bar)

DESCRIPTION	ORDERING NUMBER	ITEM CODE	WT. LBS.
OEM™ Impact Bar Bolt Kit	OIBBK	76950	0.5

*Kit includes 1 ea. bolt, square washer, flat washer and Nylock nut.

Lead time: 1 working day

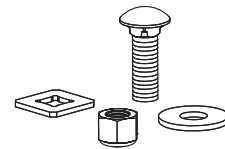

Optional Impact Bar Bolt Kit

Section 10 – Other Flexco Conveyor Products

Flexco provides many conveyor products that help your conveyors to run more efficiently and safely. These components solve typical conveyor problems and improve productivity. Here is a quick overview on just a few of them:

EZP1 Precleaner



- Patented ConShear™ blade renews its cleaning edge as it wears
- Visual Tension Check™ for optimal blade tensioning and simple retensioning
- Quick and easy one-pin blade replacement Material Path Option™ for optimal cleaning and reduced maintenance

Flex-Lok™ Skirt Clamps

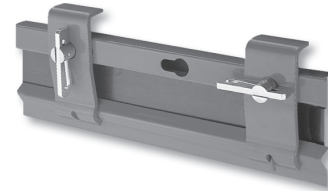

- Eliminates transfer zone spillage
- Interlocking design for easy installation and one person maintenance
- Unique wedge pin holds rubber securely in place and is easy to adjust
- Available in various models and in stainless steel

EZS2 Secondary Cleaner



- Long-wearing tungsten carbide blades for superior cleaning efficiency
- Patented FormFlex™ cushions independently tension each blade to the belt for consistent, constant cleaning power
- Easy to install, simple to service
- Works with Flexco mechanical belt splices

PT Max™ Belt Trainer



- Patented “pivot & tilt” design for superior training action
- Dual sensor rollers on each side to minimize belt damage
- Pivot point guaranteed not to seize or freeze up
- Available for topside and return side belts

Flexco Specialty Belt Cleaners



- “Limited space” cleaners for tight conveyor applications
- High Temp cleaners for severe, high heat applications
- A rubber fingered cleaner for chevron and raised rib belts
- Multiple cleaner styles in stainless steel for corrosive applications

Belt Plows



- A belt cleaner for the tail pulley
- Exclusive blade design quickly spirals debris off the belt
- Economical and easy to service
- Available in vee or diagonal models

Visit www.flexco.com for other Flexco locations and products, or to find an authorized distributor.

©2021 Flexible Steel Lacing Company. 03-20-24. X1932

