

PT Max™ Return Side Data Sheet

CUSTOMER INFO:

Company Name: _____

Address: _____ Date: _____

_____ Phone #: _____

Contact Name: _____ Fax #: _____

Title/Position: _____ e-Mail: _____

Conveyor Name: _____ PO #: _____

Trainer Location: _____ Distributor: _____

INSTRUCTIONS:

1. Tick the relevant conveyor structure type and add dimensions in allocated boxes below.
2. Fill in specs in section 2 on the next page.
3. For unique or unusual mounting or surroundings, attach digital images or sketches. When conveyor is structural angle/channel/tee, sketch the orientation of the structure for mounting.
4. Check One: Mild Steel Stainless Steel
5. Email to PTMaxOrders@flexco.com

1. Examples of Structure Cross Sections

Tick the relevant conveyor structure type and add dimensions in allocated boxes.

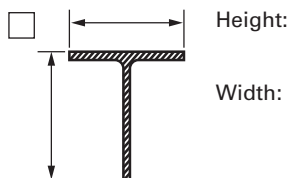
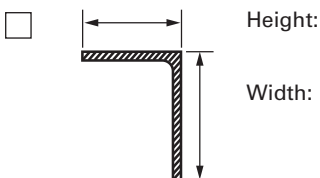
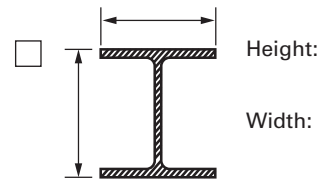
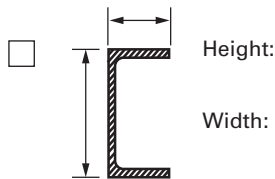
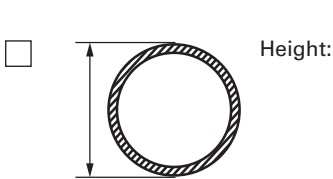

See next page for chart for minimum clearance needed from top of roller to bottom of PT Max.



Top of Roller to Bottom of PT Max Minimum Clearance Needed

ROLL DIAMETER		TOPSIDE						RETURN SIDE						V-RETURN					
		Standard		Heavy-Duty		Super-Duty		Standard		Heavy-Duty		Super-Duty		Standard		Heavy-Duty		Super-Duty	
mm	in.	mm	in.	mm	in.	mm	in.	mm	in.	mm	in.	mm	in.	mm	in.	mm	in.	mm	in.
127	5	406	16	432	17	570	22.25	432	17	457	18	580	22.75	406	16	432	17	570	22.25
152	6	432	17	457	18	590	23.25	457	18	483	19	600	23.75	432	17	457	18	590	23.25
178	7	457	18	483	19	620	24.25	483	19	508	20	630	24.75	457	18	483	19	620	24.25

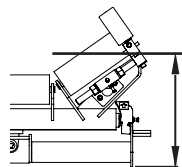

Topside Clearance

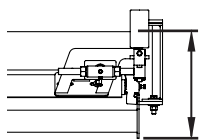

Return Side Clearance

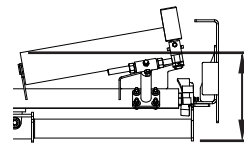

V-Return Clearance

2. Conveyor Structure Dimensions

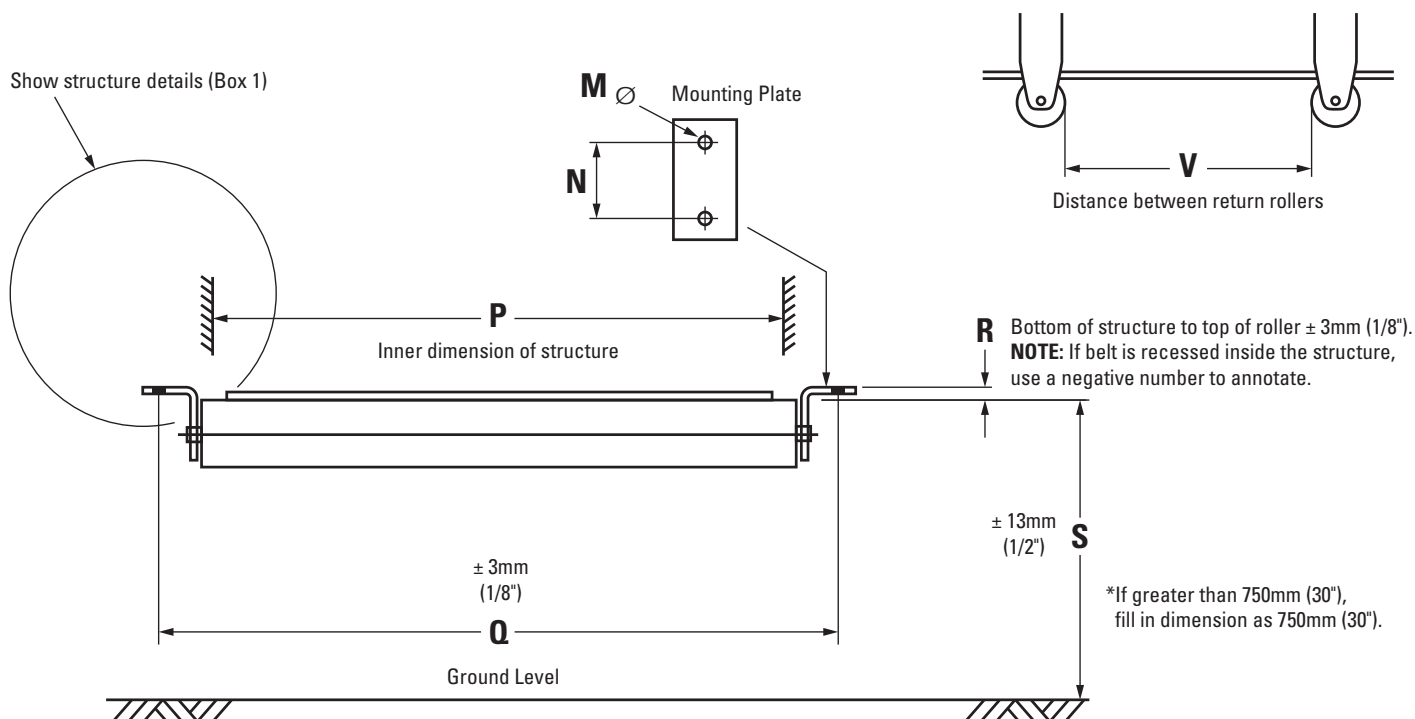

M		R	
N		S	
P		V	
Q			

PT Max™ Roller Data Sheet

CUSTOMER INFO:

Company Name: _____

Address: _____ Date: _____

_____ Phone #: _____

Contact Name: _____ Fax #: _____

Title/Position: _____ e-Mail: _____

Conveyor Name: _____ PO #: _____

Trainer Location: _____ Distributor: _____

INSTRUCTIONS:

- 1.** Fill in conveyor information in section 1 below.
- 2.** Tick the relevant idler cap type in allocated boxes below in section 2.
- 3.** Fill in roller dimensions specs in section 3 on the next page.
- 4.** For unique or unusual mounting or surroundings, attach digital images or sketches.
When conveyor is structural angle/channel/tee, sketch the orientation of the structure for mounting.
- 5.** Email to PTMaxOrders@flexco.com

1. Conveyor Information

Conveyor Name		Return Roller Angle	
CEMA Rating (if known)		Material Carried	
Belt Thickness		Number of Rolls in Troughing Set	
Belt Width		Equal/Unequal Trough Rolls (if unequal, do this sheet for each size)	
Troughing Angle		Roller Brand/Part Number	

2. Idler Cap Type

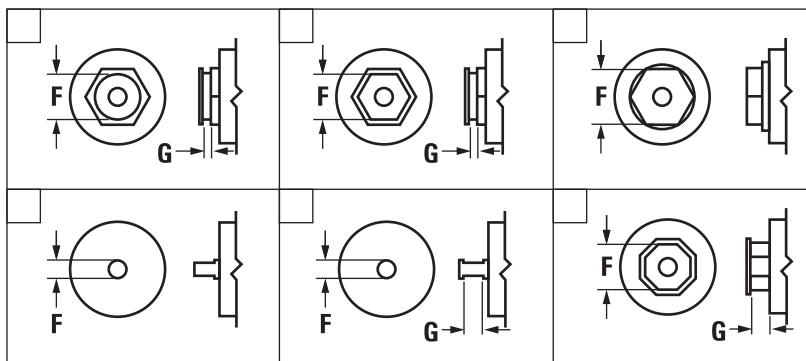

See next page for chart for minimum clearance needed from top of roller to bottom of PT Max.



