

# MANUAL ROLLER LACER®

## PARTS LIST FOR SERIAL NUMBERS 60,000+

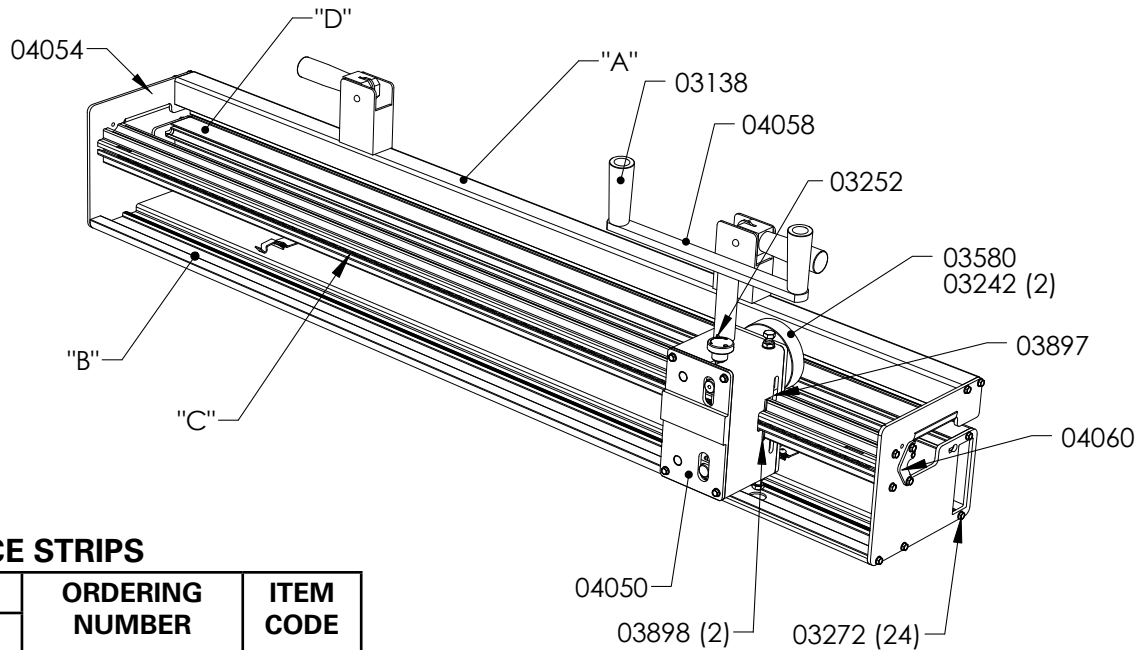

### CLIPPER® FACE STRIPS

BELT WIDTH		ORDERING NUMBER	ITEM CODE
in.	mm		
<b>HOOK SIZE 36, UCM 36</b>			
24	600	FSMAN36-24	04020
36	900	FSMAN36-36	04021
48	1200	FSMAN36-48	04022
60	1500	FSMAN36-60	04023
<b>HOOK SIZE 1, UX-1</b>			
24	600	FSMAN1-24	04015
36	900	FSMAN1-36	04016
48	1200	FSMAN1-48	04017
60	1500	FSMAN1-60	04018
<b>HOOK SIZE 2-4, US2P-U3</b>			
24	600	FSMAN2-24	04025
36	900	FSMAN2-36	04026
48	1200	FSMAN2-48	04027
60	1500	FSMAN2-60	04028
<b>HOOK SIZE 4-1/2-7, U4-U7</b>			
24	600	FSMAN4-1/2-24	04030
36	900	FSMAN4-1/2-36	04031
48	1200	FSMAN4-1/2-48	04032
60	1500	FSMAN4-1/2-60	04033

- 04054 Manual Roller Lacer End Plate
- 03252 Spring Pin 3/16x1 Black Oxide
- 04050 Head Assembly, Manual
- 03898 Stabilizing Wear Insert
- 03272 Screws
- 04060 Face Strip Retaining Latch Kit
- 03897 Guide Block Kit Serial Number 50,000+  
(Incl. 2 Guide Blocks and 2 Stabilizing Wear Inserts)
- 03242 Nylock Nuts
- 03580 Roller Replacement Kit (incl. 2 Roller Assy's)
- 03138 Plastic Drive Knob Assembly
- 04058 Drive Handle Kit Serial Number 60,000+

R.L.	"A"	"B"	"C"	"D"
ASSEMBLY NO.	CLAMP ASSY	BODY PAN	CHAIN ASSY	SLOTTED BELT TUBE
03370	03970	03965	03380	03989
03371	03971	03966	03381	03990
03372	03972	03967	03382	03991
03375	03973	03968	03383	03992
04055	03974	03969	04056	03993



2525 Wisconsin Avenue • Downers Grove, IL 60515-4200 • USA  
Tel: (630) 971-0150 • Fax: (630) 971-1180 • E-mail: info@flexco.com

Visit [www.flexco.com](http://www.flexco.com) for other Flexco locations and products.

