

Converting the Manual Roller Lacer[®] to accept the 3-Layer Face Strip

(Serial Numbers 3500 - 59999)



It is recommended that you follow these steps when converting lacers with serial numbers 3500-59999 if you will be using the 3-layer face strip exclusively. If both the 3-layer and 2-layer face strips will be used, you may use the 3-layer Face Strip with the Locking Lever(s) and Backup Bar Assembly in place but not engaged. Both of the Face Strip Retaining Latches will need to be installed.

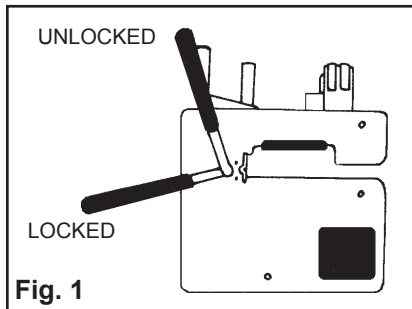

Fig. 1
1. Make sure Locking Levers are in the unlocked/upright position.

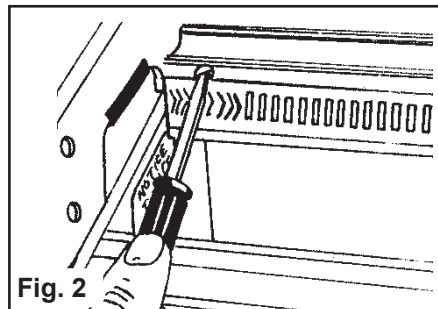

Fig. 2
2. Remove the 2-layer Face Strip by first loosening the thumb screw or slotted style screw and then sliding the Face Strip out through either end of the lacer.

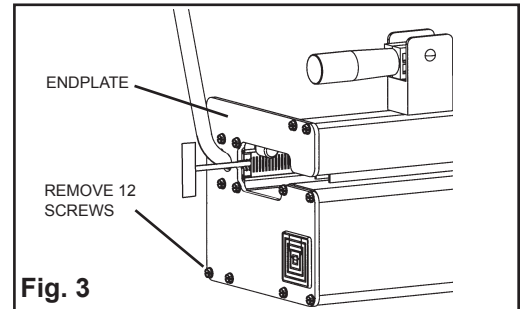

Fig. 3
3. Remove the first End Plates by starting at one end of the lacer and removing the 12 self-tapping machine screws that secure the End Plate to the extruded components of the Roller Lacer. The 24" Roller Lacer and the Microlacer only have one Locking Lever. Remove the End Plate from this side. A gentle pull or slight tap with a hammer may be needed to free the End Plate from the spring pin stop for the Locking Lever.

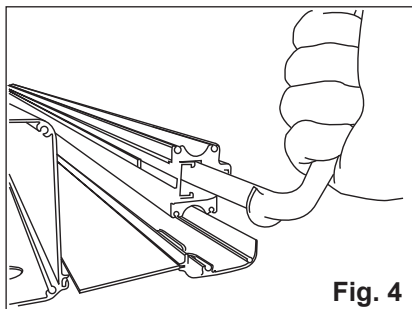

Fig. 4
4. Remove and discard the Locking Lever Assembly.

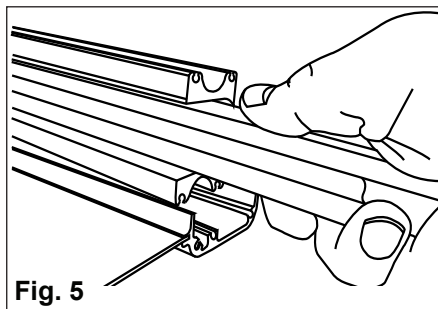

Fig. 5
5. Remove and discard the Backup Bar Assembly located in the Extruded Body.

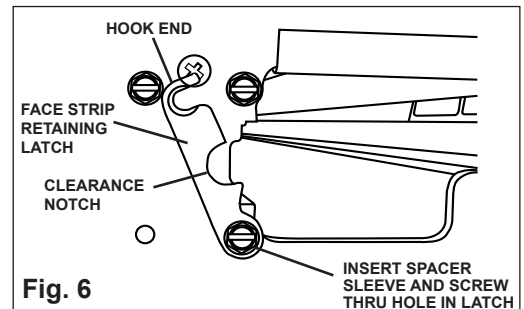
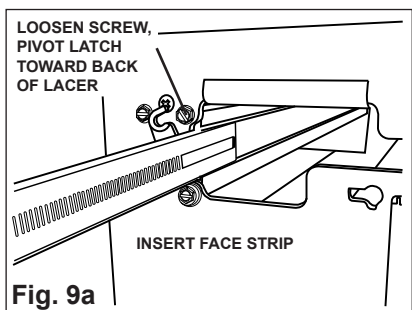

Fig. 6
6. Locate the two Face Strip Retaining Latches included with the Face Strip Kit.

7. Reattach the End Plate. Be sure not to over-torque the self-tapping machine screws when tightening.

- a. Install one of the Face Strip Retaining Latches so that the Lacer Pin clearance notch faces towards the Face Strip. The hook end of the Face Strip Retaining Latch should be located at the top. Insert spacer sleeve and screw through hole in other end of latch. See Fig. 6.
- b. Tighten the screws making sure not to over-torque them.

8. For 36", 48" and 60" Roller Lacers repeat Steps 3 through 8 for opposite side.



- Fig. 9a**
9. Install the new 3-Layer Face Strip into the Extruded Body.
- a. Loosen the top screw securing the Face Strip Retaining Latch and pivot the latch towards the back of the lacer. See Fig. 9a.
 - b. Insert the Face Strip all the way into the Extruded Body.
 - c. Pivot the Face Strip Retaining Latch back into position. See Fig. 9b.
 - d. Tighten the top screw.

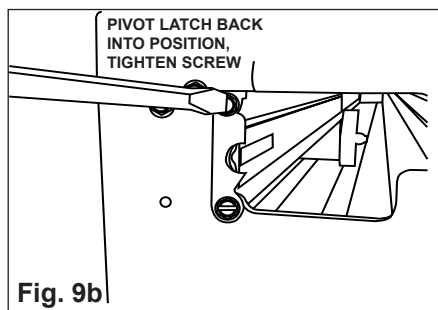

- Fig. 9b**

