

Replacement Parts List

Flex-Lifter™
Conveyor Belt Lifter

Replacement Parts

REF	DESCRIPTION	ORDERING NUMBER	ITEM CODE	WT. LBS.
1a	Extension Leg - Medium	FLEL-M	76472	3.1
1b	Extension Leg - Large	FLEL-L	76473	3.7
1c	Extension Leg Kit- XL (includes 2 ext. legs)	FLELK-XL	76986	13.0
2	Extension Leg Pin (with lanyard)	FLELP	76474	0.1
3a	Trough Wing - Medium (with brace)	FLTW-M	76476	1.2
3b	Trough Wing - Large (with brace)	FLTW-L	76477	1.5
3c	Trough Wing - XL (with brace)	FLTW-XL	76985	4.2
4	Retainer Pin Pack (includes 4 pins)	FLRP	76478	1.0
5	Retainer Clip Pack (includes 4 clips)	FLCP	76479	0.1
6a	Return Lift Bar - Medium	FLRLB-M	76482	25.0
6b	Return Lift Bar - Large	FLRLB-L	76481	50.0
6c	V-Return Lift Bar - XL	FLVRL-XL	76984	63.0
7a	Shear Pin Kits - Medium/Large	FL-PKIT-ML	77250	0.3
7b	Shear Pin Kits - XL	FL-PKIT-XL	77251	0.5

Lifts troughed or flat belts
Lead time: 1 working day

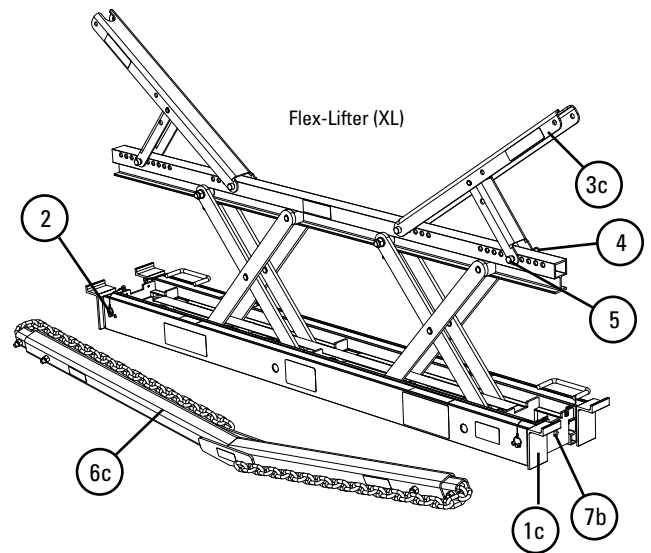
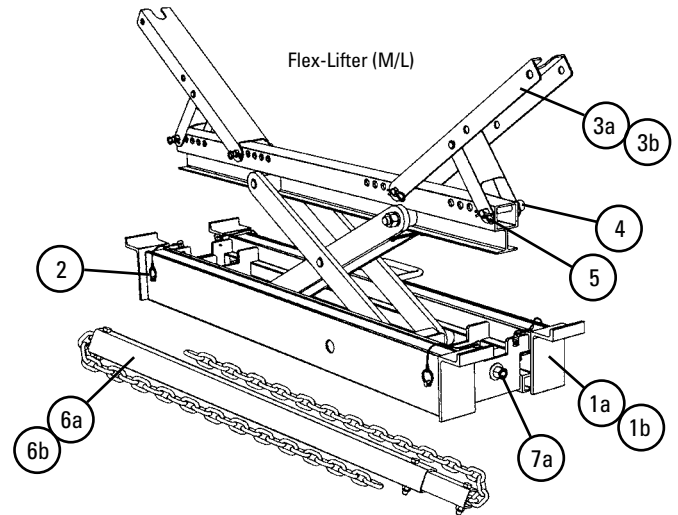

2525 Wisconsin Avenue • Downers Grove, IL 60515-4200 • USA
Tel: (630) 971-0150 • Fax: (630) 971-1180 • E-mail: info@flexco.com

Visit www.flexco.com for other Flexco locations and products.

©2019 Flexible Steel Lacing Company. 01/15/19. For reorder: X1450

