

# RMC1/RMC1-LS Skirt Clamps

## Instructions for Installation

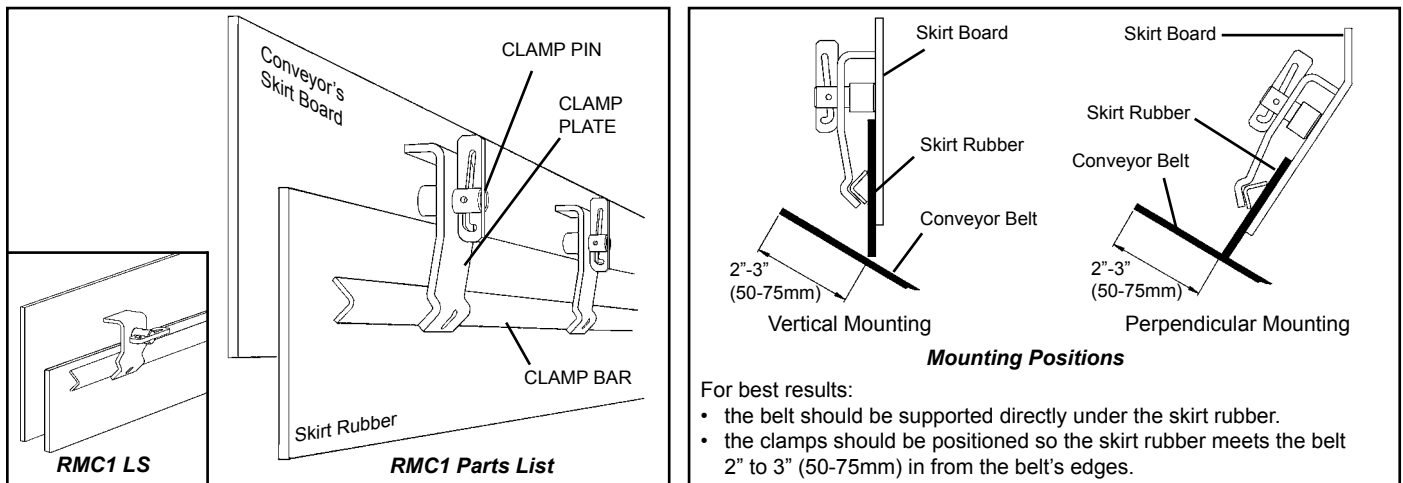

**PHYSICALLY LOCK OUT AND TAG THE CONVEYOR AT THE POWER SOURCE BEFORE YOU BEGIN SKIRT CLAMP INSTALLATION.**

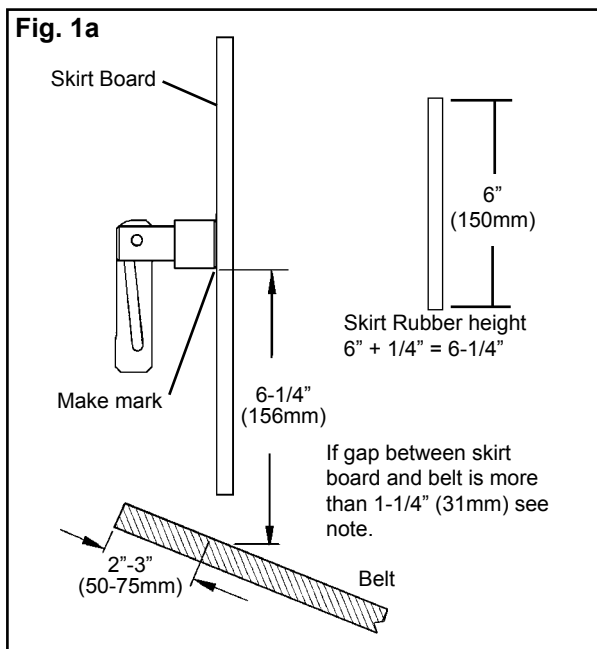

- Determine the correct position for the clamp pins on the skirt board.** Measure the height of the skirt rubber and add 1/4" (6mm). Using this dimension measure from the belt's surface up the skirt board and make a mark (Fig. 1a). Repeat this several times down the skirt board and draw a line connecting the marks (Fig. 1b).

**NOTE:** If the gap between the skirt board and the belt is greater than 1-1/4" (31mm), hold a clamp plate up on the clamp pin to be sure the clamp bar will have the backing of the skirt board to clamp the skirt rubber against. If not, adjust the line for mounting the clamp pins upward accordingly.

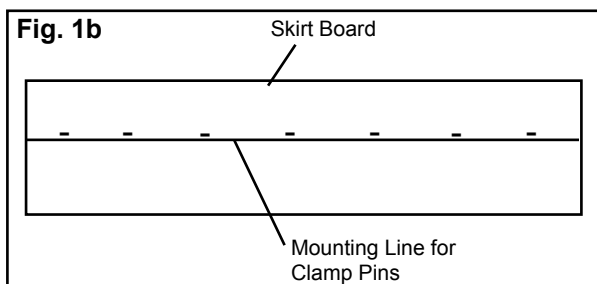

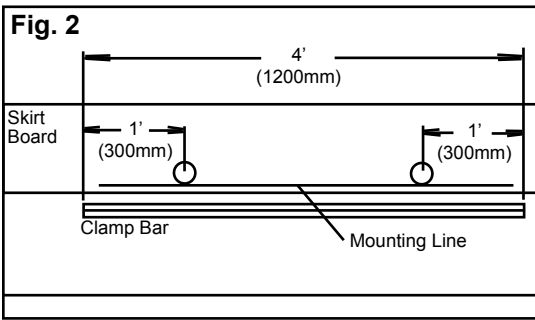

2. **Select the spots to weld the two clamp pins.** The optimum position for each clamp pin is 1' (300mm) in from each end of the 4' (1200mm) clamp bar (Fig. 2). If an obstruction prevents this positioning, move that clamp pin as needed. **NOTE: Determine the best direction the wedge in the clamp pin should be in for easy access. Once the pin is welded to the skirt board the wedge direction is fixed.**

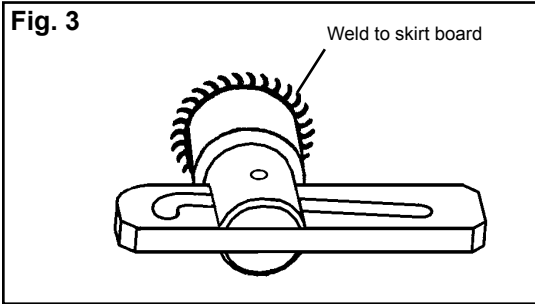

3. **Weld the clamp pins.** Clean the surface of the skirt board around the areas where the pins will be welded. Weld the base of the pin securely since this is the main support for the skirt clamp (Fig. 3). A 1/4" weld all the way around is recommended.

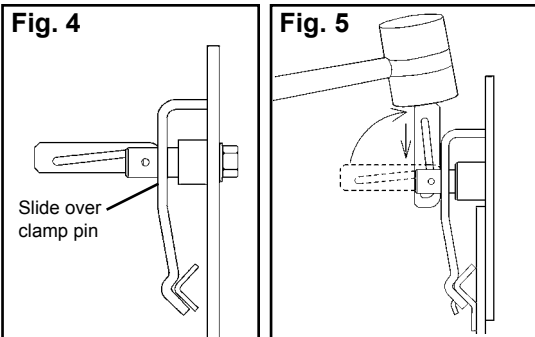

4. **Assemble the clamp plates and the clamp bar.** Slide the clamp plates over the clamp pins and mount the clamp bar under the plates (Fig. 4).

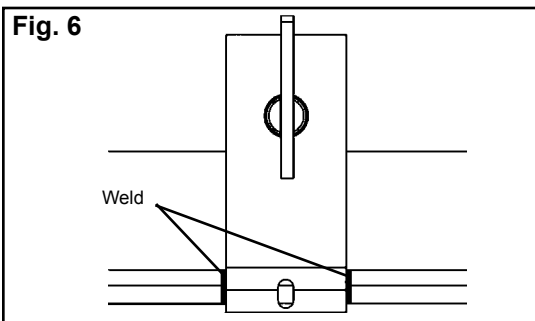

5. **Position the skirt rubber (not included) between the clamp bar and the skirt board.** The skirt rubber should be positioned to the top of the belt. When in place, lock the clamps by hammering the wedges on the clamp pins tight (Fig. 5). **NOTE: A 1-lb. hammer is recommended.**
6. **Fasten the clamp plates and the clamp bar together.** Tack weld the clamp plates and the clamp bar together (Fig. 6). This will make it easy to do future adjustment of the skirt rubber.

