

PT Max™ V-Return Side Data Sheet

CUSTOMER INFO:

Company Name: _____

Address: _____ Date: _____

_____ Phone #: _____

Contact Name: _____ Fax #: _____

Title/Position: _____ e-Mail: _____

Conveyor Name: _____ PO #: _____

Trainer Location: _____ Distributor: _____

INSTRUCTIONS:

1. Check the relevant conveyor structure type and add dimensions in allocated boxes below.
2. Circle the conveyor structure type and add dimensions in section 2 below.
3. Check One: Mild Steel Stainless Steel
4. Fill in specs in section 3 below.
5. For unique or unusual mounting or surroundings, attach digital images or sketches. When conveyor is structural angle/channel/tee, sketch the orientation of the structure for mounting.
6. Email to PTMaxOrders@flexco.com

1. Troughing Set Type

V-Return _____ ° Troughing Angle

2. Examples of Structure Cross Sections

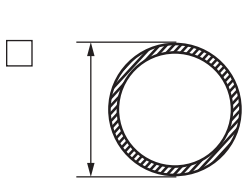

Height:

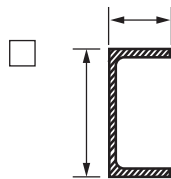

Height:

Width:

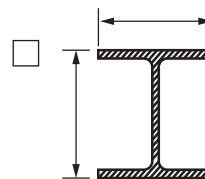

Height:

Width:

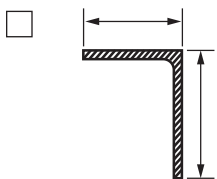

Height:

Width:

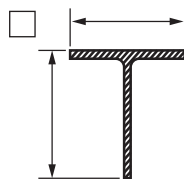

Height:

Width:

See next page for chart for minimum clearance needed from top of roller to bottom of PT Max.



Top of Roller to Bottom of PT Max Minimum Clearance Needed

ROLL DIAMETER		TOPSIDE						RETURN SIDE						V-RETURN					
		Standard		Heavy-Duty		Super-Duty		Standard		Heavy-Duty		Super-Duty		Standard		Heavy-Duty		Super-Duty	
in.	mm	in.	mm	in.	mm	in.	mm	in.	mm	in.	mm	in.	mm	in.	mm	in.	mm	in.	mm
5	127	16	406	17	432	22.25	570	17	432	18	457	22.75	580	16	406	17	432	22.25	570
6	152	17	432	18	457	23.25	590	18	457	19	483	23.75	600	17	432	18	457	23.25	590
7	178	18	457	19	483	24.25	620	19	483	20	508	24.75	630	18	457	19	483	24.25	620

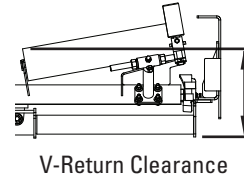
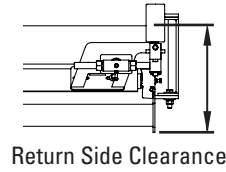
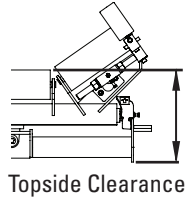

3. Conveyor Structure Dimensions

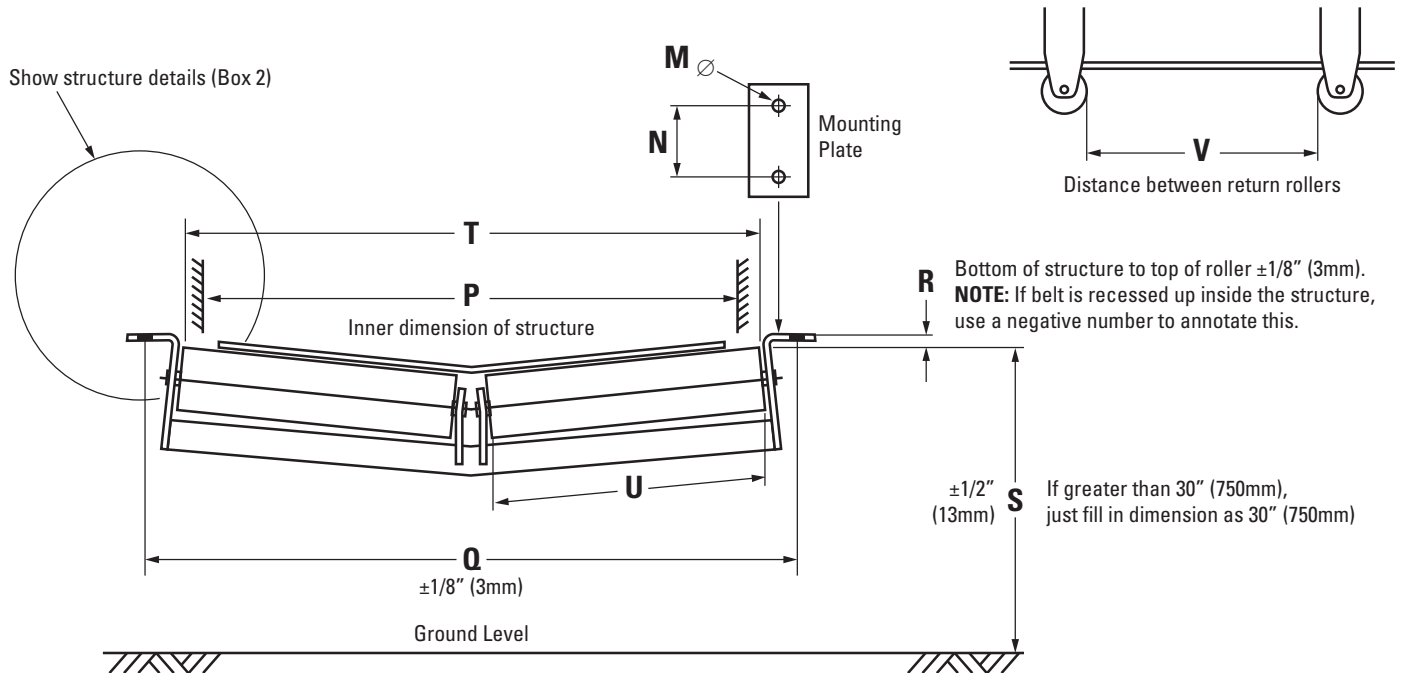

M		S	
N		T	
P		U	
Q		V	
R			

Questions? Contact Ryan Holowaty at (616) 242-1724 or email rhollowaty@flexco.com

 2525 Wisconsin Avenue • Downers Grove, IL 60515-4200 • USA
Tel: (630) 971-0150 • Fax: (630) 971-1180 • E-mail: info@flexco.com

Visit www.flexco.com for other Flexco locations and products.

©2018 Flexible Steel Lacing Company, 09/13/21. For reorder: X1155

