

PT Max™ Top Side Data Sheet

CUSTOMER INFO:

Company Name: _____

Address: _____ Date: _____

_____ Phone #: _____

Contact Name: _____ Fax #: _____

Title/Position: _____ e-Mail: _____

Conveyor Name: _____ PO #: _____

Trainer Location: _____ Distributor: _____

INSTRUCTIONS:

1. Check troughing set type and indicate troughing angle in section 1 below. If you're measuring a location under skirting, the PT Max will not work. You need to move further down the conveyor away from the skirting and take measurements there.
 2. Check the relevant conveyor structure type and add dimensions in allocated boxes below.
 3. Check One: Mild Steel Stainless Steel
 4. Fill in specs in section 3 on the next page.
 5. For unique or unusual mounting or surroundings, attach digital images or sketches. When conveyor is structural angle/channel/tee, sketch the orientation of the structure for mounting.
 6. Email to: PTMaxOrders@flexco.com
-

1. Troughing Set Type

Inline Roller Offset Roller _____ ° Troughing Angle Under Skirting

2. Examples of Structure Cross Sections

Check the relevant conveyor structure type and add dimensions in allocated boxes.

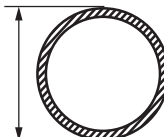
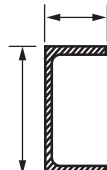
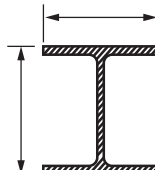
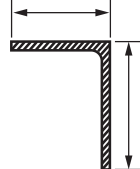
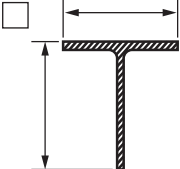
<input type="checkbox"/>  Height: _____	<input type="checkbox"/>  Height: _____ Width: _____	<input type="checkbox"/>  Height: _____ Width: _____
<input type="checkbox"/>  Height: _____ Width: _____	<input type="checkbox"/>  Height: _____ Width: _____	

See next page for chart for minimum clearance needed from top of roller to bottom of PT Max.



Top of Roller to Bottom of PT Max Minimum Clearance Needed

ROLL DIAMETER		TOPSIDE						RETURN SIDE						V-RETURN					
		Standard		Heavy-Duty		Super-Duty		Standard		Heavy-Duty		Super-Duty		Standard		Heavy-Duty		Super-Duty	
in.	mm	in.	mm	in.	mm	in.	mm	in.	mm	in.	mm	in.	mm	in.	mm	in.	mm	in.	mm
5	127	16	406	17	432	22.25	570	17	432	18	457	22.75	580	16	406	17	432	22.25	570
6	152	17	432	18	457	23.25	590	18	457	19	483	23.75	600	17	432	18	457	23.25	590
7	178	18	457	19	483	24.25	620	19	483	20	508	24.75	630	18	457	19	483	24.25	620

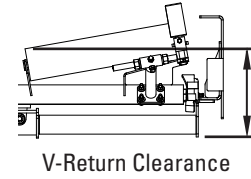
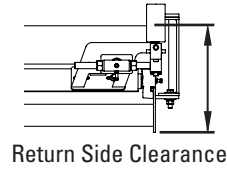
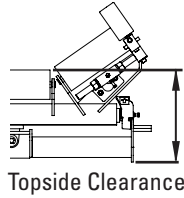

3. Conveyor Structure Dimensions

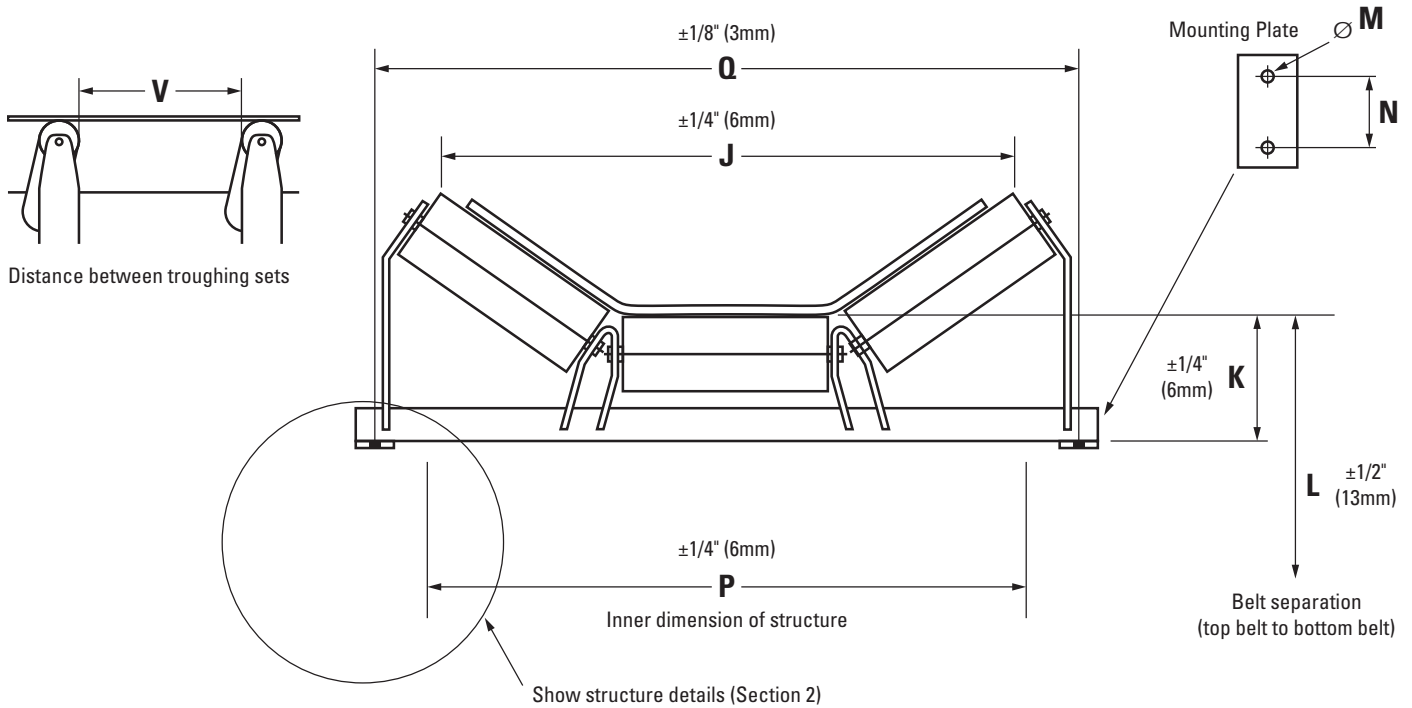

J		N	
K		P	
L		Q	
M		V	

Questions? Contact Ryan Holowaty at (616) 242-1724 or email rholowaty@flexco.com



PT Max™ Roller Data Sheet

CUSTOMER INFO:

Company Name: _____

Address: _____ Date: _____

_____ Phone #: _____

Contact Name: _____ Fax #: _____

Title/Position: _____ e-Mail: _____

Conveyor Name: _____ PO #: _____

Trainer Location: _____ Distributor: _____

INSTRUCTIONS:

- 1.** Fill in conveyor information in section 1 below.
- 2.** Check the relevant idler cap type in allocated boxes below in section 2.
- 3.** Fill in roller dimensions specs in section 3 on the next page.
- 4.** For unique or unusual mounting or surroundings, attach digital images or sketches.
When conveyor is structural angle/channel/tee, sketch the orientation of the structure for mounting.
- 5.** Email to PTMaxOrders@flexco.com

1. Conveyor Information

Conveyor Name		Return Roller Angle	
CEMA Rating (if known)		Material Carried	
Belt Thickness		Number of Rolls in Troughing Set	
Belt Width		Equal/Unequal Trough Rolls (if unequal, do this sheet for each size)	
Troughing Angle		Roller Brand/Part Number	

2. Idler Cap Type

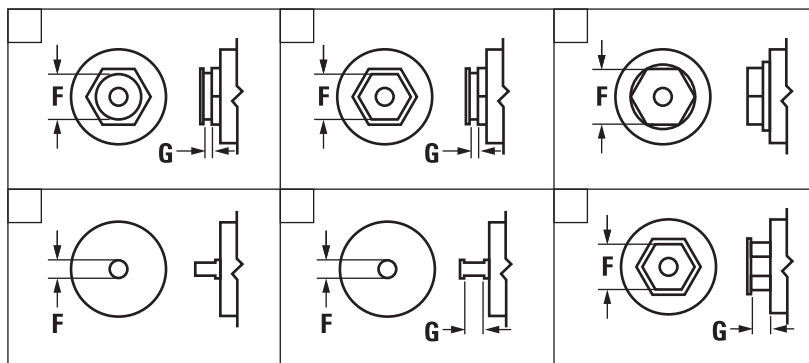

See next page for chart for minimum clearance needed from top of roller to bottom of PT Max.



3. Roller Dimensions

Roller dimensions are easily measured from a spare roller not installed in the conveyor system.

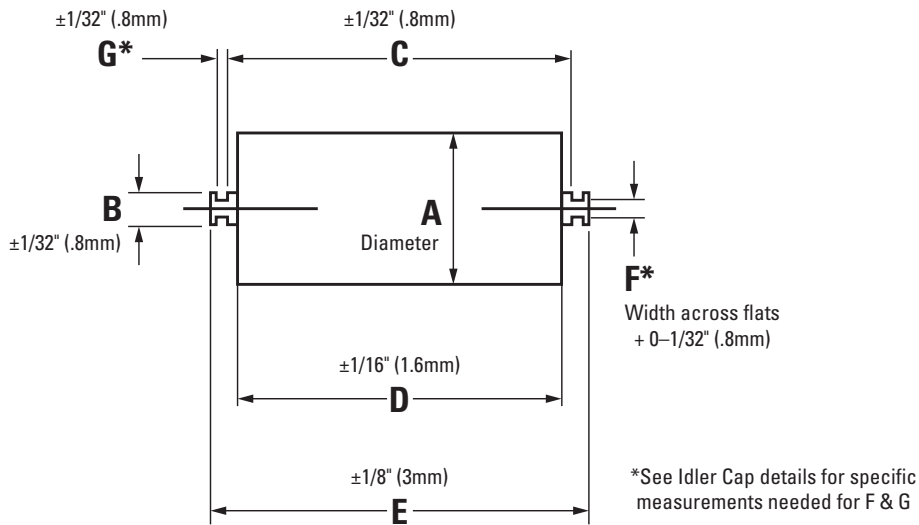

A		E	
B		F	
C		G	
D			

Top of Roller to Bottom of PT Max Minimum Clearance Needed

ROLL DIAMETER		TOPSIDE						RETURN SIDE						V-RETURN					
		Standard		Heavy-Duty		Super-Duty		Standard		Heavy-Duty		Super-Duty		Standard		Heavy-Duty		Super-Duty	
in.	mm	in.	mm	in.	mm	in.	mm	in.	mm	in.	mm	in.	mm	in.	mm	in.	mm	in.	mm
5	127	16	406	17	432	22.25	570	17	432	18	457	22.75	580	16	406	17	432	22.25	570
6	152	17	432	18	457	23.25	590	18	457	19	483	23.75	600	17	432	18	457	23.25	590
7	178	18	457	19	483	24.25	620	19	483	20	508	24.75	630	18	457	19	483	24.25	620

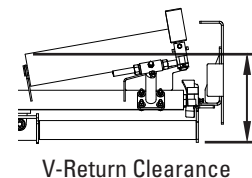
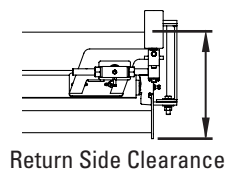
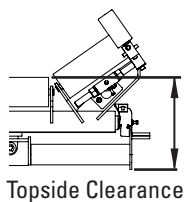

Questions? Contact Ryan Holowaty at (616) 242-1724 or email rholowaty@flexco.com

Visit www.flexco.com for other Flexco locations and products, or to find an authorized distributor.

©2018 Flexible Steel Lacing Company, 09-05-24, X1074

