

# Flex-Lok™ Skirt Clamps (Standard and Mini Flex-Lok) Instructions for Installation

## Standard Kit Includes:

- (1) Clamp Runner
- (1) Restraining Bar
- (4) Clamp Plates
- (4) Clamp Pins

## Mini Kit Includes:

- (1) Clamp Runner
- (1) Restraining Bar
- (3) Mini Clamp Plates
- (3) Clamp Pins

### Tools Needed:

- Tape Measure
- Wire Brush
- Welder
- Marker
- Rubber or Non-metal Hammer

## Before You Begin:

- **Physically lock out and tag the conveyor at the power source.**
- Remove any existing clamp attachments from the skirt board.
- Clean the skirt board surface for welding.
- Wear safety goggles and follow all safety precautions when welding.
- For best results the skirt clamp must be positioned so the skirt material meets the belt 2" - 3" (50 - 75mm) in from the belt edge.
- The skirt material must not be folded in so that it lies on top of the belt. Such an installation may cause the skirt material to be pulled out of the clamp.
- For mounting positions see back page.

## INSTALLATION

### Step 1. Determine the correct height to position the clamp runner.

Take the height of the skirt material being used and add 1/4". Using that dimension, measure from the belt surface up the skirt board and make a mark. Repeat this measurement several times down the skirt board the length of the skirt clamp. The bottom of the clamp runner will be aligned on these marks. **NOTE:** If the gap between the skirt board and the belt is more than 1-1/4", check to be sure that the restraining bar will be against the skirt board when assembled. The restraining bar must have the skirt board to push against to provide the clamping action on the skirt material. If part of the restraining bar is off the skirt board, move the marks up accordingly.

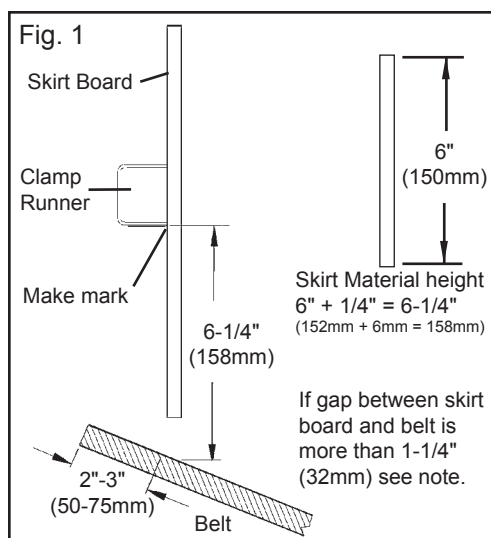
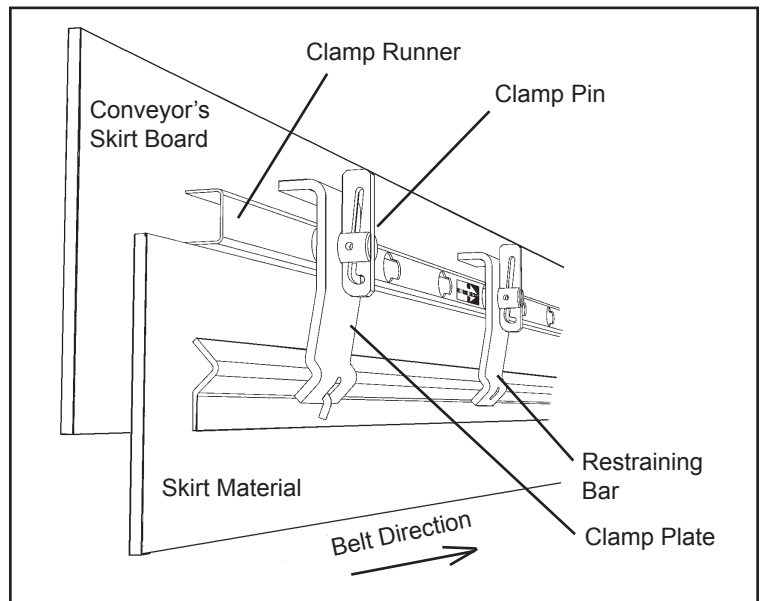

### Step 2. Position the clamp runner on the skirt board.

**Important:** The clamp runner must be aligned so the small ends of the keyholes point in the direction of belt travel (Fig. 2). **Note:** See label on clamp runner.

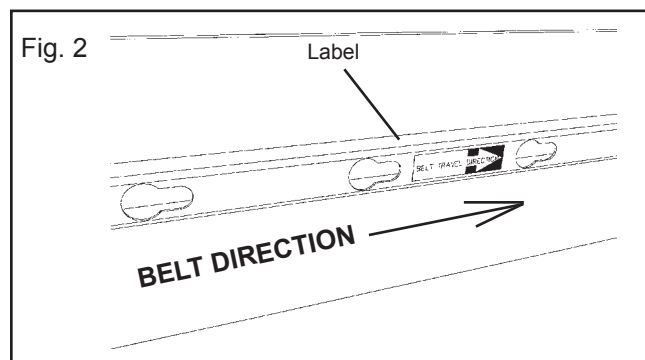

### Step 3. Weld the clamp runner.

Stitch weld both sides with 1/4" (6mm) weld, 2" (50mm) long, in 6 places (Fig. 3).

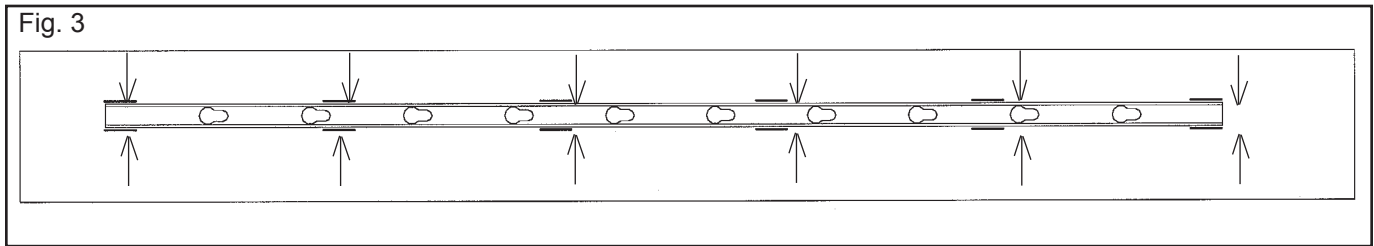

### Step 4. Insert four clamp pins into the clamp runner.

Install one in each end slot and space the other two as required (one in center for Mini Flex-Lok).

**Important:** Clamp pins must be locked into the small end of the keyhole slot (Fig. 4).

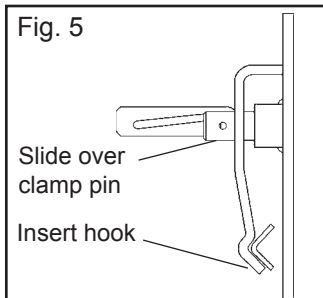
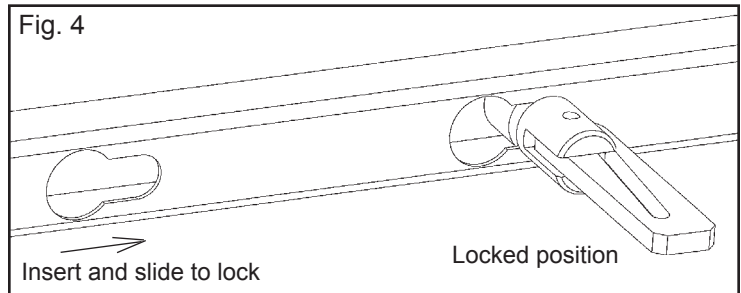

### Step 5. Mount clamp plates and the restraining bar.

Slide clamp plates over the clamp pins on each end and mount restraining bar by inserting hooks into holes in the clamp plates (Fig. 5). Install center two clamp plates over clamp pins.

### Step 6. Position skirt material (not included) between the restraining bar and the skirt board.

- The skirt material should be positioned to the top of the belt.
- Position and lock wedges on the clamp pins into place with a rubber or non-metal hammer (Fig. 6).

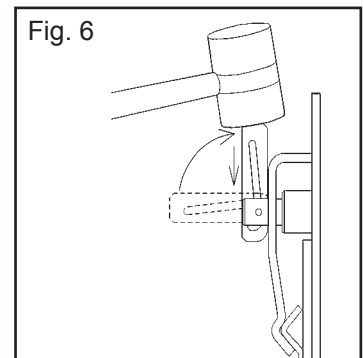

## MOUNTING POSITIONS

For best results the conveyor belt should be supported directly under the skirt material.

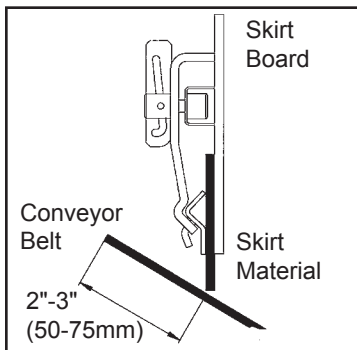

**Vertical Mounting**

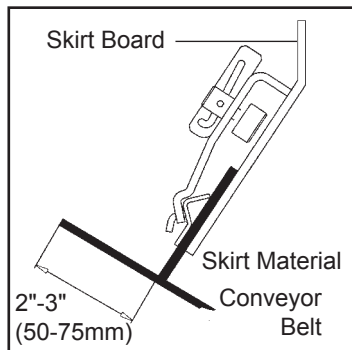

**Perpendicular Mounting**

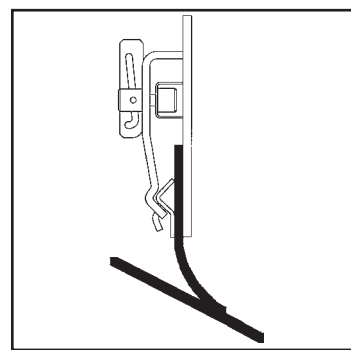

**Incorrect Mounting**