

Alligator® Plastic Rivet Fastener Spin-Set™ Installation Tool

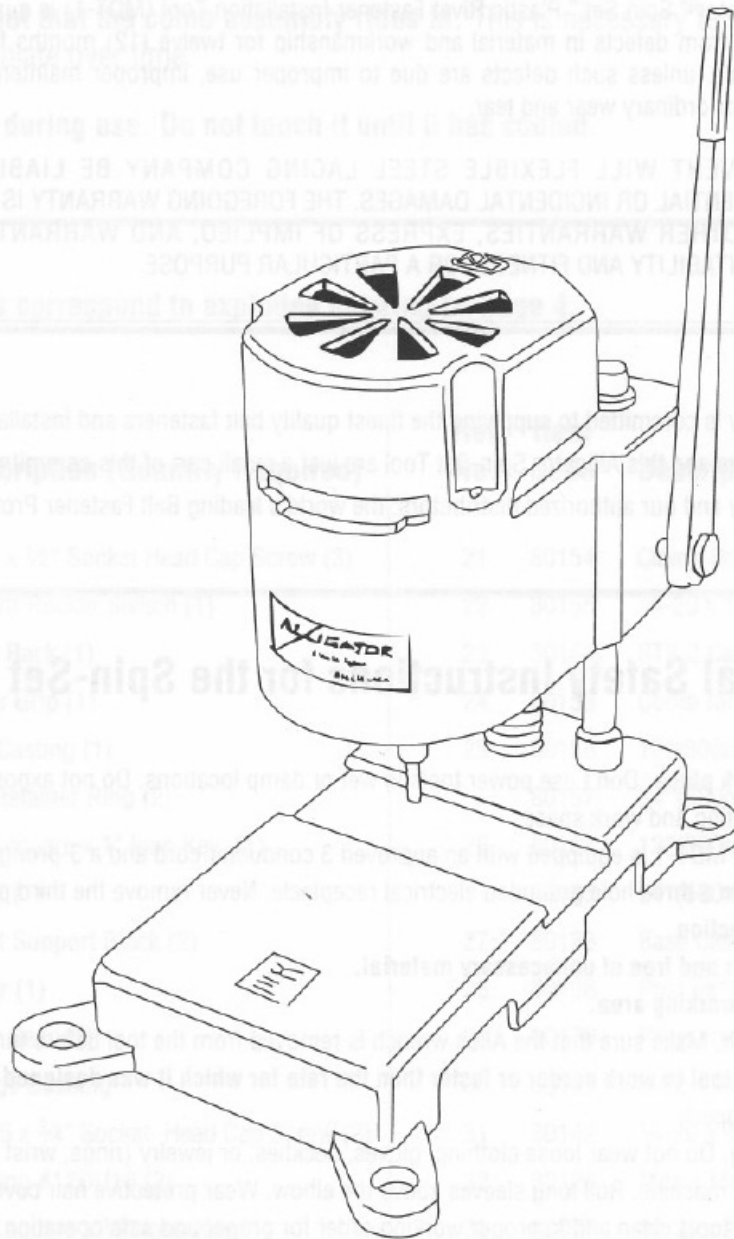

Alligator® Plastic Rivet Fastener Spin-Set™

Thank you and congratulations on the purchase of your Alligator® Spin-Set™ Installation Tool. This tool is the finest of its type in the world and is compatible only with Alligator Plastic Rivet Fasteners. Lightweight for portability in the field or shop and durable for long and trouble free service, the Alligator Spin-Set tool complements the entire line of Alligator and Gator® brand fasteners. Furthermore, your Alligator Spin-Set Tool carries a written warranty.

WARRANTY

Your Alligator® Spin Set™ Plastic Rivet Fastener Installation Tool (MDT-1) is guaranteed to be free from defects in material and workmanship for twelve (12) months from the time of sale, unless such defects are due to improper use, improper maintenance or handling, or ordinary wear and tear.

IN NO EVENT WILL FLEXIBLE STEEL LACING COMPANY BE LIABLE FOR CONSEQUENTIAL OR INCIDENTAL DAMAGES. THE FOREGOING WARRANTY IS IN LIEU OF ANY OTHER WARRANTIES, EXPRESS OF IMPLIED, AND WARRANTIES OF MERCHANTABILITY AND FITNESS FOR A PARTICULAR PURPOSE.

Flexible Steel Lacing Company is committed to supplying the finest quality belt fasteners and installation tools in the world. Alligator Plastic Rivet Fasteners and this Alligator Spin-Set Tool are just a small part of this commitment and are backed by Flexible Steel Lacing Company and our authorized distributors: the world's leading Belt Fastener Professionals.

General Safety Instructions for the Spin-Set Tool.

1. **Avoid dangerous work place.** Don't use power tools in wet or damp locations. Do not expose power tools to rain. Provide adequate lighting and work space.
2. **Ground all tools.** The MDT-1 is equipped with an approved 3 conductor cord and a 3-prong grounding type plug. It should be plugged into a three hole grounded electrical receptacle. Never remove the third prong.
3. **Always use eye protection.**
4. **Keep work area clean and free of unnecessary material.**
5. **Keep hands clear of working area.**
6. **Remove Allen wrench.** Make sure that the Allen wrench is removed from the tool before turning it on.
7. **Don't try to force the tool to work harder or faster than the rate for which it was designed.** It will do the job safer and better when used properly.
8. **Wear proper clothing.** Do not wear loose clothing, gloves, neckties, or jewelry (rings, wrist watches, bracelets) that may get caught in the machine. Roll long sleeves above the elbow. Wear protective hair covering to contain long hair.
9. **Maintain tools.** Keep tools clean and in proper working order for proper and safe operation.
10. **Avoid accidental starting.** Make sure that the power switch is in the **OFF** position before plugging the unit in.
11. **Check for damaged parts.** Before using the tool, make sure that there are no broken parts. Repair or replace them before using the tool.
12. **Never leave a tool running unattended.** Turn the power off when finished using the tool. Don't leave until the Curling Bit comes to a complete stop. Unplug the tool when not in use.

Alligator® Plastic Rivet Fastener Spin-Set™

Installing the lever on the Spin-Set™ tool:

1. All required parts including an Allen wrench are included with the tool. They include the MDT-1, one lever, one key, one washer, and one Allen screw. If anything is missing, report it to your authorized Alligator® distributor.
2. Insert the key into the keyway on the shaft protruding from the right side of the tool.
3. Slide the lever over the shaft and the key. If necessary, tap the lever lightly with a hammer to set it in place.
4. Place the washer over the shaft and insert the Allen screw through the washer and into the threaded hole in the shaft. Tighten the screw with the Allen wrench (provided) until snug. **Do not over tighten.**

Periodically clean the slot that the comb assembly rides in. This is necessary to remove any build up of material that may accumulate over time.

The Curling Bit gets hot during use. Do not touch it until it has cooled.

Parts list - numbers correspond to exploded drawing on page 4.

Ref. No.	Item Code	Description (Quantity Required)	Ref. No.	Item Code	Description (Quantity Required)
1.	80143	6-32 x 1/2" Socket Head Cap Screw (3)	21.	80154	Clamp Stud for Comb Assembly (*)
2.	80178	On-Off Rocker Switch (1)	22.	80155	1/4-20 x 1" Flat Head Socket Cap Screw (**)
3.	80129	Gear Rack (1)	23.	50188	ST3-3 Cam Lever Spring (**)
4.	80177	Lever Grip (1)	24.	80153	Comb for Comb Assembly (*)
5.	80127	Cap Casting (1)	25.	80156	12"(300mm) Bed (1)
6.	80132	3/4" Retainer Ring (2)		80157	24"(600mm) Bed (1)
7.	80182	3/16" square x 1" long Key (1)	26.	80164	12"(300mm) Gauge Pin (1)
8.	80131	Shaft (1)		80165	24"(600mm) Gauge Pin (1)
9.	80133	Shaft Support Block (2)	27.	80126	Base Casting (1)
10.	80138	Lever (1)	28.	80136	Post 3/4" diameter (2)
11.	80130	Spur Gear (1)	29.	80179	Pressure Die Spring (1)
12.	80137	Flange Bushing	30.	80141	8-32 x 3/4" Socket Head Cap Screw (4)
13.	80139	3/8-16 x 3/4" Socket Head Cap Screw (2)	31.	80142	1/4-20 x 3/4" Socket Head Cap Screw (1)
14.	80180	Bearing #12DU16 (2)	32.	80128	Motor Mount Casting (1)
15.	80181	3/16" square x 1/2" long Key (1)	33.	80077	10-32 x 3/16" Socket Head Set Screw (1)
16.	80176	Lever Cap (1)	34.	80146	Cord Set (1)
17.	80140	1/4-20 x 3/4" Flat Head Socket Cap Screw (1)	35.	80134	Strain Relief Bushing (1)
18.	80150	Clamp Knob for Comb Assembly (*)	36.	80145	Motor Assembly (1)
19.	80152	Washer for Comb Assembly (*)	37.	80076	S150B Curling Bit (includes Curling Bit, Set Screw (#33) and Allen Key).
20.	80151	Clamp Bar for Comb Assembly (*)			

(*)12" Comb Assembly requires 2; 24" Comb Assembly requires 4.

(**)12" Comb Assembly requires 4; 24" Comb Assembly requires 8.

Alligator® Plastic Rivet Fastener Spin-Set™

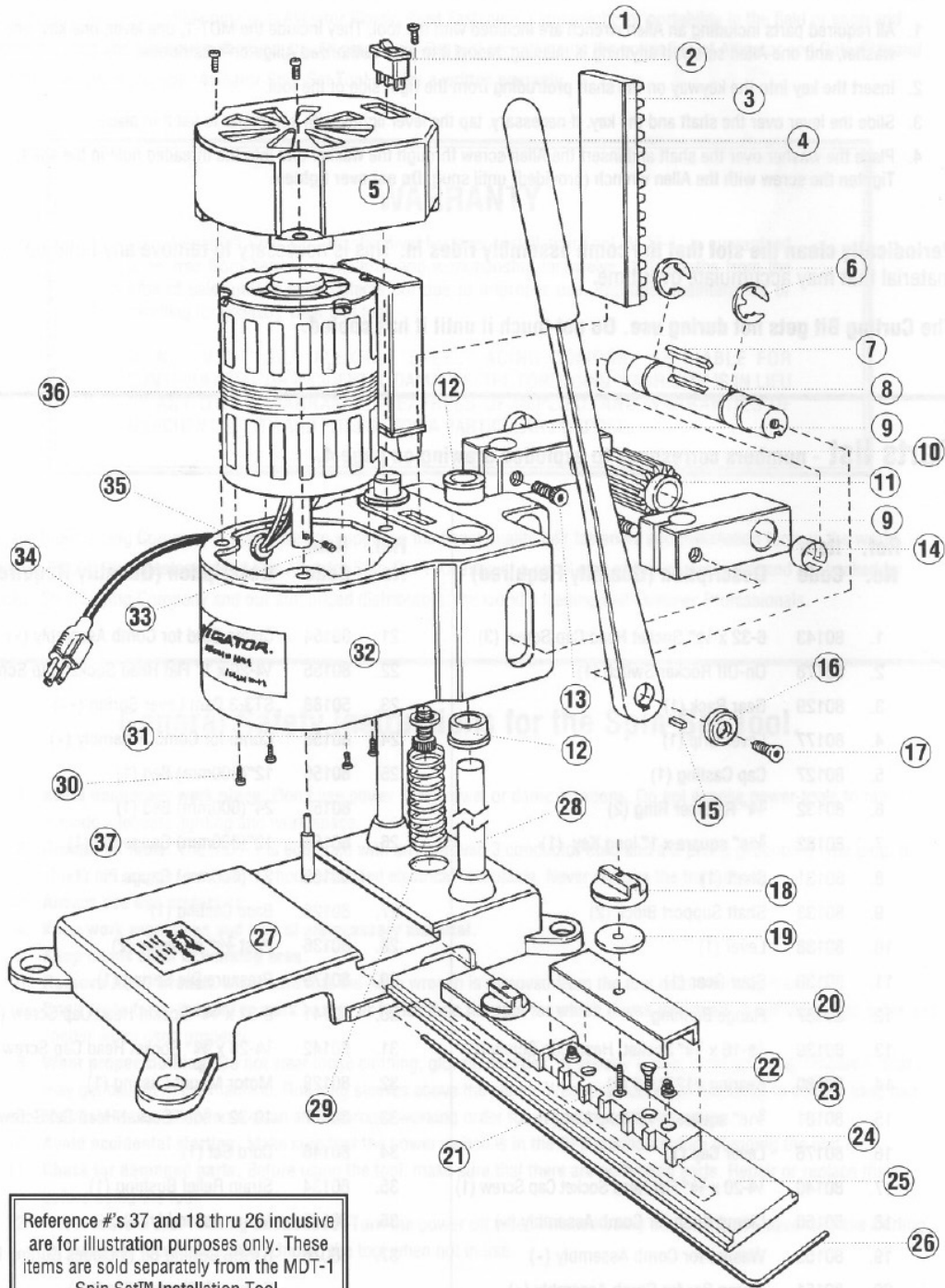

Visit www.flexco.com for other Flexco locations and products, or to find an authorized distributor.

©2014 Flexible Steel Lacing Company. Flexco® is a registered trademark. 12-19-23. X0346

