

Wash Box System Spec Sheet

CUSTOMER INFO:

Company Name: _____

Address: _____ Date: _____

Phone #: _____

Contact Name: _____ Fax #: _____

Title/Position: _____ e-Mail: _____

Conveyor Name: _____ PO #: _____

Washbox Location: _____ Distributor: _____

DIMENSIONS

Dim	Description	Value
A	Belt width	
B	Outside stringer width	
C	Total space available on side of stringer	
D	Distance of belt below stringer	
E	Total space available along stringer	
F	Total space available beneath stringer	
	Belt incline to horizontal	
	Material	
	Belt speed	
	Cleaner Type	

Please return completed form to FlexcoFirstTeam@flexco.com.

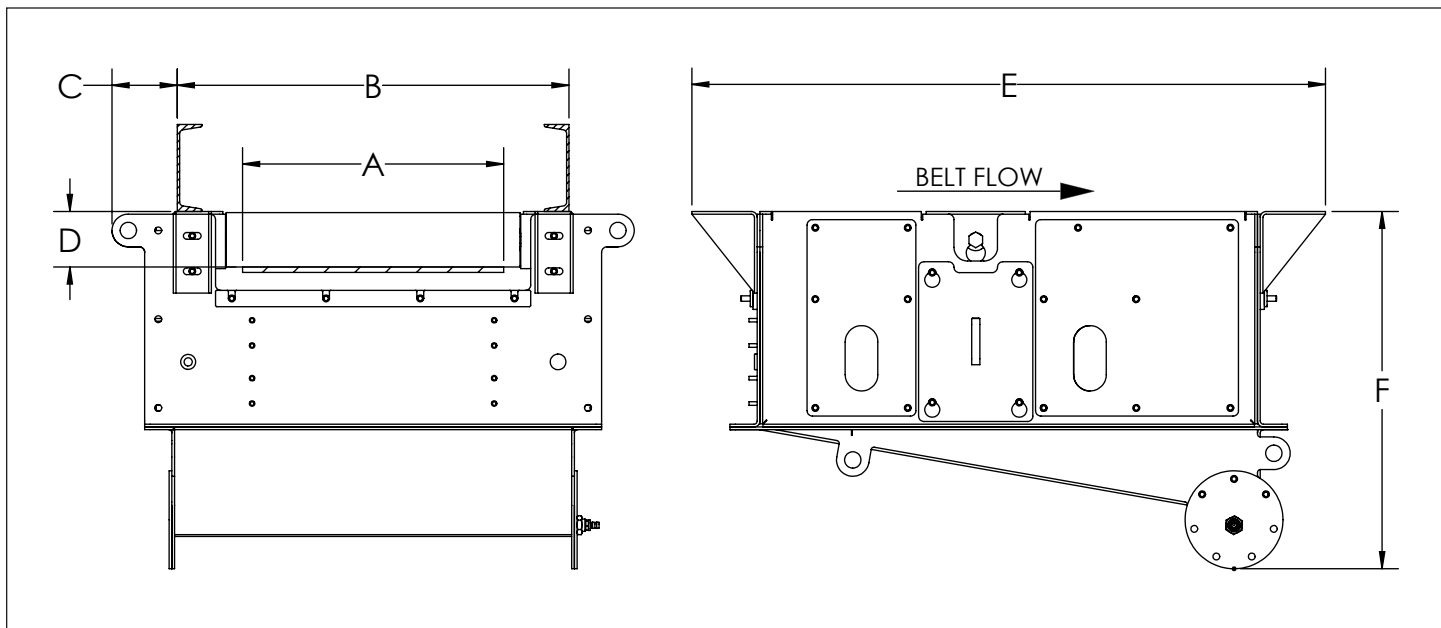

2525 Wisconsin Avenue • Downers Grove, IL 60515-4200 • USA
 Tel: (630) 971-0150 • Fax: (630) 971-1180 • E-mail: info@flexco.com

Visit www.flexco.com for other Flexco locations and products.

©2020 Flexible Steel Lacing Company, 05/06/20. For reorder: W601

