

# Novitool® Aero® Press Stand for 1525, 1835, 2135

## Fabrication Considerations

Seek the consultation of qualified engineering and fabrication resources to accommodate strength and stability requirements prior to starting. The considerations listed below are available to aid in fabrication of an Aero® Press stand.

Stands fabricated must accommodate:

- Max press weight 120 kg (265 lb)
- Max press length 2325 mm (91.5 in)

Top Beam weights	kgs.	lbs.
Aero 1525	43.6	96.2
Aero 1835	50.0	110.2
Aero 2135	56.6	124.8

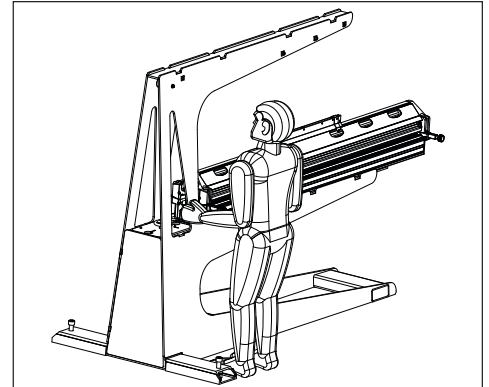

Proper splicing requires full weight of top beam be applied to belt

- Bladders reside in top beam.
- Counterweight systems must off load weight once top beam is landed.

When constructing a stand, the builder must take into consideration:

- Potential lift methods
  - Counterweight
  - Pneumatic
  - Hydraulic
  - Electric linear actuator
  - Crane hoist
- Lift Height—381-457 mm (15-18") target
- Accommodation for moving
  - Fork truck lift point
  - Casters w/landing pads
- Leveling pads

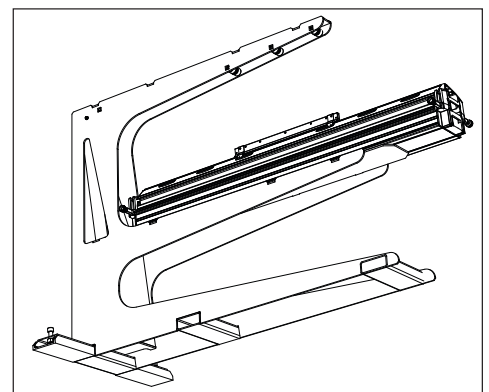

Designing for safety, balance, stand stability, and structural integrity is the responsibility of the end user. The considerations provided are for informational purposes only. The considerations are provided as is without any guarantees or warranty as to the construction of a press stand. In association with the considerations provided, Flexco makes no warranties of any kind, either express or implied, including but not limited to warranties of fitness for a particular purpose. Use of the constructed stand by a user is at the user's risk.

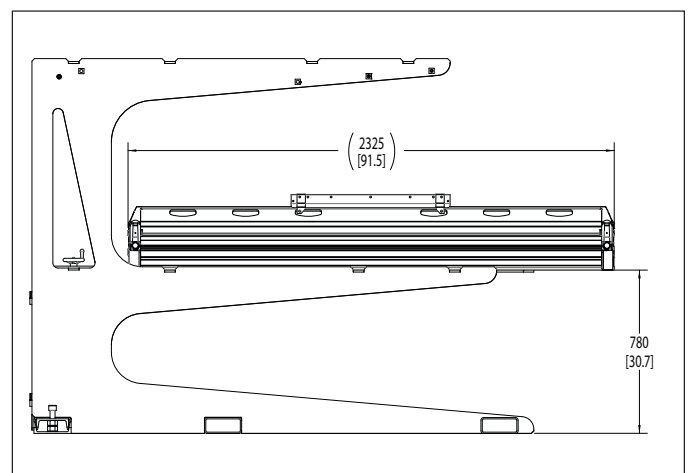

Flexco Europe GmbH • Maybachstrasse 9 • 72348 Rosenfeld • Germany  
 Tel: +49-7428-9406-0 • Fax: +49-7428-9406-260 • E-mail: europe@flexco.com

Visit [www.flexco.com](http://www.flexco.com) for other Flexco locations and products.

©2020 Flexible Steel Lacing Company. 04/08/20. For reorder: W586

