

Extending the Life of Straight Warp Belts

What is a Straight Warp Belt?

If you are working in a demanding application with high-impact, tear resistant belting, there's a good chance you're working with a straight warp belt carcass. Straight warp fabric contains basic tension-bearing warp yarns, combined with interwoven binder cords. Straight warp belts are most commonly used when conveying heavy and/or large materials such as timber, stone, or sand and gravel.

Belt joining challenges

While straight warp belting is useful in these applications, some issues arise when joining the belts together during splicing. Bolt-style fasteners, while fast and cost-effective, can weaken the belt when carcass material is punched out prior to inserting the bolts. This can compromise the strength of the belt.

Another option, vulcanization, is successful at maintaining a strong splice, but is often costly and time consuming. Also, a trained professional is required for the vulcanization process, which is especially inconvenient in an emergency repair situation.

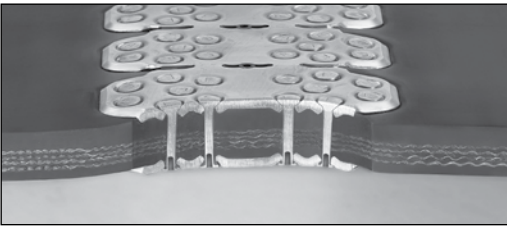

Benefits of the Rivet-Style Fastener

A solution to these belt-joining issues is the rivet-style mechanical fastener. A rivet splice saves both time and money, while maintaining the strength of the belt. Instead of displacing carcass material during installation, staggered, multiple-point rivet attachments pass between carcass fibers, separating them and maintaining the integrity of the belt.

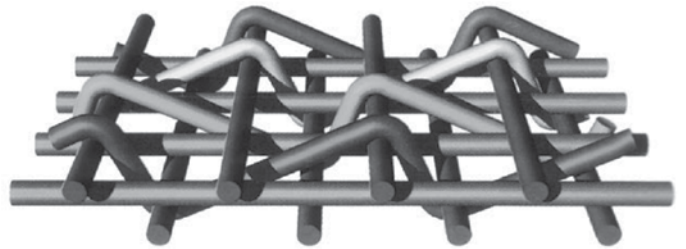

Permission to reprint figure granted by CEMA.

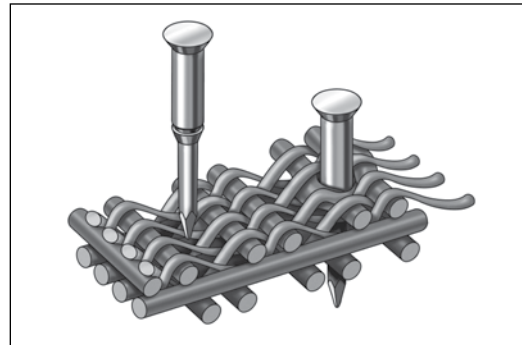

Instead of displacing carcass, rivet style fasteners separate the fibers.

Hinged or Solid Plate?

Rivet fasteners are available in hinged and solid plate varieties. Rivet-hinged fasteners are ideal for use with portable conveyors and on conveyors with smaller pulley diameters. Solid plate fasteners are ideal for heavy duty applications, especially ones that utilize straight warp belting based on their durability and because the solid plates discourage materials from sifting through the splices.

New, smaller-style rivet plate fasteners are now available for those looking for a more cost-effective solution. They offer the same benefits as a larger fastener, including durability and abrasion resistance, and they work on smaller pulley diameters that still require a fastener for higher-tension applications (up to 70 kN/m or 400 P.I.W.).

Metal selection is also important when choosing a fastener to fit your application. While plated steel fits most applications, many fasteners are also available in stainless steel, RustAlloy®, and MegAlloy® for abrasive and corrosive environments, as well as Everdur® for spark-free, non-magnetic performance.

Flexco® Rivet Solid Plate

What to look for in a quality rivet solid plate fastener:

- Compatibility with high-tension applications
- Staggered pattern of self-setting rivets to ensure maximum belt grip
- Broad width and heavy gauge of plates for extended wear life
- Low-profile design to eliminate high spots or edges that might hang up on the belt

Flexco® Rivet Solid Plate Fastener Selection Chart

Fastener Size	For Belts With Mechanical Fastener Ratings Up To:		Belt Thickness Range		Recommended Min. Pulley Diameter					
					Operating Tension 75-100% of Belt Rating		Operating Tension 50-75% of Belt Rating		Operating Tension Under 50% of Belt Rating	
	kN/m	P.I.W.	mm	in.	mm	in.	mm	in.	mm	in.
BR6	70*	400*	6.5-17	1/4-21/32	350	14	mm	in.	mm	in.
BR10	114	650	6-17	7/32-11/16	450	18	400	16	350	14
BR14	140	800	10-24	13/32-15/16	900	36	860	34	860	34

* Contact Flexco Engineering for applications greater than 70kN/m (400 PIW).

Flexco® BR6 Rivet Solid Plate Fastener

Flexco's **BR6 rivet solid plate fastener** is a smaller plate fastener, which makes it ideal for small pulley diameters. It offers the same benefits as a larger fastener, and is more cost-effective.

Designed for fast, simple installation, the BR6 only requires a hammer and portable MBRT tool to align and drive in rivets. Perfect for use in sand, gravel, crushed stone, grain, coal, cement, and salt applications, the BR6 is ideal for belts with mechanical fastener ratings up to 70 kN/m (400 P.I.W.) and thicknesses of 6.5-17 mm (1/4 - 21/32 in.). Available in steel, MegAlloy®, stainless steel, and Everdur®, the BR6 offers a long service life in even the most demanding high-tension applications.



240 Macpherson Road • #02-01 • Singapore 348574
Tel: +65-6484-1533 • Fax: +65-6484-1531 • E-mail: asiasales@flexco.com

Visit www.flexco.com for other Flexco locations and products.

©2010 Flexible Steel Lacing Company. Flexco®, RustAlloy®, MegAlloy®, Everdur®, are registered trademarks. 06-17-19. For Reorder: W369



Partners in Productivity