

Flexco® XP™ SINGLE Blade Belt Skiver Operating Instructions

Ordering Number: XPSK-SB

Item Code: 102099

Wear Proper PPE: Hand, eye, and foot.

Tool Inspection: Examine the tool before each use. Check that blade is not loose. Inspect blade for nicks, cracks, or other damage. Replace blade if not sharp.

Operational Instructions: Clean belt prior to skiving. Make sure belt is flat. Do not skive into carcass. Tool skives top side of belt. Flip belt if necessary to skive opposite side.

WARNING: Keep fingers and hands away from the skiver blade at all times.

Main Components

Flexco® XP™ Single Blade Belt Skiver	
1. Blade Holder	5. Upper Pressure Plate
2. Blade Holder Adjustment Lever	6. Upper Pressure Plate Adjustment Lever
3. Skiver Blade (32074)	7. Lower Belt Support
4. Drive Handle	8. Belt Stops (N0179)

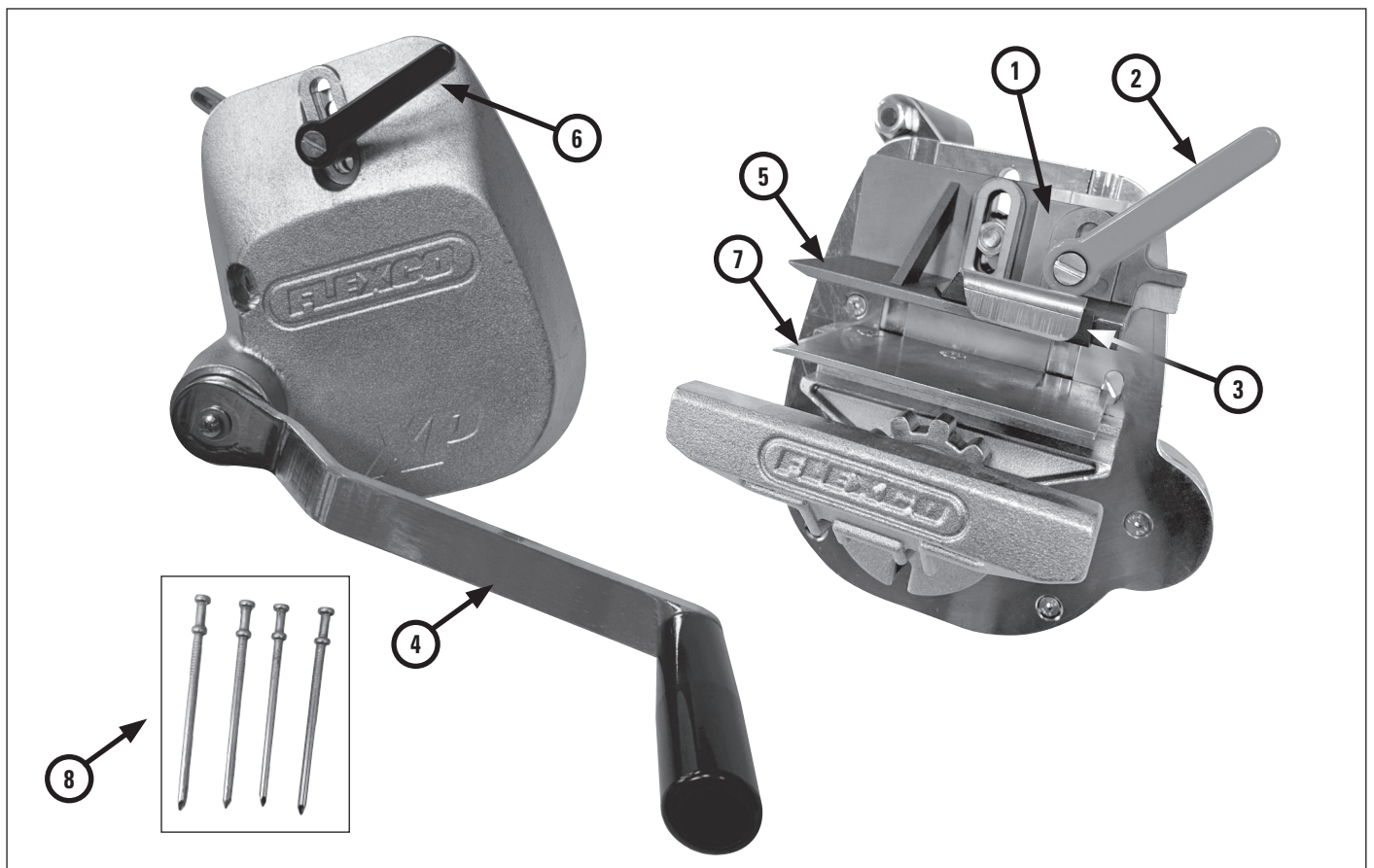

Skiver Belt Specifications

Skive belts up to 50 mm (2") thick. Maximum skive per pass is 10 mm (3/8"). Skive width of XP3/XP5 = 35 mm (1-3/8"). Skive width of XP7/XP8 = 38 mm (1-1/2").

Installation Instructions

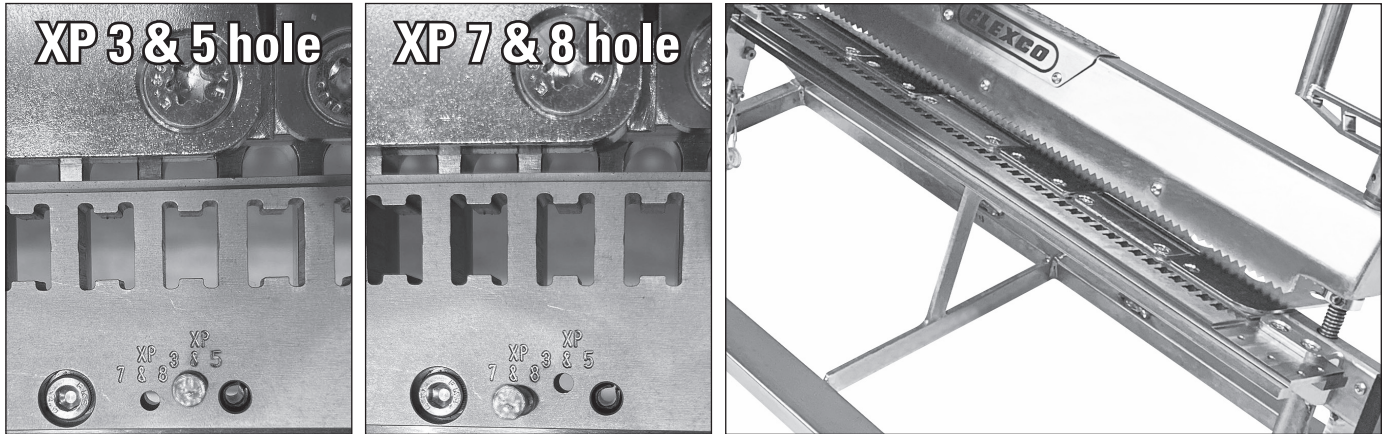

1. Insert belt end into frame centered on the bed and until it rests against all belt stops. Tighten clamp bar.



2. **a.** Attach the skiver to the bed by sliding the mounting bracket onto the left side of bed rail. **b.** Turn Drive Handle clockwise to engage the skiver with the bed. Raise Upper Pressure Plate. Move skiver over belt until Upper Pressure Plate is positioned about 50 mm (2") over the belt. **Ensure blade is not touching the belt.** **c.** Push Upper Pressure Plate firmly down against belt surface and tighten Adjustment Lever to lock in position.

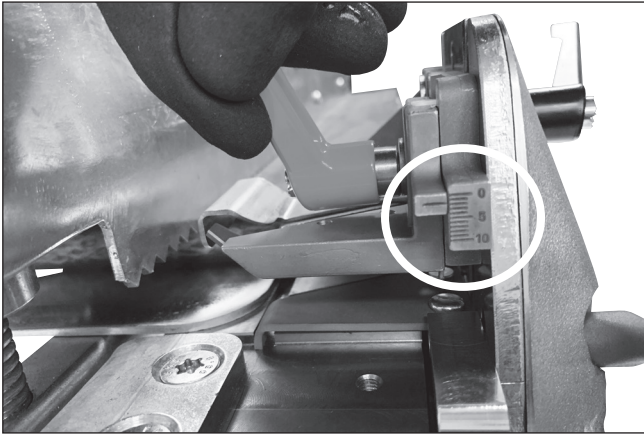

3. Adjust blade holder to desired cutting depth. Ensure blade adjustment handle is in the up position prior to skiving.

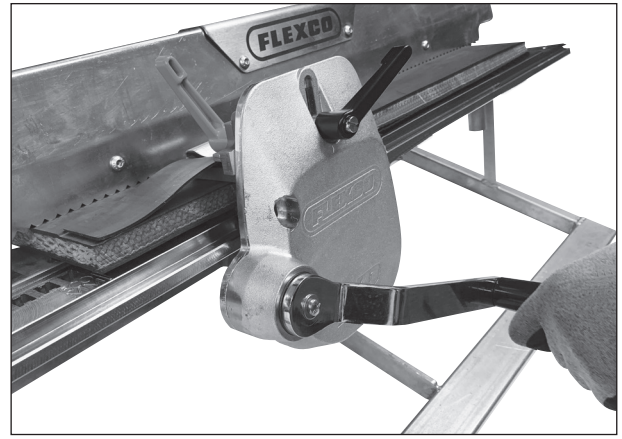

4. Turn Drive Handle clockwise to begin skiving. Make sure scrap cut does not get jammed in skiver. Spraying silicone on belt will reduce required effort. **If effort is high, stop, reverse and inspect for loose or damaged parts.**

5. Remove nails before performing the belt splice.

Changing the Blade

WARNING: Use caution when handling blade. Unscrew the upper pressure plate adjustment lever and remove assembly. Using a slotted screwdriver, remove the two screws from the blade holder. Replace worn blade with new one. Retighten screws. Reattach the upper pressure plate.

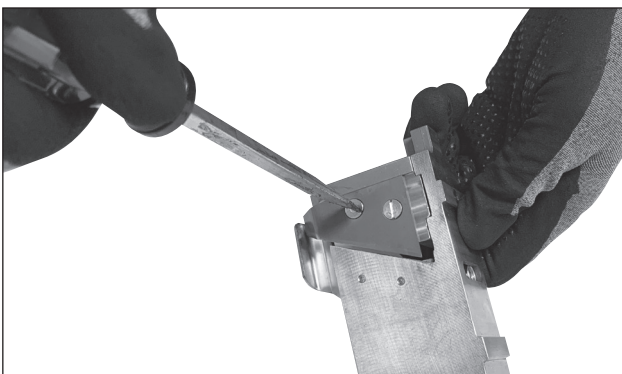
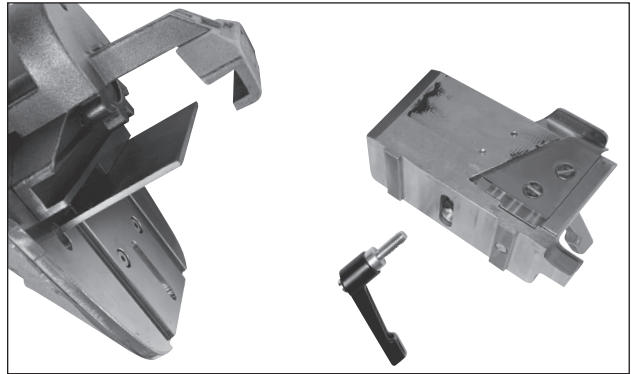
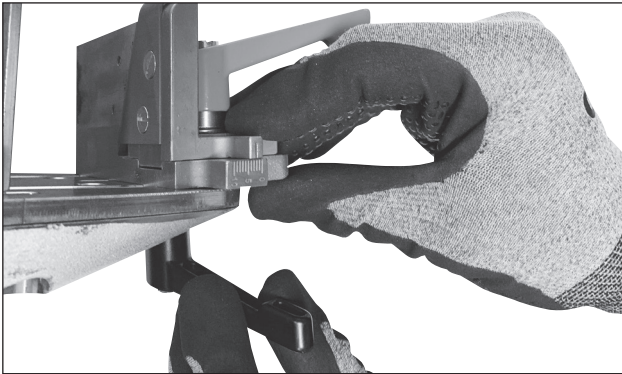

Flexco (Aust.) Pty. Ltd • 10 Solent Circuit, Norwest • NSW, Australia, 2153 • Australia
Tel: 612-8818-2000 • Fax: 612-8824-6333 • E-mail: salesau@flexco.com

Visit www.flexco.com for other Flexco locations and products, or to find an authorised distributor.

©2020 Flexible Steel Lacing Company. 07-15-24. W2028

