

FLEXTREME™ Secondary Cushion

Reliable High-Speed P-Type® Cleaner Cushion

The Flexco® Flextreme™ Secondary Cushion (PXTC) is the ideal cleaner cushion to pair with aggressive high-speed belts. The polyurethane cushion is encased in stainless steel, removing any chance of delamination; resulting in increased longevity.



Features and Benefits

- Suitable for belt speeds up to 7.5 m/s (1475 FPM).
- Designed for use in long shut down cycles where standard cushions will fatigue.
- A complete cleaning system when coupled with a standard P-Type® configuration.
- Compatible with existing P-Type® cleaners.

FLEXTREME™ Secondary Cushion

Specifications and Guidelines

Maximum Belt Speed

7.5 m/s (1475 FPM)

Temperature Rating

-35 to 82°C (-30 to 180°F)

Outer Material

Stainless Steel

Insert Material

83A Urethane

Horizontal Clearance Required

100mm (4")

Vertical Clearance Required

200mm (8")

Belt Direction

One Way

Pole Length

Cleaner size up to
1200mm (48") + 750mm (30")
Cleaner size 1350mm (54")
and up + 850mm (34")

Maximum Conveyor Span

Cleaner size up to
1200mm (48") + 625mm (25")
Cleaner size 1350mm (54")
and up + 725mm (29")

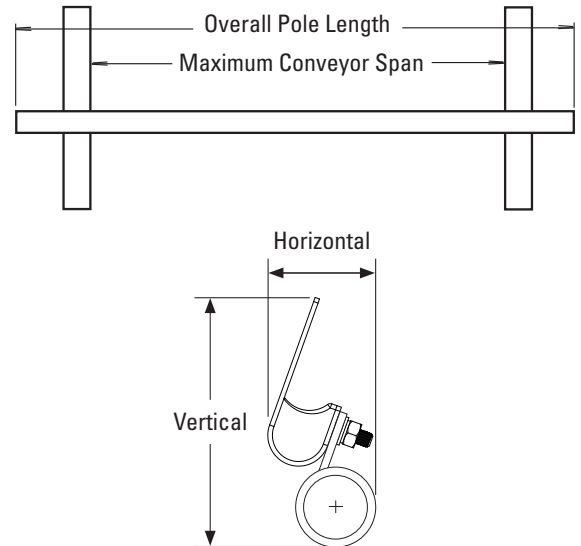

Ordering Information

Replacement Cushions	
Ordering Number	Item Code
PXTC	107137

Flexcrete™ Cushions Required per Cleaner Size											
mm	450	600	750	900	1050	1200	1350	1500	1800	2100	2400
in.	18	24	30	36	42	48	54	60	72	84	96
No. Cushions Required	3	4	5	6	7	8	9	10	12	14	16

Additional Information

For general P-Type® cleaner information, see the P-Type® Sell Sheet X3887.

Visit www.flexco.com for other Flexco locations and products, or to find an authorised distributor.

©2023 Flexible Steel Lacing Company. 02-07-25. W1859

