

THE ULTIMATE FLEX-LAG® PULLEY LAGGING TECHNICAL GUIDE

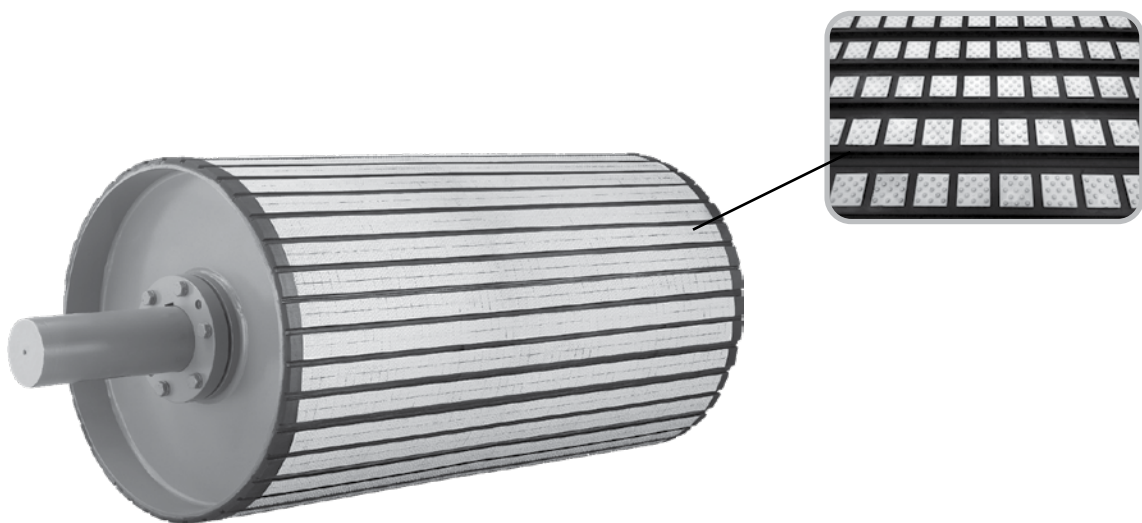

Partners in Productivity

Contents

Introduction	3
How to choose the right lagging	4
Types of Lagging	5
Flex-Lag® Rubber Specifications and Testing	6
Standard batch test report from Flexco’s rubber supplier	7
Flex-Lag Ceramic Specifications and Testing	9
Pulley Lagging Application methods	10
Glues and Adhesives	12
Fire Resistant Anti-Static Rubber	13
Calculators & Other Resources	14
Testing Equipment	15
Din Standard Test Rig in Downers Grove	16
Hydraulic Tensioning System	17
Training & Support	18
Local manufacturing	19

Introduction

Flexco Australia has been manufacturing quality, engineered ceramic and rubber lagging for more than 30 years in Sydney for the Australian market, as well as exporting to Flexco subsidiaries in 8 locations around the world.

Throughout these 30 years, Flexco has continued to expand the Flex-Lag® range to suit evolving market needs.

Historically, pulleys have always been highly engineered, but lagging was only there to protect the shell and conveyor belt. What Flexco offers now is a far cry from the vulcanized rubber sheets grooved for water dispersion, which were the norm 40 years ago.

In the mid-1980s Flexco introduced 80% ceramic dimple lagging to the market. This highly-engineered product added longevity to the lagging, but also added benefits to the conveyor design by providing a greater coefficient of friction between the ceramic and belt. This meant a reduction in counterweight and belt rating. This product was the first ceramic lagging product to market and began to offer more value than just water dispersion and pulley protection.

Fast forward to the present and Flexco remains the premier supplier of lagging in Australia, with a global engineering team dedicated to building on the foundations of the engineering knowledge first created in the 1980's. Flexco's in-house engineer, Brett DeVries, is dedicated to advancing the information surrounding pulley lagging to benefit the mining and metals industry and boost productivity for our customers.

Through the knowledge found in DeVries's white paper, Flexco can add value to your business by determining the most efficient and cost-effective lagging for drive pulleys, whether that be 80, 38, or 18 per cent ceramic coverage.

The information in this guide will help you make an informed and intelligent choice based on engineering calculations, manufacturing know-how, and variances to be aware of for your specific application. We've poured our best knowledge into this guide from our experienced team of engineers and heavy-duty field specialists.

How to Choose the Right Lagging

Below are four points that should be considered when choosing the type of Flex-Lag® required for your pulley:

1. **Conveyor Dynamics** – What is the belt rating (kN/m), operating tension (T_e), and pulley diameter?
2. **Pulley configuration** – Where on the conveyor is the pulley positioned? Drive, head, tail, or bend?
3. **Environment** – Extreme heat, cold, or moisture. Extreme heat or cold can affect the adhesion of rubber. Weld-on lagging or autoclave ready lagging may be required.
4. **Fire Resistant Anti-Static (FRAS)** – In some mining and processing areas, FRAS lagging may be required.

Once you've answered these questions, it'll be easier to select the lagging. Using the chart on the following page will help you determine what lagging is right for your pulley. However, it's always easiest to contact your local Flexco representative to help you make the decision to ensure you get it right, first go!

- Western Australia: Adam Wright, awright@flexco.com, 0459 159 151
- South Australia: Jayden Baker, jbaker@flexco.com, 0459 159 150
- Queensland, Northern Territory & Papua New Guinea: Phil Dreghorn, pdreghorn@flexco.com, 0407 632 630
- New South Wales, Victoria & Tasmania: Joshua Abberton, jabberton@flexco.com, 0458 888 716
- New Zealand: Lee Brightwell, lbrightwell@flexco.com, +64 21 762 285
- General Engineering Questions: Mark Anderson, maanderson@flexco.com, phone: +61 425 236 920

Types of Lagging

All of our lagging is manufactured in our Sydney factory. For this reason, we are able to make custom lengths as per your requirements.

Light-Duty Rubber Lagging

- Specially designed for pulleys with diameters as small as 50 mm.
- Moisture is channeled between small raised buttons that support and grip the belt and deliver superior traction.
- Available in SBR and White Nitrile.
- Can be made in rolls up to 75m long, dependent on lagging thickness.



Belt Width: Any Width

Plain-Pattern Rubber Lagging

- Helps prevent belt slippage in dry environments.
- Provides larger surface contact area relative to other patterned lagging.
- Horizontal grooves channel water and debris while providing a better dynamic interaction with the belt compared to sheet lagging.
- Available with FRAS-approved rubber, marked in blue for easy identification on site.



FRAS

Belt Width: Any Width

Diamond-Pattern Rubber Lagging

- Diamond pattern features a bidirectional design for superior water-shedding characteristics.
- Horizontal grooves provide a second method to disperse water and debris off the lagging and prevent hydroplaning.
- Performs well in both dry and wet applications.
- Available with FRAS-approved rubber, marked in blue for easy identification on site
- Available in rolls up to 75m.

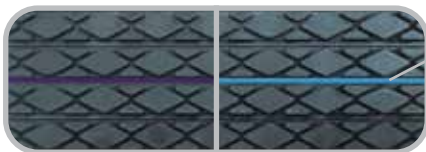

FRAS

Belt Width: Any Width

Diamond Pattern Ceramic Lagging

- 15% tile coverage.
- Large ceramic tile is molded into the diamond section, providing an increased coefficient of friction vs. Diamond-Pattern Rubber.
- Also features a bidirectional design for superior water-shedding characteristics.
- Uses the advantages of a ceramic product at a more affordable cost in light or medium duty applications.
- Available with FRAS-approved rubber, marked in blue for easy identification on site.



FRAS

Belt Width: Any Width

Medium Ceramic Lagging

- 39% tile coverage.
- Ceramic tiles increase coefficient of friction between the belt and drive pulley in wet or variable conditions.
- Constructed from individual ceramic tiles molded into a high-durometer rubber for excellent abrasion resistance.
- Molded ceramic buttons grip the belt's underside for positive traction.
- Excellent friction for mid-range tension belts.
- Available with FRAS-approved rubber, marked in blue for easy identification on site.
- Smooth ceramic available on demand. Also available in 40 metre rolls.



FRAS

Belt Width: from 450 - 3000 mm

Full Ceramic Lagging

- 80% tile coverage.
- Ceramic tiles increase coefficient of friction between the belt and drive pulley in wet or variable conditions.
- Constructed from hundreds of individual ceramic tiles molded into a durable rubber backing with a higher coverage than Medium Ceramic for best-in-class abrasion resistance.
- Molded ceramic buttons grip the belt's underside for positive traction.
- Best for high-tension belts.
- Available with FRAS-approved rubber, marked in blue for easy identification on site.
- Smooth ceramic available on demand.

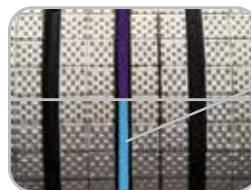

FRAS

Belt Width: from 450 - 3000 mm

Weld-On Ceramic Lagging

- 74% tile coverage.
- Weld-On design allows for quick, in-situ installation.
- Gear-tooth layout protects cleaners on pulley from experiencing "chatter" and premature wear.
- Constructed from hundreds of individual ceramic tiles molded into a durable rubber backing.
- Most consistent performance in dry, wet or muddy applications.
- Molded ceramic buttons grip the belt's underside for positive traction.
- Also available in rubber and FRAS.



Minimum Pulley Diameter: 400 mm
Belt Width: from 450 - 1800 mm

Flexco Pulley Lagging Adhesives

Flex-Lag® adhesives are a two-part cold bonding system designed specifically for use with rubber-to-rubber and rubber-to-metal adhesion. Flex-Lag adhesives are also produced without using chlorofluorocarbons (CFCs). An excellent bond is achieved while using minimal amount of cement and primer thanks to high adhesion during installation and after curing.



Flex-Lag® Rubber Specifications and Testing

Test requirements	Natural	FRAS	Test Standard
Hardness, Shore "A" Duro	68 +-3	68 +-3	ATSM D2240
Specific Gravity g/cm3	1.13	1.29	D297
Tensile Strength MPa	18.7	19.3	D412
Elongation @ Break %	540	645	D412
Tear Resistance, Angle, N/mm	61.1	55.4	D624-00 Die C
Abrasion Loss, mm3	64.7	184.5	AS1683.21
Adhesion Test, N/mm	>12	>12	D429

Rubber Hardness – The rubber hardness is measured with a durometer on every strip. The shore "A" duro is similar to the hardness of the rubber conveyor belt covers.

Specific Gravity – The mechanical property of the product to estimate the weight of a lagged pulley.

Tensile Strength – The higher the tensile strength, the more tolerant it is to harsher conditions and friction, specifically between the belt and the pulley, without tearing.

Elongation – The higher the elongation, the more flexible the rubber is. It can conform more without permanent deformation to the rubber in harsh conditions.

Tear Resistance – Similar to tensile strength. The difference is it's done with intentional damage made to the sample, to see how it reacts to a situation and propagates through.

Adhesion Test – Measures the bond strength between the rubber and steel.



Quality Engineer conducting test ASTM-D429 at Flexco Australia's Internal Cold Bond Testing Facility.

Standard batch test report from Flexco's rubber supplier

The batch test report is linked to the adhesion tests and can be referenced back to the date of manufacture imprinted on the strip of lagging. The report provides confidence the specific batch of rubber is as per our specification and a consistent, quality product.

Test Report

Report Date : Friday, 7 May 2021 9:02:16 AM
 Rubber Code : F3805/2
 Test Date : Tuesday, 27 April 2021
 Test Type : MDR
 Workstation : MDR1
 Die Temperature : 177.0 C

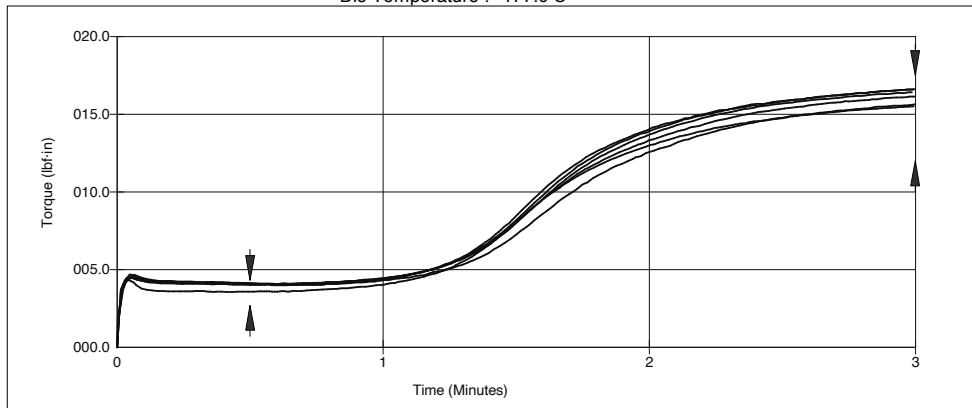

Parameter Results:

Test ID.	ML	MH	Ts1	Tc90	Pass/ Fail
Upper Limit	4.20	17.50	1.30	2.50	
Lower Limit	2.80	12.00	0.80	1.70	
2124	3.56	15.54	1.16	2.32	Pass
2125	3.99	15.66	1.24	2.40	Pass
2126	4.05	16.14	1.19	2.35	Pass
2127	4.01	16.63	1.18	2.31	Pass
2128	4.07	16.65	1.20	2.33	Pass
2129	4.05	16.43	1.19	2.32	Pass

*Test Notes and Comments

Test ID.	*Test Notes or Comments
2129	CUSTOMER: FLEXCO MIXED: 27.4.21 AM BATCHES: 1-6 MIXER# 2 HARDNESS: 70-71 SH "A" SHELF LIFE FROM DOM: 90 DAYS These batches conform to the standards set by the customer

End of Report

Rheology is the branch of physics where we study the way in which materials deform or flow in response to applied forces or stresses. By observing and recording the rheological from our rubber supplier, we ensure the rubber properties stay the same and our processes are integral and consistent.

Natural Rubber Adhesion Test after 2 Hours (16.67 N/mm)

Specimen details

Specimen ID	Date	Time	Type	Gauge Length
MAY-NAT-CER-1_06032021_162114	3/6/2021	4:21 PM	Flat	75.0mm

Specimen ID	Width	Thickness
MAY-NAT-CER-1_06032021_162114	32.0mm	12.0mm

Test Results

	MaxLoad	AvgLdDispRng	MaxLoW
Unit	N	N	N/mm
Lower limit	0.00	0.00	0
Upper limit	0.00	0.00	0
	533.52	278.94	0

Test Results

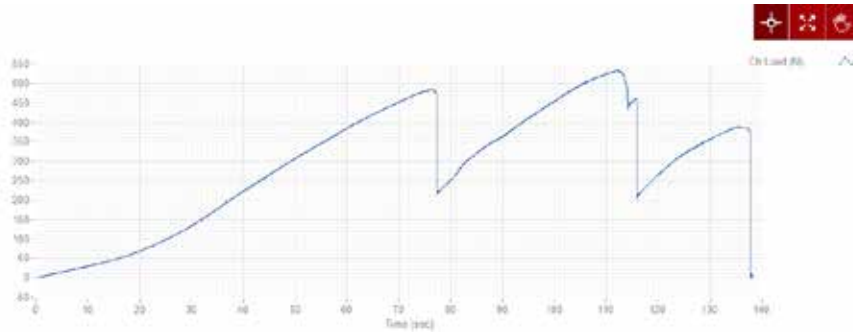

FRAS Rubber Adhesion Test after 24hrs (18.36 N/mm)

Specimen details

Specimen ID	Date	Time	Type	Gauge Length
MAY-FRAS-CER-1_06032021_160544	3/6/2021	4:05 PM	Flat	75.0mm

Specimen ID	Width	Thickness
MAY-FRAS-CER-1_06032021_160544	32.0mm	6.3mm

Test Results

	MaxLoad	AvgLdDispRng	MaxLoW
Unit	N	N	N/mm
Lower limit	0.00	0.00	0
Upper limit	0.00	0.00	0
	587.50	169.48	1

Test Results

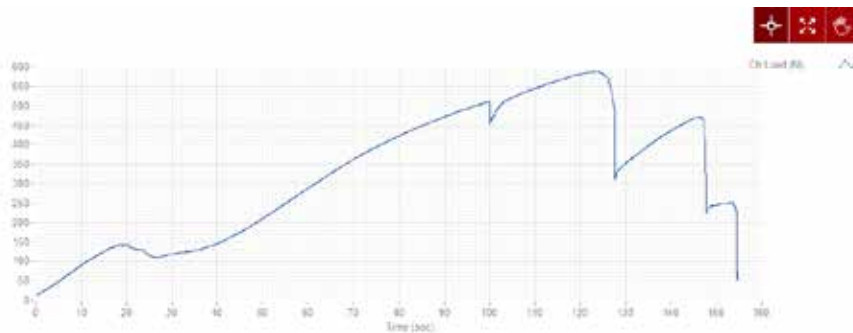

Flex-Lag® is made from the finest quality rubber to ensure it provides maximum protection, longevity, and the best friction ratio between the belt and the pulley. Flexco’s regular testing guarantees that the strips will adhere to the pulley effectively using Flex-Lag adhesives.

Flex-Lag® Ceramic Specifications and Testing

Test Requirements	Result	Test Method
Ceramic Tile Vickers Hardness	>1500	GB/T 16534
Aluminium Oxide	95%	ICP-AES
Tile to Rubber adhesion	100% Rubber Tear	Pull test
Impact resistance	0.34 J	D5420-04

Spectrometric Test – Analyses the chemical composition of the tile and measures the amount of each element. The spectrometric testing is carried out to ensure all of the ceramic tiles used are made of the same chemical composition.

Vickers Test – Measures the hardness of the ceramic tile. The greater the hardness, the greater the impact resistance will be, which will ensure the tiles will not chip or crack. This is important when considering the coefficient of friction between ceramic dimple tiles and the belt when the tiles encounter hard material stuck between the belt and the pulley.

Tile Bond Strength – Tests that the bond between the tiles and the rubber is greater than the rubber tear resistance. This will ensure the tiles will not debond and fall out, even in the harshest conditions.

Impact Resistance – Ensures the tiles will not chip and crack when they come in contact with material between the belt and the pulley.

Spectrometer Batch Test

SPECTROMETER SERVICES PTY. LTD.

SPECTROGRAPHIC AND CHEMICAL ANALYSTS

A.B.N. 20 004 505 426

ACN 004 505 426

206 Newlands Road, Coburg 3058

P.O. Box 135, Coburg 3058

Phone (03) 9350 1766

Fax (03) 9354 1052

Report Number : 83206

Report Date : Monday, 28 June, 2021

Job Number : D21/1513

Cust. Order No.:

FLEXCO AUSTRALIA P/L
PO BOX 6365
NORWEST NSW 2153

ATTENTION : Phil Brodbeck

Certificate Of Analysis

Samples	SiO ₂ %	Al ₂ O ₃ %	Fe ₂ O ₃ %	CaO %	MgO %	Na ₂ O %	K ₂ O %	MnO %	TiO ₂ %	P ₂ O ₅ %	ZnO %	CuO %	Cr ₂ O ₃ %	MoO ₃ %
Tile Dimple P2924 20*20*5mm	2.42	95.3	0.10	1.55	0.08	0.22	0.04	<0.01	0.20	<0.01	<0.01	<0.01	<0.01	<0.01

Methods Used
ICP-AES

Notes:

Results wt/wt on samples as received

2<SiO₂<3-Pass

94.3<Al₂O₃<95.3-Pass

Bernard Hedger

Pulley Lagging Application methods

Cold Bonding

The cold bonding method requires the lagging strips to be bonded directly to the steel pulley shell by using a primer, rubber-based adhesives, and an activator chemical.

- Suitable for natural and FRAS rubber, as well as ceramic lagging.
- Rubber to steel adhesion between 12N/mm and 15N/mm.
- Able to be applied in the workshop or on-site.
- Average installation time is approximately 4 hours (based on a pulley that has a diameter of 800mm and a 1950mm face).

CN Lined Bonding

The cold bonding method utilises a 1.5mm CN filler to line the entire pulley face. The CN filler adhesion is the perfect substrate for increased adhesion and sealing of joints and edges.

- Suitable for natural and FRAS rubber, as well as ceramic lagging.
- Rubber to steel adhesion between 14N/mm and 20N/mm.
- Able to be applied in the workshop or on-site.
- Average installation time is approximately 5.5 hours (based on a pulley that has a diameter of 800mm and a 1950mm face).



Hot Vulcanized Bonding

This process involves heat, pressure, and time to cure uncured rubber to the pulley shell. This process is carried out in an autoclave. The shell can be lined with the required thickness of uncured rubber and then grooved to a diamond or herringbone pattern.

Alternatively, strip ceramic and rubber lagging can be lined with 1mm uncured rubber skim and applied to the pulley similar to a cold bonding application. The pulley is then cooked in an autoclave.

- Suitable for natural and FRAS rubber, as well as ceramic lagging.
- Rubber to steel adhesion between 18N/mm and 20N/mm.
- Able to be applied in the workshop only.
- Average installation time is approximately 14 hours (based on a pulley that has a diameter of 800mm and a 1950mm face).

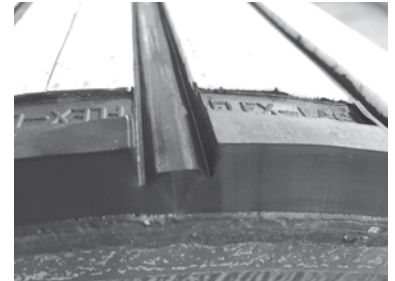

Weld on or Slide Lagging

The rubber or ceramic is molded to a steel plate and then welded to the pulley; alternatively, tracks are welded to the pulley for the metal-backed strips to slide in.

- Suitable for natural and FRAS rubber, as well as ceramic lagging.
- Rubber to steel adhesion 20N/mm.
- Able to be applied in the workshop or on-site.
- Average installation time is approximately 5 hours (based on a pulley that has a diameter of 800mm and a 1950mm face).

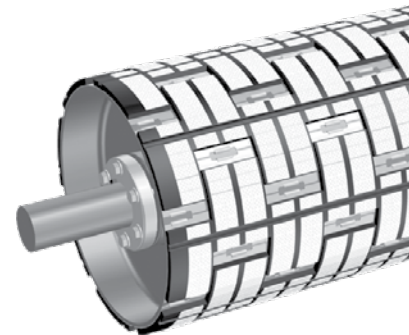

In situ Lagging

Lagging the Pulleys in situ removes all of the issues and time involved when removing and installing a replacement pulley.

FlexLag® strips were designed for ease of lagging pulley's on-site in situ. The 200mm-wide strips make for easier application while applying the strips to pulleys in areas that might have limited space. These are also lighter, which makes correct fitment much easier.

Glues and Adhesives



Technical Data:

Adhesive: Flex-Lag® Adhesive

Solvents: Ethyl acetate, acetone, hexane, heptane.

Density: 0.86g/cm cubed

Activator: Flex-Lag® Hardener RE

Components: Ethyl acetate, chlorobenzene, tri-isocyanate.

Pot Life: approx. 3 hours at room temperature.

Drying Time: Coat of Flex-Lag Primer – minimum 10 mins, maximum 1 week at 23 -25 degrees Celsius.

1st coat Flex-Lag Adhesive – minimum 25 mins, maximum 24 hrs at 23 - 25 degrees Celsius.

2nd coat Flex-lag Adhesive – minimum 6 mins, maximum 10 mins or *back of hand test at 23 - 25 degrees Celsius.

Fire Resistant Anti-Static Rubber

Flex-Lag® FRAS rubber is tested every 5 years to MDG3608 as per regulations.

Sample description F3805 is referenced in Flexco’s rubber suppliers batch testing, so there is tractability.



Regional
NSW

Mine Safety
**TECHNOLOGY
CENTRE**

Adrian Woodbury
Flexco (Aust) Pty. Ltd.
10 Solent Circuit
NORWEST N.S.W. 2153

10th of January, 2022

M.S.T.C. TEST REPORT T21-00694/0001

Company:	Flexco (Aust) Pty. Ltd.
Sample Description:	FRAS Flex-Lag lagging – black rubber
Intended Use:	Minor Conveyor Accessories [Refer to MDG3608, Sect. 3.3]
Sample No.:	T21-00694/0001



Fig. 1: Sample material

SUMMARY

The material **complied** with the Ignitability and Flame Propagation Characteristics (Finger Burn Test) requirements of MDG3608, 3.3.1.1.

The material **complied** with the Oxygen Index requirements of MDG3608, 3.3.1.2.

The material **complied** with the Electrical Resistivity requirements of MDG3608, 3.3.1.3
(- samples up to 15 mm thick).

Analysed by: A. Thompson, C. Teasdale

Checked by: 

Authorised by:

G. Slater
Manager, Mine Safety Technology Centre



Endorsed tests indicated by logo on test page

Clause 3.1.2 of MDG3608 states that all conveyor belting (Grade S) and conveyor accessories must be re-tested at least every 5 years and whenever a change in the formulation, raw-material supply, manufacturing process or manufacturing location occurs.

Calculators & Other Resources

Link to: <https://flexco.com.au/AU/EN/Flexco/Resources/Product-Calculators.htm>

Flexco has two calculators available for use to aid you in selecting the correct lagging for your application:

Lagging Traction Calculator

INPUTS	
T _e (kN)	300
wrap angle φ (deg)	200
Belt Width (mm)	1800

RESULTS	
T ₂ (kN)	400
τ _a (kPa)	78.0
p1 (kPa)	635.1
p2 (kPa)	362.9

222.2 N/mm
Results not valid unless p2 > 35 kPa

Theoretically Available Traction (kPa)										
Lagging type										
Conditions	Flexco full ceramic lagging	Flexco full ceramic smooth lagging	Flexco medium ceramic lagging	Flexco medium ceramic smooth lagging	Flexco diamond ceramic lagging	Flexco diamond rubber strip lagging	Flexco plain rubber strip lagging	Flexco FRAS diamond ceramic lagging	Flexco FRAS diamond rubber strip lagging	Flexco Light Duty Black Rubber
Clean & Dry	343.0	226.0	291.1	238.3	275.9	223.9	262.2	294.9	274.1	287.2
Wet	292.7	146.0	280.1	203.3	251.1	202.8	235.9	286.3	240.3	4:532
Muddy	275.3	108.8	214.4		205.5	172.9	N/A	200.4	203.9	N/A
Valid thicknesses (mm):	12,15, 20, 25	12,15, 20, 25	15	15	12	10, 12, 15, 20, 25	10, 12, 15, 20, 25	12	10, 12, 15, 20, 25	6

Traction Safety Factor										
Lagging type										
Conditions	Flexco full ceramic lagging	Flexco full ceramic smooth lagging	Flexco medium ceramic lagging	Flexco medium ceramic smooth lagging	Flexco diamond ceramic lagging	Flexco diamond rubber strip lagging	Flexco plain rubber strip lagging	Flexco FRAS diamond ceramic lagging	Flexco FRAS diamond rubber strip lagging	Flexco Light Duty Black Rubber
Clean & Dry	4.4	2.9	3.7	3.1	3.5	2.9	3.4	3.8	3.5	3.7
Wet	3.8	1.9	3.6	2.6	3.2	2.6	3.0	3.7	3.1	3.3
Muddy	3.5	1.4	2.7	No Data	2.6	2.2	No Data	2.6	2.6	No Data

This calculator will allow you to input your belt specifications to calculate the theoretically available traction as well as a traction safety factor.

Lagging Cost Calculator

Found on our distributor portal, this calculator enables the user to input information about their pulley to calculate the materials needed and the associated cost.

FLEX-LAG

Belt Width: 400
Pulley Face Width: 1800
Overhang Per Strip: 100
Pulley Diameter: 800
No. of pulleys: 1
Lagging Thickness: 6
Lagging Type: Neutral Diamond
Tins Required: 8
Strips Required: 0

FLEX-LAG ADHESIVE

Tin Size (L): 0.8
No of Tins: 8

FLEX-LAG PRIMER

Tins Needed: 1

FLEX-LAG ACTIVATOR

Activator Amount (Tins): 8

COSTING

Lagging Cost (List Price): \$0.00
Glue Cost (List Price): \$48.00
Activator Cost (List Price): \$120.00
Primer Cost (List Price): \$108.00

Total Cost (List Price): \$0

Lagging Discount: 25
Lagging Discounted Price: \$0.00
Glue/Primer/Activator Discount: 25

Total Cost (With Discounts): \$0

Please note, if the total cost is displaying a \$0 value it is because some of the selections you have entered are unavailable. Please check these specifications or contact us directly for custom lagging orders.

Testing Equipment



Durometer

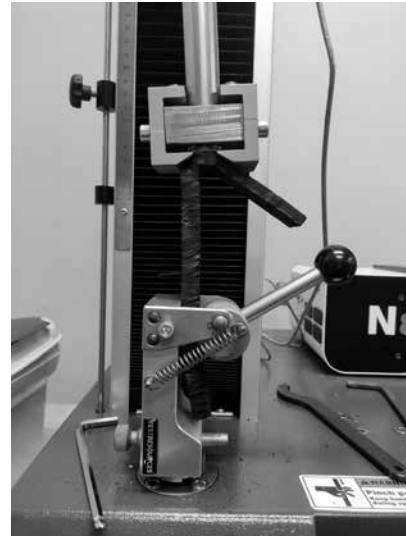

Tile Adhesion



***Tensile Strength and
Elongation Test***



***Rubber to Full Ceramic
Adhesion***

DIN

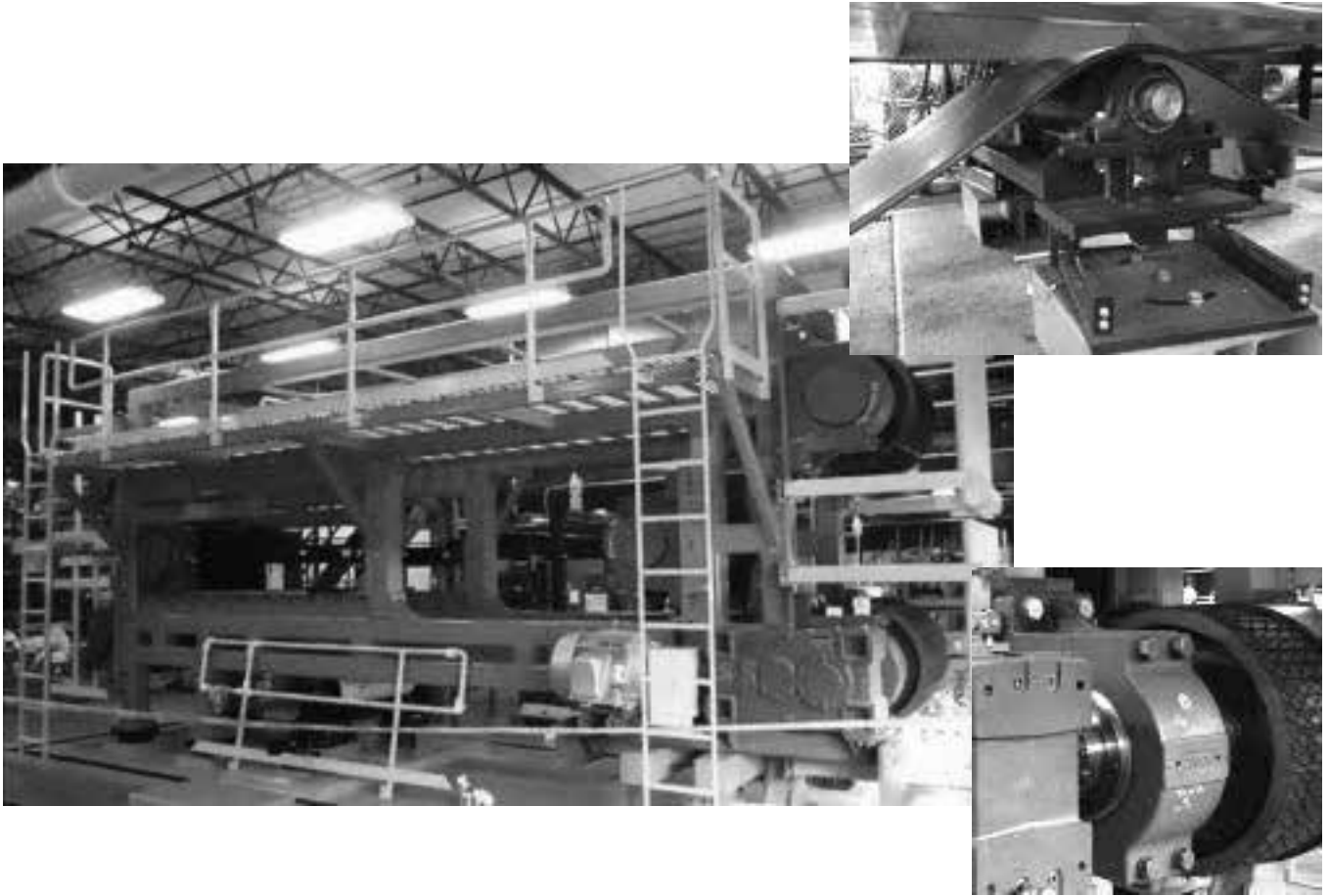

The DIN standard test rig was built in 2011 to test lagging and fastener products in-house. Flexco's diverse product offering, combined with increased belt tensions and the continuing evolution of belt construction, prompted Flexco to invest in the new DIN standard test rig. The rig's ability to change tensions, pulley diameters, and wrap angles has proven invaluable in understanding the dynamics of pulley lagging traction and peel forces.

Hydraulic Tensioning System

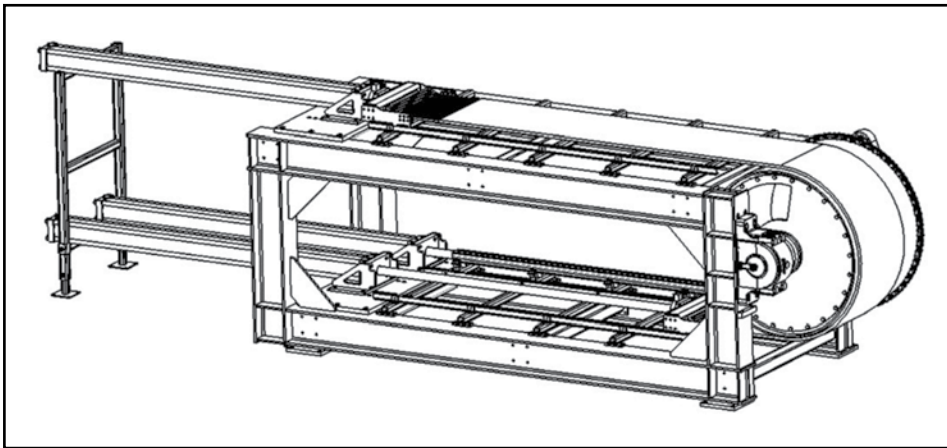
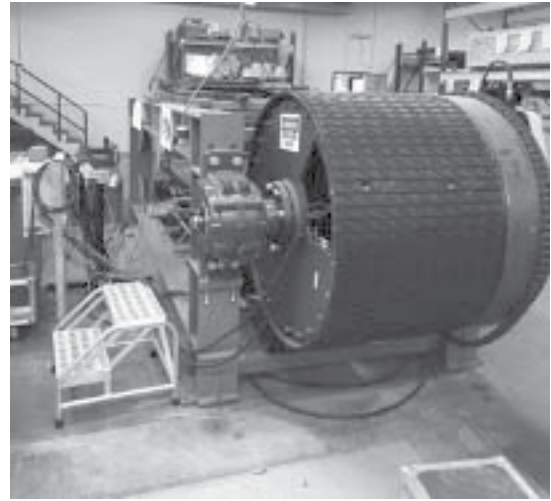

The hydraulic tensioning system was designed to measure wrap pressure, lagging shear angle movement, and absolute belt displacement for various lagging and belt types on a pulley being rotated through a 180° wrap angle. Data collection would begin approximately 10° before the entry nip point (top dead centre) and continue until 10° past the exit nip point. Each

tension cylinder had a 50 kN load cell to measure force. To separately measure the lagging shear strain and the belt movement, mechanical sensor elements were installed inside a custom 1219mm diameter pulley. The pulley was installed in a steel framework such that hydraulic cylinders could apply adjustable T1 and T2 tensions while the pulley was rotated. Due to the slow speed of the test, the measurements were considered to be nearly static. An average test would take approximately 2 minutes. The hydraulic pressure in each cylinder was controlled with an adjustable spring-based relief valve.

Training & Support

Our product support at Flexco is second-to-none. We provide a vast array of training options to our customers.

Flexco University Online provides professional training on mechanical belt fastening, belt conveyor products, and belt maintenance. Courses are available at www.flexcouniversity.com and can be accessed anytime that is convenient. Three levels of courses are available through this program, with each course lasting between 30 and 60 minutes.

Individuals can take courses at their own pace and can choose to take all courses or only the most relevant ones. Course completion certificates are available to help document site-specific training requirements. Additionally, you can choose to manage your own online training groups by assigning different courses, monitoring participant progress, reporting, and more.

Flexco also offers a wide variety of hands-on, in-person training options in our facilities, or yours.

The Flexco team of Heavy-Duty Field Specialists are situated all over the world and can help our customers solve any challenge along the belt line and provide extensive training and support. Flexco Heavy-Duty Field Specialists have made significant upgrades on sites across the globe.

Local manufacturing

Flex-Lag® may be the oldest lagging product on the Australian market, but we certainly haven't ceased to innovate our product at every possible opportunity to ensure our customers have the best product available.

Flexco's continuous investment into manufacturing technology, material sourcing, and most importantly—investment into quality assurance—has ensured that Flexco has maintained its status as the premier supplier of premium lagging in Australia for more than 30 years.



Flexco employs 24 manufacturing staff in Sydney with a strong focus on cultural diversity. Flexco employs staff from 11 different countries.



Flexco manufactures over 76 km of rubber and ceramic lagging each year, that's enough to pave the way from the Gold Coast to Brisbane!



Flexco processes 210 tonnes of rubber each year - that's equivalent to the weight of over 5 Boeing 737 aircraft.



Flexco (Aust.) Pty. Ltd • 10 Solent Circuit, Norwest • NSW, Australia, 2153 • Australia
Tel: 612-8818-2000 • Fax: 612-8824-6333 • E-mail: salesau@flexco.com

Visit www.flexco.com for other Flexco locations and products.

©2022 Flexible Steel Lacing Company. 10/25/22. For reorder: W1202



Partners in Productivity