

List Price Sheet

Y-Type with Red UHT Polyurethane Blade

Y-Type™ Standard Duty with Red UHT Polyurethane Blades

BELT WIDTH	ORDERING NUMBER	ITEM CODE	WT. KG
mm			
450	YTR-18S	91798	26.8
600	YTR-24S	91799	29.5
750	YTR-30S	91800	32.2
900	YTR-36S	91801	34.9
1050	YTR-42S	91802	37.6
1200	YTR-48S	91803	40.4

Lead time: 1 working day



Y-Type™ HD with Red UHT Polyurethane Blades

BELT WIDTH	ORDERING NUMBER	ITEM CODE	WT. KG
mm			
900	YTHDR-36S	91816	59.4
1050	YTHDR-42S	91817	63.5
1200	YTHDR-48S	91818	68.0
1350	YTHDR-54S	91819	71.7
1500	YTHDR-60S	91820	76.2
1800	YTHDR-72S	91821	84.4

Lead time: 1 working day

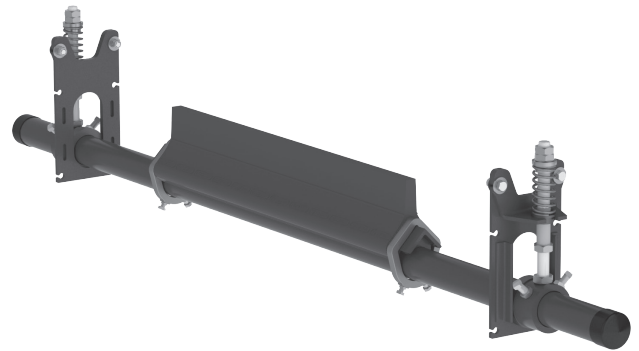

Product Notes:

- Works on reversing belts, vulcanized belts, and belts with mechanical fasteners.
- Pole Length: **SD**: Belt width plus 30" (750mm), **HD**: Belt width plus 54" (1350mm). For longer requirements, see Installation Accessories – Pole Extender Kit.
- Visual Blade Tension Check: Measure the tension spring and refer to Spring Length Chart on mounting base for the correct length for best cleaning performance.
- Tensioner: Standard Duty YST Spring Tensioner for self-adjusting tensioning with easy retensioning adjustments. The tensioner can be mounted in pull-up or push-up position.
- To make cleaner installation easier and quicker, see Optional Mounting Kits on replacement parts page.
- Simple design makes changing the blades fast and easy. Blades can be removed and replaced individually, or all at once by replacing the cartridge.

U.S. Patent No. 9,586,765

Stock items (non-shaded) refer to (*) for specific lead time, if not specified, standard lead time applies.

Non-stock items (shaded) please contact Flexco for dispatch options and lead times.



List Price Sheet

Y-Type with Red UHT Polyurethane Blade

Replacement Blades/Cartridges Standard Duty Red UHT Polyurethane

BELT WIDTH mm	ORDERING NUMBER	ITEM CODE	WT. KG
-	YT-R*	91804	0.5
450	YCART-18/450-R	91805	5.9
600	YCART-24/600-R	91806	7.7
750	YCART-30/750-R	91807	9.5
900	YCART-36/900-R	91808	11.3
1050	YCART-42/1050-R	91809	13.2
1200	YCART-48/1200-R	91810	15.0

Single 75mm blade segment
Lead time: 1 working day

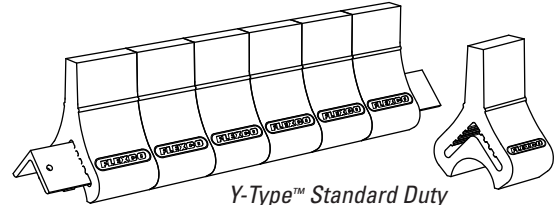

Y-Type™ Standard Duty
Polyurethane Blade Cartridge

Replacement Blades/Cartridges HD Red UHT Polyurethane

BELT WIDTH mm	ORDERING NUMBER	ITEM CODE	WT. KG
-	YT-HDR*	91822	1.7
900	YCART-36/900-HDR	91823	36.5
1050	YCART-42/1050-HDR	91824	42.3
1200	YCART-48/1200-HDR	91825	48.1
1350	YCART-54/1350-HDR	91826	53.9
1500	YCART-60/1500-HDR	91827	59.8
1800	YCART-72/1800-HDR	91828	71.4

Single 75mm blade segment
Lead time: 1 working day

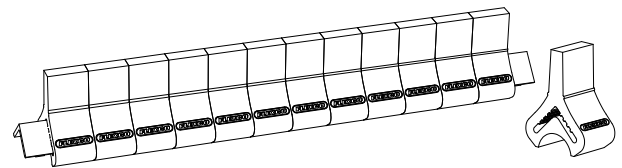

Y-Type™ HD Polyurethane Blade Cartridge

U.S. Patent No. 9,586,765

Stock items (non-shaded) refer to (*) for specific lead time, if not specified, standard lead time applies.

Non-stock items (shaded) please contact Flexco for dispatch options and lead times.



Specifications and Guidelines

Y-Type SD with Red UHT Polyurethane Blade

Pole Length Specifications

Cleaner Size		Pole Length		Maximum Conveyor Span	
mm	in.	mm	in.	mm	in.
450	18	1200	48	1025	40
600	24	1350	54	1175	46
750	30	1500	60	1325	52
900	36	1650	66	1475	58
1050	42	1800	72	1625	64
1200	48	1950	78	1775	70

Pole Length - Belt +750mm
Pole Diameter - 60mm

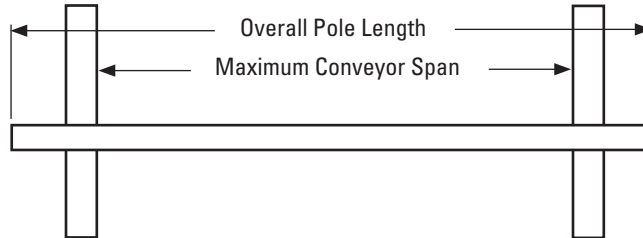

Clearance Guidelines for Installation

Cleaner Type	Belt Width/Cleaner Size		Horizontal Clearance Required		Vertical Clearance Required	
	mm	in.	mm	in.	mm	in.
Y-Type® Polyurethane	450 -1200	18 - 48	110	4-1/4	210	8 1/4
Y-Type Carbide	450 -1200	18 - 48	110	4-1/4	184	7 3/8

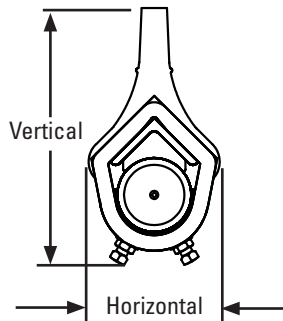

Y-Type Blade Specifications

Cushion	Durometer	Temperature Range
Purple (Standard)	86A	-35° to 82° C
White (Food Grade)‡	83A	-35° to 82° C
Red (Ultra High-Temp)	90A	Up to 200° C Spikes to 232° C
Carbide	86A	-35° to 82° C

‡All ingredients used in the polyurethane formulation of this blade comply with the relevant requirements of 21 CFR (FDA Code of Federal Regulations) for use in repeated bulk dry food applications

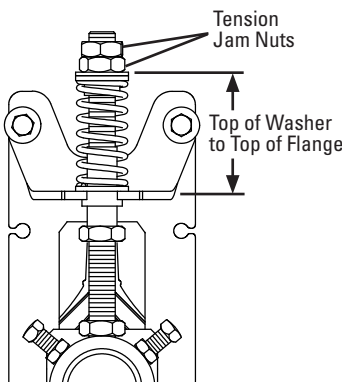

Pull-Up Tensioner Configuration (SD)

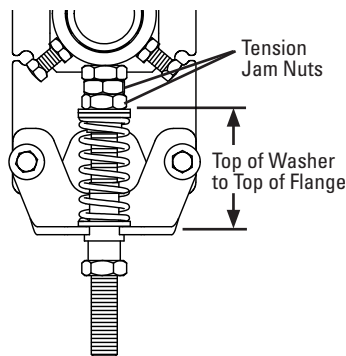

Push-Up Tensioner Configuration (SD)

YST SD Tensioner Spring Length Chart

Blade Width	Carbide Tip		Purple or White Polyurethane Tip				Red UHT Polyurethane Tip				
	Silver Springs		Yellow Springs		Purple Springs		Yellow Springs		Purple Springs		
mm	in.	mm	in.	mm	in.	mm	in.	mm	in.	mm	in.
450	18	105	4 1/8	83	3 1/4	92	3 5/8	79	3 1/8	92	3 5/8
600	24	102	4	73	2 7/8	86	3 3/8	70	2 3/4	86	3 3/8
750	30	98	3 7/8	67	2 5/8	79	3 1/8	64	2 1/2	79	3 1/8
900	36	95	3 3/4	57	2 1/4	73	2 7/8	57	2 1/4	73	2 7/8
1050	42	92	3 5/8	NA	NA	67	2 5/8	NA	NA	67	2 5/8
1200	48	89	3 1/2	NA	NA	60	2 3/8	NA	NA	60	2 3/8

Shading indicates preferred spring option.

Specifications:

- Maximum Belt Speed..... 3 m/s (600 FPM)
- Usable Blade Wear Length..... 50mm (Polyurethane)
6mm (Carbide)
- Blade Materials **Purple:** Polyurethane (proprietary blend for abrasion resistance and long wear)
White: Polyurethane (chemical resistant/food grade)
Red: Polyurethane (ultra high-temp)
Carbide: Tungsten Carbide
- Available for Belt Widths 450 to 1200mm. Other sizes available upon request.
- CEMA Cleaner Rating Class 2 (Standard-duty with polyurethane blades)
Class 3 (Standard-duty with Carbide blades)

Specifications and Guidelines

Y-Type HD with Red UHT Polyurethane Blade

Pole Length Specifications

Cleaner Size		Pole Length		Maximum Conveyor Span	
mm	in.	mm	in.	mm	in.
900	36	2286	90	2083	82
1050	42	2438	96	2235	88
1200	48	2590	102	2388	94
1350	54	2743	108	2540	100
1500	60	2895	114	2692	106
1800	72	3200	126	2997	118

Pole Length - Belt +1350m
Pole Diameter - 73mm

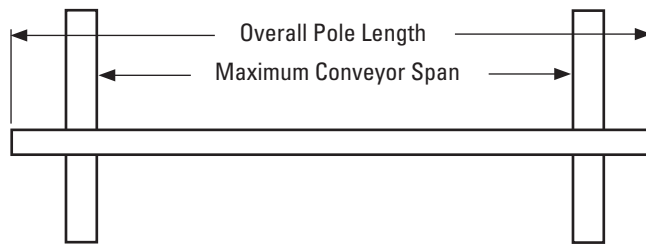

Clearance Guidelines for Installation

Cleaner Type	Belt Width/Cleaner Size		Horizontal Clearance Required		Vertical Clearance Required	
	mm	in.	mm	in.	mm	in.
Y-Type® HD Polyurethane	900 -1800	36 - 72	133	5/1/04	241	9/1/02
Y-Type HD Carbide	900 -1800	36 - 72	133	5/1/04	248	9/3/04

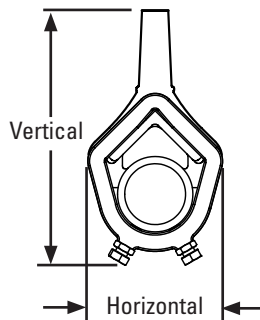

Y-Type Blade Specifications

Cushion	Durometer	Temperature Range
Purple (Standard)	86A	-35° to 82° C
White (Food Grade)‡	83A	-35° to 82° C
Red (Ultra High-Temp)	90A	Up to 200° C Spikes to 232° C
Carbide	N/A	-35° to 82° C

‡All ingredients used in the polyurethane formulation of this blade comply with the relevant requirements of 21 CFR (FDA Code of Federal Regulations) for use in repeated bulk dry food applications

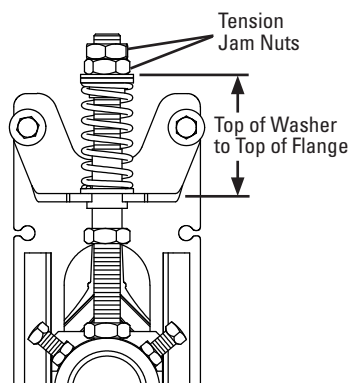

Pull-Up Tensioner Configuration (HD)

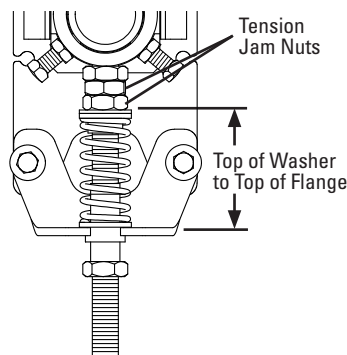

Push-Up Tensioner Configuration (HD)

YST HD Tensioner Spring Length Chart

Blade Width	Carbide Tip				Polyurethane Tip				
	Silver Springs		Black Springs		Green Springs		Blue Springs		
mm	in.	mm	in.	mm	in.	mm	in.	mm	in.
900	36	98	3 7/8	102	4	76	3	86	3 3/8
1050	42	95	3 3/4	98	3 7/8	73	2 7/8	83	3 1/4
1200	48	92	3 5/8	95	3 3/4	67	2 5/8	79	3 1/8
1350	54	89	3 1/2	95	3 3/4	64	2 1/2	76	3
1500	60	86	3 3/8	92	3 5/8	NA	NA	73	2 7/8
1800	72	83	3 1/4	89	3 1/2	NA	NA	64	2 1/2

Shading indicates preferred spring option.

Specifications:

- Maximum Belt Speed..... 3.8 m/s (750 FPM)
- Usable Blade Wear Length..... 76mm (Polyurethane)
10mm (Carbide)
- Blade Materials **Purple:** Polyurethane (proprietary blend for abrasion resistance and long wear)
White: Polyurethane (chemical resistant/food grade)
Red: Polyurethane (ultra high-temp)
Carbide: Tungsten Carbide
- Available for Belt Widths 900 to 1800mm. Other sizes available upon request.
- CEMA Cleaner Rating Class 3 (Heavy-duty with polyurethane or carbide blades)

U.S. Patent No. 9,586,765

Flexco (Aust.) Pty. Ltd • 10 Solent Circuit, Norwest • NSW, Australia, 2153 • Australia
Tel: 612-8818-2000 • Fax: 612-8824-6333 • E-mail: salesau@flexco.com

Visit www.flexco.com for other Flexco locations and products.

©2021 Flexible Steel Lacing Company. 08/19/21. For PDF: W1201

