

Belt Support Bar

Installation, Operation and Maintenance Manual

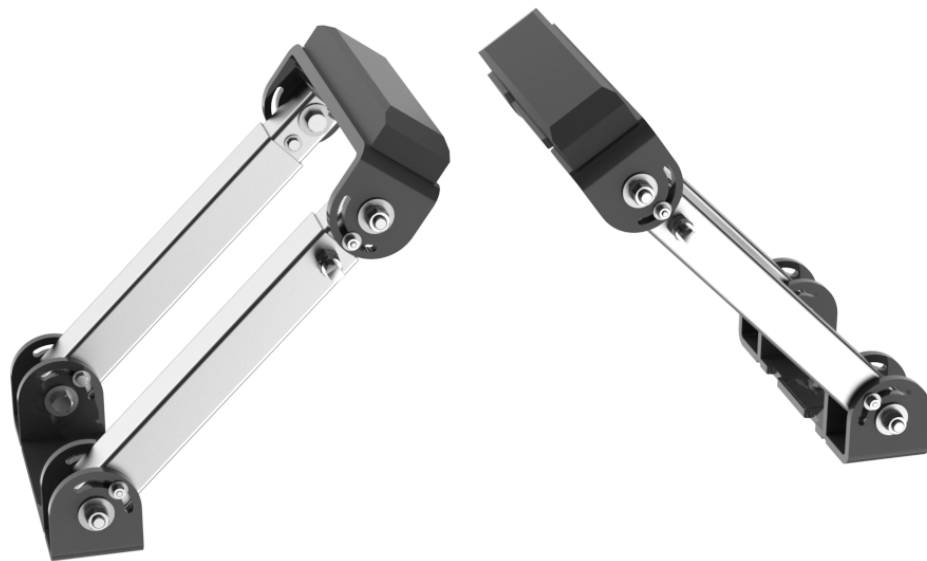

Belt Support Bar

Serial Number:	_____
Purchase Date:	_____
Purchased From:	_____
Installation Date:	_____

Serial number information can be found on the Serial Number Label included in the Information Packet found with the belt support bar.

This information will be helpful for any future inquiries or questions about replacement parts, specifications or troubleshooting.

Table of Contents

Section 1 - Important Information	4
1.1 General Introduction.....	4
1.2 User Benefits	4
1.3 Service Option	4
1.4 Proper Belt Support Bar Selection	5
Section 2 - Safety Considerations and Precautions	6
2.1 Stationary Conveyors.....	6
2.2 Operating Conveyors.....	6
Section 3 - Pre-Installation Checks and Options.....	7
3.1 Checklist.....	7
Section 4 - Installation Instructions.....	8
4.1 Belt Support Bar	8
Section 5 - Pre-Operation Checklist and Testing.....	10
5.1 Pre-Op Checklist.....	10
5.2 Test Run the Conveyor	10
Section 6 - Maintenance.....	11
6.1 New Installation Inspection.....	11
6.2 Routine Visual Inspection.....	11
6.3 Routine Physical Inspection	11
6.4 Bar Replacement Instructions	12
6.5 Maintenance Log.....	13
6.6 Maintenance Checklist	14
Section 7 - Troubleshooting	15
Section 8 - Specs and CAD Drawings.....	16
8.1 CAD Drawings	16
Section 9 - Replacement Parts	17
Section 10 - Other Flexco Conveyor Products.....	19

Section 1 - Important Information

1.1 General Introduction

We at Flexco are very pleased that you have selected a Belt Support Bar for your conveyor system.

This manual will help you to understand the operation of this product and assist you in making it work up to its maximum efficiency over its lifetime of service.

It is essential for safe and efficient operation that the information and guidelines presented be properly understood and implemented. This manual will provide safety precautions, installation instructions, maintenance procedures and troubleshooting tips.

If, however, you have any questions or problems that are not covered, please visit our web site or contact our Customer Service Department.

Visit www.flexco.com for other Flexco locations and products.

Please read this manual thoroughly and pass it on to any others who will be directly responsible for installation, operation and maintenance of this cleaner. While we have tried to make the installation and service tasks as easy and simple as possible, **it does however require correct installation and regular inspections and adjustments to maintain top working condition.**

1.2 User Benefits

The “transfer point” is integrally important to the successful operation of a belt conveyor system. The material transferred from one conveyor (or other source) to another conveyor must be done without damaging the conveyor’s key component...the belt. A correctly-selected belt support bar is critical for this task

Correct installation and regular maintenance will provide the following benefits for your operation:

- Reduced conveyor downtime
- Reduced man-hour labor
- Lower maintenance budget costs
- Increased service life for the belt cleaner and other conveyor components

1.3 Service Option

The Belt Support Bar is designed to be easily installed and serviced by your on-site personnel. However, if you would prefer complete turn-key factory service, please contact your local Flexco Field Engineer or your Flexco Distributor.

Section 1 - Important Information

1.4 Proper Belt Support Bar Selection

Flexco Belt Support Bars are expressly designed to help support the belt in areas between idlers that are not directly in the impact area of material. The model should be spec'd to the needs of the conveyor application.

- Belt Width** - This is typically a simple check and the only additional information that would be required is if belt width is inconsistent with structure width.
- Troughing Angle** - What is the angle of the current bed or troughing set?

SIZE	ADJUSTMENT RANGE			
	MIN. DISTANCE		MAX. DISTANCE	
	in.	mm	in.	mm
1	11-3/4	298	14-3/4	375
2	13-3/16	335	17-1/2	445
3	14-1/8	359	19-1/2	495
4	15-15/16	405	23-1/4	591
5	19-9/16	497	30-1/2	775
6	23-13/16	605	38-1/2	978

Refer to the charts for correct size.

NOTE: Based on standard width CEMA troughing idler.

NOTE: For Class B or Class F, please contact Flexco.

CEMA Class C

BELT WIDTH		TROUGH ANGLE		
in.	mm	20°	35°	45°
18	450	SIZE 1*	SIZE 1*	SIZE 1*
24	600	SIZE 1	SIZE 1	SIZE 1
30	750	SIZE 1	SIZE 1	SIZE 2
36	900	SIZE 2	SIZE 2	SIZE 3
42	1050	SIZE 3	SIZE 3	SIZE 4
48	1200	SIZE 3	SIZE 4	SIZE 4
54	1350	SIZE 4	SIZE 4	SIZE 4
60	1500	SIZE 4	SIZE 4	SIZE 5

CEMA Class D

BELT WIDTH		TROUGH ANGLE		
in.	mm	20°	35°	45°
24	600	SIZE 1	SIZE 1	SIZE 1
30	750	SIZE 1	SIZE 2	SIZE 2
36	900	SIZE 2	SIZE 2	SIZE 3
42	1050	SIZE 3	SIZE 3	SIZE 4
48	1200	SIZE 3	SIZE 4	SIZE 4
54	1350	SIZE 4	SIZE 4	SIZE 4
60	1500	SIZE 4	SIZE 4	SIZE 5
72	1800	SIZE 5	SIZE 5	SIZE 6

CEMA Class E

BELT WIDTH		TROUGH ANGLE		
in.	mm	20°	35°	45°
36	900	SIZE 2	SIZE 3	SIZE 3
42	1050	SIZE 3	SIZE 4	SIZE 4
48	1200	SIZE 4	SIZE 4	SIZE 4
54	1350	SIZE 4	SIZE 4	SIZE 4
60	1500	SIZE 5	SIZE 5	SIZE 5
72	1800	SIZE 5	SIZE 5	SIZE 6
84	2100	SIZE 6	SIZE 6	SIZE 6
96	2400	SIZE 6	SIZE 6	SIZE 6

*Mount on the vertical face of the stringer.

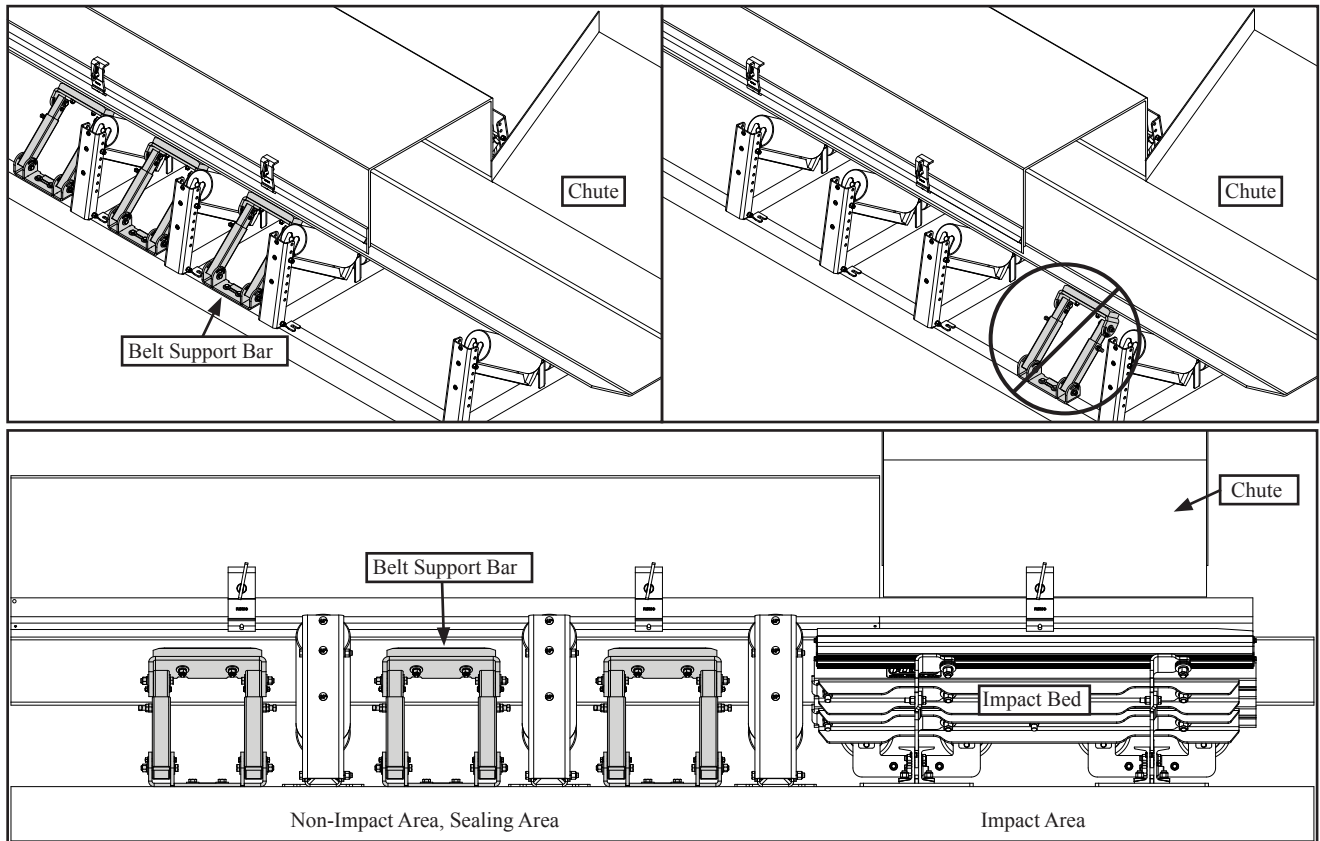

Section 2 - Safety Considerations and Precautions

Before installing and operating the Belt Support Bar, it is important to review and understand the following safety information.

There are set-up, maintenance and operational activities involving both **stationary** and **operating** conveyors. Each case has a safety protocol.

2.1 Stationary Conveyors

The following activities are performed on stationary conveyors:

- Installation
- Bar replacement
- Repairs
- Skirt poly urethane/rubber adjustments
- Cleaning

DANGER

It is imperative that OSHA/MSHA Lockout/Tagout (LOTO) regulations, 29 CFR 1910.147, be followed before undertaking the preceding activities. Failure to use LOTO exposes workers to uncontrolled behavior of the belt cleaner caused by movement of the conveyor belt. Severe injury or death can result.

Before working:

- Lockout/Tagout the conveyor power source
- Disengage any takeups
- Clear the conveyor belt or clamp securely in place

WARNING

Use Personal Protective Equipment (PPE):

- Safety eyewear
- Hardhats
- Safety footwear

Close quarters, springs and heavy components create a worksite that compromises a worker's eyes, feet and skull. PPE must be worn to control the foreseeable hazards associated with conveyor belt cleaners. Serious injuries can be avoided.

2.2 Operating Conveyors

There are two routine tasks that must be performed while the conveyor is running:

- Inspection of the cleaning performance
- Dynamic troubleshooting

DANGER

Every belt cleaner is an in-running nip hazard. Never touch or prod an operating Belt Support Bar. Cleaner hazards cause instantaneous amputation and entrapment.

WARNING

Conveyor chutes contain projectile hazards. Stay as far from the Belt Support Bar as practical and use safety eyewear and headgear. Missiles can inflict serious injury.

WARNING

Never adjust anything on an operating Belt Support Bar. Unforseeable materials falling into the chute can cause violent movements of the Belt Support Bar structure. Flailing hardware can cause serious injury or death.

Section 3 - Pre-Installation Checks and Options

3.1 Checklist

- Check the model and size of the product. Is it the right one for your beltline?
- Check the belt support bar set to be sure all the parts are included in the shipment.
- Find the Information Packet in the shipment.
- Review the “Tools Needed” list on the top of the installation instructions.
- Prepare the conveyor site:
 - Remove the old belt support bar set or impact idlers, if necessary.
 - Inspect the conveyor structure for damage or misalignment. Make adjustments as necessary.
 - Troughing idlers should be installed directly before and after the new belt support bar set.

Section 4 - Installation Instructions

4.1 Belt Support Bar

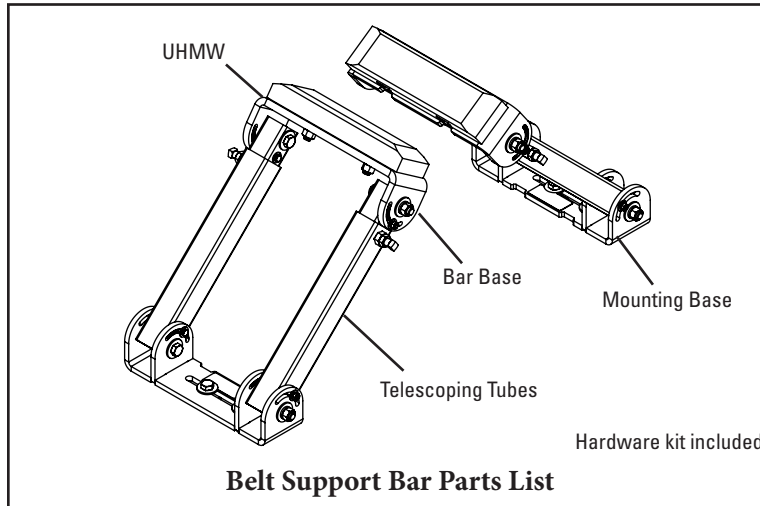

PHYSICALLY LOCK OUT AND TAG THE CONVEYOR AT THE POWER SOURCE BEFORE YOU BEGIN CLEANER INSTALLATION.

- Tools Needed:**
- 7/16" (16mm) Wrench
 - 3/4" (19mm) Wrench
 - OR Large Adjustable/ Crescent Wrenches (x2)
 - Clamps (x2)
 - Drill or torch (as needed)
 - Tape Measure

Before You Begin:

- Open packaging and ensure all items show in the above illustration are present.
- Ensure the Belt Support Bar size you have is the correct version for the belt width and trough angle of your conveyor system.
- Leave unit complete but hardware finger tight to allow rotation and extension of the bases and tubes during installation.

SIZE	ADJUSTMENT RANGE			
	MIN. DISTANCE		MAX. DISTANCE	
	in.	mm	in.	mm
1	11-3/4	298	14-3/4	375
2	13-3/16	335	17-1/2	445
3	14-1/8	359	19-1/2	495
4	15-15/16	405	23-1/4	591
5	19-9/16	497	30-1/2	775
6	23-13/16	605	38-1/2	978

Refer to the charts for correct size.
NOTE: Based on standard width CEMA troughing idler.
NOTE: For Class B or Class F, please contact Flexco.

CEMA Class C

BELT WIDTH		TROUGH ANGLE		
in.	mm	20°	35°	45°
18	450	SIZE 1*	SIZE 1*	SIZE 1*
24	600	SIZE 1	SIZE 1	SIZE 1
30	750	SIZE 1	SIZE 1	SIZE 2
36	900	SIZE 2	SIZE 2	SIZE 3
42	1050	SIZE 3	SIZE 3	SIZE 4
48	1200	SIZE 3	SIZE 4	SIZE 4
54	1350	SIZE 4	SIZE 4	SIZE 4
60	1500	SIZE 4	SIZE 4	SIZE 5

CEMA Class D

BELT WIDTH		TROUGH ANGLE		
in.	mm	20°	35°	45°
24	600	SIZE 1	SIZE 1	SIZE 1
30	750	SIZE 1	SIZE 2	SIZE 2
36	900	SIZE 2	SIZE 2	SIZE 3
42	1050	SIZE 3	SIZE 3	SIZE 4
48	1200	SIZE 3	SIZE 4	SIZE 4
54	1350	SIZE 4	SIZE 4	SIZE 4
60	1500	SIZE 4	SIZE 4	SIZE 5
72	1800	SIZE 5	SIZE 5	SIZE 6

CEMA Class E

BELT WIDTH		TROUGH ANGLE		
in.	mm	20°	35°	45°
36	900	SIZE 2	SIZE 3	SIZE 3
42	1050	SIZE 3	SIZE 4	SIZE 4
48	1200	SIZE 4	SIZE 4	SIZE 4
54	1350	SIZE 4	SIZE 4	SIZE 4
60	1500	SIZE 5	SIZE 5	SIZE 5
72	1800	SIZE 5	SIZE 5	SIZE 6
84	2100	SIZE 6	SIZE 6	SIZE 6
96	2400	SIZE 6	SIZE 6	SIZE 6

*Mount on the vertical face of the stringer.

Section 4 - Installation Instructions

4.1 Belt Support Bar

1. Ensure that there is at least 16" (406mm) between idlers. If not, clear the space for installation.

NOTE: The Belt Support Bar may be installed on a horizontal or vertical surface on the conveyor structure.

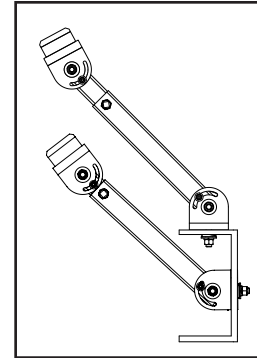
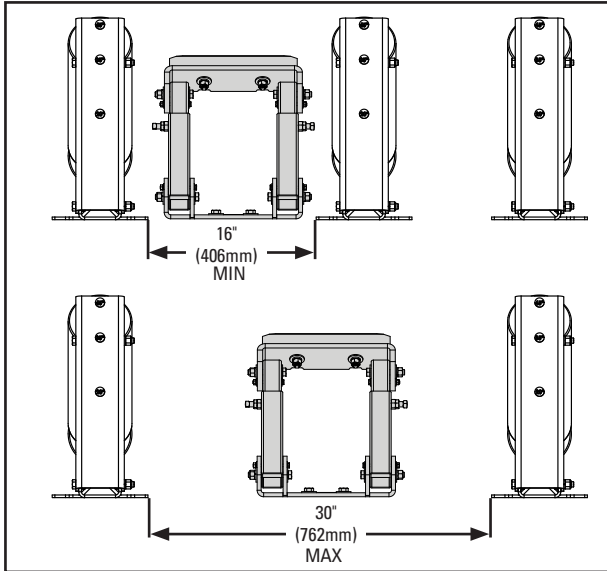

2. Using the mounting base as a template, mark and proceed to burn/drill mounting holes. Mounting holes may already be present on the conveyor structure. Install mounting base and tighten hardware.

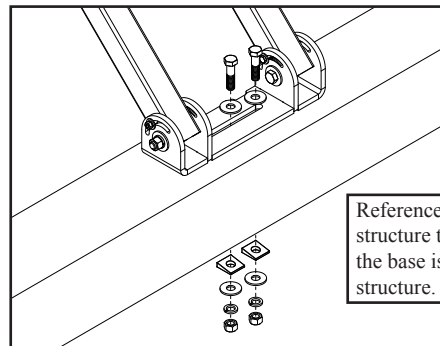
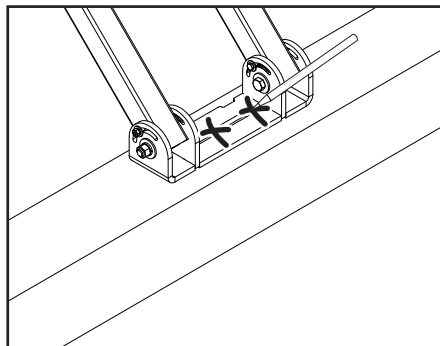

NOTE: Unit may be disassembled at the telescoping tubes for additional ease of installation, but is not necessary. If disassembled, reassemble prior to next step. Do not tighten hardware.

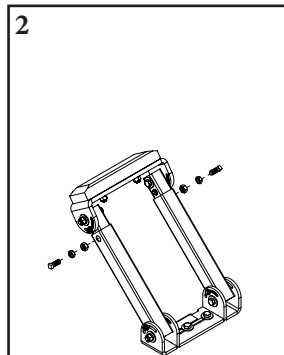
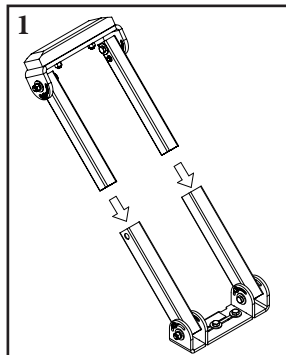

Section 4 - Installation Instructions

3. With the complete assembly in place attached to the structure, extend the UHMW bar/bar base towards the belt, locating it directly under the skirting location, and c-clamp or quick clamp the unit in place.

NOTE: Some upward pressure may be applied to remove any belt sag between idlers. The lift should not take the belt off the leading and trailing idlers.

NOTE: Skirting may be too far in for clamps to work, therefore, hold in place by hand before tightening.

NOTE: Confirm belt makes full contact with the bar.

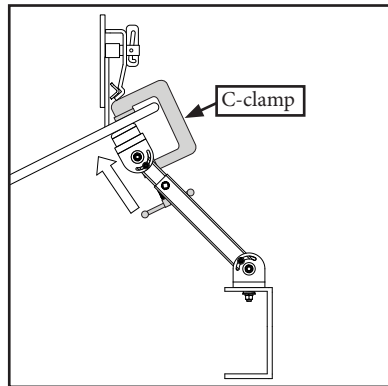

4. Tighten the telescoping tube hardware while the unit is positioned. Proceed to tighten the hardware on the bar base and mounting base to lock in all rotational and extension adjustment.

OPTIONAL: Weld the mounting bracket to the outer tube.

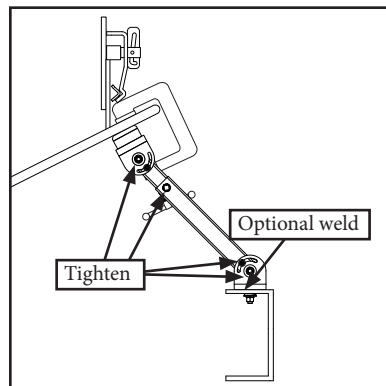

5. Remove c-clamp or quick clamp and check all hardware for tightness. Repeat on opposite side of conveyor.

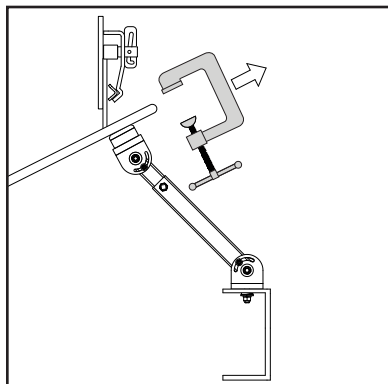

Section 5 - Pre-Operation Checklist and Testing

5.1 Pre-Op Checklist

- Recheck that all fasteners are tightened properly.
- Be sure that all installation materials and tools have been removed from the belt and the conveyor area.

5.2 Test Run the Conveyor

- Run the conveyor for at least 15 minutes and confirm the skirt polyurethane/rubber is properly sealing the transfer point.
- Make adjustments as necessary.

NOTE: Observing the Belt Support Bar when it is running and performing properly will help to detect problems or when adjustments are needed later.

Section 6 - Maintenance

Flexco belt support bars are designed to operate with minimal maintenance. However, to maintain superior performance some service is required. When the belt support bar set is installed a regular maintenance program should be set up. This program will ensure that the belt support bars operate at optimal efficiency, therefore problems can be identified and fixed before any damage is done to the belt, the bed, other conveyor components, or structure.

All safety procedures for inspection of equipment (stationary or operating) must be observed. The Flexco Belt Support Bar operates in the non-impact, sealing area of the load zone of the conveyor system and is in direct contact with the moving belt. Only visual observations can be made while the belt is running. Service tasks can be done only with the conveyor stopped and by observing the correct lockout/tagout procedures.

6.1 New Installation Inspection

After the belt support bars have run for a few days a visual inspection should be made to ensure the bed is performing properly. Make adjustments as needed.

6.2 Routine Visual Inspection (every 2-4 weeks)

A visual inspection of the belt support bars can determine:

- If the skirt polyurethane/rubber is adequately keeping the chute area sealed.
- If the belt support bars are worn out and need to be replaced.
- If there are excessive materials building up around the belt support bars.
- If there is damage to the belt support bars, belt or other conveyor components.

If any of the above conditions exist, a determination should be made on when the conveyor can be stopped for The Flexco Belt Support Bar maintenance.

6.3 Routine Physical Inspection (every 6-8 weeks)

When the conveyor is not in operation and properly locked and tagged out, a physical inspection of the cleaner to perform the following tasks:

- Clean material buildup off the belt support bars and conveyor structure.
- Closely inspect each belt support bar for wear and damage. Bars are worn when the UHMW is worn down to the leading or trailing chamfer.
- Check the belt support bars for damage.
- Inspect all fasteners for tightness and wear. Tighten or replace as needed.
- Inspect skirt polyurethane/rubber and adjust as needed to compensate for impact bar wear.
- When maintenance tasks are completed, test run the conveyor to ensure the belt support bars are performing properly.

Section 6 - Maintenance

6.4 Bar Replacement Instructions

PHYSICALLY LOCK OUT AND TAG THE CONVEYOR AT THE POWER SOURCE BEFORE YOU BEGIN CLEANER INSTALLATION.

1. Loosen the locking bolts.

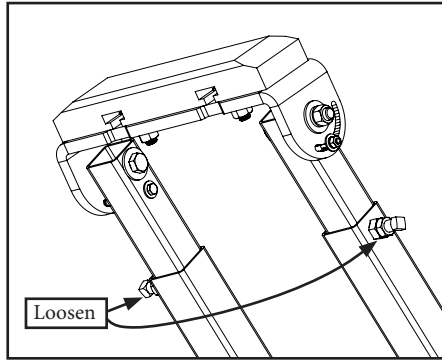

2. Drop the telescoping tubes.

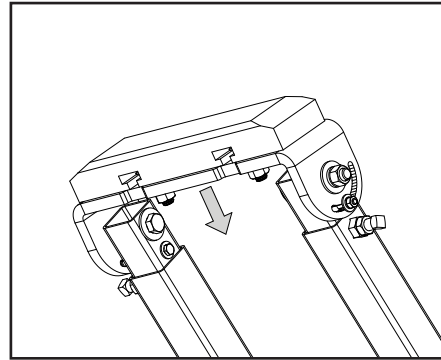

3. Loosen bolts and remove the worn UHMW bar.

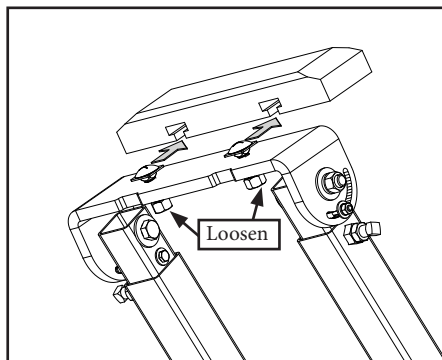

4. Replace the UHMW bar and retighten the bolts.

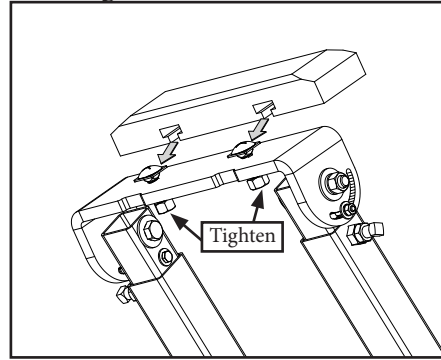

5. Adjust the unit back to position towards the belt, locating it directly under the skirting location, and c-clamp or quick clamp the unit in place.

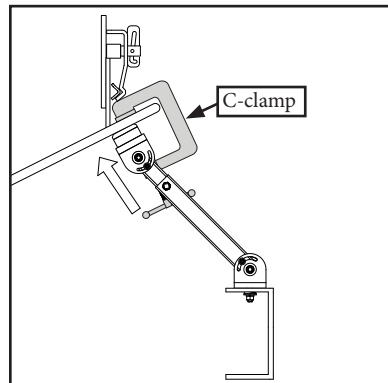

6. Test run the conveyor. Run the conveyor for a few minutes and inspect performance. Make adjustments as necessary.

Section 6 - Maintenance

6.5 Maintenance Log

Conveyor Name/No. _____

Date: _____ Work done by: _____ Service Quote #: _____

Activity: _____

Date: _____ Work done by: _____ Service Quote #: _____

Activity: _____

Date: _____ Work done by: _____ Service Quote #: _____

Activity: _____

Date: _____ Work done by: _____ Service Quote #: _____

Activity: _____

Date: _____ Work done by: _____ Service Quote #: _____

Activity: _____

Date: _____ Work done by: _____ Service Quote #: _____

Activity: _____

Date: _____ Work done by: _____ Service Quote #: _____

Activity: _____

Section 6 - Maintenance

6.6 Maintenance Checklist

Site: _____ Inspected by: _____ +++++ _____ Date: _____

Belt Support Bar: _____ Serial Number: _____

Beltline Information:

Beltline Number: _____ Belt Condition: _____

Belt Width: 18" (450mm) 24" (600mm) 30" (750mm) 36" (900mm) 42" (1050mm) 48" (1200mm) 54" (1350mm) 60" (1500mm) 72" (1800mm) 84" (2100mm) 96" (2400mm)

Transition Distance (back of bed to center of tail pulley): _____ Belt Speed: _____ Belt Thickness: _____

Distance to Leading Idler: _____ Distance to Trailing Idler: _____

Vertical Distance between top of nearest idler and top surface of center impact bars: _____

Impact Bar Life:

Date bars installed: _____ Date bars inspected: _____ Estimated bar life: _____

Bar Condition: _____ Inches (mm) of top cover remaining: _____

Roll Life:

Date rolls installed: _____ Date rolls inspected: _____ Estimated roll life: _____

Roll Condition: _____

Belt Support Bar Condition:

Good Bent Rusted

Overall Belt Support Bar Performance: _____ (Rate the following 1 - 5, 1= very poor - 5 = very good)

Appearance: Comments: _____

Location: Comments: _____

Maintenance: Comments: _____

Performance: Comments: _____

Other comments: _____



Section 7 - Troubleshooting

Problem	Possible Cause	Possible Solutions
Bars wearing out too fast	Bar(s) pushed too far in	Adjust bar to belt, making sure to not deflect too far
	Material off center loading, could lead to belt leaning towards one side	Make sure material is loaded on center of belt and to ensure belt is tracking properly
	Leading idler does not match troughing angle	Correct the idlers to match the troughing angle
Vibration or noise	Belt rubbing too hard on UHMW bar	Verify height of leading/trailing idlers
	Material buildup	Clean up buildup, adjust skirting
	Skirt poly urethane/rubber pushing too hard on belt	Adjust skirt poly urethane/rubber
Bars not in contact with the belt	Shifting during operation or loose bolts	Check tightness of vertical adjusting tubes, if replacing idlers/rollers, adjust belt support bar(s)
Bar damage	Mechanical splice damaging UHMW top covers	Repair, skive or replace splice
Belt stuck on bar	Mistracking	Conveyor adjustments or include mistracking solutions

Section 8 - Specifications and CAD Drawings

8.1 CAD Drawing - Belt Support Bar

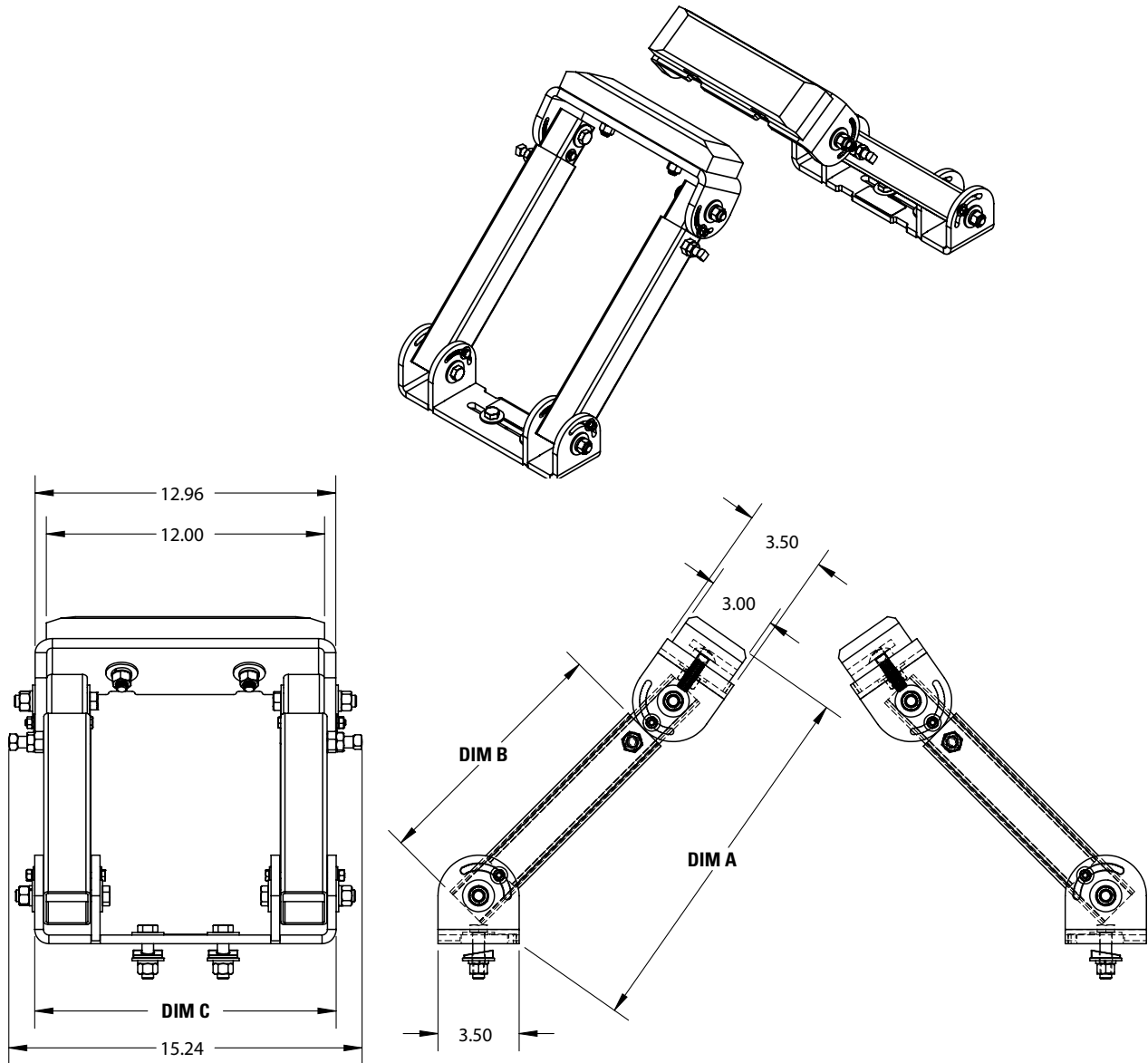

ADJUSTMENT RANGE DIM "A" AT 45°				
SIZE	MIN. DISTANCE		MAX. DISTANCE	
	in.	mm	in.	mm
1	11-3/4	298	14-3/4	375
2	13-3/16	335	17-1/2	445
3	14-1/8	359	19-1/2	495
4	15-15/16	405	23-1/4	591
5	19-9/16	497	30-1/2	775
6	23-13/16	605	38-1/2	978

SIZE	DIM "B"		DIM "C"	
	in.	mm	in.	mm
1	6-1/2	165	13-1/4	337
2	8	203	13-1/4	337
3	9	229	13-1/4	337
4	10-7/8	276	13	330
5	14-1/2	368	13	330
6	18-17/18	481	13	330

Section 9 - Replacement Parts

9.1 Replacement Parts List

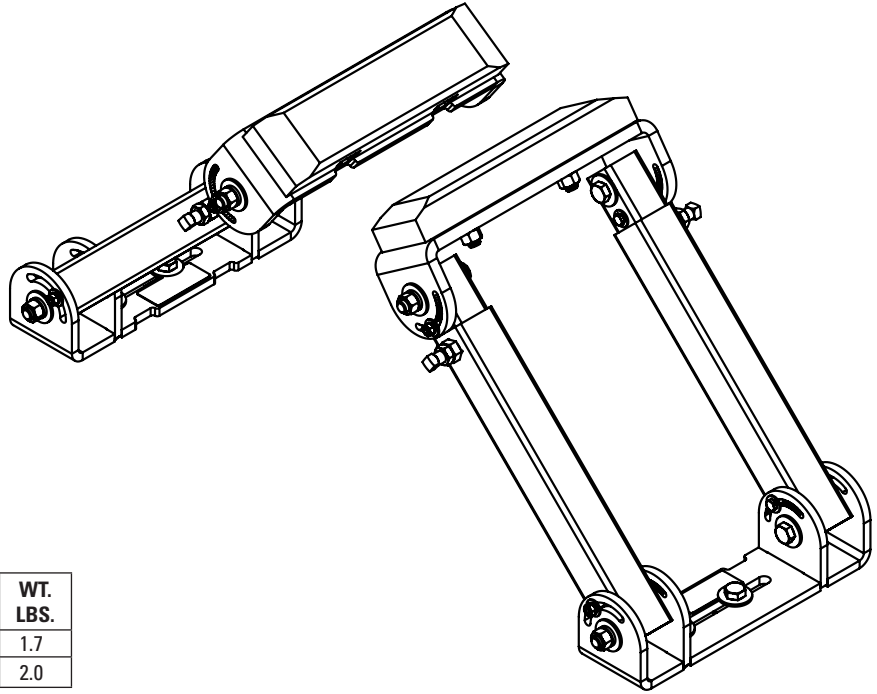

Replacement Parts

REF	DESCRIPTION	ORDERING NUMBER	ITEM CODE	WT. LBS.
1	Bar Replacement	BSB	112960	1.7
2	Bar Replacement Kit	BSB-BRK	112956	2.0

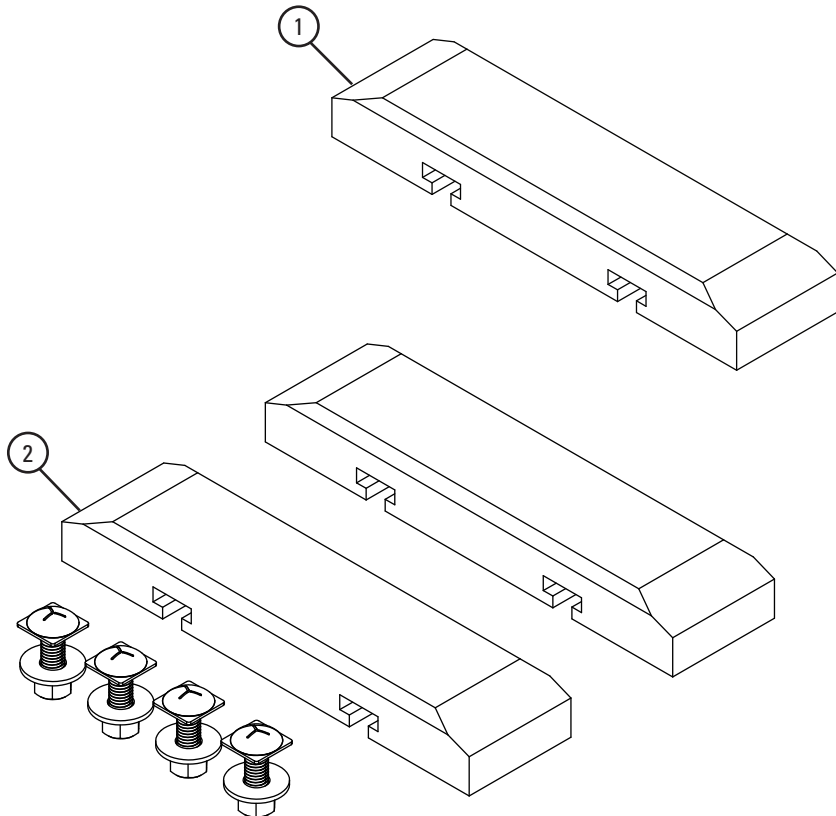

Section 10 – Other Flexco Conveyor Products

Flexco provides many conveyor products that help your conveyors to run more efficiently and safely. These components solve typical conveyor problems and improve productivity. Here is a quick overview on just a few of them:

Flex-Seal™ Skirting System



- Dynamic containment unit that fully seals the loading zone
- Sturdy, corrosion-resistant components that deliver long service life
- Easy to install and maintain
- For skirt poly urethane/rubber 6" (150mm) wide and from 5/16-3/4" (8-19mm) thick

Flex-Lok™ Skirt Clamps

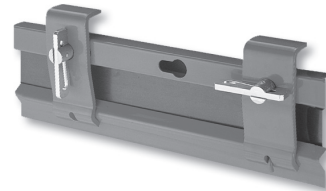

- Eliminates transfer zone spillage
- Interlocking design for easy installation and one person maintenance
- Unique wedge pin holds rubber securely in place and is easy to adjust
- Available in various models and in stainless steel

CBS Belt Cleaner

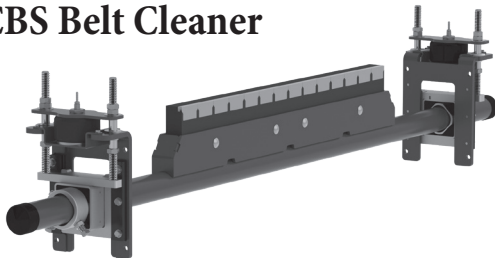

- Thin, hard edge of the metal blade delivers high cleaning efficiency and long wear life.
- Made from heavy-duty, corrosion-resistant steel, available for belt widths from 18 to 96" (450 to 2400mm). Additional sizes are available upon request.
- Flat blade for new or lightly used belts, or curved blade for worn or cupped belts.

DRX™ Impact Beds



- Exclusive Velocity Reduction Technology™ to better protect the belt
- Slide-Out Service™ gives direct access to all impact bars for change-out
- Impact bar supports for longer bar life
- 4 models to custom fit to the application

Flexco Specialty Belt Cleaners



- "Limited space" cleaners for tight conveyor applications
- High Temp cleaners for severe, high heat applications
- A rubber fingered cleaner for chevron and raised rib belts
- Multiple cleaner styles in stainless steel for corrosive applications

Belt Plows



- A belt cleaner for the tail pulley
- Exclusive blade design quickly spirals debris off the belt
- Economical and easy to service
- Available in vee or diagonal models

Visit www.flexco.com for other Flexco locations and products, or to find an authorized distributor.

©2024 Flexible Steel Lacing Company. 10-01-24. 112958

