

# ROTATIONAL BRACKET

## Instructions for Installation

Reference Segmented Transfer Plate (STP) installation manual (X4064) for full installation details. This sheet is intended to guide the installation of the rotational bracket (111858).

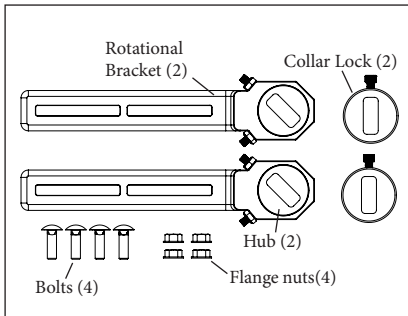

Rotational Bracket (Kit 111858)

Note: Thread-locking fluid should be applied to screws.

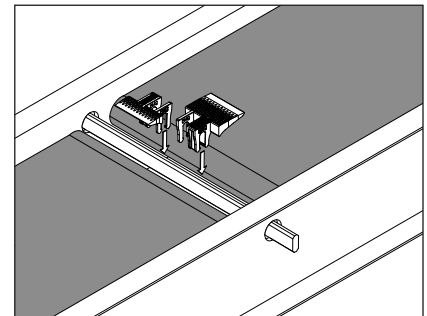
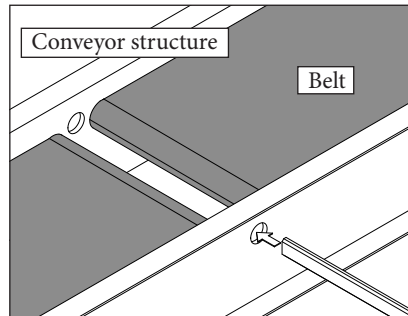

1. Use the STP Gage to approximate the bar position and mark the center on both sides of the conveyor structure. Drill or cut a 1.5" (38mm) diameter hole through each conveyor wall, aligning the holes perpendicular to the conveyor belt. Slide the STP mount bar through each hole.

2. Install the segments onto the bar across the width of the conveyor. Reference installation manual X4064 for full installation details.

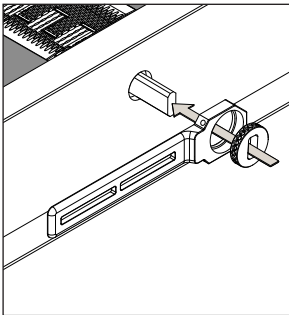

3. Attach rotational bracket and hub to the bar.

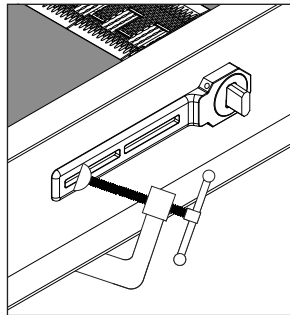

4. Position rotational bracket into desired installation position and clamp to the conveyor structure. Repeat for each side of the conveyor.

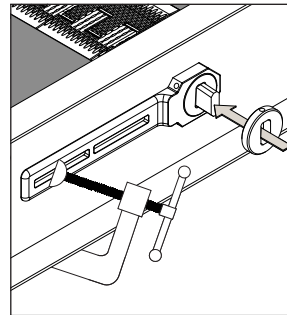

5. Slide the collar lock onto the bar. Repeat for each side of the conveyor.

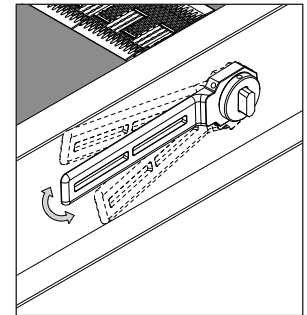

6. Finalize bracket orientation.

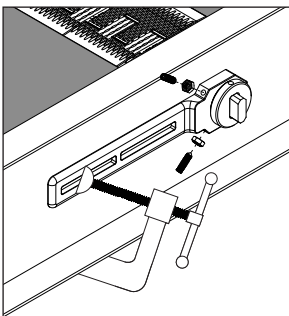

7. Secure the hub to the rotational bracket with set screws included. Repeat for each side of the conveyor.

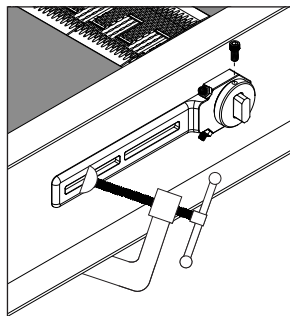

8. Secure the collar lock using the socket head screw included. Repeat for each side of the conveyor.

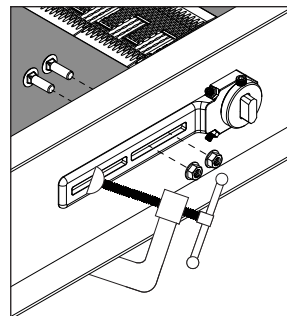

9. Fasten the bracket to the conveyor structure using the included bolts and washers, transferring drilling as required prior to removing the clamps.

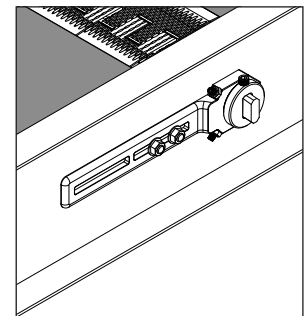

10. Remove clamps from the conveyor structure.

Visit [www.flexco.com](http://www.flexco.com) for other Flexco locations and products, or to find an authorized distributor.