

# CFC Secondary Cleaner

---

## Installation, Operation and Maintenance Manual

---



## CFC Secondary Cleaner

---

Serial Number:	_____
Purchase Date:	_____
Purchased From:	_____
Installation Date:	_____

The serial number can be found on the serial number label, which comes as part of the information pack included in the box containing the belt cleaner.

This information is helpful with future inquiries or queries regarding spare parts and technical data as well as for troubleshooting.

# Table of Contents

---

<b>Section 1 - Important Information .....</b>	<b>4</b>
1.1 General Introduction.....	4
1.2 User Benefits .....	4
1.3 Service Option.....	4
<b>Section 2 - Safety Considerations and Precautions .....</b>	<b>5</b>
2.1 Stationary Conveyors.....	5
2.2 Operating Conveyors.....	5
<b>Section 3 - Pre-Installation Checks and Options.....</b>	<b>6</b>
3.1 Checklist.....	6
<b>Section 4 - Installation Instructions.....</b>	<b>7</b>
4.1 CFC Secondary Cleaner .....	7
<b>Section 5 - Pre-Operation Checklist and Testing.....</b>	<b>10</b>
5.1 Pre-Op Checklist.....	10
5.2 Test Run the Conveyor .....	10
<b>Section 6 - Maintenance.....</b>	<b>11</b>
6.1 New Installation Inspection.....	11
6.2 Routine Visual Inspection.....	11
6.3 Routine Physical Inspection .....	11
6.4 Maintenance Log.....	12
<b>Section 7 - Troubleshooting .....</b>	<b>13</b>

# Section 1 - Important Information

---

## 1.1 General Introduction

We at Flexco are very pleased that you have selected a CFC Secondary Cleaner for your conveyor system.

This manual will help you to understand the operation of this product and assist you in making it work up to its maximum efficiency over its lifetime of service.

It is essential for safe and efficient operation that the information and guidelines presented be properly understood and implemented. This manual will provide safety precautions, installation instructions, maintenance procedures and troubleshooting tips.

If, however, you have any questions or problems that are not covered, please contact your field representative or our Customer Service Department.

**Visit [www.flexco.com](http://www.flexco.com) for other Flexco locations and products.**

Please read this manual thoroughly and pass it on to any others who will be directly responsible for installation, operation and maintenance of this product. While we have tried to make the installation and service tasks as easy and simple as possible, **it does however require correct installation and regular inspections and adjustments to maintain top working condition.**

## 1.2 User Benefits

Correct installation and regular maintenance will provide the following benefits for your operation:

- Reduced conveyor downtime
- Reduced man-hour labor
- Lower maintenance budget costs
- Increased service life for the belt cleaner and other conveyor components

## 1.3 Service Option

The CFC Secondary Cleaner is designed to be easily installed and serviced by your on-site personnel. However, if you would prefer complete turn-key factory service, please contact your local Flexco Field Representative.

# Section 2 - Safety Considerations and Precautions

---

Before installing and operating the CFC Secondary Cleaner, it is important to review and understand the following safety information.

There are set-up, maintenance and operational activities involving both **stationary** and **operating** conveyors. Each case has a safety protocol.

---

## 2.1 Stationary Conveyors

The following activities are performed on stationary conveyors:

- Installation
- Drum replacement
- Repairs
- Tension adjustments
- Cleaning

### **DANGER**

It is imperative that OSHA/MSHA Lockout/Tagout (LOTO) regulations, 29 CFR 1910.147, be followed before undertaking the preceding activities. Failure to use LOTO exposes workers to uncontrolled behavior of the belt cleaner caused by movement of the conveyor belt. Severe injury or death can result.

Before working:

- Lockout/Tagout the conveyor power source
- Disengage any takeups
- Clear the conveyor belt or clamp securely in place

### **WARNING**

Use Personal Protective Equipment (PPE):

- Safety eyewear
- Hardhats
- Safety footwear

Close quarters, springs and heavy components create a worksite that compromises a worker's eyes, feet and skull. PPE must be worn to control the foreseeable hazards associated with conveyor belt cleaners. Serious injuries can be avoided.

---

## 2.2 Operating Conveyors

There are two routine tasks that must be performed while the conveyor is running:

- Inspection of the cleaning performance
- Dynamic troubleshooting

### **DANGER**

Every belt cleaner is an in-running nip hazard. Never touch or prod an operating cleaner. Cleaner hazards cause instantaneous amputation and entrapment.

### **WARNING**

Belt cleaners can become projectile hazards. Stay as far from the cleaner as practical and use safety eyewear and headgear. Missiles can inflict serious injury.

### **WARNING**

Never adjust anything on an operating cleaner. Unforeseeable belt projections and tears can catch on cleaners and cause violent movements of the cleaner structure. Flailing hardware can cause serious injury or death.

## Section 3 - Pre-Installation Checklist

---

### 3.1 Checklist

**Please note: The cleat height must not exceed 32mm (1-1/4").**

- Check that the cleaner size is correct for the beltline width.
- Check the belt cleaner carton and make sure all parts are included
- Review the "Tools Needed" list on the top of the installation instructions
- Check the conveyor site:
  - Will the cleaner be installed on a chute?
  - Will it be installed on an open head pulley, for which a mounting plate is required?

# Section 4 - Installation Instructions

## 4.1 CFC Secondary Cleaner

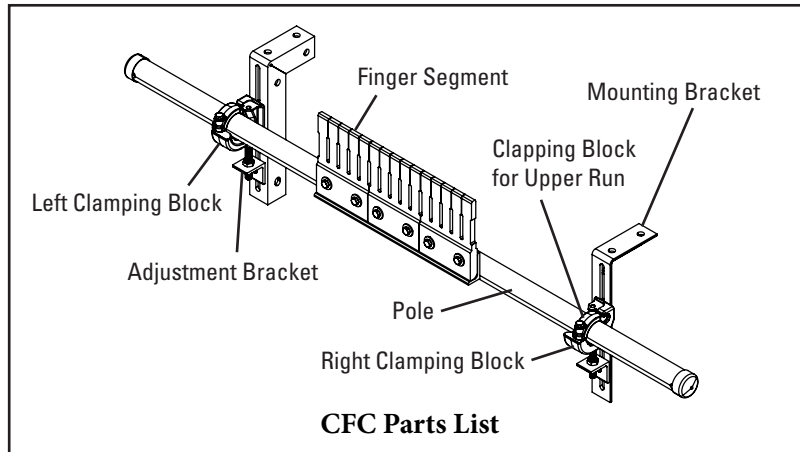

**PHYSICALLY LOCK OUT AND TAG THE CONVEYOR AT THE POWER SOURCE BEFORE YOU BEGIN CLEANER INSTALLATION.**

### Tools Needed:

- 19mm (3/4") Wrench
- 12mm (1/2") Wrench
- Ratchet With 19mm (3/4") Socket
- (2) 152mm (6") C-Clamps (for temporary positioning of mounting brackets)
- Tape Measure
- Cutting Torch and/or Welder
- Marking Pen

### Before Installation:

- For chute mounting it may be necessary to cut an access hole to allow for installation and inspections.
- Follow all safety precautions when using a cutting torch.
- If welding, protect all fastener threads from weld spatter.

### Selecting the Installation Site:

- If the conditions permit, mount the clamping system directly onto the structure. Ensure the mounting area is rigid and able to handle vibrations associated with the belt cleaner.

### 1. Install mounting brackets.

Determine the correct clamp block (left or right) and bracket needed for each side of the conveyor (Fig. 1). The top strap should be offset away from the belt (notch should be visible from the outside of the conveyor for the top strap).

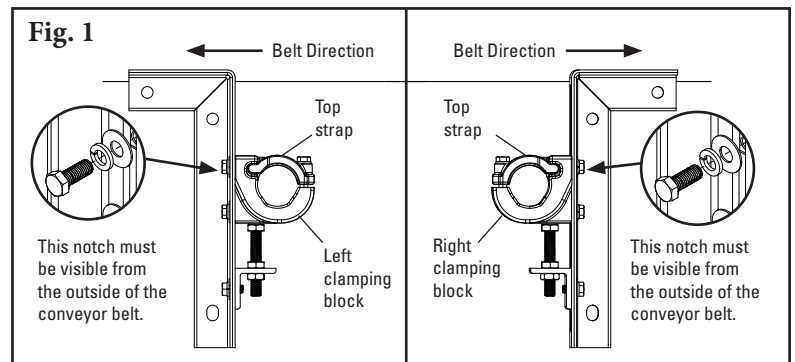

## Section 4 - Installation Instructions

### 4.1 CFC Secondary Cleaner

- Choose the tensioner position.** The tensioner is shipped mounted in the push-up position. Depending upon the space constraints of the installation, the tensioner can be optionally mounted in a pull-up position. To do this, loosen the threaded rod lock nut, unscrew the threaded rod and remove adjusting bracket lock bolt. Then move the adjusting bracket and threaded rod to the top of the clamp blocks (Fig. 2) and tighten threaded rod lock nut.
- Positioning of the belt cleaner is either directly on the head pulley, 200mm (8") after the head pulley, or 200mm (8") ahead of or behind an additional pressure roller (Fig. 3).

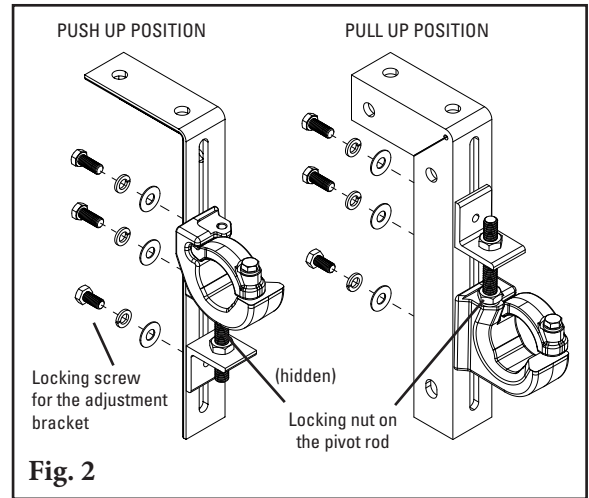

- Clamp the mounting bracket into position** (use screw clamps). Move the clamp block to align the center of the block with a point 237mm (9-5/16") below the belt (Fig. 4). To move the clamp blocks, if necessary, loosen the clamp block lock bolts and the adjusting bracket lock bolt and turn the adjusting bolt jam nuts. The bracket can now be bolted or welded in place. Locate and install bracket on the opposite side of belt in alignment with the first bracket.

**NOTE:** The brackets must be aligned perpendicular to the belt.

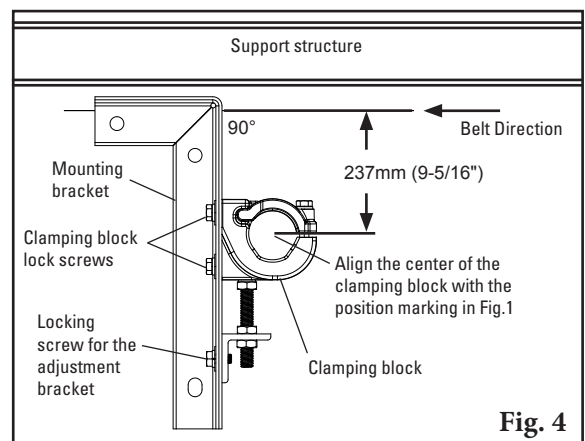
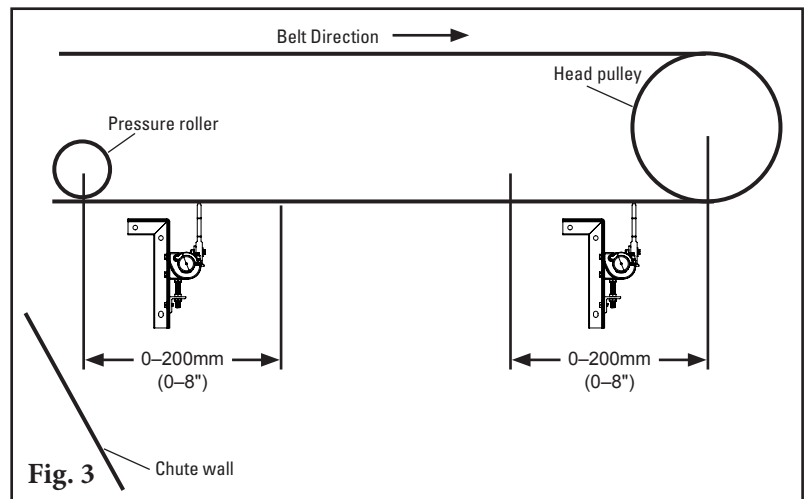



## Section 4 - Installation Instructions

### 4.1 CFC Secondary Cleaner

- 5. Install the pole.** Remove the clamp block top strap on the access side of the conveyor, and the opposite side, loosen the clamp block bolt. Next, slide the pole across and into the loosened clamp block, place near end of pole in bottom section of clamp block (Fig. 5). Replace the top strap on the clamp block, center the blades on the belt and tighten both clamp block bolts finger tight.
- 6. Set the tip angle and tension.** The fingers will be aligned perpendicular/right angle to the belt. Lock the pole in place by tightening the clamping block screws evenly. Adjust the cleaner vertically until making contact with the belt. Make a mark on the mounting bracket and clamping block on both tensioners. Adjust the cleaner 25mm (1") vertically. Tighten all clamp block lock bolts. Double check that all bolts and nuts on the cleaner are tight (Fig. 6).

#### Test run the cleaner and inspect its performance.

If vibration occurs or more cleaning efficiency is desired, increase the tip tension by making a 1/4 turn adjustment on each adjusting bolt.

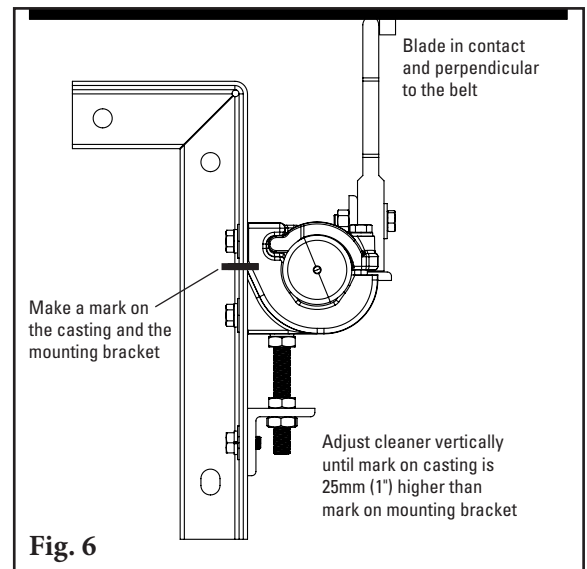
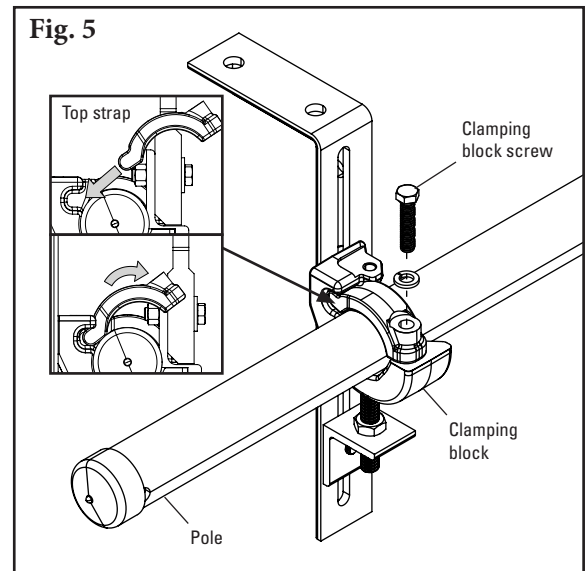

## Section 5 - Pre-Operation Checklist and Testing

---

### 5.1 Pre-Op Checklist

- Clean segments in their entirety if necessary.
- Recheck that all fasteners are tightened properly.
- Add pole caps.
- Check the contact pressure between blades and belt, depending on effectiveness of cleaning
- Apply all supplied labels to the cleaner.
- Check the blade location on the belt.
- Be sure that all installation materials and tools have been removed from the belt and the conveyor area.

### 5.2 Test Run the Conveyor

- Run the conveyor for at least 15 minutes and inspect the cleaning performance.
- Make adjustments as necessary.

**NOTE:** Observing the cleaner when it is running and performing properly will help to detect problems or when adjustments are needed later.

Maintenance carried out in line with maintenance specifications ensures that the belt is cleaned optimally, maintains the cleaning function of the belt cleaner, and ensures a long service life.

## Section 6 - Maintenance

---

Flexco belt cleaners are designed to operate with minimum maintenance. However, to maintain superior performance some service is required. When the cleaner is installed a regular maintenance program should be set up. This program will ensure that the cleaner operates at optimal efficiency and problems can be identified and fixed before the cleaner stops working.

All safety procedures for inspection of equipment (stationary or operating) must be observed. The CFC Secondary Cleaner operates at the discharge end of the conveyor and is in direct contact with the moving belt. Only visual observations can be made while the belt is running. Service tasks can be done only with the conveyor stopped and by observing the correct lockout/tagout procedures.

### 6.1 New Installation Inspection

After the belt cleaner has been in use for 5 days, a visual inspection should take place to ensure that it is working properly. Adjustments should be carried out as required.

### 6.2 Regular Visual Inspection (every 2-4 weeks)

A visual inspection of the cleaner and belt should look for:

- If adjusting brackets are set for optimal tensioning.
- If the belt looks clean or if there are areas that are dirty.
- If the blades are worn out and need to be replaced.
- If there is damage to the blades or other cleaner components.
- If fugitive material is built up on the cleaner or in the transfer area.
- If there is cover damage to the belt.
- If there is vibration or bouncing of the cleaner on the belt.
- If a snub pulley is used, a check should be made for material buildup on the pulley.
- Significant signs of carryback.
- If any of the above conditions exist, a determination should be made on when the conveyor can be stopped for cleaner maintenance.

### 6.3 Routine Physical Inspection (every 6-8 weeks)

When the conveyor is not in operation and properly locked and tagged out a physical inspection of the cleaner to perform the following tasks:

- Clean material buildup off of the cleaner blade and pole.
- Closely inspect the blades for wear and any damage. Replace if needed.
- Ensure full blade to belt contact.
- Inspect the cleaner pole for damage.
- Inspect all fasteners for tightness and wear. Tighten or replace as needed.
- Replace any worn or damaged components.
- Check the tension of the cleaner blade to the belt.
- When maintenance tasks are completed, test run the conveyor to ensure the cleaner is performing properly.

# Section 6 - Maintenance

---

## 6.4 Maintenance Log

Conveyor Name/No. \_\_\_\_\_

Date: \_\_\_\_\_ Work done by: \_\_\_\_\_ Service Quote #: \_\_\_\_\_

Activity: \_\_\_\_\_

---

Date: \_\_\_\_\_ Work done by: \_\_\_\_\_ Service Quote #: \_\_\_\_\_

Activity: \_\_\_\_\_

---

Date: \_\_\_\_\_ Work done by: \_\_\_\_\_ Service Quote #: \_\_\_\_\_

Activity: \_\_\_\_\_

---

Date: \_\_\_\_\_ Work done by: \_\_\_\_\_ Service Quote #: \_\_\_\_\_

Activity: \_\_\_\_\_

---

Date: \_\_\_\_\_ Work done by: \_\_\_\_\_ Service Quote #: \_\_\_\_\_

Activity: \_\_\_\_\_

---

Date: \_\_\_\_\_ Work done by: \_\_\_\_\_ Service Quote #: \_\_\_\_\_

Activity: \_\_\_\_\_

---

Date: \_\_\_\_\_ Work done by: \_\_\_\_\_ Service Quote #: \_\_\_\_\_

Activity: \_\_\_\_\_

---

Date: \_\_\_\_\_ Work done by: \_\_\_\_\_ Service Quote #: \_\_\_\_\_

Activity: \_\_\_\_\_

---

Date: \_\_\_\_\_ Work done by: \_\_\_\_\_ Service Quote #: \_\_\_\_\_

Activity: \_\_\_\_\_

## Section 7 - Troubleshooting

If a malfunction occurs on the belt cleaner, the following instructions must be followed:

<b>Problem</b>	<b>Possible Cause</b>	<b>Possible Solutions</b>
Material passing cleaner	Segments are not inserted properly (too tight or too loose)	Correct the contact pressure
Segments do not touch the belt	Check the installation in accordance with the operating instructions	Check if the belt cleaner rotates freely
Damaged or worn segments	Cleaner being overburdened	Replace with new segments
Dirty segments or belt cleaner	Material buildup	Clean segments and belt cleaner
Quick-release pole not at correct angle to the system	Cleaner not set up correctly	Ensure cleaner set up properly
		Check the position of the mounting brackets and pole along with segments
Uneven contact between individual segments and conveyor	Cleaner not set up correctly or dirty	Loosen the belt cleaner, clean segments, retighten the belt cleaner
Due to uneven distribution of material on conveyor belt, or uneven wear and tear on belt, uneven wear of segments is noticed	Cleaner fingers worn/damaged	This is normal; segments should be replaced periodically

Ice and snow should be removed from the belt cleaner in winter and a check should be made before work starts to ensure no malfunctions are present. The Flexco CFC Secondary Cleaner requires special maintenance in winter (more often than mentioned in point 6.2). These preventative measures help protect the conveyor belt from damage between successive starts of the system, e.g. against the material freezing over.

Visit [www.flexco.com](http://www.flexco.com) for other Flexco locations and products, or to find an authorised distributor.

©2023 Flexible Steel Lacing Company. 07-03-24. 108514

