

# Belt Edge Protector (BEP)

---

## Installation, Operation & Maintenance Manual

---



Patents: [www.flexco.com/patents](http://www.flexco.com/patents)

[www.flexco.com](http://www.flexco.com)



# (BEP) - Belt Edge Protector

---

|                    |       |
|--------------------|-------|
| Ordering Number:   | _____ |
| Installation Date: | _____ |
| Purchase Date:     | _____ |
| Purchased From:    | _____ |

This information will be helpful for any future inquiries or questions about BEP replacement parts, specifications, or troubleshooting.

# Table of Contents

---

|  |            |
|--|------------|
| <b>Section 1 - Important Information .....</b>                 | <b>4</b>   |
| 1.1 Introduction.....  | 4          |
| 1.2 User Benefits .....  | 4          |
| 1.3 Service Option.....  | 4          |
| <b>Section 2 - Safety Considerations and Precautions .....</b> | <b>5</b>   |
| 2.1 Stationary Conveyors .....                                 | 5          |
| 2.2 Operating Conveyors.....                                   | 5          |
| <b>Section 3 - Pre-Installation Checks and Options .....</b>   | <b>6</b>   |
| 3.1 Checklist.....   | 6          |
| 3.2 Conveyor Mounting Structure .....                          | 6          |
| <b>Section 4 - Installation Instructions .....</b>             | <b>7-9</b> |
| 4.1 BEP Belt Edge Protector Installation Instructions .....    | 7-9        |
| <b>Section 5 - Pre-Operation Checklist and Testing .....</b>   | <b>10</b>  |
| 5.1 Pre-Op Checklist.....                                      | 10         |
| 5.2 Test Run the Conveyor .....                                | 10         |
| <b>Section 6 - Maintenance .....</b>                           | <b>10</b>  |
| 6.1 New Installation Inspection.....                           | 10         |
| 6.2 Routine Visual Inspection.....                             | 10         |
| 6.3 Routine Physical Inspection .....                          | 11         |
| 6.4 Cleaning Instructions .....                                | 11         |
| 6.5 Wear Inspection .....                                      | 11         |
| 6.6 Segment Replacement Instructions .....                     | 11         |
| 6.7 Maintenance Log.....                                       | 12         |
| 6.8 Maintenance Checklist .....                                | 13         |
| <b>Section 7 - Troubleshooting .....</b>                       | <b>14</b>  |
| <b>Section 8 - Specifications.....</b>                         | <b>15</b>  |
| <b>Section 9 - Replacement Parts.....</b>                      | <b>15</b>  |

# Section 1 – Important Information

---

## 1.1 Introduction

We at Flexco are very pleased that you have selected the Belt Edge Protector (BEP) for your conveyor system.

This manual will help you to understand the operation of this product and assist you in making it work up to its maximum efficiency over its lifetime of service.

It is essential for safe and efficient operation that the information and guidelines presented here be properly understood and implemented. This manual will provide safety precautions, installation instructions, maintenance procedures and troubleshooting tips.

If you have any questions or problems that are not covered in this manual, please visit our web site or contact our Customer Service Department:

**Customer Service: 1-800-541-8028**

**Visit [www.flexco.com](http://www.flexco.com) for other Flexco locations and products.**

Please read this manual thoroughly and pass it on to any others who will be directly responsible for installation, operation, and maintenance of this product. While we have tried to make the installation and service tasks as simple as possible, it does require correct installation and regular inspections to maintain top performance.

## 1.2 User Benefits

Correct installation and regular maintenance will provide the following benefits for your operation:

- Reduced conveyor downtime
- Reduced man-hour labor
- Lower maintenance costs
- Increased service life for the Belt Edge Protector and other conveyor components

## 1.3 Service Option

The BEP Belt Edge Protector is designed to be easily installed and serviced by your on-site personnel. However, if you would prefer complete turn-key factory service, please contact your local Flexco Territory Manager or your Flexco Distributor.

# Section 2 – Safety Considerations and Precautions

## 2.1 Stationary Conveyors

Before installing and operating the Belt Edge Protector, it is important to review and understand the following safety information. There are set-up, maintenance, and operational activities involving both **stationary** and **operating** conveyors. Each case has a safety protocol.

The following activities are performed on stationary conveyors:

- Installation
- Protector replacement
- Repairs
- Position adjustments
- Cleaning

### **DANGER**

It is imperative that OSHA Lockout/Tagout (LOTO) regulations, 29 CFR 1910.147, be followed before undertaking the preceding activities. Failure to use LOTO exposes workers to uncontrolled behavior of the Belt Edge Protector caused by movement of the conveyor belt. Severe injury or death can result.

#### **Before working:**

- Lockout/Tagout the conveyor power source
- Disengage any takeups
- Clear the conveyor belt or clamp securely in place

### **WARNING**

#### **Use Personal Protective Equipment (PPE):**

- Safety eyewear
- Hardhats
- Safety footwear
- Gloves (especially when welding)

Close quarters, springs, and heavy components create a worksite that compromises a worker's eyes, feet, and skull. PPE must be worn to control the foreseeable hazards associated with conveyor maintenance. Serious injuries can be avoided.

## 2.2 Operating Conveyors

There are two routine tasks that must be performed while the conveyor is running:

- Inspection of the product performance
- Dynamic troubleshooting

### **DANGER**

Every belt protector is an in-running nip hazard. Never touch or prod an operating protector. Protector hazards can cause instantaneous amputation and entrapment.

### **WARNING**

Belt protectors can become projectile hazards. Stay as far from the product as practical and use safety eyewear and headgear. Missiles can inflict serious injury.

### **WARNING**

Never adjust anything on an operating protector. Unforeseeable belt projections and tears can catch on protectors and cause violent movements of the protector or structure. Flailing hardware can cause serious injury or death.

## Conditions of Incorporation - Residual Risk Remaining

This product is not intended to be interacted with by personnel while the conveyor is operating or while in a non-lock out state. Serious injury may occur.

All potential draw-in or entanglement hazards & other entanglement opportunities must be addressed in the final integrated system. Risk assessment of the completed system where this product is incorporated must be evaluated, particularly for public settings.

## Section 3 – Pre-installation Checks and Options

---

This section will address the proper selection of the Belt Edge Protector (BEP). It is important that you determine the location and required length of the product so you can properly install the Flexco Belt Edge Protector (BEP). Failure to follow this procedure will result in deficient product performance.

### 3.1 Checklist

- Check the Belt Edge Protector Kit and make sure all the parts are included.
- Review the “Tools Needed” list at the top of the installation instructions.
- Inspect the belt and splice(s) for damage (tears, gouges, raised splices, etc.) that may interfere with the Belt Edge Protector.
- Belt Edge Protectors are not recommended for use on cleated belts.
- Check for obstructions that may require Protector adjustments or modifications.
- Chute lip must maintain 2" lip for BEP to work correctly. This product should not be installed if lip is less than 2"

**CAUTION:** All parts of the Belt Edge Protector must be firmly attached to the belt conveyor structure and be properly bolted, or anchored in compliance with your company’s policies, specifications, and any applicable legal or regulatory requirements prior to installation and use.

### 3.2 Note on Drilling through Stainless

For systems with stainless steel side walls, it is crucial to follow best practices when drilling through stainless steel to ensure a smooth installation process. These practices have been found effective and include the following steps:

- Prior to drilling, use a center punch to mark the precise location of the hole. This helps to create a small indentation that guides the drill bit and prevents it from wandering.
- Select the appropriate drill bit material for stainless steel, such as high-speed steel (HSS) or cobalt drill bits. Cobalt drill bits are especially recommended for their enhanced durability and ability to withstand the hardness of stainless steel.
- Apply cutting fluid or lubricant, throughout the drilling process to reduce heat buildup and friction. This helps extend the life of the drill bit and prevents damage to the workpiece. Ensure that the lubricant is applied frequently.
- Secure the stainless-steel workpiece firmly in place using clamps or other appropriate methods to prevent movement during drilling. This ensures both accuracy and safety during the process.
- Start by drilling a small pilot hole using a smaller diameter drill bit. This serves as a guide for the larger drill bit and minimizes the risk of slipping or wandering.
- Gradually increase the drill bit size, moving from smaller to larger diameter bits. This approach reduces stress on the drill bit and minimizes the chances of breakage or getting stuck.
- Use a slow drilling speed suitable for stainless steel. Applying steady and constant pressure to the drill bit, ensure that you do not push too hard or use excessive force, as it can lead to overheating or breakage.
- Monitor the temperature of the drill bit during drilling. If it becomes too hot, pause and cool it down using a coolant or by dipping it in water. This prevents the drill bit from losing its temper and becoming dull.
- Periodically remove chips and debris from the hole to avoid accumulation that can cause binding or overheating of the drill bit.

Adhere to the safety precautions by wearing appropriate personal protective equipment (PPE) such as safety glasses, gloves, and ear protection. Stainless steel can produce sharp edges and flying debris during drilling, so safety is paramount. Please consult the manufacturer's instructions for your specific drill and follow their recommendations while drilling. For additional drill bits, you may consider purchasing the Flexco Belt Edge Protector Installation Kit.

# Section 4 - Installation Instructions

---

## 4.1 Tools Required for Installation

### Tools Required

1/4" shims

7/16" wrench (available in Install Kit)

1/4" drill bit (standard and cobalt) (available in Install Kit)

5/8" counterbore drill bit (available in Install Kit)

Drill Driver

Handheld Band Saw or Hack Saw equipped for metal and plastic cutting

### Optional Tools

5/32" ball end driver/Allen wrench

Extended Bit holder

### Hardware Required (Included in each BEP Kit)

1/4-20 x 1.00" BHS

1/4-20 Nylock Nut

1/4" Flat Washer

## Section 4 - Installation Instructions - BEP (cont.)

### Installation Instructions

- 1** Place at least (2) 1/4" shims on conveyor belt and place Belt Edge Protector on top. Shims should be spaced apart, one directly aligned with the hole being drilled and at least one other near the furthest end of the Belt Edge Protector. Belt Edge Protector should be installed with nominal 1/4" gap to the top of the belt.

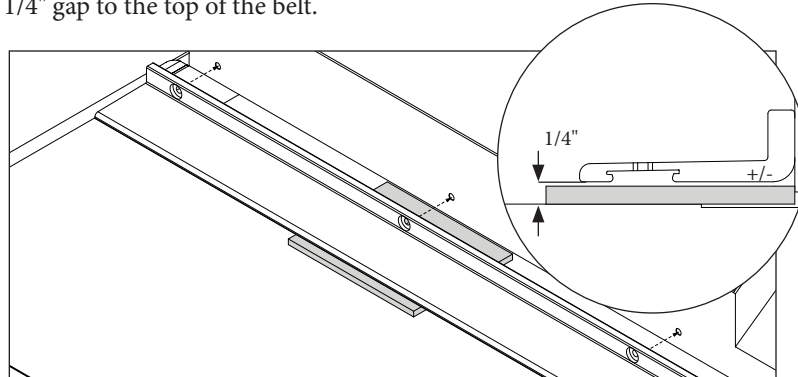

**NOTICE:** For best results, place the first Belt Edge Protector at the start of the conveyor belt and add segments until there are Belt Edge Protector segments installed along both sides of the entire length of the conveyor. Chute lip must maintain 2" height for BEP to work correctly. This product should not be installed if there is less than 2".

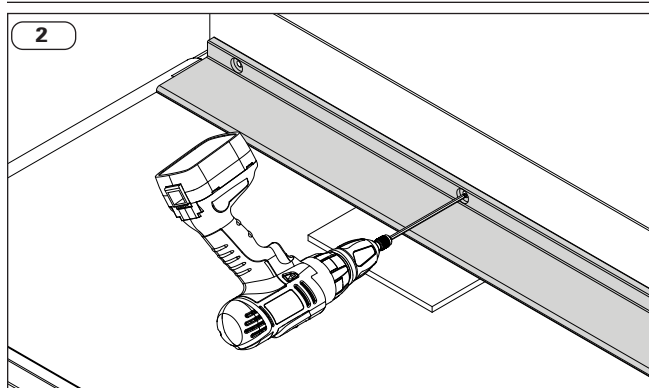
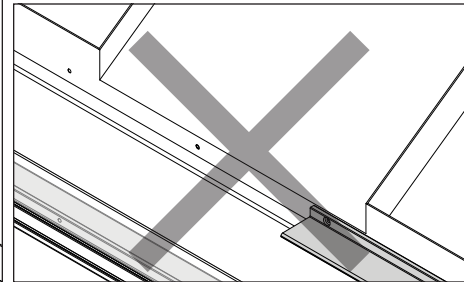
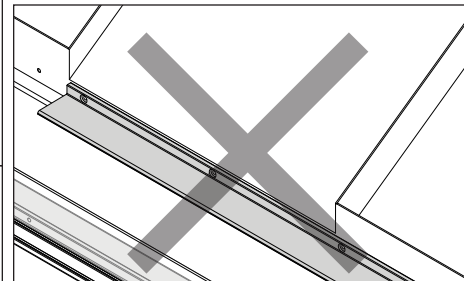
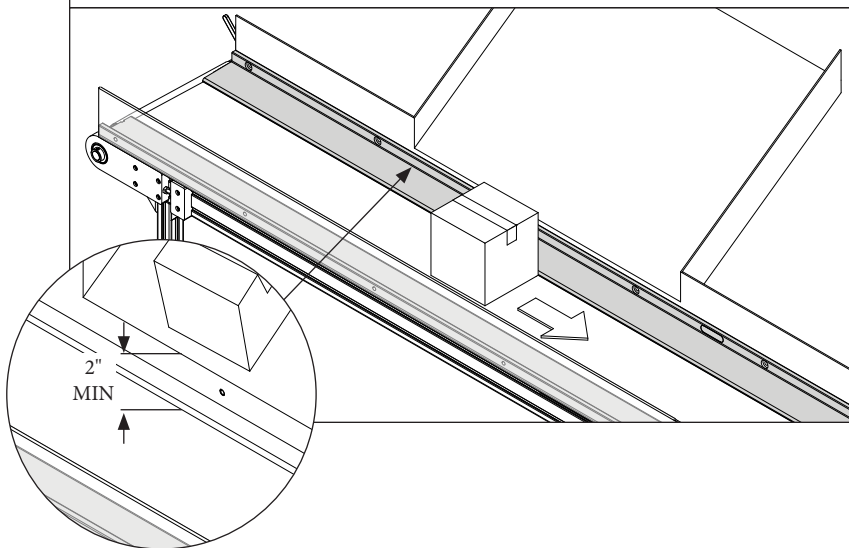

While holding the Edge Protector firmly against the sidewall, use the pre-drilled holes as a template to drill through the wall. Use both the extension bit holder and 1/4" bit while drilling.

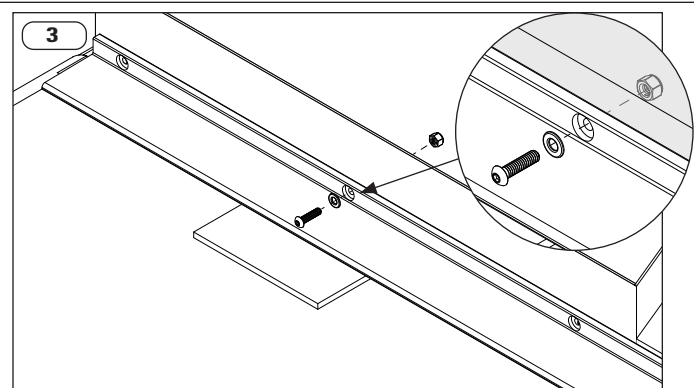

Apply fasten the Belt Edge Protector using the 1/4"-20 bolt, washer, and Nylock nuts provided, following the manufacturer's instructions. Based on the manufacturer's information, a minimum torque of 22 in-lbs is recommended. For best results, tighten each nut to contact with the structure plus one full turn.



## Section 4 - Installation Instructions - BEP (cont.)

4

Once entire segment is bolted to sidewall, insert the provided Link Plate into the bottom slot as shown.

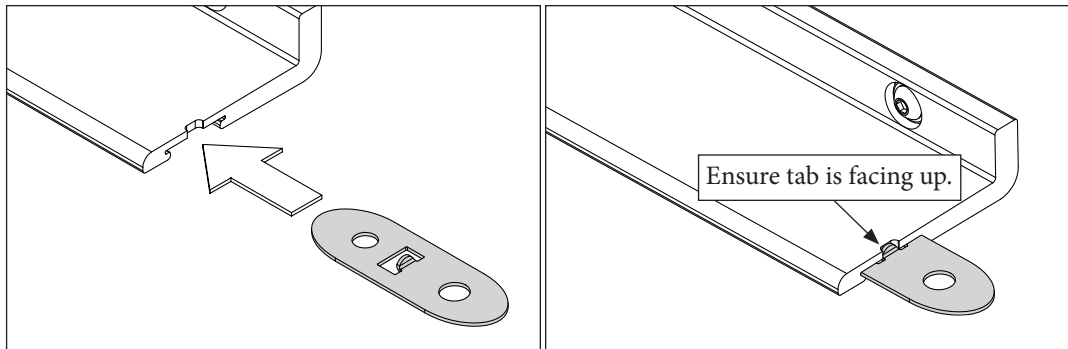

5

With the shims still in place, slide another edge protector onto the Link Plate until the two pieces are pressed together making full contact. Ensure the segments are aligned vertically with each other so no catch point is created. Use additional shims as required to keep the Belt Edge Protector level. Repeat steps 1 through 4 until all required segments are installed.

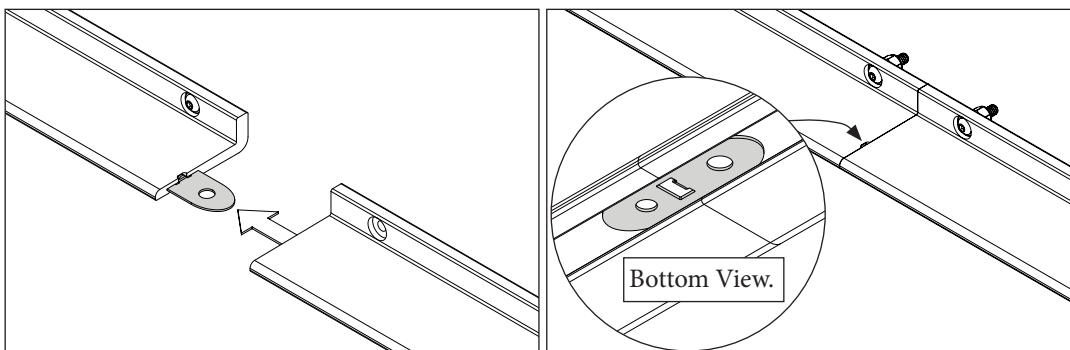

6

If you are unable to utilize one of the pre-drilled holes, use the provided counterbore bit to drill a new hole through the Edge Protector and the sidewall. Drill a counterbore large enough for the provided fasteners. Best practice is to remove the segment to drill the counterbore and to drill through the sidewall with a different bit. Do not drill counterbore completely through the Belt Edge Protector.

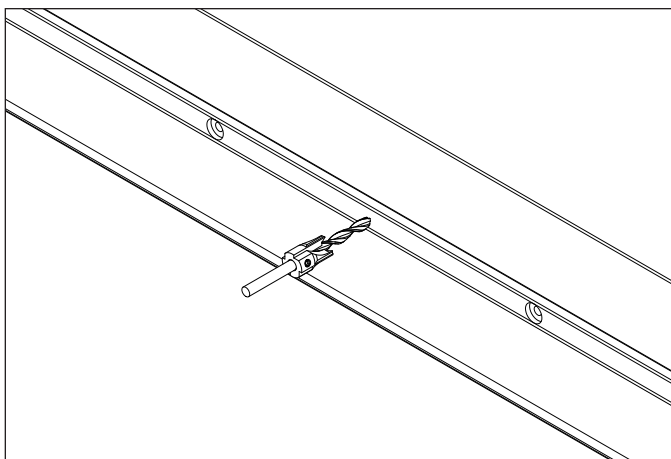

# Section 5 - Pre-Operation Checklist and Testing

---

## 5.1 Pre-Op Checklist

- Recheck that all fasteners are tightened properly.
- Check the segment clearance to the belt.
- Be sure that all installation materials and tools have been removed from the belt and the conveyor area.
- Ensure all segments are flush to each other with no gaps or catch points created.
- Follow proper lock out/tag out processes prior to startup, ensuring the belt is not occupied.

## 5.2 Test Run the Conveyor

- Run the conveyor for at least 15 minutes and inspect the Belt Edge Protector performance.
- If performance is inadequate, add, remove, and/or adjust segment(s) as needed.

**NOTE:** Observing the unit with the belt running and performing properly will help to detect problems or when adjustments are needed.

# Section 6 – Maintenance

---

Flexco Belt Edge Protectors are designed to operate with minimum maintenance. However, to maintain superior performance some service is required. When the units are installed a regular maintenance program should be set up. This program will ensure that the units operate optimally, and problems can be identified and fixed before the units stop working.

All safety procedures for inspection of equipment (stationary or operating) must be observed. The Belt Edge Protectors operate in the immediate vicinity of moving belts. Only visual observations can be made while the belt is running. Service tasks can be done only with the conveyor stopped and the correct lockout/tagout procedures observed.

## 6.1 New Installation Inspection

After the new Belt Edge Protector has run for a few days, a visual inspection must be made to ensure the segments is performing properly.

## 6.2 Routine Visual Inspection (every 2-4 weeks)

A visual inspection of the BEP and belt can determine:

- If a segment is worn out and needs to be replaced.
- If there is damage to the segments.
- If amnesty is stuck on the segments.
- If there is cover damage to the belt.
- If there is direct contact of the segments on the belt.

If any of the above conditions exist, a determination should be made on when the conveyor can be stopped for maintenance.

## Section 6 - Maintenance (cont.)

---

### 6.3 Routine Physical Inspection (every 6-8 weeks)

When the conveyor is not in operation and is properly locked and tagged out, conduct a physical inspection of the BEP to perform the following tasks:

- Clean material buildup off the BEP segments.
- Closely inspect the segments for wear and damage. Replace if needed.
- Ensure no segment-to-belt contact.
- Inspect all fasteners for tightness and wear. Tighten or replace as needed.
- Replace any worn or damaged components.
- When maintenance tasks are completed, test run the conveyor to ensure the BEP is performing properly.

### 6.4 Cleaning Instructions

BEP plastic segments need to be cleaned of any material stuck to or adhered to the segment. If the plastic shows sign of damage or severe erosion, replace the segment.

### 6.5 BEP Wear Inspection

Belt type, belt speed, material being conveyed, installation, and other application factors will affect BEP wear. Visual inspection of missing segments or fasteners is necessary.

### 6.6 Segment Replacement Instructions

#### Replacement of end segments

1. Remove all bolts from the segment requiring replacement.
2. Remove the segment by sliding it away from the adjoining Link Plate.
3. Cut the new segment as required to match the length of the replaced segment. Take care to maintain the position of the holes relative to the ends of the segment.
4. Install the new segment by sliding it onto the adjoining Link Plate. Use shim(s) as necessary to keep the segment level.
5. Use a new ¼-20 bolt and fasten the Belt Edge Protector using the flat washer and nylock nut.

#### Replacement of center segments

1. Remove all bolts from the segment requiring replacement.
2. Remove the segment by gently bending it upward and sliding each end off the adjoining Link Plates.
3. Cut the new segment as required to match the length of the replaced segment. Take care to maintain the position of the holes relative to the ends of the segment.
4. Install the new segment by sliding it onto one adjoining biscuit then gently bending the segment to slide onto the other Link Plate.
5. Use a new ¼-20 bolt and fasten the Belt Edge Protector using the flat washer and nylock nut.

## Section 6 - Maintenance (cont.)

---

### 6.7 BEP Maintenance Log

Conveyor Name/No. \_\_\_\_\_

Date: \_\_\_\_\_ Work done by: \_\_\_\_\_ Service Quote #: \_\_\_\_\_

Activity: \_\_\_\_\_

---

Date: \_\_\_\_\_ – \_\_\_\_\_ Work done by: \_\_\_\_\_ Service Quote #: \_\_\_\_\_

Activity: \_\_\_\_\_

---

Date: \_\_\_\_\_ – \_\_\_\_\_ Work done by: \_\_\_\_\_ Service Quote #: \_\_\_\_\_

Activity: \_\_\_\_\_

---

Date: \_\_\_\_\_ – \_\_\_\_\_ Work done by: \_\_\_\_\_ Service Quote #: \_\_\_\_\_

Activity: \_\_\_\_\_

---

Date: \_\_\_\_\_ – \_\_\_\_\_ Work done by: \_\_\_\_\_ Service Quote #: \_\_\_\_\_

Activity: \_\_\_\_\_

---

Date: \_\_\_\_\_ – \_\_\_\_\_ Work done by: \_\_\_\_\_ Service Quote #: \_\_\_\_\_

Activity: \_\_\_\_\_

---

Date: \_\_\_\_\_ – \_\_\_\_\_ Work done by: \_\_\_\_\_ Service Quote #: \_\_\_\_\_

Activity: \_\_\_\_\_

---

Date: \_\_\_\_\_ – \_\_\_\_\_ Work done by: \_\_\_\_\_ Service Quote #: \_\_\_\_\_

Activity: \_\_\_\_\_

---

# Section 6 - Maintenance (cont.)

## 6.8 BEP Maintenance Checklist

### Conveyor Information:

Conveyor Number: \_\_\_\_\_ Belt Condition: \_\_\_\_\_

Belt Width:  12" (300 mm)  18" (450 mm)  24" (600 mm)  30" (750 mm)  36" (900 mm)  42" (1050 mm)  48" (1200 mm)  54" (1350 mm)  60" (1500 mm)

Head Pulley Diameter (Belt & Lagging): \_\_\_\_\_

Belt Speed: \_\_\_\_\_ fpm Belt Thickness: \_\_\_\_\_ Conveyor Length: \_\_\_\_\_

Belt Splice: \_\_\_\_\_ Condition of Splice: \_\_\_\_\_ Number of splices: \_\_\_\_\_  Skived  Unskived

Material conveyed: \_\_\_\_\_

Days per week run: \_\_\_\_\_ Hours per day run: \_\_\_\_\_

### BEP Overall Performance: (Rate the following 1 - 5, 1 = very poor - 5 = very good)

Appearance:  Comments: \_\_\_\_\_

Location:  Comments: \_\_\_\_\_

Maintenance:  Comments: \_\_\_\_\_

Performance:  Comments: \_\_\_\_\_

Other Comments: \_\_\_\_\_

\_\_\_\_\_  
\_\_\_\_\_  
\_\_\_\_\_  
\_\_\_\_\_  
\_\_\_\_\_  
\_\_\_\_\_



## Section 7 - Troubleshooting

| Problem   | Possible Cause  | Possible Solutions  |
|---|---|---|
| Edge protector horizontal toe is angled upward allowing packages to get underneath          | Non-squared/-vertical sidewalls   | Install shims behind sidewall   |
|   |   | Bend sidewall and secure into correct position  |
| Chutes that merge with the conveyor bed cannot have BEP's installed across the entire width | Poor Chute Design   | Trim BEP at merge point   |
|   |   | Install chute cover that raises the chute at least 1.5" above the conveyor bed  |
| Chutes that do not extend to the sidewall cause a trap point for packages                   | Poor Chute Design   | Raise the chute at least 1.5" above conveyor bed  |
|   |   | Extend chute to sidewall  |
| BEP creates catch point   | BEP installed in middle of conveyor   | BEP is designed to be installed at beginning of conveyor. Install a diverter to gradually move product away from BEP or install from beginning of conveyor. |
| Missing or damaged BEP piece(s)   | Foreign object debris got caught between the surface of the belt and the segment. | Replace with new piece of same length   |
|   | Damage to belt  | Repair belt and replace piece   |
|   | Improper installation   | Replace with new piece of same length   |
|   | Package impact  | Replace with new piece of same length   |
| Ledge created at piece transition   | Missing Link Plate  | Remove piece(s), add Link Plate, and reinstall piece(s)   |
| Mounting screws missing   | Fastener not added or fully tightened during installation                         | Add fastener  |
| Too high or low installation  | No shims used during installation   | Reinstall BEPs using shims between belt and pieces to properly position   |
|   | Too many shims added during installation  | Reinstall BEPs using only one shim height between belt and pieces to properly position  |

## Section 8 - Specifications

---

Conveyor Name/No. \_\_\_\_\_

Date: \_\_\_\_\_

Work done by: \_\_\_\_\_

Service Quote #: \_\_\_\_\_

Conveyor Length: \_\_\_\_\_

No. of BEP Kits \_\_\_\_\_

No. of Install Kits: \_\_\_\_\_

BEP Kit Item Code 108324

Install Kit Item Code 109455

---

## Section 9 – Replacement Parts

---

| DESCRIPTION              | ORDERING NUMBER | ITEM CODE |
|--------------------------|-----------------|-----------|
| HARDWARE REPLACEMENT KIT | BEP-HW          | 109511    |
| REPLACEMENT LINK PLATE   | BEP-LP          | 108331    |



Visit [www.flexco.com](http://www.flexco.com) for other Flexco locations and products, or to find an authorised distributor.

©2023 Flexible Steel Lacing Company. 01-02-24. 108336

