

Segmented Transfer Plates Specialty Bracket Offerings for Non-Standard Installation

Non-standard installation of Segmented Transfer Plates may need an alternative mounting bracket to the standard bracket supplied with your purchase. See the options below and select the best mounting bracket for your application. Contact your local distributor or Flexco Customer Service to order.

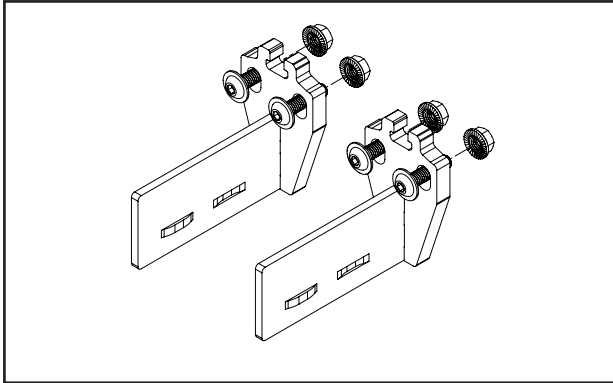

Item Code: 56733

Ordering Number: TG-MTG-BRKT-LOWPRO

- **Compatibility:** Narrow gap STP
- **Installation:** Bolt on
- **Applications:** Airport conveyors installed close to the ground or suspended from the ceiling. Logistics applications where the conveyor is hanging from above and there is no structure below the belt. Installations where aesthetics are required.

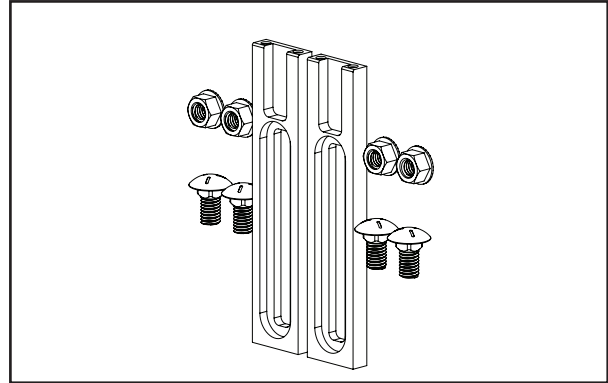

Item Code: 56732

Ordering Number: TG-MTG-BRKT-LONGDROP

- **Compatibility:** Regular STP
- **Installation:** Bolt on or weld
- **Applications:** Articulating boom lines, tail to tail, power curve to horizontal and spiral elevator conveyors where you need to use existing holes and the conveyor structure is between 4" to 7" below the conveyor belt.

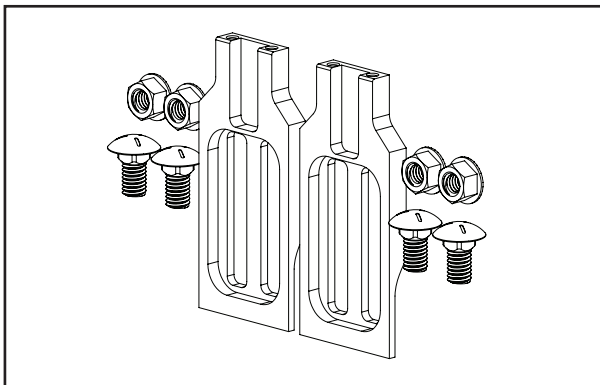

Item Code: 56734

Ordering Number: TG-MTG-BRKT-DUALSLOT

- **Compatibility:** Regular STP
- **Installation:** Bolt on
- **Applications:** For use on DEMATIC conveyors with pop out rollers. Horizontal to roller bed, horizontal to incline, or decline conveyors.

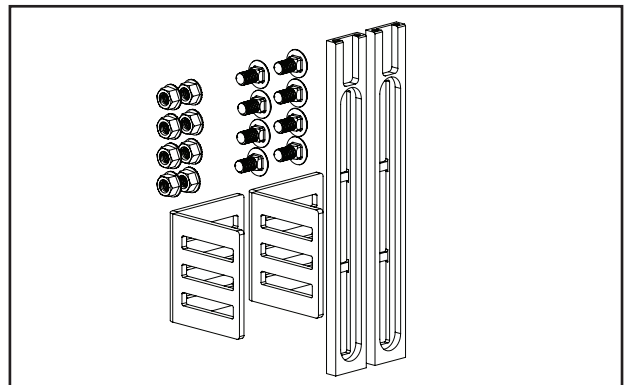

Item Code: 56735

Ordering Number: TG-MTG-KIT-XLNGSSLOT

- **Compatibility:** Regular STP
- **Installation:** Bolt on or weld
- **Applications:** Power curve to power curve, power curve to horizontal conveyors, installations where you must bolt brackets to cross member, or when the conveyor structure is between 2" to 9.5" below the conveyor belt.

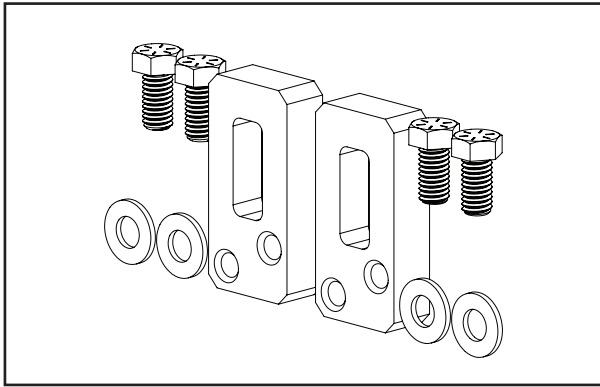

Item Code: 56737

Ordering Number:

TG-MTG-KIT-SOLIDMOUNTREG

- **Compatibility:** Regular STP
- **Installation:** Bolt on
- **Applications:** Blind installations where bracket must be bolted from the outside in, particularly common in USPS facilities with legacy equipment.

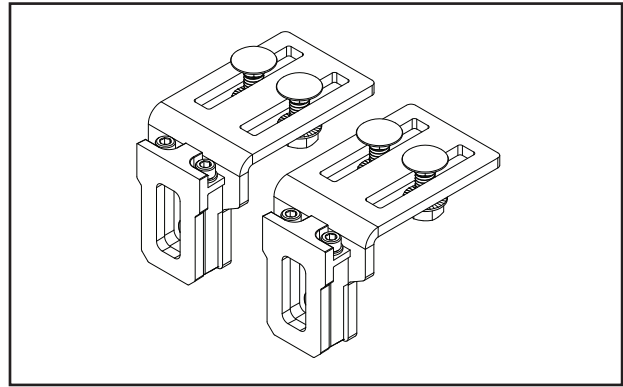

Item Code: 56746

Ordering Number: TG-MTG-BRKT-TOPSLOT

- **Compatibility:** Regular STP
- **Installation:** Bolt on
- **Applications:** For installations where side or bottom access is limited and STP brackets are installed from the top. Common in shrouded conveyors with no sidewall above the belt bed.

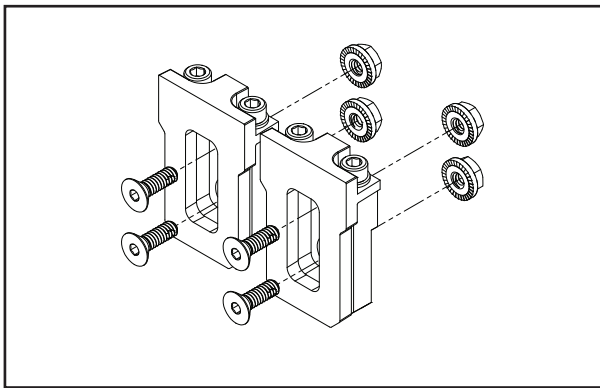

Item Code: 56747

Ordering Number: TG-MTG-BRKT-BACKPLATE

- **Compatibility:** Regular STP
- **Installation:** Bolt on or weld
- **Applications:** Hinge conveyors, horizontal to gravity roller conveyors, and installations where a small footprint bracket is required to clear adjacent components. Similar to regular STP bracket without a lower tab.

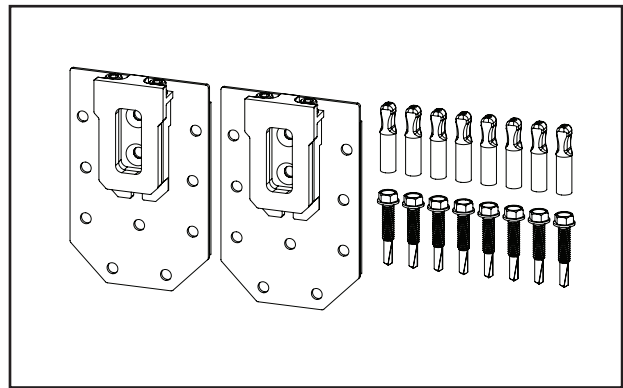

Item Code: 101808

Ordering Number: STP-WIDE-FLANGE-BRACKET

- **Compatibility:** Regular STP
- **Installation:** Bolt on or weld
- **Applications:** Installations where conveyor structure is nonexistent or irregular. Extremely versatile and allows for maximum adjustability. Comes with self tapping screws and bracket can be cut. Requires three screws minimum per plate for secure installation.



2525 Wisconsin Avenue • Downers Grove, IL 60515-4200 • USA
Tel: (630) 971-0150 • Fax: (630) 971-1180 • E-mail: info@flexco.com

Visit www.flexco.com for other Flexco locations and products.

©2022 Flexible Steel Lacing Company. 07-12-22. For Reference: 104854

