

Segmented Transfer Plates Specialty Bracket Offerings for Non-Standard Installation

Non-standard installation of Segmented Transfer Plates may need an alternative mounting bracket to the standard bracket supplied with your purchase. See the options below and select the best mounting bracket for your application. Contact your local distributor or Flexco Customer Service to order.

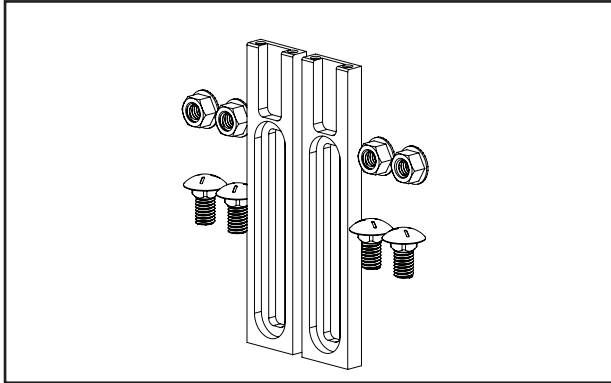

Item Code: 56732

Ordering Number: TG-MTG-BRKT-LONGDROP

- **Compatibility:** Regular STP
- **Installation:** Bolt on or weld
- **Applications:** Articulating boom lines, tail to tail, power curve to horizontal and spiral elevator conveyors where you need to use existing holes and the conveyor structure is between 4"-7" (102-178mm) below the conveyor belt.

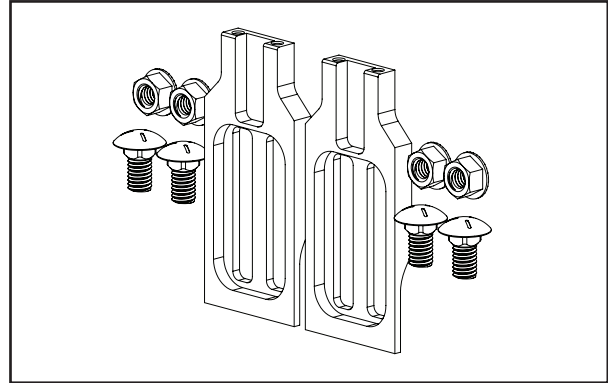

Item Code: 56734

Ordering Number: TG-MTG-BRKT-DUALSLOT

- **Compatibility:** Regular STP
- **Installation:** Bolt on
- **Applications:** For use on DEMATIC conveyors with pop out rollers. Horizontal to roller bed, horizontal to incline, or decline conveyors.

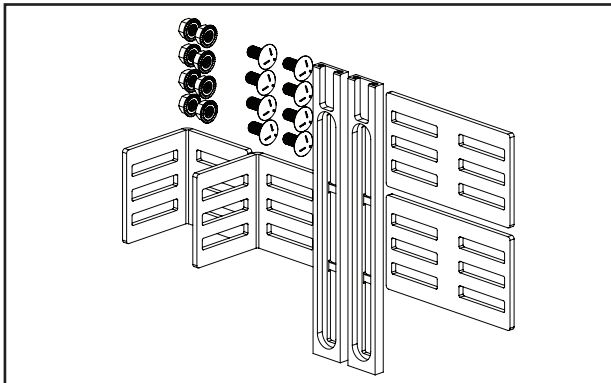

Item Code: 56735

Ordering Number: TG-MTG-KIT-XLNGSSLOT

- **Compatibility:** Regular STP
- **Installation:** Bolt on or weld
- **Applications:** Power curve to power curve, power curve to horizontal conveyors, installations where you must bolt brackets to cross member, or when the conveyor structure is between 2"-9.5" (50-240mm) below the conveyor belt.

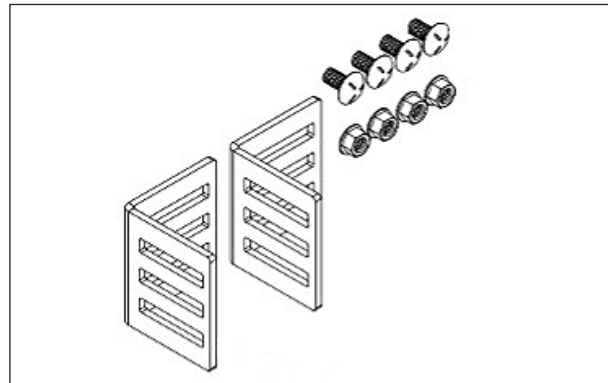

Item Code: 56740

Ordering Number: TGB-MOUNT-L-3SLOTBRKT

- **Compatibility:** Regular or Narrow Gap STP
- **Installation:** Bolt on or weld
- **Applications:** Primarily used with the Extra Long Slot bracket, Single Slot Bracket, and Dual Slot brackets. Can be used to create a side wall for optimal positioning of the standard STP when the mounting conveyor lacks optimal structure.

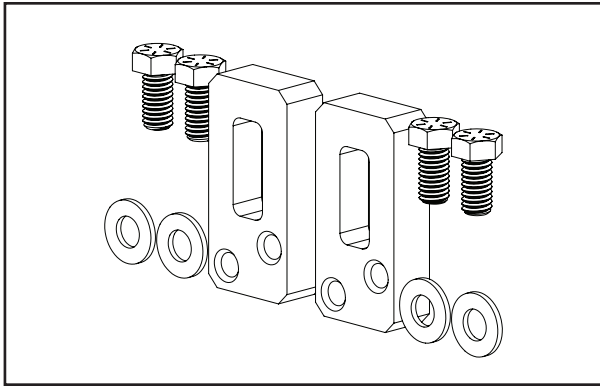

Item Code: 56737

Ordering Number: TG-MTG-KIT-SOLIDMOUNTREG

- **Compatibility:** Regular STP
- **Installation:** Bolt on
- **Applications:** Blind installations where bracket must be bolted from the outside in, particularly common in USPS facilities with legacy equipment.

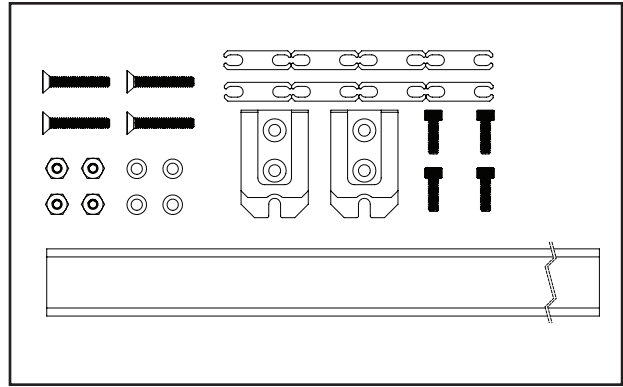

Item Code: 56744

Ordering Number: TG-SBAR-60/1524

- **Compatibility:** Regular STP
- **Installation:** Bolt on
- **Applications:** For standard STP installation 4"-10" (101-254mm). Stainless steel components. Not recommended for direct food contact. Recommended for packaged food.

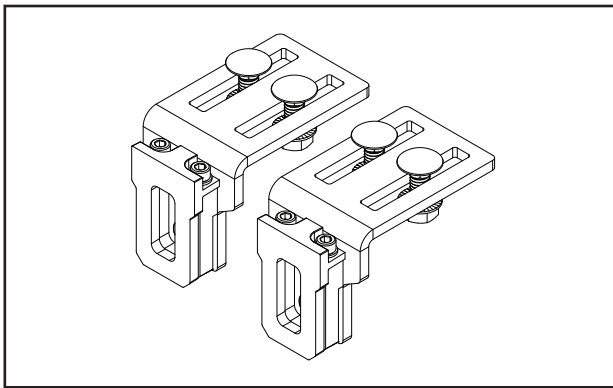

Item Code: 56746

Ordering Number: TG-MTG-BRKT-TOP SLOT

- **Compatibility:** Regular STP
- **Installation:** Bolt on
- **Applications:** For installations where side or bottom access is limited and STP brackets are installed from the top. Common in shrouded conveyors with no sidewall above the belt bed.

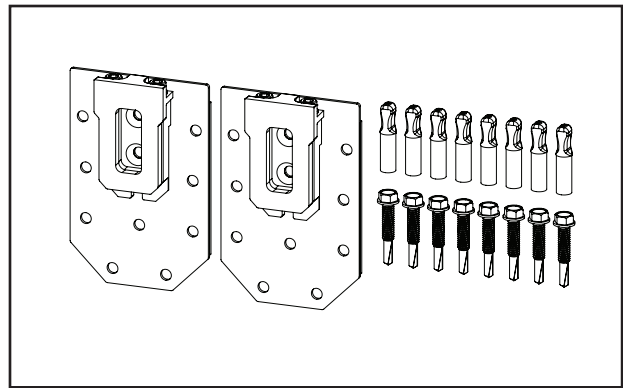

Item Code: 101808

Ordering Number: STP-WIDE-FLANGE-BRACKET

- **Compatibility:** Regular STP
- **Installation:** Bolt on or weld
- **Applications:** Installations where conveyor structure is nonexistent or irregular. Extremely versatile and allows for maximum adjustability. Comes with self tapping screws and bracket can be cut. Requires three screws minimum per plate for secure installation.

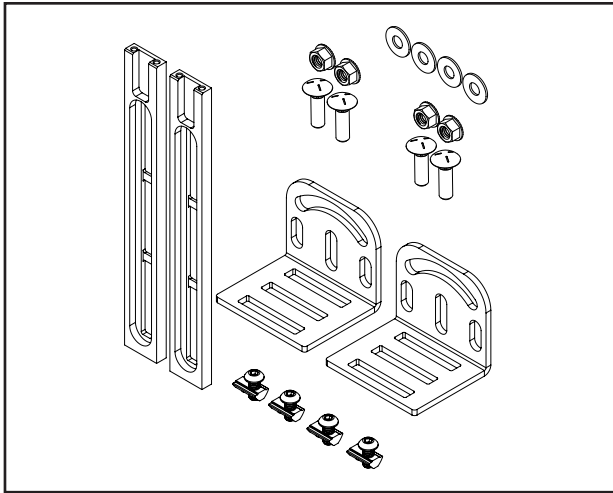

Item Code: 106957

Ordering Number: TG-MTG-KIT-ADJUSTABLE-ARC

- **Compatibility:** Regular STP
- **Installation:** Bolt on or weld
- **Applications:** Waterfall conveyors where there is the need to install the support bar at an angle to properly position the STP segments.

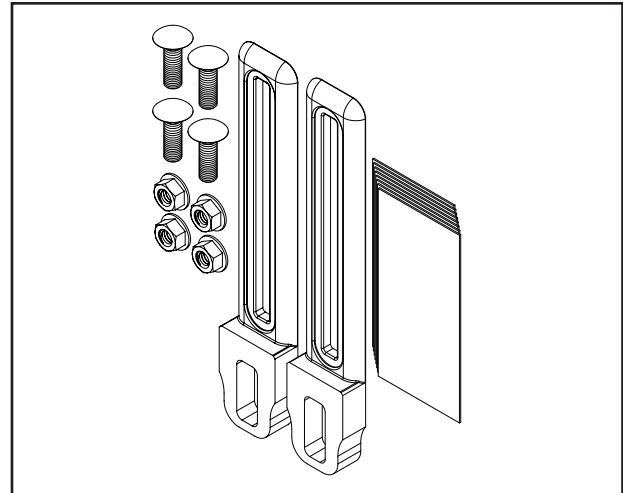

Item Code: 108821

Ordering Number: TG-MTG-KIT-ILD

- **Compatibility:** Regular STP
- **Installation:** Bolt on
- **Applications:** Conveyors where there is insufficient space or access below the conveyors to install the standard STP brackets.