

# Product Guide

EFFECTIVE AUGUST 1, 2024

BCPPGAUS

## Belt Conveyor Products



10 Solent Circuit  
Norwest NSW 2153

Phone: +61 2-8818-2000 Fax: +61 2-8824-6333

Toll Free: 1300 098 435

E-mail: [salesau@flexco.com](mailto:salesau@flexco.com)

[www.flexco.com](http://www.flexco.com)

Patents: [www.flexco.com/patents](http://www.flexco.com/patents)

## INFORMATION

**HEAD OFFICE ADDRESS:** Flexco® (Aust.) Pty Ltd  
10 Solent Circuit  
Baulkham Hills, NSW 2153

**OFFICE TELEPHONE:** +61 2 8818-2000

**WESTERN AUSTRALIA OFFICE ADDRESS:** Unit 1/13 Ernest Clark Rd.  
Canning Vale, WA 6155  
Phone: 08 6253-8081  
Fax: 08 9456-2571

**BUNDABERG OFFICE ADDRESS:** 49 Hanbury Street, Bundaberg, QLD  
4670 Australia  
Ph: 07 4151-0359  
F: 07 4151-0568

**POSTAL ADDRESS:** P.O. Box 6365  
Baulkham Hills B.C. NSW 2153

**EMAIL:** salesau@flexco.com

**OFFICE FACSIMILE:** +61 2 8824-6333

**TERMS AND CONDITIONS:** Prices are in AUD exclusive of GST.

1. Stock items (non-shaded) please refer to asterisk (\*) for specific lead time, if not specified, standard 2-3 days lead-time applies.
2. Some assembled items and larger quantities may take longer, please contact Flexco for specifics.
3. Non-stock items (shaded) please contact Flexco for dispatch options and lead times.
4. Minimum order size for free shipping is \$4,000 net, excluding GST. Free shipping is not applicable to orders delivered to third parties.
5. Strictly Net 30 days unless otherwise negotiated.
6. 3rd party deliveries may be refused—please contact customer service.
7. Flexco endeavours to hold adequate stock levels at all times, however fluctuations do occur; stock is subject to availability.
8. All product refunds are subject to quality approvals before processing and may incur a restocking fee.

**LIMITED LIABILITY:** Every effort is made to ensure the information contained in this price book is accurate and in accordance with all current specifications, however the company cannot be held responsible for any errors and reserves the right, without prior notice, to change specifications, quantities, and prices.

Visit our Website at: [www.flexco.com](http://www.flexco.com)

# Table of Contents

## Belt Cleaners

### Belt Cleaner Information and Selection Guide ..... 5

#### Primary Cleaners

EZP-LS Limited Space Primary Cleaner.....	10
EZP1 Primary Cleaner & ConShear™ Replacement Blades.....	14
EZP1T Twist Tensioner Primary Cleaner.....	19
Spring Covers and Tensioner Lock.....	21
MMP Medium-Duty Primary Cleaner & TuffShear™ Replacement Blades.....	22
MHP Heavy-Duty Primary Cleaner & MegaShear™ Replacement Blades.....	26
MHCP Heavy-Duty Cartridge Primary Cleaner & SuperShear™ Replacement Blades.....	28
H-Type® Primary Cleaners.....	31
Line Connections for Portable Air Tensioner.....	36
H-Type® ESAC Heavy-Duty Primary Cleaner.....	38
H-Type® ESAC with Extra Life -V-Tips Heavy-Duty Primary Cleaner.....	43

#### Secondary Cleaners

Y-Type® Secondary Cleaners.....	48
P-Type® Secondary Cleaners.....	58
R-Type® Reversing Secondary Cleaners.....	60
FMS Medium-Duty Secondary Cleaners.....	62
MHS Heavy-Duty Secondary Cleaners.....	65
H-Type®, P-Type® and R-Type® Lightweight Pole.....	73
Spring Covers and Tensioner Lock.....	74

#### Cartridge Cleaners:

P-Type Secondary Cleaners with Service Advantage Cartridge™.....	75
R-Type Secondary Cleaners with Service Advantage Cartridge.....	82
MHS Heavy-Duty Secondary Cleaners with Service Advantage Cartridge.....	89
Spring Covers and Tensioner Lock.....	102
U-Type® Secondary Cleaners.....	103
MDWS DryWipe Secondary Cleaner.....	109
Continuous Blade Secondary Cleaner.....	113
Motorised Brush Cleaner.....	116
Chevron Belt Cleaner.....	118
Wash Box.....	119

## Belt Cleaner Accessories

Spray Pole Systems.....	120
Live Shaft Hold-Down Rollers.....	122
Belt Cleaner Accessories.....	123
Optional Mounting Kits.....	124

## Safety

Elevate®.....	125
Universal Lightweight Pole.....	128
Inspection Doors.....	129
Mandrel Safety Removal System.....	132
Standard Pulley Lifter.....	133
Flex-Lifter™.....	134

## Impact Beds

#### Flexco Slider and Impact Beds

EZSB-C and EZSB-I Slider Beds; EZIB-L and EZIB-M Impact Beds.....	135
---	-----

#### DRX® Impact Beds

DRX200 - DRX1500 Impact Beds.....	146
DRX3000 Dynamic Bed.....	150
Optional Parts and Tools.....	151

Continued on next page

# Table of Contents

## Belt Conveyor Products

### Ploughs

V-Plough .....	152
Twin Pole V-Plough.....	154
HD® Floating V-Plough .....	156
V-Plough Blade Kits .....	158
Diagonal Plough .....	160
HD Spring-Tensioned Diagonal Plough.....	161
MXDP Diagonal Plough .....	162

### Belt Positioners and Trainers

Belt Positioner™.....	164
PTEZ™.....	166
PT Smart™ Belt Trainer .....	167
PT Max™ Belt Trainer .....	170

### Skirting Systems

Skirt Clamps-RMC1, Flex-Lok™, and FlexSeal™ .....	175
Dual Seal Polyurethane Skirting .....	176
Standard Urethane Skirting .....	177
Enclosed Skirt System .....	178

## Index

by Ordering Number .....	182
by Item Code .....	197



# Belt Cleaner Information and Selection Guide

## Why Are Belt Cleaners Needed?

- **Reduces Maintenance Costs**
  - Minimises manual cleanup.
  - Protects against belt mistracking.
  - Reduces conveyor component replacement costs.
  - Reducing carryback means a reduction in maintenance costs.
- **Improves Safety**
  - Reduces housekeeping problems.
  - A majority of conveyor-related accidents happen while maintenance tasks are being done.
- **Keeps Conveyors Running Efficiently and Consistently**
  - Reduces unscheduled downtime.
  - Increases production uptime.
- **Saves Money**
  - Increases belt wear life.
  - Extends life of rollers, pulleys and splices.
  - High cost of accidents.



## Types of Belt Cleaners

- **Primary Cleaners**
  - Mounted on the head pulley.
  - Mounted below the material flow.
  - Removes the big stuff. Typically cleans off up to 80% of the initial carryback.
- **Secondary Cleaners**
  - Located just past where the belt leaves the head pulley and anywhere down the beltline.
  - Special secondaries may allow for mounting under the head pulley.
  - Removes sticky fines – the final cleaning job.
  - May require a hold-down roller for maximum performance.
- **Specialty Cleaners**
  - Primary Cleaners or Secondaries designed especially for specific or extreme applications.

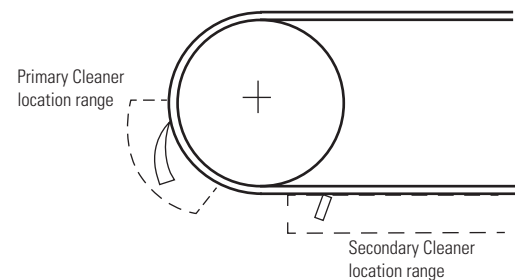

## Definition of Terms

- **Carryback**—Material that sticks to the belt after it leaves the transfer point and continues falling off along the conveyor's return side.
- **Material Path**—The section of the belt where most of the material is conveyed. Typically the center 2/3 of the belt.
- **Hold-Down Roller**—A stabilising roller or pressure roller located on top of the return side of the belt to prevent belt flap or to provide a consistent flat surface for the blades on a lighter-tensioned belt.

# Types of Cleaner Blades

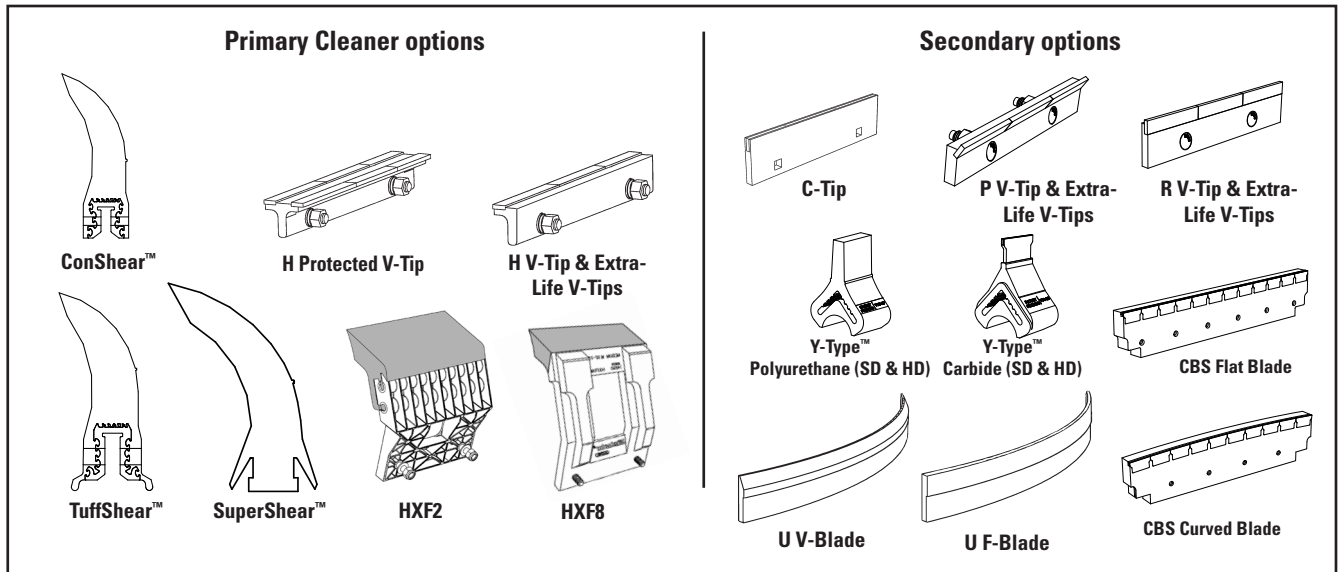

**F-Tip/Blade** - for mechanically fastened belts    **V-Tip/Blade** - for vulcanised belts only - **C-Tip/Blade** - for both

## Polyurethane Blades

Not all polyurethanes are the same. Flexco's polyurethane blades are specially formulated for abrasion resistance and long wear. Independent testing has shown that Flexco's polyurethane blades last as much as 30% longer than other OEM blades.

- Easy on the belt.
- Work well with mechanical splices.
- Economical.
- Specialty formulations for high heat, chemical resistance, or water removal.
- FRAS for underground applications.

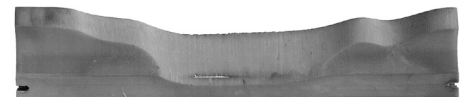

Less advanced polyurethane formulations result in blades that experience quicker wear and provide less-efficient cleaning.

## Tungsten Carbide

Excellent for superior cleaning efficiency and long wear. The quality and application of carbides can vary. Flexco has invested years of research and testing to develop tungsten carbide tips for both vulcanised and mechanically fastened belts; and a quality process ensures consistent results.

- Superior cleaning.
- Long wear.
- C-Tips/blades for mechanical splices and V-Tips/blades for vulcanised belts.

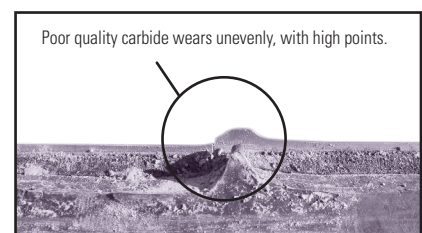

Poor quality carbide wears unevenly, with high points.

## Blade Angle (Secondary cleaners)

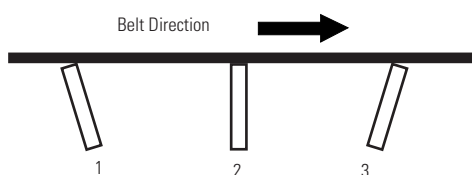

1. Aggressive - excellent cleanability, high risk for belt damage.
2. 90° to belt - good cleaning efficiency; must have good blade relief for splices (Flexco recommended).
3. Wiping - a little less cleaning power; safer on belts in poor condition or with poor mechanical splices.

# Belt Cleaning Systems

## ***Keys to Good Belt Cleaning***

- Proper cleaner selection for the application
- Correct installation
- Regular service maintenance

## ***Specifying and Ordering Belt Cleaners***

### ***Information needed:***

- A.** Belt Width
- B.** Conveyor frame (structure) width
- C.** Head pulley diameter
- D.** For Primary Cleaners - what is the belt's material path?
- E.** Material conveyed (dry, wet, sticky, etc.)
- F.** Type of belt splice:
  - Mechanical - skived or unskived
  - Vulcanised
- G.** Temperature or other extreme environmental factors
- H.** Does the belt reverse?

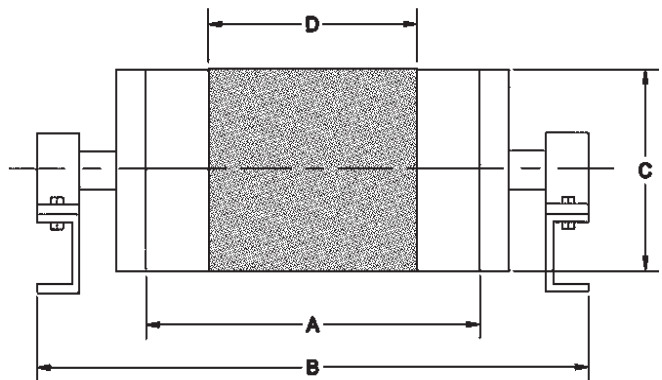

# Primary Cleaner Selection Guide







## Primary Cleaner Specification Chart

APPLICATION DESCRIPTION	EZP-LS	EZP1, HIGH TEMP EZP1	MMP	MHCP	H-TYPE® (HFX2, XF, XF8)	H-TYPE® (V)
Belt Width*	300–1500mm	450–1800mm	600–2100mm	600–2100mm	450–2400mm	450–3000mm
Head Pulley Diameter	150–550mm	250–900mm	400–1200mm	500–1200mm	250–1325mm	250–1575mm
Reversing Belts	Yes	Yes	Yes	Yes	Yes	Yes
Mechanical Fasteners	Yes	Yes	Yes	Yes	Yes	No



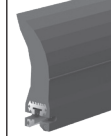
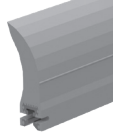

\*Special sizes available upon request.

Contact Flexco for pulleys over 1700 mm diameter.

## Primary Cleaner Blade Specifications

								
<b>Blade Type</b>	ConShear™ LS	ConShear™ LS High Temp	ConShear™ LS White (Chemical Resistant/Food Grade) ‡	ConShear™	ConShear™ High Temp	ConShear™ White (Chemical Resistant/Food Grade) ‡	ConShear™ Ultra High Temp	TuffShear™
<b>Temperature Range</b>	-35 to 82°C	up to 135°C with spikes to 163°C	-35 to 82°C	-35 to 82°C	up to 135°C with spikes to 163°C	-35 to 82°C	up to 200°C with spikes to 232°C	-35 to 82°C
<b>Polyurethane</b>	Yes	Yes	Yes	Yes	Yes	Yes	Yes	Yes
<b>Durometer</b>	83	93	83	83	93	83	90	83
<b>Tungsten Carbide</b>	No	No	No	No	No	No	No	No
<b>Work with Mechanical Fasteners</b>	Yes	Yes	Yes	Yes	Yes	Yes	Yes	Yes
<b>FRAS</b>	Contact Flexco							

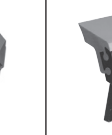
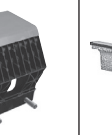
## Primary Cleaner Blade Specifications (cont.)

						
<b>BLADE TYPE</b>	SuperShear™	HXF	HXF2	H V-Tip	H Protected V-Tip	Extra Life V-Tips*
<b>Temperature Range</b>	-35 to 82°C	-35 to 82°C	-35 to 82°C	-35 to 205°C	-35 to 205°C	-35 to 205°C
<b>Polyurethane</b>	Yes	Yes	Yes	No	No	No
<b>Durometer</b>	90	84	83	N/A	N/A	N/A
<b>Tungsten Carbide</b>	No	No	No	Yes	Yes	Yes
<b>Work with Mechanical Fasteners</b>	Yes	Yes	Yes	No	No	No
<b>FRAS</b>	Yes	Yes	No	N/A	N/A	N/A

\*Extra Life Tips available in tip lengths of 15, 20 and 25mm

**For Belt Speed information please consult your Flexco representative**

# Secondary Cleaner Selection Guide

## Secondary Cleaner Specification Chart

APPLICATION DESCRIPTION	<a href="#">MHS (C-Tip)</a>	<a href="#">MHS (V-Tip)</a>	<a href="#">P-TYPE® (C-Tip)</a>	<a href="#">P-TYPE (V-Tip)</a>	<a href="#">P-TYPE-LS (C-Tip)</a>	<a href="#">Y-Type™ SD Polyurethane</a>	<a href="#">Y-Type SD Carbide</a>	<a href="#">Y-Type HD Polyurethane</a>	<a href="#">Y-Type HD Carbide</a>
Belt Width*	600–2400mm	600–2400mm	450–2400mm	450–2400mm	450–2400mm	450–1200mm	450–1200mm	900–1800mm	900–1800mm
Secondary Cleaner Blade Options	Yes	Yes	No	No	No	Yes	Yes	Yes	Yes
Work with Mechanical Fasteners	Yes	No	Yes	No	Yes	Yes	Yes	Yes	Yes

\*Special sizes available upon request.  
Contact Flexco for belt widths over 3000mm.

## Secondary Cleaner Specification Chart (cont.)

APPLICATION DESCRIPTION	<a href="#">FMS (V-Tip)</a>	<a href="#">U-TYPE® (F-Blade)</a>	<a href="#">U-TYPE (V-Blade)</a>	<a href="#">R-TYPE® (C-Tip)</a>	<a href="#">R-TYPE (V-Tip)</a>	<a href="#">Chevron</a>	<a href="#">Brush Cleaner</a>	<a href="#">MDWS (DryWipe)</a>	<a href="#">CBS</a>
Belt Width*	600–2400mm	450–3000mm	450–2500mm	450–2400mm	450–2400mm	450–1500mm	450–2100mm	450–1800mm	450–2400mm
Secondary Cleaner Blade Options	Yes	No	No	Yes	Yes	Yes	Yes	Yes	Yes
Work with Mechanical Fasteners	No	Yes	No	Yes	No	Yes	Yes	Yes	Yes

\*Special sizes available upon request.  
Contact Flexco for belt widths over 3000mm.

## Secondary Cleaner Blade Specifications

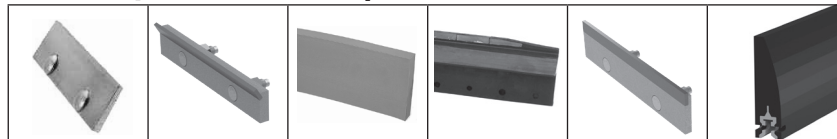

BLADE TYPE	<a href="#">C-Tip</a>	<a href="#">P V-Tip*</a>	<a href="#">U F-Blade</a>	<a href="#">U V-Blade</a>	<a href="#">R V-Tip*</a>	<a href="#">DryWipe Blade</a>
Temperature Range	-35 to 205°C	-35 to 205°C	-35 to 82°C	-35 to 82°C	-35 to 205°C	-35 to 82°C
Polyurethane	No	No	Yes	Rubber	No	Yes
Durometer	N/A	N/A	90	83	N/A	59
Tungsten Carbide	Yes	Yes	No	Yes	Yes	No
Work with Mechanical Fasteners	Yes	No	Yes	No	No	Yes

\*Available in 10, 15, 20 and 25mm tip lengths

## Secondary Cleaner Blade Specifications cont.

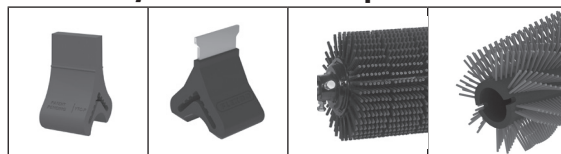

BLADE TYPE	<a href="#">Y-Type Polyurethane</a>	<a href="#">Y-Type Carbide</a>	<a href="#">Chevron</a>	<a href="#">Brush Cleaner</a>
Temperature Range	-35 to 82°C	-35 to 82°C	-35 to 82°C	-30 to 82°C
Polyurethane	Yes	No	Rubber	Polypropylene
Durometer	86A	N/A	N/A	N/A
Tungsten Carbide	No	Yes	No	No
Work with Mechanical Fasteners	Yes	Yes	Yes	Yes

**For Belt Speed information please consult your Flexco representative**



# Product Ordering Information

## EZP-LS Standard and Stainless Steel Limited Space Primary Cleaner



### Standard EZP-LS Belt Width Minus 50 mm

BELT WIDTH	BLADE COVERAGE	ORDERING NUMBER	ITEM CODE	WT. KG
mm	mm			
300	250	EZP-LS212	77127	11.3
450	400	EZP-LS218	77128	12.8
600	550	EZP-LS224	77129	14.4
750	700	EZP-LS230	77130	16.0
900	850	EZP-LS236	77131	17.6
1050	1000	EZP-LS242	77132	19.1
1200	1150	EZP-LS248	77133	20.7
1350	1300	EZP-LS254	77134	22.2
1500	1450	EZP-LS260	77135	23.9

### EZP-LS Stainless Steel Belt Width Minus 50 mm

BELT WIDTH	BLADE COVERAGE	ORDERING NUMBER	ITEM CODE	WT. KG
mm	mm			
300	250	EZP-LS212-S/S	62836	11.3
450	400	EZP-LS218-S/S	62837	12.8
600	550	EZP-LS224-S/S	62838	14.4
750	700	EZP-LS230-S/S	62839	16.0
900	850	EZP-LS236-S/S	62840	17.6
1050	1000	EZP-LS242-S/S	62841	19.1
1200	1150	EZP-LS248-S/S	62842	20.7
1350	1300	EZP-LS254-S/S	62843	22.2
1500	1450	EZP-LS260-S/S	62844	23.9

\*Lead time: 4 weeks

### EZP-LS High-Temp Belt Width Minus 50 mm

BELT WIDTH	BLADE COVERAGE	ORDERING NUMBER	ITEM CODE	WT. KG
mm	mm			
300	250	EZP-LS212HT	77746	24.8
450	400	EZP-LS218HT	77747	28.2
600	550	EZP-LS224HT	77748	31.7
750	700	EZP-LS230HT	77749	35.1
900	850	EZP-LS236HT	77750	38.6
1050	1000	EZP-LS242HT	77751	42.0
1200	1150	EZP-LS248HT	77752	45.5
1350	1300	EZP-LS254HT	77753	48.9
1500	1450	EZP-LS260HT	77754	52.5

### EZP-LS Stainless Steel High-Temp Belt Width Minus 50 mm

BELT WIDTH	BLADE COVERAGE	ORDERING NUMBER	ITEM CODE	WT. KG
mm	mm			
300	250	EZP-LS212HT-S/S	62845	11.3
450	400	EZP-LS218HT-S/S	62846	12.8
600	550	EZP-LS224HT-S/S	62847	14.4
750	700	EZP-LS230HT-S/S	62848	16.0
900	850	EZP-LS236HT-S/S	62849	17.6
1050	1000	EZP-LS242HT-S/S	62850	19.1
1200	1150	EZP-LS248HT-S/S	62851	20.7
1350	1300	EZP-LS254HT-S/S	62852	22.2
1500	1450	EZP-LS260HT-S/S	62853	23.9

\*Lead time: 4 weeks

### EZP-LS Stainless Steel - White ConShear™ LS Blade Belt Width Minus 50 mm

BELT WIDTH	BLADE COVERAGE	ORDERING NUMBER	ITEM CODE	WT. KG
mm	mm			
300	250	CLSFG-212	77144	11.3
450	400	CLSFG-218	77145	12.8
600	550	CLSFG-224	77146	14.4
750	700	CLSFG-230	77147	16
900	850	CLSFG-236	77148	17.5
1050	1000	CLSFG-242	77149	19.1
1200	1150	CLSFG-248	77150	20.7
1350	1300	CLSFG-254	77151	22.2
1500	1450	CLSFG-260	77152	23.9

  Stock items (non-shaded) refer to (\*) for specific lead time, if not specified, standard lead time applies.

  Non-stock items (shaded) please contact Flexco for dispatch options and lead times.

# Specifications & Guidelines

## EZP-LS Limited Space Primary Cleaner

### Pole Length Specifications\*

CLEANER SIZE	POLE LENGTH	MAXIMUM CONVEYOR SPAN
mm	mm	mm
300	1050	925
450	1200	1075
600	1350	1225
750	1500	1375
900	1650	1525
1050	1800	1675
1200	1950	1825
1350	2200	2075
1500	2350	2225
1800	2650	2525

Pole Diameter - 48 mm

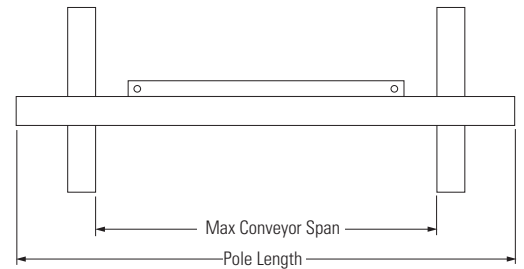

### Clearance Guidelines for Installation

HORIZONTAL CLEARANCE REQUIRED	VERTICAL CLEARANCE REQUIRED
mm	mm
75	165

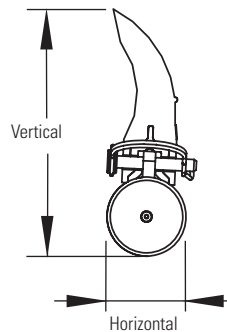

### Pole Location Specs

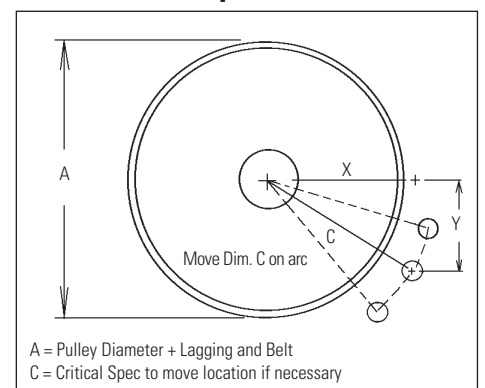

### LST Spring Length Chart

BLADE WIDTH	PURPLE SPRINGS	SILVER SPRINGS	BLACK SPRINGS
mm	mm	mm	mm
254	51	N/A	N/A
406	41	54	N/A
559	N/A	51	N/A
711	N/A	48	N/A
864	N/A	44	N/A
1016	N/A	38	N/A
1168	N/A	35	51
1321	N/A	N/A	51
1473	N/A	N/A	48

Shading indicates preferred spring option

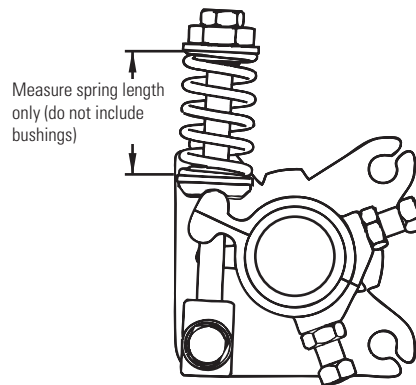

### Pole Location Chart

A	X	Y	C
mm	mm	mm	mm
152	67	140	156
178	83	140	162
203	99	140	171
229	111	140	178
254	127	140	187
279	140	140	197
305	156	140	210
330	168	140	219
356	181	140	229
381	194	140	238
406	210	140	251
432	222	140	264
457	235	140	273
483	248	140	286
508	260	140	295
533	273	140	308
559	286	140	318

### Specifications:

- Maximum Belt Speed..... Contact Flexco
- Temperature Rating..... -35 to 82°C
- Minimum Pulley Diameter..... 150 mm
- Blade Height..... 115 mm
- Usable Blade Wear Length..... 60 mm
- Blade..... Polyurethane (proprietary blend for abrasion resistance and long wear)
- Available for Belt Widths ..... 300 to 1800 mm

# Replacement Parts List

## EZP-LS Limited Space Primary Cleaner

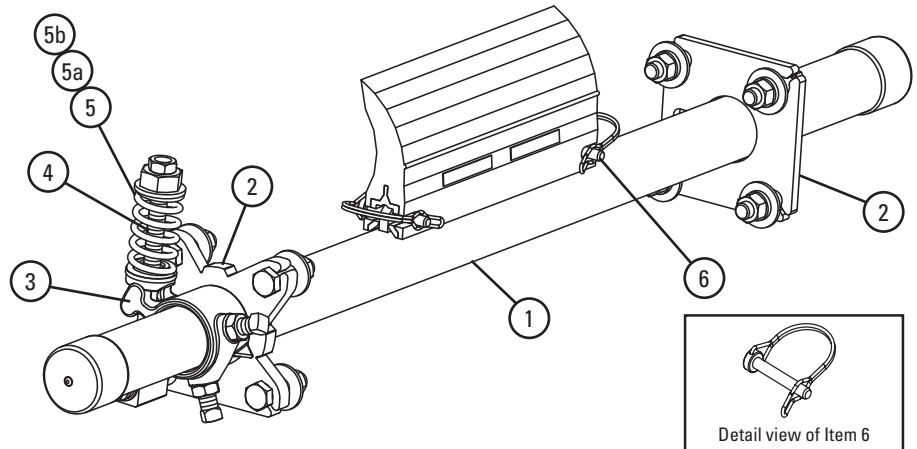

### Replacement Parts

REF	DESCRIPTION	MILD STEEL			STAINLESS STEEL		
		ORDERING NUMBER	ITEM CODE	WT. KG	ORDERING NUMBER	ITEM CODE	WT. KG
1	300mm Pole	LSP12	77070	6.0	LSP12-S/S	77079	6.0
	450mm Pole	LSP18	77071	7.0	LSP18-S/S	77080	7.0
	600mm Pole	LSP24	77072	8.0	LSP24-S/S	77081	8.0
	750mm Pole	LSP30	77073	9.0	LSP30-S/S	77082	9.0
	900mm Pole	LSP36	77074	10.0	LSP36-S/S	77083	10.0
	1050mm Pole	LSP42	77075	11.0	LSP42-S/S	77084	11.0
	1200mm Pole	LSP48	77076	12.0	LSP48-S/S	77085	12.0
	1350mm Pole	LSP54	77077	13.0	LSP54-S/S	77086	13.0
	1500mm Pole	LSP60	77078	14.1	LSP60-S/S	77087	14.1
2	Mounting Plate Kit* (incl. (1) ea. tensioner mounting plate & pole mounting plate)	LSTMPK	77366	1.6	LSTMPK-S/S	78933	1.6
2a	SS Mounting Plate Kit (52"/1300mm+)* (incl. (2) tensioner mounting plate)				LSTMPK2-S/S	78462	3.3
3	Torque Arm Kit* (1 ea.)	LST-TAK	77120	0.6	LST-TAK	77120	0.6
4	Pivot Block/Rod Kit* (1 ea.)	LSTPB-RK	77367	0.4	LSTPB-RK	77367	0.4
5	Tension Spring - Purple (1 ea.)	LS-SP	77365	0.1	CTS-B-S/S	78387	0.1
5a	Tension Spring - White (1 ea.)	LS-SW	77117	0.1	LS-SW-S/S	78850	0.15
5b	Tension Spring - Silver (1 ea.)	LS-SS	77118	0.1			
6	LS Blade Pin (1 ea.)	LS-BP	77114	0.05	LS-BP-S/S	77115	0.05
-	LST Spring Tensioner* - Purple (incl. (1) tensioner mounting plate & (1) ea. items 3, 4 & 5)	LST-P	77121	3.4	LST-B-S/S	77124	3.4
-	LST Spring Tensioner* - White (incl. (1) tensioner mounting plate & (1) ea. items 3, 4 & 5a)	LST-W	77122	3.5	LST-W-S/S	77125	3.5
-	LST Spring Tensioner* - Silver (incl. (1) tensioner mounting plate & (1) ea. items 3, 4 & 5b) (77126 - stainless steel incl. (2) ea.)	LST-S	77123	3.5	LST-W-S/S-2	77126	6.9

\*Hardware Included

For best results use Flexco Genuine Replacement Blades and Parts.

 Stock items (non-shaded) refer to (\*) for specific lead time, if not specified, standard lead time applies.

 Non-stock items (shaded) please contact Flexco for dispatch options and lead times.

### Spring Tensioner Selection Chart - Mild Steel

CLEANER BLADE WIDTH	77121 LST-P	77122 LST-W	77123 LST-S
ConShear-LS 250-400mm	X		
ConShear-LS 550-1150mm		X	
ConShear-LS 1300-1450mm			X

### Spring Tensioner Selection Chart - Stainless Steel

CLEANER BLADE WIDTH	77124 LST-B-S/S	77125 LST-W-S/S	77126 LST-W-S/S-2
ConShear-LS 250-700mm	X		
ConShear-LS 850-1150mm		X	
ConShear-LS 1300-1750mm			X

# Replacement ConShear™ Blades

**EZP-LS**  
Standard and Stainless Steel  
Limited Space Primary Cleaner

## Standard LS ConShear™ Blades

BELT WIDTH	BLADE WIDTH	ORDERING NUMBER	ITEM CODE	WT. KG
mm	mm			
300	250	CRB-LS10	77088	1.0
450	400	CRB-LS16	77089	1.5
600	550	CRB-LS22	77090	2.1
750	700	CRB-LS28	77091	2.6
900	850	CRB-LS34	77092	3.2
1050	1000	CRB-LS40	77093	3.8
1200	1150	CRB-LS46	77094	4.4
1350	1300	CRB-LS52	77095	4.9
1500	1450	CRB-LS58	77096	5.5

Other blade sizes available upon request.



## High-Temp LS ConShear™ Blades

BELT WIDTH	BLADE WIDTH	ORDERING NUMBER	ITEM CODE	WT. LBS.
mm	mm			
450	400	CRB-LS16HT	77552	1.5
600	550	CRB-LS22HT	77553	2.1
750	700	CRB-LS28HT	77554	2.6
900	850	CRB-LS34HT	77555	3.2
1050	1000	CRB-LS40HT	77556	3.8
1200	1150	CRB-LS46HT	77557	4.4
1350	1300	CRB-LS52HT	77558	4.9
1500	1450	CRB-LS58HT	77559	5.5

Other blade sizes available upon request.

## Chemical Resistant/Food Grade LS ConShear™ White Blades ‡

BELT WIDTH	BLADE WIDTH	ORDERING NUMBER	ITEM CODE	WT. KG
mm	mm			
300	250	CRB-LS10W	77097	1.0
450	400	CRB-LS16W	77098	1.5
600	550	CRB-LS22W	77099	2.1
750	700	CRB-LS28W	77100	2.6
900	850	CRB-LS34W	77101	3.2
1050	1000	CRB-LS40W	77102	3.8
1200	1150	CRB-LS46W	77103	4.4
1350	1300	CRB-LS52W	77104	4.9
1500	1450	CRB-LS58W	77105	5.5

‡ If ingredients used in the polyurethane formulation of this blade comply with the relevant requirements of 21 CFR (FDA Code of Federal Regulations) for use in repeated bulk dry food applications.

Stock items (non-shaded) refer to (\*) for specific lead time, if not specified, standard lead time applies.  
 Non-stock items (shaded) please contact Flexco for dispatch options and lead times.

# Product Ordering Information

## EZP1 Standard Duty Primary Cleaner and EZP1 Stainless Steel Primary Cleaner



### Standard EZP1 Belt Width Minus 50 mm

BELT WIDTH	BLADE COVERAGE	ORDERING NUMBER	ITEM CODE	WT. KG
mm	mm			
450	400	EZP1-218	75611	25.1
600	550	EZP1-224	75612	27.8
750	700	EZP1-230	75613	30.5
900	850	EZP1-236	75614	33.2
1050	1000	EZP1-242	75615	35.9
1200	1150	EZP1-248	75616	38.6
1350	1300	EZP1-254	75617	41.2
1500	1450	EZP1-260	75618	43.9
1800	1750	EZP1-272	75771	46.6

### EZP1 Stainless Steel Belt Width Minus 50 mm

BELT WIDTH	BLADE COVERAGE	ORDERING NUMBER	ITEM CODE	WT. KG
mm	mm			
450	400	EZP1-218-S/S	61081	25.7
600	550	EZP1-224-S/S	61082	28.4
750	700	EZP1-230-S/S	61017	31.1
900	850	EZP1-236-S/S	61083	33.9
1050	1000	EZP1-242-S/S	61016	36.6
1200	1150	EZP1-248-S/S	61084	39.3
1350	1300	EZP1-254-S/S	61085	42
1500	1450	EZP1-260-S/S	61086	44.8
1800	1750	EZP1-272-S/S	61087	47.5

Other blade sizes available upon request.

### EZP1 High-Temp Belt Width Minus 50 mm

BELT WIDTH	BLADE COVERAGE	ORDERING NUMBER	ITEM CODE	WT. KG
mm	mm			
300	250	HTF212	76658	22.5
450	400	HTF218	76659	25.1
600	550	HTF224	76660	27.8
750	700	HTF230	76661	30.5
900	850	HTF236	76662	33.2
1050	1000	HTF242	76663	35.9
1200	1150	HTF248	76664	38.6
1350	1300	HTF254	76665	41.2
1500	1450	HTF260	76666	43.9
1800	1750	HTF272	76667	46.6

### EZP1 Stainless Steel High-Temp Belt Width Minus 50 mm

BELT WIDTH	BLADE COVERAGE	ORDERING NUMBER	ITEM CODE	WT. KG
mm	mm			
300	250	HTF212-S/S	62826	22.0
450	400	HTF218-S/S	62827	25.1
600	550	HTF224-S/S	62828	27.8
750	700	HTF230-S/S	62829	30.5
900	850	HTF236-S/S	62830	33.2
1050	1000	HTF242-S/S	62831	35.9
1200	1150	HTF248-S/S	62832	38.6
1350	1300	HTF254-S/S	62833	41.2
1500	1450	HTF260-S/S	62834	43.9
1800	1750	HTF272-S/S	62835	46.6

### EZP1 Stainless Steel - White ConShear™ Blade Belt Width Minus 50 mm

BELT WIDTH	BLADE COVERAGE	ORDERING NUMBER	ITEM CODE	WT. KG
mm	mm			
300	250	CFG-212	78838	22.5
450	400	CFG-218	78839	25.1
600	550	CFG-224	78840	27.8
750	700	CFG-230	78841	30.5
900	850	CFG-236	78842	33.2
1050	1000	CFG-242	78843	35.9
1200	1150	CFG-248	78844	38.5
1350	1300	CFG-254	78845	41.2
1500	1450	CFG-260	78846	43.9
1800	1750	CFG-272	78847	46.6

### EZP1 Stainless Steel Ultra High-Temp Belt Width Minus 50 mm

BELT WIDTH	BLADE COVERAGE	ORDERING NUMBER	ITEM CODE	WT. KG
mm	mm			
450	400	EZP1-UHT2-450-S/S	66956	25.1
600	550	EZP1-UHT2-600-S/S	66957	27.8
750	700	EZP1-UHT2-750-S/S	66958	30.4
900	850	EZP1-UHT2-900-S/S	66959	33.1
1050	1000	EZP1-UHT2-1050-S/S	66960	35.8
1200	1150	EZP1-UHT2-1200-S/S	66961	38.5
1350	1300	EZP1-UHT2-1350-S/S	66962	41.1
1500	1450	EZP1-UHT2-1500-S/S	66963	43.8
1800	1750	EZP1-UHT2-1800-S/S	66964	46.5



# Specifications & Guidelines

## EZP1 Standard Duty Primary Cleaner

### Pole Length Specifications\*

CLEANER SIZE	POLE LENGTH	MAXIMUM CONVEYOR SPAN
mm	mm	mm
300	1050	925
450	1200	1075
600	1350	1225
750	1500	1375
900	1650	1525
1050	1800	1675
1200	1950	1825
1350	2200	2075
1500	2350	2225
1800	2650	2525

Pole Diameter - 60 mm

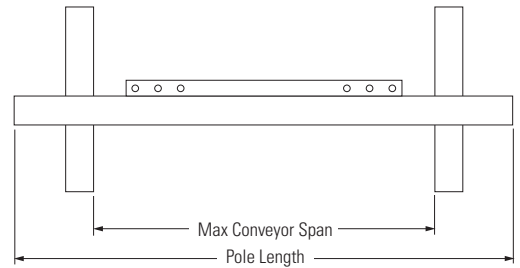

### Clearance Guidelines for Installation

HORIZONTAL CLEARANCE REQUIRED	VERTICAL CLEARANCE REQUIRED
mm	mm
100	238

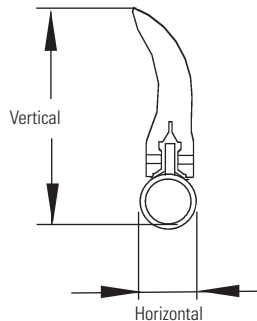

### Pole Location Specs

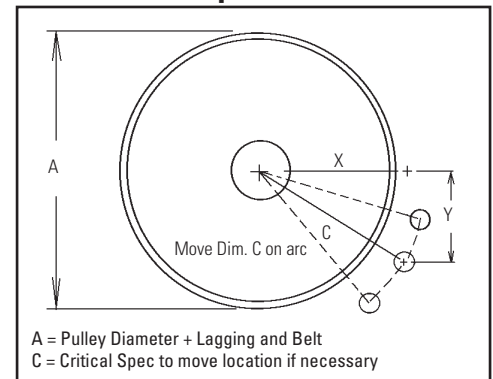

### EST Spring Length Chart

BLADE WIDTH	PURPLE SPRINGS	SILVER SPRINGS	BLACK SPRINGS
mm	mm	mm	mm
250	146	159	N/A
400	133	152	N/A
550	121	149	N/A
700	108	143	N/A
850	N/A	137	143
1000	N/A	130	140
1150	N/A	127	133
1300	N/A	121	130
1450	N/A	N/A	127
1600	N/A	N/A	121
1750	N/A	N/A	117

Shading indicates preferred spring option

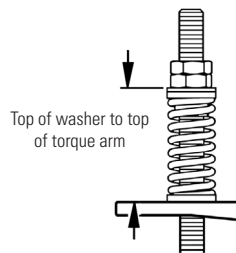

### Pole Location Chart

A	X	Y	C
mm	mm	mm	mm
250	74	230	242
275	92	230	248
300	108	230	254
325	131	230	265
350	146	230	273
375	166	230	284
400	179	230	291
425	195	230	301
450	207	230	309
475	223	230	320
500	235	230	329
525	249	230	339
550	266	230	352
575	283	230	365
600	299	230	377
625	314	230	390
650	330	230	402
675	346	230	415
700	360	230	427
725	374	230	439
750	389	230	452
775	403	230	464
800	417	230	477
825	432	230	489
850	446	230	501
875	460	230	514
900	474	230	526

### Specifications:

- Maximum Belt Speed .....Contact Flexco
- Temperature Rating .....-35 to 82°C
- Minimum Pulley Diameter.....250 mm
- Usable Blade Wear Length.....100 mm
- Blade .....Polyurethane (proprietary blend for abrasion resistance and long wear)
- Available for Belt Widths .....300 to 1800 mm

# Replacement Parts List

## EZP1 Standard Duty Primary Cleaner

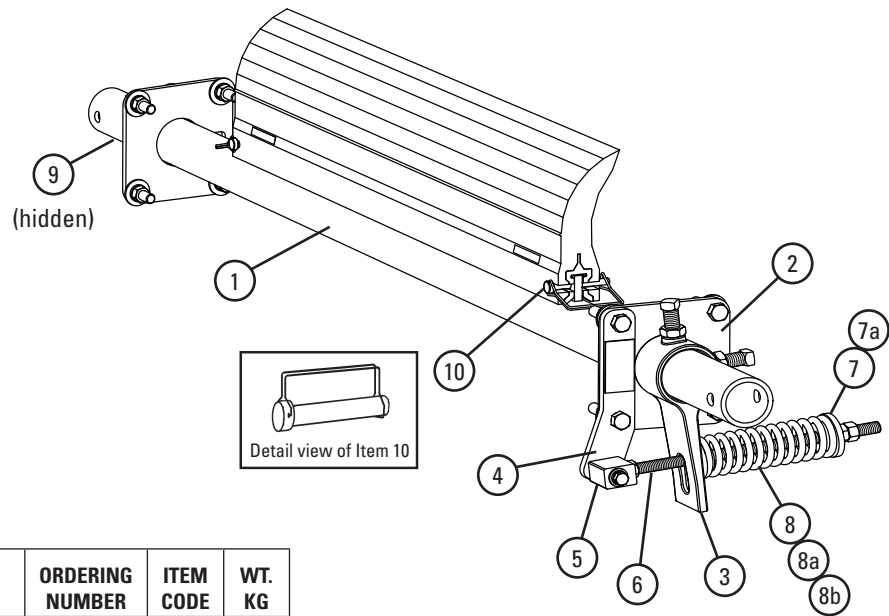

### Replacement Parts

REF	DESCRIPTION	ORDERING NUMBER	ITEM CODE	WT. KG
1	300mm Pole	EZP1P12	75619	7.9
	450mm Pole	EZP1P18	75620	9.2
	600mm Pole	EZP1P24	75621	10.3
	750mm Pole	EZP1P30	75622	12.1
	900mm Pole	EZP1P36	75623	13.8
	1050mm Pole	EZP1P42	75624	14.9
	1200mm Pole	EZP1P48	75625	16.1
	1350mm Pole	EZP1P54	75626	17.8
	1500mm Pole	EZP1P60	75627	19.7
	1800mm Pole	EZP1P72	75772	21.9
2	Mounting Plate Kit* (2 ea.)	EZP1MPK	75637	3.5
3	Torque Arm Kit* (1 ea.)	ESTAK	76406	1.6
4	Pivot Shaft Bracket Kit* (1 ea.)	ESPSBK	76407	0.8
5	Pivot Block Kit*	ESPBK	76408	0.3
6	Pivot Rod Kit*	ESPRK	76409	0.6
7	Bushing Kit - Purple and Silver (includes 2 bushings)	ESBK-PS	76410	0.1
7a	Bushing Kit - Black (includes 2 bushings)	ESBK-B	76411	0.1
8	Tension Spring - Purple	QMTS-P	75845	0.5
8a	Tension Spring - Silver	ESS-S	76412	0.6
8b	Tension Spring - Black	ESS-B	76413	0.6
9	Pole Lock* (1 ea.)	EZP1PL	75641	0.5
-	EST Tensioner - Purple* for blade widths 300-700mm (includes 1 each items 2, 3, 4, 5, 6, 7, 8 & 9)	EST-P	109467	3.5
-	EST Tensioner - Silver* for blade widths 850-1300mm (includes 1 each items 2, 3, 4, 5, 6, 7, 8a & 9)	EST-S	109468	3.6
-	EST Tensioner - Black* for blade widths 1450-1750mm (includes 1 each items 2, 3, 4, 5, 6, 7a, 8b & 9)	EST-B	109469	3.7
10	Blade Pin (1 ea.)	EZP1BP	75642	0.1

\*Hardware Included

### Spring Tensioner Selection Chart

CLEANER BLADE WIDTH	109467 EST-P	109468 EST-S	109469 EST-B
ConShear™ 300-700mm	X		
ConShear 850-1300mm		X	
ConShear 1450-1750mm			X

Stock items (non-shaded) refer to (\*) for specific lead time, if not specified, standard lead time applies.  
Non-stock items (shaded) please contact Flexco for dispatch options and lead times.

# Replacement Parts List

## EZP1 Stainless Steel Primary Cleaner

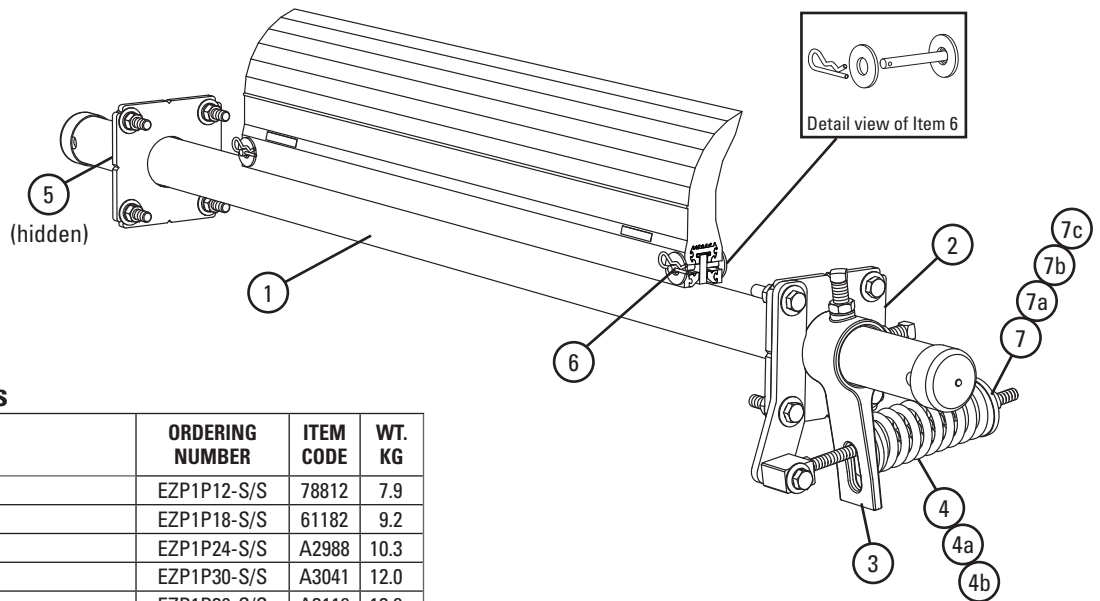

### Replacement Parts

REF	DESCRIPTION	ORDERING NUMBER	ITEM CODE	WT. KG
1	300mm S/S Pole	EZP1P12-S/S	78812	7.9
	450mm S/S Pole	EZP1P18-S/S	61182	9.2
	600mm S/S Pole	EZP1P24-S/S	A2988	10.3
	750mm S/S Pole	EZP1P30-S/S	A3041	12.0
	900mm S/S Pole	EZP1P36-S/S	A3119	13.8
	1050mm S/S Pole	EZP1P42-S/S	61183	14.9
	1200mm S/S Pole	EZP1P48-S/S	61491	16.0
	1350mm S/S Pole	EZP1P54-S/S	61184	17.8
	1500mm S/S Pole	EZP1P60-S/S	61185	19.7
	1800mm S/S Pole	EZP1P72-S/S	61186	21.9
2	SS Mounting Plate Kit* (2 ea.)	EZP1MPK-S/S	78923	3.5
3	SS Torque Arm Kit* (1 ea.)	ESTAK-EST-S/S	78849	1.6
4	SS Tension Spring - Purple	QMTS-P-S/S	77450	0.5
4a	SS Tension Spring - White	QMTS-W-S/S	77451	0.5
4b	SS Tension Spring - Gold	QMTS-G-S/S	77452	0.6
5	SS Pole Lock* (1 ea.)	EZP1PL-S/S	78848	0.5
6	Blade Pin (1 ea.)	MSPBPK-S/S	77583	0.05
7	Bushing Kit - Purple and Silver (includes 2 bushings)	ESBK-PS	76410	0.1
7a	Bushing Kit - Black (includes 2 bushings)	ESBK-B	76411	0.1
7b	EST Bushing Kit - UHT, Purple & White Spring (includes 2 bushings)	ESBK-ATEX	90264	0.05
7c	EST Bushing Kit - UHT, Gold Spring (includes 2 bushings)	ESBK-B EST	76411	0.05
-	SS EST Tensioner - Purple* for blade widths 300-700mm (includes 1 each items 2, 3, 4 & 5)	EST-P-S/S	78808	3.5
-	SS EST Tensioner - White* for blade widths 850-1300mm (includes 1 each items 2, 3, 4a & 5)	EST-W-S/S	78809	3.6
-	SS EST Tensioner - Gold* for blade widths 1450-1750mm (includes 1 each items 2, 3, 4b & 5)	EST-G-S/S	78810	3.7
-	EST S/S UHT Tensioner - Purple* for blade widths 300-700mm (includes items 2, 3, 4, 5 & 7b)	EST-P-S/S-UHT	66993	4.0
-	EST S/S UHT Tensioner - White* for blade widths 850-1300mm (includes items 2, 3, 4a, 5 & 7b)	EST-W-S/S-UHT	66994	4.1
-	EST S/S UHT Tensioner - Gold* for blade widths 1450-1750mm (includes items 2, 3, 4b, 5 & 7c)	EST-G-S/S-UHT	66995	4.2

\*Hardware Included

### Stainless Steel Spring Tensioner Selection Chart

CLEANER BLADE WIDTH	78808 EST-P-S/S	78809 EST-W-S/S	78810 EST-G-S/S
ConShear™ 300-700mm	X		
ConShear 850-1300mm		X	
ConShear 1450-1750mm			X

Stock items (non-shaded) refer to (\*) for specific lead time, if not specified, standard lead time applies.  
Non-stock items (shaded) please contact Flexco for dispatch options and lead times.

# Replacement Parts List

## EZP1 Standard Duty Primary Cleaner and EZP1 Stainless Steel Primary Cleaner

### ConShear™ Replacement Blades

BELT WIDTH	BLADE COVERAGE	ORDERING NUMBER	ITEM CODE	WT. KG
mm	mm			
450	400	CRB16	75629	3.3
600	550	CRB22	75630	4.6
750	700	CRB28	75631	5.8
900	850	CRB34	75632	7.1
1050	1000	CRB40	75633	8.0
1200	1150	CRB46	75634	9.6
1350	1300	CRB52	75635	10.8
1500	1450	CRB58	75636	12.1
1650	1600	CRB64	75775	13.3
1800	1750	CRB70	75773	14.6

Other blade sizes available upon request.

### ConShear™ High Temp Replacement Blades

BELT WIDTH	BLADE COVERAGE	ORDERING NUMBER	ITEM CODE	WT. KG
mm	mm			
300	250	CRB-HT10	76593	2.2
450	400	CRB-HT16	76594	3.5
600	550	CRB-HT22	76595	4.7
750	700	CRB-HT28	76596	6
900	850	CRB-HT34	76597	7.4
1050	1000	CRB-HT40	76598	8.7
1200	1150	CRB-HT46	76599	13
1350	1300	CRB-HT52	76600	11.3
1500	1450	CRB-HT58	76601	12.6
1650	1600	CRB-HT64	76602	13.9
1800	1750	CRB-HT70	76603	15.2

### White ConShear™ Replacement Blades (Chemical Resistant/Food Grade) ‡

BELT WIDTH	BLADE COVERAGE	ORDERING NUMBER	ITEM CODE	WT. KG
mm	mm			
450	400	CRB-W16	78472	3.3
600	550	CRB-W22	78473	4.6
750	700	CRB-W28	78474	5.8
900	850	CRB-W34	78475	7.1
1050	1000	CRB-W40	78476	8.0
1200	1150	CRB-W46	78477	9.6
1350	1300	CRB-W52	78478	10.8
1500	1450	CRB-W58	78479	12.1
1650	1600	CRB-W64	78480	13.3
1800	1750	CRB-W70	78481	14.6

‡ All ingredients used in the polyurethane formulation of this blade comply with the relevant requirements of 21 CFR (FDA Code of Federal Regulations) for use in repeated bulk dry food applications

### Ultra High-Temp ConShear™ Replacement Blades

BELT WIDTH	BLADE COVERAGE	ORDERING NUMBER	ITEM CODE	WT. KG
mm	mm			
450	400	CRB-UHT-400	91254	3.3
600	550	CRB-UHT-550	91255	4.6
750	700	CRB-UHT-700	91256	5.8
900	850	CRB-UHT-850	91257	7.0
1050	1000	CRB-UHT-1000	91258	8.3
1200	1150	CRB-UHT-1150	91259	9.5
1350	1300	CRB-UHT-1300	91260	10.8
1500	1450	CRB-UHT-1450	91261	12.0
1800	1750	CRB-UHT-1750	91263	14.5

Stock items (non-shaded) refer to (\*) for specific lead time, if not specified, standard lead time applies.  
Non-stock items (shaded) please contact Flexco for dispatch options and lead times.

# Product Ordering Information

## EZP1T Twist Tensioner Primary Cleaner



### EZP1T Primary Cleaner with Twist Tensioner Belt Width Minus 50 mm

BELT WIDTH	BLADE WIDTH	ORDERING NUMBER	ITEM CODE	WT. KG
mm	mm			
300	250	EZP1T-212	78488	38.5
450	400	EZP1T-218	78489	44.5
600	550	EZP1T-224	78490	50.5
750	700	EZP1T-230	78491	56.5
900	850	EZP1T-236	78492	62.5
1050	1000	EZP1T-242	78493	68.4
1200	1150	EZP1T-248	78494	74.4
1350	1300	EZP1T-254	78495	83.7
1500	1450	EZP1T-260	78496	92.0
1800	1750	EZP1T-272	78497	101.6

### Product Notes:

- For optimal cleaning and reduced blade retensioning maintenance, the cleaner blade width should be sized to fit the material path of the belt. The material path is typically 2/3 of the belt width. In most cases a blade size of belt width minus 200 mm may be the best selection.
- Each cleaner can be retrofitted with three replacement blade sizes (belt width minus 50 mm, minus 200 mm, or minus 350 mm).
- Comes complete with universal mounting plates and tensioner.
- Visual tension check. No guesswork on blade tensioning. Simply measure the spring, check label on tensioner and turn adjusting nut to restore optimal tension.
- Works with mechanical splices. Polyurethane blade glides over splices.
- Compatible with reversing belts.
- For applications requiring longer pole lengths, go to the minus 200 mm chart and select the cleaner one belt width size larger. This will provide a pole 150 mm longer and a blade size of belt width minus 50 mm.

Stock items (non-shaded) refer to (\*) for specific lead time, if not specified, standard lead time applies.

Non-stock items (shaded) please contact Flexco for dispatch options and lead times.



# Replacement Parts List

## EZP1T Twist Tensioner Primary Cleaner

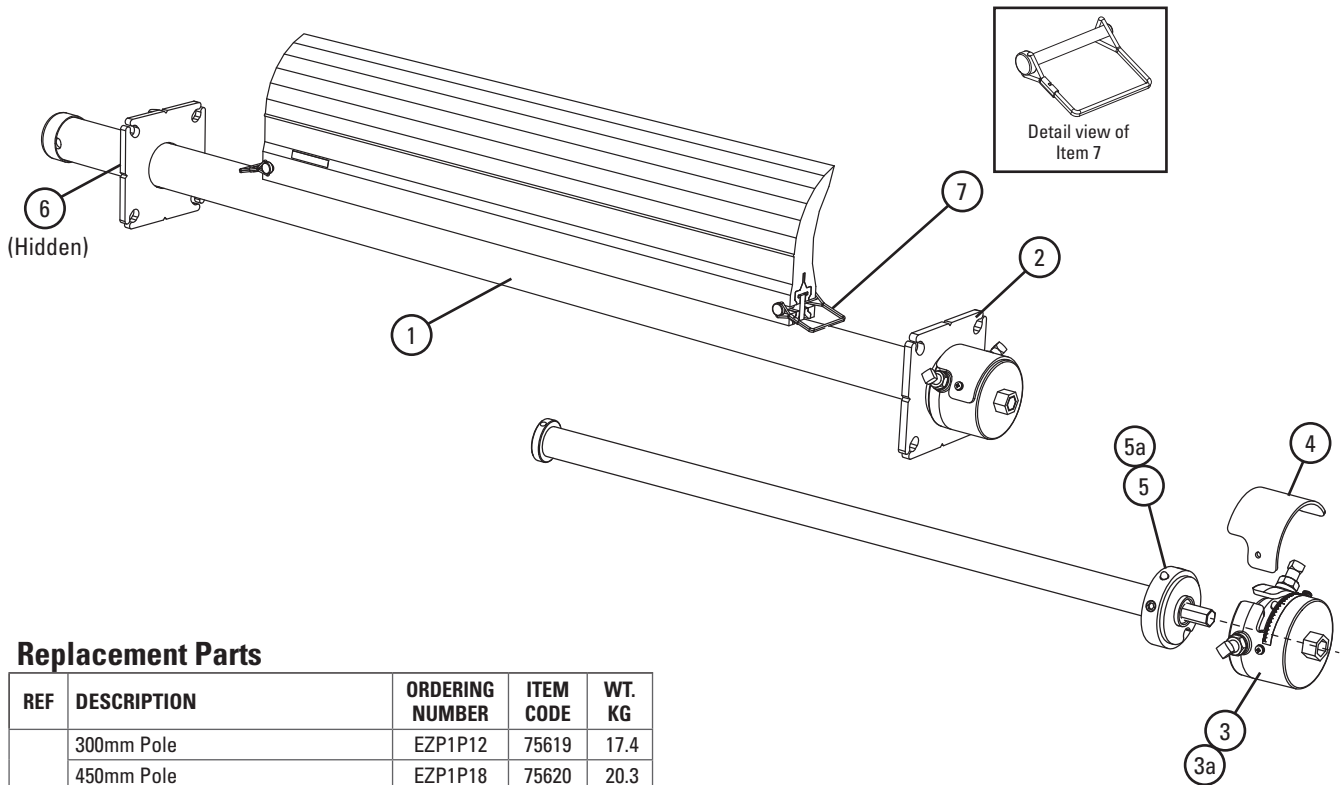

### Replacement Parts

REF	DESCRIPTION	ORDERING NUMBER	ITEM CODE	WT. KG
1	300mm Pole	EZP1P12	75619	17.4
	450mm Pole	EZP1P18	75620	20.3
	600mm Pole	EZP1P24	75621	22.7
	750mm Pole	EZP1P30	75622	26.5
	900mm Pole	EZP1P36	75623	30.4
	1050mm Pole	EZP1P42	75624	32.7
	1200mm Pole	EZP1P48	75625	35.3
	1350mm Pole	EZP1P54	75626	39.2
	1500mm Pole	EZP1P60	75627	43.3
	1800mm Pole	EZP1P72	75772	48.2
2	Torsion Mounting Plate Kit* (2 ea.)	EZPTMPK	78507	8.7
3	Torsion Cap Kit* (1 ea.) (includes 1 ea. Item 4)	EZPTCK	78508	3.2
3a	Torsion Cap Kit HD* (1 ea.) (includes 1 ea. Item 4)	EZPTCKHD	78509	3.2
4	Torsion Shield	EZPTSR	78510	.1
5	Torsion Spring Kit	EZPTSK	78511	6.0
5a	Torsion Spring Kit HD	EZPTSKHD	78512	8.5
6	Pole Lock* (1 ea.)	EZP1PL	75641	1.1
-	Torsion Bar Tensioner for blade widths 300–1200mm (includes 1 each items 3, 4, & 5)	EZPTBT	77384	17.4
-	Torsion Bar Tensioner HD for blade widths 1350–1800mm (includes 1 each items 3a, 4, & 5a)	EZPTBTHD	77385	20.0
7	Blade Pin (1 ea.)	EZP1BP	75642	0.1

\*Hardware Included

### Torsion Bar Tensioner Selection Chart

CLEANER BLADE WIDTH	77384 EZPTBT	77385 EZPTBTHD
ConShear 300–1200mm	X	
ConShear 1350–1800mm		X

Stock items (non-shaded) refer to (\*) for specific lead time, if not specified, standard lead time applies.  
Non-stock items (shaded) please contact Flexco for dispatch options and lead times.

# Product Ordering Information

## Spring Covers and Tensioner Lock

### Spring Covers

ORDERING NUMBER	ITEM CODE	WT. KG
SPG-CVR-A	77387	0.14
SPG-CVR-B	77388	0.14
SPG-CVR-C	77389	0.14
SPG-CVR-D	77390	0.18
SPG-CVR-E	77391	0.18
SPG-CVR-F	77392	0.14
SPG-CVR-G	77393	0.14
SPG-CVR-H	77741	0.14

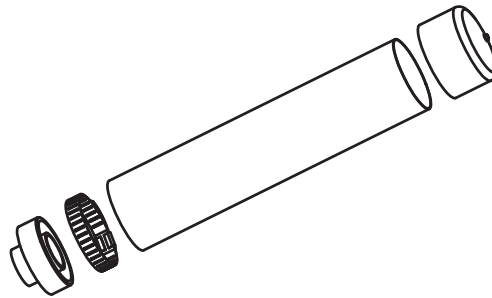

### Tensioner Lock

Designed to prevent tampering or unauthorized retensioning of the cleaner.

ORDERING NUMBER	ITEM CODE	WT. KG
TEN-LOCK-KIT	77443	0.18

\*For MSP, MMP, MHP, MHCP, H-Type® Primary Cleaner and MSS, MHS, MDWS Secondary Cleaners  
Includes 1 tensioner lock

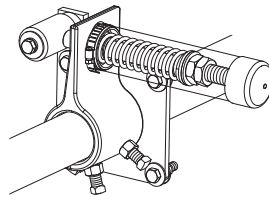

Spring cover on Primary Cleaner tensioner

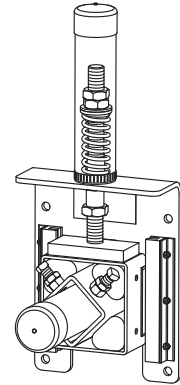

Spring cover on Secondary cleaner tensioner

### Spring Cover Selection Chart

TENSIONER	SPRING COVER REQ'D
EST-P	77387
EST-S	77387
EST-B	77388
QMT-P	77389
QMT-W	77390
QMT-G	77391
QMT-S	77391
PST-R	77391
PST-W	77390
PST-S	77390
SST-W	77392
SST-S	77392
SST-B	77393
SST-G	77392
UST-P	77387
UST-S	77387
UST-W	77390
CST-W	77741
CST-S	77741
CST-B	77741
CST-G	77741

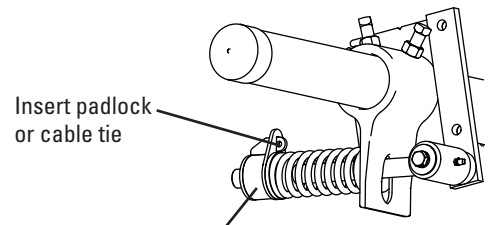
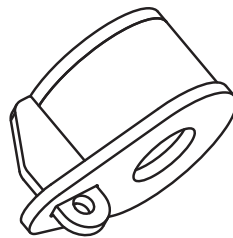

Tensioner Lock

(Primary Cleaner tensioner shown)

Stock items (non-shaded) refer to (\*) for specific lead time, if not specified, standard lead time applies.  
Non-stock items (shaded) please contact Flexco for dispatch options and lead times.

# Product Ordering Information

## MMP Medium Mine-Duty Primary Cleaner

### MMP Medium-Duty Primary Cleaner Belt Width Minus 150 mm Blade

BELT WIDTH	BLADE COVERAGE	ORDERING NUMBER	ITEM CODE	WT. KG
mm	mm			
600	450	MMP-624	76450	72.4
750	600	MMP-630	76451	79.6
900	750	MMP-636	76452	86.6
1050	900	MMP-642	76453	93.7
1200	1050	MMP-648	76454	100.8
1350	1200	MMP-654	76455	107.9
1500	1350	MMP-660	76456	115.0
1800	1650	MMP-672	76457	132.3
2100	1950	MMP-684	76798	156.4



### Product Notes:

- Recommended for medium-duty conveyor applications. For abusive applications see the MHP Heavy-Duty Primary Cleaner or the MHCP Heavy-Duty Cartridge Primary Cleaner.
- Pole Length: Belt width plus 1350 mm. For longer requirements see Installation Accessories - Pole Extender Kit.
- Visual Tension Check: No guesswork on blade tensioning. Measure the spring and adjust to specified length per blade width to restore optimal tensioning.

### Stainless Steel MMP Medium-Duty Primary Cleaner Belt Width Minus 150 mm Blade

BELT WIDTH	BLADE COVERAGE	ORDERING NUMBER	ITEM CODE
mm	mm		
600	450	MMP-624-S/S	77424
750	600	MMP-630-S/S	77425
900	750	MMP-636-S/S	77426
1050	900	MMP-642-S/S	77427
1200	1050	MMP-648-S/S	77428
1350	1200	MMP-654-S/S	77429
1500	1350	MMP-660-S/S	77430
1800	1650	MMP-672-S/S	77431
2100	1950	MMP-684-S/S	77432



### Product Notes:

- Recommended for medium-duty conveyor applications, but in corrosive environments.
- Material Path Option: Fit the blade width to the belt's material path. The material path is typically the center 2/3 of the belt width. In most cases a blade size of belt width minus 150 mm may be the best solution.
- Each cleaner pole is retrofittable for three blade sizes (belt width minus 150 mm, minus 300 mm or minus 450 mm).
- Pole Length: Belt width plus 1372 mm. For longer requirements see Installation Accessories - Pole Extender Kit.
- Visual Tension Check: No guesswork on blade tensioning. Measure the spring and adjust to specified length per blade width to restore optimal tensioning.
- To make cleaner installation easier and quicker, see Optional Mounting Kits.

Stock items (non-shaded) refer to (\*) for specific lead time, if not specified, standard lead time applies.  
 Non-stock items (shaded) please contact Flexco for dispatch options and lead times.

# Product Ordering Information

## MMP Medium Mine-Duty Primary Cleaner

### Blade Width Selection

BELT WIDTH mm	ITEM CODE		
	BELT WIDTH MINUS 150mm	BELT WIDTH MINUS 300mm	BELT WIDTH MINUS 450mm
600	76485	N/A	N/A
750	76486	76485	N/A
900	76487	76486	76485
1050	76488	76487	76486
1200	76489	76488	76487
1350	76490	76489	76488
1500	76491	76490	76489
1800	76493	76492	76491
2100	76697	76494	76493
2400	77048	77047	76697

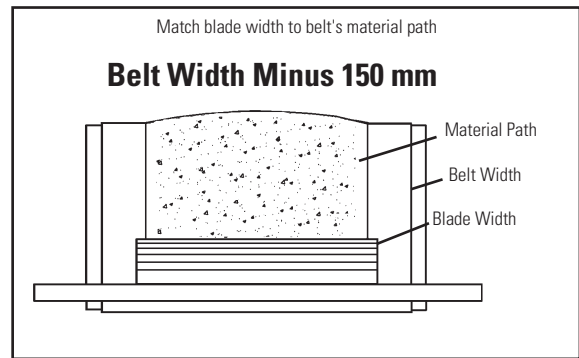

## Replacement Parts List

### Replacement TuffShear™ Blades

REF	BLADE WIDTH	ORDERING NUMBER	ITEM CODE	WT. KG
	mm			
10	450	TRB18	76485	9.6
	600	TRB24	76486	12.7
	750	TRB30	76487	16.0
	900	TRB36	76488	19.1
	1050	TRB42	76489	22.3
	1200	TRB48	76490	25.5
	1350	TRB54	76491	28.6
	1500	TRB60	76492	31.8
	1650	TRB66	76493	35.0
	1800	TRB72	76494	38.2
	1950	TRB78	76697	41.4
	2100	TRB84	77047	44.5
2400	TRB90	77048	47.6	

Order blade width for your belt width's material path:  
Belt Width Minus 152 mm, Belt Width Minus 305 mm,  
or Belt Width Minus 457 mm.

**Stock items** (non-shaded) refer to (\*) for specific lead time, if not specified, standard lead time applies.

**Non-stock items** (shaded) please contact Flexco for dispatch options and lead times.

# Replacement Parts List

## MMP Medium Mine-Duty Primary Cleaner

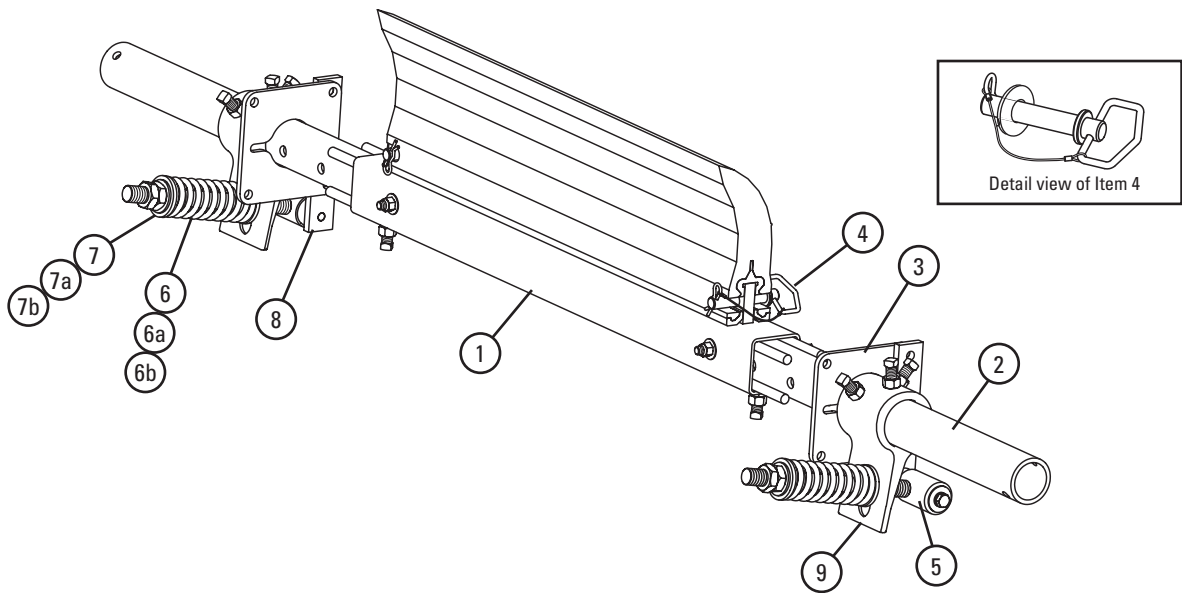

### Replacement Parts - Mild Steel

REF	DESCRIPTION	ORDERING NUMBER	ITEM CODE	WT. KG
1	600mm Pole	MMPCP24	76458	15.6
	750mm Pole	MMPCP30	76459	19.6
	900mm Pole	MMPCP36	76460	23.5
	1050mm Pole	MMPCP42	76461	27.3
	1200mm Pole	MMPCP48	76462	31.2
	1350mm Pole	MMPCP54	76463	35.1
	1500mm Pole	MMPCP60	76464	39.1
	1800mm Pole	MMPCP72	76465	46.9
	2100mm Pole	MMPCP84	76808	54.7
2	Extender Pole Kit (2 ea.)	MHP-EP	76392	24.6
3	Mounting Plate Kit* (2 ea.)	MSPMPK	75811	3.8
4	Blade Pin Kit* (1 ea.)	MMPBPK	76466	0.4
5	Pivot Arm Kit* (1 ea.)	QMTPAK	76096	2.0
6	Tension Spring - Purple (1 ea.) for blades 600mm	QMTS-P	75845	0.3
6a	Tension Spring - White (1 ea.) for blades 750–1200mm	PSTS-W	75898	0.8
6b	Tension Spring - Gold (1 ea.) for blades 1350–1950mm	QMTS-G	76484	1.1
7	Bushing Kit - Purple (2 ea.)	QMTBK-P	76097	0.1
7a	Bushing Kit - White (2 ea.)	QMTBK-W	76098	0.1
7b	Bushing Kit - Gold (2 ea.)	QMTBK-G	76540	0.1
8	Pivot Shaft Bracket Kit* (1 ea.)	QMTPSBK	76099	2.0
9	Torsion Arm Kit* (1 ea.)	PSTA	75896	5.2
-	QMT Spring Tensioner* - Purple (incl. 1 ea. Items 5, 6, 7, 8, & 9) for blades 450–600mm	QMT-P	76074	9.3
-	QMT Spring Tensioner* - White (incl. 1 ea. Items 5, 6a, 7a, 8, & 9) for blades 750–1200mm	QMT-W	76075	10.0
-	QMT Spring Tensioner* - Gold (incl. 1 ea. Items 5, 6b, 7b, 8, & 9) for blades 1350–1950mm	QMT-G	76483	10.6

\*Hardware Included

### Replacement Parts - Stainless Steel

REF	DESCRIPTION	ORDERING NUMBER	ITEM CODE
1	600mm SS Pole	MMPCP24-S/S	77590
	750mm SS Pole	MMPCP30-S/S	77591
	900mm SS Pole	MMPCP36-S/S	77592
	1050mm SS Pole	MMPCP42-S/S	77593
	1200mm SS Pole	MMPCP48-S/S	77594
	1350mm SS Pole	MMPCP54-S/S	77595
	1500mm SS Pole	MMPCP60-S/S	77596
	1800mm SS Pole	MMPCP72-S/S	77597
	2100mm SS Pole	MMPCP84-S/S	77598
2	SS Extender Pole Kit (2 ea.)	MHP-EP-S/S	77599
3	SS Mounting Plate Kit* (2 ea.)	MSPMPK-S/S	77582
4	SS Blade Pin Kit* (1 ea.)	MMPBPK-S/S	77600
5	SS Pivot Arm Kit* (1 ea.)	QMTPAK-S/S	77587
6	SS Tension Spring - Purple (1 ea.) for blades 600mm	QMTS-P-S/S	77450
6a	SS Tension Spring - White (1 ea.) for blades 750–1200mm	QSTS-W-S/S	77451
6b	SS Tension Spring - Gold (1 ea.) for blades 1350–1950mm	QMTS-G-S/S	77452
7	Bushing Kit - Purple (2 ea.)	QMTBK-P	76097
7a	Bushing Kit - White (2 ea.)	QMTBK-W	76098
7b	Bushing Kit - Gold (2 ea.)	QMTBK-G	76540
8	SS Pivot Shaft Bracket Kit* (1 ea.)	QMTPSBK-S/S	77588
9	SS Torsion Arm Kit* (1 ea.)	PSTA-S/S	77442
-	SS QMT Spring Tensioner* - Purple (incl. 1 ea. Items 5, 6, 7, 8, & 9) for blades 450–600mm	QMT-P-S/S	77584
-	SS QMT Spring Tensioner* - White (incl. 1 ea. Items 5, 6a, 7a, 8, & 9) for blades 750–1200mm	QMT-W-S/S	77585
-	SS QMT Spring Tensioner* - Gold (incl. 1 ea. Items 5, 6b, 7b, 8, & 9) for blades 1350–1950mm	QMT-G-S/S	77586

\*Hardware Included

Stock items (non-shaded) refer to (\*) for specific lead time, if not specified, standard lead time applies.  
Non-stock items (shaded) please contact Flexco for dispatch options and lead times.



# Specifications & Guidelines

## MMP Medium Mine-Duty Primary Cleaner

### Pole Length Specifications\*

BELT WIDTH	MAX OVERALL POLE LENGTH	CENTRE POLE LENGTH	MAXIMUM CONVEYOR SPAN
mm	mm	mm	mm
600	1950	600	1650
750	2100	750	1800
900	2250	900	1950
1050	2400	1050	2100
1200	2550	1200	2250
1350	2700	1350	2400
1500	2850	1500	2550
1800	3150	1800	2850
2100	3450	2100	3150

\*For special extra long pole length requirements a Pole Extender Kit (#76024) is available that provides 750 mm of extended pole length. Pole Diameter -73 mm

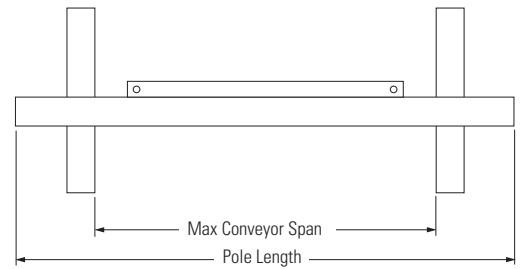

### Clearance Guidelines for Installation

HORIZONTAL CLEARANCE REQUIRED	VERTICAL CLEARANCE REQUIRED
mm	mm
100	325

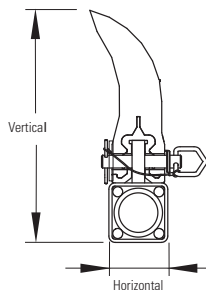

### Pole Location Specs

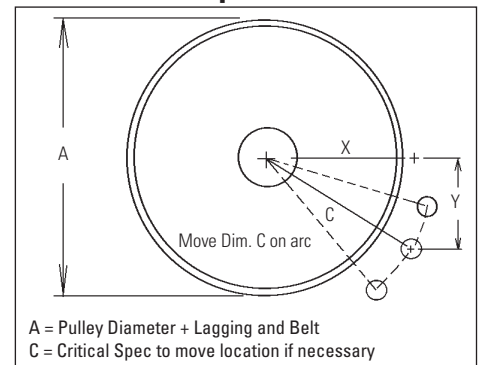

### QMT Spring Length Chart

BLADE WIDTH	PURPLE SPRINGS	WHITE SPRINGS	GOLD SPRINGS
mm	mm	mm	mm
450	110	150	160
600	100	140	150
750	N/A	140	150
900	N/A	130	150
1050	N/A	130	140
1200	N/A	130	140
1350	N/A	120	140
1500	N/A	120	140
1650	N/A	N/A	130
1800	N/A	N/A	130
1950	N/A	N/A	130
2100	N/A	N/A	N/A
2250	N/A	N/A	N/A

Shading indicates preferred spring option

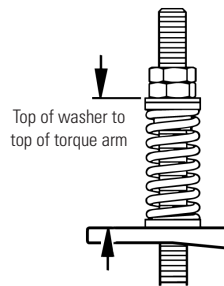

### Pole Location Chart

A	X	Y	C
mm	mm	mm	mm
406	207	305	368
432	222	305	378
457	235	305	384
483	248	305	394
508	264	305	403
533	279	305	413
559	292	305	422
584	305	305	432
610	321	305	441
635	334	305	451
660	346	305	461
686	359	305	470
711	372	305	480
737	387	305	492
762	397	305	502
787	410	305	511
813	425	305	524
838	438	305	533
864	451	305	543
889	464	305	556
914	476	305	565
940	492	305	578
965	502	305	588
991	518	305	600
1016	527	305	610
1041	543	305	622
1067	552	305	632
1092	568	305	645
1118	578	305	654
1143	594	305	667
1168	607	305	679
1194	619	305	689
1219	632	305	702

### Specifications:

- Maximum Belt Speed ..... Contact Flexco
- Temperature Rating ..... -35 to 82°C
- Minimum Pulley Diameter..... 400 mm
- Usable Blade Wear Length..... 150 mm
- Blade ..... Polyurethane (proprietary blend for abrasion resistance and long wear)
- Available for Belt Widths ..... 600 to 2100 mm  
Other sizes available upon request

# Product Ordering Information

## MHP Mine Tough Heavy-Duty Primary Cleaner

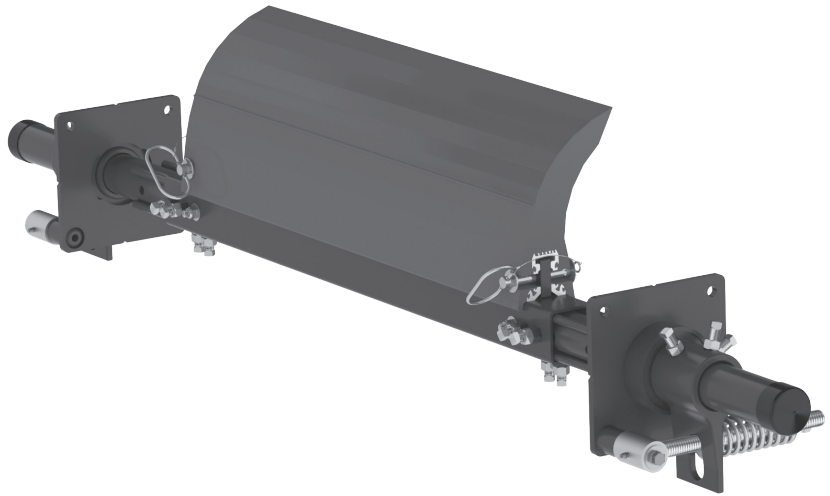

### Belt Width Minus 150 mm

BELT WIDTH	BLADE WIDTH	ORDERING NUMBER	ITEM CODE	WT. KG
mm	mm			
600	450	MHP-624	77703	113.1
750	600	MHP-630	77704	121.4
900	750	MHP-636	77705	129.6
1050	900	MHP-642	77706	137.9
1200	1050	MHP-648	77707	146.1
1350	1200	MHP-654	77708	155.0
1500	1350	MHP-660	77709	163.2
1800	1650	MHP-672	77710	179.8
2100	1950	MHP-684	77711	196.4
2400	2250	MHP-696	77712	212.9
2700	2550	MHP-6108	90151	229.5
3050	2850	MHP-6120	90152	246.0

### Product Notes:

- Recommended for heavy-duty conveyor applications.
- Material Path Option: Fit the blade width to the belt's material path. The material path is typically the center 2/3 of the belt width.  
In most cases a blade size of belt width minus 150 mm may be the best solution.
- Each cleaner pole is retrofittable for blade sizes down to 450 mm in 150 mm increments.
- Pole Length: Belt width plus 1350 mm.
- Visual Tension Check: No guesswork on blade tensioning. Measure the spring and adjust to specified length per blade width to restore optimal tensioning.

Stock items (non-shaded) refer to (\*) for specific lead time, if not specified, standard lead time applies.

Non-stock items (shaded) please contact Flexco for dispatch options and lead times.

# Product Ordering Information

**MegaShear™**  
Replacement Blades



## MegaShear™ Replacement Blades

BLADE WIDTH	ORDERING NUMBER	ITEM CODE	WT. KG
mm			
450	MRB18	77531	13.1
600	MRB24	77532	17.5
750	MRB30	77533	21.8
900	MRB36	77534	26.2
1050	MRB42	77535	30.6
1200	MRB48	77536	34.9
1350	MRB54	77537	39.3
1500	MRB60	77538	43.7
1650	MRB66	77539	48.0
1800	MRB72	77540	52.4
1950	MRB78	77541	56.7
2100	MRB84	77542	61.1
2250	MRB90	77543	65.5
2400	MRB96	77544	69.8
2550	MRB102	77545	74.2
2700	MRB108	77546	78.5
2850	MRB114	77547	82.9

Other blade sizes available upon request.

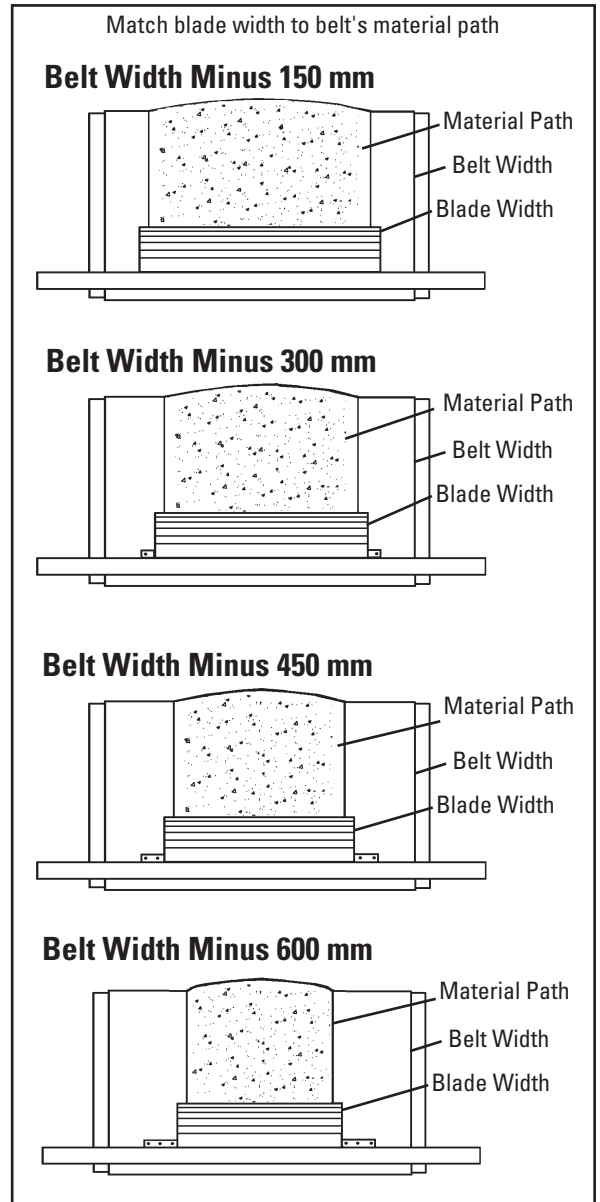

### Product Notes:

- A molded-in wear line indicates when the blade is worn out and needs to be replaced.
- Faceted blade profile: Renews its cleaning edge as the blade wears.
- MegaShear™ blades are made of a special long-wearing polyurethane.
- Quick blade replacement: Pull one pin, remove the old blade and slide the new one in.

# Product Ordering Information

## MHCP Heavy-Duty Cartridge Primary Cleaner

### MHCP HD Cartridge Primary Cleaner with Spring Tensioner (PST)

BELT WIDTH	BLADE COVERAGE	ORDERING NUMBER	ITEM CODE	WT. KG
mm	mm			
600	450	MHCP-24S	75929	87.3
750	600	MHCP-30S	75930	94.2
900	750	MHCP-36S	75931	101.1
1050	900	MHCP-42S	75932	107.9
1200	1050	MHCP-48S	75933	114.8
1350	1200	MHCP-54S	75934	121.6
1500	1350	MHCP-60S	75935	128.5
1800	1650	MHCP-72S	75936	142.2
2100	1950	MHCP-84S	76800	165.9



### MHCP HD Cartridge Primary Cleaner with Air/Water Tensioner (AWT)\*

BELT WIDTH	BLADE COVERAGE	ORDERING NUMBER	ITEM CODE	WT. KG
mm	mm			
600	450	MHCP-24A	75937	87.4
750	600	MHCP-30A	75938	94.2
900	750	MHCP-36A	75939	101.1
1050	900	MHCP-42A	75940	107.9
1200	1050	MHCP-48A	75941	114.8
1350	1200	MHCP-54A	75942	121.6
1500	1350	MHCP-60A	75943	128.5
1800	1650	MHCP-72A	75944	142.2
2100	1950	MHCP-84A	76801	165.9



### Product Notes:

- Heavy-duty design with massive SuperShear™ blades for constant cleaning power on abusive beltlines.
- Blade width equals Belt Width minus 150 mm. Can be adjusted to belt's material path.
- Pole Length: Belt Width plus 1450 mm. For longer requirements see Minline® Installation Accessories - Pole Extender Kit.
- Tensioner Options: 1) PST Spring Tensioner for self-adjusting tensioning with easy retensioning adjustments; 2) AWT Air/Water Tensioner for automatic tensioning throughout the life of the blades.

Stock items (non-shaded) refer to (\*) for specific lead time, if not specified, standard lead time applies.  
 Non-stock items (shaded) please contact Flexco for dispatch options and lead times.

# Specifications & Guidelines

## MHCP Heavy-Duty Cartridge Primary Cleaner

### Pole Length Specifications

CLEANER SIZE	MAX OVERALL POLE LENGTH	CENTRE POLE LENGTH	MAXIMUM CONVEYOR SPAN
mm	mm	mm	mm
600	2050	700	1650
750	2200	850	1800
900	2350	1000	1950
1050	2500	1150	2100
1200	2650	1300	2250
1350	2800	1450	2400
1500	2950	1600	2550
1800	3250	1900	2850
2100	3550	2200	3150

Pole Diameter - 73mm

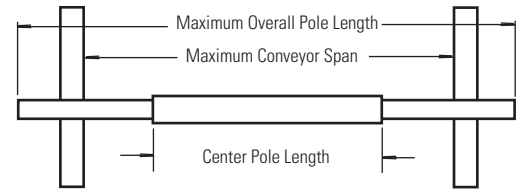

### Pole Location Specs

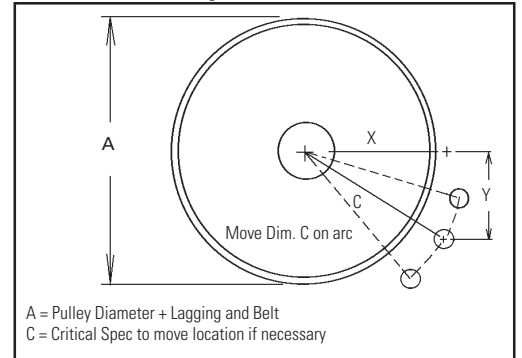

### Clearance Guidelines for Installation

HORIZONTAL CLEARANCE REQUIRED	VERTICAL CLEARANCE REQUIRED
mm	mm
175	475

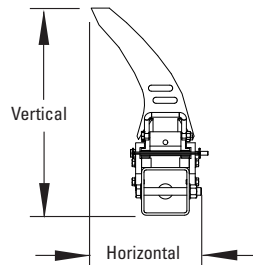

### Pole Location Chart

A	X	Y	C
mm	mm	mm	mm
508	254	365	445
533	267	365	451
559	279	365	461
584	292	365	467
610	305	365	476
635	318	365	483
660	330	365	492
686	343	365	502
711	356	365	511
737	368	365	518
762	381	365	527
787	394	365	537
813	406	365	546
838	419	365	556
864	432	365	565
889	445	365	575
914	457	365	584
940	470	365	594
965	483	365	607
991	495	365	616
1016	508	365	626
1041	521	365	635
1067	533	365	648
1092	546	365	657
1118	559	365	667
1143	572	365	679
1168	584	365	689
1194	591	365	699
1219	610	365	711

### PST Spring Length Chart

Blade Width	White Springs	Silver Springs
mm	mm	mm
450	143	N/A
600	137	159
750	127	156
900	121	152
1050	N/A	152
1200	N/A	149
1350	N/A	146
1500	N/A	143
1650	N/A	143
1800	N/A	140
1950	N/A	137
2100	N/A	N/A

Shading indicates preferred spring option.

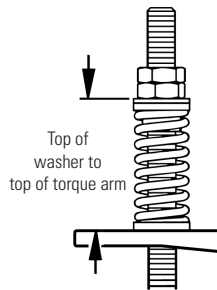

### Air/Water Chart

BLADE WIDTH	No. BLADES	PSI
mm		
450	3	8#
600	4	10#
750	5	13#
900	6	15#
1050	7	18#
1200	8	20#
1350	9	23#
1500	10	25#
1650	11	28#
1950	12	31#

PSI setting is based on the number of blades on the cleaner, not Belt Width.

### Specifications:

- Maximum Belt Speed .....Contact Flexco
- Temperature Rating .....-35 to 82°C
- Minimum Pulley Diameter.....400 mm
- Usable Blade Wear Length.....200 mm
- Blades .....Polyurethane (proprietary blend for abrasion resistance and long wear)
- Available for Belt Widths .....600 to 2100 mm  
Other sizes available upon request.

# Replacement Parts List

## MHCP Heavy-Duty Cartridge Primary Cleaner

### Replacement Parts List

REF	DESCRIPTION	ORDERING NUMBER	ITEM CODE	WT. KG
1	600mm Centre Pole*	MHP-CP600	75961	8.6
	750mm Centre Pole*	MHP-CP750	75962	10.5
	900mm Centre Pole*	MHP-CP900	75963	12.4
	1050mm Centre Pole*	MHP-CP1050	75964	14.2
	1200mm Centre Pole*	MHP-CP1200	75965	16.1
	1350mm Centre Pole*	MHP-CP1400	75966	17.9
	1500mm Centre Pole*	MHP-CP1500	75967	19.8
	1800mm Centre Pole*	MHP-CP1800	75968	23.5
	2100mm Centre Pole*	MHP-CP2100	76811	27.4
2	MHCP Extender Poles (2 ea.)	MHP-EP	76392	24.6
3	SuperShear™ Blade	SSRB	75978	3.0
3a	SuperShear™ FRAS Blade	SSFRB	78456	3.0
4	600mm 2-Piece Blade Cartridge*	MHCP-2BC24	76638	6.0
	750mm 2-Piece Blade Cartridge*	MHCP-2BC30	76639	8.0
	900mm 2-Piece Blade Cartridge*	MHCP-2BC36	76640	10.0
	1050mm 2-Piece Blade Cartridge*	MHCP-2BC42	76641	12.0
	1200mm 2-Piece Blade Cartridge*	MHCP-2BC48	76642	14.0
	1350mm 2-Piece Blade Cartridge*	MHCP-2BC54	76643	16.0
	1500mm 2-Piece Blade Cartridge*	MHCP-2BC60	76644	18.0
	1800mm 2-Piece Blade Cartridge*	MHCP-2BC72	76645	22.0
	2100mm 2-Piece Blade Cartridge*	MHCP-2BC84	76812	25.7
5	MHCP Cartridge Handle*	MHCP-CH	76393	0.2
6	MHCP Cartridge Blade Stop*	MHCP-BS	76394	0.2

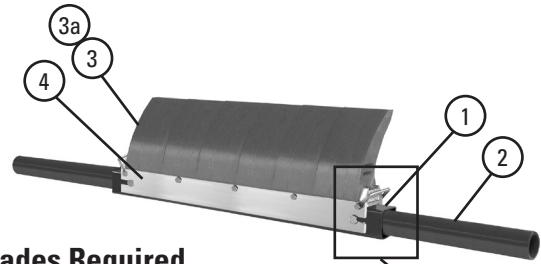

### Blades Required per Belt Width

BELT WIDTH	BLADE COVERAGE	NO. BLADES REQUIRED
mm	mm	
600	450	3
750	600	4
900	750	5
1050	900	6
1200	1050	7
1350	1200	8
1500	1350	9
1800	1650	11
2100	1950	13

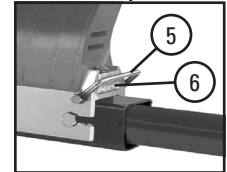

Blades and cartridges can be purchased separately (see chart at left) or preassembled as a Blade Cartridge Kit

### PST Spring Tensioner Replacement Parts

REF	DESCRIPTION	ORDERING NUMBER	ITEM CODE	WT. KG
7	Mounting Base* (1 ea.)	PMB	77727	10.1
8	Torque Arm* (1 ea.)	PSTA	75896	5.1
9	Torque Pivot Kit (1 ea.) (no spring)	PTPK	75897	3.2
10	Tension Spring - White (1 ea.) for belts 600–1200mm	PSTS-W	75898	0.8
10a	Tension Spring - Silver (1 ea.) for belts 1350–2100mm	PSTS-S	75899	1.4
11	Bushing Kit (2 ea.) (for White & Silver Tensioners)	QMTBK-W	76098	0.1
	PST Spring Tensioner* - White (includes 2 each items 7, 8, 9, 10 & 11) for belts 600–1200mm	PST2-W	77723	39.1
	PST Spring Tensioner* - Silver (includes 2 each items 7, 8, 9, 10a & 11) for belts 1350–2100mm	PST2-S	77724	39.2

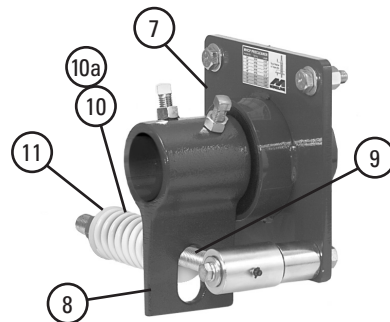

### Air/Water Tensioner Replacement Parts

REF	DESCRIPTION	ORDERING NUMBER	ITEM CODE	WT. KG
12	Air/Water Bag (1 ea.)	AWTB	75905	1.7
13	Mounting Base (1 ea.)	AWTMB	75906	10.4
14	Torque Arm* (1 ea.)	AWTA	75907	5.3
15	Hose Kit (15 M of hose and 6 hose clamps)	AWTHK	75909	3.1
16	Control Box (Complete)	AWTCB	75908	0.5
–	AWT Air/Water Tensioner (includes 2 each items 12, 13, & 14 and 1 each items 15 & 16)	AWT	75904	39.2
–	AWT Air/Water Tensioner w/o Control Box (includes 2 each items 12, 13, 14 & 1 each item 15)	AWTNCB	76069	34.2
–	AWT Air/Water Tensioner w/o Control Box, 1 side (includes 1 each items 12, 13, 14 & 15)	AWT-1S	76375	17.1

\*Hardware Included

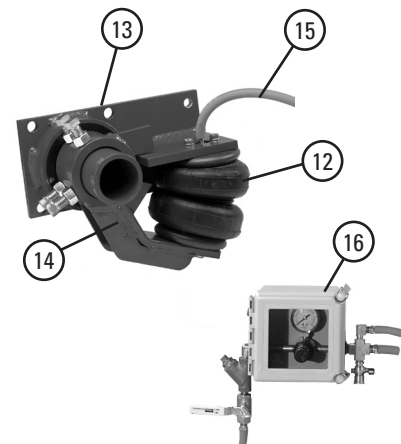

Stock items (non-shaded) refer to (\*) for specific lead time, if not specified, standard lead time applies.  
Non-stock items (shaded) please contact Flexco for dispatch options and lead times.

# Product Ordering Information

## H-Type® with XF-Tips Segmented Blade Primary Cleaner

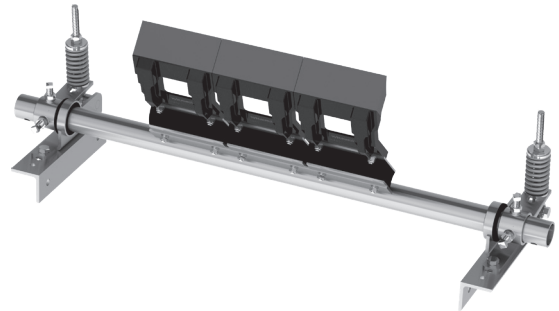
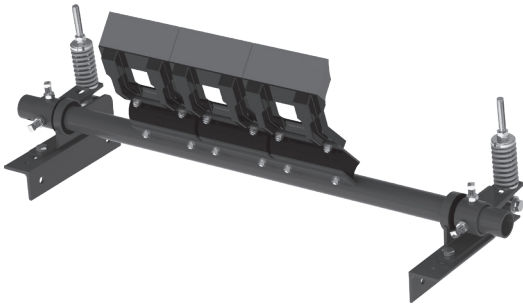

### H-Type® with XF-Tips-Powder Coated

BELT WIDTH	HF-TIP SIZE	ORDERING NUMBER	ITEM CODE	WT. KG
mm				
450	S	HXF450S	74659	35.0
450	M	HXF450M	74660	35.0
600	S	HXF600S	74661	41.0
600	M	HXF600M	74662	41.0
750	S	HXF750S	74663	42.0
750	M	HXF750M	74664	42.0
900	S	HXF900S	74665	47.0
900	M	HXF900M	74666	47.0
900	L	HXF900L	74667	47.0
1050	S	HXF1050S	74668	60.0
1050	M	HXF1050M	74669	60.0
1050	L	HXF1050L	74670	60.0
1200	S	HXF1200S	74671	62.0
1200	M	HXF1200M	74672	62.0
1200	L	HXF1200L	74673	62.0
1500	M	HXF1500M	74677	75.0
1500	L	HXF1500L	74678	75.0
1600	M	HXF1600M	73443	80.0
1600	L	HXF1600L	73444	80.0
1800	M	HXFHD1800M	74681	105.0
1800	L	HXFHD1800L	74682	105.0
2100	M	HXFHD2100M	74683	110.0
2100	L	HXFHD2100L	74684	110.0
2400	M	HXFHD2400M	74685	120.0
2400	L	HXFHD2400L	74686	120.0

### H-Type® with XF-Tips-Stainless Steel

BELT WIDTH	XF2-TIP SIZE	ORDERING NUMBER	ITEM CODE	WT. KG
mm				
450	S	HXF450S-S/S	75266	35.0
450	M	HXF450M-S/S	75267	35.0
600	S	HXF600S-S/S	75268	42.0
600	M	HXF600M-S/S	75269	42.0
750	S	HXF750S-S/S	75270	43.0
750	M	HXF750M-S/S	75271	43.0
900	S	HXF900S-S/S	75272	49.0
900	M	HXF900M-S/S	75273	49.0
900	L	HXF900L-S/S	75274	49.0
1050	S	HXF1050S-S/S	75275	62.0
1050	M	HXF1050M-S/S	75276	62.0
1050	L	HXF1050L-S/S	75277	62.0
1200	S	HXF1200S-S/S	75278	63.0
1200	M	HXF1200M-S/S	75279	63.0
1200	L	HXF1200L-S/S	75280	63.0
1500	M	HXF1500M-S/S	75281	77.0
1500	L	HXF1500L-S/S	75282	77.0
1600	M	HXF1600M-S/S	75283	82.0
1600	L	HXF1600L-S/S	75284	82.0
1800	M	HXFHD1800M-S/S	A1588	107.0
1800	L	HXFHD1800L-S/S	A1589	107.0
2100	M	HXFHD2100M-S/S	A1590	112.0
2100	L	HXFHD2100L-S/S	A1591	112.0
2400	M	HXFHD2400M-S/S	A1592	122.0
2400	L	HXFHD2400L-S/S	A1593	122.0

### Product Notes:

- All cleaners supplied with dual tensioners.
- Also available with J-Bolt Side Assembly.
- Standard supply is non-FRAS.
- Specify when ordering FRAS.
- Specify arm size when ordering.
- Other sizes available on request.

 **Stock items** (non-shaded) refer to (\*) for specific lead time, if not specified, standard lead time applies.

 **Non-stock items** (shaded) please contact Flexco for dispatch options and lead times.



# Product Ordering Information

## H-Type® with V-Tips Segmented Blade Primary Cleaner

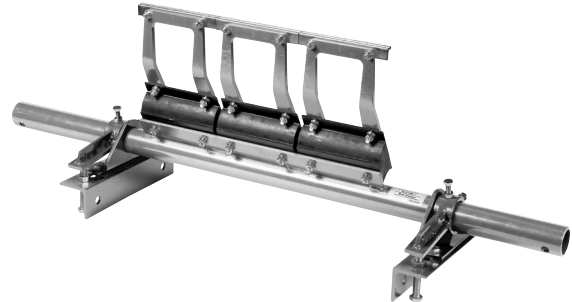
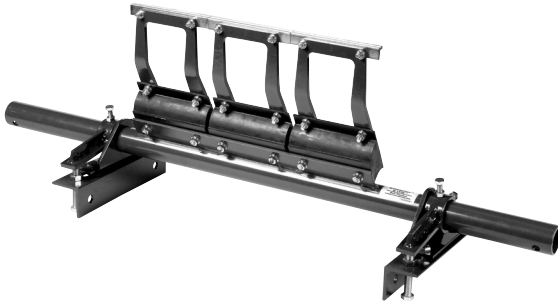

### H-Type® with V-Tips\*-Powder Coated

BELT WIDTH mm	SUSPENSION ARM SIZE	ORDERING NUMBER	ITEM CODE	WT. KG
450	SS	HV450SS	73026	30.0
450	S	HV450S	73028	30.0
450	M	HV450M	73019	30.0
600	SS	HV600SS	73045	35.0
600	S	HV600S	73030	35.0
600	M	HV600M	73173	35.0
750	SS	HV750SS	73053	37.0
750	S	HV750S	73032	37.0
750	M	HV750M	73174	37.0
900	SS	HV900SS	73055	42.0
900	S	HV900S	73034	42.0
900	M	HV900M	73175	42.0
900	L	HV900L	73178	42.0
1050	SS	HV1050SS	73057	46.0
1050	S	HV1050S	73056	46.0
1050	M	HV1050M	73036	46.0
1050	L	HV1050L	73179	46.0
1200	SS	HV1200SS	73059	50.0
1200	S	HV1200S	73058	50.0
1200	M	HV1200M	73038	50.0
1200	L	HV1200L	73180	50.0
1500	M	HV1500M	73177	64.0
1500	L	HV1500L	73158	64.0
1500	LL	HV1500LL	73215	64.0
1600	M	HV1600M	73637	68.0
1600	L	HV1600L	73638	68.0
1600	LL	HV1600LL	73639	68.0
1800	M	HVHD1800M	74602	95.0
1800	L	HVHD1800L	74477	95.0
1800	LL	HVHD1800LL	74478	95.0
2100	M	HVHD2100M	74539	102.0
2100	L	HVHD2100L	74540	102.0
2100	LL	HVHD2100LL	74541	102.0
2400	M	HVHD2400M	74544	118.0
2400	L	HVHD2400L	74545	118.0
2400	LL	HVHD2400LL	74546	118.0

Specify arm size when ordering.

### H-Type® with V-Tips\*-Stainless Steel

BELT WIDTH mm	SUSPENSION ARM SIZE	ORDERING NUMBER	ITEM CODE	WT. KG
450	SS	HV450SS-S/S	75293	30.0
450	S	HV450S-S/S	75294	30.0
450	M	HV450M-S/S	75295	30.0
600	SS	HV600SS-S/S	75296	36.0
600	S	HV600S-S/S	75297	36.0
600	M	HV600M-S/S	75298	36.0
750	SS	HV750SS-S/S	75299	38.0
750	S	HV750S-S/S	75300	38.0
750	M	HV750M-S/S	75301	38.0
900	SS	HV900SS-S/S	75302	43.0
900	S	HV900S-S/S	75303	43.0
900	M	HV900M-S/S	75304	43.0
900	L	HV900L-S/S	75305	43.0
1050	SS	HV1050SS-S/S	75306	47.0
1050	S	HV1050S-S/S	75307	47.0
1050	M	HV1050M-S/S	75308	47.0
1050	L	HV1050L-S/S	75309	47.0
1200	SS	HV1200SS-S/S	75310	50.0
1200	S	HV1200S-S/S	75311	50.0
1200	M	HV1200M-S/S	75312	50.0
1200	L	HV1200L-S/S	75313	50.0
1500	M	HV1500M-S/S	75314	64.0
1500	L	HV1500L-S/S	75315	64.0
1500	LL	HV1500LL-S/S	75316	64.0
1600	M	HV1600M-S/S	75317	68.0
1600	L	HV1600L-S/S	75318	68.0
1600	LL	HV1600LL-S/S	75319	68.0
1800	M	HVHD1800M-S/S	A1594	98.0
1800	L	HVHD1800L-S/S	A1595	98.0
1800	LL	HVHD1800LL-S/S	A1596	98.0
2100	M	HVHD2100M-S/S	A1597	104.0
2100	L	HVHD2100L-S/S	A1598	104.0
2100	LL	HVHD2100LL-S/S	A1599	104.0
2400	M	HVHD2400M-S/S	A1600	121.0
2400	L	HVHD2400L-S/S	A1601	121.0
2400	LL	HVHD2400LL-S/S	A1602	121.0

Specify arm size when ordering.

Stock items (non-shaded) refer to (\*) for specific lead time, if not specified, standard lead time applies.  
Non-stock items (shaded) please contact Flexco for dispatch options and lead times.

# Product Ordering Information

## H-Type® with V-Tips and PCSTensioner Segmented Blade Primary Cleaner

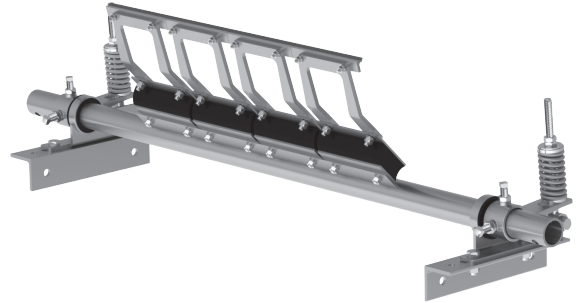
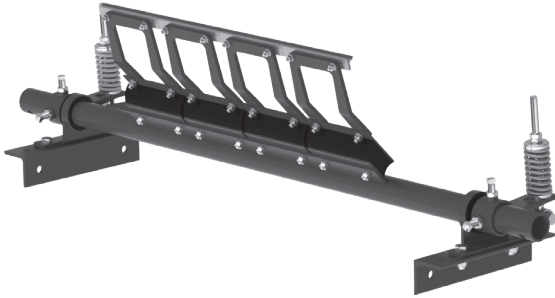

### H-Type® with V-Tips\*-Powder Coated

BELT WIDTH	SUSPENSION ARM SIZE	ORDERING NUMBER	ITEM CODE	WT. KG
mm				
450	SS	HV450SS-PCST	63936	36.8
450	S	HV450S-PCST	63937	36.8
450	M	HV450M-PCST	63938	36.8
600	SS	HV600SS-PCST	63939	41.8
600	S	HV600S-PCST	63940	41.8
600	M	HV600M-PCST	63941	41.8
750	SS	HV750SS-PCST	63942	43.8
750	S	HV750S-PCST	63943	43.8
750	M	HV750M-PCST	63944	43.8
900	SS	HV900SS-PCST	63945	48.8
900	S	HV900S-PCST	63946	48.8
900	M	HV900M-PCST	63947	48.8
900	L	HV900L-PCST	63948	48.8
1050	SS	HV1050SS-PCST	64045	52.8
1050	S	HV1050S-PCST	63950	52.8
1050	M	HV1050M-PCST	63951	52.8
1050	L	HV1050L-PCST	63952	52.8
1200	SS	HV1200SS-PCST	63953	56.8
1200	S	HV1200S-PCST	63954	56.8
1200	M	HV1200M-PCST	63955	56.8
1200	L	HV1200L-PCST	63956	56.8
1500	M	HV1500M-PCST	63957	70.8
1500	L	HV1500L-PCST	63958	70.8
1500	LL	HV1500LL-PCST	63959	70.8
1600	M	HV1600M-PCST	63960	74.8
1600	L	HV1600L-PCST	63961	74.8
1600	LL	HV1600LL-PCST	63962	74.8
1800	M	HV1800M-PCST	63963	101.8
1800	L	HV1800L-PCST	63964	101.8
1800	LL	HV1800LL-PCST	63965	101.8
2100	M	HV2100M-PCST	63966	108.8
2100	L	HV2100L-PCST	63967	108.8
2100	LL	HV2100LL-PCST	63968	108.8
2400	M	HV2400M-PCST	63969	125.0
2400	L	HV2400L-PCST	63970	125.0
2400	LL	HV2400LL-PCST	63971	125.0

### H-Type® with V-Tips\*-Stainless Steel

BELT WIDTH	SUSPENSION ARM SIZE	ORDERING NUMBER	ITEM CODE	WT. KG
mm				
450	SS	HV450SS-PCST-S/S	63978	37.3
450	S	HV450S-PCST-S/S	63979	
450	M	HV450M-PCST-S/S	63980	
600	SS	HV600SS-PCST-S/S	63981	43.3
600	S	HV600S-PCST-S/S	63982	
600	M	HV600M-PCST-S/S	63983	
750	SS	HV750SS-PCST-S/S	63984	45.3
750	S	HV750S-PCST-S/S	63985	
750	M	HV750M-PCST-S/S	63986	
900	SS	HV900SS-PCST-S/S	63987	50.3
900	S	HV900S-PCST-S/S	63988	
900	M	HV900M-PCST-S/S	63989	
900	L	HV900L-PCST-S/S	63990	54.3
1050	SS	HV1050SS-PCST-S/S	63991	
1050	S	HV1050S-PCST-S/S	63992	
1050	M	HV1050M-PCST-S/S	63993	57.3
1050	L	HV1050L-PCST-S/S	63994	
1200	SS	HV1200SS-PCST-S/S	63995	
1200	S	HV1200S-PCST-S/S	63996	71.3
1200	M	HV1200M-PCST-S/S	63997	
1200	L	HV1200L-PCST-S/S	63998	
1500	M	HV1500M-PCST-S/S	63999	75.3
1500	L	HV1500L-PCST-S/S	64000	
1500	LL	HV1500LL-PCST-S/S	64001	
1600	M	HV1600M-PCST-S/S	64002	105.3
1600	L	HV1600L-PCST-S/S	64003	
1600	LL	HV1600LL-PCST-S/S	64004	
1800	M	HVHD1800M-PCST-S/S	64005	111.3
1800	L	HVHD1800L-PCST-S/S	64006	
1800	LL	HVHD1800LL-PCST-S/S	64007	
2100	M	HVHD2100M-PCST-S/S	64008	128.4
2100	L	HVHD2100L-PCST-S/S	64009	
2100	LL	HVHD2100LL-PCST-S/S	64010	
2400	M	HVHD2400M-PCST-S/S	64011	128.4
2400	L	HVHD2400L-PCST-S/S	64012	
2400	LL	HVHD2400LL-PCST-S/S	64013	

Stock items (non-shaded) refer to (\*) for specific lead time, if not specified, standard lead time applies.  
 Non-stock items (shaded) please contact Flexco for dispatch options and lead times.

# Product Ordering Information

## Tips and Suspension Arms

### H-Type with XF8-FRAS, XF8 Non-FRAS and XF2-Non-FRAS Tips

#### Replacement XF8-Non-FRAS Tips

SIZE	ORDERING NUMBER	COLOUR	ITEM CODE	WT. KG
SS	HXF8SS	Purple	74307	1.5
S	HXF8S	Purple	74689	1.7
M	HXF8M	Purple	74690	1.8
L	HXF8L	Purple	74691	2.0

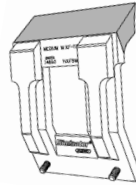

#### Tip Sizing

HEAD PULLEY DIAMETER + BELT & LAGGING	XF-TIP SIZE
mm	
up to 499	SS
500-799	S
800-999	M
1000-1200	L

Over 1200 mm- contact Flexco®.

#### Replacement XF8-FRAS Tips

SIZE	ORDERING NUMBER	COLOUR	ITEM CODE	WT. KG
SS	HXF8SS-Blue	Blue	77518	2.0
S	HXF8S-Blue	Blue	77519	2.0
M	HXF8M-Blue	Blue	77520	2.0
L	HXF8L-Blue	Blue	77521	2.5

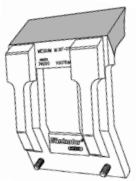

#### Tips Required Per Cleaner Size

BELT WIDTH	BLADE COVERAGE	NO. XF-TIPS REQUIRED
mm	mm	
450	400	2
600	600	3
750	600	3
900	800	4
1050	1000	5
1200	1200	6
1500	1400	7
1600	1600	8
1800	1800	9
2100	2000	10
2400	2400	12

#### Replacement XF2-Non-FRAS Tips

SIZE	ORDERING NUMBER	COLOUR	ITEM CODE	WT. KG
SS	HXF2-SS	Purple	75979	1.5
S	HXF2-S	Purple	75980	1.5
M	HXF2-M	Purple	75981	1.5
L	HXF2-L	Purple	75982	2.0

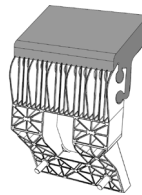

Specially formulated, long-wearing polyurethane blade tip. Impact-resistant, reinforced nylon base for rigidity and minimal deflection.

### H-Type with V-Tips

#### Replacement V-Tips

ORDERING NUMBER	ITEM CODE	WT. KG
HSA200	73489	0.5
HVT8-S/S	75419	0.5
HVPT-S/S	73631	1.2
HSA200-EL15	76027	0.7
HVT8-EL15-S/S	62254	1.4
HSA200-XL20	67775	0.9

#### Suspension Arm Size

HEAD PULLEY DIAMETER + BELT & LAGGING	SUSPENSION ARM SIZE
mm	
50-249	SSS
250-499	SS
500-799	S
800-999	M
1000-1199	L
1200-1700	LL

Over 1700 mm—contact Flexco.

#### Tips Required Per Cleaner Size

BELT WIDTH	BLADE COVERAGE	NO. V-TIPS REQUIRED
mm	mm	
450	400	2
600	600	3
750	600	3
900	800	4
1050	1000	5
1200	1200	6
1500	1400	7
1600	1600	8
1800	1800	9
2100	2000	10
2400	2400	12

#### Stainless Steel Replacement Suspension Arms

SIZE	ORDERING NUMBER	ITEM CODE	WT. KG
SSS	HSA8SSS-S/S	79655	0.7
SS	HSA8SS-S/S	73771	0.9
S	HSA8S-S/S	73772	1.1
M	HSA8M-S/S	73773	1.3
L	HSA8L-S/S	73774	1.5
LL	HSA8LL-S/S	74033	1.7

#### Replacement Suspension Arms

SIZE	ORDERING NUMBER	ITEM CODE	WT. KG.
SSS	HSA8SSS	75565	0.7
SS	HSA8SS	73047	0.9
S	HSA8S	73048	1.1
M	HSA8M	73049	1.3
L	HSA8L	73063	1.5
LL	HSA8LL	73064	1.7

Stock items (non-shaded) refer to (\*) for specific lead time, if not specified, standard lead time applies.  
Non-stock items (shaded) please contact Flexco for dispatch options and lead times.

# Replacement Parts List

## H-Type with PCST Optional Tensioners

### ATV Replacement Parts

REF	DESCRIPTION	ORDERING NUMBER	ITEM CODE	WT. KG
1	Air Primary Mount Bracket Stainless Steel	AIR HDMRK S/S	62034	2.0
2a	Bearing Repair Kit 60mm	HBRK-S/S-60	75422	1.5
2b	Bearing Repair Kit 73mm	HBRK-S/S-73	76246	2.0
3a	Air Primary Adjust Arm 60mm	AIR HARK-S/S-60	62035	1.5
3b	Air Primary Adjust Arm 73mm	AIR HARK-S/S-73	64175	2.0
4	Air Bag Primary	AIR BAG P	62036	0.5
5	Hex Nut	HEX NUT	G1211	0.1
6	Air Line Adapter	ATV-NIP	62037	0.1
-	Primary Air Tension Kit 60mm (incl. 2 ea items 1, 2a, 3a, 4, 5 and 6)	HATDMK-S/S	63861	11.0
-	Primary Air Tension Kit 73mm (incl. 2 ea items 1, 2b, 3b, 4, 5 and 6)	HDATDMK-S/S	63862	14.0

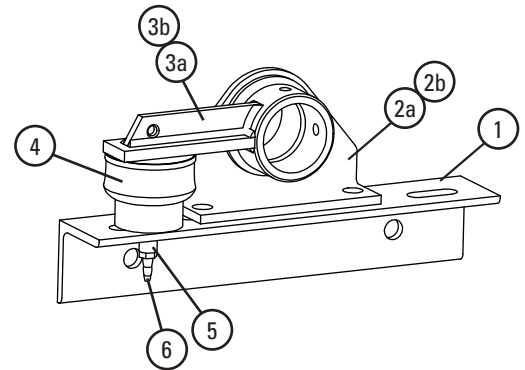

### P-CST Replacement Parts - Mild Steel PCST 60 mm

REF	DESCRIPTION	ORDERING NUMBER	ITEM CODE	WT. KG
1	H Bearing Bush 60mm	HCSBB-60	62513	0.1
2	Acme Pivot Rod Kit	ACME-PRK	62496	0.6
3	Acme Nut	ACME-N	62591	0.1
4a	Spring Black (To 1600 Belt Width Max)	STS-B	75844	0.5
4b	Spring Gold (To 2400 Belt Width Max)	STS-G	78142	0.5
5	Spring Bush Kit (Black/Gold)	HCSSB-B/G	62589	0.1
6	Torque Arm Kit 60mm	ESTAK-EST	76406	1.6
-	Black 60mm Compression Spring Side Assembly (to 1600 belt width max)	H60CSK-B	62747	11.0
-	Gold 60mm Compression Spring Side Assembly (to 2400 belt width max)	H60CSK-G	62741	11.0

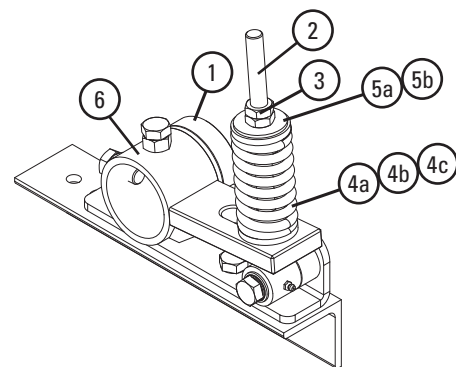

### P-CST Replacement Parts - Mild Steel PCST 73 mm

REF	DESCRIPTION	ORDERING NUMBER	ITEM CODE	WT. KG
1	H Bearing Bush 73mm	HCSBB-73	62514	2.0
2	Acme Pivot Rod Kit	ACME-PRK	62496	0.6
3	Acme Nut	ACME-N	62591	0.1
4a	Spring Black (To 1600 Belt Width Max)	STS-B	75844	0.5
4b	Spring Gold (To 2400 Belt Width Max)	STS-G	78142	0.5
4c	Spring Silver (Above 2400 Belt Width)	PSTS-S	75899	0.5
5a	Spring Bush (Black/Gold)	HCSSB-B/G	62589	0.1
5b	Spring Bush (Silver)	HCSSB-S	62590	0.2
6	Torque Arm Kit 73mm	HCSTAK	62494	1.6
-	Black 73mm Compression Spring Side Assembly (to 1600 belt width max)	H73CSK-B	62749	17.8
-	Gold 73mm Compression Spring Side Assembly (to 2400 belt width max)	H73CSK-G	62743	17.8
-	Silver 73mm Compression Spring Side Assembly (above 2400)	H73CSK-S	62745	18.0

### P-CST Replacement Parts - Stainless Steel PCST 73 mm

REF	DESCRIPTION	ORDERING NUMBER	ITEM CODE	WT. KG
1	H Bearing Bush 73mm	HCSBB-73	62514	2.0
2	Acme Pivot Rod Kit	ACME-PRK	62496	0.6
3	Acme Nut	ACME-N	62591	0.1
4a	Spring Black (To 1600 Belt Width Max)	STS-B-S/S	77632	0.5
4b	Spring Gold (To 2400 Belt Width Max)	STS-G-S/S	79057	0.5
4c	Spring Silver (Above 2400 Belt Width)	PSTS-S-S/S	79056	0.5
5a	Spring Bush (Black/Gold)	HCSSB-B/G	62589	0.1
5b	Spring Bush (Silver)	HCSSB-S	62590	0.2
6	Torque Arm Kit 73mm	HCSTAK-S/S	62495	1.6
-	Black 73mm Compression Spring Side Assembly (to 1600 belt width max)	H73CSK-B-S/S	62750	18.3
-	Gold 73mm Compression Spring Side Assembly (to 2400 belt width max)	H73CSK-G-S/S	62744	18.3
-	Silver 73mm Compression Spring Side Assembly (above 2400 belt width max)	H73CSK-S-S/S	62746	18.4

### P-CST Replacement Parts - Stainless Steel PCST 60 mm

REF	DESCRIPTION	ORDERING NUMBER	ITEM CODE	WT. KG
1	H Bearing Bush 60mm	HCSBB-60	62513	0.1
2	Acme Pivot Rod Kit	ACME-PRK	62496	0.6
3	Acme Nut	ACME-N	62591	0.1
4a	Spring Black (To 1600 Belt Width Max)	STS-B-S/S	77632	0.5
4b	Spring Gold (To 2400 Belt Width Max)	STS-G-S/S	79057	0.5
5	Spring Bush Kit (Black/Gold)	HCSSB-B/G	62589	0.1
6	Torque Arm Kit 60mm	ESTAK-EST-S/S	78849	1.6
-	Black 60mm Compression Spring Side Assembly (to 1600 belt width max)	H60CSK-B-S/S	62748	17.3
-	Gold 60mm Compression Spring Side Assembly (to 2400 belt width max)	H60CSK-G-S/S	62742	17.3

Stock items (non-shaded) refer to (\*) for specific lead time, if not specified, standard lead time applies.

Non-stock items (shaded) please contact Flexco for dispatch options and lead times.

# Replacement Parts List

## H-Type with Air/Water Optional Tensioners

### Air/Water Tensioner

ORDERING NUMBER	ITEM CODE	WT. KG
PAT1	65571	5.9



PAT1 (Single)

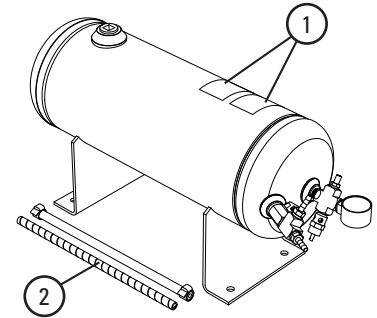

### Replacement Parts

REF	DESCRIPTION	ORDERING NUMBER	ITEM CODE	WT. KG
1	Tank Label Kit	PATLK	78791	0.05
2	Tank Hose Kit (incl. (1) ea. 10' hose & 1' poly spiral wrap, (2) hose clamp)	PATHK	78794	0.9

### Product Notes:

- For use with PAT cleaner assemblies and PAT control box.
- Single for applications with one cleaner, double for applications with two cleaners.
- 150# pop-off valve for safe pressurizing/charging of Air Tank.
- ASME Construction.

### H-Type Air Tensioner Settings

Belt Width	SS	S	M	L	LL
mm					
450	45	55	60	65	<b>80</b>
600	65	80	90	95	<b>120</b>
750	65	80	90	95	<b>120</b>
900	85	105	115	125	<b>155</b>
1050	105	130	145	155	<b>195</b>
1200	125	155	175	185	<b>235</b>
1500	145	180	200	220	<b>275</b>
1600	170	205	230	250	<b>310</b>
1800	185	225	255	275	<b>345</b>
2100	205	250	285	305	<b>385</b>
2400	245	300	340	365	<b>460</b>
2600	265	325	370	395	<b>500</b>
3000	305	370	425	455	<b>575</b>

### Air/Water Tensioner Replacement Parts

REF	DESCRIPTION	ORDERING NUMBER	ITEM CODE	WT. KG
1	Air/Water Bag (1 ea.)	AWTB	75905	1.7
2	Mounting Base (1 ea.)	AWTMB	75906	10.4
3	Torque Arm* (1 ea.)	AWTA	75907	5.3
4	Hose Kit (15 M of hose & (6) hose clamp)	AWTHK	75909	3.1
5	Control Box (Complete)	AWTCB	75908	0.5
-	AWT Tensioner (incl. (2) ea. items 12, 13, 14 & (1) ea. items 15 & 16)	AWT	75904	39.2
-	AWT Tensioner w/o Control Box (incl. (2) ea. items 12, 13, 14 & (1) ea. item 15)	AWTNCB	76069	34.2
-	AWT Tensioner w/o Control Box, 1 side (incl. (1) ea. items 12, 13, 14 & 15)	AWT-1S	76375	17.1

\*Hardware Included

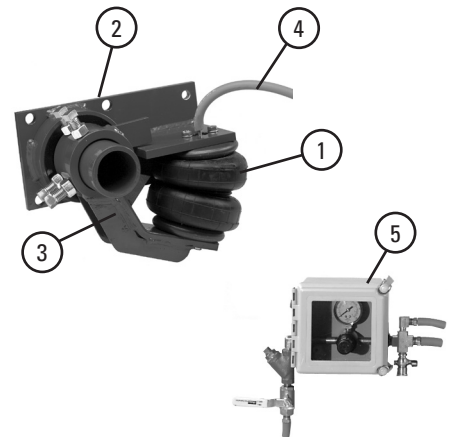

Stock items (non-shaded) refer to (\*) for specific lead time, if not specified, standard lead time applies.  
Non-stock items (shaded) please contact Flexco for dispatch options and lead times.

# Replacement Parts List

## H-Type® Segmented Blade Primary Cleaners

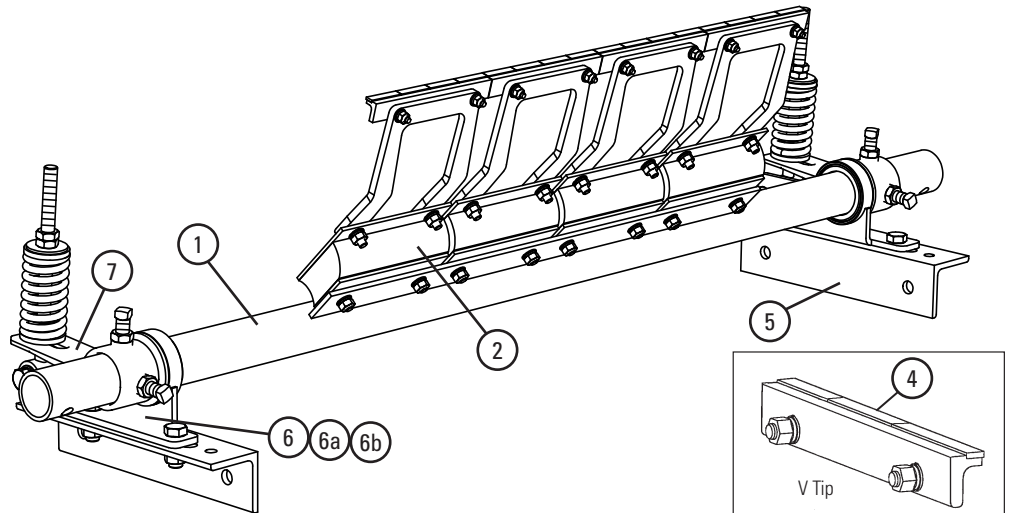
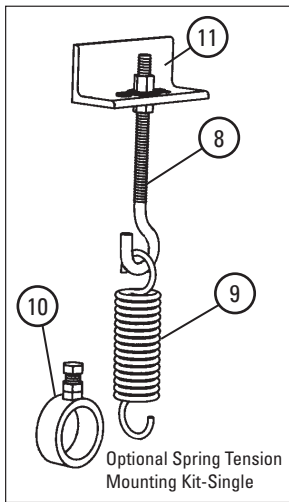

### Replacement Parts\*

REF	DESCRIPTION	BELT WIDTH mm	POLE LENGTH mm	POWDER COATED			STAINLESS STEEL	
				ORDERING NUMBER	ITEM CODE	WT. KG	ORDERING NUMBER	ITEM CODE
1	H-Type® Pole Standard-60mm Pole Diameter	450	1250	HP450	73027	10.0	HP450-S/S	75373
		600	1350	HP600	73029	11.0	HP600-S/S	75374
		750	1500	HP750	73031	13.0	HP750-S/S	75375
		900	1650	HP900	73033	15.0	HP900-S/S	75376
		1050	1800	HP1050	73035	20.0	HP1050-S/S	75377
	H-Type Pole Standard-73mm Pole Diameter	1200	1950	HP1200	73037	22.0	HP1200-S/S	75378
		1500	2350	HP1500	73066	24.0	HP1500-S/S	75379
		1600	2450	HP1600	73739	27.0	HP1600-S/S	75380
		1800	2650	HPHD1800	74601	34.0	HPHD1800-S/S	A2063
H-Type Pole Heavy-Duty-73mm Pole Diameter Braced and Gussetted	2000	2950	HPHD2000	74547	39.0	HPHD2000-S/S	A1783	
	2400	3250	HPHD2400	74548	43.5	HPHD2400-S/S	A2590	
2	Cushion			HSA	73486	2.0	HVC-S/S	73494
	Heavy-Duty Cushion			HSHD	73483	2.0	HSHD-S/S	76467
	H Polyshield (Not shown)			HPS8	73050	1.0	HSTSS	61173
4	V-Tip			HSA200	73489	0.5	HVT8-S/S	75419
							HVPT-S/S	73631
<b>SIDE MOUNTING ASSEMBLY COMPONENTS - TO SUIT 60 mm</b>								
5	H Mounting Bracket			HDMRK	74582	2.0	HDMRK-S/S	76245
6	H Bearing			HBRK	73068	1.5	HBRK-S/S	75422
6a	H Poly Bush 60mm			UNB60	61369	0.1		
6b	H Poly Bush 73mm			UNB73	A2671	0.1		
7	H Adjusting Arm			HARK	76406	1.5	HARK-S/S	75423
8	J-Bolt			STJK	74417	1.0		
9	Tension Spring			STTS	74419	1.0	STTS-S/S	75585
10	Spring Tensioner Collar			STCK	74506	1.0	STCK-S/S	75425
11	Spring Tensioner J-Bolt Mount			STJM	74775	1.0	STJM-S/S	75426
-	Spring Tension Kit-Dual (incl. 2 ea. 8, 9, 10 & 11)			STKD	74504	5.0	STKD-S/S	75427
-	H Mounting Kit- Dual (incl. 2 ea. 5, 6 & 7)			HMK	73054	11.0	HMK-S/S	75424
-	Black Compression Spring Side Assembly 60mm			HCSTK-60-B	62747	11.0	HCSTK-60-B-S/S	62748
-	Gold Compression Spring Side Assembly 60mm			HCSTK-60-G	62741	11.0	HCSTK-60-G-S/S	62742
<b>SIDE MOUNTING ASSEMBLY COMPONENTS - TO SUIT 73 mm</b>								
5	H Mounting Bracket			HDMRK	74582	3.0	HDMRK-S/S	76245
6	H Bearing Repair Kit			HBRKX	74549	2.0	HBRKX-S/S	76246
7	H Adjusting Arm			HDARK	74550	2.0	HDARK-S/S	76247
8	J-Bolt			STJK	74417	1.0		
9	Tension Spring			UTS	74420	1.0		
10	Spring Tensioner Collar			HDCK	74490	1.0	HDSTCK-S/S	A2189
11	Spring Tensioner J-Bolt Mount			STJM	74775	1.0	STJM-S/S	75426
-	Spring Tension Kit-Dual (incl. 2 ea. 8, 9, 10 & 11)			HDSTKD	A2518	5.0	HDSTKD-S/S	A2519
-	H Mounting Kit- Dual (incl. 2 ea. 5, 6 & 7)			HDMK	74551	14.0	HDMK-S/S	76248
-	Black Compression Spring Side Assembly (to 1600 belt width max)			H73CSK-B	62749	17.8	H73CSK-B-S/S	62750
-	Gold Compression Spring Side Assembly (to 2400 belt width max)			H73CSK-G	62743	17.8	H73CSK-G-S/S	62744



# Product Ordering Information

## H-Type ESAC (Mild Steel) HD Primary Cleaner with Enhanced Service Advantage Cartridge™

### Powder Coated H-Type® ESAC with V-Tips

TIP WIDTH mm	ARM SIZE	ORDERING NUMBER	ITEM CODE	WT KG
<b>Single Cartridge</b>				
600	CS	HV-600-SAC-CS	62515	74.2
	CM	HV-600-SAC-CM	62516	74.9
	CL	HV-600-SAC-CL	62517	75.3
800	CS	HV-800-SAC-CS	62518	86.5
	CM	HV-800-SAC-CM	62519	87.5
	CL	HV-800-SAC-CL	62520	88.1
1000	CS	HV-1000-SAC-CS	62521	94.9
	CM	HV-1000-SAC-CM	62522	96.2
	CL	HV-1000-SAC-CL	62523	96.9
1200	CS	HV-1200-SAC-CS	62524	103.3
	CM	HV-1200-SAC-CM	62525	104.7
	CL	HV-1200-SAC-CL	62526	105.6
1400	CS	HV-1400-SAC-CS	62527	115.9
	CM	HV-1400-SAC-CM	62528	117.5
	CL	HV-1400-SAC-CL	62529	118.6
1600	CM	HV-1600-SAC-CM	62530	130.0
	CL	HV-1600-SAC-CL	62531	131.3
	CLL	HV-1600-SAC-CLL	62532	135.2
1800	CM	HV-1800-SAC-CM	62533	137.2
	CL	HV-1800-SAC-CL	62534	138.5
	CLL	HV-1800-SAC-CLL	62535	142.8
<b>Dual Cartridge</b>				
1200	CS	HV-1200-2SAC-CS	62557	128.7
	CM	HV-1200-2SAC-CM	62558	130.3
	CL	HV-1200-2SAC-CL	62559	131.2
	CLL	HV-1200-2SAC-CLL	62560	134.1
1400	CS	HV-1400-2SAC-CS	62561	137.4
	CM	HV-1400-2SAC-CM	62562	139.0
	CL	HV-1400-2SAC-CL	62563	140.1
	CLL	HV-1400-2SAC-CLL	62564	143.4
1600	CM	HV-1600-2SAC-CM	62565	147.9
	CL	HV-1600-2SAC-CL	62566	149.1
	CLL	HV-1600-2SAC-CLL	62567	152.9
1800	CM	HV-1800-2SAC-CM	62568	159.5
	CL	HV-1800-2SAC-CL	62569	160.9
	CLL	HV-1800-2SAC-CLL	62570	163.8
2000	CM	HV-2000-2SAC-CM	62571	169.2
	CL	HV-2000-2SAC-CL	62572	170.7
	CLL	HV-2000-2SAC-CLL	62573	174.0
2200	CM	HV-2200-2SAC-CM	62574	182.4
	CL	HV-2200-2SAC-CL	62575	184.1
	CLL	HV-2200-2SAC-CLL	62576	187.7
2400	CM	HV-2400-2SAC-CM	62577	187.5
	CL	HV-2400-2SAC-CL	62578	189.3
	CLL	HV-2400-2SAC-CLL	62579	193.3

### H-Type ESAC Mild Steel Replacement Cartridge Kits with V-Tips

TIP WIDTH mm	ARM SIZE	ORDERING NUMBER	ITEM CODE	WT. KG
<b>Single Cartridge Kits</b>				
600	CS	H-CARK-600-CS	62536	23.2
	CM	H-CARK-600-CM	62537	24.0
	CL	H-CARK-600-CL	62538	24.5
800	CS	H-CARK-800-CS	62539	30.3
	CM	H-CARK-800-CM	62540	31.3
	CL	H-CARK-800-CL	62541	31.9
1000	CS	H-CARK-1000-CS	62542	36.1
	CM	H-CARK-1000-CM	62543	37.4
	CL	H-CARK-1000-CL	62544	38.2
1200	CS	H-CARK-1200-CS	62545	41.4
	CM	H-CARK-1200-CM	62546	43.3
	CL	H-CARK-1200-CL	62547	44.2
1400	CS	H-CARK-1400-CS	62548	49.0
	CM	H-CARK-1400-CM	62549	50.8
	CL	H-CARK-1400-CL	62550	51.9
1600	CM	H-CARK-1600-CS	62551	58.1
	CL	H-CARK-1600-CM	62552	59.3
	CLL	H-CARK-1600-CL	62553	63.1
1800	CM	H-CARK-1800-CS	62554	66.2
	CL	H-CARK-1800-CM	62555	67.6
	CLL	H-CARK-1800-CL	62556	71.9
<b>Dual Cartridge Kits</b>				
1200	CS	H-CARK2-1200-CS	62599	46.2
	CM	H-CARK2-1200-CM	62600	47.8
	CL	H-CARK2-1200-CL	62601	48.7
	CLL	H-CARK2-1200-CLL	62602	51.6
1400	CS	H-CARK2-1400-CS	62603	51.8
	CM	H-CARK2-1400-CM	62604	53.6
	CL	H-CARK2-1400-CL	62605	54.6
	CLL	H-CARK2-1400-CLL	62606	58.0
1600	CM	H-CARK2-1600-CM	62607	59.4
	CL	H-CARK2-1600-CL	62608	60.6
	CLL	H-CARK2-1600-CLL	62609	64.4
1800	CM	H-CARK2-1800-CM	62610	68.1
	CL	H-CARK2-1800-CL	62611	69.4
	CLL	H-CARK2-1800-CLL	62612	73.8
2000	CM	H-CARK2-2000-CM	62613	74.8
	CL	H-CARK2-2000-CL	62614	76.3
	CLL	H-CARK2-2000-CLL	62615	81.1
2200	CM	H-CARK2-2200-CM	62616	82.1
	CL	H-CARK2-2200-CL	62617	83.7
	CLL	H-CARK2-2200-CLL	62618	89.0
2400	CM	H-CARK2-2400-CM	62619	87.1
	CL	H-CARK2-2400-CL	62620	88.9
	CLL	H-CARK2-2400-CLL	62621	94.7

Stock items (non-shaded) refer to (\*) for specific lead time, if not specified, standard lead time applies.  
Non-stock items (shaded) please contact Flexco for dispatch options and lead times.



# Product Ordering Information

## H-Type ESAC (Stainless Steel) HD Primary Cleaner with Enhanced Service Advantage Cartridge™

### Stainless Steel H-Type® ESAC with V-Tips

TIP WIDTH	ARM SIZE	ORDERING NUMBER	ITEM CODE	WT. KG
mm				
<b>Single Cartridge</b>				
600	CS	HV-600-SAC-CS-S/S	62631	74.2
	CM	HV-600-SAC-CM-S/S	62632	74.9
	CL	HV-600-SAC-CL-S/S	62633	75.3
800	CS	HV-800-SAC-CS-S/S	62634	86.5
	CM	HV-800-SAC-CM-S/S	62635	87.5
	CL	HV-800-SAC-CL-S/S	62636	88.1
1000	CS	HV-1000-SAC-CS-S/S	62637	94.9
	CM	HV-1000-SAC-CM-S/S	62638	96.2
	CL	HV-1000-SAC-CL-S/S	62639	96.9
1200	CS	HV-1200-SAC-CS-S/S	62640	103.3
	CM	HV-1200-SAC-CM-S/S	62641	104.7
	CL	HV-1200-SAC-CL-S/S	62642	105.6
1400	CS	HV-1400-SAC-CS-S/S	62643	115.9
	CM	HV-1400-SAC-CM-S/S	62644	117.5
	CL	HV-1400-SAC-CL-S/S	62645	118.6
1600	CM	HV-1600-SAC-CM-S/S	62646	130.0
	CL	HV-1600-SAC-CL-S/S	62647	131.3
	CLL	HV-1600-SAC-CLL-S/S	62648	135.2
1800	CM	HV-1800-SAC-CM-S/S	62649	137.2
	CL	HV-1800-SAC-CL-S/S	62650	138.5
	CLL	HV-1800-SAC-CLL-S/S	62651	142.8
<b>Dual Cartridge</b>				
1200	CS	HV-1200-2SAC-CS-S/S	62673	128.7
	CM	HV-1200-2SAC-CM-S/S	62674	130.3
	CL	HV-1200-2SAC-CL-S/S	62675	131.2
	CLL	HV-1200-2SAC-CLL-S/S	62676	134.1
1400	CS	HV-1400-2SAC-CS-S/S	62677	137.4
	CM	HV-1400-2SAC-CM-S/S	62678	139.0
	CL	HV-1400-2SAC-CL-S/S	62679	140.1
	CLL	HV-1400-2SAC-CLL-S/S	62680	143.4
1600	CM	HV-1600-2SAC-CM-S/S	62681	147.9
	CL	HV-1600-2SAC-CL-S/S	62682	160.9
	CLL	HV-1600-2SAC-CLL-S/S	62683	152.9
1800	CM	HV-1800-2SAC-CM-S/S	62684	159.5
	CL	HV-1800-2SAC-CL-S/S	62685	160.9
	CLL	HV-1800-2SAC-CLL-S/S	62686	163.8
2000	CM	HV-2000-2SAC-CM-S/S	62687	169.2
	CL	HV-2000-2SAC-CL-S/S	62688	170.7
	CLL	HV-2000-2SAC-CLL-S/S	62689	174.0
2200	CM	HV-2200-2SAC-CM-S/S	62690	182.4
	CL	HV-2200-2SAC-CL-S/S	62691	184.1
	CLL	HV-2200-2SAC-CLL-S/S	62692	187.7
2400	CM	HV-2400-2SAC-CM-S/S	62693	187.5
	CL	HV-2400-2SAC-CL-S/S	62694	189.3
	CLL	HV-2400-2SAC-CLL-S/S	62695	193.3

### H-Type ESAC Stainless Steel Replacement Cartridge Kits with V-Tips

TIP WIDTH	ARM SIZE	ORDERING NUMBER	ITEM CODE	WT. KG
mm				
<b>Single Cartridge Kits</b>				
600	CS	H CARK-600-CS-S/S	62652	23.2
	CM	H CARK-600-CM-S/S	62653	24.0
	CL	H CARK-600-CL-S/S	62654	24.5
800	CS	H CARK-800-CS-S/S	62655	30.3
	CM	H CARK-800-CM-S/S	62656	31.3
	CL	H CARK-800-CL-S/S	62657	31.9
1000	CS	H CARK-1000-CS-S/S	62658	36.1
	CM	H CARK-1000-CM-S/S	62659	37.4
	CL	H CARK-1000-CL-S/S	62660	38.2
1200	CS	H CARK-1200-CS-S/S	62661	41.4
	CM	H CARK-1200-CM-S/S	62662	43.3
	CL	H CARK-1200-CL-S/S	62663	44.2
1400	CS	H CARK-1400-CS-S/S	62664	49.0
	CM	H CARK-1400-CM-S/S	62665	50.8
	CL	H CARK-1400-CL-S/S	62666	51.9
1600	CM	H CARK-1600-CS-S/S	62667	58.1
	CL	H CARK-1600-CM-S/S	62668	59.3
	CLL	H CARK-1600-CL-S/S	62669	63.1
1800	CM	H CARK-1800-CS-S/S	62670	66.2
	CL	H CARK-1800-CM-S/S	62671	67.6
	CLL	H CARK-1800-CL-S/S	62672	71.9
<b>Dual Cartridge Kits</b>				
1200	CS	H-CARK2-1200-CS-S/S	62705	46.2
	CM	H-CARK2-1200-CM-S/S	62706	47.8
	CL	H-CARK2-1200-CL-S/S	62707	48.7
	CLL	H-CARK2-1200-CLL-S/S	62708	51.6
1400	CS	H-CARK2-1400-CS-S/S	62709	51.8
	CM	H-CARK2-1400-CM-S/S	62710	53.6
	CL	H-CARK2-1400-CL-S/S	62711	54.6
	CLL	H-CARK2-1400-CLL-S/S	62712	58.0
1600	CM	H-CARK2-1600-CM-S/S	62713	59.4
	CL	H-CARK2-1600-CL-S/S	62714	60.6
	CLL	H-CARK2-1600-CLL-S/S	62715	64.4
	CM	H-CARK2-1800-CM-S/S	62716	68.1
1800	CL	H-CARK2-1800-CL-S/S	62717	69.4
	CLL	H-CARK2-1800-CLL-S/S	62718	73.8
	2000	CM	H-CARK2-2000-CM-S/S	62719
CL		H-CARK2-2000-CL-S/S	62720	76.3
CLL		H-CARK2-2000-CLL-S/S	62721	81.1
2200	CM	H-CARK2-2200-CM-S/S	62722	82.1
	CL	H-CARK2-2200-CL-S/S	62723	83.7
	CLL	H-CARK2-2200-CLL-S/S	62724	89.0
2400	CM	H-CARK2-2400-CM-S/S	62725	87.1
	CL	H-CARK2-2400-CL-S/S	62726	88.9
	CLL	H-CARK2-2400-CLL-S/S	62727	94.7

Stock items (non-shaded) refer to (\*) for specific lead time, if not specified, standard lead time applies.

Non-stock items (shaded) please contact Flexco for dispatch options and lead times.

### H-Type ESAC — Mild and Stainless Steel

#### Replacement V-Tips - Mild Steel

ORDERING NUMBER	ITEM CODE	WT. KG
HSA200	73489	0.5

#### Replacement Suspension Arms - Mild Steel

SIZE	ORDERING NUMBER	ITEM CODE	WT. KG
CS	HSA8-CS	62505	0.5
CM	HSA8-CM	62506	0.5
CL	HSA8-CL	62507	0.5
CLL	HSA8-CLL	62508	0.5

#### Replacement V-Tips - Stainless Steel

ORDERING NUMBER	ITEM CODE	WT. KG
HVT8-S/S	75419	0.9
HVPT-S/S	73631	1.2

#### Replacement Suspension Arms - Stainless Steel

SIZE	ORDERING NUMBER	ITEM CODE	WT. KG
CS	HSA8CS-S/S	62509	1.1
CM	HSA8CM-S/S	62510	1.3
CL	HSA8CL-S/S	62511	1.5
CLL	HSA8CLL-S/S	62512	1.7

#### Suspension Arm Size

HEAD PULLEY DIAMETER + BELT & LAGGING	SUSPENSION ARM SIZE
mm	
500-799	CS
800-999	CM
1000-1199	CL
1200-1700	CLL

Over 1700 mm - contact Flexco

#### Tips required per cleaner size

BELT WIDTH	BELT COVERAGE	NO. V-TIPS REQUIRED
mm	mm	
600	600	3
800	800	4
1000	1000	5
1200	1200	6
1400	1400	7
1600	1600	8
1800	1800	9
2000	2000	10
2200	2200	11
2400	2400	12

 Stock items (non-shaded) refer to (\*) for specific lead time, if not specified, standard lead time applies.

 Non-stock items (shaded) please contact Flexco for dispatch options and lead times.

# Replacement Parts List

## H-Type ESAC Single HD Primary Cleaner with Enhanced Service Advantage Cartridge™

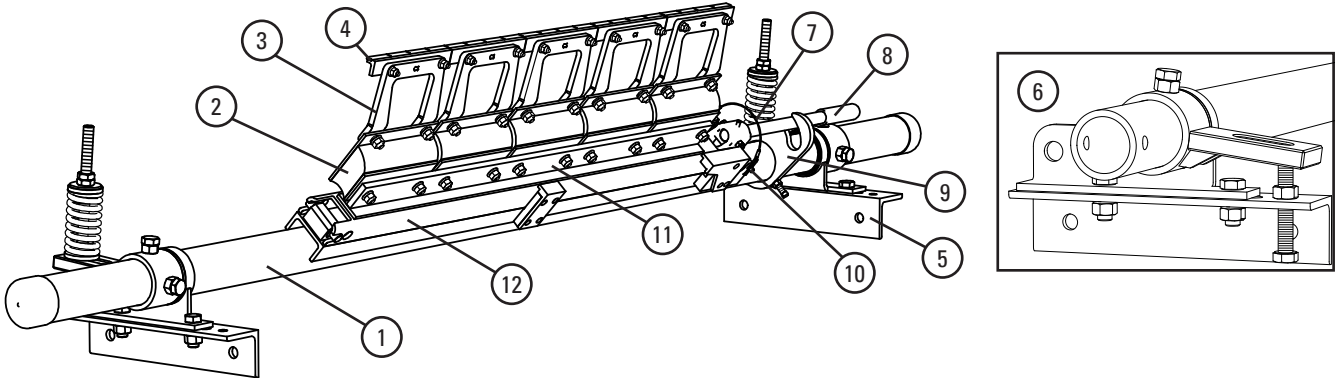

### REPLACEMENT PARTS

REF	DESCRIPTION	MILD STEEL			STAINLESS STEEL		
		ORDERING NUMBER	ITEM CODE	WT. KG	ORDERING NUMBER	ITEM CODE	WT. KG
1	H-Type Single ESAC Cartridge Pole	HCP-600	62751	30.5	HCP-600-S/S	62757	31.4
		HCP-800	62752	35.6	HCP-800-S/S	62758	36.7
		HCP-1000	62753	38.1	HCP-1000-S/S	62759	39.3
		HCP-1200	62754	40.7	HCP-1200-S/S	62760	42
		HCP-1400	62755	45.9	HCP-1400-S/S	62761	47.3
	HCP-1800	62756	51.0	HCP-1800-S/S	62762	52.6	
2	HD Cushion	HSHD	73483	2.0	HSHD-S/S	76467	2.0
3	Suspension Arm	HSA8CS	62505	0.9	HSA8CS-S/S	62509	1.0
		HSA8CM	62506	1.1	HSA8CM-S/S	62510	1.2
		HSA8CL	62507	1.3	HSA8CL-S/S	62511	1.3
		HSA8CLL	62508	1.8	HSA8CLL-S/S	62512	1.8
4	HV Tips	HSA200	73489	0.5	HVT8-S/S	75419	0.6
	HVPT Tips	-	-	-	HVPT-S/S	73631	0.6
5	Black Compression Spring Side Assembly (to 1600 belt width max)	H73CSK-B	62749	17.8	H73CSK-B-S/S	62750	18.3
	Gold Compression Spring Side Assembly (to 2400 belt width max)	H73CSK-G	62743	17.8	H73CSK-G-S/S	62744	18.3
6	Bolt Tension Side Assembly	H73BTK	74551	15.1	H73BTK-S/S	63080	15.6
7	SAC Removal Knuckle	SACRKN	77882	1.5			
8	SAC Removal Handle	SACRH	77883	1.4			
9	SAC Handle Lock Plate	SACRHL	77884	0.8			
10	Knuckle Retainer Pin	SACKRP	77885	0.1			

REF	DESCRIPTION	TIP WIDTH	ORDERING NUMBER	ITEM CODE	WT. KG
		mm			
11	H-Type Cartridge Adapter Plate	600	H-SAC-AP-600	62452	3.5
		800	H-SAC-AP-800	62453	4.8
		1000	H-SAC-AP-1000	62454	6.0
		1200	H-SAC-AP-1200	62455	7.3
		1400	H-SAC-AP-1400	62456	8.5
		1600	H-SAC-AP-1600	62457	9.8
12	SAC Replacement Single Cartridge	600	CART-24/600-S/S	78576	4.5
		800	CART-36/900-S/S	78578	6.7
		1000	CART-42/1050-S/S	78579	7.8
		1200	CART-48/1200-S/S	78580	8.9
		1400	CART-60/1500-S/S	78582	11.3
		1600	CART-72/1800-S/S	78583	13.5

#### HV/HVP Single SAC Black Spring Length Chart (for optimal blade tensioning)

Belt Width mm	CS	CM	CL	CLL
600	111	110	109	107
800	109	107	107	104
1000	106	105	104	100
1200	104	102	101	97
1400	102	100	98	93
1600	100	97	96	90
1800	97	95	93	-

#### HV/HVP Single SAC Gold Spring Length Chart (for optimal blade tensioning)

Belt Width mm	CS	CM	CL	CLL
600	113	113	112	111
800	112	111	111	109
1000	111	110	109	107
1200	109	108	107	105
1400	108	106	106	102
1600	106	105	104	100
1800	105	103	102	98

#### HV/HVP Dual SAC Gold Spring Length Chart (for optimal blade tensioning)

Belt Width mm	CS	CM	CL	CLL
1200	109	108	108	105
1400	108	107	106	103
1600	107	105	104	101
1800	105	104	103	99
2000	104	102	101	96
2200	103	101	99	94

#### HV/HVP Dual SAC Silver Spring Length Chart (for optimal blade tensioning)

Belt Width mm	CS	CM	CL	CLL
2200	159	158	157	154
2400	158	157	156	153
2600	157	156	155	151
2800	157	155	154	150
3000	156	154	153	149

Stock items (non-shaded) refer to (\*) for specific lead time, if not specified, standard lead time applies.  
Non-stock items (shaded) please contact Flexco for dispatch options and lead times.

# Replacement Parts List

## H-Type ESAC Dual HD Primary Cleaner with Enhanced Service Advantage Cartridge™

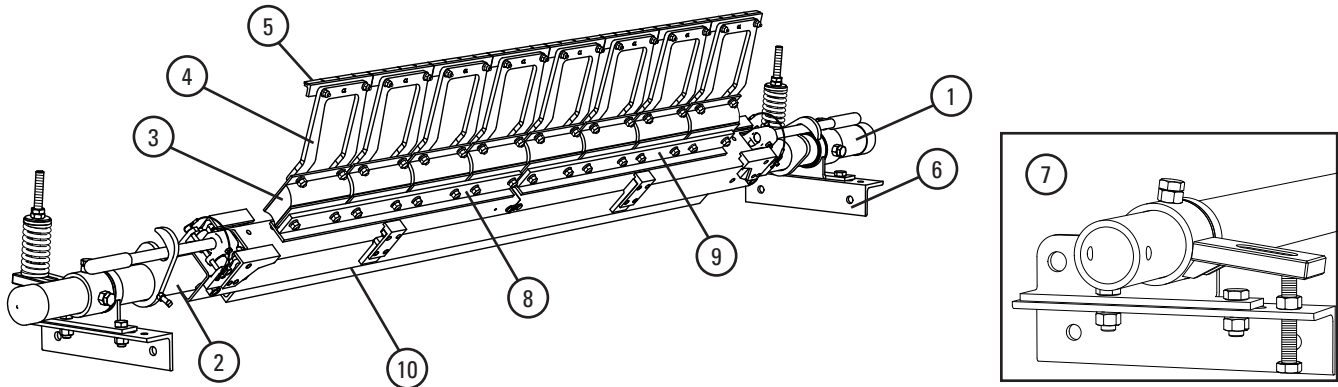

### Replacement Parts

REF	DESCRIPTION	MILD STEEL			STAINLESS STEEL			
		ORDERING NUMBER	ITEM CODE	WT. KG	ORDERING NUMBER	ITEM CODE	WT. KG	
1	H-Type Dual ESAC Centre Pole	H2CP-1200	62763	39.7	H2CP-1200-S/S	62801	39.7	
		H2CP-1400	62764	42.6	H2CP-1400-S/S	62802	42.6	
		H2CP-1600	62765	45.7	H2CP-1600-S/S	62803	45.7	
		H2CP-1800	62766	48.6	H2CP-1800-S/S	62804	48.6	
		H2CP-2000	62767	51.6	H2CP-2000-S/S	62805	51.6	
	H2CP-2400	62768	57.6	H2CP-2400-S/S	62806	57.6		
2	Extender Pole	MHP-EP	76392	24.5	MHP-EP-S/S	77599	24.5	
3	HD Cushion	HSHD	73483	2.0	HSHD-S/S	76467	2.0	
4	Suspension Arm	HSA8CS	62505	0.9	HSA8CS-S/S	62509	1.0	
		HSA8CM	62506	1.1	HSA8CM-S/S	62510	1.2	
		HSA8CL	62507	1.3	HSA8CL-S/S	62511	1.3	
		HSA8CLL	62508	1.8	HSA8CLL-S/S	62512	1.8	
5	HV Tips	HSA200	73489	0.5	HVT8-S/S	75419	0.6	
	HVPT Tips	-	-	-	HVPT-S/S	73631	0.6	
6	Black Compression Spring Side Assembly (1600mm belt width max)	H73CSK-B	62749	17.8	H73CSK-B-S/S	62750	18.3	
	Gold Compression Spring Side Assembly (2400mm belt width max)	H73CSK-G	62743	17.8	H73CSK-G-S/S	62744	18.3	
	Silver 150mm Compression Spring Side Assembly (above 2400mm belt width)	H73CSK-S	62745	18.0	H73CSK-S-S/S	62746	18.4	
7	Bolt Tension Side Assembly	H73BTK	74551	15.1	H73BTK-S/S	63080	15.6	
REF	DESCRIPTION	TIP WIDTH	ITEM 8 / LEFT HAND			ITEM 9 / RIGHT HAND		
		mm						
8 & 9	H-Type Cartridge Adapter Plate	1200	H-SAC-AP-600	62452	3.5	H-SAC-AP-600	62452	3.5
		1400	H-SAC-AP-800	62453	4.8	H-SAC-AP-600	62452	3.5
		1600	H-SAC-AP-800	62453	4.8	H-SAC-AP-800	62453	4.8
		1800	H-SAC-AP-1000	62454	6	H-SAC-AP-800	62453	4.8
		2000	H-SAC-AP-1000	62454	6	H-SAC-AP-1000	62454	6
		2200	H-SAC-AP-1200	62455	7.3	H-SAC-AP-1000	62454	6
10	SAC Replacement Dual Cartridge	2400	H-SAC-AP-1200	62455	7.3	H-SAC-AP-1200	62455	7.3
		1200	CART2-60/1500-S/S	78584	11.2			
		1400	CART2-66/1650-S/S	78634	12.3			
		1600	CART2-72/1800-S/S	78585	13.4			
		1800	CART2-78/1950-S/S	78635	14.5			
		2000	CART2-84/2100-S/S	78586	15.6			
		2200						
2400	CART2-96/2400-S/S	78587	17.8					

# Product Ordering Information

## H-Type ESAC with Extra Life V-Tips (Mild Steel) HD Primary Cleaner with Enhanced Service Advantage Cartridge™

### Powder Coated H-Type® ESAC with Extra Life V-Tips

TIP WIDTH mm	ARM SIZE	ORDERING NUMBER	ITEM CODE	WT KG
<b>Single Cartridge</b>				
600	CS	HV-600-SAC-CS-EL15	63206	74.2
	CM	HV-600-SAC-CM-EL15	63207	74.9
	CL	HV-600-SAC-CL-EL15	63208	75.3
800	CS	HV-800-SAC-CS-EL15	63209	86.5
	CM	HV-800-SAC-CM-EL15	63210	87.5
	CL	HV-800-SAC-CL-EL15	63211	88.1
1000	CS	HV-1000-SAC-CS-EL15	63212	94.9
	CM	HV-1000-SAC-CM-EL15	63213	96.2
	CL	HV-1000-SAC-CL-EL15	63214	96.9
1200	CS	HV-1200-SAC-CS-EL15	63215	103.3
	CM	HV-1200-SAC-CM-EL15	63216	104.7
	CL	HV-1200-SAC-CL-EL15	63217	105.6
1400	CS	HV-1400-SAC-CS-EL15	63218	115.9
	CM	HV-1400-SAC-CM-EL15	63219	117.5
	CL	HV-1400-SAC-CL-EL15	63220	118.6
1600	CM	HV-1600-SAC-CM-EL15	63221	130.0
	CL	HV-1600-SAC-CL-EL15	63222	131.3
	CLL	HV-1600-SAC-CLL-EL15	63223	135.2
1800	CM	HV-1800-SAC-CM-EL15	63224	137.2
	CL	HV-1800-SAC-CL-EL15	63225	138.5
	CLL	HV-1800-SAC-CLL-EL15	63226	142.8
<b>Dual Cartridge</b>				
1200	CS	HV-1200-2SAC-CS-EL15	63421	128.7
	CM	HV-1200-2SAC-CM-EL15	63422	130.3
	CL	HV-1200-2SAC-CL-EL15	63423	131.2
	CLL	HV-1200-2SAC-CLL-EL15	63424	134.1
1400	CS	HV-1400-2SAC-CS-EL15	63425	137.4
	CM	HV-1400-2SAC-CM-EL15	63426	139.0
	CL	HV-1400-2SAC-CL-EL15	63427	140.1
	CLL	HV-1400-2SAC-CLL-EL15	63428	143.4
1600	CM	HV-1600-2SAC-CM-EL15	63429	147.9
	CL	HV-1600-2SAC-CL-EL15	63430	149.1
	CLL	HV-1600-2SAC-CLL-EL15	63431	152.9
1800	CM	HV-1800-2SAC-CM-EL15	63432	159.5
	CL	HV-1800-2SAC-CL-EL15	63433	160.9
	CLL	HV-1800-2SAC-CLL-EL15	63434	163.8
2000	CM	HV-2000-2SAC-CM-EL15	63435	169.2
	CL	HV-2000-2SAC-CL-EL15	63436	170.7
	CLL	HV-2000-2SAC-CLL-EL15	63437	174.0
2200	CM	HV-2200-2SAC-CM-EL15	63438	182.4
	CL	HV-2200-2SAC-CL-EL15	63439	184.1
	CLL	HV-2200-2SAC-CLL-EL15	63440	187.7
2400	CM	HV-2400-2SAC-CM-EL15	63441	187.5
	CL	HV-2400-2SAC-CL-EL15	63442	189.3
	CLL	HV-2400-2SAC-CLL-EL15	63443	193.3

### H-Type ESAC Mild Steel Replacement Cartridge Kits with Extra Life V-Tips

TIP WIDTH mm	ARM SIZE	ORDERING NUMBER	ITEM CODE	WT KG
<b>Single Cartridge Kits</b>				
600	CS	H-CARK-600-CS-EL15	63631	23.2
	CM	H-CARK-600-CM-EL15	63632	24.0
	CL	H-CARK-600-CL-EL15	63633	24.5
800	CS	H-CARK-800-CS-EL15	63634	30.3
	CM	H-CARK-800-CM-EL15	63635	31.3
	CL	H-CARK-800-CL-EL15	63636	31.9
1000	CS	H-CARK-1000-CS-EL15	63637	36.1
	CM	H-CARK-1000-CM-EL15	63638	37.4
	CL	H-CARK-1000-CL-EL15	63639	38.2
1200	CS	H-CARK-1200-CS-EL15	63640	41.4
	CM	H-CARK-1200-CM-EL15	63641	43.3
	CL	H-CARK-1200-CL-EL15	63642	44.2
1400	CS	H-CARK-1400-CS-EL15	63643	49.0
	CM	H-CARK-1400-CM-EL15	63644	50.8
	CL	H-CARK-1400-CL-EL15	63645	51.9
1600	CM	H-CARK-1600-CS-EL15	63646	58.1
	CL	H-CARK-1600-CM-EL15	63647	59.3
	CLL	H-CARK-1600-CL-EL15	63648	63.1
1800	CM	H-CARK-1800-CS-EL15	63649	66.2
	CL	H-CARK-1800-CM-EL15	63650	67.6
	CLL	H-CARK-1800-CL-EL15	63651	71.9
<b>Dual Cartridge Kits</b>				
1200	CS	H-CARK2-1200-CS-EL15	63567	46.2
	CM	H-CARK2-1200-CM-EL15	63568	47.8
	CL	H-CARK2-1200-CL-EL15	63569	48.7
	CLL	H-CARK2-1200-CLL-EL15	63570	51.6
1400	CS	H-CARK2-1400-CS-EL15	63571	51.8
	CM	H-CARK2-1400-CM-EL15	63572	53.6
	CL	H-CARK2-1400-CL-EL15	63573	54.6
	CLL	H-CARK2-1400-CLL-EL15	63574	58.0
1600	CM	H-CARK2-1600-CM-EL15	63575	59.4
	CL	H-CARK2-1600-CL-EL15	63576	60.6
	CLL	H-CARK2-1600-CLL-EL15	63577	64.4
1800	CM	H-CARK2-1800-CM-EL15	63578	68.1
	CL	H-CARK2-1800-CL-EL15	63579	69.4
	CLL	H-CARK2-1800-CLL-EL15	63580	73.8
2000	CM	H-CARK2-2000-CM-EL15	63581	74.8
	CL	H-CARK2-2000-CL-EL15	63582	76.3
	CLL	H-CARK2-2000-CLL-EL15	63583	81.1
2200	CM	H-CARK2-2200-CM-EL15	63584	82.1
	CL	H-CARK2-2200-CL-EL15	63585	83.7
	CLL	H-CARK2-2200-CLL-EL15	63586	89.0
2400	CM	H-CARK2-2400-CM-EL15	63587	87.1
	CL	H-CARK2-2400-CL-EL15	63588	88.9
	CLL	H-CARK2-2400-CLL-EL15	63589	94.7

Stock items (non-shaded) refer to (\*) for specific lead time, if not specified, standard lead time applies.  
Non-stock items (shaded) please contact Flexco for dispatch options and lead times.

# Product Ordering Information

# H-Type ESAC with Extra Life V-Tips (Stainless Steel) HD Primary Cleaner with Enhanced Service Advantage Cartridge™

## Stainless Steel H-Type® ESAC with Extra Life V-Tips

TIP WIDTH mm	ARM SIZE	ORDERING NUMBER	ITEM CODE	WT KG
<b>Single Cartridge</b>				
600	CS	HV-600-SAC-CS-S/S-EL15	63227	74.2
	CM	HV-600-SAC-CM-S/S-EL15	63228	74.9
	CL	HV-600-SAC-CL-S/S-EL15	63229	75.3
800	CS	HV-800-SAC-CS-S/S-EL15	63230	86.5
	CM	HV-800-SAC-CM-S/S-EL15	63231	87.5
	CL	HV-800-SAC-CL-S/S-EL15	63232	88.1
1000	CS	HV-1000-SAC-CS-S/S-EL15	63233	94.9
	CM	HV-1000-SAC-CM-S/S-EL15	63234	96.2
	CL	HV-1000-SAC-CL-S/S-EL15	63235	96.9
1200	CS	HV-1200-SAC-CS-S/S-EL15	63236	103.3
	CM	HV-1200-SAC-CM-S/S-EL15	63237	104.7
	CL	HV-1200-SAC-CL-S/S-EL15	63238	105.6
1400	CS	HV-1400-SAC-CS-S/S-EL15	63239	115.9
	CM	HV-1400-SAC-CM-S/S-EL15	63240	117.5
	CL	HV-1400-SAC-CL-S/S-EL15	63241	118.6
1600	CM	HV-1600-SAC-CM-S/S-EL15	63242	130.0
	CL	HV-1600-SAC-CL-S/S-EL15	63243	131.3
	CLL	HV-1600-SAC-CLL-S/S-EL15	63244	135.2
1800	CM	HV-1800-SAC-CM-S/S-EL15	63245	137.2
	CL	HV-1800-SAC-CL-S/S-EL15	63246	138.5
	CLL	HV-1800-SAC-CLL-S/S-EL15	63247	142.8
<b>Dual Cartridge</b>				
1200	CS	HV-1200-2SAC-CS-S/S-EL15	63453	128.7
	CM	HV-1200-2SAC-CM-S/S-EL15	63454	130.3
	CL	HV-1200-2SAC-CL-S/S-EL15	63455	131.2
	CLL	HV-1200-2SAC-CLL-S/S-EL15	63456	134.1
1400	CS	HV-1400-2SAC-CS-S/S-EL15	63457	137.4
	CM	HV-1400-2SAC-CM-S/S-EL15	63458	139.0
	CL	HV-1400-2SAC-CL-S/S-EL15	63459	140.1
	CLL	HV-1400-2SAC-CLL-S/S-EL15	63460	143.4
1600	CM	HV-1600-2SAC-CM-S/S-EL15	63461	147.9
	CL	HV-1600-2SAC-CL-S/S-EL15	63462	149.1
	CLL	HV-1600-2SAC-CLL-S/S-EL15	63463	152.9
1800	CM	HV-1800-2SAC-CM-S/S-EL15	63464	159.5
	CL	HV-1800-2SAC-CL-S/S-EL15	63465	160.9
	CLL	HV-1800-2SAC-CLL-S/S-EL15	63466	163.8
2000	CM	HV-2000-2SAC-CM-S/S-EL15	63467	169.2
	CL	HV-2000-2SAC-CL-S/S-EL15	63468	170.7
	CLL	HV-2000-2SAC-CLL-S/S-EL15	63469	174.0
2200	CM	HV-2200-2SAC-CM-S/S-EL15	63470	182.4
	CL	HV-2200-2SAC-CL-S/S-EL15	63471	184.1
	CLL	HV-2200-2SAC-CLL-S/S-EL15	63472	187.7
2400	CM	HV-2400-2SAC-CM-S/S-EL15	63473	187.5
	CL	HV-2400-2SAC-CL-S/S-EL15	63474	189.3
	CLL	HV-2400-2SAC-CLL-S/S-EL15	63475	193.3

## H-Type ESAC Stainless Steel Replacement Cartridge Kits with Extra Life V-Tips

TIP WIDTH mm	ARM SIZE	ORDERING NUMBER	ITEM CODE	WT KG
<b>Single Cartridge Kits</b>				
600	CS	H CARK-600-CS-S/S-EL15	63652	23.2
	CM	H CARK-600-CM-S/S-EL15	63653	24
	CL	H CARK-600-CL-S/S-EL15	63654	24.5
800	CS	H CARK-800-CS-S/S-EL15	63655	30.3
	CM	H CARK-800-CM-S/S-EL15	63656	31.3
	CL	H CARK-800-CL-S/S-EL15	63657	31.9
1000	CS	H CARK-1000-CS-S/S-EL15	63658	36.1
	CM	H CARK-1000-CM-S/S-EL15	63659	37.4
	CL	H CARK-1000-CL-S/S-EL15	63660	38.2
1200	CS	H CARK-1200-CS-S/S-EL15	63661	41.4
	CM	H CARK-1200-CM-S/S-EL15	63662	43.3
	CL	H CARK-1200-CL-S/S-EL15	63663	44.2
1400	CS	H CARK-1400-CS-S/S-EL15	63664	49
	CM	H CARK-1400-CM-S/S-EL15	63665	50.8
	CL	H CARK-1400-CL-S/S-EL15	63666	51.9
1600	CM	H CARK-1600-CS-S/S-EL15	63667	58.1
	CL	H CARK-1600-CM-S/S-EL15	63668	59.3
	CLL	H CARK-1600-CL-S/S-EL15	63669	63.1
1800	CM	H CARK-1800-CS-S/S-EL15	63670	66.2
	CL	H CARK-1800-CM-S/S-EL15	63671	67.6
	CLL	H CARK-1800-CL-S/S-EL15	63672	71.9
<b>Dual Cartridge Kits</b>				
1200	CS	H-CARK2-1200-CS-S/S-EL15	63599	46.2
	CM	H-CARK2-1200-CM-S/S-EL15	63600	47.8
	CL	H-CARK2-1200-CL-S/S-EL15	63601	48.7
	CLL	H-CARK2-1200-CLL-S/S-EL15	63602	51.6
1400	CS	H-CARK2-1400-CS-S/S-EL15	63603	51.8
	CM	H-CARK2-1400-CM-S/S-EL15	63604	53.6
	CL	H-CARK2-1400-CL-S/S-EL15	63605	54.6
	CLL	H-CARK2-1400-CLL-S/S-EL15	63606	58
1600	CM	H-CARK2-1600-CM-S/S-EL15	63607	59.4
	CL	H-CARK2-1600-CL-S/S-EL15	63608	60.6
	CLL	H-CARK2-1600-CLL-S/S-EL15	63609	64.4
1800	CM	H-CARK2-1800-CM-S/S-EL15	63610	68.1
	CL	H-CARK2-1800-CL-S/S-EL15	63611	69.4
	CLL	H-CARK2-1800-CLL-S/S-EL15	63612	73.8
2000	CM	H-CARK2-2000-CM-S/S-EL15	63613	74.8
	CL	H-CARK2-2000-CL-S/S-EL15	63614	76.3
	CLL	H-CARK2-2000-CLL-S/S-EL15	63615	81.1
2200	CM	H-CARK2-2200-CM-S/S-EL15	63616	82.1
	CL	H-CARK2-2200-CL-S/S-EL15	63617	83.7
	CLL	H-CARK2-2200-CLL-S/S-EL15	63618	89
2400	CM	H-CARK2-2400-CM-S/S-EL15	63619	87.1
	CL	H-CARK2-2400-CL-S/S-EL15	63620	88.9
	CLL	H-CARK2-2400-CLL-S/S-EL15	63621	94.7

Stock items (non-shaded) refer to (\*) for specific lead time, if not specified, standard lead time applies.

Non-stock items (shaded) please contact Flexco for dispatch options and lead times.

# Product Ordering Information

## Tips and Suspension Arms

### H-Type ESAC with Extra Life V-Tips — Mild and Stainless Steel

#### Replacement V-Tips - Mild Steel

ORDERING NUMBER	ITEM CODE	WT. KG
HSA200	73489	0.5
HSA200-EL15	76027	0.6

#### Replacement Suspension Arms - Mild Steel

SIZE	ORDERING NUMBER	ITEM CODE	WT. KG
CS	HSA8CS	62505	1.1
CM	HSA8CM	62506	1.3
CL	HSA8CL	62507	1.5
CLL	HSA8CLL	62508	1.7

#### Replacement V-Tips - Stainless Steel

ORDERING NUMBER	ITEM CODE	WT. KG
HVT8-S/S	75419	0.9
HVPT-S/S	73631	1.2

#### Replacement Suspension Arms - Stainless Steel

SIZE	ORDERING NUMBER	ITEM CODE	WT. KG
CS	HSA8CS-S/S	62509	1.1
CM	HSA8CM-S/S	62510	1.3
CL	HSA8CL-S/S	62511	1.5
CLL	HSA8CLL-S/S	62512	1.7

#### Suspension Arm Size

HEAD PULLEY DIAMETER + BELT & LAGGING	SUSPENSION ARM SIZE
mm	
500-799	CS
800-999	CM
1000-1199	CL
1200-1700	CLL

Over 1700 mm - contact Flexco

#### Tips required per cleaner size

BELT WIDTH	BELT COVERAGE	NO. V-TIPS REQUIRED
mm	mm	
600	600	3
800	800	4
1000	1000	5
1200	1200	6
1400	1400	7
1600	1600	8
1800	1800	9
2000	2000	10
2200	2200	11
2400	2400	12

Stock items (non-shaded) refer to (\*) for specific lead time, if not specified, standard lead time applies.

Non-stock items (shaded) please contact Flexco for dispatch options and lead times.



# Replacement Parts List

## H-Type ESAC with Extra Life V-Tips Single HD Primary Cleaner with Enhanced Service Advantage Cartridge™

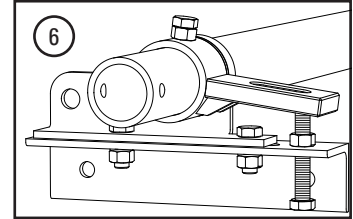
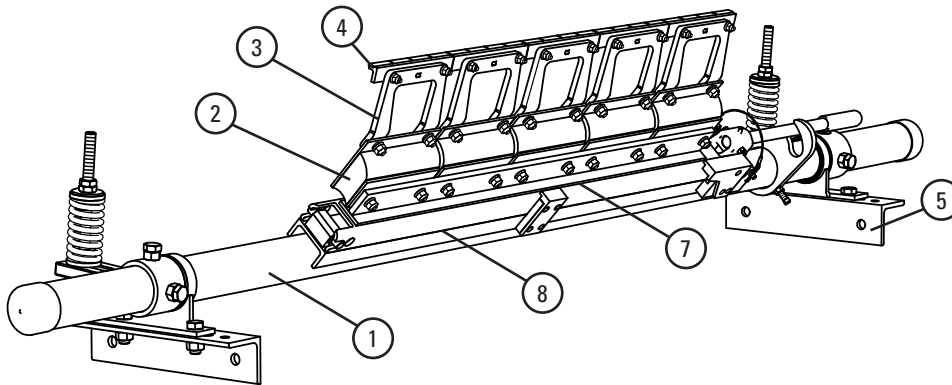

### REPLACEMENT PARTS

REF	DESCRIPTION	MILD STEEL			STAINLESS STEEL		
		ORDERING NUMBER	ITEM CODE	WT. KG	ORDERING NUMBER	ITEM CODE	WT. KG
1	H-Type Single ESAC Cartridge Pole	HCP-600	62751	30.5	HCP-600-S/S	62757	31.4
		HCP-800	62752	35.6	HCP-800-S/S	62758	36.7
		HCP-1000	62753	38.1	HCP-1000-S/S	62759	39.3
		HCP-1200	62754	40.7	HCP-1200-S/S	62760	42.0
		HCP-1400	62755	45.9	HCP-1400-S/S	62761	47.3
		HCP-1800	62756	51.0	HCP-1800-S/S	62762	52.6
2	HD Cushion	HSHD	73483	2.0	HSHD-S/S	76467	2.0
3	Suspension Arm	HSA8CS	62505	0.9	HSA8CS-S/S	62509	1.0
		HSA8CM	62506	1.1	HSA8CM-S/S	62510	1.2
		HSA8CL	62507	1.3	HSA8CL-S/S	62511	1.3
		HSA8CLL	62508	1.8	HSA8CLL-S/S	62512	1.8
4	HV Tips	HSA200	73489	0.5	HVT8-S/S	75419	0.6
	HV EL15 Tips	HSA200-EL15	76027	0.5	HVT8-EL15-S/S	62254	0.6
5	Black Compression Spring Side Assembly (to 1600 belt width max)	H73CSK-B	62749	17.8	H73CSK-B-S/S	62750	18.3
	Gold Compression Spring Side Assembly (to 2400 belt width max)	H73CSK-G	62743	17.8	H73CSK-G-S/S	62744	18.3
6	Bolt Tension Side Assembly	H73BTK	74551	15.1	H73BTK-S/S	63080	15.6
7	H-Type Cartridge Adapter Plate	<b>TIP WIDTH</b>					
		<b>mm</b>					
		600	H-SAC-AP-600	62452	3.5		
		800	H-SAC-AP-800	62453	4.8		
		1000	H-SAC-AP-1000	62454	6.0		
		1200	H-SAC-AP-1200	62455	7.3		
		1400	H-SAC-AP-1400	62456	8.5		
8	SAC Replacement Single Cartridge	600	CART-24/600-S/S	78576	4.5		
		800	CART-36/900-S/S	78578	6.7		
		1000	CART-42/1050-S/S	78579	7.8		
		1200	CART2-48/1200-S/S	78580	8.9		
		1400	CART-60/1500-S/S	78582	11.3		
		1600					
		1800	CART-72/1800-S/S	78583	13.5		

#### HV/HVP Single SAC Black Spring Length Chart (for optimal blade tensioning)

Belt Width mm	CS	CM	CL	CLL
600	111	110	109	107
800	109	107	107	104
1000	106	105	104	100
1200	104	102	101	97
1400	102	100	98	93
1600	100	97	96	90
1800	97	95	93	-

#### HV/HVP Single SAC Gold Spring Length Chart (for optimal blade tensioning)

Belt Width mm	CS	CM	CL	CLL
600	113	113	112	111
800	112	111	111	109
1000	111	110	109	107
1200	109	108	107	105
1400	108	106	106	102
1600	106	105	104	100
1800	105	103	102	98

#### HV/HVP Dual SAC Gold Spring Length Chart (for optimal blade tensioning)

Belt Width mm	CS	CM	CL	CLL
1200	109	108	108	105
1400	108	107	106	103
1600	107	105	104	101
1800	105	104	103	99
2000	104	102	101	96
2200	103	101	99	94

#### HV/HVP Dual SAC Silver Spring Length Chart (for optimal blade tensioning)

Belt Width mm	CS	CM	CL	CLL
2200	159	158	157	154
2400	158	157	156	153
2600	157	156	155	151
2800	157	155	154	150
3000	156	154	153	149

Stock items (non-shaded) refer to (\*) for specific lead time, if not specified, standard lead time applies.  
Non-stock items (shaded) please contact Flexco for dispatch options and lead times.

# Replacement Parts List

## H-Type ESAC with Extra Life V-Tips Dual HD Primary Cleaner with Enhanced Service Advantage Cartridge™

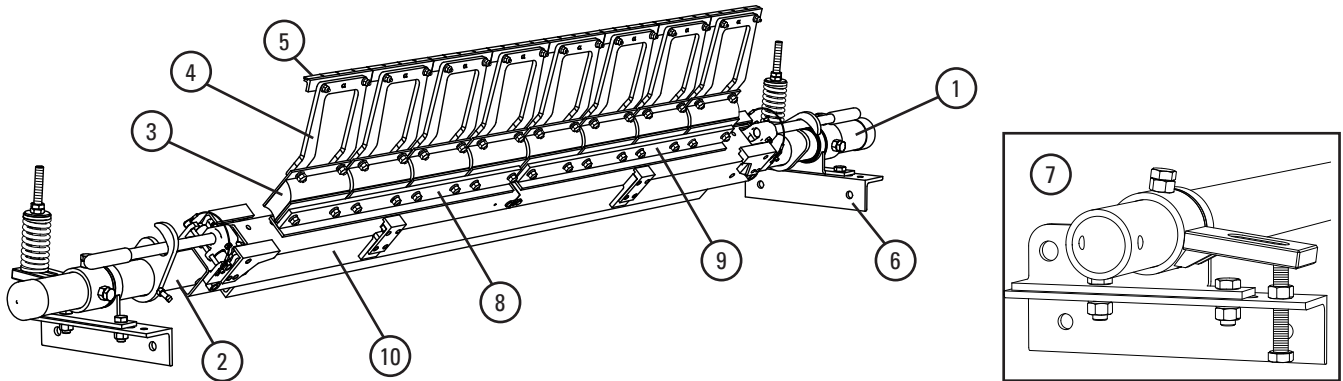

### Replacement Parts

REF	DESCRIPTION	MILD STEEL			STAINLESS STEEL			
		ORDERING NUMBER	ITEM CODE	WT. KG	ORDERING NUMBER	ITEM CODE	WT. KG	
1	H-Type Dual ESAC Centre Pole	H2CP-1200	62763	39.7	H2CP-1200-S/S	62801	39.7	
		H2CP-1400	62764	42.6	H2CP-1400-S/S	62802	42.6	
		H2CP-1600	62765	45.7	H2CP-1600-S/S	62803	45.7	
		H2CP-1800	62766	48.6	H2CP-1800-S/S	62804	48.6	
		H2CP-2000	62767	51.6	H2CP-2000-S/S	62805	51.6	
		H2CP-2400	62768	57.6	H2CP-2400-S/S	62806	57.6	
2	Extender Pole	MHP-EP	76392	24.5	MHP-EP-S/S	77599	24.5	
3	HD Cushion	HSHD	73483	2.0	HSHD-S/S	76467	2.0	
4	Suspension Arm	HSA8CS	62505	0.9	HSA8CS-S/S	62509	1.0	
		HSA8CM	62506	1.1	HSA8CM-S/S	62510	1.2	
		HSA8CL	62507	1.3	HSA8CL-S/S	62511	1.3	
		HSA8CLL	62508	1.8	HSA8CLL-S/S	62512	1.8	
5	HV Tips	HSA200	73489	0.5	HVT8-S/S	75419	0.6	
	HV EL15 Tips	HSA200-EL15	76027	0.5	HVT8-EL15-S/S	62254	0.6	
	HVPT Tips	-	-	-	HVPT-S/S	73631	0.6	
6	Black Compression Spring Side Assembly (1600mm belt width max)	H73CSK-B	62749	17.8	H73CSK-B-S/S	62750	18.3	
	Gold Compression Spring Side Assembly (2400mm belt width max)	H73CSK-G	62743	17.8	H73CSK-G-S/S	62744	18.3	
	Silver 150mm Compression Spring Side Assembly (above 2400mm belt width)	H73CSK-S	62745	18.0	H73CSK-S-S/S	62746	18.4	
7	Bolt Tension Side Assembly	H73BTK	74551	15.1	H73BTK-S/S	63080	15.6	
REF	DESCRIPTION	TIP WIDTH	ITEM 8 / LEFT HAND			ITEM 9 / RIGHT HAND		
		mm						
8 & 9	H-Type Cartridge Adapter Plate	1200	H-SAC-AP-600	62452	3.5	H-SAC-AP-600	62452	3.5
		1400	H-SAC-AP-800	62453	4.8	H-SAC-AP-600	62452	3.5
		1600	H-SAC-AP-800	62453	4.8	H-SAC-AP-800	62453	4.8
		1800	H-SAC-AP-1000	62454	6	H-SAC-AP-800	62453	4.8
		2000	H-SAC-AP-1000	62454	6	H-SAC-AP-1000	62454	6
		2200	H-SAC-AP-1200	62455	7.3	H-SAC-AP-1000	62454	6
		2400	H-SAC-AP-1200	62455	7.3	H-SAC-AP-1200	62455	7.3
10	SAC Replacement Dual Cartridge	1200	CART2-60/1500-S/S	78584	11.2			
		1400	CART2-66/1650-S/S	78634	12.3			
		1600	CART2-72/1800-S/S	78585	13.4			
		1800	CART2-78/1950-S/S	78635	14.5			
		2000	CART2-84/2100-S/S	78586	15.6			
		2200	CART2-96/2400-S/S	78587	17.8			

Stock items (non-shaded) refer to (\*) for specific lead time, if not specified, standard lead time applies.  
Non-stock items (shaded) please contact Flexco for dispatch options and lead times.

# Product Ordering Information

## Y-Type™ Standard Duty Secondary Cleaner with Carbide or Polyurethane Blades

### Y-Type™ Standard Duty with Purple Polyurethane Blades and YST Tension

BELT WIDTH	ORDERING NUMBER	ITEM CODE	WT. KG
mm			
450	YT-450S	83229	26.8
600	YT-600S	83230	29.5
750	YT-750S	83231	32.3
900	YT-900S	83232	35.0
1050	YT-1050S	83233	37.7
1200	YT-1200S	83234	40.5

Lead time: 2 weeks

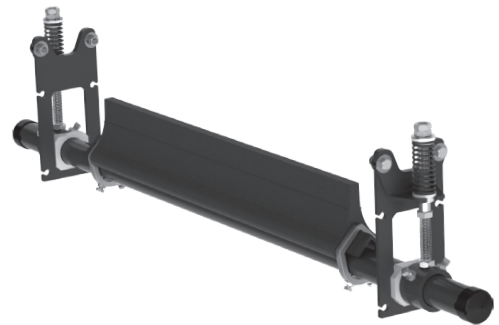

### Y-Type™ Standard Duty with Red UHT Polyurethane Blades and YST Tension

BELT WIDTH	ORDERING NUMBER	ITEM CODE	WT. KG
mm			
450	YTR-18S	91798	26.8
600	YTR-24S	91799	29.5
750	YTR-30S	91800	32.2
900	YTR-36S	91801	34.9
1050	YTR-42S	91802	37.6
1200	YTR-48S	91803	40.4

Lead time: 2 weeks

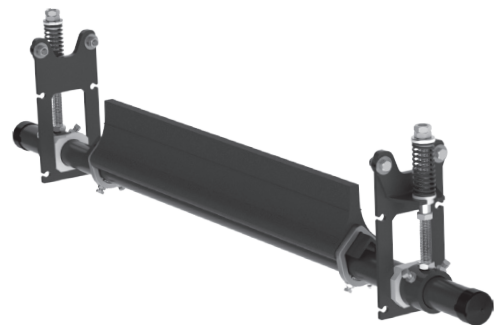

### Y-Type™ Standard Duty with Carbide Blades and Bolt Tension

BELT WIDTH	ORDERING NUMBER	ITEM CODE	WT. KG
mm			
450	YTC-450	83223	30.6
600	YTC-600	83224	33.3
750	YTC-750	83225	36.1
900	YTC-900	83226	38.8
1050	YTC-1050	83227	41.5
1200	YTC-1200	83228	44.3

Lead time: 2 weeks

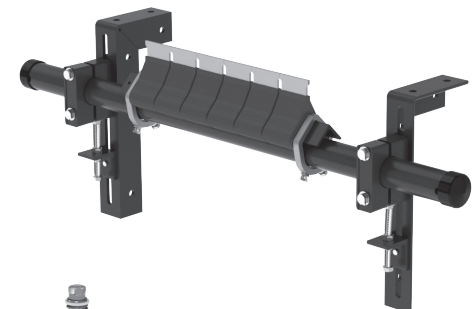

### Y-Type™ Standard Duty with Carbide Blades and YST Tension

BELT WIDTH	ORDERING NUMBER	ITEM CODE	WT. KG
mm			
450	YT-TC-450S	83241	25.0
600	YT-TC-600S	83242	27.3
750	YT-TC-750S	83243	29.5
900	YT-TC-900S	83244	31.8
1050	YT-TC-1050S	83245	34.5
1200	YT-TC-1200S	83246	37.3

Lead time: 2 weeks

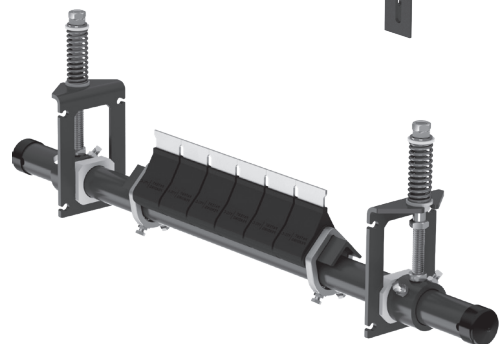

#### Product Notes:

- Works on reversing belts, vulcanized belts, and belts with mechanical fasteners.
- Visual Blade Tension Check: Measure the tension spring and refer to Spring Length Chart on mounting base for the correct length for best cleaning performance.
- Tensioner: Standard Duty YST Spring Tensioner for self-adjusting tensioning with easy retensioning adjustments. The tensioner can be mounted in pull-up or push-up position.
- Simple design makes changing blades fast and easy. Blades can be removed and replaced individually, or all at once with the cartridge.

# Product Ordering Information

## Y-Type™ Standard Duty Replacement Blades/Cartridges

### Replacement Blades/Cartridges - Standard Duty Carbide

BELT WIDTH	ORDERING NUMBER	ITEM CODE	WT. KG
mm			
-	YT-C*	79574	0.5
450	YCART-18/450-TC	79811	5.7
600	YCART-24/600-TC	79812	7.5
750	YCART-30/750-TC	79813	9.3
900	YCART-36/900-TC	79814	11.0
1050	YCART-42/1050-TC	79815	12.8
1200	YCART-48/1200-TC	79816	14.5

\*Single 75 mm blade segment  
Lead time: 2 weeks

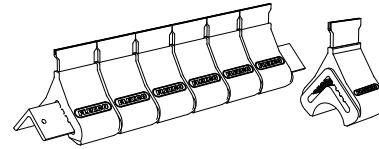

Y-Type™ Standard Duty Carbide Blade Cartridge

### Replacement Blades/Cartridges - Standard Duty Purple Polyurethane

BELT WIDTH	ORDERING NUMBER	ITEM CODE	WT. KG
mm			
-	YT-P*	79573	0.5
450	YCART-18/450-P	79617	6.0
600	YCART-24/600-P	79618	7.8
750	YCART-30/750-P	79619	9.6
900	YCART-36/900-P	79620	11.4
1050	YCART-42/1050-P	79621	13.2
1200	YCART-48/1200-P	79622	15.0

\*Single 75 mm blade segment  
Lead time: 2 weeks

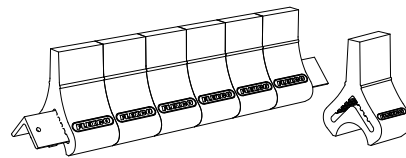

Y-Type™ Standard Duty Purple Polyurethane Blade Cartridge

### Replacement Blades/Cartridges - Standard Duty Red UHT Polyurethane

BELT WIDTH	ORDERING NUMBER	ITEM CODE	WT. KG
mm			
-	YT-R*	91804	0.5
450	YCART-18/450-R	91805	5.9
600	YCART-24/600-R	91806	7.7
750	YCART-30/750-R	91807	9.5
900	YCART-36/900-R	91808	11.3
1050	YCART-42/1050-R	91809	13.2
1200	YCART-48/1200-R	91810	15.0

\*Single 75 mm blade segment  
Lead time: 2 weeks

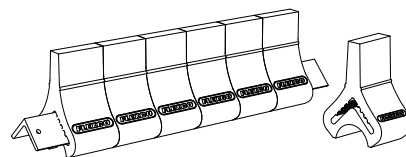

Y-Type™ Standard Duty Red UHT Polyurethane Blade Cartridge

Stock items (non-shaded) refer to (\*) for specific lead time, if not specified, standard lead time applies.  
Non-stock items (shaded) please contact Flexco for dispatch options and lead times.

# Specifications & Guidelines

## Y-Type™ Standard Duty Secondary Cleaner with Carbide or Polyurethane Blades

### Pole Length Specifications

Cleaner Size	Pole Length	Maximum Conveyor Span
mm	mm	mm
450	1200	1025
600	1350	1175
750	1500	1325
900	1650	1475
1050	1800	1625
1200	1950	1775

Pole Length - Belt +750 mm (30")  
Pole Diameter - 60 mm (2-3/8")

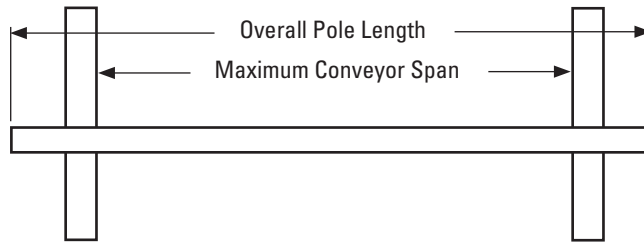

### Clearance Guidelines for Installation

Cleaner Type	Belt Width/ Cleaner Size	Horizontal Clearance Required	Vertical Clearance Required
	mm	mm	mm
Y-Type® Polyurethane	450-1200	110	210
Y-Type Carbide	450-1200	110	184

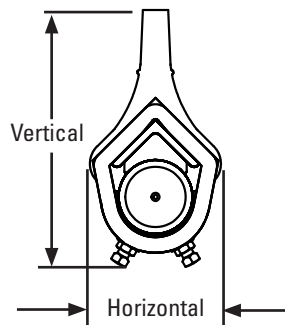

### Y-Type Blade Specifications

Cushion	Durometer	Temperature Range
Purple (Standard)	86A	-35 to 82° C
Red (Ultra High-Temp)	90A	Up to 200° C Spikes to 232° C
Carbide	86A	-35 to 82° C

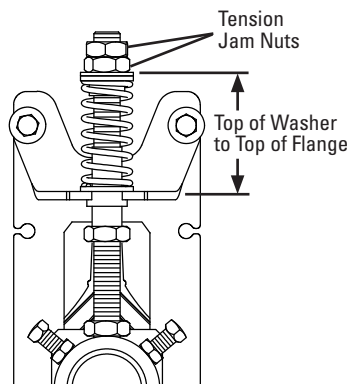

Pull-Up Tensioner Configuration (SD)

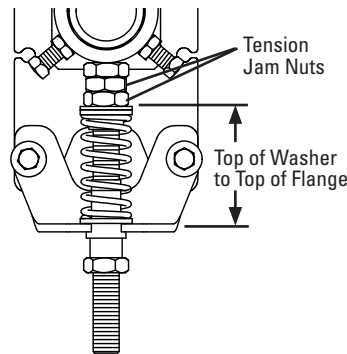

Push-Up Tensioner Configuration (SD)

### YST SD Tensioner Spring Length Chart

Blade Width	Carbide Tip	Purple or White Polyurethane Tip		Red UHT Polyurethane Tip	
	Silver Springs	Yellow Springs	Purple Springs	Yellow Springs	Purple Springs
mm	mm	mm	mm	mm	mm
450	105	83	92	79	92
600	102	73	86	70	86
750	98	67	79	64	79
900	95	57	73	57	73
1050	92	NA	67	NA	67
1200	89	NA	60	NA	60

Shading indicates preferred spring option.

### Specifications:

- Maximum Belt Speed..... 3 m/s (600 FPM)
- Usable Blade Wear Length..... 50 mm (Polyurethane)  
6 mm (Carbide)
- Blade Materials ..... **Purple:** Polyurethane (proprietary blend for abrasion resistance and long wear)  
**Red:** Polyurethane (ultra high-temp)  
**Carbide:** Tungsten Carbide
- Available for Belt Widths ..... 450 to 1200 mm. Other sizes available upon request.
- CEMA Cleaner Rating ..... Class 2 (Standard-duty with polyurethane blades)  
Class 3 (Standard-duty with Carbide blades)

# Replacement Parts List

## Y-Type™ Standard Duty Secondary Cleaner with Carbide or Polyurethane Blades

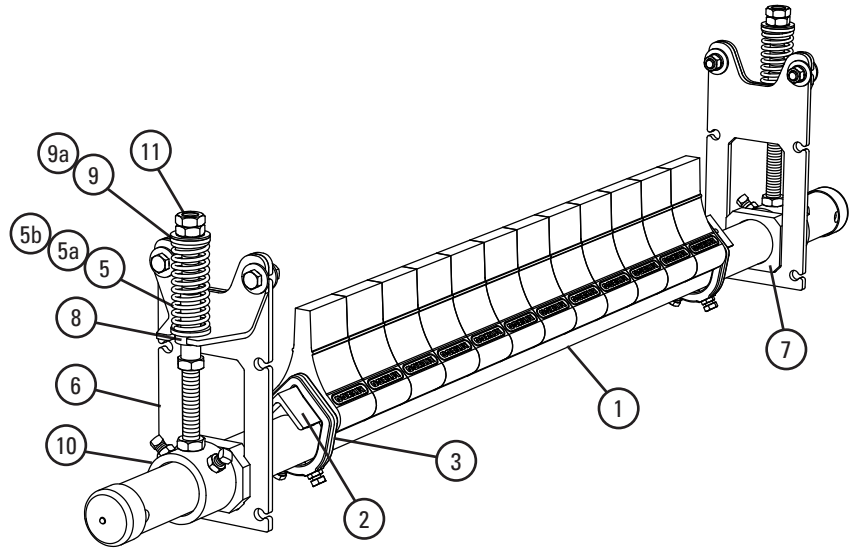
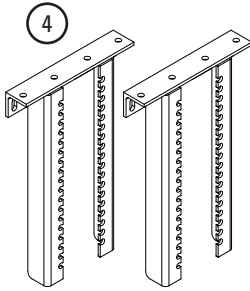

### Replacement Parts

REF	DESCRIPTION	ORDERING NUMBER	ITEM CODE	WT. KG
1	450mm Y-Type™ Pole	YTP-18/450	82932	9.2
	600mm Y-Type Pole	YTP-24/600	82933	10.3
	750mm Y-Type Pole	YTP-30/750	82934	11.5
	900mm Y-Type Pole	YTP-36/900	82935	12.6
	1050mm Y-Type Pole	YTP-42/1050	82936	13.7
	1200mm Y-Type Pole	YTP-48/1200	82937	14.9
2	450mm Y-Type Cushion Angle	YTA-18/450	82949	2.6
	600mm Y-Type Cushion Angle	YTA-24/600	82950	3.3
	750mm Y-Type Cushion Angle	YTA-30/750	82951	4.0
	900mm Y-Type Cushion Angle	YTA-36/900	82952	4.7
	1050mm Y-Type Cushion Angle	YTA-42/1050	82953	5
	1200mm Y-Type Cushion Angle	YTA-48/1200	82954	6.2
3	Y-Type Angle Clamp* (2 Clamps)	YTAC	79623	1.0
4	YST Drop Bracket Kit (Optional Brackets)	YSTDBK2	113390	14.6
5	YST Spring Yellow	YSTS-Y	79795	0.1
5a	YST Spring Purple	YSTS-P	79796	0.2
5b	YST Spring Silver (Y-Type Carbide Cleaners)	CTS-S	77743	0.2
6	YST Mounting Bracket (incl. Angle Bracket)	YSTMB	79843	1.5
7	YST Guide Block Kit (Pair)	YSTGBK	79845	0.2
8	YST Lower Bushing Kit (Pair)	YSTLBK	79846	0.0
9	YST Top Bushing Kit White (Pair)	YSTTBK-W	79847	0.0
9a	YST Top Bushing Kit Black (Pair)	YSTTBK-B	79855	0.0
10	YST Pole Mount Kit*	YSTPMK	79848	2.0
11	YST Adjusting Rod Nut Kit	YSTANK	79857	0.1

\*Hardware included  
Lead time: 2 weeks

### Replacement Parts

REF	DESCRIPTION	ORDERING NUMBER	ITEM CODE	WT. KG
-	YST Tensioner w/Yellow Spring (Pair) (incl. 2 ea. item 5, 6, 10, 11; 1 ea. items 7, 8, 9)	YST-Y	79836	8.3
-	YST Tensioner w/Purple Spring (Pair) (incl. 2 ea. item 5a, 6, 10, 11; 1 ea. items 7, 8, 9)	YST-P	79837	8.4
-	YST Tensioner w/Silver Spring (Pair) (incl. 2 ea. item 5b, 6, 10, 11; 1 ea. items 7, 8, 9a)	YST-S	79838	8.5
-	P Adjusting Bracket	PAB	75513	1.0
-	P Pole Clamp	PCB	75507	3.0
-	P Mounting Bracket Repair Kit (includes left or right mounting bracket)	PMBL (left)	75516	3.8
-		PMBR (right)	75519	3.8
-	P/R/I Mounting Kit (includes 2 each items PMB, PAB, PCB)	CCMK	78919	12

Lead time: 2 weeks

### Blades Required per Cleaner Size

mm	450	600	750	900	1050	1200
<b>No. Blades Required</b>	6	8	10	12	14	16

### Spring Tensioner Selection Chart

Cleaner Blade Width	79838 YST-S	79836 YST-Y	79837 YST-P
Carbide 450–1200mm	X		
Polyurethane 450–750mm		X	
Polyurethane 900–1200mm			X

Stock items (non-shaded) refer to (\*) for specific lead time, if not specified, standard lead time applies.  
Non-stock items (shaded) please contact Flexco for dispatch options and lead times.

U.S. Patent No. 9,586,765

www.flexco.com • toll-free phone: +1300-098-435



PRODUCT GUIDE



# Product Ordering Information

## Y-Type™ Heavy Duty Secondary Cleaner with HD Carbide or Urethane Blades

### Y-Type™ HD with Purple Polyurethane Blades and YST Tension

BELT WIDTH	ORDERING NUMBER	ITEM CODE	WT. KG
mm			
900	YTHD-900S	83120	59.4
1050	YTHD-1050S	83121	63.5
1200	YTHD-1200S	83122	68.0
1350	YTHD-1350S	83123	71.7
1500	YTHD-1500S	83124	76.2
1800	YTHD-1800S	83126	84.4

Lead time: 2 weeks

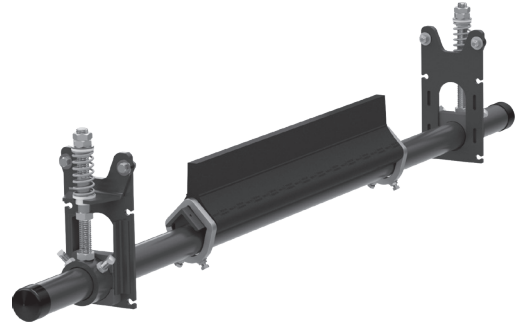

### Y-Type™ HD with Red UHT Polyurethane Blades and YST Tension

BELT WIDTH	ORDERING NUMBER	ITEM CODE	WT. KG
mm			
900	YTHDR-36S	91816	59.4
1050	YTHDR-42S	91817	63.5
1200	YTHDR-48S	91818	68.0
1350	YTHDR-54S	91819	71.7
1500	YTHDR-60S	91820	76.2
1800	YTHDR-72S	91821	84.4

Lead time: 2 weeks

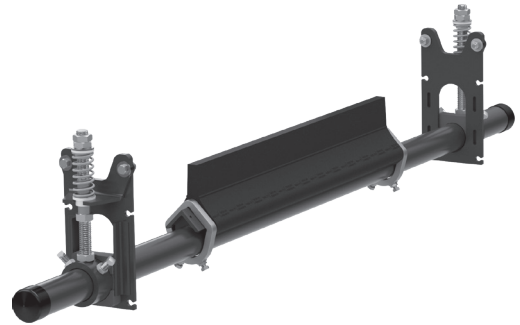

### Y-Type™ HD with Carbide Blades and Bolt Tension

BELT WIDTH	ORDERING NUMBER	ITEM CODE	WT. KG
mm			
900	YTCHD-900	83099	59.4
1050	YTCHD-1050	83100	63.5
1200	YTCHD-1200	83101	68.0
1350	YTCHD-1350	83102	71.7
1500	YTCHD-1500	83103	76.2
1800	YTCHD-1800	83105	84.4

Lead time: 2 weeks



### Y-Type™ HD with Carbide Blades and YST Tension

BELT WIDTH	ORDERING NUMBER	ITEM CODE	WT. KG
mm			
900	YTHD-TC-900S	83134	59.4
1050	YTHD-TC-1050S	83135	63.5
1200	YTHD-TC-1200S	83136	68.0
1350	YTHD-TC-1350S	83137	71.7
1500	YTHD-TC-1500S	83138	76.2
1800	YTHD-TC-1800S	83140	84.4

Lead time: 2 weeks



#### Product Notes:

- Works on reversing belts, vulcanized belts, and belts with mechanical fasteners.
- Visual Blade Tension Check: Measure the tension spring and refer to Spring Length Chart on mounting base for the correct length for best cleaning performance.
- Tensioner: Standard Duty YST Spring Tensioner for self-adjusting tensioning with easy retensioning adjustments. The tensioner can be mounted in pull-up or push-up position.
- Simple design makes changing blades fast and easy. Blades can be removed and replaced individually or all at once with the cartridge.



# Product Ordering Information

## Y-Type™ Heavy Duty Replacement Blades/Cartridges

### Replacement Blades/Cartridges - Heavy-Duty Carbide

BELT WIDTH	ORDERING NUMBER	ITEM CODE	WT. KG
mm			
-	YT-HDC*	79728	0.8
900	YCART-36/900-HDTC	79829	17.5
1050	YCART-42/1050-HDTC	79830	20.2
1200	YCART-48/1200-HDTC	79831	23.0
1350	YCART-54/1350-HDTC	79832	25.8
1500	YCART-60/1500-HDTC	79833	28.6
1800	YCART-72/1800-HDTC	79834	34.2

\*Single 75 mm blade segment  
Lead time: 2 weeks

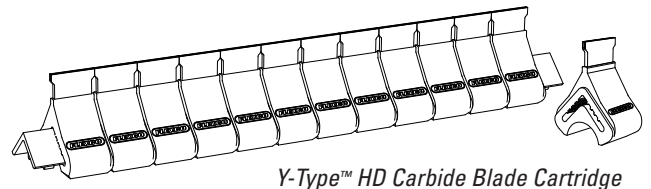

Y-Type™ HD Carbide Blade Cartridge

### Replacement Blades/Cartridges - Heavy-Duty Purple Polyurethane

BELT WIDTH	ORDERING NUMBER	ITEM CODE	WT. KG
mm			
-	YT-HDP*	79677	0.8
900	YCART-36/900-HDP	79817	16.6
1050	YCART-42/1050-HDP	79818	19.2
1200	YCART-48/1200-HDP	79819	21.9
1350	YCART-54/1350-HDP	79820	24.5
1500	YCART-60/1500-HDP	79821	27.2
1800	YCART-72/1800-HDP	79822	32.5

\*Single 75 mm blade segment  
Lead time: 2 weeks

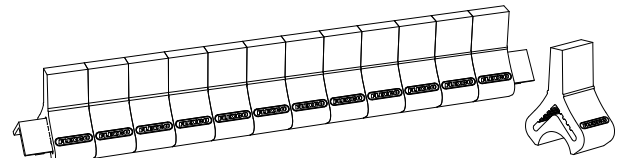

Y-Type™ HD Purple Polyurethane Blade Cartridge

### Replacement Blades/Cartridges HD Red UHT Polyurethane

BELT WIDTH	ORDERING NUMBER	ITEM CODE	WT. KG
mm			
-	YT-HDR*	91822	0.8
900	YCART-36/900-HDR	91823	16.6
1050	YCART-42/1050-HDR	91824	19.2
1200	YCART-48/1200-HDR	91825	21.8
1350	YCART-54/1350-HDR	91826	24.4
1500	YCART-60/1500-HDR	91827	27.1
1800	YCART-72/1800-HDR	91828	32.4

\*Single 75 mm blade segment  
Lead time: 2 weeks

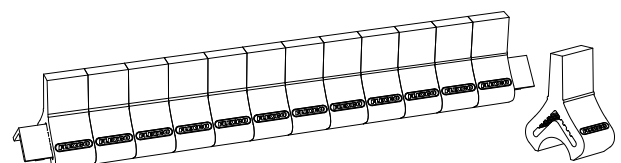

Y-Type™ HD UHT Red Polyurethane Blade Cartridge

Stock items (non-shaded) refer to (\*) for specific lead time, if not specified, standard lead time applies.  
Non-stock items (shaded) please contact Flexco for dispatch options and lead times.

# Specifications & Guidelines

## Y-Type™ Heavy Duty Secondary Cleaner with HD Carbide or Urethane Blades

### Pole Length Specifications

Cleaner Size	Pole Length	Maximum Conveyor Span
mm	mm	mm
900	2286	2083
1050	2438	2235
1200	2590	2388
1350	2743	2540
1500	2895	2692
1800	3200	2997

Pole Length - Belt +1350mm (54")  
Pole Diameter - 73mm (2-7/8")

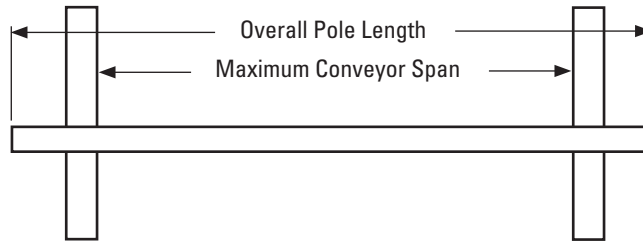

### Clearance Guidelines for Installation

Cleaner Type	Belt Width/ Cleaner Size	Horizontal Clearance Required	Vertical Clearance Required
	mm	mm	mm
Y-Type® HD Polyurethane	900-1800	133	241
Y-Type HD Carbide	900-1800	133	248

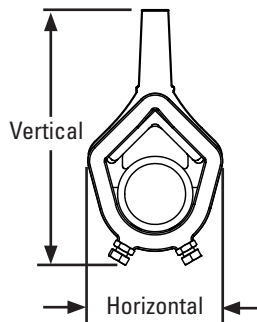

### Y-Type Blade Specifications

Cushion	Durometer	Temperature Range
Purple (Standard)	86A	-35 to 82° C
Red (Ultra High-Temp)	90A	Up to 200° C Spikes to 232° C
Carbide	N/A	-35 to 82° C

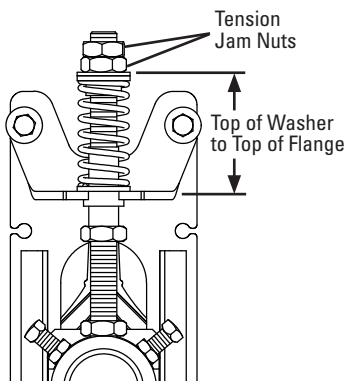

Pull-Up Tensioner Configuration (HD)

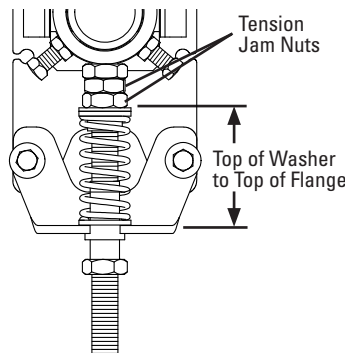

Push-Up Tensioner Configuration (HD)

### YST HD Tensioner Spring Length Chart

Blade Width	Carbide Tip		Polyurethane Tip	
	Silver Springs	Black Springs	Green Springs	Blue Springs
mm	mm	mm	mm	mm
900	98	102	76	86
1050	95	98	73	83
1200	92	95	67	79
1350	89	95	64	76
1500	86	92	NA	73
1800	83	89	NA	64

Shading indicates preferred spring option.

### Specifications:

- Maximum Belt Speed..... 3.8 m/s (750 FPM)
- Usable Blade Wear Length..... 76 mm (Polyurethane)  
10 mm (Carbide)
- Blade Materials ..... **Purple:** Polyurethane (proprietary blend for abrasion resistance and long wear)  
**Red:** Polyurethane (ultra high-temp)  
**Carbide:** Tungsten Carbide
- Available for Belt Widths ..... 900 to 1800 mm. Other sizes available upon request.
- CEMA Cleaner Rating ..... Class 3 (Heavy-duty with polyurethane or carbide blades)

# Replacement Parts List

## Y-Type™ Heavy Duty Secondary Cleaner with HD Carbide or Urethane Blades

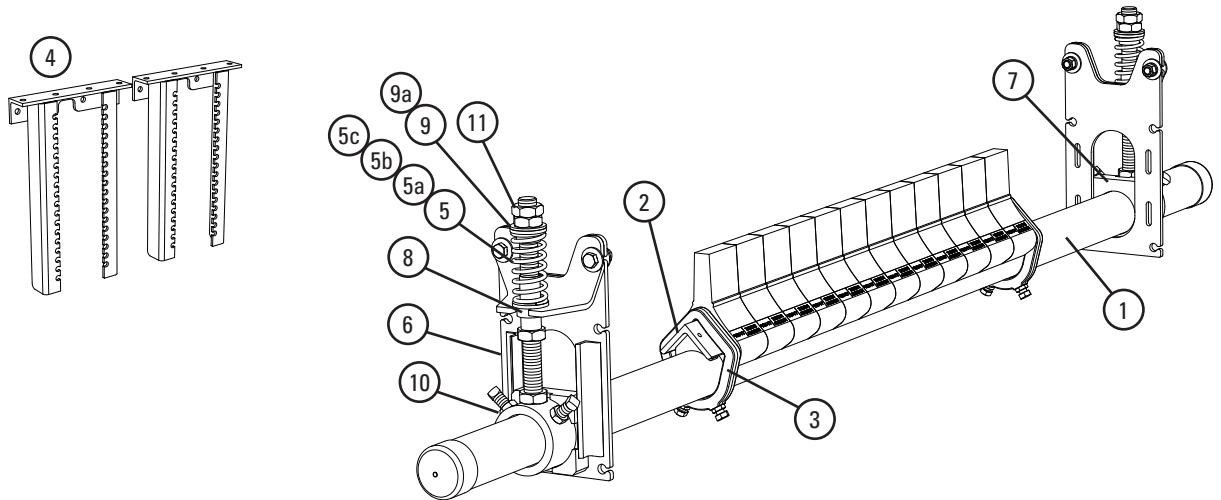

### Replacement Parts

REF	DESCRIPTION	ORDERING NUMBER	ITEM CODE	WT. KG
1	900mm Y-Type™ HD Pole	YTPHD-36/900	83106	27.3
	1050mm Y-Type HD Pole	YTPHD-42/1050	83107	28.8
	1200mm Y-Type HD Pole	YTPHD-48/1200	83108	30.4
	1350mm Y-Type HD Pole	YTPHD-54/1350	83109	31.9
	1500mm Y-Type HD Pole	YTPHD-60/1500	83110	33.5
	1800mm Y-Type HD Pole	YTPHD-72/1800	83112	35.0
2	900mm Y-Type HD Cushion Angle	YTAHD-36/900	79805	7.5
	1050mm Y-Type HD Cushion Angle	YTAHD-42/1050	79806	8.6
	1200mm Y-Type HD Cushion Angle	YTAHD-48/1200	79807	9.7
	1350mm Y-Type HD Cushion Angle	YTAHD-54/1350	79808	10.9
	1500mm Y-Type HD Cushion Angle	YTAHD-60/1500	79809	12.0
	1800mm Y-Type HD Cushion Angle	YTAHD-72/1800	79810	14.2
3	Y-Type HD Angle Clamp* (2 Clamps)	YTACHD	79835	2.2
4	YST HD Drop Bracket Kit (2 Brackets)	YSTDDBK	79850	14.6
5	YST HD Spring, Green	YSTDHS-GR	79797	0.2
5a	SST Spring, Silver	STS-S	75843	0.4
5b	YST HD Spring, Blue (for Y-Type HD Carbide Cleaners)	YSTDHS-BL	79798	0.3
5c	SST Spring, Black (for Y-Type HD Carbide Cleaners)	STS-B	75844	0.5
6	YST HD Mounting Bracket (incl. Angle Bracket)	YSTDHMB	79849	3.0
7	YST HD Guide Block Kit (Pair)	YSTDGBK	79851	0.5
8	YST HD Lower Bushing Kit (Pair)	YSTDHLBK	79852	0.05
9	YST HD Top Bushing Kit White (Pair)	YSTDHBK-W	79853	0.05
9a	YST HD Top Bushing Kit Black (Pair)	YSTDHBK-B	79856	0.05
10	YST HD Pole Mount Kit*	YSTDHDMK	79854	3.5
11	YST Adjusting Rod Nut Kit	YSTANKHD	79858	0.1

\*Hardware included  
Lead time: 4 weeks

### Replacement Parts

REF	DESCRIPTION	ORDERING NUMBER	ITEM CODE	WT. KG
-	YST Tensioner w/Silver Spring (Pair) (for belts 900–1350mm w/carbide tips) (incl. 2 ea. item 5a, 6, 10, 11; 1 ea. items 7, 8, 9)	YSTHD-S	79840	15.2
-	YST Tensioner w/Black Spring (Pair) (for belts 1500–1800mm w/carbide tips) (incl. 2 ea. item 5c, 6, 10, 11; 1 ea. items 7, 8, 9a)	YSTHD-BK	79842	15.5
-	YST Tensioner w/Green Spring (Pair) (for belts 900–1200mm w/Polyurethane tips) (incl. 2 ea. item 5, 6, 10, 11; 1 ea. items 7, 8, 9)	YSTHD-GR	79839	14.9
-	YST Tensioner w/Blue Spring (Pair) (for belts 1350–1800mm w/Polyurethane tips) (incl. 2 ea. item 5b, 6, 10, 11; 1 ea. items 7, 8, 9a)	YSTHD-BL	79841	15.0
-	P Adjusting Bracket	PAB	75513	1.0
-	P Pole Clamp	PHDCB	75510	4.0
-	P Mounting Bracket Repair Kit (includes left or right mounting bracket)	PMBL (left)	75516	3.8
-		PMBR (right)	75519	3.8
-	P/R/I Mounting Kit (includes 2 each items PMB, PAB, PHDCB)	CCMKHD	78920	16.7

### Blades Required per Cleaner Size

mm	900	1050	1200	1350	1500	1800
<b>No. Blades Required</b>	12	14	16	18	20	24

### Spring Tensioner Selection Chart

Cleaner Blade Width	Silver YSTDH-S	Black YSTDH-BK	Green YSTDH-GR	Blue YSTDH-BL
Carbide 900–1350mm	X			
Carbide 1500–1800mm		X		
Polyurethane 900–1200mm			X	
Polyurethane 1350–1800mm				X

**Stock items** (non-shaded) refer to (\*) for specific lead time, if not specified, standard lead time applies.  
 **Non-stock items** (shaded) please contact Flexco for dispatch options and lead times.

U.S. Patent No. 9,586,765

# Product Ordering Information

## Stainless Steel Y-Type™ Secondary Cleaners

### Stainless Steel Y-Type™ SD with Carbide Blades and Bolt Tensioner

BELT WIDTH	ORDERING NUMBER	ITEM CODE
mm		
600	YTC600-BT-S/S SECONDARY	67285
750	YTC750-BT-S/S SECONDARY	67286
900	YTC900-BT-S/S SECONDARY	67287
1050	YTC1050-BT-S/S SECONDARY	67288
1200	YTC1200-BT-S/S SECONDARY	67289

Lead time: 2 weeks

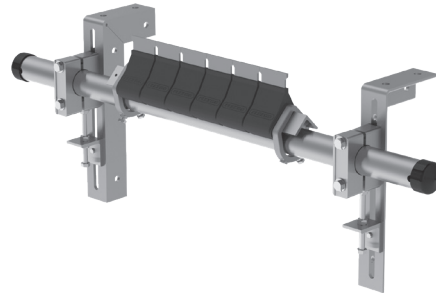

### Stainless Steel Y-Type™ HD with Carbide Blades and Bolt Tensioner

BELT WIDTH	ORDERING NUMBER	ITEM CODE
mm		
900	YTCHD900-BT-S/S SECONDARY	67290
1050	YTCHD1050-BT-S/S SECONDARY	67291
1200	YTCHD1200-BT-S/S SECONDARY	67292
1350	YTCHD1350-BT-S/S SECONDARY	67293
1500	YTCHD1500-BT-S/S SECONDARY	67294
1800	YTCHD1800-BT-S/S SECONDARY	67295

Lead time: 2 weeks

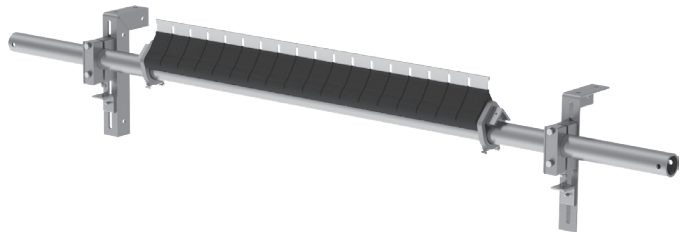

### Stainless Steel Y-Type™ HD with Carbide Blades and MST Tensioner

BELT WIDTH	ORDERING NUMBER	ITEM CODE
mm		
900	YTCHD900-MST-S/S SECONDARY	67308
1050	YTCHD1050-MST-S/S SECONDARY	67309
1200	YTCHD1200-MST-S/S SECONDARY	67310
1350	YTCHD1350-MST-S/S SECONDARY	67311
1500	YTCHD1500-MST-S/S SECONDARY	67312
1800	YTCHD1800-MST-S/S SECONDARY	67313

Lead time: 2 weeks

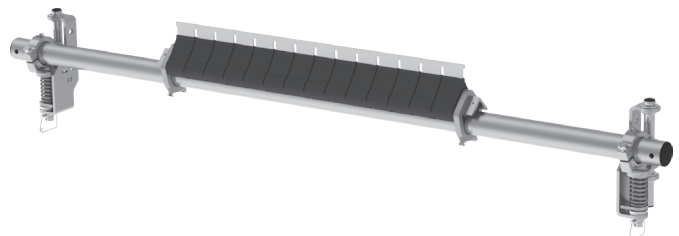

### Stainless Steel Y-Type™ HD with Polyurethane Blades and MST Tensioner

BELT WIDTH	ORDERING NUMBER	ITEM CODE
mm		
900	YTFHD900-MST-S/S SECONDARY	67314
1050	YTFHD1050-MST-S/S SECONDARY	67315
1200	YTFHD1200-MST-S/S SECONDARY	67316
1350	YTFHD1350-MST-S/S SECONDARY	67317
1500	YTFHD1500-MST-S/S SECONDARY	67318
1800	YTFHD1800-MST-S/S SECONDARY	67319

Lead time: 2 weeks



# Replacement Parts List

## Stainless Steel Y-Type™ Secondary Cleaners

### Replacement Poles

BELT WIDTH	ORDERING NUMBER	ITEM CODE
mm		
600	YPHD600-S/S POLE	67322
750	YPHD750-S/S POLE	67323
900	YPHD900-S/S POLE	64198
1050	YPHD1050-S/S POLE	64199
1200	YPHD1200-S/S POLE	64200
1350	YPHD1350-S/S POLE	64201
1500	YPHD1500-S/S POLE	64202
1800	YPHD1800-S/S POLE	64204

### Other

ORDERING NUMBER	ITEM CODE
MSTHD-S-S/S	90182
MSTHD-B-S/S	90183
MSTHD-G-S/S	90184

### Replacement Blades/Cartridges - Standard-Duty Carbide

BELT WIDTH	ORDERING NUMBER	ITEM CODE
mm		
600	YCART-S/S-24/600-SDTC	66749
750	YCART-S/S-30/750-SDTC	67750
900	YCART-S/S-36/900-SDTC	67751
1050	YCART-S/S-42/1050-SDTC	67752
1200	YCART-S/S-48/1200-SDTC	67753

### Cushion Angle

BELT WIDTH	ITEM CODE
mm	
600	67324
750	67325
900	91090
1050	91091
1200	91092

### HD Cushion Angle

BELT WIDTH	ITEM CODE
mm	
900	64205
1050	64206
1200	64207
1350	64208
1500	64209
1800	64211

### Replacement Blades/Cartridges - Heavy-Duty Carbide

BELT WIDTH	ORDERING NUMBER	ITEM CODE
mm		
900	YCART-S/S-36/900-HDTC	67411
1050	YCART-S/S-42/1050-HDTC	67412
1200	YCART-S/S-48/1200-HDTC	67413
1350	YCART-S/S-54/1350-HDTC	67414
1500	YCART-S/S-60/1500-HDTC	67415
1800	YCART-S/S-72/1800-HDTC	67416

### Cushion Angle Clamp

	ITEM CODE
SD	GR298
HD	B0536

### Replacement Blades/Cartridges - Heavy-Duty Purple Polyurethane

BELT WIDTH	ORDERING NUMBER	ITEM CODE
mm		
900	YCART-S/S-36/900-HDP	67417
1050	YCART-S/S-42/1050-HDP	67418
1200	YCART-S/S-48/1200-HDP	67419
1350	YCART-S/S-54/1350-HDP	67420
1500	YCART-S/S-60/1500-HDP	67421
1800	YCART-S/S-72/1800-HDP	67422

Stock items (non-shaded) refer to (\*) for specific lead time, if not specified, standard lead time applies.

Non-stock items (shaded) please contact Flexco for dispatch options and lead times.

# Product Ordering Information

**P-Type®**  
Secondary Cleaner

## P-Type® Secondary with V-Tips\* Powder Coated

BELT WIDTH	ORDERING NUMBER	ITEM CODE	WT. KG
mm			
450	PV450	73435	36.0
600	PV600	73004	37.0
750	PV750	73006	38.0
900	PV900	73008	41.0
1050	PV1050	73010	47.0
1200	PV1200	73012	51.0
1400	PV1400	73436	55.0
1500	PV1500	73437	58.0
1800	PVHD1800	74598	92.0
2000	PVHD2000	75452	96.0
2100	PVHD2100	74553	100.0
2400	PVHD2400	74555	110.0

\*NOTE: V-Tips can be used ONLY on vulcanised belts.  
P-Type cleaners come standard with bolt tensioners.  
Shaded items are made to order-contact Flexco customer service.

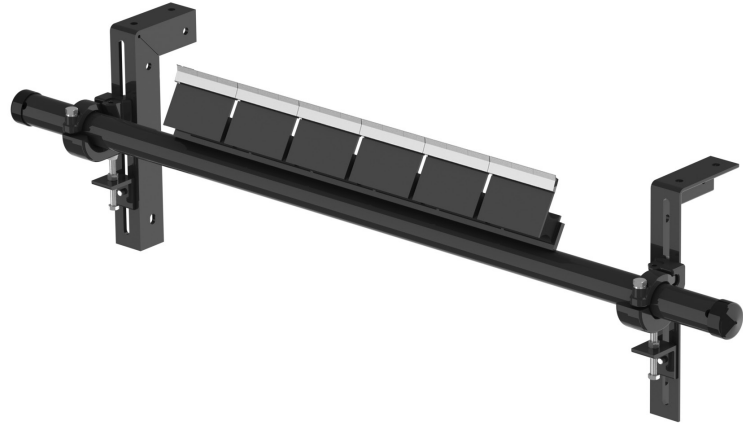

## P-Type® Secondary with V-Tips\* Stainless Steel

BELT WIDTH	ORDERING NUMBER	ITEM CODE	WT. KG
mm			
450	PV450-S/S	75323	37.0
600	PV600-S/S	75324	38.0
750	PV750-S/S	75325	39.0
900	PV900-S/S	75326	42.0
1050	PV1050-S/S	75327	48.0
1200	PV1200-S/S	75328	52.0
1400	PV1400-S/S	75329	56.0
1500	PV1500-S/S	75330	60.0
1800	PVHD1800-S/S	A1603	95.0
2000	PVHD2000-S/S	A2046	99.0
2100	PVHD2100-S/S	A1604	103.0
2400	PVHD2400-S/S	A1605	114.0

\*NOTE: V-Tips can be used ONLY on vulcanised belts.  
P-Type cleaners come standard with bolt tensioners.  
Shaded items are made to order-contact Flexco customer service.

## Tips Required Per Cleaner Size

BELT WIDTH	BLADE COVERAGE	NO. V-TIPS REQUIRED
mm	mm	
450	450	3
600	600	4
750	750	5
900	900	6
1050	1050	7
1200	1200	8
1400	1350	9
1500	1500	10
1800	1800	12
2000	1950	13
2100	2100	14
2400	2400	16

## Tips Required Per Cleaner Size

mm	450	600	750	900	1050	1200	1350	1500	1800
No. C-Tips or V-Tips Required	3	4	5	6	7	8	9	10	12

## Product Notes:

- C-Tip: specially formulated tungsten carbide blades to work with mechanical fasteners.
- V-Tip: for use on vulcanised belts only.
- Compact design: fits in small transfer areas and tight chutes.

Stock items (non-shaded) refer to (\*) for specific lead time, if not specified, standard lead time applies.  
Non-stock items (shaded) please contact Flexco for dispatch options and lead times.

# Replacement Parts List

**P-Type®**  
Secondary Cleaner

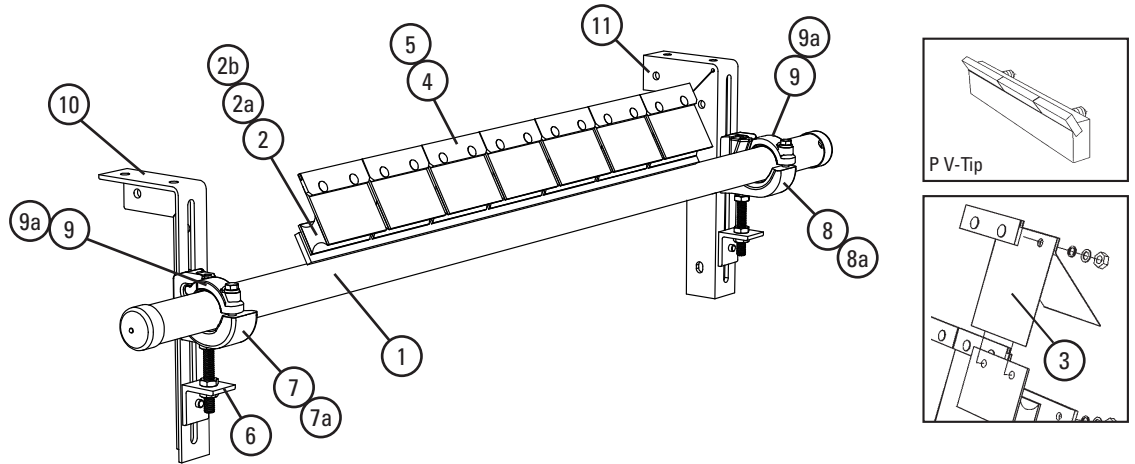

## Replacement Parts

REF	DESCRIPTION	BELT WIDTH mm	POLE LENGTH mm	POWDER COATED			STAINLESS STEEL		
				ORDERING NUMBER	ITEM CODE	WT. KG	ORDERING NUMBER	ITEM CODE	WT. KG
1	P-Type® Pole 60mm Pole Diameter	450	1250	PP450	73003	10.0	PP450-S/S	75382	10.0
		600	1350	PP600	73005	11.0	PP600-S/S	75383	11.0
		750	1500	PP750	73007	13.0	PP750-S/S	75384	13.0
		900	1650	PP900	73009	15.0	PP900-S/S	75385	15.0
		1050	1800	PP1050	73011	20.0	PP1050-S/S	75386	21.0
	P-Type Pole 73mm Pole Diameter	1200	1950	PP1200	73013	20.0	PP1200-S/S	75387	23.0
		1400	2200	PP1400	73015	24.0	PP1400-S/S	75388	25.0
		1500	2350	PP1500	73016	25.0	PP1500-S/S	75389	26.0
		1800	2650	PPHD1800	74597	27.0	PPHD1800-S/S	A1781	28.0
		2000	2850	PPHD2000	74556	31.0	PPHD2000 -S/S	A2120	29.0
		2100	2950	PPHD2100	A2803	38.0	PPHD2100 -S/S	A1613	39.0
2400	3250	PPHD2400	74557	44.0	PPHD2400 -S/S	A1775	45.0		
2	P Cushion			PHA	73626	1.0	PHSC-S/S	73433	1.0
2a	P-Type Powerflex Cushion						PFC-P-S/S	79289	1.9
2b	HD P-Type Cushion			HDPHC	61003	1.7	HDPHSC-S/S	61001	1.9
3	P Polyshield			PPS6	73024	1.0	PSSS	74773	1.0
-	PU150 P-Type Poly Tip FRAS			FRPU150	61742	1.0			
4	C-Tip (for mechanically spliced and vulcanised belts)			ICT6	74535	0.4			
5	P V-Tip* (for vulcanised belts only)			PSA150	73156	0.4	PVT6-S/S	75420	0.4
-	Extra Life P V-Tip - 15mm			PSA150-EL15	62094	0.6			
-	Extra Life P V-Tip - 20mm			PSA150-XL	67777	0.8			
6	Adjusting Bracket Kit* (1ea.)			PAB	75513	0.7	PAB-S/S	75515	0.7
7	Pole Clamp Kit Left* (1ea.) (incl. item 9) (for sizes 450-1200mm)			CCKL	79224	3.1	CCKL-S/S	79226	3.1
8	Pole Clamp Kit Right* (1ea.) (incl. item 9) (for sizes 450-1200mm)			CCKR	79228	3.1	CCKR-S/S	79230	3.1
9	Cradle Clamp Top Strap (1ea.) (for use on L or R Pole Clamp Kit)			CCKTS	79232	0.5	CCKTS-S/S	79234	0.5
10	Mounting Bracket Kit Left			PMBL	75516	3.8	PMBL-S/S	75518	3.8
11	Mounting Bracket Kit Right			PMBR	75519	3.8	PMBR-S/S	75521	3.8
-	Cradle Clamp Mounting Kit* (for sizes 450-1200mm) (incl. 2 ea. item 6, and 1 ea. items 7, 8, 10 & 11)			CCMK	78919	15.0	CCMK-S/S	78921	15.0
<b>HEAVY-DUTY COMPONENTS</b>									
7a	HD Pole Clamp Kit Left* (1ea.) (incl. item 9a) (for sizes 1400-2400mm)			CCKHDL	79225	4.0	CCKHDL-S/S	79227	4.0
8a	HD Pole Clamp Kit Right* (1ea.) (incl. item 9a) (for sizes 1400-2400mm)			CCKHDR	79229	4.0	CCKHDR-S/S	79231	4.0
9a	HD Cradle Clamp Top Strap (1ea.) (for use on L or R HD Pole Clamp Kit)			CCKHDTS	79233	0.8	CCKHDTS-S/S	73235	0.8
-	HD Cradle Clamp Mounting Kit* (for sizes 1400-2400mm) (incl. 2 ea. item 6, and 1 ea. items 7a, 8a, 10 & 11)			CCMKHD	78920	16.7	CCMKHD-S/S	78922	16.7

\*Hardware included

Stock items (non-shaded) refer to (\*) for specific lead time, if not specified, standard lead time applies.  
Non-stock items (shaded) please contact Flexco for dispatch options and lead times.



# Product Ordering Information

## R-Type® Reversing Secondary Cleaner

### R-Type® Reversing with V-Tips\*

BELT WIDTH mm	ORDERING NUMBER	ITEM CODE	WT. KG
450	RV450	74633	36.0
600	RV600	74634	37.0
750	RV750	74635	38.0
900	RV900	74636	41.0
1050	RV1050	74637	47.0
1200	RV1200	74638	51.0
1400	RV1400	74639	55.0
1500	RV1500	74640	28.0
1800	RVHD1800	74642	92.0
2000	RVHD2000	75463	94.0
2100	RVHD2100	74643	100.0
2400	RVHD2400	74644	110.0

\*NOTE: V-Tips can be used ONLY on vulcanised belts. Shaded items are made to order-contact Flexco customer service.



### Stainless Steel R-Type® Reversing with V-Tips\*

BELT WIDTH mm	ORDERING NUMBER	ITEM CODE	WT. KG
450	RV450-S/S	75341	37.0
600	RV600-S/S	75342	38.0
750	RV750-S/S	75343	39.0
900	RV900-S/S	75344	42.0
1050	RV1050-S/S	75345	48.0
1200	RV1200-S/S	75346	57.0
1400	RV1400-S/S	75347	56.0
1500	RV1500-S/S	75348	60.0
1800	RVHD1800-S/S	A1626	95.0
2100	RVHD2100-S/S	A1628	103.0
2400	RVHD2400-S/S	A1610	114.0

\*NOTE: V-Tips can be used ONLY on vulcanised belts. Shaded items are made to order-contact Flexco customer service.

### Tips Required Per Cleaner Size

BELT WIDTH mm	BLADE COVERAGE mm	NO. C-TIPS OR V-TIPS REQUIRED
450	450	3
600	600	4
750	750	5
900	900	6
1050	1050	7
1200	1200	8
1500	1500	10
1800	1800	12
2000	1950	13
2100	2000	14
2400	2400	16

### Product Notes:

- Two-way cushions allow cleaning in both directions.
- Tungsten carbide tips for long wear and superior cleaning.

Stock items (non-shaded) refer to (\*) for specific lead time, if not specified, standard lead time applies.  
Non-stock items (shaded) please contact Flexco for dispatch options and lead times.

# Replacement Parts List

## R-Type® Reversing Secondary Cleaner

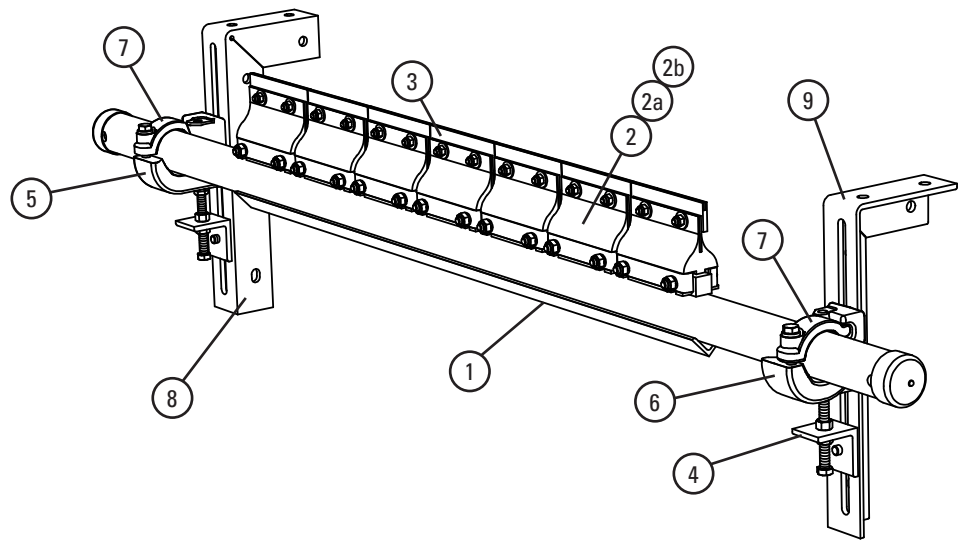
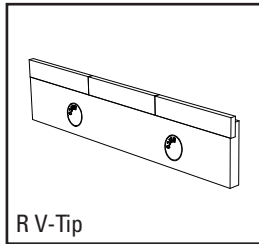

### Replacement Parts

REF	DESCRIPTION	BELT WIDTH mm	POLE LENGTH mm	POWDER COATED			STAINLESS STEEL		
				ORDERING NUMBER	ITEM CODE	WT. KG	ORDERING NUMBER	ITEM CODE	WT. KG
1	R-Type® Pole 60mm Pole Diameter	450	1250	RP450	74604	10.0	RP450-S/S	75400	10.0
		600	1350	RP600	74605	11.0	RP600-S/S	75401	11.0
		750	1500	RP750	74606	13.0	RP750-S/S	75402	13.0
		900	1650	RP900	74607	15.0	RP900-S/S	75403	15.0
		1050	1800	RP1050	74608	20.0	RP1050-S/S	75404	21.0
	R-Type Pole 73mm Pole Diameter	1200	1950	RP1200	74609	22.0	RP1200-S/S	75405	23.0
		1400	2200	RP1400	74610	24.0	RP1400-S/S	75406	25.0
		1500	2350	RP1500	74611	25.0	RP1500-S/S	75407	26.0
		1800	2650	RPHD1800	74613	27.0	RPHD1800-S/S	A1575	28.0
		2000	2850	RPHD2000	74614	31.0	RPHD2000-S/S	61270	29.0
	2100	2950	RPHD2100	A2527	38.0	RPHD2100-S/S	A1629	39.0	
	2400	3250	RPHD2400	74615	44.0	RPHD2400-S/S	61271	45.0	
2	R Cushion			RSA	76249	1.0	RC-S/S	76250	1.0
2a	HD R Cushion			RSA-HD	69520	1.3			
2b	HD R Cushion - Stainless Steel						RC-HD-S/S	69521	1.5
3	R - V-Tip (for vulcanised belts only)			RSA150	73628	0.4	RVT6-S/S	76205	0.4
3a	Extra Life R - V-Tip (15mm) (for vulcanised belts only)			RSA150-EL15	61141	0.6			
3b	Extra Life R - V-Tip (20mm) (for vulcanised belts only)			RSA150-XL	67776	0.7			
-	C-Tip (for mechanically spliced and vulcanised belts)			ICT6	74535	0.4			
4	Adjusting Bracket Kit* (1ea.)			PAB	75513	0.7	PAB-S/S	75515	0.7
5	Pole Clamp Kit Left* (1ea.) (incl. item 7) (for sizes 450–1200mm)			CCKL	79224	3.1	CCKL-S/S	79226	3.1
6	Pole Clamp Kit Right* (1ea.) (incl. item 7) (for sizes 450–1200mm)			CCKR	79228	3.1	CCKR-S/S	79230	3.1
7	Cradle Clamp Top Strap (1ea.) (for use on L or R Pole Clamp Kit)			CCKTS	79232	0.5	CCKTS-S/S	79234	0.5
8	Mounting Bracket Kit Left			PMBL	75516	3.8	PMBL-S/S	75518	3.8
9	Mounting Bracket Kit Right			PMBR	75519	3.8	PMBR-S/S	75521	3.8
-	Cradle Clamp Mounting Kit* (for sizes 450–1200mm) (incl. 2 ea. item 6, and 1 ea. items 7, 8, 10 & 11)			CCMK	78919	15.0	CCMK-S/S	78921	15.0
<b>Heavy-Duty Components</b>									
-	HD Pole Clamp Kit Left* (1ea.) (incl. item 8) (for sizes 1200–2400mm)			CCKHDL	79225	4.0	CCKHDL-S/S	79227	4.0
-	HD Pole Clamp Kit Right* (1ea.) (incl. item 9) (for sizes 1200–2400mm)			CCKHDR	79229	4.0	CCKHDR-S/S	79231	4.0
-	HD Cradle Clamp Top Strap (1ea.) (for use on L or R HD Pole Clamp Kit)			CCKHDTS	79233	0.8	CCKHDTS-S/S	73235	0.8
-	HD Cradle Clamp Mounting Kit* (for sizes 1200–2400mm) (incl. 2 ea. item 6, and 1 ea. items 7, 8, 10 & 11)			CCMKHD	78920	16.7	CCMKHD-S/S	78922	16.7

\*Hardware included  
For additional sizes contact Flexco.

Stock items (non-shaded) refer to (\*) for specific lead time, if not specified, standard lead time applies.  
Non-stock items (shaded) please contact Flexco for dispatch options and lead times.

# Product Ordering Information

## FMS Heavy-Duty Secondary Cleaner (MST Tensioners)



### FMS Secondary with V-Tips (MST)

BELT WIDTH	ORDERING NUMBER	ITEM CODE	WT. KG
mm			
600	FMS-600V	79647	44.4
750	FMS-750V	79648	49.3
900	FMS-900V	79649	54.3
1050	FMS-1050V	79650	59.2
1200	FMS-1200V	79651	64.1
1350	FMS-1350V	79652	69.0
1500	FMS-1500V	79653	73.9
1800	FMS-1800V	79654	83.6

### FMS Secondary with V-Tips (MST) Stainless Steel

BELT WIDTH	ORDERING NUMBER	ITEM CODE	WT. KG
mm			
600	FMS-600V-S/S	66106	44.9
750	FMS-750V-S/S	66107	49.8
900	FMS-900V-S/S	66108	54.8
1050	FMS-1050V-S/S	66109	59.7
1200	FMS-1200V-S/S	66110	64.6
1350	FMS-1350V-S/S	66111	69.5
1500	FMS-1500V-S/S	66112	74.4
1800	FMS-1800V-S/S	66113	84.1

For 2100 mm and 2400 mm options, please contact Flexco for pricing and availability. Lead time 3 weeks

### FMS Secondary with EL V-Tips (MST)

BELT WIDTH	ORDERING NUMBER	ITEM CODE	WT. KG
mm			
600	FMS-600-EL15	65660	44.4
750	FMS-750-EL15	65661	49.3
900	FMS-900-EL15	65662	54.3
1050	FMS-1050-EL15	65663	59.2
1200	FMS-1200-EL15	65664	64.1
1350	FMS-1350-EL15	65665	69.0
1500	FMS-1500-EL15	65666	73.9
1800	FMS-1800-EL15	65667	83.6

### FMS Secondary with EL V-Tips (MST) Stainless Steel

BELT WIDTH	ORDERING NUMBER	ITEM CODE	WT. KG
mm			
600	FMS-600-EL15-S/S	65670	44.9
750	FMS-750-EL15-S/S	65671	49.8
900	FMS-900-EL15-S/S	65672	54.8
1050	FMS-1050-EL15-S/S	65673	59.7
1200	FMS-1200-EL15-S/S	65674	64.6
1350	FMS-1350-EL15-S/S	65675	69.5
1500	FMS-1500-EL15-S/S	65676	74.4
1800	FMS-1800-EL15-S/S	65677	84.1

For 2100mm and 2400mm options, please contact Flexco for pricing and availability. Lead time 3 weeks

### Replacement Tips

ORDERING NUMBER	ITEM CODE	WT. KG
RSA150	73628	0.4
RVT6-S/S	76205	0.4
RSA150-EL15	61141	0.4
RSA150-XL	67776	0.7
ICT6	74535	0.4

### Tips Required Per Cleaner Size

mm	450	600	750	900	1050	1200	1350	1500	1800
No. C-Tips or V-Tips Required	3	4	5	6	7	8	9	10	12

Stock items (non-shaded) refer to (\*) for specific lead time, if not specified, standard lead time applies.  
 Non-stock items (shaded) please contact Flexco for dispatch options and lead times.

# Specifications & Guidelines

## Pole Length Specifications\*

CLEANER SIZE	BLADE WIDTH	POLE LENGTH	MAXIMUM CONVEYOR SPAN
mm	mm	mm	mm
600	600	1350	1100
750	750	1500	1250
900	900	1650	1400
1050	1050	1800	1550
1200	1200	1950	1700
1350	1350	2100	1850
1500	1500	2350	2100
1800	1800	2650	2400

\*For special extra long pole length requirements a Pole Extender Kit (#76024) is available that provides 750mm of extended pole length.  
Pole Diameter - 73mm

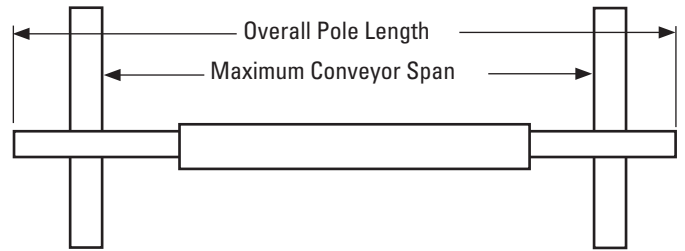

## Clearance Guidelines for Installation

HORIZONTAL CLEARANCE REQUIRED	VERTICAL CLEARANCE REQUIRED
mm	mm
89	245

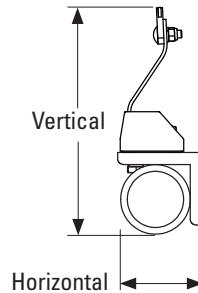

## MST Spring Length Chart

Blade Width	White Springs	Silver Springs	Black Springs
mm	mm	mm	mm
450	73	89	89
600	67	86	89
750	60	83	86
900	54	79	83
1050	N/A	76	79
1200	N/A	73	79
1350	N/A	70	76
1500	N/A	70	73
1800	N/A	N/A	70

Shading indicates preferred spring option.

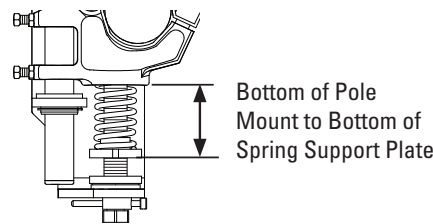

## Specifications

- Maximum Belt Speed .....5 m/s
- Temperature Rating .....-35 to 82°C
- Usable Blade Wear Length.....9 mm
- Blade Materials .....C-Tip: Impact Resistant Tungsten Carbide (works with mechanical fasteners)  
.....V-Tip: Long Life Tungsten Carbide (for vulcanized belts only)
- Available for Belt Widths .....600 to 2400 mm. Other sizes available upon request
- CEMA Cleaner Rating .....Class 4

# Replacement Parts List

## FMS Heavy-Duty Secondary Cleaner

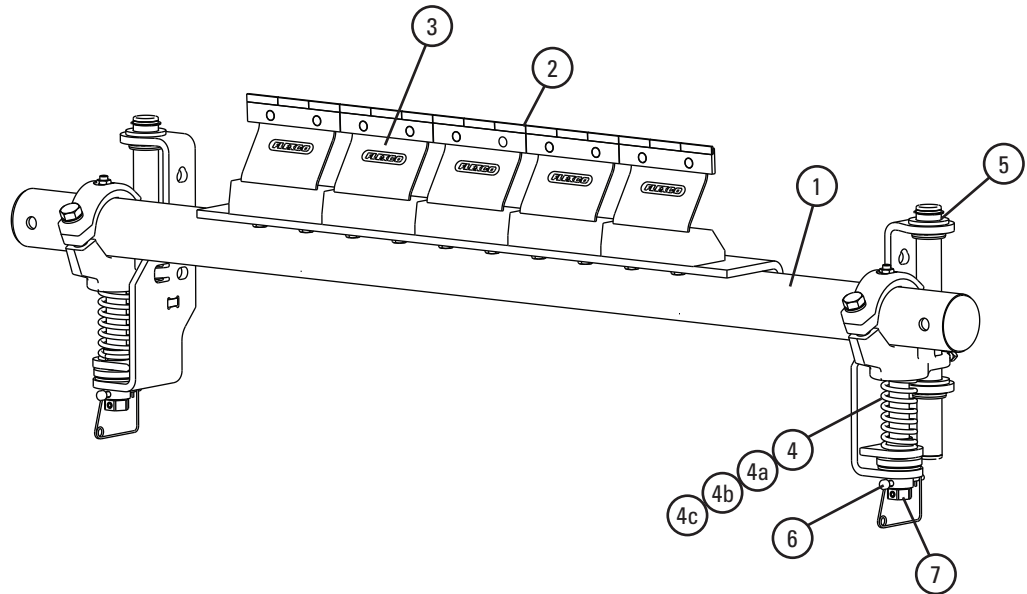

### Replacement Parts

REF	DESCRIPTION		ORDERING NUMBER	ITEM CODE	WT. KG	ORDERING NUMBER	ITEM CODE	WT. KG
	Belt Width	Pole Length						
	mm	mm						
1	600	1350	MHS-P600*	77499	21.0	MHS-P600S/S*	77508	21.5
	750	1500	MHS-P750*	77500	23.5	MHS-P750S/S*	77509	24.0
	900	1650	MHS-P900*	77501	26.0	MHS-P900S/S*	77510	26.5
	1050	1800	MHS-P1050*	77502	28.5	MHS-P1050S/S*	77511	29.0
	1200	1950	MHS-P1200*	77527	31.0	MHS-P1200S/S*	77528	31.8
	1350	2100	MHS-P1350*	77503	33.5	MHS-P1350S/S*	77512	34.3
	1500	2350	MHS-P1500*	77504	36.0	MHS-P1500S/S*	77513	36.8
	1800	2650	MHS-P1800*	77505	38.5	MHS-P1800S/S*	77514	39.3
2	R - V-Tip (for vulcanised belts only)		RSA150	73628	0.4	RVT6-S/S	76205	0.4
	Extra Life R - V-Tip (15mm) (for vulcanised belts only)		RSA150-EL15	61141	0.4			
	Extra Life R - V-Tip (20mm) (for vulcanised belts only)		RSA150-XL	67776	0.7			
	C-Tip (for mechanically spliced and vulcanised belts)		ICT6	74535	0.4			
3	FMS Cushion Kit		FMSC2	91444	1.9	FMSC2	91444	1.9
4	Tension Spring - White (1 ea.) for belts 450–750mm		STS-W	75846	0.2	STS-W-S/S	77630	0.2
4a	Tension Spring - Silver (1 ea.) for belts 900–1350mm		STS-S	75843	0.4	STS-S-S/S	77631	0.4
4b	Tension Spring - Black (1 ea.) for belts 1500–1800mm		STS-B	75844	0.5	STS-B-S/S	77632	0.5
4c	Tension Spring - Gold (1 ea.) for belts over 2100mm		STS-G	78142	0.5	STS-G-S/S	79057	0.5
5	MST Bushing Kit (incl. 4 bushings)		MSTBBK	63067	0.1	MSTBBK	63067	0.1
6	MST Lock Pin		MSTLP	64930	0.1	MSTLP	64930	0.1
7	MST Adjusting Mechanism		MSTAM	79435	0.5	MSTAM-S/S	64931	0.5
-	MST HD Tensioner w/White Spring		MSTHD-W	79431	16.7	MSTHD-W-S/S	90181	16.7
-	MST HD Tensioner w/Silver Spring		MSTHD-S	79432	17.0	MSTHD-S-S/S	90182	17.0
-	MST HD Tensioner w/Black Spring		MSTHD-B	79433	17.3	MSTHD-B-S/S	90183	17.3
-	MST HD Tensioner w/Gold Spring		MSTHD-G	63020	17.3	MSTHD-G-S/S	90184	17.3

For 2100 mm and 2400 mm options, please contact Flexco for pricing and availability.

\*Lead time 3 weeks

Stock items (non-shaded) refer to (\*) for specific lead time, if not specified, standard lead time applies.  
 Non-stock items (shaded) please contact Flexco for dispatch options and lead times.

# Product Ordering Information

## MHS - MST Heavy Duty Secondary Cleaner

### MHS HD with MST Tensioner - Mild Steel

BELT WIDTH mm	ORDERING NUMBER	ITEM CODE	TIP WIDTH mm	POLE LENGTH mm	WT. KG
600	MHS-600-MST	64020	600	1350	44.4
750	MHS-750-MST	64021	750	1500	49.3
900	MHS-900-MST	64022	900	1650	54.3
1050	MHS-1050-MST	64023	1050	1800	59.2
1200	MHS-1200-MST	64024	1200	1950	64.1
1350	MHS-1350-MST	64025	1350	2100	69.0
1500	MHS-1500-MST	64026	1500	2350	73.9
1800	MHS-1800-MST	64027	1800	2650	83.6
2100	MHS-2100-MST	64028	2100	3200	95.7
2400	MHS-2400-MST	64029	2400	3250	103.2

Lead time 3 weeks

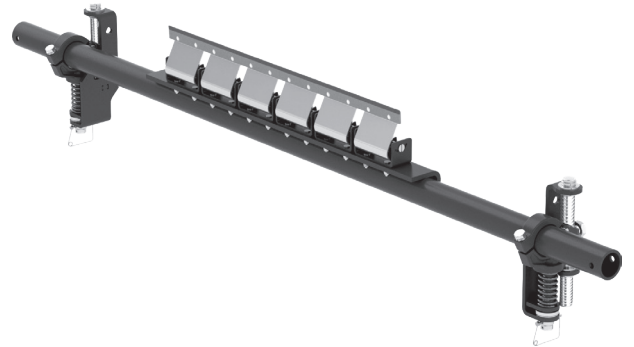

### MHS HD with MST Tensioner - Stainless Steel

BELT WIDTH mm	ORDERING NUMBER	ITEM CODE	TIP WIDTH mm	POLE LENGTH mm	WT. KG
600	MHS-600-MST-S/S	64030	600	1350	44.9
750	MHS-750-MST-S/S	64031	750	1500	49.8
900	MHS-900-MST-S/S	64032	900	1650	54.8
1050	MHS-1050-MST-S/S	64033	1050	1800	59.7
1200	MHS-1200-MST-S/S	64034	1200	1950	64.6
1350	MHS-1350-MST-S/S	64035	1350	2100	69.5
1500	MHS-1500-MST-S/S	64036	1500	2350	74.4
1800	MHS-1800-MST-S/S	64037	1800	2650	84.1
2100	MHS-2100-MST-S/S	64038	2100	3200	96.2
2400	MHS-2400-MST-S/S	64039	2400	3250	103.7

Lead time 3 weeks

### Tips Required Per Cleaner Size

mm	450	600	750	900	1050	1200	1350	1500	1800
No. C-Tips or V-Tips Required	3	4	5	6	7	8	9	10	12

### Product Notes:

- Heavy-duty design to deliver maximum cleaning efficiency on the most demanding, abusive beltlines.
- Pole Length: Belt width plus 1350 mm. For longer requirements, see accessories - Pole Extender Kit (page 124).
- Patented PowerFlex™ cushion design to maintain continuous blade-to-belt contact and quick relief from passing mechanical splices.
- V-Tips are for vulcanized belts only.
- Visual Blade Tension Check: Measure the tension spring and refer to Spring Length Chart on mounting base for the correct length for best cleaning performance.
- Tensioner: MST Spring Tensioner for self-adjusting tensioning with easy retensioning adjustments.
- To make cleaner installation easier and quicker, see Optional Mounting Kits (page 124).

Stock items (non-shaded) refer to (\*) for specific lead time, if not specified, standard lead time applies.

Non-stock items (shaded) please contact Flexco for dispatch options and lead times.

# Replacement Parts List

## MHS - MST Heavy Duty Secondary Cleaner

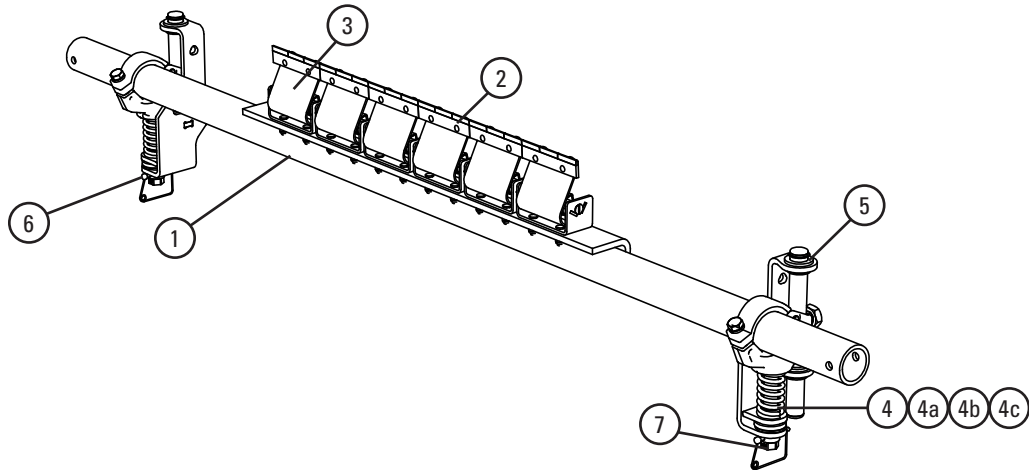

### Replacement Parts

REF	DESCRIPTION		MILD STEEL			STAINLESS STEEL		
	BELT WIDTH	POLE LENGTH	ORDERING NUMBER	ITEM CODE	WT. KG	ORDERING NUMBER	ITEM CODE	WT. KG
	mm	mm						
1	600	1350	MHS-P600	77499	23.5	MHS-P600S/S	77508	24.0
	750	1500	MHS-P750	77500	26.0	MHS-P750S/S	77509	26.5
	900	1650	MHS-P900	77501	28.5	MHS-P900S/S	77510	29.0
	1050	1800	MHS-P1050	77502	31.0	MHS-P1050S/S	77511	31.7
	1200	1950	MHS-P1200	77527	33.5	MHS-P1200S/S	77528	34.3
	1350	2100	MHS-P1350	77503	36.0	MHS-P1350S/S	77512	36.8
	1500	2350	MHS-P1500	77504	38.5	MHS-P1500S/S	77513	39.3
	1800	2650	MHS-P1800	77505	43.5	MHS-P1800S/S	77514	44.4
	2100	3200	MHS-P2100	77506	51.0	MHS-P2100S/S	77515	52.0
	2400	3250	MHS-P2400	77507	58.0	MHS-P2400S/S	77516	59.3
2	V-Tip (suits vulcanised belt)		RSA150	73628	0.4	N/A	N/A	—
	Extra Life R - V-Tip (15mm) (for vulcanised belts only)		RSA150-EL15	61141	0.4	RVT6-S/S	76205	0.4
	Extra Life R - V-Tip (20mm) (for vulcanised belts only)		RSA150-XL	67776	0.7	N/A	N/A	—
	C-Tip (suits mechanical fastened belt)		ICT6	74535	0.4	N/A	N/A	—
-	Poly Tip Kit		PTK	65746	0.5	PTK	65746	0.5
3	PowerFlex™ Cushion		SPFC	79200	2.0	SPFC-S/S	79201	2.0
4	Tension Spring - White (1 ea.) for belts 450–750mm		STS-W	75846	0.2	STS-W-S/S	77630	0.2
4a	Tension Spring - Silver (1 ea.) for belts 900–1350mm		STS-S	75843	0.4	STS-S-S/S	77631	0.4
4b	Tension Spring - Black (1 ea.) for belts 1500–1800mm		STS-B	75844	0.5	STS-B-S/S	77632	0.5
4c	Tension Spring - Gold (1 ea.) for belts over 2100mm		STS-G	78142	0.5	STS-G-S/S	79057	0.5
5	MST Bushing Kit (incl. 4 bushings)		MSTBBK	63067	0.1	MSTBBK	63067	0.1
6	MST Lock Pin		MSTLP	64930	0.1	MSTLP	64930	0.1
7	MST Adjustment Mechanism		MSTAM	79435	0.5	MSTAM-S/S	64931	0.5
-	MST HD Tensioner w/White Spring		MSTHD-W	79431	16.7	MSTHD-SS-W	90181	16.7
-	MST HD Tensioner w/Silver Spring		MSTHD-S	79432	17.0	MSTHD-SS-S	90182	17.0
-	MST HD Tensioner w/Black Spring		MSTHD-B	79433	17.3	MSTHD-SS-B	90183	17.3
-	MST HD Tensioner w/Gold Spring		MSTHD-G	63020	17.3	MSTHD-SS-G	90184	17.3

### MST Spring Tensioner Selection Chart

CLEANER SIZE	White Spring	Silver Spring	Black Spring	Gold Spring
MHS 450 – 750mm	X			
MHS 900–1350mm		X		
MHS 1500–1800mm			X	
MHS 1800–2400mm				X

Stock items (non-shaded) refer to (\*) for specific lead time, if not specified, standard lead time applies.  
Non-stock items (shaded) please contact Flexco for dispatch options and lead times.



# Product Ordering Information

## MHS - BT Heavy Duty Secondary Cleaner

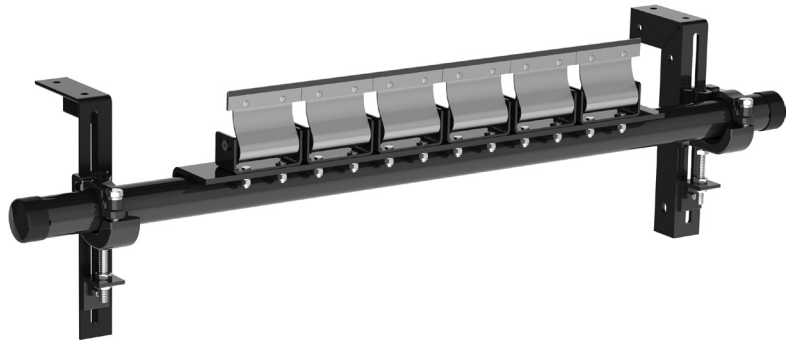

### MHS HD with Bolt Tensioner (MHS-BT) Mild Steel

BELT WIDTH	ORDERING NUMBER	ITEM CODE	TIP WIDTH	POLE LENGTH	WT. KG
mm			mm	mm	
600	MHS-600BTV	77481	600	1350	44.4
750	MHS-750BTV	77482	750	1500	49.3
900	MHS-900BTV	77483	900	1650	54.3
1050	MHS-1050BTV	77484	1050	1800	59.2
1200	MHS-1200BTV	77525	1200	1950	64.1
1350	MHS-1350BTV	77485	1350	2100	69.0
1500	MHS-1500BTV	77486	1500	2350	73.9
1800	MHS-1800BTV	77487	1800	2650	83.6
2100	MHS-2100BTV	77488	2100	3200	95.7
2400	MHS-2400BTV	77489	2400	3250	103.2

Lead time: 3 weeks

### MHS HD with Bolt Tensioner (MHS-BT) Stainless Steel

BELT WIDTH	ORDERING NUMBER	ITEM CODE	TIP WIDTH	POLE LENGTH	WT. KG
mm			mm	mm	
600	MHS-600BTV-S/S	77490	600	1350	45.3
750	MHS-750BTV-S/S	77491	750	1500	50.3
900	MHS-900BTV-S/S	77492	900	1650	55.3
1050	MHS-1050BTV-S/S	77493	1050	1800	60.4
1200	MHS-1200BTV-S/S	77526	1200	1950	65.4
1350	MHS-1350BTV-S/S	77494	1350	2100	70.4
1500	MHS-1500BTV-S/S	77495	1500	2350	75.4
1800	MHS-1800BTV-S/S	77496	1800	2650	85.3
2100	MHS-2100BTV-S/S	77497	2100	3200	97.6
2400	MHS-2400BTV-S/S	77498	2400	3250	105.3

Lead time: 3 weeks

### Tips Required Per Cleaner Size

mm	450	600	750	900	1050	1200	1350	1500	1800
No. C-Tips or V-Tips Required	3	4	5	6	7	8	9	10	12

Stock items (non-shaded) refer to (\*) for specific lead time, if not specified, standard lead time applies.

Non-stock items (shaded) please contact Flexco for dispatch options and lead times.

# Replacement Parts List

## MHS - BT Heavy Duty Secondary Cleaner

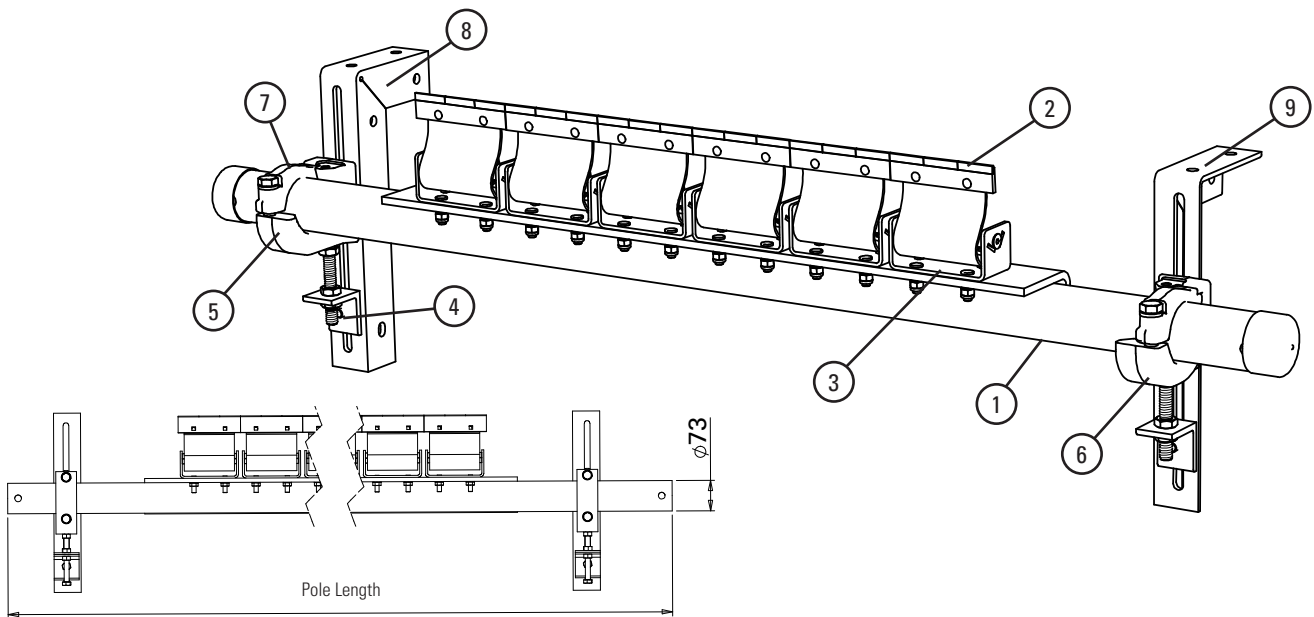

### Replacement Parts

REF	DESCRIPTION		MILD STEEL			STAINLESS STEEL		
	BELT WIDTH	POLE LENGTH	ORDERING NUMBER	ITEM CODE	WT. KG	ORDERING NUMBER	ITEM CODE	WT. KG
	mm	mm						
1	600	1350	MHS-P600*	77499	21.0	MHS-P600S/S*	77508	21.5
	750	1500	MHS-P750*	77500	23.5	MHS-P750S/S*	77509	24.0
	900	1650	MHS-P900*	77501	26.0	MHS-P900S/S*	77510	26.5
	1050	1800	MHS-P1050*	77502	28.5	MHS-P1050S/S*	77511	29.0
	1200	1950	MHS-P1200*	77527	31.0	MHS-P1200S/S*	77528	31.8
	1350	2100	MHS-P1350*	77503	33.5	MHS-P1350S/S*	77512	34.3
	1500	2350	MHS-P1500*	77504	36.0	MHS-P1500S/S*	77513	36.8
	1800	2650	MHS-P1800*	77505	38.5	MHS-P1800S/S*	77514	39.3
	2100	3200	MHS-P2100*	77506	43.5	MHS-P2100S/S*	77515	44.5
	2400	3250	MHS-P2400*	77507	51.0	MHS-P2400S/S*	77516	52.0
2	R - V-Tip (for vulcanised belts only)		RSA150	73628	0.4	RVT6-S/S 76205 0.4		
	Extra Life R - V-Tip (15mm) (for vulcanised belts only)		RSA150-EL15	61141	0.4			
	Extra Life R - V-Tip (20mm) (for vulcanised belts only)		RSA150-XL	67776	0.7			
	C-Tip (for mechanically spliced and vulcanised belts)		ICT6	74535	0.4			
-	Poly Tip Kit		PTK	65746	0.5	PTK	65746	0.5
3	PowerFlex™ Cushion		SPFC	79200	2.0	SPFC-S/S	79201	2.0
4	Adjusting Bracket Kit* (1ea.)		PAB	75513	0.7	PAB-S/S	75515	0.7
5	HD Pole Clamp Kit Left* (1ea.) (incl. item 9a) (for sizes 1200–2400mm)		CCKHDL	79225	4.0	CCKHDL-S/S	79227	4.0
6	HD Pole Clamp Kit Right* (1ea.) (incl. item 9a) (for sizes 1200–2400mm)		CCKHDR	79229	4.0	CCKHDR-S/S	79231	4.0
7	HD Cradle Clamp Top Strap (1ea.) (for use on L or R HD Pole Clamp Kit)		CCKHDTs	79233	0.8	CCKHDTs-S/S	73235	0.8
8	Mounting Bracket Kit Left		PMBL	75516	3.8	PMBL-S/S	75518	3.8
9	Mounting Bracket Kit Right		PMBR	75519	3.8	PMBR-S/S	75521	3.8
-	HD Cradle Clamp Mounting Kit* (for sizes 1200–2400mm) (incl. 2 ea. item 4, and 1 ea. items 5, 6, 8 & 9)		CCMKHD	78920	16.7	CCMKHD-S/S	78922	16.7

\*Lead time: 3 weeks

Stock items (non-shaded) refer to (\*) for specific lead time, if not specified, standard lead time applies.  
Non-stock items (shaded) please contact Flexco for dispatch options and lead times.

# Product Ordering Information

## MHS - SST Heavy Duty Secondary Cleaner

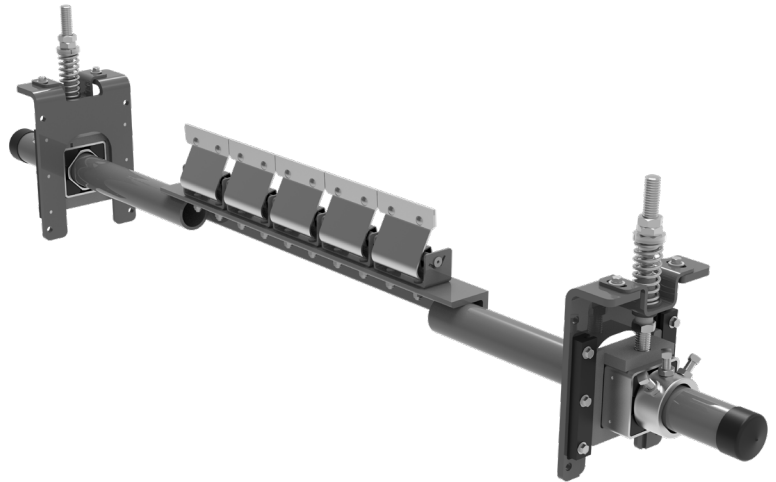

### MHS HD with SST Tensioner (Complete MHS-FP Cleaner-V Tips)

BELT WIDTH	TIP WIDTH	POLE LENGTH	MILD STEEL			STAINLESS STEEL		
			ORDERING NUMBER	ITEM CODE	WT. KG	ORDERING NUMBER	ITEM CODE	WT. KG
600	600	1350	MHS-600FPV	77789	56.8	MHS-600FPV-S/S	77799	58.0
750	750	1500	MHS-750FPV	77790	61.8	MHS-750FPV-S/S	77800	63.0
900	900	1650	MHS-900FPV	77791	67.0	MHS-900FPV-S/S	77801	68.3
1050	1050	1800	MHS-1050FPV	77792	71.8	MHS-1050FPV-S/S	77802	73.3
1200	1200	1950	MHS-1200FPV	77793	76.8	MHS-1200FPV-S/S	77803	78.3
1350	1350	2100	MHS-1350FPV	77794	81.5	MHS-1350FPV-S/S	77804	83.3
1500	1500	2350	MHS-1500FPV	77795	86.5	MHS-1500FPV-S/S	77805	88.3
1800	1800	2650	MHS-1800FPV	77796	96.5	MHS-1800FPV-S/S	77806	98.5
2100	2100	3200	MHS-2100FPV	77797	108.5	MHS-2100FPV-S/S	77807	110.8
2400	2400	3250	MHS-2400FPV	77798	125.0	MHS-2400FPV-S/S	77808	127.0

Lead time: 3 weeks

### Tips Required Per Cleaner Size

mm	450	600	750	900	1050	1200	1350	1500	1800
No. C-Tips or V-Tips Required	3	4	5	6	7	8	9	10	12

Stock items (non-shaded) refer to (\*) for specific lead time, if not specified, standard lead time applies.

Non-stock items (shaded) please contact Flexco for dispatch options and lead times.

# Replacement Parts List

## MHS - SST Heavy Duty Secondary Cleaner

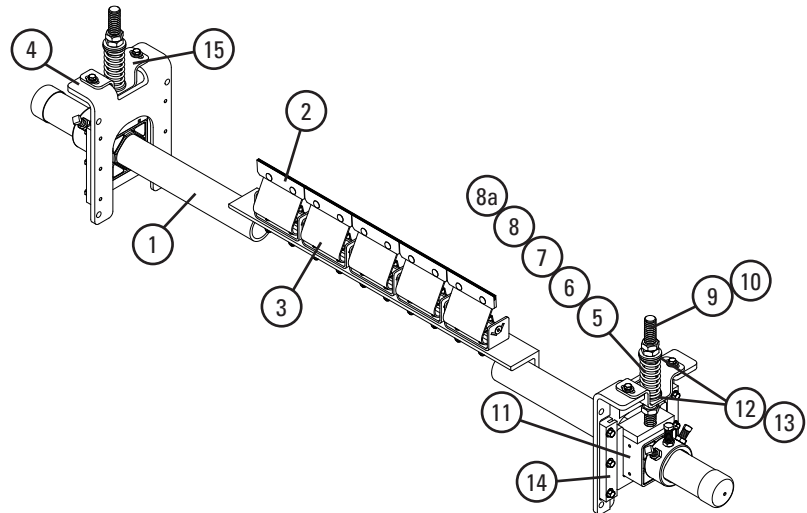

### Replacement Parts

REF	DESCRIPTION		MILD STEEL			STAINLESS STEEL		
	BELT WIDTH	POLE LENGTH	ORDERING NUMBER	ITEM CODE	WT. KG	ORDERING NUMBER	ITEM CODE	WT. KG
	mm	mm						
1	600	1350	MHS-P600*	77499	23.5	MHS-P600S/S*	77508	24.0
	750	1500	MHS-P750*	77500	26.0	MHS-P750S/S*	77509	26.5
	900	1650	MHS-P900*	77501	28.5	MHS-P900S/S*	77510	29.0
	1050	1800	MHS-P1050*	77502	31.0	MHS-P1050S/S*	77511	31.7
	1200	1950	MHS-P1200*	77527	33.5	MHS-P1200S/S*	77528	34.3
	1350	2100	MHS-P1350*	77503	36.0	MHS-P1350S/S*	77512	36.8
	1500	2350	MHS-P1500*	77504	38.5	MHS-P1500S/S*	77513	39.3
	1800	2650	MHS-P1800*	77505	43.5	MHS-P1800S/S*	77514	44.4
	2100	3200	MHS-P2100*	77506	51.0	MHS-P2100S/S*	77515	52.0
	2400	3250	MHS-P2400*	77507	58.0	MHS-P2400S/S*	77516	59.3
2	R - V-Tip (for vulcanised belts only)		RSA150	73628	0.4	RVT6-S/S	76205	0.4
	Extra Life R - V-Tip (15mm) (for vulcanised belts only)		RSA150-EL15	61141	0.4			
	Extra Life R - V-Tip (20mm) (for vulcanised belts only)		RSA150-XL	67776	0.7			
	C-Tip (for mechanically spliced and vulcanised belts)		ICT6	74535	0.4			
-	Poly Tip Kit		PTK	65746	0.5	PTK	65746	0.5
3	PowerFlex™ Cushion		SPFC	79200	2.0	SPFC-S/S	79201	2.0
4	SST Mounting Base Kit* (includes 1 mounting base, 2 slide guides, top hat bracket & bottom bushing)		SSTXDMK	91412	4.6	STHDMK2-S/S	77634	4.6
5	Tension Spring - White (1 ea.) for belts 450–750mm		STS-W	75846	0.2	STS-W-S/S	77630	0.2
6	Tension Spring - Silver (1 ea.) for belts 900–1500mm		STS-S	75843	0.4	STS-S-S/S	77631	0.4
7	Tension Spring - Black (1 ea.) for belts 1800–2100mm		STS-B	75844	0.5	STS-B-S/S	77632	0.5
8	Tension Spring - Gold (1 ea.) for belts over 2100mm		STS-G	78142	0.7	STS-G-S/S	79057	0.5
9	SST Adj Rod Kit* (incl. 1 rod, 2 nuts, 2 bushings, 1 washer) for belts 450–1500 mm		STAK	75847	1.3	STAK	75847	1.3
10	SST HD Adj Rod Kit* (incl. 1 rod, 2 nuts, 2 HD bushings, 1 washer) for belts 1800–2100mm		STAKHD	75892	1.4	STAKHD	75892	1.4
11	SST HD Torsion Pole Mount* (1 ea.)		SSTHDPM	77868	6.8	STHDPM2-S/S	77633	6.8
12	SST Bushing Kit - White/Silver		SSTBK-W	76636	0.1	SSTBK-W	76636	0.1
13	SST Bushing Kit - Black/Gold		SSTBK-B	76637	0.1	SSTBK-B	76637	0.1
14	ST Slide Guide Kit		STGK2	77635	0.5	STGK2	77635	0.5
-	SST HD Cartridge Tensioner - White (includes 1 ea. item 5, 9, 12, 14) for belts 450–750mm		SST1HDM-W	78517	13.7	SST1HDM-W-S/S	78394	13.7
-	SST HD Cartridge Tensioner - Silver (includes 1 ea. item 6, 9, 12, 14) for belts 900–1500mm		SST1HDM-S	78518	13.9	SST1HDM-S-S/S	78395	13.9
-	SST HD Cartridge Tensioner - Black (includes 1 ea. item 7, 10, 13, 14) for belts 1800–2100mm		SST1HDM-B	78519	14.1	SST1HDM-B-S/S	78396	14.1
-	SST HD Cartridge Tensioner - Gold (includes 1 ea. item 8, 10, 13, 14) for belts over 2100mm		SST1HDM-G	79069	14.3	SST1HDM-G-S/S	79454	14.3
15	SST Hat Channel Kit		SSTHK	79582	0.7	SSTHK-S/S	78586	0.7

\*Lead time: 3 weeks

  Stock items (non-shaded) refer to (\*) for specific lead time, if not specified, standard lead time applies.

  Non-stock items (shaded) please contact Flexco for dispatch options and lead times.

# Replacement Parts List

## MHS - MST Heavy Duty Secondary Cleaner

### Primary Replacement Parts

DESCRIPTION	ORDERING NUMBER	ITEM CODE	WT. KG
Primary Air Tension 60mm Complete Kit*	ATVKP-60	63861	15.2
Primary Air Tension 73mm Complete Kit*	ATVKP-73	63862	16.6
Air Tank Kit with PAT & Control Box 100psi**	ATV73-SS	66192	35.0

\*includes 1 each: Mounting brackets, air bag, adjusting arm and hardware  
 \*\*includes 1 each of 63862, 65803, 65571 & 66068

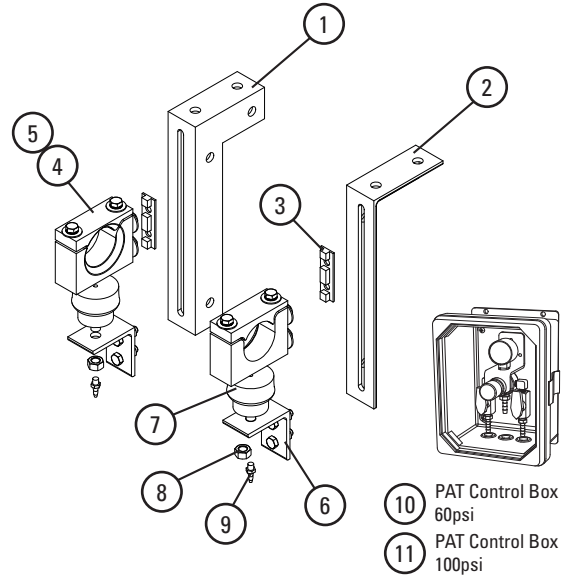

### Secondary Replacement Parts

REF	DESCRIPTION	ORDERING NUMBER	ITEM CODE	WT. KG
1	Mounting Bracket LH	PMBL-S/S	75518	3.8
2	Mounting Bracket RH	PMBR-S/S	75521	3.8
3	Air Tensioner Slider	ATV-SLIDE	62425	0.2
4	Air Tension Cradle Blocks 60mm Kit	ATV-MOUNT	62424	2.4
5	Air Tension Cradle Blocks 73mm Kit	ATV-MOUNT	63073	2.4
6	Air Tension Adjusting Angle	ATV-ANGLE	62426	1.0
-	Secondary Air Tension 60mm Complete Kit*	ATVK-60	62409	13.0
-	Secondary Air Tension 73mm Complete Kit*	ATVK-73	63072	15.0
-	Air Tank Kit with PAT & Control Box 100psi**	ATVK73-SEC-SS	64743	33.0

\*includes 2 each: mounting brackets, air tension slider, cradle kit, adjusting angle, air bag and hardware  
 \*\*includes 1 each of 63072, 65803, 65571 & 66068

### Common Replacement Parts

REF	DESCRIPTION	ORDERING NUMBER	ITEM CODE	WT. KG
-	PAT 10MM Black Nylon Tube 20M	ATV-TUBE	66068	0.1
7	Air Bag	ATV-BAG	62079	0.2
8	Hex Nut S/S	HEX NUT	G1211	0.1
9	Air Line Adaptor	ATV-NIP	62037	0.1
10	PAT Control Box 60psi	PACB60	66055	5.0
11	PAT Control Box 100psi	PACB100	65803	5.0
-	PAT1 Tank	PAT1	65571	10.0

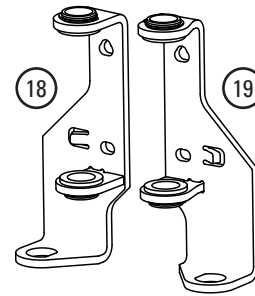

### MST Tensioner Replacement Parts

REF	DESCRIPTION	ORDERING NUMBER	ITEM CODE	WT. KG	STAINLESS STEEL		
					ORDERING NUMBER	ITEM CODE	WT. KG
18	MST Mounting Bracket LH (incl. bushings)	MST-MBL	79436	2.6			
19	MST Mounting Bracket RH (incl. bushings)	MST-MBR	79437	2.6			
-	MST Retrofit Kit	MST-PMBLR	64564	2.0	MST-PMBLR-SS	64565	2.0
20	MST Drop Brackets (2)	MSTDB	79434	12.6	MSTDB-S/S	65865	12.6
-	MST HD Tensioner w/White Spring	MSTHD-W	79431	16.7	MSTHD-SS-W	90181	16.7
-	MST HD Tensioner w/Silver Spring	MSTHD-S	79432	17.0	MSTHD-SS-S	90182	17.0
-	MST HD Tensioner w/Black Spring	MSTHD-B	79433	17.3	MSTHD-SS-B	90183	17.3
-	MST HD Tensioner w/Gold Spring	MSTHD-G	63020	17.3	MSTHD-SS-G	90184	17.3

Shaded items are made to order. Lead time 3 weeks.

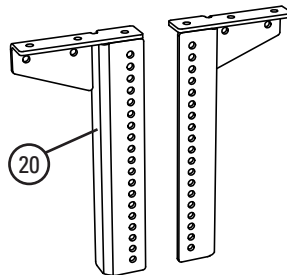

Stock items (non-shaded) refer to (\*) for specific lead time, if not specified, standard lead time applies.  
 Non-stock items (shaded) please contact Flexco for dispatch options and lead times.

# Specifications & Guidelines

## MHS - SST Heavy Duty Secondary Cleaner

### Clearance Guidelines for Installation

HORIZONTAL CLEARANCE REQUIRED	VERTICAL CLEARANCE REQUIRED
mm	mm
100	238

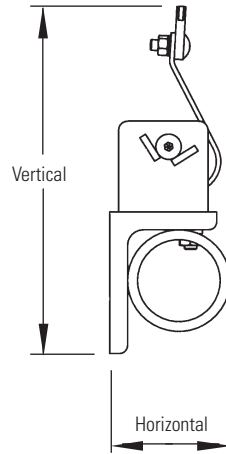

### SST Spring Length Chart

Blade Width	White Springs	Silver Springs	Black Springs	Gold Springs
mm	mm	mm	mm	mm
450	86	102	N/A	N/A
600	79	98	N/A	N/A
750	73	95	N/A	N/A
900	N/A	95	98	N/A
1050	N/A	92	95	N/A
1200	N/A	89	92	N/A
1350	N/A	86	92	95
1500	N/A	83	89	95
1800	N/A	N/A	86	92
2100	N/A	N/A	79	89
2400	N/A	N/A	N/A	86

Shading indicates preferred spring option.

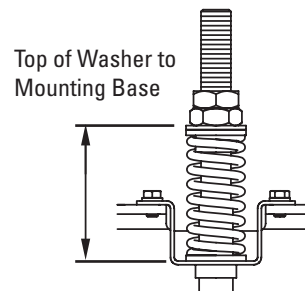

### Specifications:

- Maximum Belt Speed .....Contact Flexco
- Temperature Rating .....-35 to 82°C
- Usable Blade Wear Length.....9 mm
- Blade Materials .....C-Tip: Impact Resistant Tungsten Carbide (works with mechanical fasteners)  
V-Tip: Long Life Tungsten Carbide (for vulcanised belts only)

# Product Ordering Information

## Spring Covers and Tensioner Lock

### Spring Covers

ORDERING NUMBER	ITEM CODE	WT. KG
SPG-CVR-A	77387	0.14
SPG-CVR-B	77388	0.14
SPG-CVR-C	77389	0.14
SPG-CVR-D	77390	0.18
SPG-CVR-E	77391	0.18
SPG-CVR-F	77392	0.14
SPG-CVR-G	77393	0.14
SPG-CVR-H	77741	0.14

Includes 1 spring cover

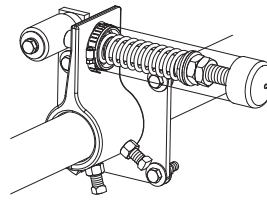
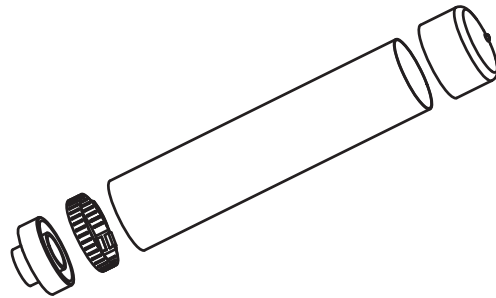

Spring cover on Primary Cleaner tensioner

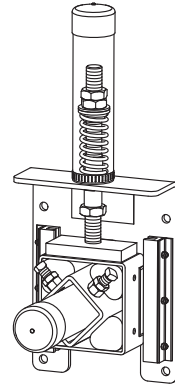

Spring cover on Secondary cleaner tensioner

### Tensioner Lock

Designed to prevent tampering or unauthorized retensioning of the cleaner.

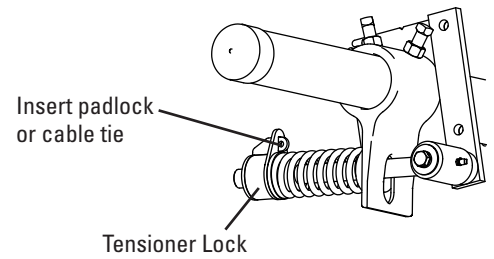
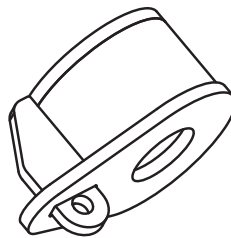

ORDERING NUMBER	ITEM CODE	WT. KG
TEN-LOCK-KIT	77443	0.18

\*For MSP, MMP, MHP, MHCP, H-Type® Primary Cleaner and MSS, MHS, MDWS Secondary Cleaners  
Includes 1 tensioner lock



Tensioner Lock

(Primary Cleaner tensioner shown)

 **Stock items** (non-shaded) refer to (\*) for specific lead time, if not specified, standard lead time applies.  
 **Non-stock items** (shaded) please contact Flexco for dispatch options and lead times.



# Product Ordering Information

## P-Type® SAC Secondary Cleaner with Service Advantage Cartridge™

### P-Type® SAC Secondary with V-Tips\*

BELT WIDTH	ORDERING NUMBER	ITEM CODE	WT. KG
mm			
600	PV600-SAC	78020	62.3
750	PV750-SAC	78021	68.4
900	PV900-SAC	78022	74.4
1050	PV1050-SAC	78023	80.4
1200	PV1200-SAC	78024	86.4
1350	PV1350-SAC	78025	92.5
1500	PV1500-SAC	78026	98.5
1800	PV1800-SAC	78027	110.6
1500	PV1500-2SAC	78028	137.8
1800	PV1800-2SAC	78029	150.0
2100	PV2100-2SAC	78030	162.5
2400	PV2400-2SAC	78031	174.7
3000	PV3000-2SAC	78032	201.3

\*NOTE: V-Tips can be used ONLY on vulcanised belts.

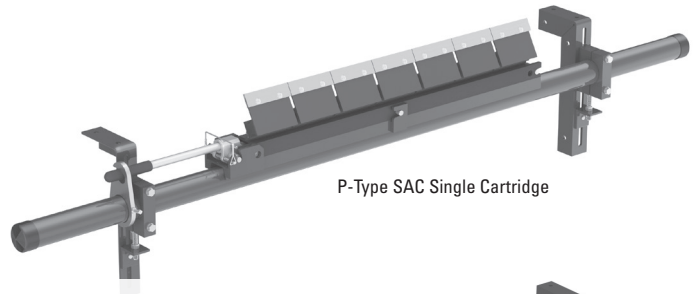

P-Type SAC Single Cartridge

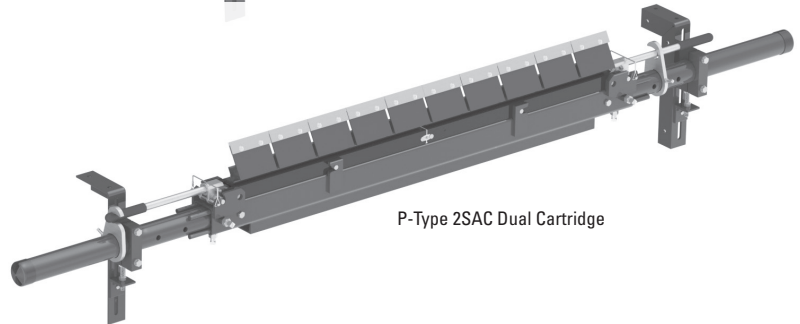

P-Type 2SAC Dual Cartridge

### P-Type SAC Stainless Steel Secondary with V-Tips\*

BELT WIDTH	ORDERING NUMBER	ITEM CODE	WT. KG
mm			
600	PV600-SAC-S/S	78329	62.3
750	PV750-SAC-S/S	78330	68.4
900	PV900-SAC-S/S	78331	74.4
1050	PV1050-SAC-S/S	78332	80.4
1200	PV1200-SAC-S/S	78333	86.4
1350	PV1350-SAC-S/S	78334	92.5
1500	PV1500-SAC-S/S	78335	98.5
1800	PV1800-SAC-S/S	78336	110.6
1500	PV1500-2SAC-S/S	78337	137.8
1800	PV1800-2SAC-S/S	78338	150.0
1950	PV1950-2SAC-S/S	78656	156.2
2100	PV2100-2SAC-S/S	78339	162.5
2400	PV2400-2SAC-S/S	78340	174.7
3000	PV3000-2SAC-S/S	78341	201.3

\*NOTE: V-Tips can be used ONLY on vulcanised belts.

### Replacement Tips

ORDERING NUMBER	ITEM CODE	WT. KG
ICT6 (C-Tip)	74535	0.4
PSA150 (V-Tip)	73156	0.4

### Tips Required Per Cleaner Size

BELT WIDTH	BLADE COVERAGE	No. V-TIPS REQUIRED
mm	mm	
600	600	4
750	750	5
900	900	6
1050	1050	7
1200	1200	8
1350	1350	9
1500	1500	10
1800	1800	12
2100	2100	14
2400	2400	16
3000	3000	20

### Product Notes:

- Patented Service Advantage Cartridge™ allows for easy removal in even the dirtiest conditions.
- Pole Length: Belt width plus 1350 mm (single cartridge cleaners); Belt width plus 1500 mm (dual cartridge cleaners).
- Tips are set at a non-aggressive 70° angle to give quick relief for passing mechanical splices.
- Tensioner mounting brackets included for fast and easy installation.
- Cartridge Removal Kit included for easy removal of the cartridge.

Stock items (non-shaded) refer to (\*) for specific lead time, if not specified, standard lead time applies.  
Non-stock items (shaded) please contact Flexco for dispatch options and lead times.

# Product Ordering Information

**P-Type® SAC**  
**Secondary Cleaner**  
*with Service Advantage Cartridge™*

## P-Type® SAC Cartridge Kits with V-Tips\*

BELT WIDTH	ORDERING NUMBER	ITEM CODE	WT. KG
mm			
600	P-CARK-V24/600	78080	11.4
750	P-CARK-V30/750	78081	13.6
900	P-CARK-V36/900	78082	15.7
1050	P-CARK-V42/1050	78083	17.9
1200	P-CARK-V48/1200	78084	20.0
1350	P-CARK-V54/1350	78085	22.2
1500	P-CARK-V60/1500	78086	24.4
1800	P-CARK-V72/1800	78087	28.7
1500	P-CARK2-V60/1500	78093	39.7
1800	P-CARK2-V72/1800	78094	46.4
2100	P-CARK2-V84/2100	78095	53.2
2400	P-CARK2-V96/2400	78096	59.9
3000	P-CARK2-V120/3000	78097	73.6

\*NOTE: V-Tips can be used ONLY on vulcanised belts.

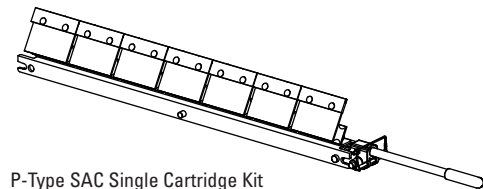

P-Type SAC Single Cartridge Kit

## P-Type SAC Stainless Steel Cartridge Kits with V-Tips\*

BELT WIDTH	ORDERING NUMBER	ITEM CODE	WT. KG
mm			
600	P-CARK-V24/600-S/S PVECKS/S	82815	11.4
750	P-CARK-V30/750-S/S PVECKS/S	82816	13.6
900	P-CARK-V36/900-S/S PVECKS/S	82817	15.7
1050	P-CARK-V42/1050-S/S PVECKS/S	82818	17.9
1200	P-CARK-V48/1200-S/S PVECKS/S	82819	20.0
1350	P-CARK-V54/1350-S/S PVECKS/S	82820	22.2
1500	P-CARK-V60/1500-S/S PVECKS/S	82821	24.4
1800	P-CARK-V72/1800-S/S PVECKS/S	82822	28.7
1500	P-CARK2-V60/1500-S/S PV2ECKSS	82823	39.7
1800	P-CARK2-V72/1800-S/S PV2ECKSS	82824	46.4
2000	P-CARK2-V78/1950-S/S PV2ECKSS	82876	49.2
2100	P-CARK2-V84/2100-S/S PV2ECKSS	82825	53.2
2400	P-CARK2-V96/2400-S/S PV2ECKSS	82826	59.9
3000	P-CARK2-V120/3000-S/S PV2ECKSS	82827	73.6

\*NOTE: V-Tips can be used ONLY on vulcanised belts.

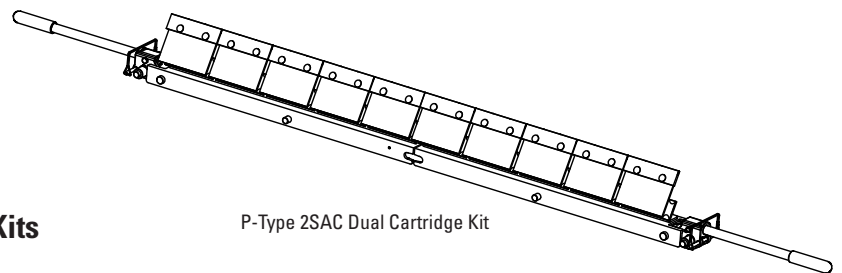

P-Type 2SAC Dual Cartridge Kit

Stock items (non-shaded) refer to (\*) for specific lead time, if not specified, standard lead time applies.  
 Non-stock items (shaded) please contact Flexco for dispatch options and lead times.

# Replacement Parts List

## P-Type® SAC (Mild Steel) Secondary Cleaner with Service Advantage Cartridge™

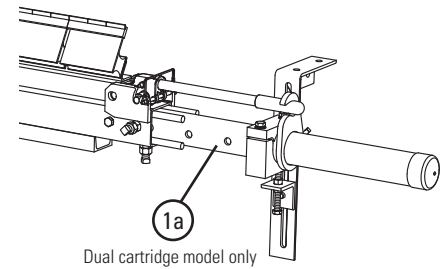
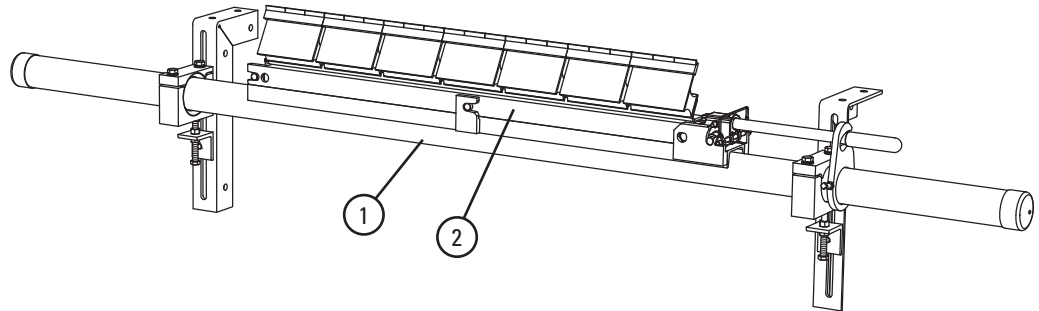

### Replacement Parts

REF	DESCRIPTION	ORDERING NUMBER	ITEM CODE	WT. KG
1	SAC Cartridge Pole 600mm	SACPL-24/600	77887	29.7
	SAC Cartridge Pole 750mm	SACPL-30/750	77888	32.3
	SAC Cartridge Pole 900mm	SACPL-36/900	77889	35.0
	SAC Cartridge Pole 1050mm	SACPL-42/1050	77890	37.6
	SAC Cartridge Pole 1200mm	SACPL-48/1200	77891	40.3
	SAC Cartridge Pole 1350mm	SACPL-54/1350	77892	42.9
	SAC Cartridge Pole 1500mm	SACPL-60/1500	77893	45.6
	SAC Cartridge Pole 1800mm	SACPL-72/1800	77894	50.9
	SAC Cartridge Center Pole 1500mm (Dual)	SACPL2-60/1500	77895	35.1
	SAC Cartridge Center Pole 1800mm (Dual)	SACPL2-72/1800	77896	40.6
	SAC Cartridge Center Pole 2100mm (Dual)	SACPL2-84/2100	77897	46.2
	SAC Cartridge Center Pole 2400mm (Dual)	SACPL2-96/2400	77898	51.8
	SAC Cartridge Center Pole 3000mm (Dual)	SACPL2-120/3000	77899	64.5
	1a	Extender Pole (for use with Dual Cartridge Center Pole)	MHP-EP	76392
2	SAC Repl Cartridge S/S 600mm	CART-24/600-S/S	78576	4.5
	SAC Repl Cartridge S/S 750mm	CART-30/750-S/S	78577	5.6
	SAC Repl Cartridge S/S 900mm	CART-36/900-S/S	78578	6.7
	SAC Repl Cartridge S/S 1050mm	CART-42/1050-S/S	78579	7.8
	SAC Repl Cartridge S/S 1200mm	CART-48/1200-S/S	78580	8.9
	SAC Repl Cartridge S/S 1350mm	CART-54/1350-S/S	78581	10.0
	SAC Repl Cartridge S/S 1500mm	CART-60/1500-S/S	78582	11.3
	SAC Repl Cartridge S/S 1800mm	CART-72/1800-S/S	78583	13.5
	SAC Repl Cartridge S/S 1500mm (Dual)	CART2-60/1500-S/S	78584	11.2
	SAC Repl Cartridge S/S 1800mm (Dual)	CART2-72/1800-S/S	78585	13.4
	SAC Repl Cartridge S/S 1950mm (Dual)	CART2-78/1950-S/S	78635	14.5
	SAC Repl Cartridge S/S 2100mm (Dual)	CART2-84/2100-S/S	78586	15.6
	SAC Repl Cartridge S/S 2400mm (Dual)	CART2-96/2400-S/S	78587	17.8
	SAC Repl Cartridge S/S 3000mm (Dual)	CART2-120/3000-S/S	78588	22.6

**Stock items** (non-shaded) refer to (\*) for specific lead time, if not specified, standard lead time applies.

**Non-stock items** (shaded) please contact Flexco for dispatch options and lead times.

# Replacement Parts List

## P-Type® SAC (Mild Steel) Secondary Cleaner with Service Advantage Cartridge™

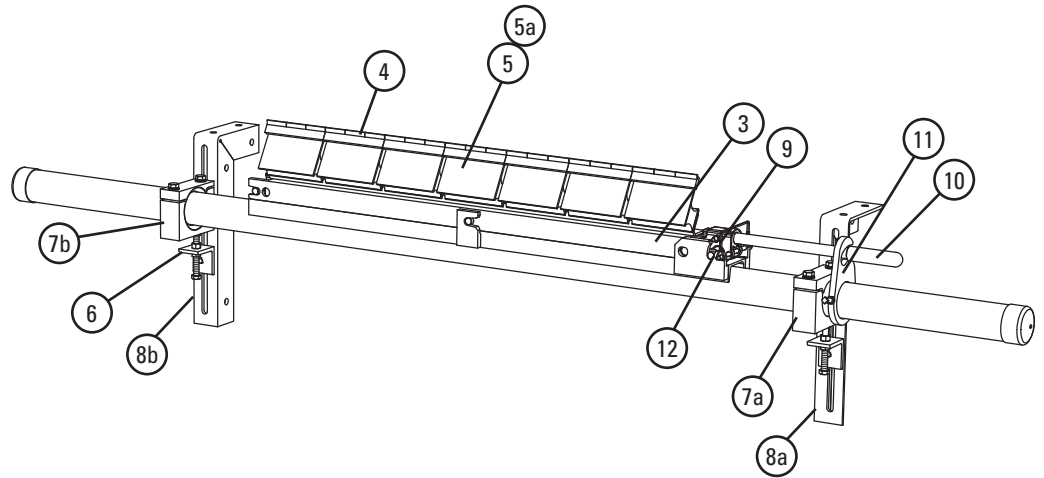

### Replacement Parts (Continued)

REF	DESCRIPTION	ORDERING NUMBER	ITEM CODE	WT. KG
3	SAC Cartridge P-Type® Adapter Plate 600mm	PCAP-24/600	77913	2.1
	SAC Cartridge P-Type Adapter Plate 750mm§	PCAP-30/750	77914	2.8
	SAC Cartridge P-Type Adapter Plate 900mm§	PCAP-36/900	77915	3.3
	SAC Cartridge P-Type Adapter Plate 1050mm§	PCAP-42/1050	77916	3.9
	SAC Cartridge P-Type Adapter Plate 1200mm§	PCAP-48/1200	77917	4.4
	SAC Cartridge P-Type Adapter Plate 1350mm	PCAP-54/1350	77918	5.0
	SAC Cartridge P-Type Adapter Plate 1500mm§	PCAP-60/1500	77919	5.6
	SAC Cartridge P-Type Adapter Plate 1800mm	PCAP-72/1800	77920	6.7
4	P V-Tip* (for vulcanised belts only)	PSA150	73156	0.4
	Extra Life P - V-Tip (15mm) (for vulcanised belts only)	PSA150-EL15	62094	0.4
	Extra Life P - V-Tip (20mm) (for vulcanised belts only)	PSA150-XL	67777	0.7
	C-Tip*	ICT6	74535	0.4
5	Cushion*	PHA	73626	1.6
5a	HD P-Type Cushion	HDPHC	61003	1.0
6	P/R Adjusting Bracket	PAB	75513	0.4
7a	Cradle Clamp Block RH	SMR-CCB-R73	A2843	1.2
7b	Cradle Clamp Block LH	SMR-CCB-L73	A2842	1.2
8a	Mounting Bracket Kit, RH	PMBR	75519	3.8
8b	Mounting Bracket Kit, LH	PMBL	75516	3.8
9	SAC Removal Knuckle	SACRKN	77882	1.5
10	SAC Removal Handle	SACRH	77883	1.4
11	SAC Handle Lock Plate	SACRHL	77884	0.8
12	Knuckle Retainer Pin	SACKRP	77885	0.1
-	SAC Removal Kit (includes 1 ea. items 9,10,11,12)	SACRKT	77886	4.1
13	SAC Cartridge Tip Alignment Tool (Dual)	SAC2-TIP-TL	77866	1.1
-	Cradle Clamp Heavy-Duty Mounting Kit (incl. 2 ea. item 6; incl. 1 ea. items 7a, 7b, 8a, 8b)	CRHMK	62400	10.8

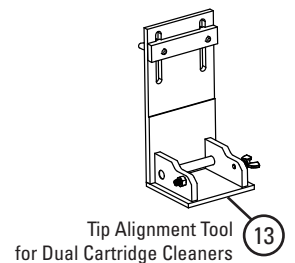

§ If using a dual cartridge, please take the cleaner size and divide by two. That dimension is the size of the brackets needed for conversion to a P-Type cleaner.

Stock items (non-shaded) refer to (\*) for specific lead time, if not specified, standard lead time applies.  
Non-stock items (shaded) please contact Flexco for dispatch options and lead times.

# Replacement Parts List

## P-Type® SAC (Stainless Steel) Secondary Cleaner with Service Advantage Cartridge™

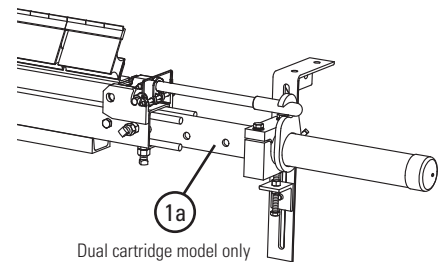
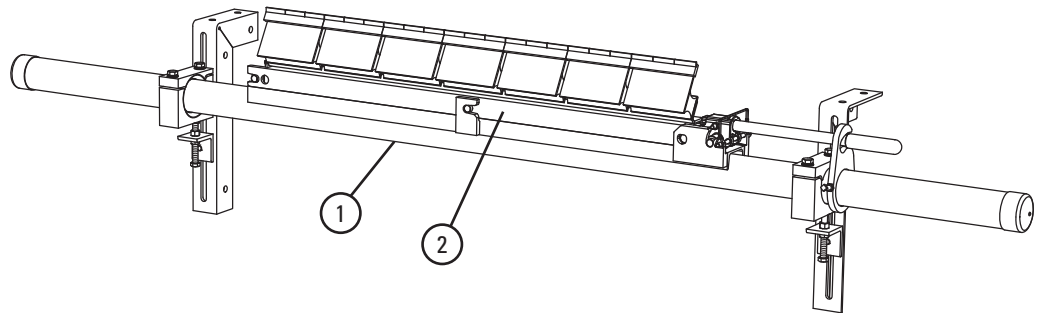

### Replacement Parts

REF	DESCRIPTION	ORDERING NUMBER	ITEM CODE	WT. KG
1	SAC S/S Cartridge Pole 600mm	SACPL-24/600-S/S	78371	29.7
	SAC S/S Cartridge Pole 750mm	SACPL-30/750-S/S	78372	32.3
	SAC S/S Cartridge Pole 900mm	SACPL-36/900-S/S	78373	35.0
	SAC S/S Cartridge Pole 1050mm	SACPL-42/1050-S/S	78374	37.6
	SAC S/S Cartridge Pole 1200mm	SACPL-48/1200-S/S	78375	40.3
	SAC S/S Cartridge Pole 1350mm	SACPL-54/1350-S/S	78376	42.9
	SAC S/S Cartridge Pole 1500mm	SACPL-60/1500-S/S	78377	45.6
	SAC S/S Cartridge Pole 1800mm	SACPL-72/1800-S/S	78378	50.9
	SAC S/S Cartridge Center Pole 1500mm (Dual)	SACPL2-60/1500-S/S	78379	35.1
	SAC S/S Cartridge Center Pole 1800mm (Dual)	SACPL2-72/1800-S/S	78380	40.6
	SAC S/S Cartridge Center Pole 1950mm (Dual)	SACPL2-78/1950-S/S	78642	43.9
	SAC S/S Cartridge Center Pole 2100mm (Dual)	SACPL2-84/2100-S/S	78381	46.2
	SAC S/S Cartridge Center Pole 2400mm (Dual)	SACPL2-96/2400-S/S	78382	51.8
	SAC S/S Cartridge Center Pole 3000mm (Dual)	SACPL2-120/3000-S/S	78383	64.5
1a	S/S Extender Pole (for use with S/S Dual Cartridge Center Pole)	MHP-EP-S/S	77599	24.5
2	SAC Repl Cartridge S/S 600mm	CART-24/600-S/S	78576	4.5
	SAC Repl Cartridge S/S 750mm	CART-30/750-S/S	78577	5.6
	SAC Repl Cartridge S/S 900mm	CART-36/900-S/S	78578	6.7
	SAC Repl Cartridge S/S 1050mm	CART-42/1050-S/S	78579	7.8
	SAC Repl Cartridge S/S 1200mm	CART-48/1200-S/S	78580	8.9
	SAC Repl Cartridge S/S 1350mm	CART-54/1350-S/S	78581	10.0
	SAC Repl Cartridge S/S 1500mm	CART-60/1500-S/S	78582	11.3
	SAC Repl Cartridge S/S 1800mm	CART-72/1800-S/S	78583	13.5
	SAC Repl Cartridge S/S 1500mm (Dual)	CART2-60/1500-S/S	78584	11.2
	SAC Repl Cartridge S/S 1800mm (Dual)	CART2-72/1800-S/S	78585	13.4
	SAC Repl Cartridge S/S 1950mm (Dual)	CART2-78/1950-S/S	78635	14.5
	SAC Repl Cartridge S/S 2100mm (Dual)	CART2-84/2100-S/S	78586	15.6
	SAC Repl Cartridge S/S 2400mm (Dual)	CART2-96/2400-S/S	78587	17.8
	SAC Repl Cartridge S/S 3000mm (Dual)	CART2-120/3000-S/S	78588	22.6

Stock items (non-shaded) refer to (\*) for specific lead time, if not specified, standard lead time applies.  
 Non-stock items (shaded) please contact Flexco for dispatch options and lead times.

# Replacement Parts List

## P-Type® SAC (Stainless Steel) Secondary Cleaner with Service Advantage Cartridge™

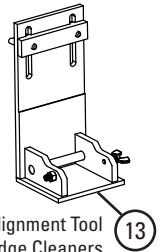
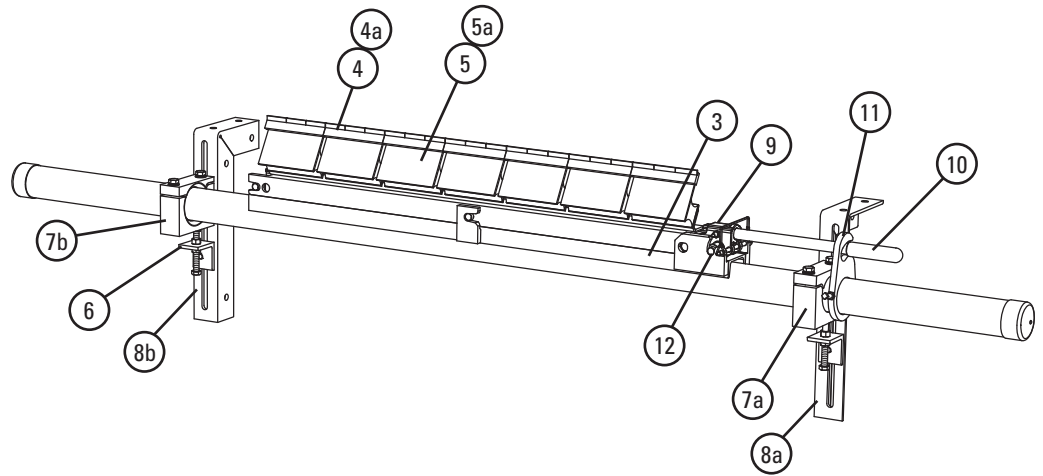

### Replacement Parts (Continued)

REF	DESCRIPTION	ORDERING NUMBER	ITEM CODE	WT. KG
3	SAC Cartridge P-Type® S/S Adapter Plate 600mm	PCAP-24/600-S/S	78355	2.1
	SAC Cartridge P-Type S/S Adapter Plate 750mm §	PCAP-30/750-S/S	78356	2.8
	SAC Cartridge P-Type S/S Adapter Plate 900mm §	PCAP-36/900-S/S	78357	3.3
	SAC Cartridge P-Type S/S Adapter Plate 1050mm §	PCAP-42/1050-S/S	78358	3.9
	SAC Cartridge P-Type S/S Adapter Plate 1200mm §	PCAP-48/1200-S/S	78359	4.4
	SAC Cartridge P-Type S/S Adapter Plate 1350mm	PCAP-54/1350-S/S	78360	5.0
	SAC Cartridge P-Type S/S Adapter Plate 1500mm §	PCAP-60/1500-S/S	78361	5.6
	SAC Cartridge P-Type S/S Adapter Plate 1800mm	PCAP-72/1800-S/S	78362	6.7
4	C-Tip	ICT6	74535	0.4
4a	S/S P V-Tip	PVT6-S/S	75420	0.4
5	S/S P Cushion*	PHSC-S/S	73433	1.6
5a	HD P-Type Cushion S/S	HDPHSC-S/S	61001	1.0
6	P/R Adjusting Bracket S/S	PAB-S/S	75515	0.4
7a	Cradle Clamp LH S/S CRDLBLK-LH	CRDLBLK-RH-S/S	A2825	1.2
7b	Cradle Clamp RH S/S CRDLBLK-RH	CRDLBLK-LH-S/S	A2826	1.2
8a	Mounting Bracket Kit RH S/S	PMBR-S/S	75521	3.8
8b	Mounting Bracket Kit LH S/S	PMBL-S/S	75518	3.8
9	SAC Removal Knuckle	SACRKN	77882	1.5
10	SAC Removal Handle S/S	SACRH-S/S	78397	1.4
11	SAC Handle Lock Plate S/S	SACRHL-S/S	78398	0.8
12	Knuckle Retainer Pin S/S	SACKRP-S/S	78399	0.1
-	SAC Removal Kit S/S (includes 1 ea. items 9,10,11,12)	SACRKT-S/S	78401	4.1
13	SAC Cartridge Tip Alignment Tool (Dual)	SAC2-TIP-TL	77866	1.1
-	Cradle Clamp Stainless Steel Heavy-Duty Mounting Kit (incl. 2 ea. item 6; incl. 1 ea. items 7a, 7b, 8a, 8b)	CRHMK-S/S	62095	10.8

§ If using a dual cartridge, please take the cleaner size and divide by two. That dimension is the size of the brackets needed for conversion to a P-Type cleaner.

Stock items (non-shaded) refer to (\*) for specific lead time, if not specified, standard lead time applies.  
 Non-stock items (shaded) please contact Flexco for dispatch options and lead times.



# Specifications & Guidelines

## P-Type<sup>®</sup> SAC Secondary Cleaner with Service Advantage Cartridge<sup>™</sup>

### Pole Length Specifications\*

VERSION	CLEANER SIZE	BLADE WIDTH	POLE LENGTH	MAXIMUM CONVEYOR SPAN
	mm	mm	mm	mm
Single	600	600	1950	1650
	750	750	2100	1800
	900	900	2250	1950
	1050	1050	2400	2100
	1200	1200	2550	2250
	1350	1350	2700	2400
	1500	1500	2850	2550
Dual	1800	1800	3150	2850
	1500	1500	3000	2700
	1800	1800	3300	3000
	2100	2100	3600	3300
	2400	2400	3900	3600
	3000	3000	4500	4200

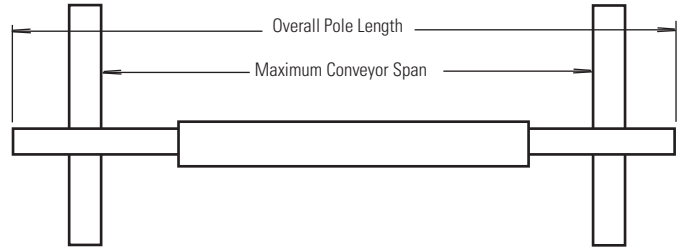

\*For special extra long pole length requirements a Pole Extender Kit (#76024) is available that provides 750mm of extended pole length.  
Pole Diameter - 73mm

### Clearance Guidelines for Installation

VERSION	HORIZONTAL CLEARANCE REQUIRED	VERTICAL CLEARANCE REQUIRED
	mm	mm
Single	114	267
Dual	114	311

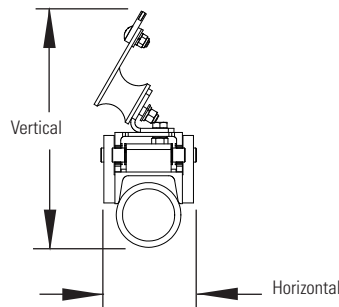

### Specifications:

- Maximum Belt Speed .....5 m/s
- Temperature Rating .....-35 to 82°C
- Usable Blade Wear Length.....9 mm
- Blade Materials .....C-Tip: Impact Resistant Tungsten Carbide (works with mechanical fasteners)  
V-Tip: Long Life Tungsten Carbide (for vulcanised belts only)
- Available for Belt Widths .....600 to 3000 mm. Other sizes available upon request.

# Product Ordering Information

## R-Type® SAC Secondary Cleaner with Service Advantage Cartridge™

### R-Type® SAC Secondary with V-Tips\*

BELT WIDTH	ORDERING NUMBER	ITEM CODE	WT. KG
mm			
600	RV600-SAC	78033	58.3
750	RV750-SAC	78034	63.3
900	RV900-SAC	78035	68.3
1050	RV1050-SAC	78036	73.3
1200	RV1200-SAC	78037	78.3
1350	RV1350-SAC	78038	83.3
1500	RV1500-SAC	78039	88.4
1800	RV1800-SAC	78040	98.3
1500	RV1500-2SAC	78041	107.5
1800	RV1800-2SAC	78042	117.7
2100	RV2100-2SAC	78043	127.8
2400	RV2400-2SAC	78044	138.0
3000	RV3000-2SAC	78045	160.6

\*NOTE: V-Tips can be used ONLY on vulcanised belts.

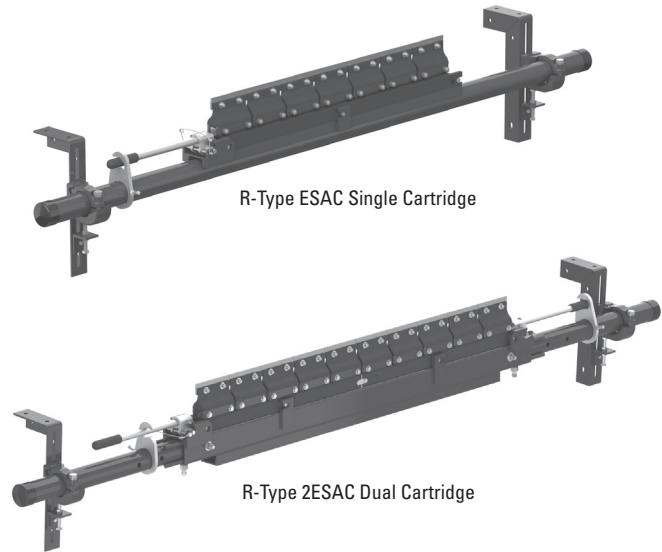

R-Type ESAC Single Cartridge

R-Type 2ESAC Dual Cartridge

### R-Type SAC Stainless Steel Secondary with V-Tips\*

BELT WIDTH	ORDERING NUMBER	ITEM CODE	WT. KG
mm			
600	RV600-SAC-S/S	78342	58.3
750	RV750-SAC-S/S	78343	63.3
900	RV900-SAC-S/S	78344	68.3
1050	RV1050-SAC-S/S	78345	73.3
1200	RV1200-SAC-S/S	78346	78.3
1350	RV1350-SAC-S/S	78347	83.3
1500	RV1500-SAC-S/S	78348	88.4
1800	RV1800-SAC-S/S	78349	98.3
1500	RV1500-2SAC-S/S	78350	107.5
1800	RV1800-2SAC-S/S	78351	117.7
1950	RV1950-2SAC-S/S	78663	122.7
2100	RV2100-2SAC-S/S	78352	127.8
2400	RV2400-2SAC-S/S	78353	138.0
3000	RV3000-2SAC-S/S	78354	160.6

\*NOTE: V-Tips can be used ONLY on vulcanised belts.

### Replacement Tips

ORDERING NUMBER	ITEM CODE	WT. KG
ICT6 (C-Tip)	74535	0.4
RSA150 (V-Tip)	73628	0.4

### Tips Required Per Cleaner Size

BELT WIDTH	BLADE COVERAGE	No. V-TIPS REQUIRED
mm	mm	
600	600	4
750	750	5
900	900	6
1050	1050	7
1200	1200	8
1350	1350	9
1500	1500	10
1800	1800	12
2100	2100	14
2400	2400	16
3000	3000	20

### Product Notes:

- Patented Service Advantage Cartridge™ allows for easy removal in even the dirtiest conditions.
- Pole Length: Belt width plus 1350 mm (single cartridge cleaners); Belt width plus 1500 mm (dual cartridge cleaners).
- Two-way cushions allow cleaning in both directions.
- C-Tips are for mechanically fastened or vulcanised belts. V-Tips are for vulcanised belts only.
- Tensioner mounting brackets included for fast and easy installation.
- Cartridge Removal Kit included for easy removal of the cartridge.

Stock items (non-shaded) refer to (\*) for specific lead time, if not specified, standard lead time applies.  
 Non-stock items (shaded) please contact Flexco for dispatch options and lead times.

# Product Ordering Information

**R-Type® SAC**  
**Secondary Cleaner**  
*with Service Advantage Cartridge™*

## R-Type® SAC Cartridge Kits with V-Tips\*

BELT WIDTH	ORDERING NUMBER	ITEM CODE	WT. KG
mm			
600	R-CARK-V24/600	78106	12.3
750	R-CARK-V30/750	78107	14.7
900	R-CARK-V36/900	78108	16.5
1050	R-CARK-V42/1050	78109	19.3
1200	R-CARK-V48/1200	78110	21.6
1350	R-CARK-V54/1350	78111	24.0
1500	R-CARK-V60/1500	78112	26.4
1800	R-CARK-V72/1800	78113	31.1
1500	R-CARK2-V60/1500	78119	31.6
1800	R-CARK2-V72/1800	78120	33.9
2100	R-CARK2-V84/2100	78121	38.6
2400	R-CARK2-V96/2400	78122	43.3
3000	R-CARK2-V120/3000	78123	52.8

\*NOTE: V-Tips can be used ONLY on vulcanised belts.

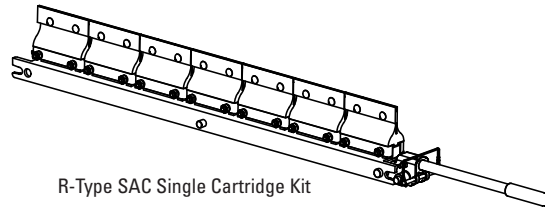

R-Type SAC Single Cartridge Kit

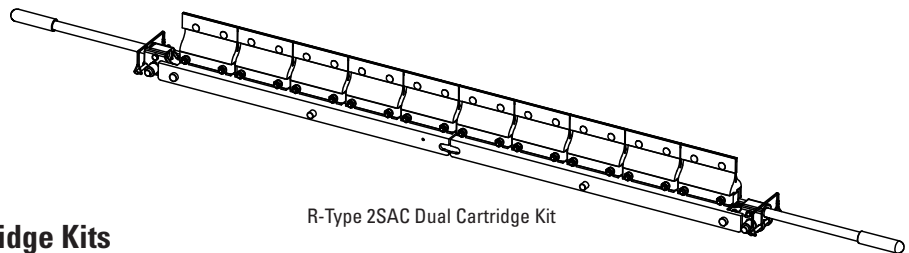

R-Type 2SAC Dual Cartridge Kit

## R-Type SAC Stainless Steel Cartridge Kits with V-Tips\*

BELT WIDTH	ORDERING NUMBER	ITEM CODE	WT. KG
mm			
600	R-CARK-V24/600-S/S RVECKS/S	82828	12.3
750	R-CARK-V30/750-S/S RVECKS/S	82829	14.7
900	R-CARK-V36/900-S/S RVECKS/S	82830	16.5
1050	R-CARK-V42/1050-S/S RVECKS/S	82831	19.3
1200	R-CARK-V48/1200-S/S RVECKS/S	82832	21.6
1350	R-CARK-V54/1350-S/S RVECKS/S	82833	24.0
1500	R-CARK-V60/1500-S/S RVECKS/S	82834	26.4
1800	R-CARK-V72/1800-S/S RVECKS/S	82835	31.1
1500	R-CARK2-V60/1500-S/S RV2ECKSS	82836	31.6
1800	R-CARK2-V72/1800-S/S RV2ECKSS	82837	33.9
2100	R-CARK2-V84/2100-S/S RV2ECKSS	82838	38.6
2400	R-CARK2-V96/2400-S/S RV2ECKSS	82839	43.3
3000	R-CARK2-V120/3000-S/S RV2ECKSS	82840	52.8

\*NOTE: V-Tips can be used ONLY on vulcanised belts.

Stock items (non-shaded) refer to (\*) for specific lead time, if not specified, standard lead time applies.  
 Non-stock items (shaded) please contact Flexco for dispatch options and lead times.

# Replacement Parts List

## R-Type® SAC (Mild Steel) Secondary Cleaner with Service Advantage Cartridge™

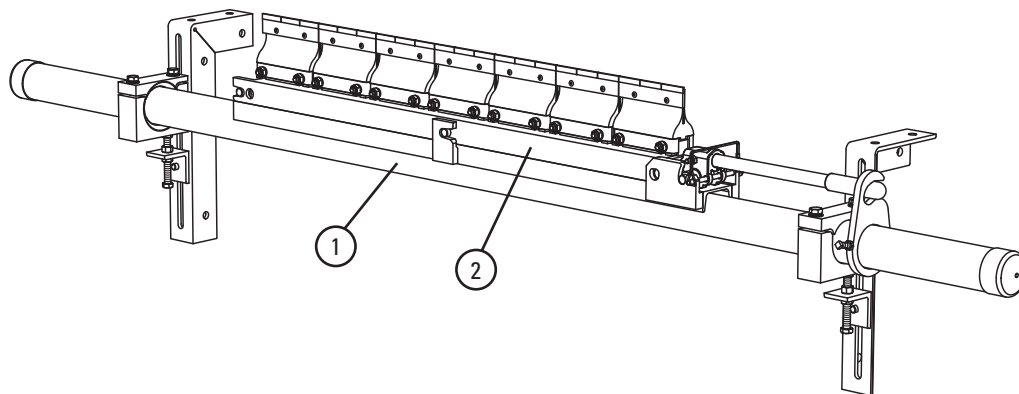

### Replacement Parts

REF	DESCRIPTION	ORDERING NUMBER	ITEM CODE	WT. KG
1	SAC Cartridge Pole 600mm	SACPL-24/600	77887	29.7
	SAC Cartridge Pole 750mm	SACPL-30/750	77888	32.3
	SAC Cartridge Pole 900mm	SACPL-36/900	77889	35.0
	SAC Cartridge Pole 1050mm	SACPL-42/1050	77890	37.6
	SAC Cartridge Pole 1200mm	SACPL-48/1200	77891	40.3
	SAC Cartridge Pole 1350mm	SACPL-54/1350	77892	42.9
	SAC Cartridge Pole 1500mm	SACPL-60/1500	77893	45.6
	SAC Cartridge Pole 1800mm	SACPL-72/1800	77894	50.9
	SAC Cartridge Center Pole 1500mm (Dual)	SACPL2-60/1500	77895	35.1
	SAC Cartridge Center Pole 1800mm (Dual)	SACPL2-72/1800	77896	40.6
	SAC Cartridge Center Pole 2100mm (Dual)	SACPL2-84/2100	77897	46.2
	SAC Cartridge Center Pole 2400mm (Dual)	SACPL2-96/2400	77898	51.8
	SAC Cartridge Center Pole 3000mm (Dual)	SACPL2-120/3000	77899	64.5
	1a	Extender Pole (for use with Dual Cartridge Center Pole)	MHP-EP	76392
2	SAC Repl Cartridge S/S 600mm	CART-24/600-S/S	78576	4.5
	SAC Repl Cartridge S/S 750mm	CART-30/750-S/S	78577	5.6
	SAC Repl Cartridge S/S 900mm	CART-36/900-S/S	78578	6.7
	SAC Repl Cartridge S/S 1050mm	CART-42/1050-S/S	78579	7.8
	SAC Repl Cartridge S/S 1200mm	CART-48/1200-S/S	78580	8.9
	SAC Repl Cartridge S/S 1350mm	CART-54/1350-S/S	78581	10.0
	SAC Repl Cartridge S/S 1500mm	CART-60/1500-S/S	78582	11.3
	SAC Repl Cartridge S/S 1800mm	CART-72/1800-S/S	78583	13.5
	SAC Repl Cartridge S/S 1500mm (Dual)	CART2-60/1500-S/S	78584	11.2
	SAC Repl Cartridge S/S 1800mm (Dual)	CART2-72/1800-S/S	78585	13.4
	SAC Repl Cartridge S/S 1950mm (Dual)	CART2-78/1950-S/S	78635	14.5
	SAC Repl Cartridge S/S 2100mm (Dual)	CART2-84/2100-S/S	78586	15.6
	SAC Repl Cartridge S/S 2400mm (Dual)	CART2-96/2400-S/S	78587	17.8
	SAC Repl Cartridge S/S 3000mm (Dual)	CART2-120/3000-S/S	78588	22.6

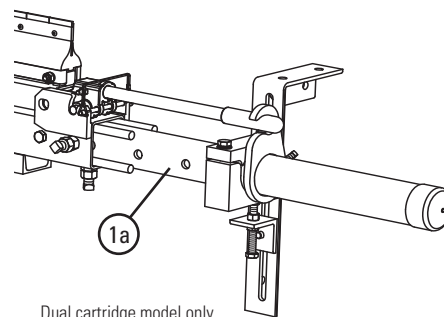

Dual cartridge model only

Stock items (non-shaded) refer to (\*) for specific lead time, if not specified, standard lead time applies.  
Non-stock items (shaded) please contact Flexco for dispatch options and lead times.

# Replacement Parts List

## R-Type® SAC (Mild Steel) Secondary Cleaner with Service Advantage Cartridge™

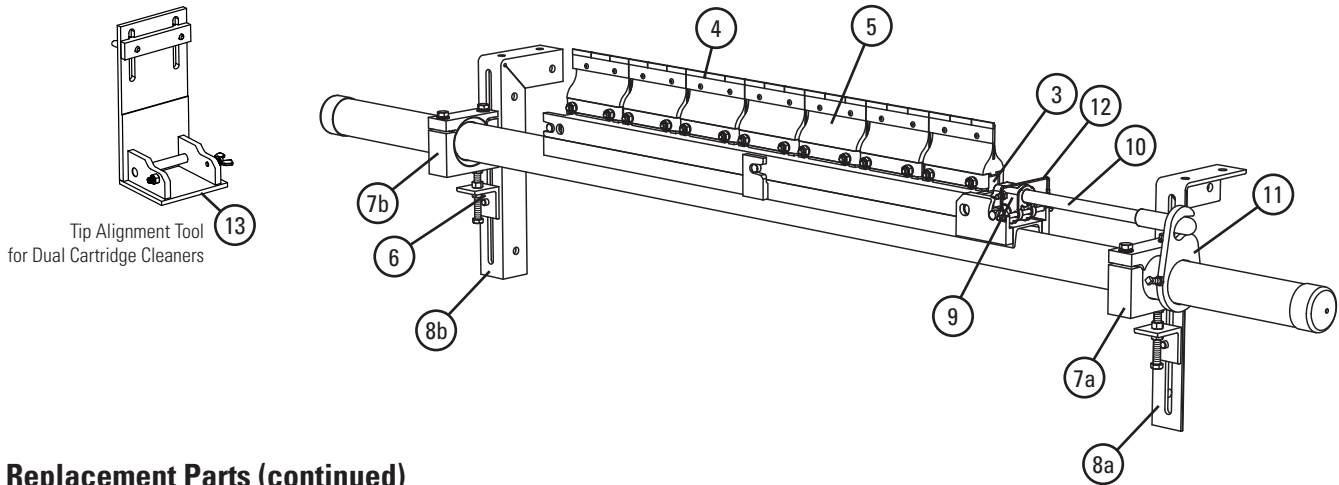

### Replacement Parts (continued)

REF	DESCRIPTION	ORDERING NUMBER	ITEM CODE	WT. KG
3	SAC Cartridge R-Type® Adapter Plate 600mm	RCAP-24/600	77921	2.9
	SAC Cartridge R-Type Adapter Plate 750mm §	RCAP-30/750	77922	3.6
	SAC Cartridge R-Type Adapter Plate 900mm §	RCAP-36/900	77923	4.3
	SAC Cartridge R-Type Adapter Plate 1050mm §	RCAP-42/1050	77924	5.0
	SAC Cartridge R-Type Adapter Plate 1200mm §	RCAP-48/1200	77925	5.7
	SAC Cartridge R-Type Adapter Plate 1350mm	RCAP-54/1350	77926	6.4
	SAC Cartridge R-Type Adapter Plate 1500mm §	RCAP-60/1500	77927	7.2
	SAC Cartridge R-Type Adapter Plate 1800mm	RCAP-72/1800	77928	8.6
4	R V-Tip* (for vulcanised belts only)	RSA150	73628	0.4
	Extra Life R - V-Tip (15mm) (for vulcanised belts only)	RSA150-EL15	61141	0.4
	Extra Life R - V-Tip (20mm) (for vulcanised belts only)	RSA150-XL	67776	0.7
	C-Tip*	ICT6	74535	0.4
5	Cushion*	RSA	76249	0.4
-	HD R Cushion	RSA-HD	69520	1.3
-	HD R Cushion - Stainless Steel	RC-HD-S/S	69521	1.5
6	P/R Adjusting Bracket	PAB	75513	0.4
7a	Cradle Clamp Block RH	SMR-CCB-R73	A2843	1.2
7b	Cradle Clamp Block LH	SMR-CCB-L73	A2842	1.2
8a	Mounting Bracket Kit, RH	PMBR	75519	3.8
8b	Mounting Bracket Kit, LH	PMBL	75516	3.8
9	SAC Removal Knuckle	SACRKN	77882	1.5
10	SAC Removal Handle	SACRH	77883	1.4
11	SAC Handle Lock Plate	SACRHL	77884	0.8
12	Knuckle Retainer Pin	SACKRP	77885	0.1
-	SAC Removal Kit (includes 1 ea. items 9,10,11,12)	SACRKT	77886	4.1
13	SAC Cartridge Tip Alignment Tool (Dual)	SAC2-TIP-TL	77866	1.1
-	Cradle Clamp Heavy-Duty Mounting Kit (inc. 2 ea. item 6; 1 ea. items 7a, 7b, 8a, 8b)	CRHMK	62400	10.8

§ If using a dual cartridge, please take the cleaner size and divide by two. That dimension is the size of the brackets needed for conversion to an R-Type cleaner.

Stock items (non-shaded) refer to (\*) for specific lead time, if not specified, standard lead time applies.  
Non-stock items (shaded) please contact Flexco for dispatch options and lead times.

# Replacement Parts List

## R-Type® SAC (Stainless Steel) Secondary Cleaner with Service Advantage Cartridge™

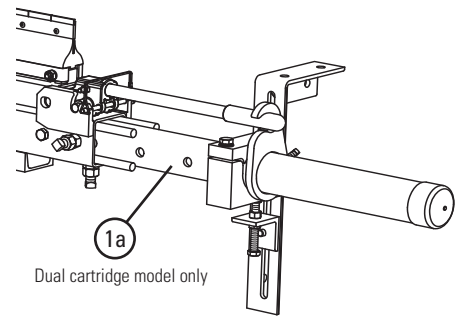
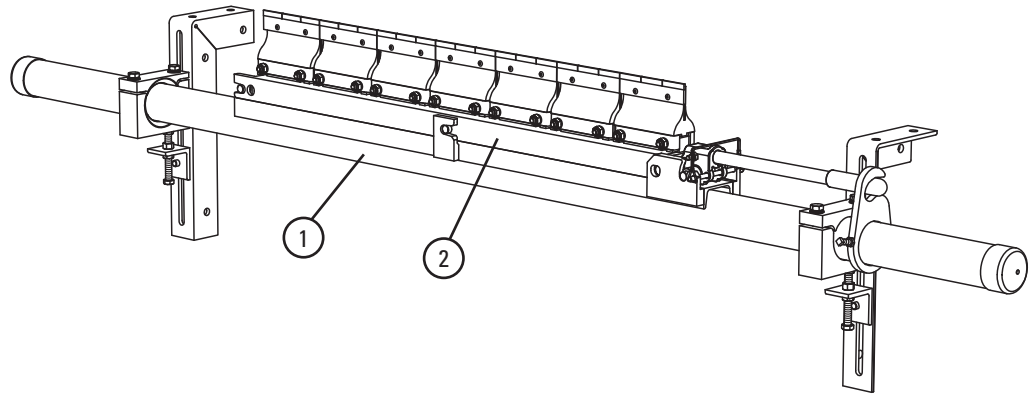

### Replacement Parts

REF	DESCRIPTION	ORDERING NUMBER	ITEM CODE	WT. KG
1	SAC S/S Cartridge Pole 600mm	SACPL-24/600-S/S	78371	29.7
	SAC S/S Cartridge Pole 750mm	SACPL-30/750-S/S	78372	32.3
	SAC S/S Cartridge Pole 900mm	SACPL-36/900-S/S	78373	35.0
	SAC S/S Cartridge Pole 1050mm	SACPL-42/1050-S/S	78374	37.6
	SAC S/S Cartridge Pole 1200mm	SACPL-48/1200-S/S	78375	40.3
	SAC S/S Cartridge Pole 1350mm	SACPL-54/1350-S/S	78376	42.9
	SAC S/S Cartridge Pole 1500mm	SACPL-60/1500-S/S	78377	45.6
	SAC S/S Cartridge Pole 1800mm	SACPL-72/1800-S/S	78378	50.9
	SAC S/S Cartridge Center Pole 1500mm (Dual)	SACPL2-60/1500-S/S	78379	35.1
	SAC S/S Cartridge Center Pole 1800mm (Dual)	SACPL2-72/1800-S/S	78380	40.6
	SAC S/S Cartridge Center Pole 1950mm (Dual)	SACPL2-78/1950-S/S	78642	43.9
	SAC S/S Cartridge Center Pole 2100mm (Dual)	SACPL2-84/2100-S/S	78381	46.2
	SAC S/S Cartridge Center Pole 2400mm (Dual)	SACPL2-96/2400-S/S	78382	51.8
	SAC S/S Cartridge Center Pole 3000mm (Dual)	SACPL2-120/3000-S/S	78383	64.5
1a	S/S Extender Pole (for use with S/S Dual Cartridge Center Pole)	MHP-EP-S/S	77599	24.5
2	SAC Repl Cartridge S/S 600mm	CART-24/600-S/S	78576	4.5
	SAC Repl Cartridge S/S 750mm	CART-30/750-S/S	78577	5.6
	SAC Repl Cartridge S/S 900mm	CART-36/900-S/S	78578	6.7
	SAC Repl Cartridge S/S 1050mm	CART-42/1050-S/S	78579	7.8
	SAC Repl Cartridge S/S 1200mm	CART-48/1200-S/S	78580	8.9
	SAC Repl Cartridge S/S 1350mm	CART-54/1350-S/S	78581	10.0
	SAC Repl Cartridge S/S 1500mm	CART-60/1500-S/S	78582	11.3
	SAC Repl Cartridge S/S 1800mm	CART-72/1800-S/S	78583	13.5
	SAC Repl Cartridge S/S 1500mm (Dual)	CART2-60/1500-S/S	78584	11.2
	SAC Repl Cartridge S/S 1800mm (Dual)	CART2-72/1800-S/S	78585	13.4
	SAC Repl Cartridge S/S 1950mm (Dual)	CART2-78/1950-S/S	78635	14.5
	SAC Repl Cartridge S/S 2100mm (Dual)	CART2-84/2100-S/S	78586	15.6
	SAC Repl Cartridge S/S 2400mm (Dual)	CART2-96/2400-S/S	78587	17.8
	SAC Repl Cartridge S/S 3000mm (Dual)	CART2-120/3000-S/S	78588	22.6

Stock items (non-shaded) refer to (\*) for specific lead time, if not specified, standard lead time applies.  
 Non-stock items (shaded) please contact Flexco for dispatch options and lead times.

# Replacement Parts List

## R-Type® SAC (Stainless Steel) Secondary Cleaner with Service Advantage Cartridge™

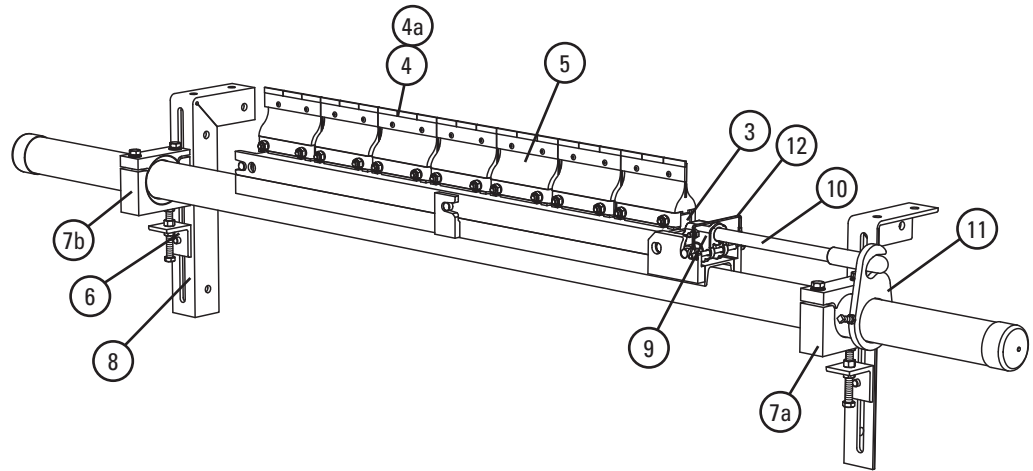
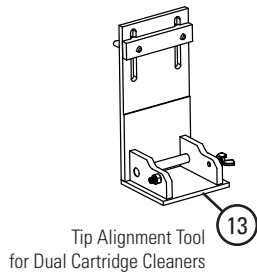

### Replacement Parts (continued)

REF	DESCRIPTION	ORDERING NUMBER	ITEM CODE	WT. KG
3	SAC Cartridge R-Type® S/S Adapter Plate 600mm	RCAP-24/600-S/S	78363	2.9
	SAC Cartridge R-Type S/S Adapter Plate 750mm §	RCAP-30/750-S/S	78364	3.6
	SAC Cartridge R-Type S/S Adapter Plate 900mm §	RCAP-36/900-S/S	78365	4.3
	SAC Cartridge R-Type S/S Adapter Plate 1050mm §	RCAP-42/1050-S/S	78366	5.0
	SAC Cartridge R-Type S/S Adapter Plate 1200mm §	RCAP-48/1200-S/S	78367	5.7
	SAC Cartridge R-Type S/S Adapter Plate 1350mm	RCAP-54/1350-S/S	78368	6.4
	SAC Cartridge R-Type S/S Adapter Plate 1500mm §	RCAP-60/1500-S/S	78369	7.2
	SAC Cartridge R-Type S/S Adapter Plate 1800mm	RCAP-72/1800-S/S	78370	8.6
4	C-Tip	ICT6	74535	0.4
4a	S/S V-Tip* (for vulcanised belts only)	RVT6-S/S	76205	0.4
5	S/S R Cushion*	RC-S/S	76250	1.4
-	HD R Cushion	RSA-HD	69520	1.3
-	HD R Cushion - Stainless Steel	RC-HD-S/S	69521	1.5
6	P/R Adjusting Bracket S/S	PAB-S/S	75515	0.4
7a	Cradle Clamp LH S/S CRDLBLK-LH	CRDLBLK-RH-S/S	A2825	1.2
7b	Cradle Clamp RH S/S CRDLBLK-RH	CRDLBLK-LH-S/S	A2826	1.2
8a	Mounting Bracket Kit RH S/S	PMBR-S/S	75521	3.8
8b	Mounting Bracket Kit LH S/S	PMBL-S/S	75518	3.8
9	SAC Removal Knuckle	SACRKN	77882	1.5
10	SAC Removal Handle S/S	SACRH-S/S	78397	1.4
11	SAC Handle Lock Plate S/S	SACRHL-S/S	78398	0.8
12	Knuckle Retainer Pin S/S	SACKRP-S/S	78399	0.1
-	SAC Removal Kit S/S (includes 1 ea. items 9,10,11,12)	SACRKT-S/S	78401	4.1
13	SAC Cartridge Tip Alignment Tool (Dual)	SAC2-TIP-TL	77866	1.1
-	Cradle Clamp Stainless Steel Heavy-Duty Mounting Kit (incl. 2 ea. item 6; incl. 1 ea. items 7a, 7b, 8a, 8b)	CRHMK-S/S	62095	10.8

§ If using a dual cartridge, please take the cleaner size and divide by two. That dimension is the size of the brackets needed for conversion to an R-Type cleaner.

Stock items (non-shaded) refer to (\*) for specific lead time, if not specified, standard lead time applies.  
 Non-stock items (shaded) please contact Flexco for dispatch options and lead times.



# Specifications & Guidelines

**R-Type<sup>®</sup> SAC**  
**Secondary Cleaner**  
*with Service Advantage Cartridge<sup>™</sup>*

## Pole Length Specifications\*

VERSION	CLEANER SIZE	BLADE WIDTH	POLE LENGTH	MAXIMUM CONVEYOR SPAN
	mm	mm	mm	mm
Single	600	600	1950	1650
	750	750	2100	1800
	900	900	2250	1950
	1050	1050	2400	2100
	1200	1200	2550	2250
	1350	1350	2700	2400
	1500	1500	2850	2550
Dual	1800	1800	3150	2850
	1500	1500	3000	2700
	1800	1800	3300	3000
	2100	2100	3600	3300
	2400	2400	3900	3600
	3000	3000	4500	4200

\*For special extra long pole length requirements a Pole Extender Kit (#76024) is available that provides 750mm of extended pole length. Pole Diameter - 73mm

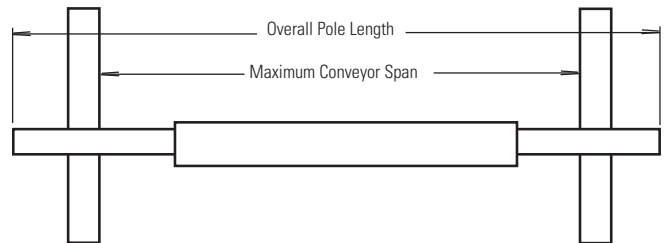

## Clearance Guidelines for Installation

VERSION	HORIZONTAL CLEARANCE REQUIRED	VERTICAL CLEARANCE REQUIRED
	mm	mm
Single	114	254
Dual	114	298

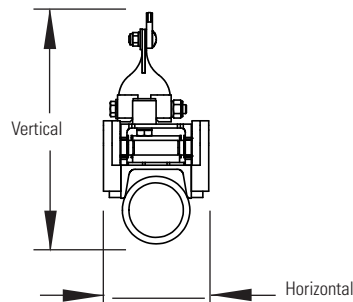

## Specifications:

- Maximum Belt Speed .....5 m/s
- Temperature Rating .....-35 to 82°C
- Usable Blade Wear Length.....9 mm
- Blade Materials .....C-Tip: Impact Resistant Tungsten Carbide (works with mechanical fasteners)  
V-Tip: Long Life Tungsten Carbide (for vulcanised belts only)
- Available for Belt Widths .....600 to 3000 mm. Other sizes available upon request.

# Product Ordering Information

## MHS SAC HD Secondary Cleaner with Service Advantage Cartridge™

### MHS SAC Secondary with V-Tips\*

BELT WIDTH mm	ORDERING NUMBER	ITEM CODE	WT. KG
600	MHS-600V-SAC	78162	88.5
750	MHS-750V-SAC	78163	93.7
900	MHS-900V-SAC	78164	99.1
1050	MHS-1050V-SAC	78165	104.4
1200	MHS-1200V-SAC	78166	109.6
1350	MHS-1350V-SAC	78167	114.8
1500	MHS-1500V-SAC	78168	120.2
1800	MHS-1800V-SAC	78169	130.8
1500	MHS-1500V-2SAC	78170	140.2
1800	MHS-1800V-2SAC	78171	151.0
2100	MHS-2100V-2SAC	78172	161.8
2400	MHS-2400V-2SAC	78173	172.9
3000	MHS-3000V-2SAC	78174	196.2

\*NOTE: V-Tips can be used ONLY on vulcanised belts.

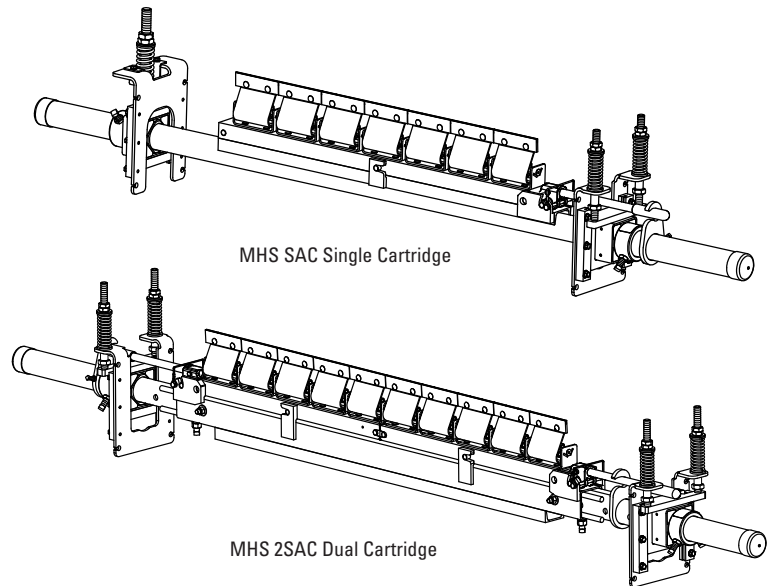

### MHS SAC Stainless Steel Secondary with V-Tips\*

BELT WIDTH mm	ORDERING NUMBER	ITEM CODE	WT. KG
600	MHS-600V-SAC-S/S	78537	88.5
750	MHS-750V-SAC-S/S	78538	93.7
900	MHS-900V-SAC-S/S	78539	99.1
1050	MHS-1050V-SAC-S/S	78540	104.4
1200	MHS-1200V-SAC-S/S	78541	109.6
1350	MHS-1350V-SAC-S/S	78542	114.8
1500	MHS-1500V-SAC-S/S	78543	120.2
1800	MHS-1800V-SAC-S/S	78544	130.8
1500	MHS-1500V-2SAC-S/S	78545	140.2
1800	MHS-1800V-2SAC-S/S	78546	151.0
1950	MHS-1950V-2SAC-S/S	78649	156.0
2100	MHS-2100V-2SAC-S/S	78547	161.8
2400	MHS-2400V-2SAC-S/S	78548	172.9
3000	MHS-3000V-2SAC-S/S	78549	196.2

\*NOTE: V-Tips can be used ONLY on vulcanised belts.

### Tips Required Per Cleaner Size

BELT WIDTH mm	BLADE COVERAGE mm	No. V-TIPS REQUIRED
600	600	4
750	750	5
900	900	6
1050	1050	7
1200	1200	8
1350	1350	9
1500	1500	10
1800	1800	12
2100	2100	14
2400	2400	16
3000	3000	20

### Product Notes:

- Patented Service Advantage Cartridge™ allows for easy removal in even the dirtiest conditions.
- Heavy-duty design to deliver maximum cleaning efficiency on the most demanding, abusive beltlines.
- Pole Length: Belt width plus 1350 mm (single cartridge cleaners); Belt width plus 1500 mm (dual cartridge cleaners).
- Patented PowerFlex™ cushion design to maintain continuous blade-to-belt contact and quick relief from passing mechanical splices.
- C-Tips are for mechanically fastened or vulcanised belts. V-Tips are for vulcanised belts only.
- Visual Blade Tension Check: Measure the tension spring and refer to Spring Length Chart on mounting base for the correct length for best cleaning performance.
- Tensioner mounting brackets included for fast and easy installation.
- Cartridge Removal Kit included for easy removal of the cartridge.

Stock items (non-shaded) refer to (\*) for specific lead time, if not specified, standard lead time applies.  
Non-stock items (shaded) please contact Flexco for dispatch options and lead times.

# Product Ordering Information

## MHS SAC HD Secondary Cleaner with Service Advantage Cartridge™

### MHS SAC Cartridge Kits with V-Tips\*

BELT WIDTH	ORDERING NUMBER	ITEM CODE	WT. KG
mm			
600	MHS-CARK-V24/600	77937	13.3
750	MHS-CARK-V30/750	77938	15.9
900	MHS-CARK-V36/900	77939	18.5
1050	MHS-CARK-V42/1050	77940	21.1
1200	MHS-CARK-V48/1200	77941	23.7
1350	MHS-CARK-V54/1350	77942	26.3
1500	MHS-CARK-V60/1500	77943	28.9
1800	MHS-CARK-V72/1800	77944	34.2
1500	MHS-CARK2-V60/1500	77950	31.8
1800	MHS-CARK2-V72/1800	77951	37.0
2100	MHS-CARK2-V84/2100	77952	42.2
2400	MHS-CARK2-V96/2400	77953	47.4
3000	MHS-CARK2-V120/3000	77954	57.9

\*NOTE: V-Tips can be used ONLY on vulcanised belts.

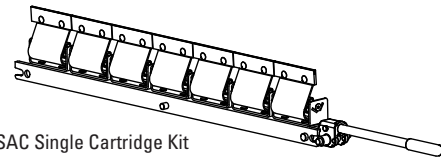

MHS SAC Single Cartridge Kit

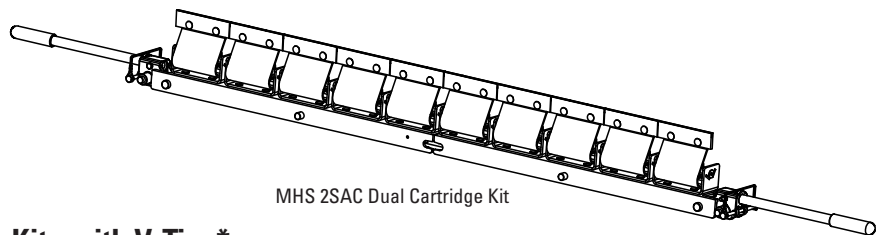

MHS 2SAC Dual Cartridge Kit

### MHS SAC Stainless Steel Cartridge Kits with V-Tips\*

BELT WIDTH	ORDERING NUMBER	ITEM CODE	WT. KG
mm			
600	MHS-CARK-V24/600-S/S MVECKS/S	82841	13.3
750	MHS-CARK-V30/750-S/S MVECKS/S	82842	15.9
900	MHS-CARK-V36/900-S/S MVECKS/S	82843	18.5
1050	MHS-CARK-V42/1050-S/S MVECKS/S	82844	21.1
1200	MHS-CARK-V48/1200-S/S MVECKS/S	82845	23.7
1350	MHS-CARK-V54/1350-S/S MVECKS/S	82846	26.3
1500	MHS-CARK-V60/1500-S/S MVECKS/S	82847	28.9
1800	MHS-CARK-V72/1800-S/S MVECKS/S	82848	34.2
1500	MHS-CARK2-V60/1500-S/S MV2CKSS	82849	31.8
1800	MHS-CARK2-V72/1800-S/S MV2CKSS	82850	37.0
2100	MHS-CARK2-V84/2100-S/S MV2CKSS	82851	42.2
2400	MHS-CARK2-V96/2400-S/S MV2CKSS	82852	47.4
3000	MHS-CARK2-V120/3000-S/S MV2CKS	82853	57.9

\*NOTE: V-Tips can be used ONLY on vulcanised belts.

Stock items (non-shaded) refer to (\*) for specific lead time, if not specified, standard lead time applies.  
Non-stock items (shaded) please contact Flexco for dispatch options and lead times.

# Replacement Parts List

## MHS SAC (Mild Steel) HD Secondary Cleaner with Service Advantage Cartridge™

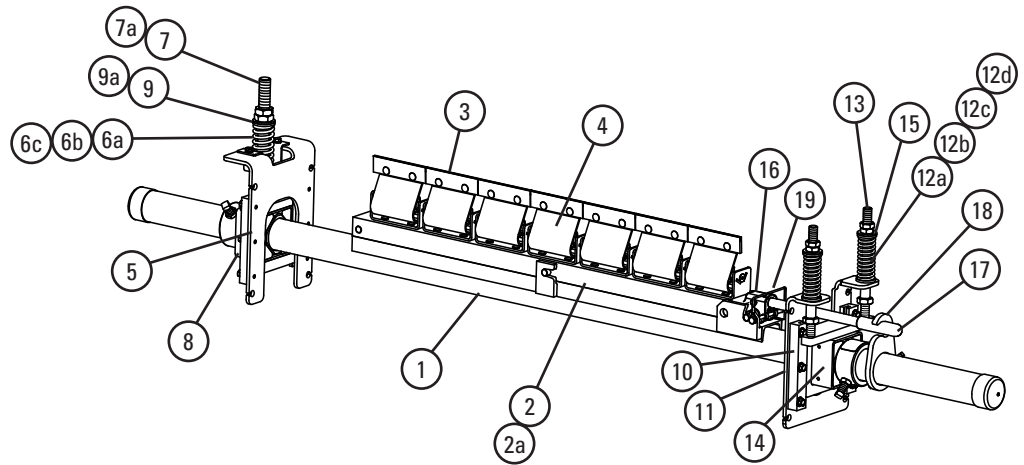

### Replacement Parts

REF	DESCRIPTION	ORDERING NUMBER	ITEM CODE	WT. KG
1	SAC Cartridge Pole 600mm	SACPL-24/600	77887	29.7
	SAC Cartridge Pole 750mm	SACPL-30/750	77888	32.3
	SAC Cartridge Pole 900mm	SACPL-36/900	77889	35.0
	SAC Cartridge Pole 1050mm	SACPL-42/1050	77890	37.6
	SAC Cartridge Pole 1200mm	SACPL-48/1200	77891	40.3
	SAC Cartridge Pole 1350mm	SACPL-54/1350	77892	42.9
	SAC Cartridge Pole 1500mm	SACPL-60/1500	77893	45.6
	SAC Cartridge Pole 1800mm	SACPL-72/1800	77894	50.9
	SAC Cartridge Center Pole 1500mm (Dual)	SACPL2-60/1500	77895	35.1
	SAC Cartridge Center Pole 1800mm (Dual)	SACPL2-72/1800	77896	40.6
	SAC Cartridge Center Pole 2100mm (Dual)	SACPL2-84/2100	77897	46.2
	SAC Cartridge Center Pole 2400mm (Dual)	SACPL2-96/2400	77898	51.8
	SAC Cartridge Center Pole 3000mm (Dual)	SACPL2-120/3000	77899	64.5
1a	Extender Pole (for use with Dual Cartridge Center Pole)	MHP-EP	76392	24.5
2	SAC Repl Cartridge S/S 600mm	CART-24/600-S/S	78576	4.5
	SAC Repl Cartridge S/S 750mm	CART-30/750-S/S	78577	5.6
	SAC Repl Cartridge S/S 900mm	CART-36/900-S/S	78578	6.7
	SAC Repl Cartridge S/S 1050mm	CART-42/1050-S/S	78579	7.8
	SAC Repl Cartridge S/S 1200mm	CART-48/1200-S/S	78580	8.9
	SAC Repl Cartridge S/S 1350mm	CART-54/1350-S/S	78581	10.0
	SAC Repl Cartridge S/S 1500mm	CART-60/1500-S/S	78582	11.3
	SAC Repl Cartridge S/S 1800mm	CART-72/1800-S/S	78583	13.5
	SAC Repl Cartridge S/S 1500mm (Dual)	CART2-60/1500-S/S	78584	11.2
	SAC Repl Cartridge S/S 1800mm (Dual)	CART2-72/1800-S/S	78585	13.4
	SAC Repl Cartridge S/S 1950mm (Dual)	CART2-78/1950-S/S	78635	14.5
	SAC Repl Cartridge S/S 2100mm (Dual)	CART2-84/2100-S/S	78586	15.6
	SAC Repl Cartridge S/S 2400mm (Dual)	CART2-96/2400-S/S	78587	17.8
	SAC Repl Cartridge S/S 3000mm (Dual)	CART2-120/3000-S/S	78588	22.6
	3	V-Tip* (for vulcanised belts only)	RSA150	73628
Extra Life R - V-Tip (15mm) (for vulcanised belts only)		RSA150-EL15	61141	0.4
Extra Life R - V-Tip (20mm) (for vulcanised belts only)		RSA150-XL	67776	0.7
C-Tip*		ICT6	74535	0.4
4	PowerFlex™ Cushion*	SPFC	79200	0.9
5	SST XD Mounting Base Kit* (includes 1 mounting base, 2 slide guides, top hat bracket & bottom bushing)	SSTXDMK	91412	4.6

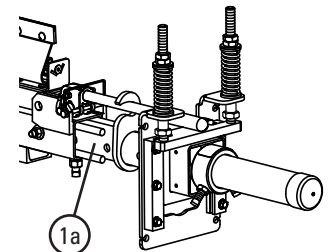

Dual cartridge model only

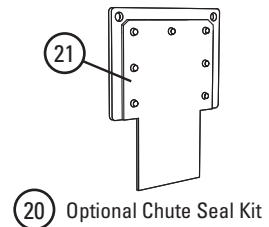

Optional Chute Seal Kit

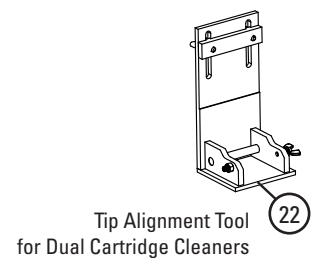

Tip Alignment Tool  
for Dual Cartridge Cleaners

Stock items (non-shaded) refer to (\*) for specific lead time, if not specified, standard lead time applies.  
Non-stock items (shaded) please contact Flexco for dispatch options and lead times.

# Replacement Parts List

## MHS SAC (Mild Steel) HD® Secondary Cleaner with Service Advantage Cartridge™

### Replacement Parts (continued)

REF	DESCRIPTION	ORDERING NUMBER	ITEM CODE	WT. KG
6a	Tension Spring - White (1 ea.) for belts 450-750mm	STS-W	75846	0.2
6b	Tension Spring - Silver (1 ea.) for belts 900-1500mm	STS-S	75843	0.4
6c	Tension Spring - Black (1 ea.) for belts 1800-2100mm	STS-B	75844	0.5
6d	Tension Spring - Gold (1 ea.) for belts over 2100mm	STS-G	78142	0.7
7	Adj Rod Kit* (incl. 1 rod, 2 nuts, 2 bushings, 1 washer) for belts 450-1500 mm	STAK	75847	1.3
7a	HD Adj Rod Kit* (incl. 1 rod, 2 nuts, 2 HD bushings, 1 washer) for belts 1800-2100mm	STAKHD	75892	1.4
8	SST HD Torsion Pole Mount* (1 ea.)	SSTHDPM	77868	6.8
9	SST Bushing Kit - White/Silver	SSTBK-W	76636	0.1
9a	SST Bushing Kit - Black	SSTBK-B	76637	0.1
10	ST Slide Guide Kit	STGK2	77635	0.5
-	SST HD Cartridge Tensioner - White (includes 1 ea. item 5, 6a, 7, 8) for belts 450-750 mm	SST1HDM-W	78517	13.7
-	SST HD Cartridge Tensioner - Silver (includes 1 ea. item 5, 6b, 7, 8) for belts 900-1500 mm	SST1HDM-S	78518	13.9
-	SST HD Cartridge Tensioner - Black (includes 1 ea. item 5, 6c, 7a, 8) for belts 1800-2100 mm	SST1HDM-B	78519	14.1
-	SST HD Cartridge Tensioner - Gold (includes 1 ea. item 5, 6d, 7a, 8) for belts over 2100 mm	SST1HDM-G	79069	14.3
11	CST HD Mounting Base Kit*	CSTHDMK	77871	3.9
12a	CST Spring - White (1 ea.) for belts 450-750 mm	CTS-W	77742	0.2
12b	CST Spring - Silver (1 ea.) for belts 900-1500 mm	CTS-S	77743	0.2

REF	DESCRIPTION	ORDERING NUMBER	ITEM CODE	WT. KG
12c	CST Spring - Black (1 ea.) for belts 1800-2100 mm	CTS-B	77744	0.3
12d	CST Spring - Gold (1 ea.) for belts 2400-3000 mm	CTS-G	77745	0.4
13	CST Adj Rod Kit (incl. 2 rods, 4 nuts, 4 bushings, 2 washers)	CSTAK	77031	1.5
14	CST HD Torsion Pole Mount* (1 ea.)	CSTHDPM	77869	7.4
15	CST Bushing Kit (includes 4 bushings)	CSTBK	77037	0.1
-	CST HD Cartridge Tensioner - White (incl. 1 ea. item 11, 13, 14 and 2 ea. item 12) for belts 450-750 mm	CST1HDM-W	78513	13.7
-	CST HD Cartridge Tensioner - Silver (incl. 1 ea. item 11, 13, 14 and 2 ea. item 12a) for belts 900-1500 mm	CST1HDM-S	78514	13.7
-	CST HD Cartridge Tensioner - Black (includes 1 ea. item 11, 13, 14 and 2 ea. item 12b) for belts 1800-2100 mm	CST1HDM-B	78515	13.7
-	CST HD Cartridge Tensioner - Gold (includes 1 ea. item 11, 13, 14 and 2 ea. item 12c) for belts 2400-3000 mm	CST1HDM-G	78516	13.9
16	SAC Removal Knuckle	SACRKN	77882	1.5
17	SAC Removal Handle	SACRH	77883	1.4
18	SAC Handle Lock Plate	SACRHL	77884	0.8
19	Knuckle Retainer Pin	SACKRP	77885	0.1
-	SAC Removal Kit (includes 1 ea. items 16, 17, 18, 19)	SACRKT	77886	4.1
20	SAC Chute Seal Kit	SACSK	77052	1.8
21	SAC Chute Seal Replacement Cover	SACSRC	77065	0.2
22	SAC Cartridge Tip Alignment Tool (Dual)	SAC2-TIP-TL	77866	1.1

### Primary Replacement Parts

DESCRIPTION	ORDERING NUMBER	ITEM CODE	WT. KG
Primary Air Tension 60mm Complete Kit*	ATVKP-60	63861	15.2
Primary Air Tension 73mm Complete Kit*	ATVKP-73	63862	16.6
Air Tank Kit with PAT & Control Box 100psi**	ATV73-SS	66192	35.0

\*includes 1 each: Mounting brackets, air bag, adjusting arm and hardware  
\*\*includes 1 each of 63862, 65803, 65571 & 66068

### Secondary Replacement Parts

REF	DESCRIPTION	ORDERING NUMBER	ITEM CODE	WT. KG
1	Mounting Bracket LH	PMBL-S/S	75518	3.8
2	Mounting Bracket RH	PMBR-S/S	75521	3.8
3	Air Tensioner Slider	ATV-SLIDE	62425	0.2
4	Air Tension Cradle Blocks 60mm Kit	ATV-MOUNT	62424	2.4
5	Air Tension Cradle Blocks 73mm Kit	ATV-MOUNT	63073	2.4
6	Air Tension Adjusting Angle	ATV-ANGLE	62426	1.0
-	Secondary Air Tension 60mm Complete Kit*	ATVK-60	62409	13.0
-	Secondary Air Tension 73mm Complete Kit*	ATVK-73	63072	15.0
-	Air Tank Kit with PAT & Control Box 100psi**	ATVK73-SEC-SS	64743	33.0

\*includes 1 each: mounting brackets, air tension slider, cradle kit, adjusting angle, air bag and hardware  
\*\*includes 1 each of 63072, 65803, 65571 & 66068

### Common Replacement Parts

REF	DESCRIPTION	ORDERING NUMBER	ITEM CODE	WT. KG
-	PAT 10MM Black Nylon Tube 20M	ATV-TUBE	66068	0.1
7	Air Bag	ATV-BAG	62079	0.2
8	Hex Nut S/S	HEX NUT	G1211	0.1
9	Air Line Adaptor	ATV-NIP	62037	0.1
10	PAT Control Box 60psi	PACB60	66055	5.0
11	PAT Control Box 100psi	PACB100	65803	5.0
-	PAT1 Tank	PAT1	65571	10.0

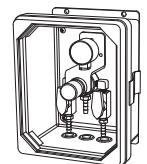
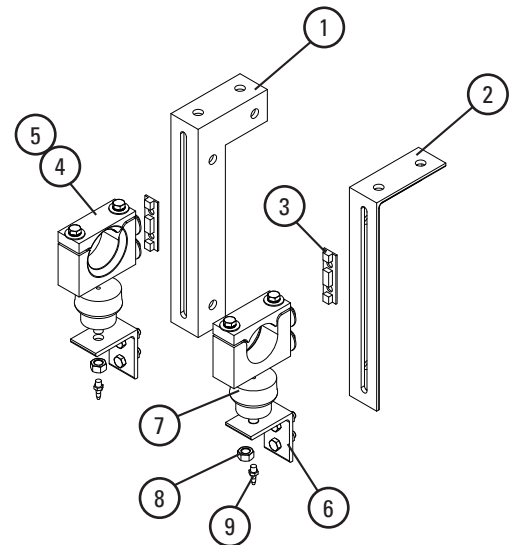

- 10 PAT Control Box 60psi
- 11 PAT Control Box 100psi

Stock items (non-shaded) refer to (\*) for specific lead time, if not specified, standard lead time applies.  
Non-stock items (shaded) please contact Flexco for dispatch options and lead times.

# Replacement Parts List

## MHS SAC (Stainless Steel) HD® Secondary Cleaner with Service Advantage Cartridge™

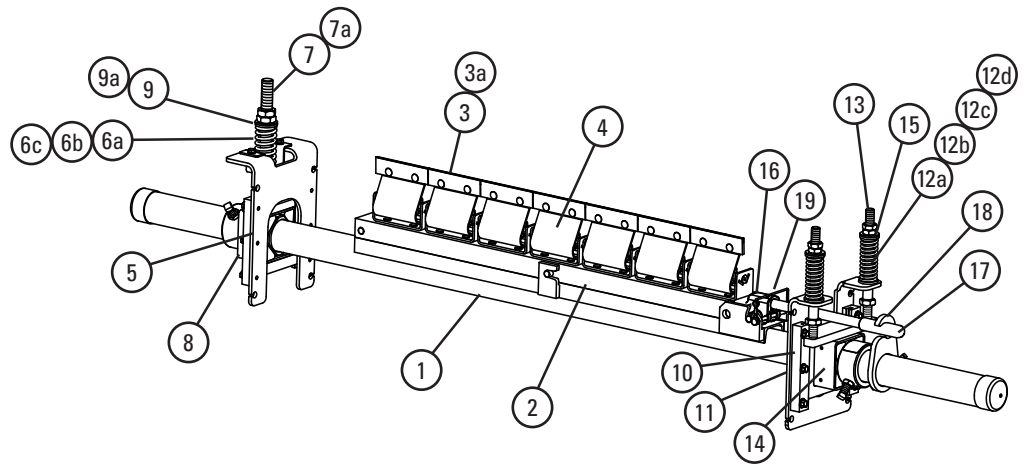

### Replacement Parts

REF	DESCRIPTION	ORDERING NUMBER	ITEM CODE	WT. KG
1	SAC S/S Cartridge Pole 600mm	SACPL-24/600-S/S	78371	29.7
	SAC S/S Cartridge Pole 750mm	SACPL-30/750-S/S	78372	32.3
	SAC S/S Cartridge Pole 900mm	SACPL-36/900-S/S	78373	35.0
	SAC S/S Cartridge Pole 1050mm	SACPL-42/1050-S/S	78374	37.6
	SAC S/S Cartridge Pole 1200mm	SACPL-48/1200-S/S	78375	40.3
	SAC S/S Cartridge Pole 1350mm	SACPL-54/1350-S/S	78376	42.9
	SAC S/S Cartridge Pole 1500mm	SACPL-60/1500-S/S	78377	45.6
	SAC S/S Cartridge Pole 1800mm	SACPL-72/1800-S/S	78378	50.9
	SAC S/S Cartridge Center Pole 1500mm (Dual)	SACPL2-60/1500-S/S	78379	35.1
	SAC S/S Cartridge Center Pole 1800mm (Dual)	SACPL2-72/1800-S/S	78380	40.6
	SAC S/S Cartridge Center Pole 1950mm (Dual)	SACPL2-78/1950-S/S	78642	43.9
	SAC S/S Cartridge Center Pole 2100mm (Dual)	SACPL2-84/2100-S/S	78381	46.2
	SAC S/S Cartridge Center Pole 2400mm (Dual)	SACPL2-96/2400-S/S	78382	51.8
	SAC S/S Cartridge Center Pole 3000mm (Dual)	SACPL2-120/3000-S/S	78383	64.5
1a	S/S Extender Pole (for use with S/S Dual Cartridge Center Pole)	MHP-EP-S/S	77599	24.5
2	SAC Repl Cartridge S/S 600mm	CART-24/600-S/S	78576	4.5
	SAC Repl Cartridge S/S 750mm	CART-30/750-S/S	78577	5.6
	SAC Repl Cartridge S/S 900mm	CART-36/900-S/S	78578	6.7
	SAC Repl Cartridge S/S 1050mm	CART-42/1050-S/S	78579	7.8
	SAC Repl Cartridge S/S 1200mm	CART-48/1200-S/S	78580	8.9
	SAC Repl Cartridge S/S 1350mm	CART-54/1350-S/S	78581	10.0
	SAC Repl Cartridge S/S 1500mm	CART-60/1500-S/S	78582	11.3
	SAC Repl Cartridge S/S 1800mm	CART-72/1800-S/S	78583	13.5
	SAC Repl Cartridge S/S 1500 mm (Dual)	CART2-60/1500-S/S	78584	11.2
	SAC Repl Cartridge S/S 1800mm (Dual)	CART2-72/1800-S/S	78585	13.4
	SAC Repl Cartridge S/S 1950mm (Dual)	CART2-78/1950-S/S	78635	14.5
	SAC Repl Cartridge S/S 2100mm (Dual)	CART2-84/2100-S/S	78586	15.6
	SAC Repl Cartridge S/S 2400mm (Dual)	CART2-96/2400-S/S	78587	17.8
	SAC Repl Cartridge S/S 3000mm (Dual)	CART2-120/3000-S/S	78588	22.6

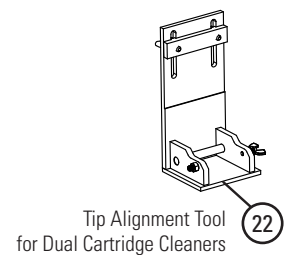
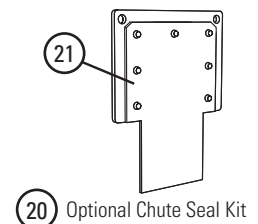
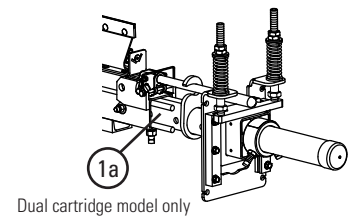

Stock items (non-shaded) refer to (\*) for specific lead time, if not specified, standard lead time applies.  
Non-stock items (shaded) please contact Flexco for dispatch options and lead times.



# Replacement Parts List

**MHS SAC (Stainless Steel)**  
**HD® Secondary Cleaner**  
 with Service Advantage Cartridge™

## Replacement Parts (continued)

REF	DESCRIPTION	ORDERING NUMBER	ITEM CODE	WT. KG
3	C-Tip	ICT6	74535	0.4
3a	S/S V-Tip* (for vulcanised belts only)	RVT6-S/S	76205	0.4
4	PowerFlex™ Cushion, S/S*	SPFC-S/S	79201	0.9
5	SST HD® Mounting Base Kit, S/S*	STHDMK2-S/S	77634	4.6
6a	SST Spring - White S/S (1 ea.)	STS-W-S/S	77630	0.2
6b	SST Spring - Silver S/S (1 ea.)	STS-S-S/S	77631	0.4
6c	SST Spring - Black S/S (1 ea.)	STS-B-S/S	77632	0.5
7	SST Adj Rod Kit*(incl. 1 rod, 2 nuts, 2 bushings, 1 washer) for belts 450-1500 mm	STAK	75847	1.3
7a	SST HD Adj Rod Kit*(incl. 1 rod, 2 nuts, 2 HD bushings, 1 washer) for belts 1800-2100mm	STAKHD	75892	1.4
8	SST HD Torsion Pole Mount S/S* (1 ea.)	STHDPM2-S/S	77633	6.8
9	SST Bushing Kit - White/Silver	SSTBK-W	76636	0.1
9a	SST Bushing Kit - Black/Gold	SSTBK-B	76637	0.1
10	ST Slide Guide Kit	STGK2	77635	0.5
-	SST HD Cartridge Tensioner S/S - White (includes 1 ea. item 5, 6a, 7, 9) for belts 450-750 mm	SST1HDM-W-S/S	78394	13.7
-	SST HD Cartridge Tensioner S/S - Silver (includes 1 ea. item 5, 6b, 7, 9) for belts 900-1500 mm	SST1HDM-S-S/S	78395	13.9
-	SST HD Cartridge Tensioner S/S - Black (includes 1 ea. item 5, 6c, 7a, 9a) for belts 1800-2100 mm	SST1HDM-B-S/S	78396	14.1
-	SST HD Cartridge Tensioner - Gold (includes 1 ea. item 8, 10, 13, 14) for belts over 2100 mm	SST1HDM-G	79069	14.3
11	CST HD Mounting Base Kit S/S*	CSTHDMK-S/S	78384	3.9
12a	CST Spring - White S/S (1 ea.) for belts 450-750 mm	CTS-W-S/S	78385	0.2
12b	CST Spring - Silver S/S (1 ea.) for belts 900-1500 mm	CTS-S-S/S	78386	0.2
12c	CST Spring - Black S/S (1 ea.) for belts 1800-2100 mm	CTS-B-S/S	78387	0.3
12d	CST Spring - Gold S/S (1 ea.) for belts 2400-3000 mm	CTS-G-S/S	78388	0.4
13	CST Adj Rod Kit (incl. 2 rods, 4 nuts, 4 bushings, 2 washers)	CSTAK	77031	1.5
14	CST HD Torsion Pole Mount S/S* (1 ea.)	CSTHDPM-S/S	78389	7.4
15	CST Bushing Kit (includes 4 bushings)	CSTBK	77037	0.1
-	CST HD Cartridge Tensioner S/S - White (incl. 1 ea. item 11,13,14, 15 and 2 ea. item 12a) for belts 450-750 mm	CST1HDM-W-S/S	78390	13.7
-	CST HD Cartridge Tensioner S/S - Silver (incl. 1 ea. item 11,13,14, 15 and 2 ea. item 12b) for belts 900-1500 mm	CST1HDM-S-S/S	78391	13.7
-	CST HD Cartridge Tensioner S/S - Black (includes 1 ea. item 11,13,14, 15 and 2 ea. item 12c) for belts 1800-2100 mm	CST1HDM-B-S/S	78392	13.7
-	CST HD Cartridge Tensioner S/S - Gold (includes 1 ea. item 11,13,14, 15 and 2 ea. item 12d) for belts 2400-3000 mm	CST1HDM-G-S/S	78393	13.9
16	SAC Removal Knuckle	SACRKN	77882	1.5
17	SAC Removal Handle S/S	SACRH-S/S	78397	1.4
18	SAC Handle Lock Plate S/S	SACRHL-S/S	78398	0.8
19	Knuckle Retainer Pin S/S	SACKRP-S/S	78399	0.1
-	SAC Removal Kit S/S (includes 1 ea. items 16,17,18,19)	SACRKT-S/S	78401	4.1
20	SAC Chute Seal Kit	SACSK	77052	1.8
21	SAC Chute Seal Replacement Cover	SACSRC	77065	0.2
22	SAC Cartridge Tip Alignment Tool (Dual)	SAC2-TIP-TL	77866	1.1

Stock items (non-shaded) refer to (\*) for specific lead time, if not specified, standard lead time applies.  
 Non-stock items (shaded) please contact Flexco for dispatch options and lead times.



# Specifications & Guidelines

**MHS SAC**  
**HD<sup>®</sup> Secondary Cleaner**  
*with Service Advantage Cartridge™*

## Pole Length Specifications\*

VERSION	CLEANER SIZE	BLADE WIDTH	POLE LENGTH	MAXIMUM CONVEYOR SPAN
	mm	mm	mm	mm
Single	600	600	1950	1650
	750	750	2100	1800
	900	900	2250	1950
	1050	1050	2400	2100
	1200	1200	2550	2250
	1350	1350	2700	2400
	1500	1500	2850	2550
Dual	1800	1800	3150	2850
	1500	1500	3000	2700
	1800	1800	3300	3000
	2100	2100	3600	3300
	2400	2400	3900	3600
	3000	3000	4500	4200

\*For special extra long pole length requirements a Pole Extender Kit (#76024) is available that provides 750 mm of extended pole length. Pole Diameter - 73 mm

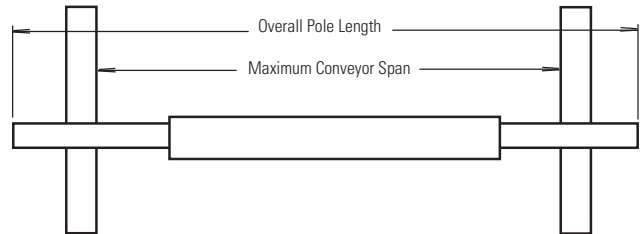

## Clearance Guidelines for Installation

VERSION	HORIZONTAL CLEARANCE REQUIRED	VERTICAL CLEARANCE REQUIRED
	mm	mm
Single	114	279
Dual	114	318

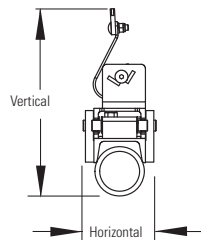

## Aluminum Content

ALUMINUM ALLOY TYPE	PERCENT	
	MG MAGNESIUM	TI TITANIUM
6061	1.0%	0.0%

## SST XD Spring Length Chart

Blade Width	White Springs	Silver Springs	Black Springs
mm	mm	mm	mm
600	78	99	N/A
750	72	97	N/A
900	N/A	94	98
1050	N/A	91	95
1200	N/A	88	93
1350	N/A	86	91
1500	N/A	83	89
1800	N/A	N/A	84

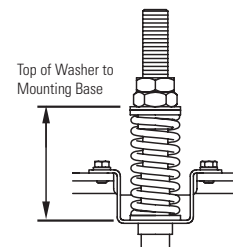

Shading indicates preferred spring option.

## CST Spring Length Chart

Blade Width	White Springs	Silver Springs	Black Springs	Gold Springs
mm	mm	mm	mm	mm
600	78	99	N/A	N/A
750	72	97	N/A	N/A
900	N/A	94	98	N/A
1050	N/A	91	95	N/A
1200	N/A	88	93	N/A
1350	N/A	86	91	N/A
1500	N/A	83	89	103
1800	N/A	N/A	84	101
2100	N/A	N/A	80	99
2400	N/A	N/A	N/A	97
3000	N/A	N/A	N/A	93

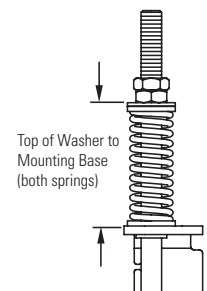

Shading indicates preferred spring option.

## Specifications:

- Maximum Belt Speed..... 6 m/s
- Temperature Rating..... -35 to 82°C
- Usable Blade Wear Length..... 9 mm
- Blade Materials..... C-Tip: Impact Resistant Tungsten Carbide (works with mechanical fasteners)  
V-Tip: Long Life Tungsten Carbide (for vulcanised belts only)
- Available for Belt Widths..... 600 to 3000 mm. Other sizes available upon request.

# Product Ordering Information

## MHS SAC BT HD® Secondary Cleaner with Service Advantage Cartridge™ & Bolt Tensioner

### MHS SAC Secondary with V-Tips\*

BELT WIDTH	ORDERING NUMBER	ITEM CODE	WT. KG
mm			
600	MHS-600BTV-SAC	78007	61.4
750	MHS-750BTV-SAC	78008	66.4
900	MHS-900BTV-SAC	78009	71.6
1050	MHS-1050BTV-SAC	78010	77.2
1200	MHS-1200BTV-SAC	78011	82.0
1350	MHS-1350BTV-SAC	78012	87.1
1500	MHS-1500BTV-SAC	78013	92.4
1800	MHS-1800BTV-SAC	78014	102.7
1500	MHS-1500BTV-2SAC	78015	105.2
1800	MHS-1800BTV-2SAC	78016	120.7
2100	MHS-2100BTV-2SAC	78017	131.4
2400	MHS-2400BTV-2SAC	78018	142.0
3000	MHS-3000BTV-2SAC	78019	165.0

\*NOTE: V-Tips can be used ONLY on vulcanised belts.

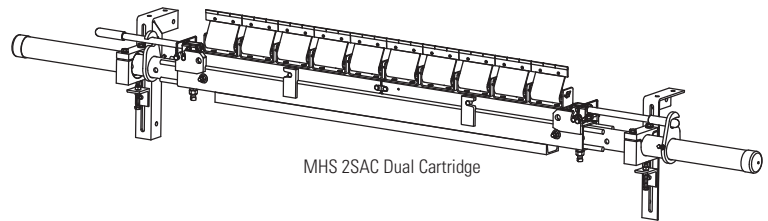
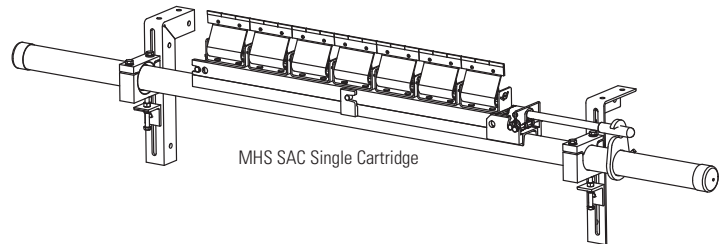

### MHS SAC Stainless Steel Secondary with V-Tips\*

BELT WIDTH	ORDERING NUMBER	ITEM CODE	WT. KG
mm			
600	MHS-600BTV-SAC-S/S	78316	61.4
750	MHS-750BTV-SAC-S/S	78317	66.4
900	MHS-900BTV-SAC-S/S	78318	71.6
1050	MHS-1050BTV-SAC-S/S	78319	77.2
1200	MHS-1200BTV-SAC-S/S	78320	82.0
1350	MHS-1350BTV-SAC-S/S	78321	87.1
1500	MHS-1500BTV-SAC-S/S	78322	92.4
1800	MHS-1800BTV-SAC-S/S	78323	102.7
1500	MHS-1500BTV-2SAC-S/S	78324	105.2
1800	MHS-1800BTV-2SAC-S/S	78325	120.7
1950	MHS-1950BTV-2SAC-S/S	66255	126.0
2100	MHS-2100BTV-2SAC-S/S	78326	131.4
2400	MHS-2400BTV-2SAC-S/S	78327	142.0
3000	MHS-3000BTV-2SAC-S/S	78328	165.0

\*NOTE: V-Tips can be used ONLY on vulcanised belts.

### Replacement Tips

ORDERING NUMBER	ITEM CODE	WT. KG
RSA150 (V-Tip)	73628	0.4

### Tips Required Per Cleaner Size

BELT WIDTH	BLADE COVERAGE	NO. V-TIPS REQUIRED
mm	mm	
600	600	4
750	750	5
900	900	6
1050	1050	7
1200	1200	8
1350	1350	9
1500	1500	10
1800	1800	12
2100	2100	14
2400	2400	16
3000	3000	20

### Product Notes:

- Patented Service Advantage Cartridge™ allows for easy removal in even the dirtiest conditions.
- Heavy-duty design to deliver maximum cleaning efficiency on the most demanding, abusive beltlines.
- Pole Length: Belt width plus 1350 mm (single cartridge cleaners); Belt width plus 1500 mm (dual cartridge cleaners).
- Patented PowerFlex™ cushion design to maintain continuous blade-to-belt contact and quick relief from passing mechanical splices.
- C-Tips are for mechanically fastened or vulcanised belts. V-Tips are for vulcanised belts only.
- Visual Blade Tension Check: Measure the tension spring and refer to Spring Length Chart on mounting base for the correct length for best cleaning performance.
- Tensioner mounting brackets included for fast and easy installation.
- Cartridge Removal Kit included for easy removal of the cartridge.

Stock items (non-shaded) refer to (\*) for specific lead time, if not specified, standard lead time applies.  
Non-stock items (shaded) please contact Flexco for dispatch options and lead times.

# Product Ordering Information

## MHS SAC BT HD<sup>®</sup> Secondary Cleaner with Service Advantage Cartridge™ & Bolt Tensioner

### MHS SAC Cartridge Kits with V-Tips\*

BELT WIDTH	ORDERING NUMBER	ITEM CODE	WT. KG
mm			
600	MHS-CARK-V24/600	77937	13.3
750	MHS-CARK-V30/750	77938	15.9
900	MHS-CARK-V36/900	77939	18.5
1050	MHS-CARK-V42/1050	77940	21.1
1200	MHS-CARK-V48/1200	77941	23.7
1350	MHS-CARK-V54/1350	77942	26.3
1500	MHS-CARK-V60/1500	77943	28.9
1800	MHS-CARK-V72/1800	77944	34.2
1500	MHS-CARK2-V60/1500	77950	31.8
1800	MHS-CARK2-V72/1800	77951	37.0
2100	MHS-CARK2-V84/2100	77952	42.2
2400	MHS-CARK2-V96/2400	77953	47.4
3000	MHS-CARK2-V120/3000	77954	57.9

\*NOTE: V-Tips can be used ONLY on vulcanised belts.

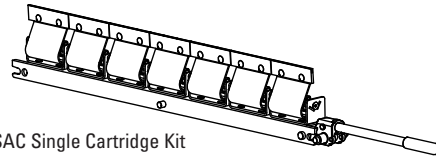

MHS SAC Single Cartridge Kit

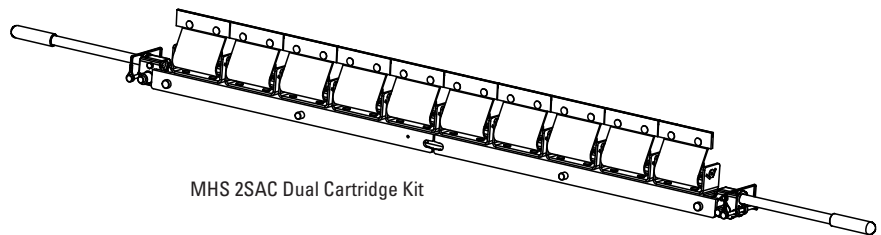

MHS 2SAC Dual Cartridge Kit

### MHS SAC Stainless Steel Cartridge Kits with V-Tips\*

BELT WIDTH	ORDERING NUMBER	ITEM CODE	WT. KG
mm			
600	MHS-CARK-V24/600-S/S MVECKS/S	82841	13.3
750	MHS-CARK-V30/750-S/S MVECKS/S	82842	15.9
900	MHS-CARK-V36/900-S/S MVECKS/S	82843	18.5
1050	MHS-CARK-V42/1050-S/S MVECKS/S	82844	21.1
1200	MHS-CARK-V48/1200-S/S MVECKS/S	82845	23.7
1350	MHS-CARK-V54/1350-S/S MVECKS/S	82846	26.3
1500	MHS-CARK-V60/1500-S/S MVECKS/S	82847	28.9
1800	MHS-CARK-V72/1800-S/S MVECKS/S	82848	34.2
1500	MHS-CARK2-V60/1500-S/S MV2CKSS	82849	31.8
1800	MHS-CARK2-V72/1800-S/S MV2CKSS	82850	37.0
2100	MHS-CARK2-V84/2100-S/S MV2CKSS	82851	42.2
2400	MHS-CARK2-V96/2400-S/S MV2CKSS	82852	47.4
3000	MHS-CARK2-V120/3000-S/S MV2CKSS	82853	57.9

\*NOTE: V-Tips can be used ONLY on vulcanised belts.

Stock items (non-shaded) refer to (\*) for specific lead time, if not specified, standard lead time applies.  
Non-stock items (shaded) please contact Flexco for dispatch options and lead times.

# Replacement Parts List

## MHS SAC BT (Mild Steel) HD® Secondary Cleaner with Service Advantage Cartridge™ & Bolt Tensioner

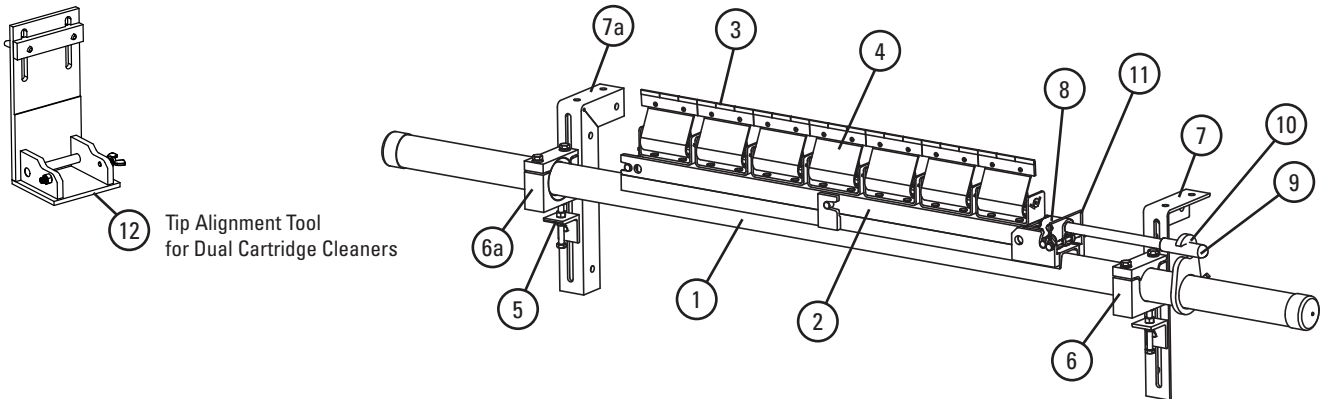

### Replacement Parts

REF	DESCRIPTION	ORDERING NUMBER	ITEM CODE	WT. KG
1	SAC Cartridge Pole 600mm	SACPL-24/600	77887	29.7
	SAC Cartridge Pole 750mm	SACPL-30/750	77888	32.3
	SAC Cartridge Pole 900mm	SACPL-36/900	77889	35.0
	SAC Cartridge Pole 1050mm	SACPL-42/1050	77890	37.6
	SAC Cartridge Pole 1200mm	SACPL-48/1200	77891	40.3
	SAC Cartridge Pole 1350mm	SACPL-54/1350	77892	42.9
	SAC Cartridge Pole 1500mm	SACPL-60/1500	77893	45.6
	SAC Cartridge Pole 1800mm	SACPL-72/1800	77894	50.9
	SAC Cartridge Center Pole 1500mm (Dual)	SACPL2-60/1500	77895	35.1
	SAC Cartridge Center Pole 1800mm (Dual)	SACPL2-72/1800	77896	40.6
	SAC Cartridge Center Pole 2100mm (Dual)	SACPL2-84/2100	77897	46.2
	SAC Cartridge Center Pole 2400mm (Dual)	SACPL2-96/2400	77898	51.8
	SAC Cartridge Center Pole 3000mm (Dual)	SACPL2-120/3000	77899	64.5
	1a	Extender Pole (for use with Dual Cartridge Center Pole)	MHP-EP	76392
2	SAC Repl Cartridge S/S 600mm	CART-24/600-S/S	78576	4.5
	SAC Repl Cartridge S/S 750mm	CART-30/750-S/S	78577	5.6
	SAC Repl Cartridge S/S 900mm	CART-36/900-S/S	78578	6.7
	SAC Repl Cartridge S/S 1050mm	CART-42/1050-S/S	78579	7.8
	SAC Repl Cartridge S/S 1200mm	CART-48/1200-S/S	78580	8.9
	SAC Repl Cartridge S/S 1350mm	CART-54/1350-S/S	78581	10.0
	SAC Repl Cartridge S/S 1500mm	CART-60/1500-S/S	78582	11.3
	SAC Repl Cartridge S/S 1800mm	CART-72/1800-S/S	78583	13.5
	SAC Repl Cartridge S/S 1500mm (Dual)	CART2-60/1500-S/S	78584	11.2
	SAC Repl Cartridge S/S 1800mm (Dual)	CART2-72/1800-S/S	78585	13.4
	SAC Repl Cartridge S/S 1950mm (Dual)	CART2-78/1950-S/S	78635	14.5
	SAC Repl Cartridge S/S 2100mm (Dual)	CART2-84/2100-S/S	78586	15.6
	SAC Repl Cartridge S/S 2400mm (Dual)	CART2-96/2400-S/S	78587	17.8
	SAC Repl Cartridge S/S 3000mm (Dual)	CART2-120/3000-S/S	78588	22.6

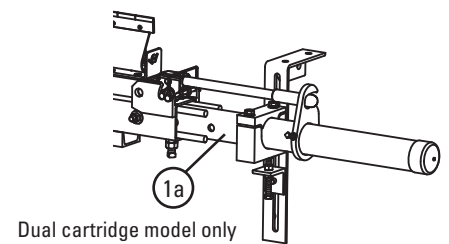

REF	DESCRIPTION	ORDERING NUMBER	ITEM CODE	WT. KG
3	V-Tip* (for vulcanised belts only)	RSA150	73628	0.4
	Extra Life R - V-Tip (15mm) (for vulcanised belts only)	RSA150-EL15	61141	0.4
	Extra Life R - V-Tip (20mm) (for vulcanised belts only)	RSA150-XL	67776	0.7
4	PowerFlex™ Cushion*	SPFC	79200	0.9
5	P/R Adjusting Bracket	PAB	75513	0.4
6	Cradle Clamp Block RH	SMR-CCB-R73	A2843	1.2
6a	Cradle Clamp Block LH	SMR-CCB-L73	A2842	1.2
7	Mounting Bracket Kit RH	PMBR	75519	3.8
7a	Mounting Bracket Kit LH	PMBL	75516	3.8
8	SAC Removal Knuckle	SACRKN	77882	1.5
9	SAC Removal Handle	SACRH	77883	1.4
10	SAC Handle Lock Plate	SACRHL	77884	0.8
11	Knuckle Retainer Pin	SACKRP	77885	0.1
-	SAC Removal Kit (incl. 1 ea. items 8,9,10,11)	SACRKT	77886	4.1
12	SAC Cartridge Tip Alignment Tool (Dual)	SAC2-TIP-TL	77866	1.1
-	Cradle Clamp Heavy-Duty Mounting Kit (incl. 2 ea. item 5; 1 ea. items 6, 6a, 7, 7a)	CRHMK	62400	10.8

Stock items (non-shaded) refer to (\*) for specific lead time, if not specified, standard lead time applies.  
Non-stock items (shaded) please contact Flexco for dispatch options and lead times.

# Replacement Parts List

## MHS SAC BT (Stainless Steel) HD<sup>®</sup> Secondary Cleaner with Service Advantage Cartridge™ & Bolt Tensioner

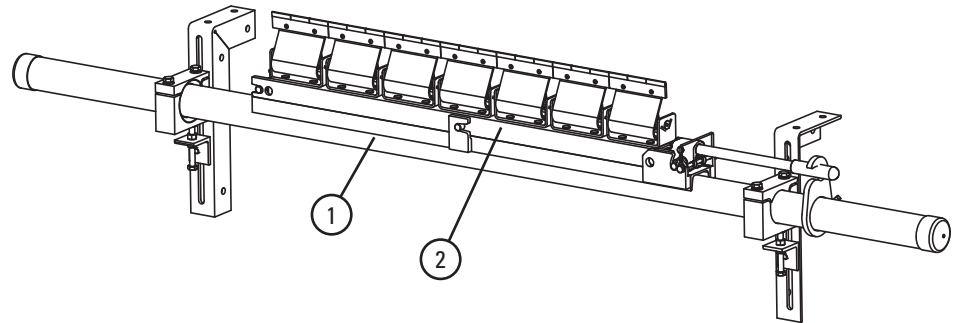

### Replacement Parts

REF	DESCRIPTION	ORDERING NUMBER	ITEM CODE	WT. KG
1	SAC S/S Cartridge Pole 600mm	SACPL-24/600-S/S	78371	29.7
	SAC S/S Cartridge Pole 750mm	SACPL-30/750-S/S	78372	32.3
	SAC S/S Cartridge Pole 900mm	SACPL-36/900-S/S	78373	35.0
	SAC S/S Cartridge Pole 1050mm	SACPL-42/1050-S/S	78374	37.6
	SAC S/S Cartridge Pole 1200mm	SACPL-48/1200-S/S	78375	40.3
	SAC S/S Cartridge Pole 1350mm	SACPL-54/1350-S/S	78376	42.9
	SAC S/S Cartridge Pole 1500mm	SACPL-60/1500-S/S	78377	45.6
	SAC S/S Cartridge Pole 1800mm	SACPL-72/1800-S/S	78378	50.9
	SAC S/S Cartridge Center Pole 1500mm (Dual)	SACPL2-60/1500-S/S	78379	35.1
	SAC S/S Cartridge Center Pole 1800mm (Dual)	SACPL2-72/1800-S/S	78380	40.6
	SAC S/S Cartridge Center Pole 1950mm (Dual)	SACPL2-78/1950-S/S	78642	43.9
	SAC S/S Cartridge Center Pole 2100mm (Dual)	SACPL2-84/2100-S/S	78381	46.2
	SAC S/S Cartridge Center Pole 2400mm (Dual)	SACPL2-96/2400-S/S	78382	51.8
	SAC S/S Cartridge Center Pole 3000mm (Dual)	SACPL2-120/3000-S/S	78383	64.5
1a	S/S Extender Pole (for use with S/S Dual Cartridge Center Pole)	MHP-EP-S/S	77599	24.5
2	SAC Repl Cartridge S/S 600mm	CART-24/600-S/S	78576	4.5
	SAC Repl Cartridge S/S 750mm	CART-30/750-S/S	78577	5.6
	SAC Repl Cartridge S/S 900mm	CART-36/900-S/S	78578	6.7
	SAC Repl Cartridge S/S 1050mm	CART-42/1050-S/S	78579	7.8
	SAC Repl Cartridge S/S 1200mm	CART-48/1200-S/S	78580	8.9
	SAC Repl Cartridge S/S 1350mm	CART-54/1350-S/S	78581	10.0
	SAC Repl Cartridge S/S 1500mm	CART-60/1500-S/S	78582	11.3
	SAC Repl Cartridge S/S 1800mm	CART-72/1800-S/S	78583	13.5

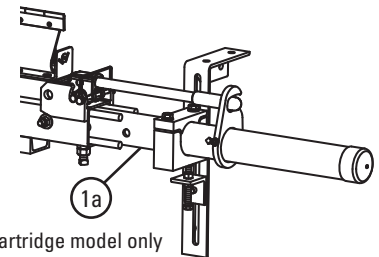

Dual cartridge model only

**Stock items** (non-shaded) refer to (\*) for specific lead time, if not specified, standard lead time applies.  
 **Non-stock items** (shaded) please contact Flexco for dispatch options and lead times.

# Replacement Parts List

## MHS SAC BT (Stainless Steel) HD® Secondary Cleaner with Service Advantage Cartridge™ & Bolt Tensioner

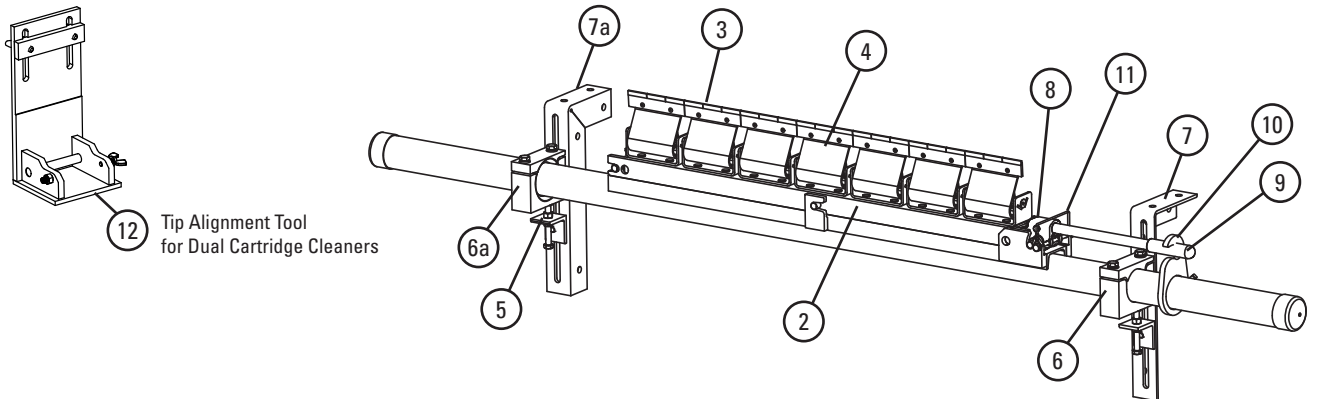

### Replacement Parts (Continued)

REF	DESCRIPTION	ORDERING NUMBER	ITEM CODE	WT. KG
2	SAC Repl Cartridge S/S 1500mm (Dual)	CART2-60/1500-S/S	78584	11.2
	SAC Repl Cartridge S/S 1800mm (Dual)	CART2-72/1800-S/S	78585	13.4
	SAC Repl Cartridge S/S 1950mm (Dual)	CART2-78/1950-S/S	78635	14.5
	SAC Repl Cartridge S/S 2100mm (Dual)	CART2-84/2100-S/S	78586	15.6
	SAC Repl Cartridge S/S 2400mm (Dual)	CART2-96/2400-S/S	78587	17.8
	SAC Repl Cartridge S/S 3000mm (Dual)	CART2-120/3000-S/S	78588	22.6
3	S/S V-Tip* (for vulcanised belts only)	RVT6-S/S	76205	0.4
4	PowerFlex™ Cushion S/S*	SPFC-S/S	79201	0.9
5	P/R Adjusting Bracket S/S	PAB-S/S	75515	0.4
6	Cradle Clamp LH S/S CRDLBLK-LH	CRDLBLK-RH-S/S	A2825	1.2
6a	Cradle Clamp RH S/S CRDLBLK-RH	CRDLBLK-LH-S/S	A2826	1.2
7	Mounting Bracket Kit RH S/S	PMBR-S/S	75521	3.8
7a	Mounting Bracket Kit LH S/S	PMBL-S/S	75518	3.8
8	SAC Removal Knuckle	SACRKN	77882	1.5
9	SAC Removal Handle S/S	SACRH-S/S	78397	1.4
10	SAC Handle Lock Plate S/S	SACRHL-S/S	78398	0.8
11	Knuckle Retainer Pin S/S	SACKRP-S/S	78399	0.1
-	SAC Removal Kit S/S (includes 1 ea. items 8,9,10,11)	SACRKT-S/S	78401	4.1
12	SAC Cartridge Tip Alignment Tool (Dual)	SAC2-TIP-TL	77866	1.1
-	Cradle Clamp Stainless Steel Heavy-Duty Mounting Kit (incl. 2 ea. item 5; incl. 1 ea. items 6, 6a, 7, 7a)	CRHMK-S/S	62095	10.8

Stock items (non-shaded) refer to (\*) for specific lead time, if not specified, standard lead time applies.  
Non-stock items (shaded) please contact Flexco for dispatch options and lead times.

# Specifications & Guidelines

## MHS SAC BT HD® Secondary Cleaner with Service Advantage Cartridge™ & Bolt Tensioner

### Pole Length Specifications\*

VERSION	CLEANER SIZE	BLADE WIDTH	POLE LENGTH	MAXIMUM CONVEYOR SPAN
	mm	mm	mm	mm
Single	600	600	1950	1650
	750	750	2100	1800
	900	900	2250	1950
	1050	1050	2400	2100
	1200	1200	2550	2250
	1350	1350	2700	2400
	1500	1500	2850	2550
Dual	1800	1800	3150	2850
	1500	1500	3000	2700
	1800	1800	3300	3000
	2100	2100	3600	3300
	2400	2400	3900	3600
	3000	3000	4500	4200

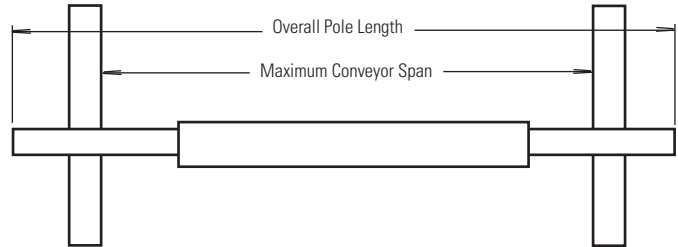

\*For special extra long pole length requirements a Pole Extender Kit (#76024) is available that provides 750 mm of extended pole length.  
Pole Diameter - 73 mm

### Clearance Guidelines for Installation

VERSION	HORIZONTAL CLEARANCE REQUIRED	VERTICAL CLEARANCE REQUIRED
	mm	mm
Single	114	279
Dual	114	318

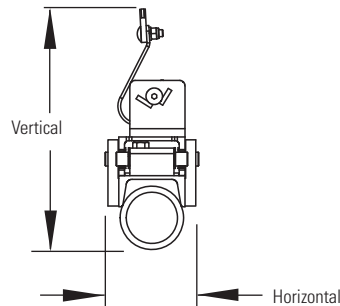

### Specifications:

- Maximum Belt Speed .....5 m/s
- Temperature Rating .....-35 to 82°C
- Usable Blade Wear Length.....9 mm
- Blade Materials .....C-Tip: Impact Resistant Tungsten Carbide (works with mechanical fasteners)  
V-Tip: Long Life Tungsten Carbide (for vulcanised belts only)
- Available for Belt Widths .....600 to 3000 mm. Other sizes available upon request.



# Product Ordering Information

## Spring Covers and Tensioner Lock

### Spring Covers

ORDERING NUMBER	ITEM CODE	WT. KG
SPG-CVR-A	77387	0.14
SPG-CVR-B	77388	0.14
SPG-CVR-C	77389	0.14
SPG-CVR-D	77390	0.18
SPG-CVR-E	77391	0.18
SPG-CVR-F	77392	0.14
SPG-CVR-G	77393	0.14
SPG-CVR-H	77741	0.14

Includes 1 spring cover

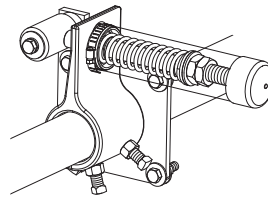
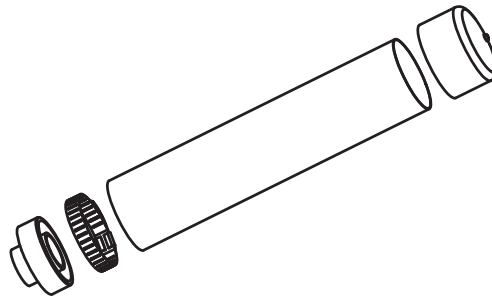

Spring cover on Primary Cleaner tensioner

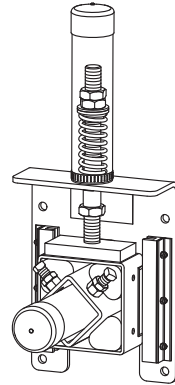

Spring cover on Secondary cleaner tensioner

### Tensioner Lock

Designed to prevent tampering or unauthorized retensioning of the cleaner.

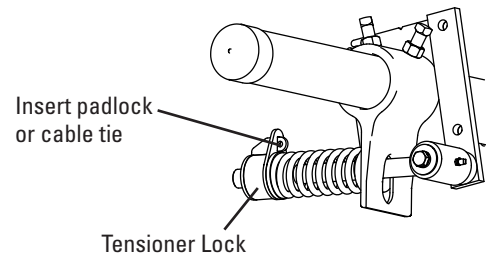
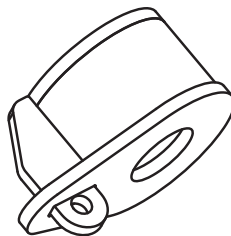

ORDERING NUMBER	ITEM CODE	WT. KG
TEN-LOCK-KIT	77443	0.18

\*For MSP, MMP, MHP, MHCP, H-Type® Primary Cleaners and MSS, MHS, MDWS Secondary Cleaners  
Includes 1 tensioner lock



Tensioner Lock

(Primary Cleaner tensioner shown)

 **Stock items** (non-shaded) refer to (\*) for specific lead time, if not specified, standard lead time applies.  
 **Non-stock items** (shaded) please contact Flexco for dispatch options and lead times.

# Product Ordering Information

## U-Type® Secondary Cleaner with USTensioner



### U-Type® with V-Blade (Tungsten Carbide)\* and USTensioner, Mild Steel

CLEANER COMPLETE				REPLACEMENT V-BLADE		
BELT WIDTH	ORDERING NUMBER	ITEM CODE	WT. KG	ORDERING NUMBER	ITEM CODE	WT. KG
mm						
450	UTV450	77297	38.4	URVB18/450	76736	2.3
600	UTV600	77298	41.3	URVB24/600	76737	3.1
750	UTV750	77299	43.9	URVB30/750	76738	3.8
900	UTV900	77300	46.6	URVB36/900	76739	4.6
1050	UTV1050	77301	49.1	URVB42/1050	76740	5.3
1200	UTV1200	77302	51.9	URVB48/1200	76741	5.7
1350	UTV1350	77303	54.3	URVB54/1350	76742	6.8
1400	UTV1400	77304	55.1	URVB56/1400	77314	7.1
1500	UTV1500	77305	57.0	URVB60/1500	76743	7.6
1600	UTV1600	77306	59.0	URVB64/1600	77315	8.1
1800	UTV1800	77307	71.6	URVB72/1800	76744	9.2
2000	UTV2000	77308	75.3	URVB80/2000	77320	10.2
2100	UTV2100	77309	78.4	URVB84/2100	76745	10.7
2200	UTV2200	77310	81.7	URVB88/2200	77316	11.2
2400	UTV2400	77411	84.6	URVB94/2400	77421	12.0
2500	UTV2500	77412	87.1	URVB98/2500	77422	12.5

\*NOTE: V-Blades (Tungsten Carbide) can be used on vulcanised belts and mechanically spliced belts ONLY IF the splice is skived (recessed into the belt's cover) (on solid plate splices the bolts must be ground).  
CAUTION: The V-Blade CANNOT be used on belts with mechanical rip repair fasteners.

### U-Type® with V-Blade (Tungsten Carbide)\* and USTensioner, Stainless Steel

CLEANER COMPLETE				REPLACEMENT V-BLADE		
BELT WIDTH	ORDERING NUMBER	ITEM CODE	WT. KG	ORDERING NUMBER	ITEM CODE	WT. KG
mm						
450	UTV450-S/S	82707	17.0	URVB18/450	76736	2.3
600	UTV600-S/S	82708	18.2	URVB24/600	76737	3.1
750	UTV750-S/S	82709	19.6	URVB30/750	76738	3.8
900	UTV900-S/S	82710	21.7	URVB36/900	76739	4.6
1050	UTV1050-S/S	82711	23.1	URVB42/1050	76740	5.3
1200	UTV1200-S/S	82712	26.0	URVB48/1200	76741	5.7
1350	UTV1350-S/S	82713	27.7	URVB54/1350	76742	6.8
1400	UTV1400-S/S	82714	28.7	URVB56/1400	77314	7.1
1500	UTV1500-S/S	82715	31.0	URVB60/1500	76743	7.6
1600	UTV1600-S/S	82716	32.9	URVB64/1600	77315	8.1
1800	UTV1800-S/S	82717	36.4	URVB72/1800	76744	9.2
2000	UTV2000-S/S	82718	39.0	URVB80/2000	77320	10.2
2100	UTV2100-S/S	82719	41.7	URVB84/2100	76745	10.7
2200	UTV2200-S/S	82720	44.4	URVB88/2200	77316	11.2
2400	UTV2400-S/S	82721	47.1	URVB94/2400	77421	12.0
2500	UTV2500-S/S	82722	49.8	URVB98/2500	77422	12.5

\*NOTE: V-Blades (Tungsten Carbide) can be used on vulcanised belts and mechanically spliced belts ONLY IF the splice is skived (recessed into the belt's cover) (on solid plate splices the bolts must be ground).  
CAUTION: The V-Blade CANNOT be used on belts with mechanical rip repair fasteners.

Stock items (non-shaded) refer to (\*) for specific lead time, if not specified, standard lead time applies.  
Non-stock items (shaded) please contact Flexco for dispatch options and lead times.

# Product Ordering Information

## U-Type® Secondary Cleaner with J-Bolt Tensioner

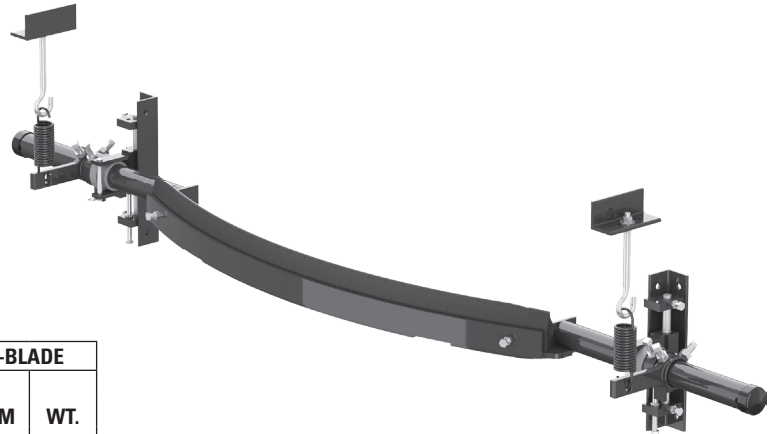

### U-Type® with V-Blade (Tungsten Carbide)\* and J-Bolt Tensioner, Mild Steel

CLEANER COMPLETE				REPLACEMENT V-BLADE		
BELT WIDTH	ORDERING NUMBER	ITEM CODE	WT. KG	ORDERING NUMBER	ITEM CODE	WT. KG
mm						
450	UTV450-J	77283	37.3	URVB18/450	76736	2.3
600	UTV600-J	77284	40.0	URVB24/600	76737	3.1
750	UTV750-J	77285	43.2	URVB30/750	76738	3.8
900	UTV900-J	77286	47.7	URVB36/900	76739	4.6
1050	UTV1050-J	77287	50.9	URVB42/1050	76740	5.3
1200	UTV1200-J	77288	57.3	URVB48/1200	76741	5.7
1350	UTV1350-J	77289	60.9	URVB54/1350	76742	6.8
1400	UTV1400-J	77290	63.2	URVB56/1400	77314	7.1
1500	UTV1500-J	77291	68.2	URVB60/1500	76743	7.6
1600	UTV1600-J	77292	72.3	URVB64/1600	77315	8.1
1800	UTV1800-J	77293	80.0	URVB72/1800	76744	9.2
2000	UTV2000-J	77294	85.9	URVB80/2000	77320	10.2
2100	UTV2100-J	77295	91.8	URVB84/2100	76745	10.7
2200	UTV2200-J	77296	97.7	URVB88/2200	77316	11.2
2400	UTV2400-J	77413	103.6	URVB94/2400	77421	12.0
2500	UTV2500-J	77414	109.6	URVB98/2500	77422	12.5

\*NOTE: V-Blades (Tungsten Carbide) can be used on vulcanised belts and mechanically spliced belts ONLY IF the splice is skived (recessed into the belt's cover) (on solid plate splices the bolts must be ground).

CAUTION: The V-Blade CANNOT be used on belts with mechanical rip repair fasteners.

### U-Type® with V-Blade (Tungsten Carbide)\* and J-Bolt Tensioner, Stainless Steel

CLEANER COMPLETE				REPLACEMENT V-BLADE		
BELT WIDTH	ORDERING NUMBER	ITEM CODE	WT. KG	ORDERING NUMBER	ITEM CODE	WT. KG
mm						
450	UTV450J-S/S	77259	37.3	URVB18/450	76736	2.3
600	UTV600J-S/S	77260	40.0	URVB24/600	76737	3.1
750	UTV750J-S/S	77261	43.2	URVB30/750	76738	3.8
900	UTV900J-S/S	77262	47.7	URVB36/900	76739	4.6
1050	UTV1050J-S/S	77263	50.9	URVB42/1050	76740	5.3
1200	UTV1200J-S/S	77264	57.3	URVB48/1200	76741	5.7
1350	UTV1350J-S/S	77265	60.9	URVB54/1350	76742	6.8
1400	UTV1400J-S/S	77266	63.2	URVB56/1400	77314	7.1
1500	UTV1500J-S/S	77267	68.2	URVB60/1500	76743	7.6
1600	UTV1600J-S/S	77268	72.3	URVB64/1600	77315	8.1
1800	UTV1800J-S/S	77269	80.0	URVB72/1800	76744	9.2
2000	UTV2000J-S/S	77270	85.9	URVB80/2000	77320	10.2
2100	UTV2100J-S/S	77271	91.8	URVB84/2100	76745	10.7
2200	UTV2200J-S/S	77272	97.7	URVB88/2200	77316	11.2
2400	UTV2400J-S/S	77417	103.6	URVB94/2400	77421	12.0
2500	UTV2500J-S/S	77418	109.6	URVB98/2500	77422	12.5

\*NOTE: V-Blades (Tungsten Carbide) can be used on vulcanised belts and mechanically spliced belts ONLY IF the splice is skived (recessed into the belt's cover) (on solid plate splices the bolts must be ground).

CAUTION: The V-Blade CANNOT be used on belts with mechanical rip repair fasteners.

**Stainless Steel U-Type with C or F blade available by special order**

- Stock items (non-shaded) refer to (\*) for specific lead time, if not specified, standard lead time applies.
- Non-stock items (shaded) please contact Flexco for dispatch options and lead times.

# Replacement Parts List

## U-Type® Secondary Cleaner with UST Tensioner or J-Bolt Tensioner

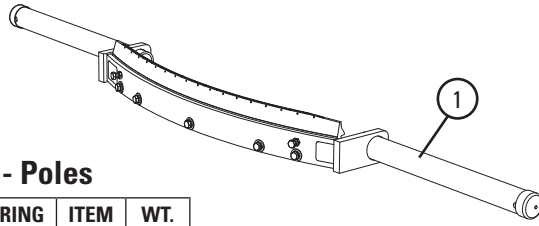

### Replacement Parts - Poles

REF	DESCRIPTION	ORDERING NUMBER	ITEM CODE	WT. KG
1	450mm Pole	USP18/450	82689	18.6
	600mm Pole	USP24/600	82690	20.1
	750mm Pole	USP30/750	82691	21.6
	900mm Pole	USP36/900	82692	23.2
	1050mm Pole	USP42/1050	82693	24.8
	1200mm Pole	USP48/1200	82694	26.3
	1350mm Pole	USP54/1350	82695	27.9
	1400mm Pole	USP56/1400	82696	28.4
	1500mm Pole	USP60/1500	82697	29.5
	1600mm Pole	USP64/1600	82698	30.5
	1800mm Pole	USP72/1800	82699	32.6
	2000mm Pole	USP80/2000	82700	34.6
	2100mm Pole	USP84/2100	82701	35.7
	2200mm Pole	USP88/2200	82702	36.7
	2400mm Pole	USP94/2400	82703	38.3
2500mm Pole	USP98/2500	82704	39.4	

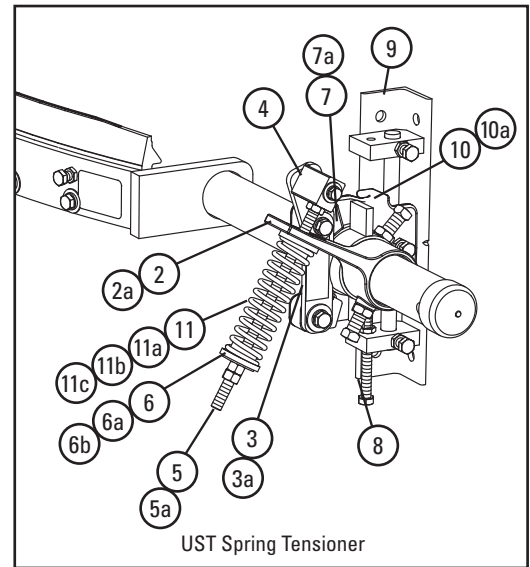

### Replacement Parts - UST Tensioner

REF	DESCRIPTION	ORDERING NUMBER	ITEM CODE	WT. KG
2	Torque Arm Kit (1 ea.)	ESTAK	76406	1.6
2a	Torque Arm Kit HD (1 ea.)	C-PSTA	81045	5.2
3	Pivot Shaft Bracket Kit (1 ea.)	MUPSBK	82896	0.8
3a	Pivot Shaft Bracket Kit HD (1 ea.)	QMTPSBK-CN	82182	2.0
4	Pivot Block Kit (1 ea.)	MESPBL	87895	0.5
5	Pivot Rod Kit (1 ea.)	MESPKR	81896	0.5
5a	Pivot Rod Kit HD (1 ea.)	PTPK-MT	82343	2.0
6	EST Bush Kit P&S MET	MESBK-PS	82364	0.05
6a	QMT Bush Kit W&S MET	QMTBK-WS-MT	82175	0.05
6b	QMT Bush Kit G MET	QMTBK-GCN	82174	0.05
7	Standard Pole Bearing (1 ea.)	USPB2	79206	0.05
7a	HD Pole Bearing (1 ea.)	UST	GN812	0.1
8	Adjusting Bolt Kit (1 ea. incl. lock nut)	ABU	76788	0.1
9	Mounting Bracket Kit (1 ea. incl. L & R)	UMBK-M	82890	4.4
10	Slide Plate Kit (1 ea.)	USPK	76790	2.1
10a	HD Slide Plate Kit (1 ea.)	UHSPK-M	82887	2.4
11	Tension Spring Purple (1 ea.)	QMTS-P	75845	0.3
11a	Tension Spring Silver (1 ea.)	ESS-S	76412	0.5
11b	Tension Spring White (1 ea.)	PSTS-W	75898	0.8
11c	Tension Spring Gold (1 ea.)	QMTS-G	76484	0.8
-	UST Spring Tensioner Mounting Kit* - Purple (Incl. 1 ea. Items 2, 3, 4, 5, 6, 8, 9, 10 & 11)	UST-P-MT	82897	9.5
-	UST Spring Tensioner Mounting Kit* - Silver (Incl. 1 ea. Items 2a, 4, 5a, 6a, 8, 9, 10a & 11a)	UST-S-MT	82898	13.1
-	Heavy-Duty UST Spring Tensioner* - White (Incl. 1 ea. Items 2a, 4, 5a, 6a, 8, 9, 10a & 11b)	UST-W-MT	82899	16.7
-	Heavy-Duty UST Spring Tensioner* - Gold (Incl. 1 ea. Items 2a, 4, 5a, 6a, 8, 9, 10a & 11c)	UST-G-MT	82900	16.7

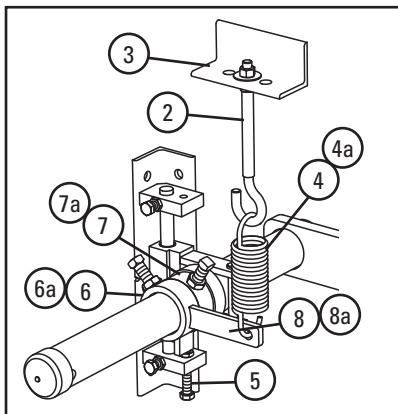

For use in changing UST Spring Tensioner to a J-Bolt Tensioner

### Replacement Parts - J-bolt Tensioner

REF	DESCRIPTION	ORDERING NUMBER	ITEM CODE	WT. KG
2	J-Bolt Kit* (incl. locknut and washer)	STJK	74417	0.3
3	J-Bolt Mount (1 ea.)	STJM	74775	1.4
4	450-1500mm Tension Spring (1 ea.)	STTS	74419	0.5
4a	1600mm+ Tension Spring (1 ea.)	HDTS	74502	0.7
5	Adjusting Bolt Kit (incl. locknut)	ABU	76788	0.5
6	450-1500mm UHMW Bearing (1 ea.)	USPB	79206	0.5
6a	1600mm+ UHMW Bearing (1 ea.)	UHPB	79207	0.5
7	450-1500mm Stop Collar* (1 ea.)	SCU60	82812	0.9
7a	1600mm+ Stop Collar* (1 ea.)	SCUHD	82813	0.9
8	450-1500mm Adjusting Arm* (1 ea.)	HARK	76406	0.9
8a	1600mm+ Adjusting Arm* (1 ea.)	HDARK	77329	0.9
-	450-1500mm Mounting Kit* (incl. 2 of items 2, 3, 4, 5, 6, 7, 8, 9 & incl. 1 of Item 5)	MMKU	77324	18.2
-	1600mm+ Mounting Kit* (incl. 2 of items 2, 3, 4a, 6, 7a, 8a, 9a & incl 1 of item 5)	MMKUHD	77327	19.6

\*Hardware included

\*Hardware included

**Note:** For belt widths equal to and larger than 1600 mm use heavy-duty components.

Stock items (non-shaded) refer to (\*) for specific lead time, if not specified, standard lead time applies.  
Non-stock items (shaded) please contact Flexco for dispatch options and lead times.

# Replacement Parts List

## Stainless Steel U-Type® Secondary Cleaner with UST Tensioner or J-Bolt Tensioner

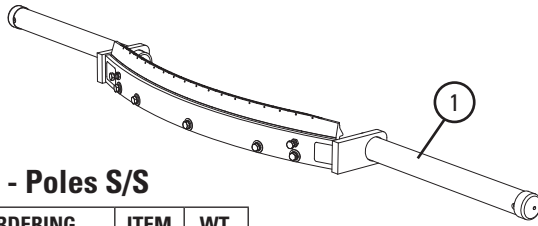

### Replacement Parts - Poles S/S

REF	DESCRIPTION	ORDERING NUMBER	ITEM CODE	WT. KG
1	450mm Pole	USP18/450-S/S	77339	18.6
	600mm Pole	USP24/600-S/S	77340	20.1
	750mm Pole	USP30/750-S/S	77341	21.6
	900mm Pole	USP36/900-S/S	77342	23.2
	1050mm Pole	USP42/1050-S/S	77343	24.8
	1200mm Pole	USP48/1200-S/S	77344	26.3
	1350mm Pole	USP54/1350-S/S	77345	27.9
	1400mm Pole	USP56/1400-S/S	77346	28.4
	1500mm Pole	USP60/1500-S/S	77347	29.5
	1600mm Pole	USP64/1600-S/S	77348	30.5
	1800mm Pole	USP72/1800-S/S	77349	32.6
	2000mm Pole	USP80/2000-S/S	77350	34.6
	2100mm Pole	USP84/2100-S/S	77351	35.7
	2200mm Pole	USP88/2200-S/S	77352	36.7
	2400mm Pole	USP94/2400-S/S	77419	38.3
2500mm Pole	USP98/2500-S/S	77420	39.4	

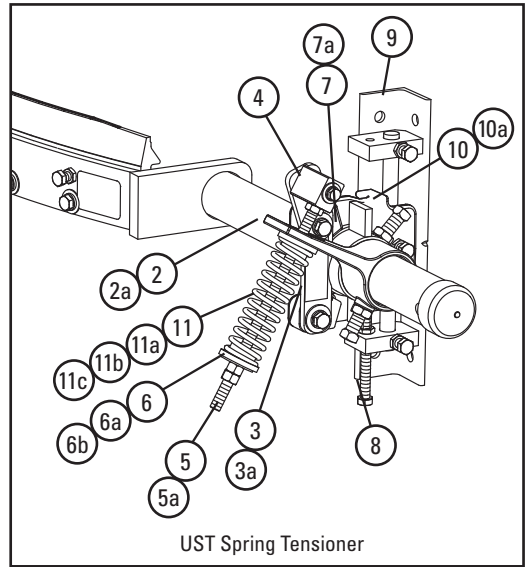

### Replacement Parts - UST Tensioner S/S

REF	DESCRIPTION	ORDERING NUMBER	ITEM CODE	WT. KG
2	Torque Arm Kit (1 ea.)	ESTAK-SS	78849	1.6
2a	Torque Arm Kit HD (1 ea.)	MPSTA-S/S	82289	5.2
3	Pivot Shaft Bracket Kit (1 ea.)	MUPSBK-SS	82893	0.8
3a	Pivot Shaft Bracket Kit HD (1 ea.)	MQMTSBK-SS	82895	2.0
4	Pivot Block Kit (1 ea.)	MESPBL-SS	82892	0.5
5	Pivot Rod Kit (1 ea.)	MESPKR-SS	82894	0.5
5a	Pivot Rod Kit HD (1 ea.)	PTPK-MT-S/S	82342	2.0
6	EST Bush Kit P&S MET	MESBK-PS	82364	0.05
6a	QMT Bush Kit W&S MET	QMTBK-WS-MT	82175	0.05
6b	QMT Bush Kit G MET	QMTBK-GCN	82174	0.05
7	Standard Pole Bearing (1 ea.)	USPB2	79206	0.05
7a	HD Pole Bearing (1 ea.)	UST	GN812	0.1
8	Adjusting Bolt Kit (1 ea. incl. lock nut)	ABU	76788	0.1
9	Mounting Bracket Kit (1 ea. incl. L & R)	UMBK-SS-M	82891	4.4
10	Slide Plate Kit (1 ea.)	USPK-SS-M	82888	2.1
10a	HD Slide Plate Kit (1 ea.)	UHSPK-SS-M	82889	2.4
11	Tension Spring Purple (1 ea.)	QMTS-P-SS	77450	0.3
11a	Tension Spring Silver (1 ea.)	ESS-S-S/S	79288	0.5
11b	Tension Spring White (1 ea.)	QMTS-W-SS	77451	0.8
11c	Tension Spring Gold (1 ea.)	QMTS-G-SS	77452	0.8
-	UST Spring Tensioner Mounting Kit* - Purple (Incl. 1 ea. Items 2, 3, 4, 5, 6, 8, 9, 10 & 11) (for belt widths 450-1050mm)	UST-P-MT-SS	82901	9.5
-	UST Spring Tensioner Mounting Kit* - Silver (Incl. 1 ea. Items 2a, 4, 5a, 6a, 8, 9, 10a & 11a) (for belt widths 1200-1500mm)	UST-S-MT-SS	82902	13.1
-	Heavy-Duty UST Spring Tensioner* - White (Incl. 1 ea. Items 2a, 4, 5a, 6a, 8, 9, 10a & 11b) (for belt widths 1800-2400mm)	UST-W-MT-SS	82903	16.7
-	Heavy-Duty UST Spring Tensioner* - Gold (Incl. 1 ea. Items 2a, 4, 5a, 6a, 8, 9, 10a & 11c) (for belt widths over 2400mm)	UST-G-MT-SS	82904	16.7

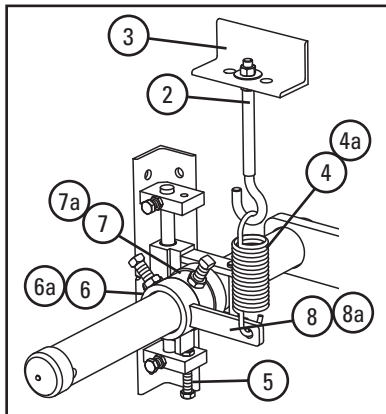

For use in changing UST Spring Tensioner to a J-Bolt Tensioner

### Replacement Parts - J-bolt Tensioner S/S

REF	DESCRIPTION	ORDERING NUMBER	ITEM CODE	WT. KG
2	J-Bolt Kit* (incl. locknut and washer)	STJK-S/S	77334	0.3
3	J-Bolt Mount (1 ea.)	STJ-S/S	75426	1.4
4	450-1500mm Tension Spring (1 ea.)	STTS-S/S	75585	0.5
4a	1600mm+ Tension Spring (1 ea.)	HDTS-S/S	75586	0.7
5	Adjusting Bolt Kit (incl. locknut)	ABU	76788	0.5
6	450-1500mm UHMW Bearing (1 ea.)	USPB	79206	0.5
6a	1600mm+ UHMW Bearing (1 ea.)	UHPB	79207	0.5
7	450-1500mm Stop Collar* (1 ea.)	SCU60-S/S	82810	0.9
7a	1600mm+ Stop Collar* (1 ea.)	SCUHD-S/S	82811	0.9
8	450-1500mm Adjusting Arm* (1 ea.)	HARK-S/S	77364	0.9
8a	1600mm+ Adjusting Arm* (1 ea.)	HDARK-S/S	77331	0.9
-	450-1500mm Mounting Kit* (incl. 2 of items 2, 3, 4, 5, 6, 7, 8, 9 & incl. 1 of item 5)	MMKU-SS	77357	18.2
-	1600mm+ Mounting Kit* (incl. 2 of items 2, 3, 4a, 6, 7a, 8a, 9a & incl. 1 of item 5)	MMKUHD-SS	77358	19.6

\*Hardware included

\*Hardware included

**Note:** For belt widths equal to and larger than 1600mm use heavy-duty components.

Stock items (non-shaded) refer to (\*) for specific lead time, if not specified, standard lead time applies.  
Non-stock items (shaded) please contact Flexco for dispatch options and lead times.

# Replacement Parts List

## U-Type® Secondary Cleaner with USTensioner

### U-Type® V-Blades (Tungsten Carbide)\*

BELT WIDTH	ORDERING NUMBER	ITEM CODE	WT. KG
mm			
450	URVB18/450	76736	2.3
600	URVB24/600	76737	3.1
750	URVB30/750	76738	3.8
900	URVB36/900	76739	4.6
1050	URVB42/1050	76740	5.3
1200	URVB48/1200	76741	6.1
1350	URVB54/1350	76742	6.8
1400	URVB56/1400	77314	7.1
1500	URVB60/1500	76743	7.6
1600	URVB64/1600	77315	8.1
1800	URVB72/1800	76744	9.2
2000	URVB80/2000	77320	10.2
2100	URVB84/2100	76745	10.7
2200	URVB88/2200	77316	11.2
2400	URVB94/2400	77421	12.0
2500	URVB98/2500	77422	12.5

\*NOTE: V-Blades (Tungsten Carbide) can be used on vulcanised belts. CAUTION: The V-Blade CANNOT be used on belts with mechanical rip repair fasteners. Use the F-Blade.

Replacement blades also available in FRAS. Contact Flexco® for more information.

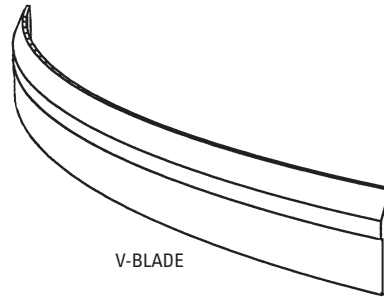

V-BLADE

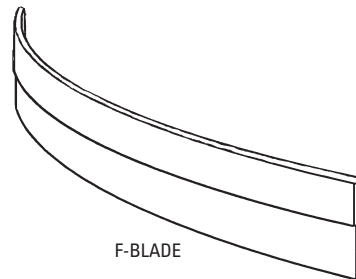

F-BLADE

### U-Type® F-Blades (Purple Polyurethane)\*

BELT WIDTH	ORDERING NUMBER	ITEM CODE	WT. KG
mm			
450	UFB18	74448	1.4
600	UFB24	74449	1.8
750	UFB30	74450	2.3
900	UFB36	74451	2.7
1050	UFB42	74452	3.2
1200	UFB48	74453	3.6
1350	UFB54	74454	4.1
1500	UFB60	74455	4.6
1800	UFB72	74456	5.5
2100	UFB84	74460	6.4

\*NOTE: F-Blades (Polyurethane) can be used on mechanically fastened belts and vulcanised belts.

### U-Type® F-Blades FRAS (Blue Polyurethane)\*

BELT WIDTH	ORDERING NUMBER	ITEM CODE	WT. KG
mm			
450	UFB18-B	67327	1.4
600	UFB24-B	67328	1.8
750	UFB30-B	67329	2.3
900	UFB36-B	67330	2.7
1050	UFB42-B	67331	3.2
1200	UFB48-B	67332	3.6
1350	UFB54-B	67333	4.1
1500	UFB60-B	67334	4.6
1800	UFB72-B	67335	5.5
2100	UFB84-B	67336	6.4

\*NOTE: F-Blades (Polyurethane) can be used on mechanically fastened belts and vulcanised belts.

Stock items (non-shaded) refer to (\*) for specific lead time, if not specified, standard lead time applies.  
Non-stock items (shaded) please contact Flexco for dispatch options and lead times.



# Specifications & Guidelines

## Pole Length Specifications

CLEANER SIZE	POLE LENGTH	MAXIMUM CONVEYOR SPAN
mm	mm	mm
450	1375	1125
600	1575	1325
750	1825	1575
900	1975	1925
1050	2125	1875
1200	2375	2125
1350	2525	2275
1500	2650	2400
1800	2950	2700

Pole Diameter - 450-1500mm cleaners: 60mm  
Pole Diameter - 1600mm+ cleaners: 75mm

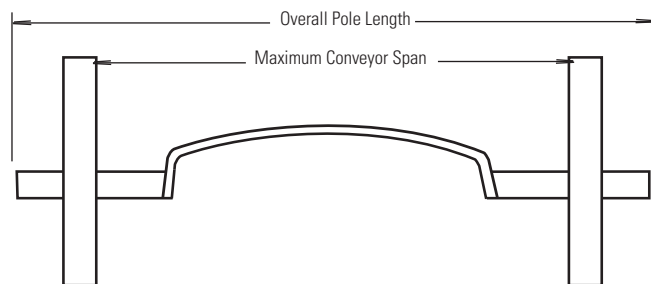

## Clearance Guidelines For Installation

BELT WIDTH/ CLEANER SIZE	CLEARANCE REQUIRED
mm	mm
450	140
600	166
750	191
900	171
1050	217
1200	242
1350	242
1500	242
1800	261
2100	261

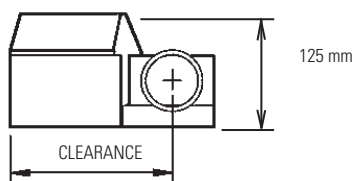

## Specifications:

- Maximum Belt Speed .....Contact Flexco
- Temperature Rating .....-35 to 82°C
- Usable Blade Wear Length.....V-Blade and C-Blade - 9 mm; F-Blade - 44 mm
- Available for Belt Widths .....450 to 2500 mm.  
Other sizes available upon request

## UST Spring Length Chart

Blade Width	Purple Springs	Silver Springs	White Springs
mm	mm	mm	mm
450	143	N/A	N/A
600	133	152	N/A
750	117	146	156
900	108	143	152
1050	N/A	133	146
1200	N/A	124	140
1350	N/A	117	137
1500	N/A	N/A	133
1800	N/A	N/A	124
2100	N/A	N/A	117

Shading indicates preferred spring option.

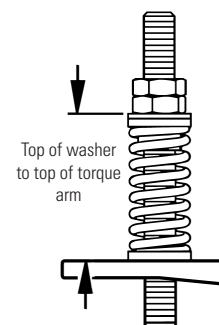

## Spring Tensioner Guidelines

(For Cleaners with J-Bolt Tensioners)

- Spring gap = .7 mm minimum
- Gauge provided

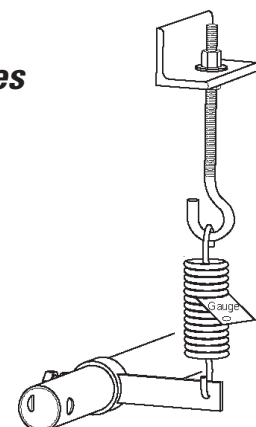



# Product Ordering Information

## MDWS Secondary Cleaner DryWipe for Removing Water

### MDWS Mild Steel Secondary Belt Cleaner with SST XD Tensioner

BELT WIDTH mm	ORDERING NUMBER	ITEM CODE	WT. KG
600	MDWS-24	75868	52.2
750	MDWS-30	75869	55.7
900	MDWS-36	75870	58.0
1050	MDWS-42	75871	62.7
1200	MDWS-48	75872	66.6
1350	MDWS-54	75873	70.1
1500	MDWS-60	75874	73.6
1800	MDWS-72	75875	80.6
2100	MDWS-84	76806	87.6
2400	MDWS-96	79063	94.7

Lead time: 4 weeks

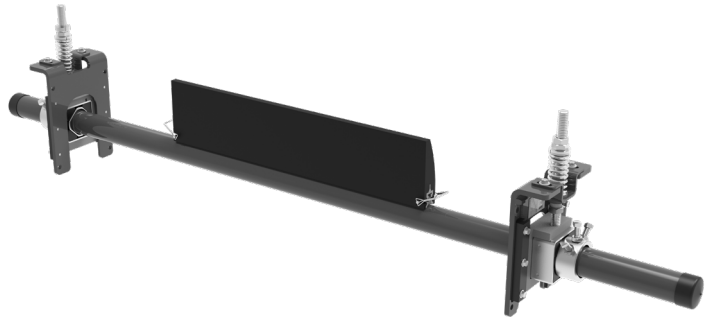

### MDWS Stainless Steel Secondary Belt Cleaner with SST XD Tensioner

BELT WIDTH mm	ORDERING NUMBER	ITEM CODE	WT. KG
600	MDWS-600-S/S	67466	52.5
750	MDWS-750-S/S	67467	56.0
900	MDWS-900-S/S	67468	58.3
1050	MDWS-1050-S/S	67469	63.0
1200	MDWS-1200-S/S	67470	67.0
1350	MDWS-1350-S/S	67471	70.5
1500	MDWS-1500-S/S	67472	74.0
1800	MDWS-1800-S/S	67473	81.1
2100	MDWS-2100-S/S	67474	88.1
2400	MDWS-2400-S/S	67475	95.3

Lead time: 4 weeks

### Product Notes:

- The ConShear™ “DryWipe” (DW) Blade is excellent for removing water from the belt. Use as the final cleaner in a cleaning system.
- Actual blade width is belt width plus 100 mm. The extra length ensures the water is removed from the belt.
- Pole Length: Belt width plus 1500 mm for cleaners up to 1500 mm, belt width plus 1350 mm for cleaners over 1500 mm.
- Visual Blade Tension Check: Measure the tension spring and refer to the Spring Length Chart on mounting base for the correct length for best cleaning performance.

Stock items (non-shaded) refer to (\*) for specific lead time, if not specified, standard lead time applies.  
 Non-stock items (shaded) please contact Flexco for dispatch options and lead times.

# Replacement Parts List

**MDWS**  
*Secondary Cleaner*  
*DryWipe for Removing Water*

## Replacement Poles

BELT WIDTH mm	MILD STEEL			STAINLESS STEEL		
	ORDERING NUMBER	ITEM CODE	WT. KG	ORDERING NUMBER	ITEM CODE	WT. KG
600	MSPP30	75804	46.0	MSPP30-S/S	77473	46.3
750	MSPP36	75805	50.5	MSPP36-S/S	77474	50.8
900	MSPP42	75806	55.5	MSPP42-S/S	77475	55.9
1050	MSPP48	75807	60.0	MSPP48-S/S	77476	60.4
1200	MSPP54	75808	64.0	MSPP54-S/S	77477	64.4
1350	MSPP60	75809	67.0	MSPP60-S/S	77478	67.4
1500	MSPP66	76695	76.0	MSPP66-S/S	77479	76.5
1800	DWP72	75883	90.0	DWP72-S/S	67409	90.6
2100	DWP84	76815	100.0	DWP84-S/S	67486	100.6
2400	DWP96	79060	116.0	DWP96-S/S	67487	110.7

## SST XD Replacement Parts

DESCRIPTION	MILD STEEL			STAINLESS STEEL		
	ORDERING NUMBER	ITEM CODE	WT. KG	ORDERING NUMBER	ITEM CODE	WT. KG
SST XD Mounting Base Kit* (includes 1 mounting base, 2 slide guides, top hat bracket & bottom bushing)	SSTXDMK	91412	4.6	STHDMK2-S/S	77634	4.6
Tension Spring - White (1 ea.) for belts 450–750mm	STS-W	75846	0.2	STS-W-S/S	77630	0.2
Tension Spring - Silver (1 ea.) for belts 900–1500mm	STS-S	75843	0.4	STS-S-S/S	77631	0.4
Tension Spring - Black (1 ea.) for belts 1800–2100mm	STS-B	75844	0.5	STS-B-S/S	77632	0.5
Tension Spring - Gold (1 ea.) for belts over 2100mm	STS-G	78142	0.7	STS-G-S/S	79057	0.5
SST Adj Rod Kit* (incl. 1 rod, 2 nuts, 2 bushings, 1 washer) for belts 450–1500mm	STAK	75847	1.3	STAK	75847	1.3
SST HD Adj Rod Kit* (incl. 1 rod, 2 nuts, 2 HD bushings, 1 washer) for belts 1800–2100mm	STAKHD	75892	1.4	STAKHD	75892	1.4
HD Torsion Pole Mount* (1 ea.)	SSTHDPM	77868	6.8	STHDPM2-S/S	77633	6.8
SST Bushing Kit - White/Silver	SSTBK-W	76636	0.1	SSTBK-W	76636	0.1
SST Bushing Kit - Black/Gold	SSTBK-B	76637	0.1	SSTBK-B	76637	0.1
SST Slide Guide Kit	STGK2	77635	0.5	STGK2	77635	0.5
SST HD Cartridge Tensioner - White (includes 1 ea. item 5, 9, 12, 14) for belts 450–750mm	SST1HDM-W	78517	13.7	SST1HDM-W-S/S	78394	13.7
SST HD Cartridge Tensioner - Silver (includes 1 ea. item 6, 9, 12, 14) for belts 900–1500mm	SST1HDM-S	78518	13.9	SST1HDM-S-S/S	78395	13.9
SST HD Cartridge Tensioner - Black (includes 1 ea. item 7, 10, 13, 14) for belts 1800–2100mm	SST1HDM-B	78519	14.1	SST1HDM-B-S/S	78396	14.1
SST HD Cartridge Tensioner - Gold (includes 1 ea. item 8, 10, 13, 14) for belts over 2100mm	SST1HDM-G	79069	14.3			
SST Hat Channel Kit	SSTHK	79582	0.7	SSTHK-S/S	79586	0.7

Refer to page 71 for reference image of spare parts.

# Replacement Parts List

**MDWS**  
**Secondary Cleaner**  
**DryWipe for Removing Water**

## ConShear™ DW Replacement Blades

BELT WIDTH	ORDERING NUMBER	ITEM CODE	WT. KG
mm			
600	CDWB24	75884	5.8
750	CDWB30	75885	7.0
900	CDWB36	75886	8.3
1050	CDWB42	75887	9.5
1200	CDWB48	75888	10.8
1350	CDWB54	75889	12.0
1500	CDWB60	75890	13.2
1800	CDWB72	75891	15.7
2100	CDWB84	76942	18.4
2400	CDWB96	79062	21.0

## Optional Mounting Kits

DESCRIPTION	ORDERING NUMBER	ITEM CODE	WT. KG
Blade Pin Kit (1 ea.)	MSPBP	107852	0.1
Spring Mounting kit	SST1HDM-S Cartridge Tensioner	78518	13.5
Replacement Spring SST	STS-S Tension Spring	75843	0.4
Replacement Bush SST Kit	SSTBK-W Bushing Kit (Pair)	76636	9.1

**Stock items** (non-shaded) refer to (\*) for specific lead time, if not specified, standard lead time applies.

**Non-stock items** (shaded) please contact Flexco for dispatch options and lead times.

# Specifications & Guidelines

## MDWS Secondary Cleaner DryWipe for Removing Water

CLEANER SIZE	BLADE WIDTH	POLE LENGTH	MAXIMUM CONVEYOR SPAN
mm	mm	mm	mm
600	700	2100	1700
750	850	2250	1850
900	1000	2400	2000
1050	1150	2550	2150
1200	1300	2700	2300
1350	1450	2850	2450
1500	1600	3000	2600
1800	1900	3150	2900
2100	2200	3450	3200
2400	2500	3750	3500

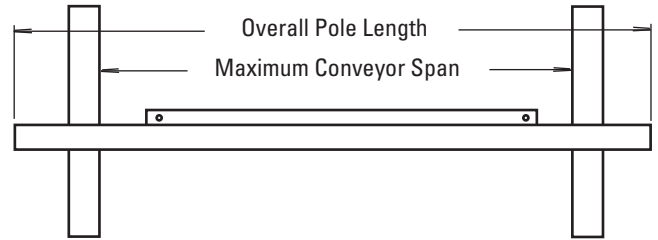

\*For special extra long pole length requirements a Pole Extender Kit (#76024) is available that provides 750mm (30") of extended pole length.  
Pole Diameter – 73mm (2-7/8")

### Clearance Guidelines for Installation

HORIZONTAL CLEARANCE REQUIRED	VERTICAL CLEARANCE REQUIRED
mm	mm
100	250

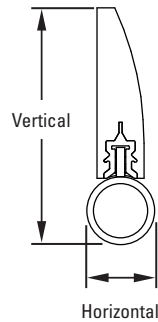

### SST XD Spring Length Chart

Blade Width	White Springs	Silver Springs	Black Springs	Gold Springs
mm	mm	mm	mm	mm
600	79	98	N/A	N/A
750	73	95	N/A	N/A
900	N/A	95	98	N/A
1050	N/A	92	95	N/A
1200	N/A	89	92	N/A
1350	N/A	86	92	95
1500	N/A	83	89	95
1800	N/A	N/A	86	92
2100	N/A	N/A	79	89
2400	N/A	N/A	N/A	86

Shading indicates preferred spring option.

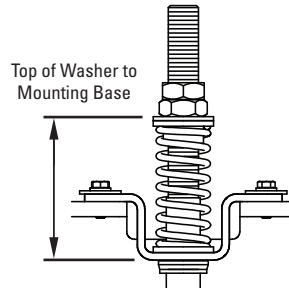

### Specifications:

- Maximum Belt Speed .....5m/s (1000 FPM)
- Temperature Rating .....-35 to 82°C
- Usable Blade Wear Length.....113 mm
- Blade Height.....185 mm
- Blade .....Polyurethane with UHMW additive (softer durometer to squeegee water off and additive to enhance blade life)
- Available for Belt Widths .....600 to 2400 mm  
Other sizes available upon request.
- CEMA Cleaner Rating .....Class 4

# Product Ordering Information

## Continuous Blade Secondary Cleaner

### Complete CBS w/ Bolt Tension - Standard Duty

	BELT WIDTH mm	MILD STEEL				STAINLESS STEEL			
		FLAT BLADE		CURVED BLADE		FLAT BLADE		CURVED BLADE	
		ORDERING NUMBER	ITEM CODE	ORDERING NUMBER	ITEM CODE	ORDERING NUMBER	ITEM CODE	ORDERING NUMBER	ITEM CODE
Standard Duty	450	CBS-450-BT	103244	CBSC-450-BT	108456	CBS-450-BT	106593	CBSC-450-BT	111963
	600	CBS-600-BT	103245	CBSC-600-BT	108457	CBS-600-BT	106594	CBSC-600-BT	111964
	750	CBS-750-BT	103246	CBSC-750-BT	108458	CBS-750-BT	106595	CBSC-750-BT	111965
	900	CBS-900-BT	103247	CBSC-900-BT	108459	CBS-900-BT	106596	CBSC-900-BT	111966
	1050	CBS-1050-BT	103248	CBSC-1050-BT	108460	CBS-1050-BT	106597	CBSC-1050-BT	111967
	1200	CBS-1200-BT	103249	CBSC-1200-BT	108461	CBS-1200-BT	106598	CBSC-1200-BT	111968
Heavy Duty	1350	CBS-1350-BT	103250	CBSC-1350-BT	108462	CBS-1350-BT	106599	CBSC-1350-BT	111969
	1500	CBSHD-1500-BT	103255	CBSCHD-1500-BT	108463	CBSHD-1500-BT	103259	CBSCHD-1500-BT	111970
	1800	CBSHD-1800-BT	103256	CBSCHD-1800-BT	108464	CBSHD-1800-BT	103260	CBSCHD-1800-BT	111971
	2100	CBSHD-2100-BT	103257	CBSCHD-2100-BT	108465	CBSHD-2100-BT	103261	CBSCHD-2100-BT	111972
	2400	CBSHD-2400-BT	103258	CBSCHD-2400-BT	108466	CBSHD-2400-BT	103262	CBSCHD-2400-BT	111973

Lead time: 3 weeks; for stocked items

### Complete CBS w/ SST XD Tension - Standard Duty

	BELT WIDTH mm	MILD STEEL				STAINLESS STEEL			
		FLAT BLADE		CURVED BLADE		FLAT BLADE		CURVED BLADE	
		ORDERING NUMBER	ITEM CODE	ORDERING NUMBER	ITEM CODE	ORDERING NUMBER	ITEM CODE	ORDERING NUMBER	ITEM CODE
Standard Duty	450	CBS18SF	79936	CBS18SC	91495	CBS18SF	111752	CBS18SC	111974
	600	CBS24SF	79937	CBS24SC	91496	CBS24SF	111753	CBS24SC	111975
	750	CBS30SF	79938	CBS30SC	91497	CBS30SF	111754	CBS30SC	111976
	900	CBS36SF	79939	CBS36SC	91498	CBS36SF	111755	CBS36SC	111977
	1050	CBS42SF	79940	CBS42SC	91499	CBS42SF	111756	CBS42SC	111978
	1200	CBS48SF	79941	CBS48SC	91500	CBS48SF	111757	CBS48SC	111979
Heavy Duty	1350	CBS54SF	79942	CBS54SC	91501	CBS54SF	111758	CBS54SC	111980
	1500	CBS60SF	84130	CBS60SC	108467	CBS60SF	102132	CBS60SC	111981
	1800	CBS72SF	84131	CBS72SC	108468	CBS72SF	102133	CBS72SC	111982
	2100	CBS84SF	84132	CBS84SC	108469	CBS84SF	102134	CBS84SC	111983
	2400	CBS96SF	84133	CBS96SC	108470	CBS96SF	102135	CBS96SC	111984

Lead time: 3 weeks; for stocked items

### Replacement Blades - CBS

BELT WIDTH mm	FLAT BLADE		CURVED BLADE		WT. KG.
	ORDERING NUMBER	ITEM CODE	ORDERING NUMBER	ITEM CODE	
450	CBSBLD18F	79947	CBSBLD18C	91527	7.3
600	CBSBLD24F	79948	CBSBLD24C	91528	10.0
750	CBSBLD30F	79949	CBSBLD30C	91529	12.3
900	CBSBLD36F	79950	CBSBLD36C	91530	15.0
1050	CBSBLD42F	79951	CBSBLD42C	91531	17.7
1200	CBSBLD48F	79952	CBSBLD48C	91532	20.4
1350	CBSBLD54F	79953	CBSBLD54C	91533	22.7
1500	CBSBLD60F	79954	CBSBLD60C	91534	25.4
1800	CBSBLD72F	79955	CBSBLD72C	91535	30.4
2100	CBSBLD84F	79956	CBSBLD84C	91536	35.8
2400	CBSBLD96F	79957	CBSBLD96C	91537	40.8

Lead time: 2 weeks; shaded items 12-14 weeks

### Product Notes:

- Heavy-duty design to deliver maximum cleaning efficiency on the most demanding, abusive beltlines.
- It is recommended that mechanical fasteners on the belt be skived.

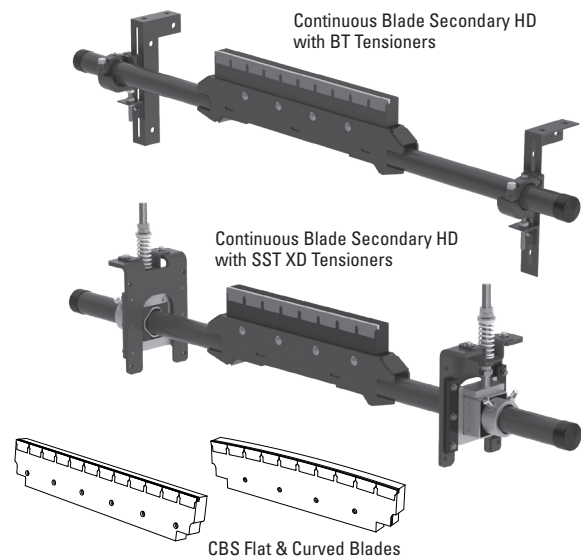

Stock items (non-shaded) refer to (\*) for specific lead time, if not specified, standard lead time applies.  
Non-stock items (shaded) please contact Flexco for dispatch options and lead times.

# Specifications and Guidelines

## Continuous Blade Secondary Cleaner

### Pole Length Specifications\*

CLEANER SIZE	BLADE WIDTH	POLE LENGTH	MAXIMUM CONVEYOR SPAN
mm	mm	mm	mm
450	450	1800	1550
600	600	1950	1700
750	750	2100	1850
900	900	2250	2000
1050	1050	2400	2150
1200	1200	2550	2300
1350	1350	2700	2450
1500	1500	2921	2600
1800	1800	3226	2900
2100	2100	3531	3200
2400	2400	3836	3500

\*For special extra long pole length requirements a Pole Extender Kit (#76024) is available that provides 750 mm of extended pole length. Pole Diameter - 73 mm

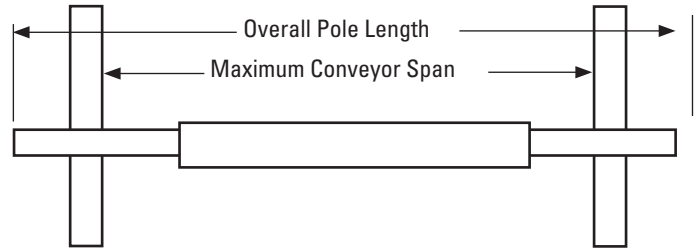

### Clearance Guidelines for Installation

CLEANER SIZE	HORIZONTAL CLEARANCE REQUIRED	VERTICAL CLEARANCE REQUIRED
mm	mm	mm
450 to 1350	115	250
1500 to 2400	165	240

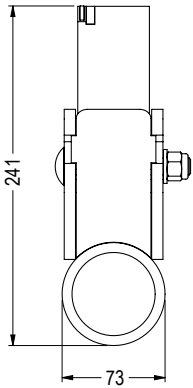
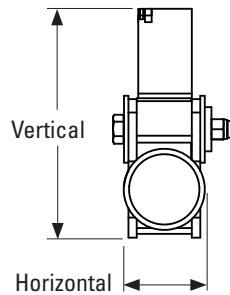

450–1350mm Belt Width

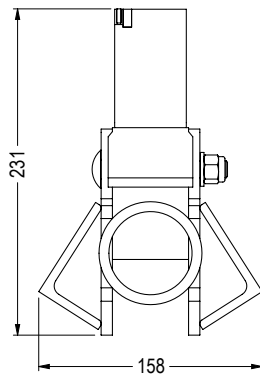

1500–2400mm Belt Width

### Specifications:

- Maximum Belt Speed .....4 m/s for mechanical fasteners  
6 m/s for vulcanized belts
- Temperature Rating .....-35 to 82°C
- Available for Belt Widths .....450 to 2400 mm. Other sizes available upon request.

# Replacement Parts

## Continuous Blade Secondary Cleaner

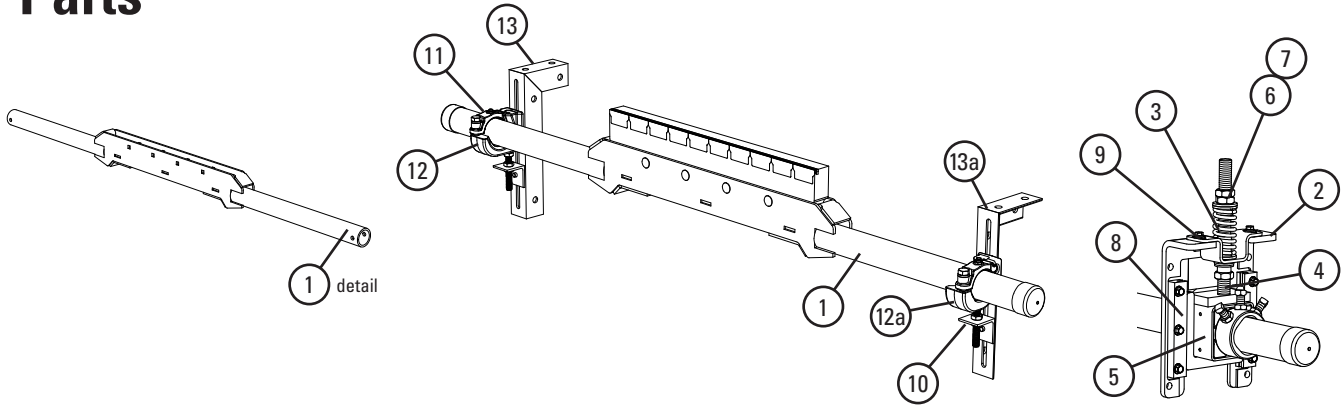

### Replacement Parts

REF	DESCRIPTION	BELT WIDTH mm	MILD STEEL				STAINLESS STEEL			
			FLAT BLADE		CURVED BLADE		FLAT BLADE		CURVED BLADE	
			ORDERING NUMBER	ITEM CODE	ORDERING NUMBER	ITEM CODE	ORDERING NUMBER	ITEM CODE	ORDERING NUMBER	ITEM CODE
1	CBS Pole (Ø73mm Diameter)	450	CBS450P	104413	CBS450P	104413	CBS450P-S/S	106569	CBS450P-S/S	106569
		600	CBS600P	104414	CBS600P	104414	CBS600P-S/S	106570	CBS600P-S/S	106570
		750	CBS750P	104415	CBS750P	104415	CBS750P-S/S	106571	CBS750P-S/S	106571
		900	CBS900P	104416	CBS900P	104416	CBS900P-S/S	106572	CBS900P-S/S	106572
		1050	CBS1050P	104417	CBS1050P	104417	CBS1050P-S/S	106573	CBS1050P-S/S	106573
		1200	CBS1200P	104418	CBS1200P	104418	CBS1200P-S/S	106574	CBS1200P-S/S	106574
	1350	CBS1350P	104419	CBS1350P	104419	CBS1350P-S/S	106575	CBS1350P-S/S	106575	
	CBS HD Pole (Ø73mm Diameter Extra Heavy)	1500	CBSHD-1500P	84086	CBSHD-1500P	84086	CBSHD-1500P	84116	CBSHD-1500P	84116
		1800	CBSHD-1800P	84087	CBSHD-1800P	84087	CBSHD-1800P	84117	CBSHD-1800P	84117
		2100	CBSHD-2100P	84088	CBSHD-2100P	84088	CBSHD-2100P	84118	CBSHD-2100P	84118
2400		CBSHD-2400P	84089	CBSHD-2400P	84089	CBSHD-2400P	84119	CBSHD-2400P	84119	

REF	DESCRIPTION	SPRING COLOUR	MILD STEEL		STAINLESS STEEL	
			SST XD TENSIONER			
			ORDERING NUMBER	ITEM CODE	ORDERING NUMBER	ITEM CODE
-	SST XD Spring Tensioner Kit (includes 1 ea. 2-9)	White	SSTXD-W	111782	SSTXD-W-S/S	111424
Silver		SSTXD-S	111783	SSTXD-S-S/S	111425	
Black		SSTXD-B	111784	SSTXD-B-S/S	111426	
Gold		SSTXD-G	111785	SSTXD-G-S/S	111427	
2	SST XD Mounting Base		SSTXDM	GR660	SSTXDM-S/S	109827
3	Tension Spring - White for belts 450-750mm		STS-W	75846	STS-W-S/S	77630
	Tension Spring - Silver for belts 750-1500mm		STS-S	75843	STS-S-S/S	77631
	Tension Spring - Black for belts 1800-2100mm		STS-B	75844	STS-B-S/S	77632
	Tension Spring - Gold for belts over 2100mm		STS-G	78142	STS-G-S/S	79057
4	SST Adj Rod Kit		STAKHD	75892	STAKHD	75892
5	SST XD Torsion Pole Mount		SSTHDPM	77868	SSTHDPM2-S/S	77633
6	SST Bushing Kit - White/Silver		SSTBK-W	76636	SSTBK-W	76636
7	SST Bushing Kit - Black/Gold		SSTBK-B	76637	SSTBK-B	76637
8	SST Slide Guide Kit		STGK2	77635	STGK2	77635
9	SST Hat Channel Kit		SSTHK	79582	SSTHK-S/S	79586
<b>BOLT TENSIONER</b>						
-	HD Bolt Tensioner Kits		CCMKHD	78920	CCMKHD-S/S	78922
10	Adjusting Bracket Kits		PAB	75513	PAB-S/S	75515
11	HD Cradle Clamp Top Strap		CCKHDTs	79233	CCKHDTs-S/S	79232
12	HD Pole Clamp Kit Left		CCKHDL	79225	CCKHDL-S/S	79227
12a	HD Pole Clamp Kit Right		CCKHDR	79229	CCKHDR-S/S	79231
13	Mounting Bracket - Left Hand		PMBL	75516	PMBL-S/S	75518
13a	Mounting Bracket - Right Hand		PMBR	75519	PMBR-S/S	75521

Stock items (non-shaded) refer to (\*) for specific lead time, if not specified, standard lead time applies.  
Non-stock items (shaded) please contact Flexco for dispatch options and lead times.



# Product Ordering Information

## Motorised Brush Cleaner

### Motorised Brush Cleaner

BELT WIDTH	ORDERING NUMBER	ITEM CODE	WT. KG
mm			
450	MBC-18	79494	62.1
600	MBC-24	79495	66.6
750	MBC-30	79496	68.3
900	MBC-36	79497	71.1
1050	MBC-42	79498	73.9
1200	MBC-48	79499	81.4
1350	MBC-54	79500	84.5
1500	MBC-60	79501	87.3
1800	MBC-72	79502	93.2
2100	MBC-84	79503	98.9



Motorised Brush Cleaner

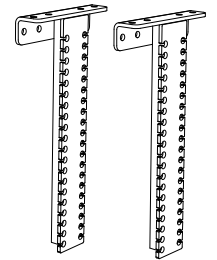

### Optional Mounting Brackets (Pair)

ORDERING NUMBER	ITEM CODE	WT. KG
MBCDBK	79536	13.1

### Replacement Brushes

BELT WIDTH	ORDERING NUMBER	ITEM CODE	WT. KG
mm			
450	MBRD-18	79514	4.35
600	MBRD-24	79515	6.12
750	MBRD-30	79516	7.76
900	MBRD-36	79517	9.30
1050	MBRD-42	79518	10.75
1200	MBRD-48	79519	12.15
1350	MBRD-54	79520	13.92
1500	MBRD-60	79521	15.37
1800	MBRD-72	79522	18.59
2100	MBRD-84	79523	21.54

### Product Notes:

- Spins opposite the belt direction for optimal cleaning.
- Uniquely patterned bristles aid in reducing material buildup and clogging.
- Adjustable tensioners allow easy brush-to-belt adjustment as the bristles wear.
- Works on mechanically spliced or vulcanised belts.
- Comes standard with IP55 but IP66 ingress protection option is available on request.

### Specifications:

- Maximum Belt Speed .....3.5 m/s
- Vertical and Horizontal Clearance.....305 mm
- Temperature Rating .....-30 to 82°C
- Maximum Chevron or Cleat Height .....13 mm
- Bristle Length.....83 mm
- Overall Diameter.....305 mm
- Shaft Length.....Belt Width plus 915 mm
- Shaft Diameter .....38 mm
- Motor HP.....1 HP cleaner 450–1050 mm  
2 HP cleaners 1200–2100 mm
- Motor Voltage .....230/400 V

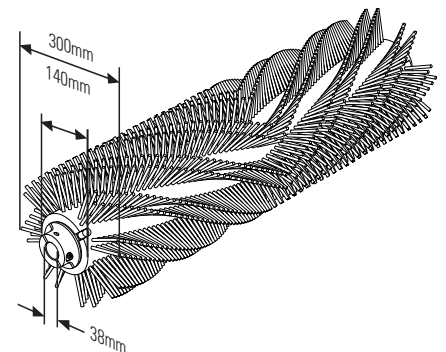
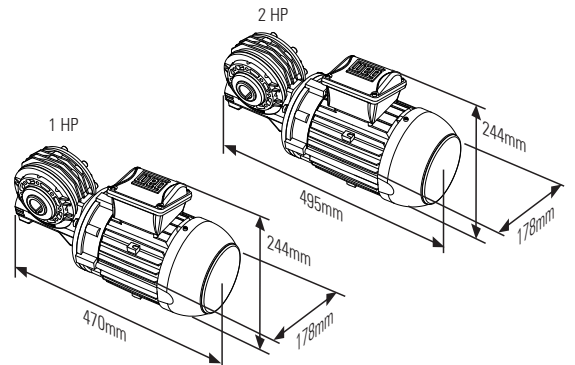

Stock items (non-shaded) refer to (\*) for specific lead time, if not specified, standard lead time applies.  
Non-stock items (shaded) please contact Flexco for dispatch options and lead times.

# Replacement Parts List

## Motorised Brush Cleaner

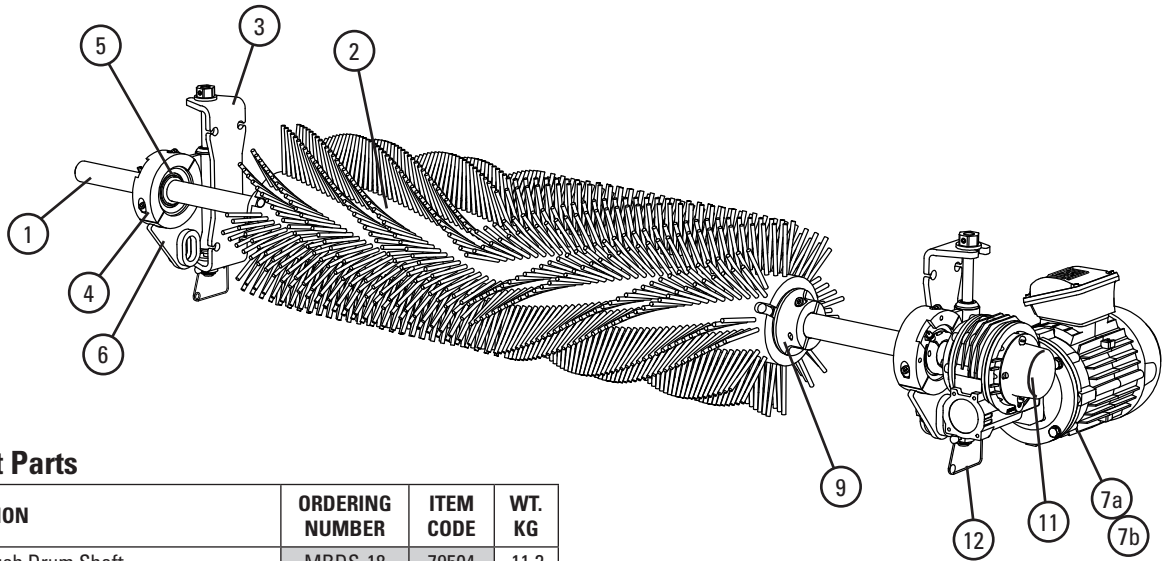

### Replacement Parts

REF	DESCRIPTION	ORDERING NUMBER	ITEM CODE	WT. KG
1	450mm Brush Drum Shaft	MBDS-18	79504	11.2
	600mm Brush Drum Shaft	MBDS-24	79505	12.5
	750mm Brush Drum Shaft	MBDS-30	79506	13.9
	900mm Brush Drum Shaft	MBDS-36	79507	15.3
	1050mm Brush Drum Shaft	MBDS-42	79508	16.6
	1200mm Brush Drum Shaft	MBDS-48	79509	18.0
	1350mm Brush Drum Shaft	MBDS-54	79510	19.3
	1500mm Brush Drum Shaft	MBDS-60	79511	20.7
	1800mm Brush Drum Shaft	MBDS-72	79512	23.4
	2100mm Brush Drum Shaft	MBDS-84	79513	26.1
2	450mm Replacement Brush Drum	MBRD-18	79514	4.4
	600mm Replacement Brush Drum	MBRD-24	79515	6.1
	750mm Replacement Brush Drum	MBRD-30	79516	7.8
	900mm Replacement Brush Drum	MBRD-36	79517	9.3
	1050mm Replacement Brush Drum	MBRD-42	79518	10.8
	1200mm Replacement Brush Drum	MBRD-48	79519	12.2
	1350mm Replacement Brush Drum	MBRD-54	79520	14.0
	1500mm Replacement Brush Drum	MBRD-60	79521	15.4
1800mm Replacement Brush Drum	MBRD-72	79522	18.6	
2100mm Replacement Brush Drum	MBRD-84	79523	21.6	
3	Brush Mounting Base* (1)	MBCMK	79524	2.1
4	Brush Bearing Clamp* (1)	MBCBC	79525	0.9
5	Brush Cleaner Bearings (2)	MBCB	79526	3.3
6	Brush Bearing Mount* (1)	MBCBM	79528	4.4
7a	Gearmotor Assy, 1 HP for belts up to 1050mm	MBCM-1	79529	25.0
7b	Gearmotor Assy, 2 HP for belts 1200mm and up	MBCM-2	79530	29.5
8	Brush Cleaner Torque Arm* (1)	MBCTA	79531	1.1
9	Brush Locks* (2)	MBCBL	79532	4.3
10	Brush Motor Key Kit (1)	MBCMCK	79533	0.1
11	MBC Shaft End Cap* (1)	MBCEC	79534	0.0
12	Tensioner Lock Pins (2)	STLP	79535	0.1
13	Brush Cleaner Drop Brackets* (2)	MBCDBK	79536	13.1
-	Brush Cleaner Adjusting Bracket (1) (incl. bearing and 1 ea. items 3, 4, 6 & 12)	MBADB	79527	8.2

\*Hardware Included

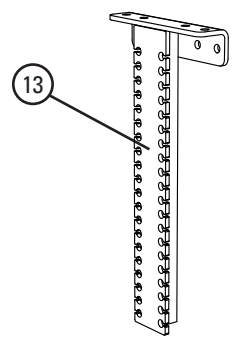
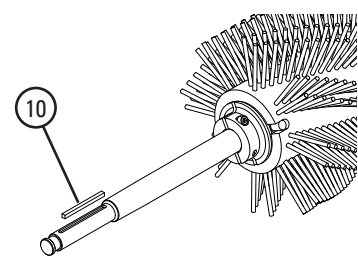
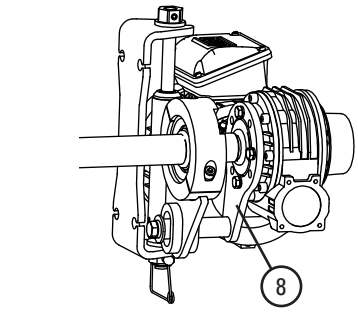

Stock items (non-shaded) refer to (\*) for specific lead time, if not specified, standard lead time applies.  
 Non-stock items (shaded) please contact Flexco for dispatch options and lead times.

# Product Ordering Information

**Chevron  
Belt Cleaner**

## Chevron Belt Cleaner

BELT WIDTH	DRUM WIDTH	ORDERING NUMBER	ITEM CODE	WT. KG
mm	mm			
450	450	CBC18	76668	34.9
600	600	CBC24	76669	40.0
750	750	CBC30	76670	45.0
900	900	CBC36	76671	50.1
1050	1050	CBC42	76672	55.1
1200	1200	CBC48	76673	60.2
1350	1350	CBC54	76674	65.2
1500	1500	CBC60	76675	70.3

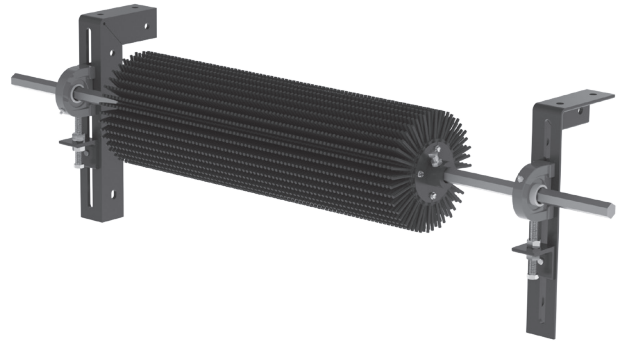

## Replacement Parts

REF	DESCRIPTION	ORDERING NUMBER	ITEM CODE	WT. KG
1	450mm Drum Shaft	CBCS18	90537	6.9
	600mm Drum Shaft	CBCS24	90538	7.7
	750mm Drum Shaft	CBCS30	90539	8.6
	900mm Drum Shaft	CBCS36	90540	9.5
	1050mm Drum Shaft	CBCS42	90541	10.3
	1200mm Drum Shaft	CBCS48	90542	11.2
	1350mm Drum Shaft	CBCS54	90543	12.0
	1500mm Drum Shaft	CBCS60	90544	12.9
2	Chevron Pillow Block*	CPB	76692	0.6
3	450mm Replacement Drum w/Fingers*	CRDF18	90631	12.6
	600mm Replacement Drum w/Fingers*	CRDF24	90632	16.8
	750mm Replacement Drum w/Fingers*	CRDF30	90633	21.0
	900mm Replacement Drum w/Fingers*	CRDF36	90634	25.2
	1050mm Replacement Drum w/Fingers*	CRDF42	90635	29.4
	1200mm Replacement Drum w/Fingers*	CRDF48	90636	33.6
	1350mm Replacement Drum w/Fingers*	CRDF54	90637	37.8
	1500mm Replacement Drum w/Fingers*	CRDF60	90638	42.0
4	75mm Replacement Finger Ring	CBC3R	90641	1.1
5	Mounting Bracket, Right	PMBR	75519	3.8
	Mounting Bracket, Left	PMBL	75516	3.8
6	Adjusting Bracket Kit* (1 ea.)	PAB	75513	0.9

\*Hardware Included

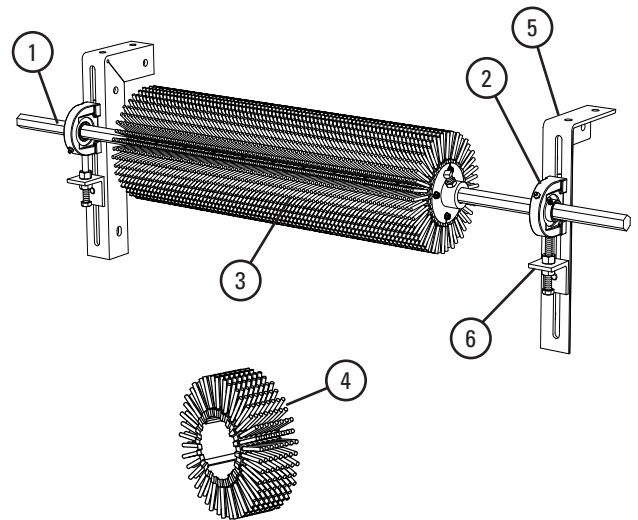

## Product Notes:

- Free-rotating. Works only when the belt is running.
- Self-cleaning. Finger length, spacing and the rotary action allows carryback to fall free instead of clogging.
- Easy to install. Few parts and step-by-step instructions make the job simple.
- Long-wearing SBR rubber. Drum life ranges from 1–3 years depending upon application conditions and material conveyed.
- Works on reversing belts.
- Finger rings can be replaced individually or all at once by replacing the drum.

## Specifications:

- Maximum Belt Speed .....2.5 m/s
- Vertical and Horizontal Clearance.....250 mm
- Temperature Rating .....-35 to 82°C
- Maximum Chevron or Cleat Height .....25 mm
- Finger Length .....50 mm
- Rubber Durometer.....45A
- Overall Diameter.....238 mm
- Shaft Length.....Belt Width plus 750 mm
- Shaft Diameter .....25 mm Hex
- CEMA Cleaner Rating .....Class 3

Stock items (non-shaded) refer to (\*) for specific lead time, if not specified, standard lead time applies.  
Non-stock items (shaded) please contact Flexco for dispatch options and lead times.

# Product Ordering Information

## Wash Box

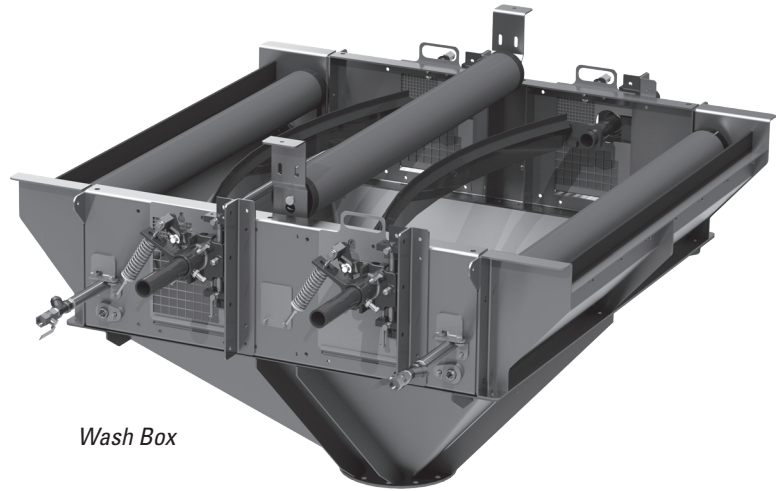

Wash Box

### Wash Box

Belt Width	"A"	"B"	"C"	"D"	MASS	VOLUME
	Outside Conveyor Stringers	Mounting Hole Centres	Overall Width	Height to Outlet Flange	Excludes Cleaners & Rollers	Enclosed in Wash Box
mm	mm	mm	mm	mm	Kg	m <sup>3</sup>
600	910	850	1,085	940	295	0.7
750	1,060	1,000	1,235	955	310	0.8
900	1,210	1,150	1,385	995	330	1.0
1,050	1,360	1,300	1,535	1,015	345	1.1
1,200	1,510	1,450	1,685	1,060	365	1.3
1,350	1,710	1,650	1,885	1,110	390	1.5
1,400	1,760	1,700	1,935	1,125	395	1.6
1,500	1,860	1,800	2,035	1,150	410	1.7
1,600	2,060	2,000	2,235	1,210	435	1.9
1,800	2,260	2,200	2,435	1,265	465	2.2
2,000	2,460	2,400	2,635	1,325	505	2.4

### Product Notes:

- Please contact Flexco for pricing and lead time.
- The dimensions, mass and volumes shown here are nominal for a standard Flexco Wash Box and will be confirmed to suit each specific application.
- Each Stainless Steel Wash Box comes equipped with a combination of pressure rollers, spray bars and recovery system.
- Wash Box is designed to accommodate any two secondary cleaners from the Flexco range, belt cleaners are sold separately.
- Non-standard sizes available, please contact Flexco.

Stock items (non-shaded) refer to (\*) for specific lead time, if not specified, standard lead time applies.

Non-stock items (shaded) please contact Flexco for dispatch options and lead times.

# Product Ordering Information

## Water Spray Pole Systems Belt Cleaner Accessories

### Stand-Alone Spraybar Assemblies 38mm dia.

BELT WIDTH	ORDERING NUMBER	ITEM CODE	WT. KG
mm			
600	SB600A	A0887	4.0
750	SB750A	A0407	5.0
900	SB900A	A0912	5.5
1050	SB1050A	A0435	6.0
1200	SB1200A	A0316	7.0
1400	SB1400A	A1620	8.0
1500	SB1500A	A1838	9.0
1800	SB1800A	A1357	10.0

Spray Assembly includes spraybar, brass plug, Y strainer, nozzles, and brackets to mount independently to structure.



### Secondary Spraybar Assemblies

BELT WIDTH	ORDERING NUMBER	ITEM CODE	WT. KG
mm			
600	SB600-SEC	61063	4.0
750	SB750-SEC	61064	5.0
900	SB900-SEC	61065	5.5
1050	SB1050-SEC	61066	6.0
1200	SB1200-SEC	61067	7.0
1400	SB1400-SEC	61068	8.0
1500	SB1500-SEC	61069	9.0
1800	SB1800-SEC	61070	10.0

Secondary Cleaner Spraybar Assemblies are designed to be clamped to secondary cleaners. Each assembly includes spraybar, nozzles, brass plug, Y strainer, and clamping brackets to mount to secondary cleaner.

Lead time: 3 weeks



### Water Control Manifold

ORDERING NUMBER	ITEM CODE	WT. KG
WCB	A0012	10.0

Water Control Manifolds come complete with the following:

- 13 mm BSP connections
- Solenoid valve (24V DC Standard)
- Pressure regulator
- Filter strainer
- Lockable ball valves
- Manual bypass line
- Stainless steel backing plate

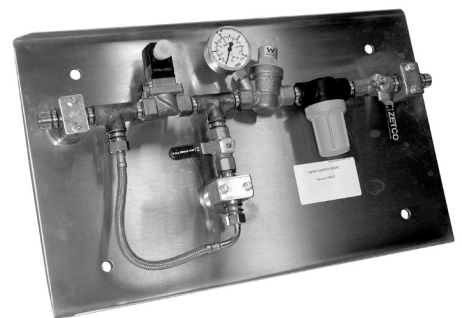

### Spray Nozzles Per Cleaner Size

mm	450	600	750	900	1050	1200	1350	1500	1800	2100	2400	3000
Spray Nozzles	1	2	2	3	3	4	4	5	6	7	8	10

 Stock items (non-shaded) refer to (\*) for specific lead time, if not specified, standard lead time applies.

 Non-stock items (shaded) please contact Flexco for dispatch options and lead times.



# Product Ordering Information

## Water Spray Pole Systems Belt Cleaner Accessories

### PS Spraywash with V-Tips

BELT WIDTH mm	ORDERING NUMBER	ITEM CODE	WT. KG
600	PS600	73014	27.0
750	PS750	73541	31.0
900	PS900	73542	33.0
1050	PS1050	73543	37.0
1200	PS1200	73544	40.0
1400	PS1400	73546	42.0
1500	PS1500	73545	47.0
1800	PS1800	73537	62.0
2000	PS2000	73539	68.0

All Stainless Steel construction. Spraywash cleaners supplied standard with nozzles, deflector shields, Brass plug, and brass Y strainer.  
Lead time: 4 weeks

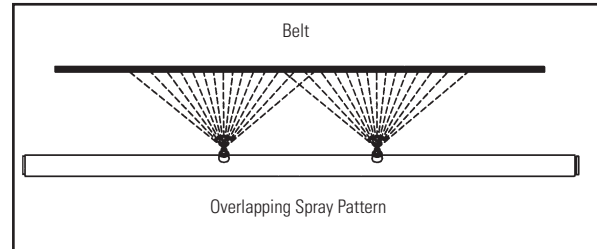
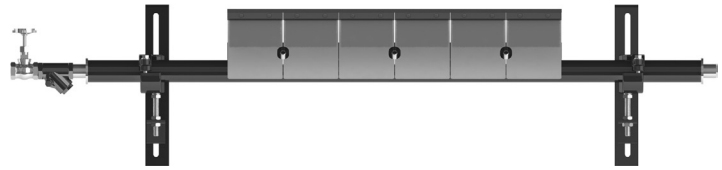

### Replacement Tips and Nozzles

BELT WIDTH mm	600	750	900	1050	1200	1400	1500	1800	2000
No. Tips/Cushions Required	4	5	6	7	8	9	10	12	13
No. Nozzles Required	2	3	3	3	4	5	5	6	7

### Replacement Parts

DESCRIPTION	POLE DIAMETER	BELT WIDTH	POLE LENGTH	ORDERING NUMBER	ITEM CODE	WT. KG
	mm	mm	mm			
PS Spray Poles	60	600	1350	PS600PL	73582	15.0
		750	1500	PS750PL	73583	16.0
		900	1650	PS900PL	73584	19.0
		1050	1800	PS1050PL	73585	22.0
		1200	1950	PS1200PL	73586	26.0
	73	1400	2200	PS1400PL	73587	29.0
		1500	2350	PS1500PL	73588	33.0
		1800	2650	PS1800PL	74049	36.0
		2000	2850	PS2000 PL	74050	40.0
P-V Tip			PVT6-S/S	75420	0.4	
PH High Speed Cushion - Stainless			PHSC-S/S	73433	1.0	
Spray Nozzle			PSN11010	74053	1.0	
Valve Assembly			PSVA	73434	1.0	
Water Control Board - 24 Volt DC			WCB	A0012	10.0	
Stainless Shield - Notch			PSSS-N	73221	0.5	
Stainless Shield - Hole			PSSS-H	73222	0.5	
Spraybar 'U' Clamp			SB-UC38-S/S	A1536	0.1	
Spraybar Mounting Bracket			SB-MB-S/S	A1535	0.7	
Compact Spray Bar Clamp			FCSBC-S/S	68867	0.8	
Malex1' BSP			Reduce Adap F 3/4	61058	0.1	
BSP Brass			HEX Plug 3/4	61057	0.1	
600mm Spraybar			SB600	A0886	2.1	
750mm Spraybar			SB750	A0408	2.3	
900mm Spraybar			SB900	A0696	2.6	
1050mm Spraybar			SB1050	A0334	2.8	
1200mm Spraybar			SB1200	A0863	3.0	
1400mm Spraybar			SB1400	A0827	3.4	
1500mm Spraybar			SB1500	A2033	3.7	
1800mm Spraybar			SB1800	A0317	4.1	
2100mm Spraybar			SB2100	61287	4.6	
2400mm Spraybar			SB2400	A1776	5.0	

### Specifications

- Stainless steel pole with stainless steel clamping brackets.
- Spray nozzles are spaced on 300 mm centers.
- Spray nozzles delivers 3.9 litres per minute, per nozzle at 300 kPa.
- Maximum inlet pressure is 1000 kPa.
- Typical pressure setting is 200-600 kPa.

# Product Ordering Information

## Live-Shaft Hold-Down Roll Belt Cleaner Accessories

### Live-Shaft Hold-Down Roll

BELT WIDTH	ROLL DIAMETER	ORDERING NUMBER	ITEM CODE	WT. KG
mm	mm			
600	114	HDR24	79010	72.3
750	114	HDR30	79011	76.8
900	114	HDR36	79012	81.8
1050	114	HDR42	79013	86.4
1200	114	HDR48	79014	113.2
1350	114	HDR54	79015	115.9
1500	114	HDR60	79016	120.5
1800	127	HDRS72*	79017	256.8
2100	127	HDRS84*	79018	279.5

\*1800 mm and 2100 mm feature solid roll

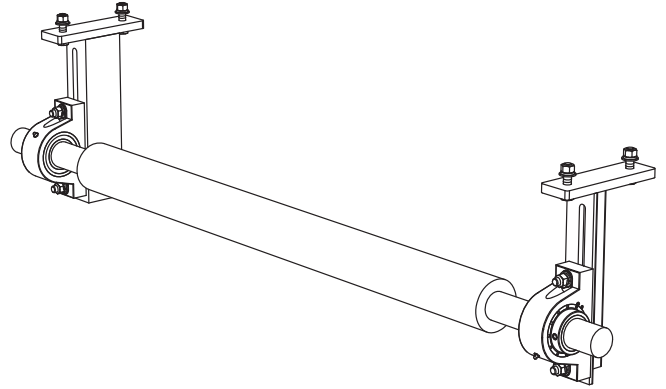

### Replacement Roll

BELT WIDTH	ROLL DIAMETER	ORDERING NUMBER	ITEM CODE	WT. KG
mm	mm			
600	114	HDRR24	79019	51.8
750	114	HDRR30	79020	56.4
900	114	HDRR36	79021	61.4
1050	114	HDRR42	79022	65.9
1200	114	HDRR48	79023	92.7
1350	114	HDRR54	79024	95.5
1500	114	HDRR60	79025	100.0
1800	127	HDRRS72*	79026	236.4
2100	127	HDRRS84*	79027	259.1

\*1800 mm and 2100 mm feature solid roll

### Roller Bracket Kit\*

DESCRIPTION	ORDERING NUMBER	ITEM CODE	WT. KG
Hold Down Roll Bracket Kit - 600–1500mm	HDRBK	79009	20.5
HD Hold Down Roll Bracket Kit - 1800–2100mm	HDRBK-HD	79072	20.5

\*Includes Left and Right Bracket

### Add-On Grease Hose Extension Kit

DESCRIPTION	ORDERING NUMBER	ITEM CODE	WT. KG
Grease Hose Extension Kit (incl. 2 ea. 400mm hose w/fittings and tie-downs)	HDRGEK	79236	0.5

### Product Notes:

- For use in applications with belt cup or belt flap.
- By preventing these issues secondary cleaner performance and blade/tip life is enhanced.

### Specifications:

- Overall Roll Length..... Belt Width +150 mm
- Overall Shaft Length..... Belt Width +750 mm
- Shaft Diameter ..... 600–1050 mm - 49.2 mm diameter  
1200–1500 mm - 61.9 mm diameter  
1800–2100 mm - 74.6 mm diameter
- Shaft Construction..... 600–1500 mm - 1045 CD  
1800–2100 mm - turned from solid 4140 round stock

Stock items (non-shaded) refer to (\*) for specific lead time, if not specified, standard lead time applies.  
Non-stock items (shaded) please contact Flexco for dispatch options and lead times.



# Product Ordering Information

## Belt Cleaner Accessories

### Stabilising Roller Bracket Kit\*

Provides universal brackets to mount the user's return roller as a hold-down (stabilising) roller on top of the return side belt. Holds the belt flat so the belt cleaner can maximize its cleaning performance.

DESCRIPTION	ORDERING NUMBER	ITEM CODE	WT. KG
Stabilising Roller Bracket Kit	SRBK	74941	15.5

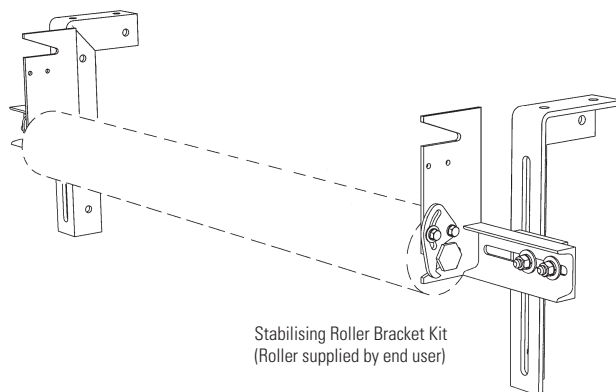

### Hold Down Roll Assembly Kits

DESCRIPTION	ORDERING NUMBER	ITEM CODE	WT. KG
Hold Down Roll Assembly Kit S/S 15mm*	HDRP15	64140	1.9
Hold Down Roll Assembly Kit S/S 17mm*	HDRP17	63679	1.9
Hold Down Roll Assembly Kit S/S 22mm*	HDRP22	63678	1.9

Kit includes:

- Stainless Steel Hold Down Roller Pole Kit to suit 17mm or 22mm A/F Roller
- S/S Mounting Kit

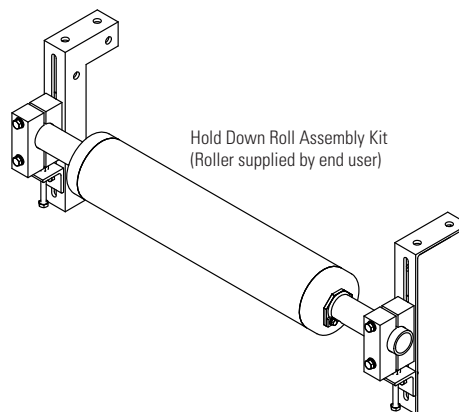

### Tip Tension Scale

For easy checking of blade tension on all H-Type® Primary Cleaners.

DESCRIPTION	ORDERING NUMBER	ITEM CODE	WT. KG
H Tip Tension Scale	HTTS	74141	0.1

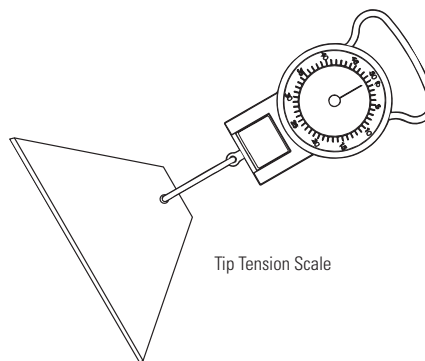

### Spring Tension Chart (recommended tensions)

CLEANER	HXF	H V-TIP	H PROTECTED V-TIP	HI-TEMP V-TIP
Kg	12.7	8.2	8.2	8.2

For installation and for retensioning blades during maintenance.

### Belt Cleaner Handy Wrench

A ratcheting wrench with 2 common socket sizes (17 mm & 19 mm) for belt cleaner installation and maintenance.

DESCRIPTION	ORDERING NUMBER	ITEM CODE	WT. KG
Belt Cleaner Handy Wrench	HW-BC	74100	0.6

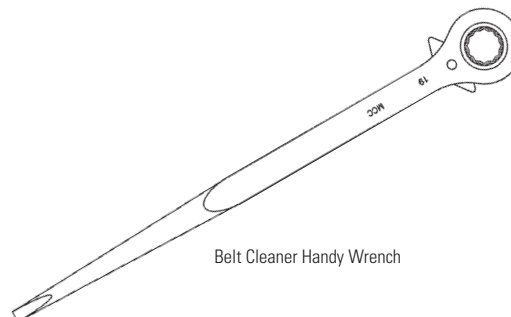

Stock items (non-shaded) refer to (\*) for specific lead time, if not specified, standard lead time applies.

Non-stock items (shaded) please contact Flexco for dispatch options and lead times.

# Product Ordering Information

## Optional Mounting Kits

### OPTIONAL MOUNTING KITS FOR BELT CLEANERS

Versatile, adjustable brackets and plates that can be mounted on the conveyor structure so Primary Cleaners and secondary cleaners can be easily and quickly bolted into place.

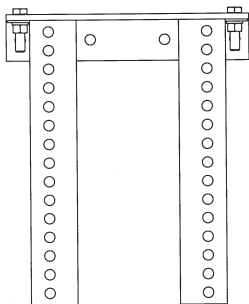

#### 76071

Standard Mounting Bracket Kit  
 • For most secondary cleaner installs.

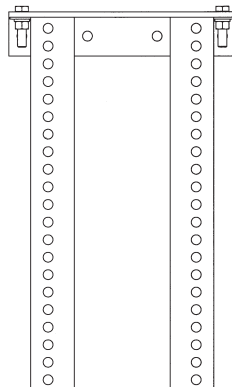

#### 76072

Long Mounting Bracket Kit  
 • For installations that require extra length legs.

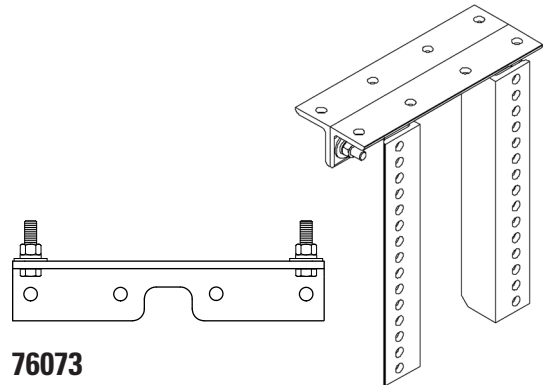

#### 76073

Optional Top Angle Kit  
 • Used with both standard and long mounting bracket kits for additional mounting options.

### Optional Mounting Kits

(includes 2 brackets/bars)

DESCRIPTION	ORDERING NUMBER	ITEM CODE	WT. KG
Standard Mounting Bracket Kit*	SSTSMB	76071	15.6
Long Mounting Bracket Kit*	SSTLMB	76072	19.7

Hardware Included

### Specifications:

- Standard brackets are 330 mm W x 394 mm L.
- Long brackets are 330 mm W x 546 mm L.
- Mounting bars are 38 mm W x 406 mm L with (4) 16-279 mm tapped holes.
- Mounting plates are 406 mm W x 813 mm L with (4) 16 mm holes.

### Pole Extender Kit

(includes 2 pole extenders)

DESCRIPTION	ORDERING NUMBER	ITEM CODE	WT. KG
Pole Extender Kit	MAPEK	76024	9.9

Provides 750 mm of extended pole length.

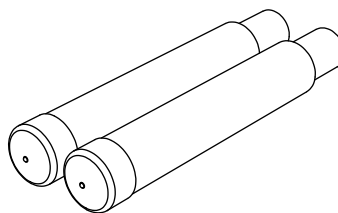

Stock items (non-shaded) refer to (\*) for specific lead time, if not specified, standard lead time applies.  
 Non-stock items (shaded) please contact Flexco for dispatch options and lead times.

## What is a Flexco Smart Belt Cleaner?

Flexco Smart Belt Cleaners harness the power of Flexco Elevate® to allow real-time, remote monitoring of belt cleaners to increase operational efficiency and transparency. The Flexco Elevate® IoT System combines the i3 Device, i3 Mobile App, and i3 Dashboard with just a few easy steps and within minutes you can transform your belt cleaners into Smart Belt Cleaners. Once the I3 device is installed on any Flexco belt cleaner pole, insights are immediately transferred to Elevate dashboard. That information combines with maintenance information that is logged via the mobile app to provide predictive data-driven insights direct to your dashboard so you can monitor belt cleaner productivity and measure internal efficiencies remotely.

## What are the Benefits of a Smart Belt Cleaner?\*

- **Asset management:** Digital mapping of all installed cleaners at your location and across your operations provides visibility of assets and allows for more efficient resource planning.
- **Increased Productivity:** Elevate® makes it easy to manage your belt cleaner service, you know exactly when and where to deploy maintenance support
- **Improved Safety:** Elevate® reduces, and in most cases eliminates, the need for dangerous physical inspection along the beltlines.
- **No Guesswork:** Your team will know exactly when and where service is needed on Flexco cleaners from the convenience of the dashboard.
- **ROI from Day One:** Data insights are immediately transferred to your Elevate Dashboard so you can realise an increase in operational efficiency from day one.
- **Leverages Existing Assets:** The Elevate® Platform works with your existing Flexco belt cleaners – no additional investment in cleaners is required.
- **Remarkably Easy:** From installation and activation, to app and dashboard, everything about Flexco Elevate® is user-friendly and designed to make your job easier.

\* Specific benefits vary between solutions

## The Power of Insights

- **Data build insights:** Data are the foundation of insights, and more data collected on your site equates to more insights.
- **Ground truth:** Ground truth collection is the process of matching real-world situations to the data collected, and all insights are created based on ground truth validation.
- **Technology partners:** Flexco teams up with world-class partners to provide various development and data science features to turn data into insights as well as storing, securing and managing data for Flexco's digital solutions.

## Evolving Tools

- **Unlike physically manufactured products, digital solutions are remotely upgraded over time to enable more features.** This continuous upgrade strategy allows users to have the most up-to-date security, insights and enhancements available (select feature enhancements will be fee-based).

# Product Ordering Information

**Flexco Elevate®**  
i3 Device, i3 Dashboard, i3 App

## Smart Cleaner Package

Upgrade any new cleaner to a Flexco Smart Cleaner by adding the item code below to your order. Smart Cleaner Packaging includes the i3 device, and platform subscription for the life of the device.

**Note:** Does not include replacement batteries.

DESCRIPTION	INCLUSIONS	ORDERING NUMBER	ITEM CODE
"Smart Cleaner" Package (Outright Purchase)	Device and lifetime subscription for new cleaners only	DVC-CLR1-AU	91602

Contact Flexco for bulk quantity pricing.



## Subscriptions:

Upgrade any new cleaner to a Flexco Smart Cleaner by adding the item code below to your order. Minimum subscription period is 2 years. Subscription fee includes the device.

DESCRIPTION	INCLUSIONS	ORDERING NUMBER	ITEM CODE
New Cleaner Subscription	Device and minimum 2 year subscription	DVC-SUB-N-AU	109370
Existing Cleaner Subscription	Device and minimum 2 year subscription	DVC-SUB-U-AU	103971

## Product Notes:

- i3 device is approved for all Flexco precleaner and secondary applications using Flexco blades or blade segments.
- Device accommodates 73mm pole; 60mm pole requires pole adapter.
- Subscription will not activate (start date) until the cleaner profile information is submitted.

## Replacement Parts

REF	DESCRIPTION	ORDERING NUMBER	ITEM CODE
1	i3 Device Back Cover Kit, Australia** (1 ea.)	DVCR-CLR-BC1AU	91603
2	i3 Device Back Cover Screw Pack (4 screws)	DVCR-CLR-BC2	91604
3	i3 Device Battery (1 ea.)	DVCR-CLR-BTR1	91605
4	i3 Device Top Cover** (1 ea. incl. screw & washer)	DVCR-CLR-TC2	91606
5	i3 Device Top Cap Screw Pack (4 screws, 4 washers)	DVCR-CLR-TC3	91607
6	i3 Device Top Cap Kit** (incl. top cap & 1 ea. items 4 & 5)	DVCR-CLR-TC1	91608
7	i3 Device 60mm Pole Adapter (1 ea.)	DVCR-CLR-ADT	91597
8a	i3 Device 73mm Pole Extender** (1 ea.)	DVCR-CLR-EX73	91595
8b	i3 Device 60mm Pole Extender** (1 ea.)	DVCR-CLR-EX60	91596

\*\*Hardware included

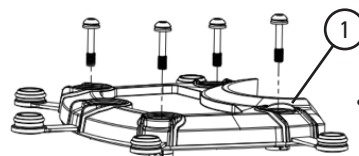

**Note:**

- Back cover kits must be ordered according to the original installation country.

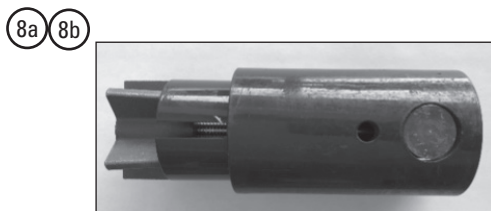
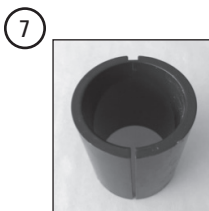
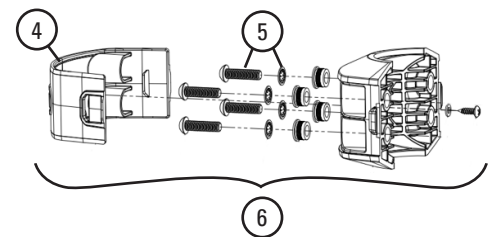
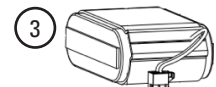
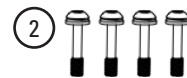

Stock items (non-shaded) refer to (\*) for specific lead time, if not specified, standard lead time applies.  
Non-stock items (shaded) please contact Flexco for dispatch options and lead times.

# Specifications & Guidelines

## Flexco Elevate® i3 Device, i3 Dashboard, i3 App

### Clearance Guidelines for Installation

POLE LENGTH OUTSIDE THE TENSIONER	CLEARANCE RADIUS AROUND POLE*
mm	mm
90	200

\*i3 device requires clearance to rotate (precleaner application) or compress (secondary cleaner application) as the blade/tip wears.

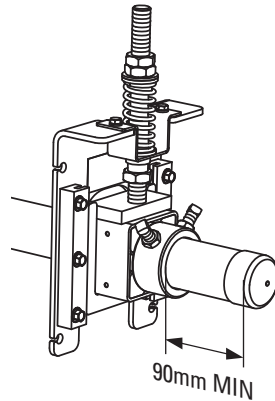

Pole length requirement outside tensioner

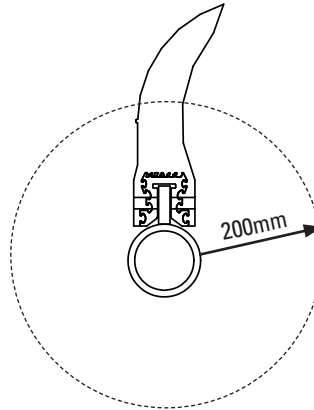

Precleaner 200mm clearance radius around pole

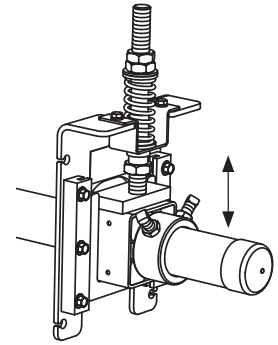

Secondary cleaner travel clearance

### Regulatory, Certifications, Standards, Explosive Environments

<b>AUSTRALIA</b>
RCM, IP66, RoHS, IECEx**

\*\*Contact Flexco regarding specific standards

### i3 Dashboard System Requirements

BROWSER	DEVICE
Any (optimized for Google Chrome)	Desktop, tablet, or smartphone (optimization for all types is continuous process)

### i3 Mobile Application Requirements

OPERATING SYSTEM	BLUETOOTH® WIRELESS COMMUNICATION	INTERNET CONNECTION (Cell Service)
Android, iOS	Required	Not required

### Specifications:

- Temperature Rating: -30°C to +65°C (-20°C to +40°C in explosive environments)
- Battery type: Non-rechargeable, lithium metal thionyl chloride (Li/SOCl<sub>2</sub>)
- i3 Dashboard and i3 Mobile App languages: English, Spanish, German, French
- i3 Dashboard and i3 Mobile App units: Imperial/Metric

U.S. Patent #: 10,836,585

# Product Ordering Information

## *Universal Lightweight Pole* For use with H-Type, FMS, MHS and P-Type Cleaners

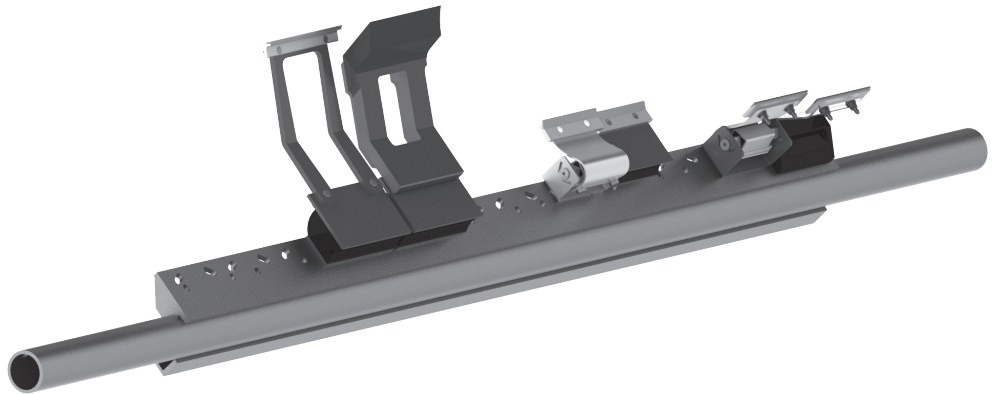

### Universal Lightweight Pole

BELT WIDTH	ORDERING NUMBER	ITEM CODE	WT. KG
mm			
450	ULP450	66122	5.8
600	ULP600	66123	6.6
750	ULP750	66124	7.5
900	ULP900	66125	8.5
1050	ULP1050	66126	12.2
1200	ULP1200	66127	13.6
1350	ULP1350	66128	15.3
1500	ULP1500	66129	16.6
1650	ULP1650	66130	18.0
1800	ULP1800	67057	19.4
2000	ULP2000	67084	21.6
2200	ULP2200	67085	22.9
2400	ULP2400	67058	24.6
2600	ULP2600	67086	26.6
2800	ULP2800	67087	28.4
3000	ULP3000	67088	30.1

\*Lead time 3 weeks.

Note: The Universal Lightweight Pole is not supplied with a tensioner.

### Product Notes:

- Safety Driven Engineering. The lightest cleaner pole on the market, engineered with safe lifting in mind.
- Versatile. Compatible with Flexco H-Type®, FMS, MHS & P-Type® Cleaners.
- Made for Australian Mining Conditions. Although lightweight, the universal pole has been tested to withstand the harshest mining conditions in Australia.

Stock items (non-shaded) refer to (\*) for specific lead time, if not specified, standard lead time applies.  
Non-stock items (shaded) please contact Flexco for dispatch options and lead times.

# Product Ordering Information

## H-Type®, P-Type®, R-Type® Lightweight Pole



H-Type Lightweight Pole



P-Type Lightweight Pole

### H-Type®, P-Type® & R-Type® Lightweight Poles

DESCRIPTION	ORDERING NUMBER	ITEM CODE	WT. KG
<b>H-Type</b>			
HPA1200 LIGHTWEIGHT POLE	HPA1200	69469	12.5
HPA1350 LIGHTWEIGHT POLE	HPA1350	69470	13.4
HPA1500 LIGHTWEIGHT POLE	HPA1500	69471	14.7
HPA1600 LIGHTWEIGHT POLE	HPA1600	69472	16.1
HPA1800 LIGHTWEIGHT POLE	HPA1800	69473	17.4
HPA2000 LIGHTWEIGHT POLE	HPA2000	69474	19.0
HPA2200 LIGHTWEIGHT POLE	HPA2200	69475	20.5
HPA2400 LIGHTWEIGHT POLE	HPA2400	69476	22.0
HPA2600 LIGHTWEIGHT POLE	HPA2600	69477	23.8
HPA2800 LIGHTWEIGHT POLE	HPA2800	69478	25.3
HPA3000 LIGHTWEIGHT POLE	HPA3000	69479	26.8
<b>P-Type</b>			
PPA1200 LIGHTWEIGHT POLE	PPA1200	69480	12.5
PPA1350 LIGHTWEIGHT POLE	PPA1350	69481	14.0
PPA1500 LIGHTWEIGHT POLE	PPA1500	69482	15.1
PPA1650 LIGHTWEIGHT POLE	PPA1650	69483	16.3
PPA1800 LIGHTWEIGHT POLE	PPA1800	69484	17.4
PPA1950 LIGHTWEIGHT POLE	PPA1950	69485	18.8
PPA2100 LIGHTWEIGHT POLE	PPA2100	69486	20.1
PPA2250 LIGHTWEIGHT POLE	PPA2250	69487	21.4
PPA2400 LIGHTWEIGHT POLE	PPA2400	69488	22.0
<b>R-Type</b>			
RPA1200 LIGHTWEIGHT POLE	RPA1200	103602	12.5
RPA1350 LIGHTWEIGHT POLE	RPA1350	103603	14.1
RPA1500 LIGHTWEIGHT POLE	RPA1500	103604	15.3
RPA1800 LIGHTWEIGHT POLE	RPA1800	103605	17.6
RPA1950 LIGHTWEIGHT POLE	RPA1950	103606	19.0
RPA2100 LIGHTWEIGHT POLE	RPA2100	103607	20.6
RPA2400 LIGHTWEIGHT POLE	RPA2400	103608	22.3

\*Lead time 3 weeks.

Stock items (non-shaded) refer to (\*) for specific lead time, if not specified, standard lead time applies.

Non-stock items (shaded) please contact Flexco for dispatch options and lead times.



# Product Ordering Information

## Inspection Doors

Flexco can create inspection doors and cleaner mount inspection doors to suit your system. Please contact customer service for more details.

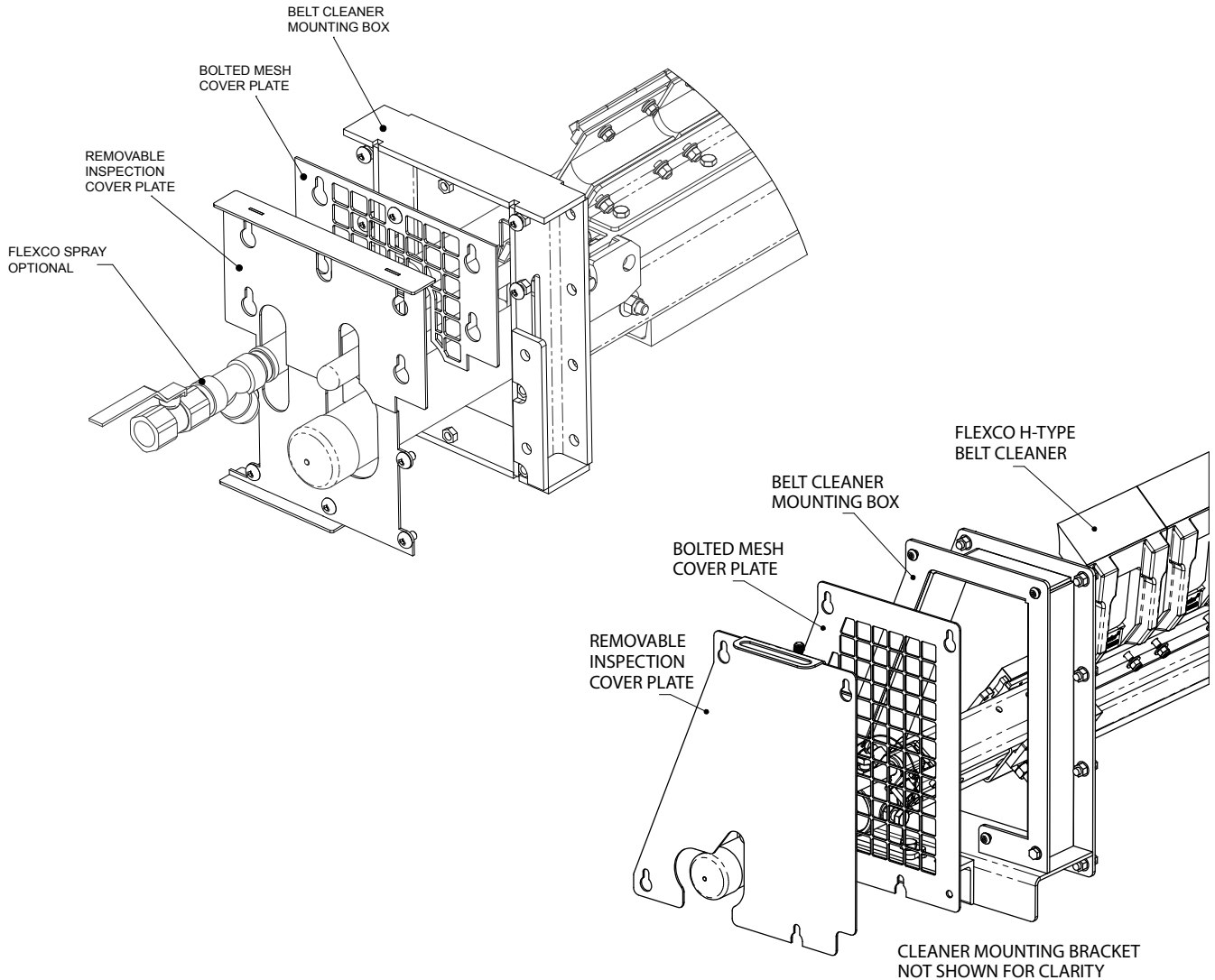

### Product Notes:

- Please contact Flexco for pricing and lead times.
- Inspection doors are available in a range of sizes, please contact your Flexco representative or customer service for more information.
- Inspection doors can also be designed to your specifications.
- Constructed from heavy-duty grade 316 Stainless Steel.
- The solid outer door can be safely opened by hand without the need for any tools during normal operation of the equipment.
- The inner door features 3mm mesh at 50mm spacing and requires tools to remove ensuring workers remain safe behind the mesh.
- Cleaner tensions sit outside the mesh, allowing for staff to safely and effectively tension cleaners.

**Stock items** (non-shaded) refer to (\*) for specific lead time, if not specified, standard lead time applies.
   
 **Non-stock items** (shaded) please contact Flexco for dispatch options and lead times.

# Product Ordering Information

## Inspection Doors

### Inspection Boxes

Description	ITEM CODE
Small H-Type Cleaner Box Kit	67586
Large H-Type Cleaner Box Kit	67587

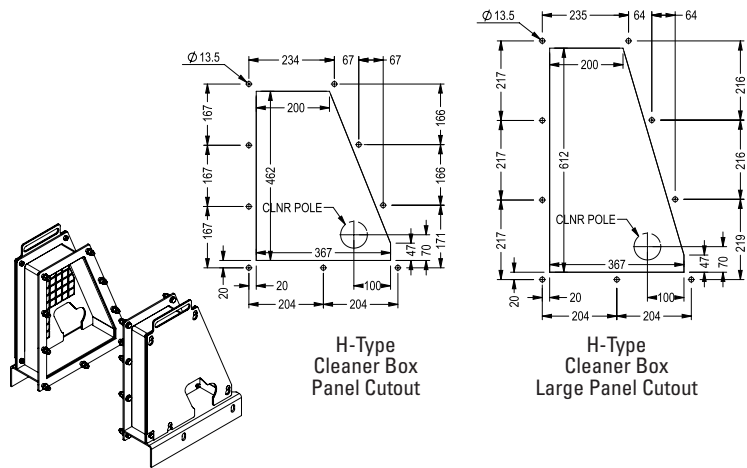

H-Type Cleaner Box Panel Cutout

H-Type Cleaner Box Large Panel Cutout

### Inspection Boxes

Description	ITEM CODE
Inspection Box - Dual Secondary MST	68844
Inspection Box - Dual Secondary MST Kit*	67268
Inspection Box - Single Secondary MST	67267
Inspection Box - Single Secondary MST Kit*	67437

Kit includes 2 inspection boxes

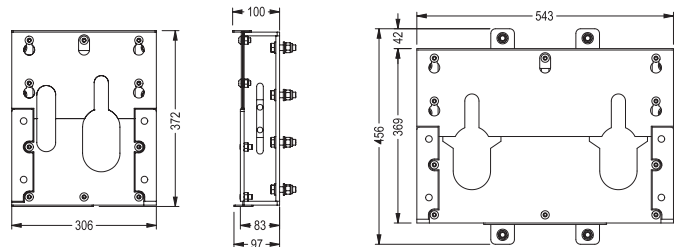

Single

Dual

### Inspection Doors

Description	ITEM CODE
ID300x300 S/S Inspection Door	62445
ID400x400 S/S Inspection Door	62446
ID500x500 S/S Inspection Door	62447
ID600x600 S/S Inspection Door	62448

All doors are weld-on installation; for bolt-on, please contact Flexco.

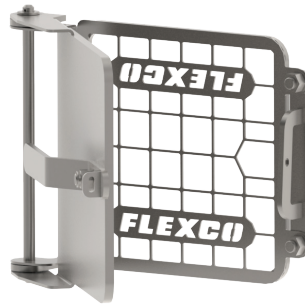

**Please note:** All Access Doors are made from grade 316 stainless steel. The outer door is solid c/w with lockable handle and the inner door is 3 mm mesh at 50 mm spacing.

Stock items (non-shaded) refer to (\*) for specific lead time, if not specified, standard lead time applies.  
 Non-stock items (shaded) please contact Flexco for dispatch options and lead times.

## SAMPLE SPECIFICATIONS AND GUIDELINES

### Inspection Door 300 mm x 300 mm

Chute Opening:	300mm x 300mm
Outer Door:	Solid c/w Lockable Handle
Inner Mesh Door:	3mm mesh @ 50mm spacing
Material:	Grade 316 Stainless Steel
Overall Weight:	8kg

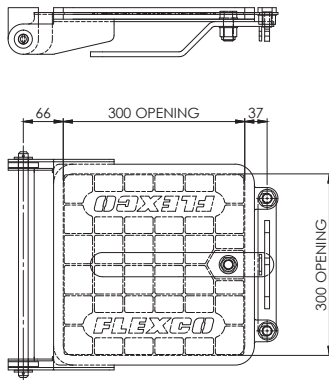

### Inspection Door 400 mm x 400 mm

Chute Opening:	400mm x 400mm
Outer Door:	Solid c/w Lockable Handle
Inner Mesh Door:	3mm mesh @ 50mm spacing
Material:	Grade 316 Stainless Steel
Overall Weight:	13kg

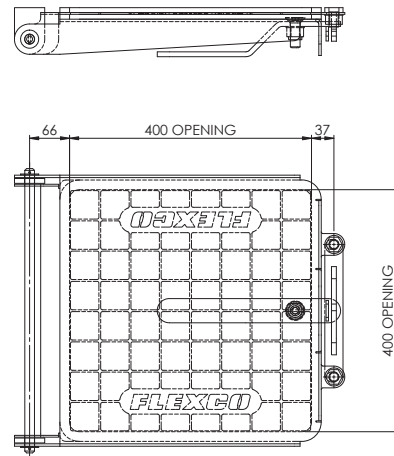

### Inspection Door 500 mm x 500 mm

Chute Opening:	500mm x 500mm
Outer Door:	Solid c/w Lockable Handle
Inner Mesh Door:	3mm mesh @ 50mm spacing
Material:	Grade 316 Stainless Steel
Overall Weight:	18kg

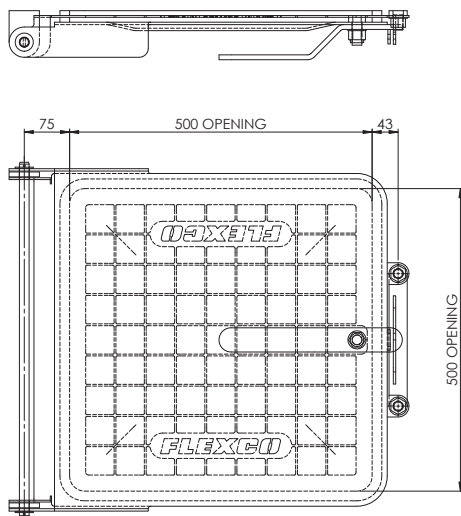

### Inspection Door 600 mm x 600 mm

Chute Opening:	600mm x 600mm
Outer Door:	Solid c/w Lockable Handle
Inner Mesh Door:	3mm mesh @ 50mm spacing
Material:	Grade 316 Stainless Steel
Overall Weight:	32kg

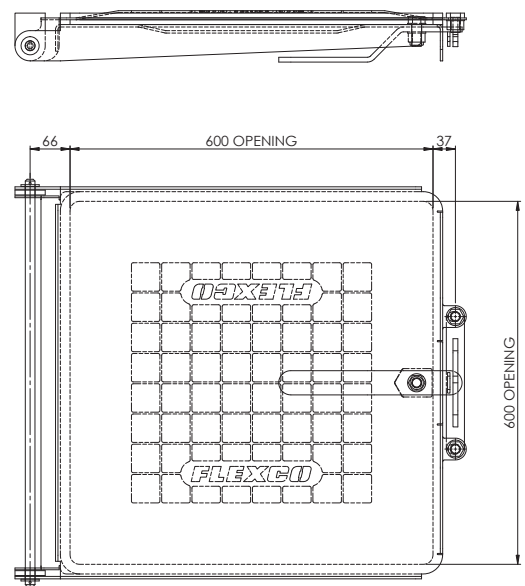

# Product Ordering Information

## Mandrel Safety Removal Systems Belt Cleaner Accessories

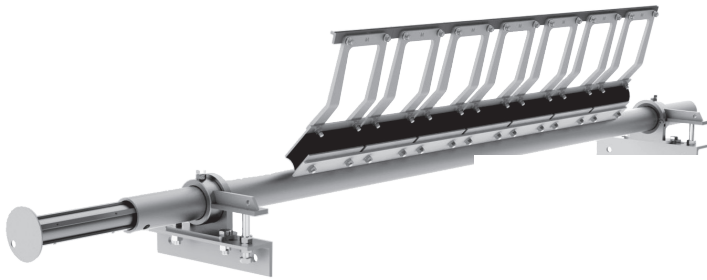

H-Type® primary cleaner shown (cleaner not included)

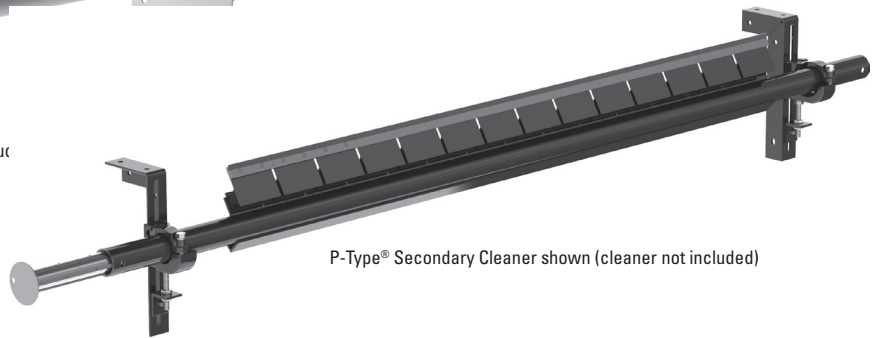

P-Type® Secondary Cleaner shown (cleaner not included)

### Galvanised Mandrel Poles

BELT WIDTH	CLEANER POLE DIA.	ORDERING NUMBER	ITEM CODE	WT. KG
mm	mm			
450	60	MR-450PG	A2836	5.0
600	60	MR-600PG	A2837	6.0
750	60	MR-750PG	A2838	6.5
900	60	MR-900PG	A2839	7.5
1050	60	MR-1050PG	A2840	8.5
1200	60	MR-1200PG	A2841	9.0
1500	73	MR-1500PG	A2829	10.0
1600	73	MR-1600PG	A2830	11.0
1800	73	MR-1800PG	A2831	12.0
2100	73	MR-2100PG	A2832	13.5
2400	73	MR-2400PG	A2833	15.0
2600	73	MR-2600PG	A2834	16.5
3000	73	MR-3000PG	A2835	19.0

A Mandrel Kit requires 1 pole, 1 left hand block and 1 right hand block.

Lead time: 3 weeks

### Cradle H Bearings-Primary Cleaners

POWDER COATED				
ORDERING NUMBER	ITEM CODE	POLE DIA.	WT. KG	
		mm		
PMR-CHB-L73	61075	73	1.5	
PMR-CHB-R73	61076	73	1.5	
PMR-CHB-L60	61073	60	1.3	
PMR-CHB-R60	61074	60	1.3	

### Cradle Clamp Blocks-Secondary Cleaners

POWDER COATED				
ORDERING NUMBER	ITEM CODE	POLE DIA.	WT. KG	
		mm		
SMR-CCB-L73	A2842	73	4.0	
SMR-CCB-R73	A2843	73	4.0	
SMR-CCB-L60	A2844	60	3.2	
SMR-CCB-R60	A2845	60	3.2	

Stock items (non-shaded) refer to (\*) for specific lead time, if not specified, standard lead time applies.  
Non-stock items (shaded) please contact Flexco for dispatch options and lead times.

# Product Ordering Information

## Standard Pulley Lifters

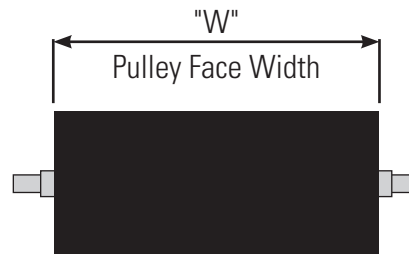
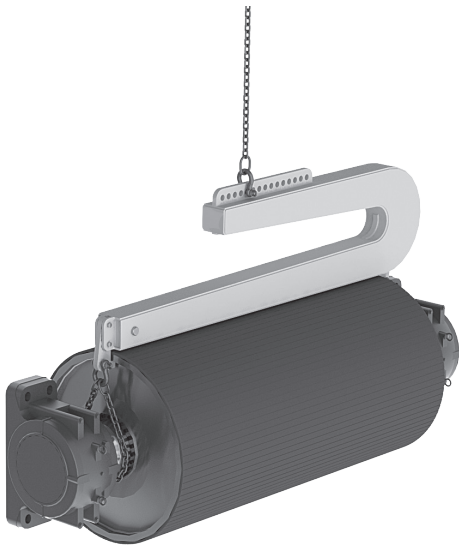

### Pulley Face Widths

	800-1200	1200-1600	1600-2000	2000-2400
3 TONNE CAPACITY	1-PL-800-1200-3	1-PL-1200-1600-3	1-PL-1600-2000-3	1-PL-2000-2400-3
6 TONNE CAPACITY	1-PL-800-1200-6	1-PL-1200-1600-6	1-PL-1600-2000-6	1-PL-2000-2400-6
12 TONNE CAPACITY	1-PL-800-1200-12	1-PL-1200-1600-12	1-PL-1600-2000-12	1-PL-2000-2400-12

### Product Notes:

- Please contact Flexco for pricing and lead times.
- Made from high strength steel to Australian Standards.
- Each pulley lifter proof load tested after manufacture and supplied with certificate of compliance and a safety operations and maintenance manual.
- Supplied in safety yellow as standard (other colours available on request).

**Stock items** (non-shaded) refer to (\*) for specific lead time, if not specified, standard lead time applies.

**Non-stock items** (shaded) please contact Flexco for dispatch options and lead times.

# Product Ordering Information

## Flexco Belt Maintenance Tools Belt Lifters & Clamps

### Flex-Lifter™ Conveyor Belt Lifter

Easy and safe way to lift tensioned belts so mechanical splicing or other maintenance work can be done.

REF	DESCRIPTION	ORDERING NUMBER	ITEM CODE	WT. KG
-	Medium Flex-Lifter 900-1500mm	FLM	76979	27.3
-	Large Flex-Lifter 1200-1800mm	FLL	76980	33.6
-	XL Flex-Lifter 1800-2400mm	FLXL	76983	68.5
REPLACEMENT PARTS				
1a	Extension Leg - Medium	FLEL-M	76472	1.4
1b	Extension Leg - Large	FLEL-L	76473	1.7
1c	Extension Leg - XL (incl. 2 ext. legs)	FLELK-XL	76986	5.9
2	Extension Leg Pin (w/ lanyard)	FLELP	76474	0.1
3a	Trough Wing - Medium (w/ brace)	FLTW-M	76476	0.6
3b	Trough Wing - Large (w/ brace)	FLTW-L	76477	0.7
3c	Trough Wing - XL (w/ brace)	FLTW-XL	76985	2.0
4	Retainer Pin Pack (incl. 4 pins)	FLRP	76478	0.5
5	Retainer Clip Pack (incl. 4 clips)	FLCP	76479	0.1
6a	M-L Shear Pin Kit	FL-PKIT-ML	77250	0.1
6b	XL Shear Pin Kit	FL-PKIT-XL	77251	0.2
7a	Return Lift Bar - Medium	FLRLB-M	76482	8.4
7b	Return Lift Bar - Large	FLRLB-L	76481	18.2
7c	V-Return Lift Bar - XL	FLVRL-XL	76984	28.6
-	Flex-Trolley	FLCK	77729	N/A

Return lift bars included with medium and large models.  
Sold separately with XL models.

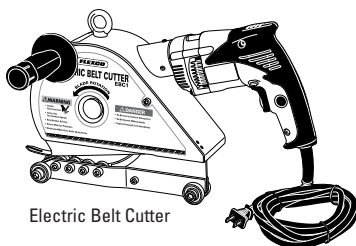
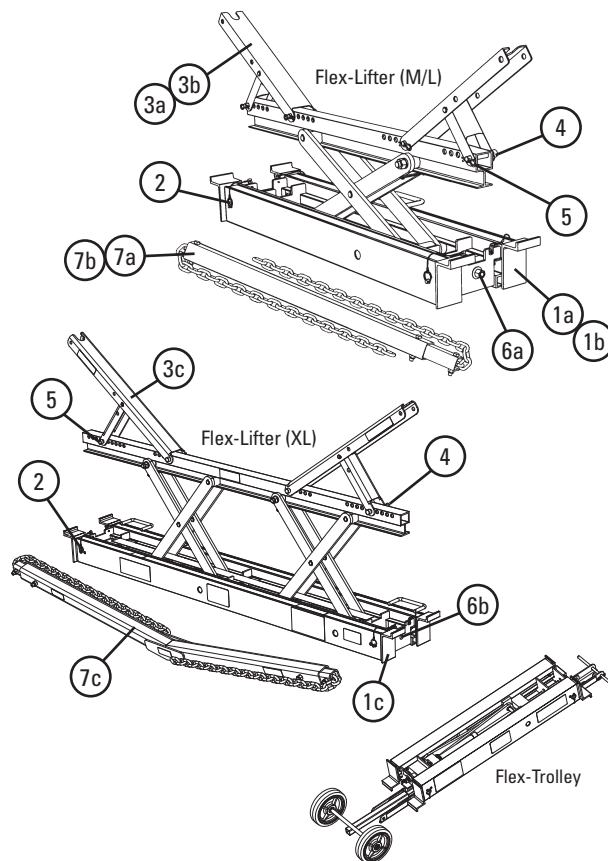

Electric Belt Cutter

### Cutting Capacity

BELT TYPE	EBC-1	EBC-2
Rubber	Up to 25 mm	Up to 50 mm
PVC	Up to 630 EP	Up to 2000 EP

### Aluminum Content - Flex-Lifter

ALUMINUM ALLOY TYPE	PERCENT	
	MG- MAGNESIUM	TI- TITANIUM
4043	0.05%	0.2%
5356	5.5%	0.2%
6005	0.6%	0.1%
6061	1.0%	0.0%
6063	0.7%	0.0%
7075	2.5%	0.0%

### Belt Cutter with Case

DESCRIPTION	ORDERING NUMBER	ITEM CODE	WT. KG
ELECTRIC			
Electric Cutter Complete - 25mm	EBC-1	30001	9.0
Electric Cutter Complete - 50 mm	EBC-2	30002	10.0
Cordless Electric Cutter Complete - 25mm	CEBC-1	30018	9.0
Cordless Electric Cutter Complete - 50mm	CEBC-2	30019	10.0
PNEUMATIC			
Pneumatic Cutter Complete - 25mm	PBC-1	61356	12.5
Pneumatic Cutter Complete - 50mm	PBC-2	61357	13.5
REPLACEMENT PARTS			
Filter Set (PBC Only)	PBC-FR	61358	2.0
EBC1 Case	EBC1 Case	30009	8.0
EBC2 Case	EBC2 Case	30010	8.0
CEBC1 Case	CEBC1 Case	30020	8.0
CEBC2 Case	CEBC2 Case	30023	8.0
PBC1 Case	PBC1 Case	U8393	8.0
PBC2 Case	PBC2 Case	U8394	8.0

A filter/regulator must be used with all Pneumatic Belt Cutters.

### Belt Cutter without Case

DESCRIPTION	ORDERING NUMBER	ITEM CODE	WT. KG
ELECTRIC			
Electric Cutter Complete - 25mm	EBC-1-NC	108846	10.0
Electric Cutter Complete - 50mm	EBC-2-NC	108847	10.5
Cordless Electric Cutter Complete - 25mm	CEBC-1-NC	108848	9.0
Cordless Electric Cutter Complete - 50mm	CEBC-2-NC	108849	9.5
PNEUMATIC			
Pneumatic Cutter Complete - 25mm	PBC-1-NC	108850	10.0
Pneumatic Cutter Complete - 50mm	PBC-2-NC	108851	10.5
REPLACEMENT PARTS			
Replacement blade for EBC-1	EBC-1-B	30003	1.0
Replacement blade for EBC-2	EBC-2-B	30004	1.0
Retrofit Rail Kit for EBC1/CEBC1/PBC1	EBC1-RK	30033	0.6
Retrofit Rail Kit for EBC2/CEBC2/PBC2	EBC2-RK	30034	0.8

Stock items (non-shaded) refer to (\*) for specific lead time, if not specified, standard lead time applies.

Non-stock items (shaded) please contact Flexco for dispatch options and lead times.

# Specifications & Guidelines

## Flexco Slider/Impact Beds

### Easy Solution for Load Zone Problems

- Complete load zone offering with slider beds through impact beds for up to 100 kg-m of force.
- No specifying trough angle; each bed is adjustable for 20°, 35° and 45° trough settings (ships at 35° setting)
- Low-profile installation. Because Flexco beds feature trough wings that are adjustable, they lay flat during installation, providing more clearance.
- Full UHMW slider bars included on outside bar to provide proper sealing and long life.
- Unique Impact Bar Supports protect the impact bars from damage, extending service life. An Anti-Migratory Tab on each support secures the bar and prevents it from sliding in the direction of belt travel.
- All beds are manufactured for mounting holes belt width + 250 mm (600–1200 mm beds), + 300 mm (1350–1500 mm beds), and + 400 mm (1800 mm beds). For wider structure, contact Customer Service for special quote.

**How to spec the correct slider/impact bed for your conveyor transfer point**

**Roller Size**  
 127mm  152mm  178mm   
**Belt Width:** \_\_\_\_\_  
**Bed Length:** 1200mm  1500mm

### Impact Energy Calculation Chart

**Impact Energy**

Lump Weight (**w**) \_\_\_\_\_  
 Drop Height (**h**) **x** \_\_\_\_\_  

---

 Total = **kg-m**    See Below

0 kg-m — **EZSB-C**  
 0 - 25kg-m — **EZSB-I or EZIB-L**  
 25-100 kg-m — **EZIB-M**



# Product Ordering Information

## EZSB-C Flexco Slider Beds Steel Rolls

Contact Flexco for information and pricing on shorter lead times and non-standard impact beds. Please note that freight for all impact beds are ex-works

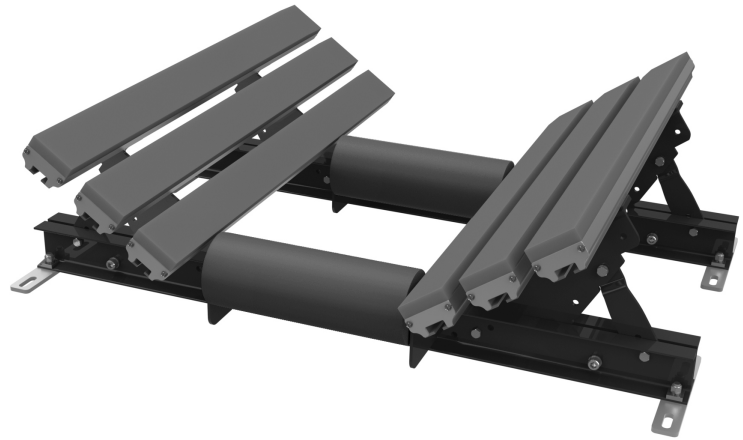

### Flexco Slider Bed with Steel Rolls 1200 mm (for non-impact areas)

BELT WIDTH	ORDERING NUMBER	ITEM CODE	WT. KG
mm			
600	EZSB600-1200C	82185	110.7
750	EZSB750-1200C	82186	119.4
900	EZSB900-1200C	82187	131.1
1050	EZSB1050-1200C	82188	162.7
1200	EZSB1200-1200C	82189	175.0
1350	EZSB1350-1200C	82190	206.4
1500	EZSB1500-1200C	82191	217.1
1800	EZSB1800-1200C	82192	232.7

Lead time: 4 weeks

### Flexco Slider Bed with Steel Rolls 1500 mm (for non-impact areas)

BELT WIDTH	ORDERING NUMBER	ITEM CODE	WT. KG
mm			
600	EZSB600-1500C	82193	118.4
750	EZSB750-1500C	82194	126.9
900	EZSB900-1500C	82195	138.6
1050	EZSB1050-1500C	82196	173.7
1200	EZSB1200-1500C	82197	186.2
1350	EZSB1350-1500C	82198	221.4
1500	EZSB1500-1500C	82199	232.1
1800	EZSB1800-1500C	82200	247.6

Lead time: 4 weeks

### Product Notes:

- No need to specify troughing angle—designed to adjust to 20°, 35°, 45°.
- Designed for containment in the load zone, but not intended for impact zones.
- Slider bars are solid 25mm UHMW providing longer wear life and consistent load zone sealing.
- Product ships with two idlers. Additional idlers can be added by purchasing a EZRMK and the appropriate corresponding idler.

# Replacement Parts List

## EZSB-C Flexco Slider Beds Steel Rolls

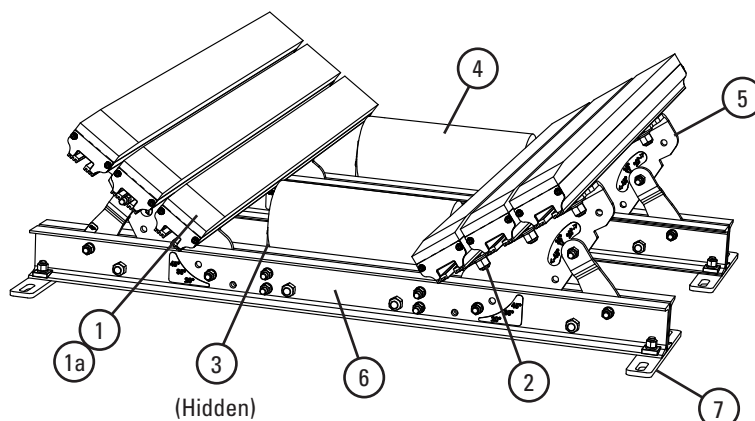

### Replacement Parts

REF	DESCRIPTION	ORDERING NUMBER	ITEM CODE	WT. KG
1	Slider Bar, 1200mm	SB4	78789	9.1
1a	Slider Bar, 1500mm	SB5	78790	10.9
2	Bar Bolt Kit (incl. 1 ea. 16mm carriage bolt, square washer, flat washer, lock washer, Nylock nut)	RIBBK	81250	0.2
3	Slider Roll Mount Kit*	EZRMKM	82344	2.3
4	Roll 600mm*	N6D3T-24-9-A45	83715	4.1
	Roll 750mm*	N6D3T-30-11-A45	83716	4.8
	Roll 900mm*	N6D3T-36-13-A45	83717	5.6
	Roll 1050mm*	N6D3T-42-15-A45	83718	6.3
	Roll 1200mm*	N6D3T-48-17-A45	83719	7.3
	Roll 1350mm*	N6D3T-54-19-A45	83720	7.7
	Roll 1500mm*	N6D3T-60-21-A45	83721	8.2
	Roll 1800mm*	N6D3T-72-25-A45	83722	9.8
5	Wing Plate Kit 600mm*	EZWPK-600	82345	7.7
	Wing Plate Kit 750mm*	EZWPK-750	82346	7.9
	Wing Plate Kit 900mm*	EZWPK-900	82347	9.6
	Wing Plate Kit 1050mm*	EZWPK-1050	82348	11.9
	Wing Plate Kit 1200mm*	EZWPK-1200	82349	13.7
	Wing Plate Kit 1350mm*	EZWPK-1350	82350	16.1
	Wing Plate Kit 1500mm*	EZWPK-1500	82351	17.7
	Wing Plate Kit 1800mm*	EZWPK-1800	82352	21.2
6	Cross Stringer Kit 600mm*	EZCSK-600	82353	22.3
	Cross Stringer Kit 750mm*	EZCSK-750	82354	25.6
	Cross Stringer Kit 900mm*	EZCSK-900	82355	28.9
	Cross Stringer Kit 1050mm*	EZCSK-1050	82356	32.1
	Cross Stringer Kit 1200mm*	EZCSK-1200	82357	35.6
	Cross Stringer Kit 1350mm*	EZCSK-1350	82358	38.9
	Cross Stringer Kit 1500mm*	EZCSK-1500	82359	42.2
	Cross Stringer Kit 1800mm*	EZCSK-1800	82360	45.0
7	Shim Kit Light Duty (incl. 4 shims)	SHIM-LDKIT	82393	6.2

\*Hardware Included. Lead time: 4 weeks.

### Replacement Quantities for EZSB-C

mm		600	750	900	1050	1200	1350	1500	1800
NO. ROLLS REQUIRED		2	2	2	2	2	2	2	2
NO. BARS REQUIRED	SLIDER	4	4	4	6	6	8	8	8
NO. BAR BOLT KITS REQUIRED		8	8	8	12	12	16	16	16

# Product Ordering Information

## EZSB-I Flexco Slider Beds

Contact Flexco for information and pricing on shorter lead times and non-standard impact beds. Please note that freight for all impact beds are ex-works



### Flexco Slider Bed with Impact Rolls 1200 mm

(for impact zones with less than 25 Kg-m energy)

BELT WIDTH	ORDERING NUMBER	ITEM CODE	WT. KG
mm			
600	EZSB600-1200I	82201	125.6
750	EZSB750-1200I	82202	136.1
900	EZSB900-1200I	82203	149.7
1050	EZSB1050-1200I	82204	184.7
1200	EZSB1200-1200I	82205	198.2
1350	EZSB1350-1200I	82206	233.1
1500	EZSB1500-1200I	82207	246.3
1800	EZSB1800-1200I	82208	265.8

Lead time: 4 weeks

### Flexco Slider Bed with Impact Rolls 1500 mm

(for impact zones with less than 25 Kg-m energy)

BELT WIDTH	ORDERING NUMBER	ITEM CODE	WT. KG
mm			
600	EZSB600-1500I	82209	133.4
750	EZSB750-1500I	82210	143.8
900	EZSB900-1500I	82211	157.5
1050	EZSB1050-1500I	82212	196.4
1200	EZSB1200-1500I	82213	210.0
1350	EZSB1350-1500I	82214	248.9
1500	EZSB1500-1500I	82215	262.1
1800	EZSB1800-1500I	82216	281.3

Lead time: 4 weeks

### Product Notes:

- No need to specify troughing angle—designed to adjust to 20°, 35°, 45°.
- Outermost trough bar features 25mm solid UHMW slider bar to provide longer wear life and consistent load zone sealing where impact is not present.

Stock items (non-shaded) refer to (\*) for specific lead time, if not specified, standard lead time applies.
   
 Non-stock items (shaded) please contact Flexco for dispatch options and lead times.

# Replacement Parts List

## EZSB-I Flexco Slider Beds

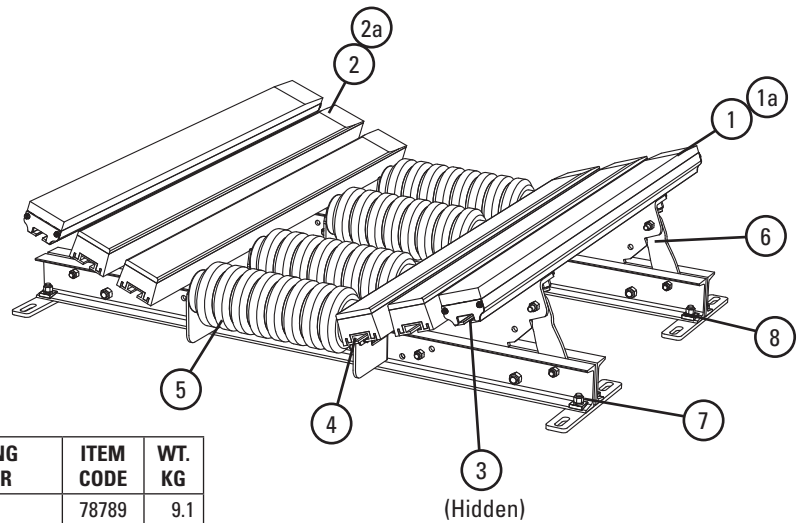

### Replacement Parts

REF	DESCRIPTION	ORDERING NUMBER	ITEM CODE	WT. KG
1	Slider Bar, 1200mm	SB4	78789	9.1
1a	Slider Bar, 1500mm	SB5	78790	10.9
2	Impact Bar, 1200mm	IB4	76926	7.7
2a	Impact Bar, 1500mm	IB5	76927	9.5
3	Bar Bolt Kit (incl. 1 ea. 16mm carriage bolt, square washer, flat washer, lock washer, Nylock nut)	RIBBK	81250	0.2
4	Slider Roll Mount Kit*	EZRMKM	82344	2.3
5	Impact Roll 600mm*	NI6D3T-24-9-A45	26184	4.6
	Impact Roll 750mm*	NI6D3T-30-11-A45	26185	5.4
	Impact Roll 900mm*	NI6D3T-36-13-A45	26186	6.3
	Impact Roll 1050mm*	NI6D3T-42-15-A45	26187	7.3
	Impact Roll 1200mm*	NI6D3T-48-17-A45	26188	8.1
	Impact Roll 1350mm*	NI6D3T-54-19-A45	26189	9.0
	Impact Roll 1500mm*	NI6D3T-60-21-A45	26190	9.8
	Impact Roll 1800mm*	NI6D3T-72-25-A45	26191	11.6
6	Wing Plate Kit 600mm*	EZWPK-600	82345	7.7
	Wing Plate Kit 750mm*	EZWPK-750	82346	7.9
	Wing Plate Kit 900mm*	EZWPK-900	82347	9.6
	Wing Plate Kit 1050mm*	EZWPK-1050	82348	11.9
	Wing Plate Kit 1200mm*	EZWPK-1200	82349	13.7
	Wing Plate Kit 1350mm*	EZWPK-1350	82350	16.1
	Wing Plate Kit 1500mm*	EZWPK-1500	82351	17.7
	Wing Plate Kit 1800mm*	EZWPK-1800	82352	21.2
7	Cross Stringer Kit 600mm*	EZCSK-600	82353	22.3
	Cross Stringer Kit 750mm*	EZCSK-750	82354	25.6
	Cross Stringer Kit 900mm*	EZCSK-900	82355	28.9
	Cross Stringer Kit 1050mm*	EZCSK-1050	82356	32.1
	Cross Stringer Kit 1200mm*	EZCSK-1200	82357	35.6
	Cross Stringer Kit 1350mm*	EZCSK-1350	82358	38.9
	Cross Stringer Kit 1500mm*	EZCSK-1500	82359	42.2
	Cross Stringer Kit 1800mm*	EZCSK-1800	82360	45.0
8	Shim Kit Light Duty (incl. 4 shims)	SHIM-LDKIT	82393	6.2

\*Hardware Included. Lead time: 4 weeks.

### Replacement Quantities for EZSB-I

mm		600	750	900	1050	1200	1350	1500	1800
<b>NO. ROLLS REQUIRED</b>		4	4	4	4	4	4	4	4
<b>NO. BARS REQUIRED</b>	<b>SLIDER</b>	2	2	2	2	2	2	2	2
	<b>IMPACT</b>	2	2	2	4	4	6	6	6
<b>NO. BAR BOLT KITS REQUIRED</b>		8	8	8	12	12	16	16	16

# Product Ordering Information

## **EZIB-L** **Flexco Impact Beds** *All Bars - Light Duty*

Contact Flexco for information and pricing on shorter lead times and non-standard impact beds. Please note that freight for all impact beds are ex-works



### Flexco Impact Bed Light Duty 1200 mm

(for impact zones with less than 25 Kg-m energy)

BELT WIDTH	ORDERING NUMBER	ITEM CODE	WT. KG
mm			
600	EZIB600-1200L-LP	68171	150.7
750	EZIB750-1200L-LP	68172	157.1
900	EZIB900-1200L-LP	68173	184.8
1050	EZIB1050-1200L-LP	68174	234.9
1200	EZIB1200-1200L-LP	68175	263.4
1350	EZIB1350-1200L-LP	68176	311.6
1500	EZIB1500-1200L-LP	68177	344.6
1800	EZIB1800-1200L-LP	68178	387.8

Lead time: 4 weeks

### Flexco Impact Bed Light Duty 1500 mm

(for impact zones with less than 25 Kg-m energy)

BELT WIDTH	ORDERING NUMBER	ITEM CODE	WT. KG
mm			
600	EZIB600-1500L-LP	68179	171.2
750	EZIB750-1500L-LP	68180	177.6
900	EZIB900-1500L-LP	68181	209.4
1050	EZIB1050-1500L-LP	68182	267.7
1200	EZIB1200-1500L-LP	68183	300.2
1350	EZIB1350-1500L-LP	68184	356.6
1500	EZIB1500-1500L-LP	68185	393.8
1800	EZIB1800-1500L-LP	68186	441.0

Lead time: 4 weeks

### Product Notes:

- No need to specify troughing angle—designed to adjust to 20°, 35°, 45°.
- Outermost trough bar features 25mm solid UHMW slider bar to provide longer wear life and consistent load zone sealing where impact is not present.

# Replacement Parts List

## EZIB-L Flexco Impact Beds All Bars - Light Duty

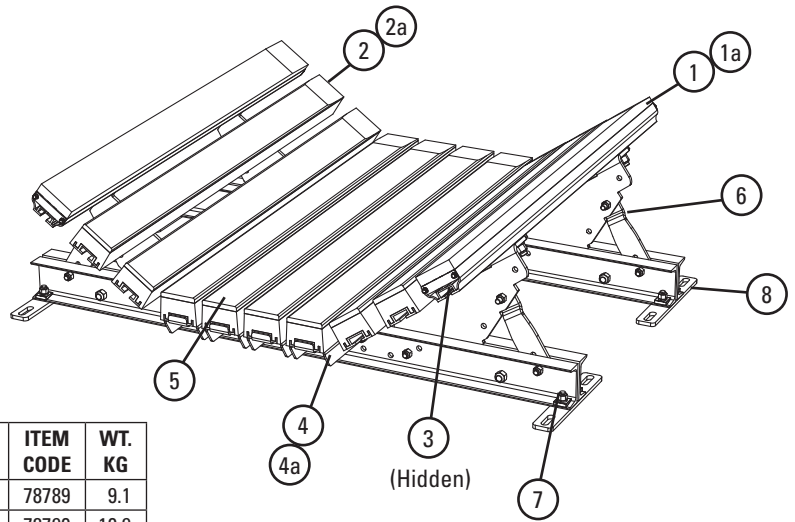

### Replacement Parts

REF	DESCRIPTION	ORDERING NUMBER	ITEM CODE	WT. KG
1	Slider Bar, 1200mm	SB4	78789	9.1
1a	Slider Bar, 1500mm	SB5	78790	10.9
2	Impact Bar, 1200mm	IB4	76926	7.7
2a	Impact Bar, 1500mm	IB5	76927	11.4
3	Bar Bolt Kit (incl. 1 ea. 16mm carriage bolt, square washer, flat washer, lock washer, Nylock nut)	RIBBK	81250	0.2
4	Impact Bar Support - 1.2M	EZBS-1200	82361	7.3
4a	Impact Bar Support - 1.5M	EZBS-1500	82362	9.3
5	Centre Bar Mount Kit 600mm*	EZBMK-600	82281	2.4
	Centre Bar Mount Kit 750mm*	EZBMK-750	82282	2.6
	Centre Bar Mount Kit 900mm*	EZBMK-900	82283	3.4
	Centre Bar Mount Kit 1050mm*	EZBMK-1050	82284	3.6
	Centre Bar Mount Kit 1200mm*	EZBMK-1200	82285	4.4
	Centre Bar Mount Kit 1350mm*	EZBMK-1350	82286	4.8
	Centre Bar Mount Kit 1500mm*	EZBMK-1500	82287	5.6
6	Centre Bar Mount Kit 1800mm*	EZBMK-1800	82288	6.6
	Wing Plate Kit 600mm*	EZWPK-600	82345	7.7
	Wing Plate Kit 750mm*	EZWPK-750	82346	7.9
	Wing Plate Kit 900mm*	EZWPK-900	82347	9.6
	Wing Plate Kit 1050mm*	EZWPK-1050	82348	11.9
	Wing Plate Kit 1200mm*	EZWPK-1200	82349	13.7
	Wing Plate Kit 1350mm*	EZWPK-1350	82350	16.1
7	Wing Plate Kit 1500mm*	EZWPK-1500	82351	17.7
	Wing Plate Kit 1800mm*	EZWPK-1800	82352	21.2
	Cross Stringer Kit 600mm*	EZRKL-600	68368	22.3
	Cross Stringer Kit 750mm*	EZRKL-750	68369	25.6
	Cross Stringer Kit 900mm*	EZRKL-900	68370	28.9
	Cross Stringer Kit 1050mm*	EZRKL-1050	68371	32.1
	Cross Stringer Kit 1200mm*	EZRKL-1200	68372	35.6
8	Cross Stringer Kit 1350mm*	EZRKL-1350	68373	38.9
	Cross Stringer Kit 1500mm*	EZRKL-1500	68374	42.2
	Cross Stringer Kit 1800mm*	EZRKL-1800	68375	45.0
8	Shim Kit Light Duty (incl. 4 shims)*	SHIM-LDKIT	82393	6.2

\*Hardware Included. Lead time: 4 weeks.

### Replacement Quantities for EZIB-L

mm		600	750	900	1050	1200	1350	1500	1800
NO. BARS REQUIRED	SLIDER	2	2	2	2	2	2	2	2
	IMPACT	4	4	5	7	8	10	11	12
NO. BAR BOLT KITS REQUIRED		14	14	17	21	24	28	31	34
NO. BAR SUPPORTS REQUIRED		2	2	3	3	4	4	5	6

# Specifications & Guidelines

## EZIB-L Flexco® Impact Beds All Bars - Light Duty

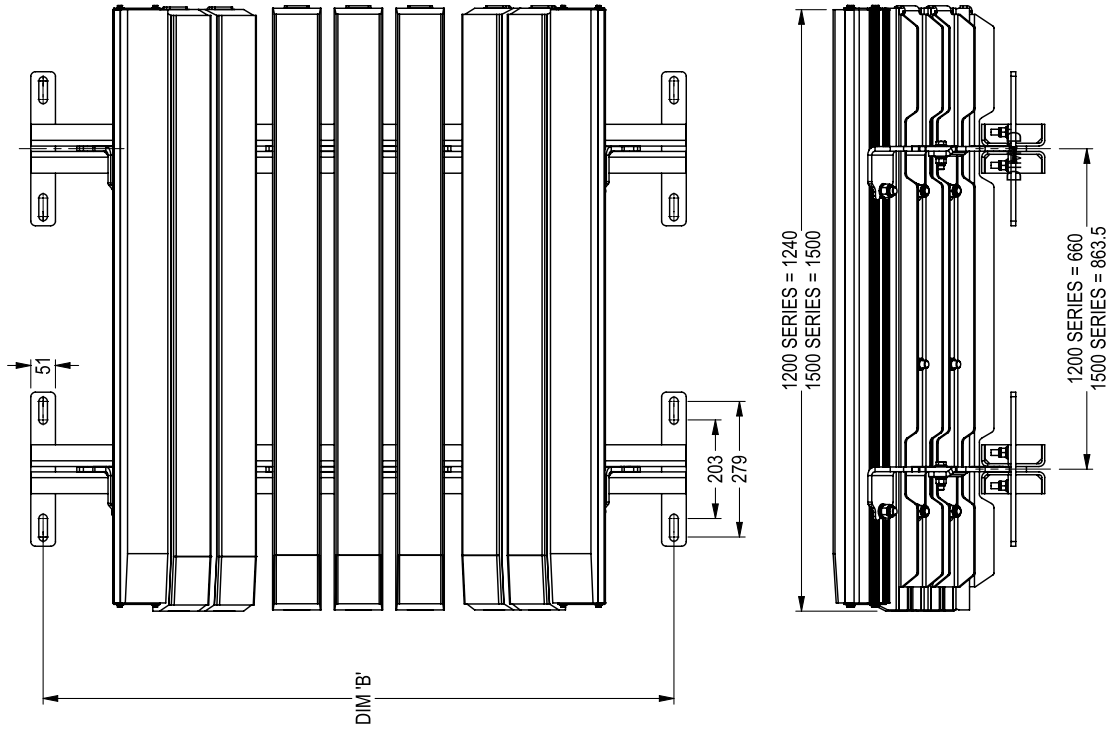

Bed Length mm	Item Code	Bed Width mm	Dim A mm	Dim B mm	Dim C mm	
1200	68171	600	780	850	900	
	68172	750	930	1000	1050	
	68173	900	1060	1150	1200	
	68174	1050	1210	1300	1350	
	68175	1200	1360	1450	1500	
	68176	1350	1560	1650	1700	
	67177	1500	1710	1800	1850	
	68187	1800	2110	2200	2250	
	68179	600	780	850	900	
	68180	750	930	1000	1050	
1500	68181	900	1060	1150	1200	
	68182	1050	1210	1300	1350	
	68183	1200	1360	1450	1500	
	68184	1350	1560	1650	1700	
	68185	1500	1710	1800	1850	
	68186	1800	2110	2200	2250	
	<b>Light Duty</b>					

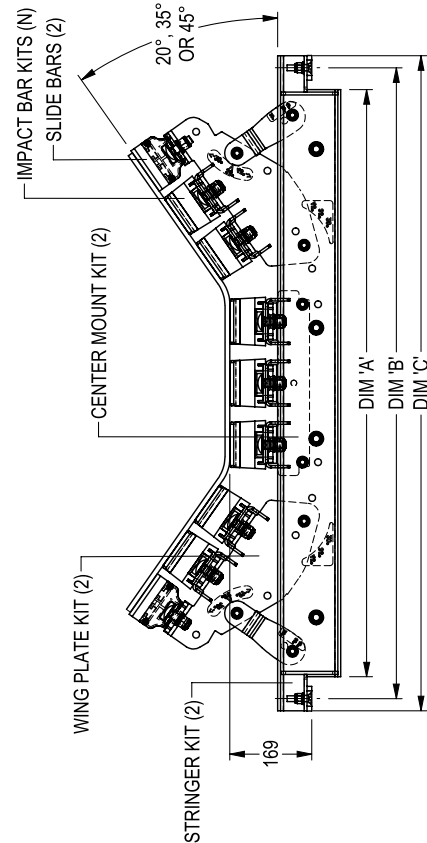



# Product Ordering Information

## **EZIB-M** *Flexco Impact Beds* *All Bars - Medium Duty*

Contact Flexco for information and pricing on shorter lead times and non-standard impact beds. Please note that freight for all impact beds are ex-works



### Flexco Impact Bed Medium Duty 1200 mm

(for impact zones with 25-100 Kg-m energy)

BELT WIDTH	ORDERING NUMBER	ITEM CODE	WT. KG
mm			
600	EZIB600-1200M-LP	68187	180.8
750	EZIB750-1200M-LP	68188	190.5
900	EZIB900-1200M-LP	68189	223.2
1050	EZIB1050-1200M-LP	68190	280.8
1200	EZIB1200-1200M-LP	68191	314.8
1350	EZIB1350-1200M-LP	68192	369.6
1500	EZIB1500-1200M-LP	68193	410.4
1800	EZIB1800-1200M-LP	68194	466.4

Lead time: 4 weeks

### Flexco Impact Bed Medium Duty 1500 mm

(for impact zones with 25-100 Kg-m energy)

BELT WIDTH	ORDERING NUMBER	ITEM CODE	WT. KG
mm			
600	EZIB600-1500M-LP	68195	201.4
750	EZIB750-1500M-LP	68196	211.0
900	EZIB900-1500M-LP	68197	247.8
1050	EZIB1050-1500M-LP	68198	313.6
1200	EZIB1200-1500M-LP	68199	351.7
1350	EZIB1350-1500M-LP	68200	414.7
1500	EZIB1500-1500M-LP	68201	459.5
1800	EZIB1800-1500M-LP	68202	519.6

Lead time: 4 weeks

### Product Notes:

- No need to specify troughing angle—designed to adjust to 20°, 35°, 45°.
- Outermost trough bar features 25 mm solid UHMW slider bar to provide longer wear life and consistent load zone sealing where impact is not present.

# Replacement Parts List

## EZIB-M Flexco Impact Beds All Bars - Medium Duty

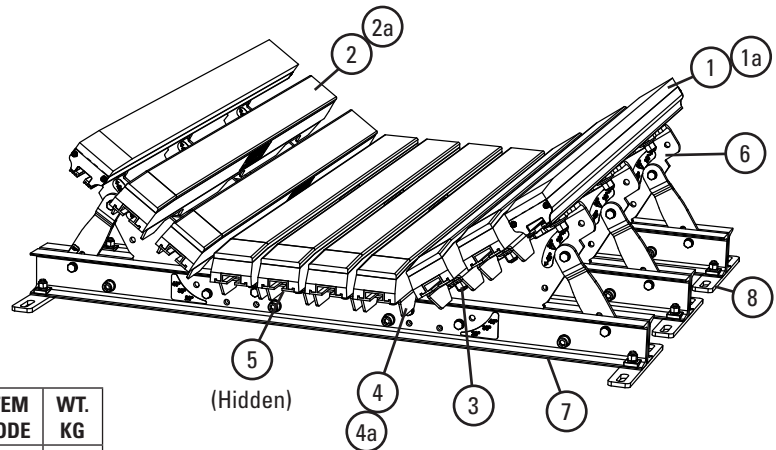

### Replacement Parts

REF	DESCRIPTION	ORDERING NUMBER	ITEM CODE	WT. KG
1	Slider Bar, 1200mm	SB4	78789	9.1
1a	Slider Bar, 1500mm	SB5	78790	10.9
2	Impact Bar, 1200mm	IB4	76926	7.7
2a	Impact Bar, 1500mm	IB5	76927	11.4
3	Bar Bolt Kit (incl. 1 ea. 16mm carriage bolt, square washer, flat washer, lock washer, Nylock nut)	RIBBK	81250	0.2
4	Impact Bar Support - 1200mm	IBS-M1200	82397	7.7
4a	Impact Bar Support - 1500mm	IBS-M1500	82398	9.6
5	Centre Bar Mount Kit 600mm*	EZBMK-600	82281	2.4
	Centre Bar Mount Kit 750mm*	EZBMK-750	82282	2.6
	Centre Bar Mount Kit 900mm*	EZBMK-900	82283	3.4
	Centre Bar Mount Kit 1050mm*	EZBMK-1050	82284	3.6
	Centre Bar Mount Kit 1200mm*	EZBMK-1200	82285	4.4
	Centre Bar Mount Kit 1350mm*	EZBMK-1350	82286	4.8
	Centre Bar Mount Kit 1500mm*	EZBMK-1500	82287	5.6
	Centre Bar Mount Kit 1800mm*	EZBMK-1800	82288	6.6
6	Wing Plate Kit 600mm*	EZWPK-600	82345	7.7
	Wing Plate Kit 750mm*	EZWPK-750	82346	7.9
	Wing Plate Kit 900mm*	EZWPK-900	82347	9.6
	Wing Plate Kit 1050mm*	EZWPK-1050	82348	11.9
	Wing Plate Kit 1200mm*	EZWPK-1200	82349	13.7
	Wing Plate Kit 1350mm*	EZWPK-1350	82350	16.1
	Wing Plate Kit 1500mm*	EZWPK-1500	82351	17.7
	Wing Plate Kit 1800mm*	EZWPK-1800	82352	21.2
7	Cross Stringer Kit 600mm*	EZRKL-600	68368	22.3
	Cross Stringer Kit 750mm*	EZRKL-750	68369	25.6
	Cross Stringer Kit 900mm*	EZRKL-900	68370	28.9
	Cross Stringer Kit 1050mm*	EZRKL-1050	68371	32.1
	Cross Stringer Kit 1200mm*	EZRKL-1200	68372	35.6
	Cross Stringer Kit 1350mm*	EZRKL-1350	68373	38.9
	Cross Stringer Kit 1500mm*	EZRKL-1500	68374	42.2
	Cross Stringer Kit 1800mm*	EZRKL-1800	68375	45.0
8	Shim Kit Medium Duty (incl. 4 shims)*	SHIM-MDKIT	82394	9.3

\*Hardware Included. Lead time: 4 weeks.

### Replacement Quantities for EZIB-M

mm		600	750	900	1050	1200	1350	1500	1800
NO. BARS REQUIRED	SLIDER	2	2	2	2	2	2	2	2
	IMPACT	4	4	5	7	8	10	11	12
NO. BAR BOLT KITS REQUIRED		26	26	31	37	42	48	53	58
NO. BAR SUPPORTS REQUIRED		4	4	5	5	6	6	7	8

# Specifications & Guidelines

## EZIB-M Flexco Impact Beds All Bars - Medium Duty

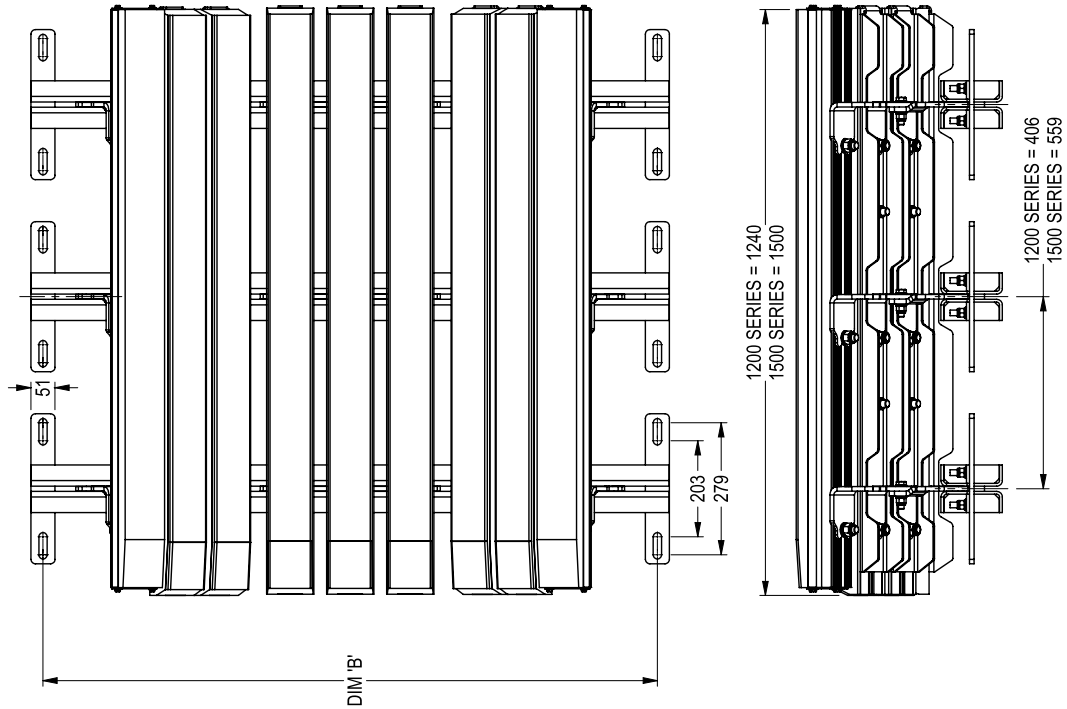

Medium Duty	Bed Length mm	Item Code	Bed Width mm	Dim A mm	Dim B mm	Dim C mm
		68188	750	930	1000	1050
		68189	900	1060	1150	1200
		68190	1050	1210	1300	1350
		68191	1200	1360	1450	1500
		68192	1350	1560	1650	1700
		68193	1500	1710	1800	1850
		68194	1800	2110	2200	2250
		68195	600	780	850	900
		68196	750	930	1000	1050
		68197	900	1060	1150	1200
		68198	1050	1210	1300	1350
		68199	1200	1360	1450	1500
		68200	1350	1560	1650	1700
		68201	1500	1710	1800	1850
		68202	1800	2110	2200	2250

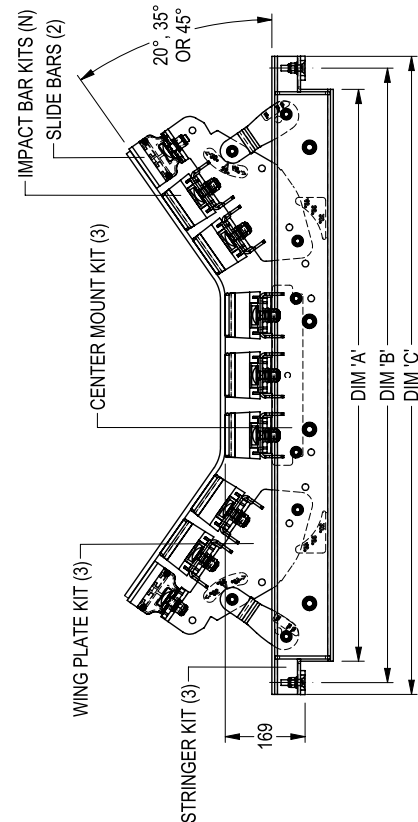

## It's the Structure, not the bars

*It absorbs more impact to save your belt. Our exclusive Velocity Reduction Technology™ provides two levels of impact relief.*

Level 1: **Impact Bars** first absorb impact energy. Unique Impact Bar Supports on all DRX™ Impact Beds allow the impact bars to function properly - expanding and absorbing more impact energy.

Level 2: On DRX™200, 750 and 1500 impact beds, **Isolation Mounts** provide a second level of reaction force reduction, absorbing additional impact energy and minimising transmission back to the belt. The DRX™3000 Dynamic has **Impact Energy Absorbers** to disperse an immense amount of impact, even in extremely severe applications.

### User-Friendly Slide-Out Service™

- All DRX Impact Beds separate in the middle to slide apart and out.
- Can be easily and safely converted from the run position to the service position.
- Impact bars are easy to get to for changeout. A complete changeout can be done in one or two hours.

**Unique Impact Bar Supports protect the impact bars from damage, extending service life. An Anti-Migratory Tab on each support secures the bar and prevents it from sliding in the direction of the belt.**

### Other Features and Benefits

- Uses exclusive anti-spin square washers. Allows use of carriage bolts to secure impact bars instead of expensive T bolts.
- Centre bars are tilted 3° inward to help centre the load on the belt.

### How to spec the correct impact bed for your conveyor transfer point

Impact Energy Calculation Chart

Largest Material Lump Weight (w)

Drop Height (h)

**ROLLER SIZE**

127 mm  152 mm

Belt Width \_\_\_\_\_

Troughing Angle: 20°  35°

Bed Length: 1.2 M  1.5 M

**IMPACT ENERGY**

Lump Weight (w) \_\_\_\_\_

Drop Height (h) x \_\_\_\_\_

---

Total=kg/Mtr \_\_\_\_\_ See Below

Up to 25 kg-m—DRX™200

25 to 100 kg-m—DRX™750

100 to 200 kg-m—DRX™1500

200 to 400 kg-m—DRX™3000

# Product Ordering Information

**DRX™200**  
Impact Beds

## DRX™200 - 1.2 M Beds, 20° Trough

BELT WIDTH	ORDERING NUMBER	ITEM CODE	WT. KG
mm			
600	DRXL-24-420	76816	118.2
750	DRXL-30-420	76817	128.2
900	DRXL-36-420	76818	146.8
1050	DRXL-42-420	76819	187.3
1200	DRXL-48-420	76820	196.8
1350	DRXL-54-420	76821	226.4
1500	DRXL-60-420	76822	246.8
1800	DRXL-72-420	76823	279.6

## DRX™200 - 1.2 M Beds, 35° Trough

BELT WIDTH	ORDERING NUMBER	ITEM CODE	WT. KG
mm			
600	DRXL-24-435	76832	118.2
750	DRXL-30-435	76833	128.2
900	DRXL-36-435	76834	146.8
1050	DRXL-42-435	76835	187.3
1200	DRXL-48-435	76836	196.8
1350	DRXL-54-435	76837	226.4
1500	DRXL-60-435	76838	246.8
1800	DRXL-72-435	76839	279.6

## DRX™200 - 1.5 M Beds, 20° Trough

BELT WIDTH	ORDERING NUMBER	ITEM CODE	WT. KG
mm			
600	DRXL-24-520	76824	131.8
750	DRXL-30-520	76825	141.4
900	DRXL-36-520	76826	162.3
1050	DRXL-42-520	76827	208.6
1200	DRXL-48-520	76828	218.2
1350	DRXL-54-520	76829	251.8
1500	DRXL-60-520	76830	273.6
1800	DRXL-72-520	76831	308.6

## DRX™200 - 1.5 M Beds, 35° Trough

BELT WIDTH	ORDERING NUMBER	ITEM CODE	WT. KG
mm			
600	DRXL-24-535	76840	131.8
750	DRXL-30-535	76841	141.4
900	DRXL-36-535	76842	162.3
1050	DRXL-42-535	76843	208.6
1200	DRXL-48-535	76844	218.2
1350	DRXL-54-535	76845	251.8
1500	DRXL-60-535	76846	273.6
1800	DRXL-72-535	76847	308.6

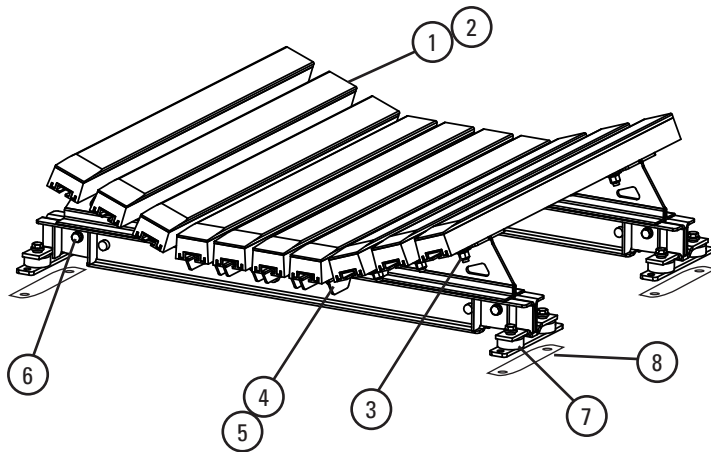



## Replacement Bars and Bolt Kits Required per Belt Width-DRX™200

BELT WIDTH								
	600	750	900	1050	1200	1350	1500	1800
mm								
No. Impact Bar Supports Required	2	2	3	4	4	4	5	6
No. Impact Bars Required	6	6	7	10	10	12	13	14
No. Impact Bar Bolt Kits Required	14	14	17	24	24	28	31	34

## Replacement Parts

REF	DESCRIPTION	ORDERING NUMBER	ITEM CODE	WT. KG
1	Impact Bar, 1.2M	IB4	76926	7.7
2	Impact Bar, 1.5M	IB5	76927	9.6
3	Impact Bar Bolt Kit incl. (1) ea. 16mm carriage bolt, square washer, flat washer, lock washer, Nylock nut	IBBK	76928	0.2
4	Impact Bar Support - L 1.2M incl. (1) ea. bar support, carriage bolt, square washer, lock washer, Nylock nut	IBS-L4	76929	7.6
5	Impact Bar Support - L 1.5M incl. (1) ea. bar support, carriage bolt, square washer, lock washer, Nylock nut	IBS-L5	76930	9.6
6	Sliding Support Arm Bolt Kit incl. (2) 50mm bolts, (2) lock washers, (2) Nylock nuts	ISABK-LMH	77529	0.9
7	Isolation Mount Kit	IMK	76936	1.7
8	DRX™200 Shim Kit (incl. 4 shims)	SHIM-KITL	77548	6.1

 Stock items (non-shaded) refer to (\*) for specific lead time, if not specified, standard lead time applies.  
 Non-stock items (shaded) please contact Flexco for dispatch options and lead times.

# Product Ordering Information

**DRX™750**  
Impact Beds

## DRX™750 - 1.2 M Beds, 20° Trough

BELT WIDTH	ORDERING NUMBER	ITEM CODE	WT. KG
mm			
600	DRXM-24-420	88363	165.9
750	DRXM-30-420	88367	180.5
900	DRXM-36-420	88371	212.3
1050	DRXM-42-420	88375	269.1
1200	DRXM-48-420	88379	283.2
1350	DRXM-54-420	88383	320.0
1500	DRXM-60-420	88387	354.1
1800	DRXM-72-420	88391	407.3

## DRX™750 - 1.2 M Beds, 35° Trough

BELT WIDTH	ORDERING NUMBER	ITEM CODE	WT. KG
mm			
600	DRXM-24-435	88365	165.9
750	DRXM-30-435	88369	180.5
900	DRXM-36-435	88373	212.3
1050	DRXM-42-435	88377	269.1
1200	DRXM-48-435	88381	283.2
1350	DRXM-54-435	88385	320.0
1500	DRXM-60-435	88389	354.1
1800	DRXM-72-435	88393	407.3

## DRX™750 - 1.5 M Beds, 20° Trough

BELT WIDTH	ORDERING NUMBER	ITEM CODE	WT. KG
mm			
600	DRXM-24-520	88364	183.2
750	DRXM-30-520	88368	197.7
900	DRXM-36-520	88372	233.6
1050	DRXM-42-520	88376	298.2
1200	DRXM-48-520	88380	312.3
1350	DRXM-54-520	88384	353.2
1500	DRXM-60-520	88388	391.4
1800	DRXM-72-520	88392	447.7

## DRX™750 - 1.5 M Beds, 35° Trough

BELT WIDTH	ORDERING NUMBER	ITEM CODE	WT. KG
mm			
600	DRXM-24-535	88366	183.2
750	DRXM-30-535	88370	197.7
900	DRXM-36-535	88374	233.6
1050	DRXM-42-535	88378	298.2
1200	DRXM-48-535	88382	312.3
1350	DRXM-54-535	88386	353.2
1500	DRXM-60-535	88390	391.4
1800	DRXM-72-535	88394	447.7

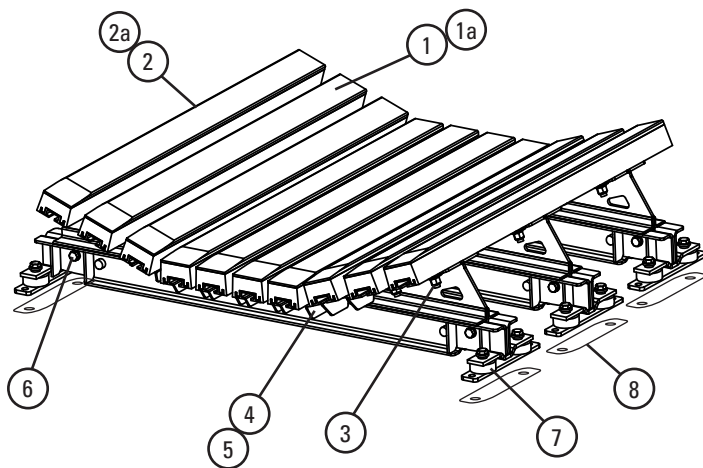

## Replacement Bars and Bolt Kits Required per Belt Width-DRX™750

BELT WIDTH	600	750	900	1050	1200	1350	1500	1800
mm								
No. Impact Bar Supports Required	4	4	5	6	6	6	7	8
No. Impact Bars Required	6	6	7	10	10	12	13	14
No. Impact Bar Bolt Kits Required	26	26	31	42	42	48	53	58

## Replacement Parts

REF	DESCRIPTION	ORDERING NUMBER	ITEM CODE	WT. KG
1	Impact Bar, 1.2M	IB4	76926	7.7
1a	Impact Bar, 1.5M	IB5	76927	9.6
2	Slider Bar, 1.2M	SB4	78789	9.0
2a	Slider Bar, 1.5M	SB5	78790	10.9
3	Impact Bar Bolt Kit incl. (1) ea 16mm carriage bolt, square washer, flat washer, lock washer, Nylock nut	IBBK	76928	0.2
4	Impact Bar Support - M 1.2M incl. (1) bar support, (2) ea carriage bolt, square washer, lock washer, Nylock nut	IBS-M4	76931	7.7
5	Impact Bar Support - M 1.5M incl. (1) bar support, (2) ea carriage bolt, square washer, lock washer, Nylock nut	IBS-M5	76932	9.6
6	Sliding Support Arm Bolt Kit incl. (2) 50mm bolts, (2) lock washers, (2) Nylock nuts	ISABK-LMH	77529	0.9
7	Isolation Mount Kit	IMK	76936	1.7
8	DRX™750 Shim Kit (incl. 6 shims)	SHIM-KITM	77549	9.3

Stock items (non-shaded) refer to (\*) for specific lead time, if not specified, standard lead time applies.  
Non-stock items (shaded) please contact Flexco for dispatch options and lead times.

# Product Ordering Information

## DRX™ 1500 Impact Beds

### DRX™1500 - 1.2 M Beds, 20° Trough

BELT WIDTH	ORDERING NUMBER	ITEM CODE	WT. KG
mm			
600	DRXH-24-420	81315	228.6
750	DRXH-30-420	81319	247.7
900	DRXH-36-420	81323	285.5
1050	DRXH-42-420	81327	366.4
1200	DRXH-48-420	81331	385.0
1350	DRXH-54-420	81335	444.1
1500	DRXH-60-420	81339	484.6
1800	DRXH-72-420	81343	550.0

### DRX™1500 - 1.2 M Beds, 35° Trough

BELT WIDTH	ORDERING NUMBER	ITEM CODE	WT. KG
mm			
600	DRXH-24-435	81317	228.6
750	DRXH-30-435	81321	247.7
900	DRXH-36-435	81325	285.5
1050	DRXH-42-435	81329	366.4
1200	DRXH-48-435	81333	385.0
1350	DRXH-54-435	81337	444.1
1500	DRXH-60-435	81341	484.6
1800	DRXH-72-435	81345	550.0

### DRX™1500 - 1.5 M Beds, 20° Trough

BELT WIDTH	ORDERING NUMBER	ITEM CODE	WT. KG
mm			
600	DRXH-24-520	81316	253.6
750	DRXH-30-520	81320	273.2
900	DRXH-36-520	81324	314.6
1050	DRXH-42-520	81328	407.3
1200	DRXH-48-520	81332	425.9
1350	DRXH-54-520	81336	492.7
1500	DRXH-60-520	81340	536.8
1800	DRXH-72-520	81344	606.4

### DRX™1500 - 1.5 M Beds, 35° Trough

BELT WIDTH	ORDERING NUMBER	ITEM CODE	WT. KG
mm			
600	DRXH-24-535	81318	253.6
750	DRXH-30-535	81322	273.2
900	DRXH-36-535	81326	314.6
1050	DRXH-42-535	81330	407.3
1200	DRXH-48-535	81334	425.9
1350	DRXH-54-535	81338	492.7
1500	DRXH-60-535	81342	536.8
1800	DRXH-72-535	81346	606.4

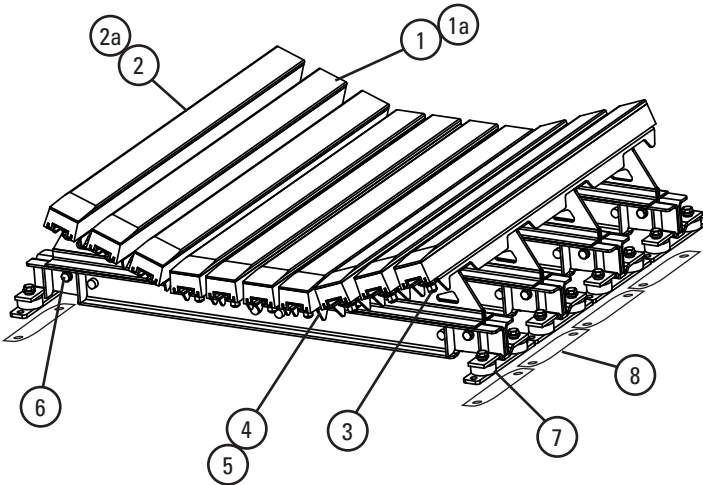

### Replacement Parts

REF	DESCRIPTION	ORDERING NUMBER	ITEM CODE	WT. KG
1	Impact Bar, 1.2M	IB4	76926	7.7
1a	Impact Bar, 1.5M	IB5	76927	9.6
2	Slider Bar, 1.2M	SB4	78789	9.0
2a	Slider Bar, 1.5M	SB5	78790	10.9
3	Impact Bar Bolt Kit incl. (1) ea 16mm carriage bolt, square washer, flat washer, lock washer, Nylock nut	IBBK	76928	0.2
4	Impact Bar Support -H 1.2M incl. (1) bar support, (2) ea carriage bolt, square washer, lock washer, Nylock nut	IBS-H4	76933	7.6
5	Impact Bar Support -DH 1.5M incl. (1) bar support, (2) ea carriage bolt, square washer, lock washer, Nylock nut	IBS-DH5	76934	9.6
6	Sliding Support Arm Bolt Kit incl. (2) 50mm bolts, (2) lock washers, (2) Nylock nuts	ISABK-LMH	77529	0.9
7	Isolation Mount Kit	IMK	76936	1.7
8	DRX™1500 Shim Kit (incl. 8 shims)	SHIM-KITH	77550	12.3

### Replacement Bars and Bolt Kits Required per Belt Width-DRX™1500

BELT WIDTH	600	750	900	1050	1200	1350	1500	1800
mm								
No. Impact Bar Supports Required	6	6	7	10	10	12	13	14
No. Impact Bars Required	6	6	7	10	10	12	13	14
No. Impact Bar Bolt Kits Required	36	36	42	60	60	72	78	84

Stock items (non-shaded) refer to (\*) for specific lead time, if not specified, standard lead time applies.  
Non-stock items (shaded) please contact Flexco for dispatch options and lead times.



# Product Ordering Information

**DRX™3000**  
Dynamic Beds

## DRX™3000 - 1.5 M Beds, 20° Trough

BELT WIDTH	ORDERING NUMBER	ITEM CODE	WT. KG
mm			
1050	DRXD-42-520	76912	614.1
1200	DRXD-48-520	76913	639.6
1350	DRXD-54-520	76914	712.7
1500	DRXD-60-520	76915	761.8
1800	DRXD-72-520	76916	953.6
2100	DRXD-84-520	76917	1027.7
2400	DRXD-96-520	76918	1185.9

## DRX™3000 - 1.5 M Beds, 35° Trough

BELT WIDTH	ORDERING NUMBER	ITEM CODE	WT. KG
mm			
1050	DRXD-42-535	76919	614.1
1200	DRXD-48-535	76920	639.6
1350	DRXD-54-535	76921	712.7
1500	DRXD-60-535	76922	761.8
1800	DRXD-72-535	76923	953.6
2100	DRXD-84-535	76924	1027.7
2400	DRXD-96-535	76925	1185.9

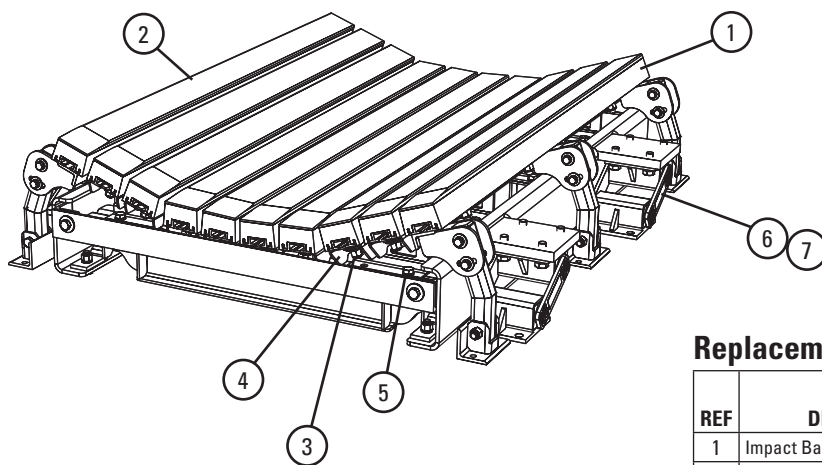

## Replacement Bars and Bolt Kits Required per Belt Width-DRX™3000

BELT WIDTH							
	1050	1200	1350	1500	1800	2100	2400
No. Impact Bars Required	10	10	12	13	16	16	20
No. Impact Bar Bolt Kits Required	56	56	64	70	88	88	112

## Replacement Parts

REF	DESCRIPTION	ORDERING NUMBER	ITEM CODE	WT. KG
1	Impact Bar, 1.5M	IB5	76927	9.6
2	Slider Bar, 1.5M	SB5	78790	10.9
3	Impact Bar Bolt Kit incl. (1) ea 16mm carriage bolt, square washer, flat washer, lock washer, Nylock nut	IBBK	76928	0.2
4	Impact Bar Support - DH 1.5M incl. (1) bar support, (2) ea carriage bolt, square washer, lock washer, Nylock nut	IBS-DH5	76934	9.6
5	Sliding Support Arm Bolt Kit incl. (4) 38mm bolts, (2) 51mm bolts, (6) lock washers, (6) Nylock nuts	ISABK	76935	0.9
6	Impact Energy Absorber 42-60	IEA42-60D	76937	19.1
7	Impact Energy Absorber 72-96	IEA72-96D	76938	30.0

## Impact Bar Supports per Belt Width

BELT WIDTH							
	1050	1200	1350	1500	1800	2100	2400
No. Impact Bar Supports	8	8	8	9	12	12	16

## Product Notes:

- For extreme impact applications up to 400 kgs.-M (lump size x drop height).
- Impact Energy Absorbers compress up to 75 mm to absorb extreme impact energy to minimize damaging forces and protect the belt.
- Slide-Out System™ allows direct access to service the impact bars.

Stock items (non-shaded) refer to (\*) for specific lead time, if not specified, standard lead time applies.  
Non-stock items (shaded) please contact Flexco for dispatch options and lead times.

# Product Ordering Information

## DRX™ Impact Beds Optional Parts and Tools

### Impact Bars with 25 mm UHMW

For impact beds that have heavy abrasive wear on the impact bars.

DESCRIPTION	ORDERING NUMBER	ITEM CODE	WT. KG
1.2M Impact Bar with 25mm UHMW	IB4-1U	76965	7.7
1.5M Impact Bar with 25mm UHMW	IB5-1U	76966	9.6

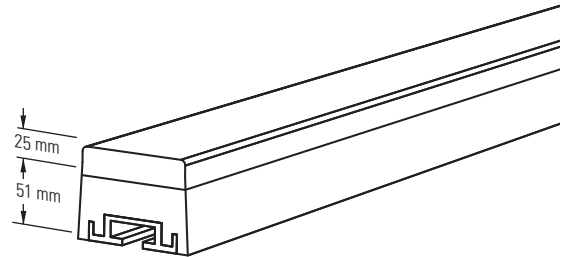

Impact Bar with 25 mm UHMW Cover

### Impact Bar Bolt Kit for Other OEM Impact Beds\*

13 mm carriage bolts, square washer, flat washer and Nylock nut to mount DRX Impact Bars on other OEM beds that use 13 mm T-bolts.

DESCRIPTION	ORDERING NUMBER	ITEM CODE	WT. KG
Optional Impact Bar Bolt Kit	OIBBK	76950	0.2

\*Kit includes 1 ea. bolt, square washer, flat washer and nut.

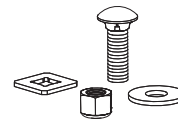

Optional Impact Bar Bolt Kit

### Impact Bed Handy Wrench

A ratcheting wrench with 2 common socket sizes 19 mm & 24 mm for installation and maintenance of impact beds.

DESCRIPTION	ORDERING NUMBER	ITEM CODE	WT. KG
Impact Bed Handy Wrench	HW-IMPB	76939	0.7

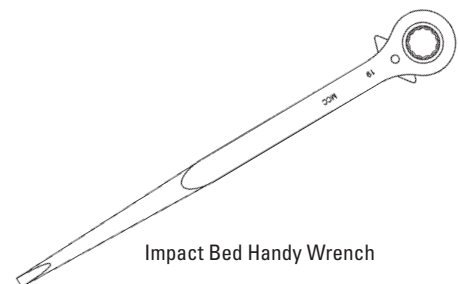

Impact Bed Handy Wrench

 **Stock items** (non-shaded) refer to (\*) for specific lead time, if not specified, standard lead time applies.

 **Non-stock items** (shaded) please contact Flexco for dispatch options and lead times.

# Product Ordering Information

## V-Plough

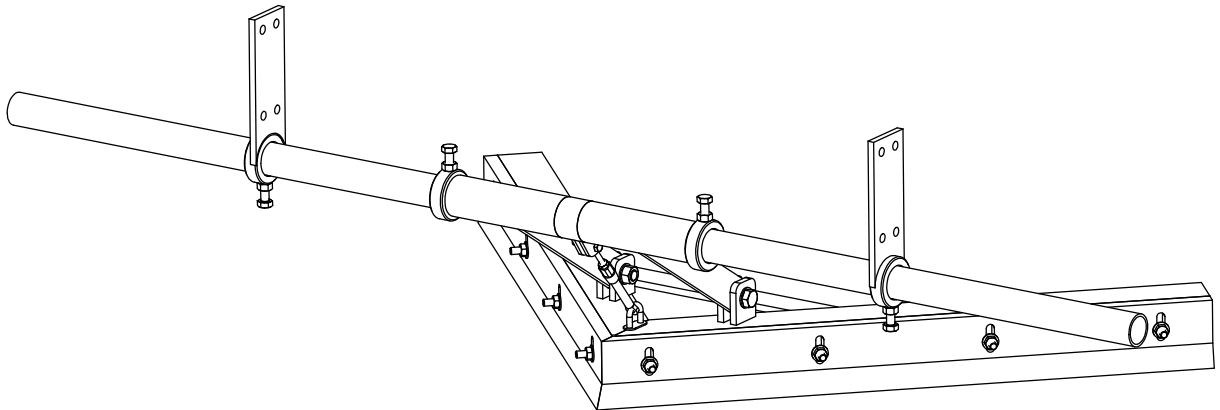

### Deflector™ V Plough-Mild Steel

BELT WIDTH	ORDERING NUMBER	ITEM CODE	WT. KG
mm			
450	BP450	73102	23
600	BP600	73104	25
750	BP750	73106	26
800	BP800	73107	28
900	BP900	73108	29
1050	BP1050	73110	31
1200	BP1200	73112	38
1400	BP1400	73113	42
1500	BP1500	73114	43
1600	BP1600	73115	44
1800	BP1800	73117	65

**Note:** Polyurethane Blades are approved for use in underground mines. For belt widths over 1800 mm contact Flexco.  
Lead time: 1 week

### Deflector™ V Plough-Stainless Steel

BELT WIDTH	ORDERING NUMBER	ITEM CODE	WT. KG
mm			
450	BP450-S/S	76337	24
600	BP600-S/S	76338	25
750	BP750-S/S	76339	27
800	BP800-S/S	76340	29
900	BP900-S/S	76341	30
1050	BP1050-S/S	76342	32
1200	BP1200-S/S	76343	39
1400	BP1400-S/S	76344	44
1500	BP1500-S/S	76345	45
1600	BP1600-S/S	76346	46
1800	BP1800-S/S	76347	67

**Note:** Polyurethane Blades are approved for use in underground mines. For belt widths over 1800 mm contact Flexco.  
Lead time: 1 week

### Product Notes:

- Exclusive blade design - 20° slant on leading edge spirals debris off the belt.
- Self-adjusting blade - the blade floats on the belt and self-adjusts as it wears.
- Unique blade adjuster - turnbuckle-type adjuster allows the blade to be accurately positioned to the belt.
- Easy to install - comes fully assembled and can be placed right into position on the conveyor.

Stock items (non-shaded) refer to (\*) for specific lead time, if not specified, standard lead time applies.  
Non-stock items (shaded) please contact Flexco for dispatch options and lead times.

# Replacement Parts List

V-Plough

Replacement Parts		POWDER COATED			STAINLESS STEEL		
DESCRIPTION	BELT WIDTH	ORDERING NUMBER	ITEM CODE	WT. KG	ORDERING NUMBER	ITEM CODE	WT. KG
	mm						
PL Pole	450-750	BP450-750-PL	73109	2.8	BP450-750-PL-S/S	A0683	2.7
	800-1050	BP800-1050-PL	73111	3.2	BP800-1050-PL-S/S	A0613	3.2
	1200-1400	BP1200-1400-PL	73118	3.6	BP1200-1400-PL-S/S	A0621	3.6
	1500-1600	BP1500-1600-PL	73119	4.6	BP1500-1600-PL-S/S	A0647	5.0
	1800	BP1800-PL	73121	5.5	BP1800-PL-S/S	A1547	5.9
Frame	450-750	BP450-750MF	73152	6.7	BP450-750MF-S/S MAIN FRAME	A0682	6.7
	800-1050	BP800-1050MF	73153	9.8	BP800-1050MF-S/S MAIN FRAME	A0612	9.8
	1200-1400	BP1200-1400MF	73154	12.6	BP1200-1400MF-S/S MAIN FRAME	A0620	12.6
	1500-1600	BP1500-1600MF	73147	16.0	BP1500-1600MF-S/S MAIN FRAME	A0646	16.0
	1800	BP1800MF	73148	18.3	BP1800MF-S/S MAIN FRAME	A1546	18.3
	2000	BP2000MF	A1996	19.7			
Blades - Polyurethane Pair - 110mm	450	BP450-B	74055	0.9			
	600	BP600-B	73777	0.9			
	750	BP750-B	73778	1.8			
	800	BP800-B	74057	1.8			
	900	BP900-B	73779	1.8			
	1050	BP1050-B	73780	1.8			
	1200	BP1200-B	73781	1.8			
	1400	BP1400-B	73782	2.3			
	1500	BP1500-B	73783	2.7			
	1600	BP1600-B	73784	2.7			
Blades - Polyurethane Pair - 180mm (Heavy-Duty)	1800	BP1800-B	73785	3.2			
	750	HBP750-B	A0223	5.2			
	900	HBP900-B	A0224	6.3			
	1050	HBP1050-B	A2237	7.2			
	1200	HBP1200-B	73301	8.4			
	1400	HBP1400-B	73302	9.7			
	1500	HBP1500-B	73303	10.6			
	1600	HBP1600-B	73304	11.6			
	1800	HBP1800-B	73306	13.0			
	2000	HBP2000-B	73307	14.5			
2200	HBP2200-B	73308	15.9				
2400	HBP2400-B	73309	16.9				
2500	HBP2500-B	73311	17.8				
Mounting Bracket		BP-MB	73123	0.5	BP-MB-S/S	A0615	0.5
Shaft Collar		BP-SC	73125	0.5	BP-SC-S/S	A0616	0.5
Linkage Arm		BP-LA	73127	0.9	BP-LA-S/S	A0614	0.9
Turnbuckle Linkage		BP-TL	73141	0.5	BP-TL-S/S	A0617	0.5
Standard Turnbuckle					BP-TB	73138	0.5
Standard U-Bolt					BP-UB	73139	0.5

Lead time: 3 weeks

Stock items (non-shaded) refer to (\*) for specific lead time, if not specified, standard lead time applies.  
 Non-stock items (shaded) please contact Flexco for dispatch options and lead times.

# Product Ordering Information

## Twin Pole V-Plough



### Deflector™ Twin Pole V Plough - Mild Steel UHMPE Blade

BELT WIDTH	ORDERING NUMBER	ITEM CODE	WT. KG
mm			
900	HBP900-TP	A2283	93.0
1050	HBP1050-TP	A2284	99.0
1200	HBP1200-TP	A2285	106.0
1400	HBP1400-TP	A2286	115.0
1500	HBP1500-TP	A2287	119.0
1600	HBP1600-TP	A2288	124.0
1800	HBP1800-TP	A2289	133.0
2000	HBP2000-TP	A2290	142.0
2200	HBP2200-TP	A2291	151.0
2400	HBP2400-TP	A2292	162.0
2500	HBP2500-TP	A2293	165.0

**Note:** Scraping blades are UHMPE material. Blades are not FRAS approved. For belt widths over 2500 mm contact Flexco. Lead time: 4 weeks

### Deflector™ Twin Pole V Plough - Stainless Steel UHMPE Blade

BELT WIDTH	ORDERING NUMBER	ITEM CODE	WT. KG
mm			
900	HBP-TP-900 S/S	A2474	94.0
1050	HBP-TP-1050 S/S	A2475	100.0
1200	HBP-TP-1200 S/S	A2476	107.0
1400	HBP-TP-1400 S/S	A2477	116.0
1500	HBP-TP-1500 S/S	A2478	120.0
1600	HBP-TP-1600 S/S	A2479	125.0
1800	HBP-TP-1800 S/S	A2480	134.0
2000	HBP-TP-2000 S/S	A2481	143.0
2200	HBP-TP-2200 S/S	A2482	152.0
2400	HBP-TP-2400 S/S	A2483	163.0
2500	HBP-TP-2500 S/S	A2484	166.0

**Note:** Scraping blades are UHMPE material. Blades are not FRAS approved. For belt widths over 2500 mm contact Flexco. Lead time: 4 weeks

Stock items (non-shaded) refer to (\*) for specific lead time, if not specified, standard lead time applies.  
 Non-stock items (shaded) please contact Flexco for dispatch options and lead times.

# Replacement Parts List

## Twin Pole V-Plough

Replacement Parts		POWDER COATED			STAINLESS STEEL		
DESCRIPTION	BELT WIDTH	ORDERING NUMBER	ITEM CODE	WT. KG	ORDERING NUMBER	ITEM CODE	WT. KG
	mm						
PL Pole	900	HBP900-PL-TP	A2294	14.0	HBP900-PL-TP-S/S	A2492	15.0
	1050	HBP1050-PL-TP	A2295	15.0	HBP1050-PL-TP-S/S	A2493	16.0
	1200	HBP1200-PL-TP	A2296	16.0	HBP1200-PL-TP-S/S	A2494	17.0
	1400	HBP1400-PL-TP	A2297	18.0	HBP1400-PL-TP-S/S	A2495	19.0
	1500	HBP1500-PL-TP	A2298	20.0	HBP1500-PL-TP-S/S	A2496	21.0
	1600	HBP1600-PL-TP	A2299	21.0	HBP1600-PL-TP-S/S	A2497	22.0
	1800	HBP1800-PL-TP	A2300	22.0	HBP1800-PL-TP-S/S	A2498	23.0
	2000	HBP2000-PL-TP	A2301	24.0	HBP2000-PL-TP-S/S	A2499	25.0
	2200	HBP2200-PL-TP	A2303	26.0	HBP2200-PL-TP-S/S	A2500	27.0
	2400	HBP2400-PL-TP	A2302	28.0	HBP2400-PL-TP-S/S	A2501	29.0
	2500	HBP2500-PL-TP	A2304	29.0	HBP2500-PL-TP-S/S	A2502	30.0
Frame	900	HBP900-MF-TP	A2305	26.0	HBP900-MF-TP-S/S	A2504	27.0
	1050	HBP1050-MF-TP	A2306	28.0	HBP1050-MF-TP-S/S	A2505	29.0
	1200	HBP1200-MF-TP	A2307	30.0	HBP1200-MF-TP-S/S	A2506	31.0
	1400	HBP1400-MF-TP	A2308	33.0	HBP1400-MF-TP-S/S	A2507	34.0
	1500	HBP1500-MF-TP	A2309	34.0	HBP1500-MF-TP-S/S	A2508	35.0
	1600	HBP1600-MF-TP	A2310	35.5	HBP1600-MF-TP-S/S	A2509	36.5
	1800	HBP1800-MF-TP	A2311	38.0	HBP1800-MF-TP-S/S	A2510	39.0
	2000	HBP2000-MF-TP	A2312	41.0	HBP2000-MF-TP-S/S	A2511	42.0
	2200	HBP2200-MF-TP	A2314	44.0	HBP2200-MF-TP-S/S	A2512	45.0
	2400	HBP2400-MF-TP	A2313	52.0	HBP2400-MF-TP-S/S	A2513	53.0
	2500	HBP2500-MF-TP	A2315	54.0	HBP2500-MF-TP-S/S	A2514	55.0
Blades	900	HBP900-B-TP	A2316	4.5			
	1050	HBP1050-B-TP	A2317	5.0			
	1200	HBP1200-B-TP	A2318	5.5			
	1400	HBP1400-B-TP	A2319	6.3			
	1500	HBP1500-B-TP	A2320	7.0			
	1600	HBP1600-B-TP	A2321	7.5			
	1800	HBP1800-B-TP	A2322	8.2			
	2000	HBP2000-B-TP	A2323	9.0			
	2200	HBP2200-B-TP	A2325	9.8			
	2400	HBP2400-B-TP	A2324	10.7			
	2500	HBP2500-B-TP	A2326	11.2			
Linkage Arm	900-2500	HBP-LA-TP	A2330	5.0	HBP-LA-TP-S/S	A2515	5.0
Mounting Bracket	900-2500	HBP-MB-TP	73922	2.1	HBP-MB-TP-S/S	A1155	2.1
Shaft Collar	900-2500	HBP-SC-TP	74490	0.7	HBP-SC-TP-S/S	A2189	0.7

Lead time: 4 weeks

Stock items (non-shaded) refer to (\*) for specific lead time, if not specified, standard lead time applies.  
 Non-stock items (shaded) please contact Flexco for dispatch options and lead times.

# Product Ordering Information

## V-Plough Blade Kits



### V-Plough Blade Kits

DESCRIPTION	ORDERING NUMBER	ITEM CODE	WT. KG
<b>Standard-Duty Kits</b>			
RVBP-SD-600-KIT VPLOUGH BLADE KIT	RBVP-SD-600	68267	5.6
RVBP-SD-750-KIT VPLOUGH BLADE KIT	RBVP-SD-750	68268	6.5
RVBP-SD-900-KIT VPLOUGH BLADE KIT	RBVP-SD-900	68269	7.5
RVBP-SD-1050-KIT VPLOUGH BLADE KIT	RBVP-SD-1050	68270	8.1
RVBP-SD-1200-KIT VPLOUGH BLADE KIT	RBVP-SD-1200	68271	8.9
RVBP-SD-1350-KIT VPLOUGH BLADE KIT	RBVP-SD-1350	68272	10.1
RVBP-SD-1500-KIT VPLOUGH BLADE KIT	RBVP-SD-1500	68273	12.6
RVBP-SD-1800-KIT VPLOUGH BLADE KIT	RBVP-SD-1800	68274	13.0
RVBP-SD-2000-KIT VPLOUGH BLADE KIT	RBVP-SD-2000	68275	14.2
RVBP-SD-2200-KIT VPLOUGH BLADE KIT	RBVP-SD-2200	68276	15.5
RVBP-SD-2400-KIT VPLOUGH BLADE KIT	RBVP-SD-2400	68277	16.7
RVBP-SD-2600-KIT VPLOUGH BLADE KIT	RBVP-SD-2600	68278	17.9
RVBP-SD-2800-KIT VPLOUGH BLADE KIT	RBVP-SD-2800	68279	19.2
<b>Heavy-Duty Kits</b>			
RVBP-HD-900-KIT VPLOUGH BLADE KIT	RBVP-HD-900	68252	37.3
RVBP-HD-1050-KIT VPLOUGH BLADE KIT	RBVP-HD-1050	68253	69.6
RVBP-HD-1200-KIT VPLOUGH BLADE KIT	RBVP-HD-1200	68254	79.5
RVBP-HD-1350-KIT VPLOUGH BLADE KIT	RBVP-HD-1350	68255	107.8
RVBP-HD-1500-KIT VPLOUGH BLADE KIT	RBVP-HD-1500	68256	119.8
RVBP-HD-1600-KIT VPLOUGH BLADE KIT	RBVP-HD-1600	68257	127.8
RVBP-HD-1800-KIT VPLOUGH BLADE KIT	RBVP-HD-1800	68258	159.0
RVBP-HD-2000-KIT VPLOUGH BLADE KIT	RBVP-HD-2000	68259	176.6
RVBP-HD-2200-KIT VPLOUGH BLADE KIT	RBVP-HD-2200	68260	194.3
RVBP-HD-2400-KIT VPLOUGH BLADE KIT	RBVP-HD-2400	68261	212.0
RVBP-HD-2500-KIT VPLOUGH BLADE KIT	RBVP-HD-2500	68262	220.8
RVBP-HD-2600-KIT VPLOUGH BLADE KIT	RBVP-HD-2600	68263	229.6
RVBP-HD-2800-KIT VPLOUGH BLADE KIT	RBVP-HD-2800	68264	247.3
RVBP-HD-3000-KIT VPLOUGH BLADE KIT	RBVP-HD-3000	68265	265.0
RVBP-HD-3200-KIT VPLOUGH BLADE KIT	RBVP-HD-3200	68266	282.6

### Product Notes:

- Lasts up to 12 months longer than the leading competitor blade.
- Can be retrofitted to existing ESS V-Ploughs. The design of the blades allows a simple retrofit to existing ploughs.
- Simple and quick replacement for new blades. Due to the simple cartridge design of the blades, the replacement of blades is a quick and simple job, reducing the down time required.
- Discharges to both sides of the belt. The plough is angled to discharge materials to both sides of the belt, making it as convenient as possible for cleanup.
- Reduces belt mistracking.
- Use 93A durometer polyurethane to ensure exceptional wear life.

**Stock items** (non-shaded) refer to (\*) for specific lead time, if not specified, standard lead time applies.
   
 **Non-stock items** (shaded) please contact Flexco for dispatch options and lead times.



# Product Ordering Information

## V-Plough Blade Kits

### Replacement Parts

DESCRIPTION	ORDERING NUMBER	ITEM CODE	WT. KG
<b>Nose Cones</b>			
RBVP-SD-N SD VPLOUGH NOSE	RBVP-SD-N	91768	2.0
RBVP-HD-N HD VPLOUGH NOSE	RBVP-HD-N	91782	6.9
<b>Standard-Duty</b>			
RBVP-SD-S-600 SD VPLOUGH SIDE	RBVP-SD-S-600	91769	1.8
RBVP-SD-S-750 SD VPLOUGH SIDE	RBVP-SD-S-750	91770	2.3
RBVP-SD-S-900 SD VPLOUGH SIDE	RBVP-SD-S-900	91771	2.8
RBVP-SD-S-1050 SD VPLOUGH SIDE	RBVP-SD-S-1050	91772	3.0
RBVP-SD-S-1200 SD VPLOUGH SIDE	RBVP-SD-S-1200	91773	3.4
RBVP-SD-S-1350 SD VPLOUGH SIDE	RBVP-SD-S-1350	91774	4.1
RBVP-SD-S-1500 SD VPLOUGH SIDE	RBVP-SD-S-1500	91775	5.3
RBVP-SD-S-1800 SD VPLOUGH SIDE	RBVP-SD-S-1800	91776	5.5
RBVP-SD-S-2000 SD VPLOUGH SIDE	RBVP-SD-S-2000	91777	6.1
RBVP-SD-S-2200 SD VPLOUGH SIDE	RBVP-SD-S-2200	91778	6.7
RBVP-SD-S-2400 SD VPLOUGH SIDE	RBVP-SD-S-2400	91779	7.4
RBVP-SD-S-2600 SD VPLOUGH SIDE	RBVP-SD-S-2600	91780	8.0
RBVP-SD-S-2800 SD VPLOUGH SIDE	RBVP-SD-S-2800	91781	8.6
<b>Heavy-Duty</b>			
RBVP-HD-S-900 HD VPLOUGH SIDE	RBVP-HD-S-900	91783	2.7
RBVP-HD-S-1050 HD VPLOUGH SIDE	RBVP-HD-S-1050	91784	5.0
RBVP-HD-S-1200 HD VPLOUGH SIDE	RBVP-HD-S-1200	91785	5.8
RBVP-HD-S-1350 HD VPLOUGH SIDE	RBVP-HD-S-1350	91786	7.8
RBVP-HD-S-1500 HD VPLOUGH SIDE	RBVP-HD-S-1500	91787	8.7
RBVP-HD-S-1600 HD VPLOUGH SIDE	RBVP-HD-S-1600	91788	9.3
RBVP-HD-S-1800 HD VPLOUGH SIDE	RBVP-HD-S-1800	91789	11.5
RBVP-HD-S-2000 HD VPLOUGH SIDE	RBVP-HD-S-2000	91790	12.8
RBVP-HD-S-2200 HD VPLOUGH SIDE	RBVP-HD-S-2200	91791	14.1
RBVP-HD-S-2400 HD VPLOUGH SIDE	RBVP-HD-S-2400	91792	15.4
RBVP-HD-S-2500 HD VPLOUGH SIDE	RBVP-HD-S-2500	91793	16.0
RBVP-HD-S-2600 HD VPLOUGH SIDE	RBVP-HD-S-2600	91794	16.6
RBVP-HD-S-2800 HD VPLOUGH SIDE	RBVP-HD-S-2800	91795	17.9
RBVP-HD-S-3000 HD VPLOUGH SIDE	RBVP-HD-S-3000	91796	19.2
RBVP-HD-S-3200 HD VPLOUGH SIDE	RBVP-HD-S-3200	91797	20.5



V-Plough SD Nose



V-Plough SD Side



V-Plough HD Nose



V-Plough HD Side

 **Stock items** (non-shaded) refer to (\*) for specific lead time, if not specified, standard lead time applies.

 **Non-stock items** (shaded) please contact Flexco for dispatch options and lead times.

# Product Ordering Information

## Diagonal Plough

### Diagonal Ploughs - Mild Steel\*

BELT WIDTH	ORDERING NUMBER	ITEM CODE	WT. KG
mm			
450-750	CBD-S	76442	20.0
900-1050	CBD-M	76443	25.0
1200-1500	CBD-L	76444	32.0
1600-1800	CBD-XL	76445	43.0
2000-2400	CBD-XXL	64787	54.0

\*Size up for belt widths between ranges.



### Diagonal Plough\* - Stainless Steel\*

BELT WIDTH	ORDERING NUMBER	ITEM CODE	WT. KG
mm			
450-750	CBD-S-S/S	64178	20.0
900-1050	CBD-M-S/S	A1854	25.0
1200-1500	CBD-L-S/S	A1856	32.0
1600-1800	CBD-XL-S/S	76318	43.0
2000-2400	CBD-XXL-S/S	63554	54.0

\*Size up for belt widths between ranges.

### Replacement Blade Kits - Polyurethane Blades

BELT WIDTH	ORDERING NUMBER	ITEM CODE	WT. KG
mm			
450-750	DBK-S	76446	2.0
900-1050	DBK-M	76447	3.0
1200-1500	DBK-L	76448	4.0
1600-1800	DBK-XL	76449	5.0
2000-2400	DBK-XXL	62595	6.0

Diagonal Plough requires 1 blade; Reversing Plough requires 2 blades.

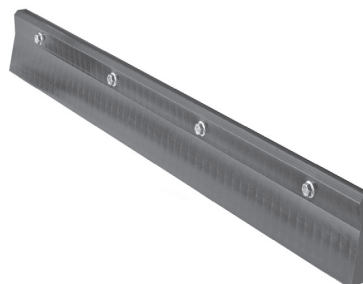

### Dual Blade Reversing Plough - Mild Steel & Polyurethane Blades

BELT WIDTH	ORDERING NUMBER	ITEM CODE	WT. KG
mm			
450-750	CBR-S	72483	40.0
900-1050	CBR-M	72484	48.0
1200-1500	CBR-L	72485	60.0
1600-2000	CBR-XL	72486	80.0

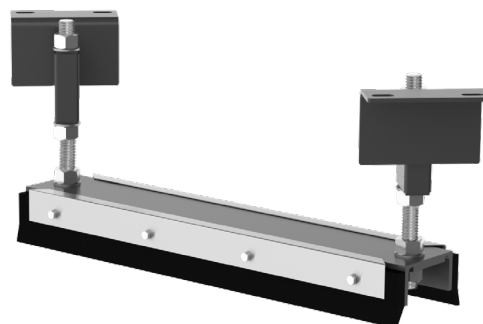

### Product Notes:

- A belt cleaner for the tail pulley. Prevents damage to the belt, pulley, lagging, and belt splice.
- Keeps fugitive materials off the inside of the belt and out of the tail pulley.
- Installed at a 45° angle across the belt to discharge material to one predetermined side.
- The blade is installed in a fixed position, eliminating any bouncing problems.
- Exclusive 20° angled blade quickly spirals material off the belt.

 Stock items (non-shaded) refer to (\*) for specific lead time, if not specified, standard lead time applies.

 Non-stock items (shaded) please contact Flexco for dispatch options and lead times.

# Product Ordering Information & Replacement Parts

## Diagonal Plough HD Spring Tensioned

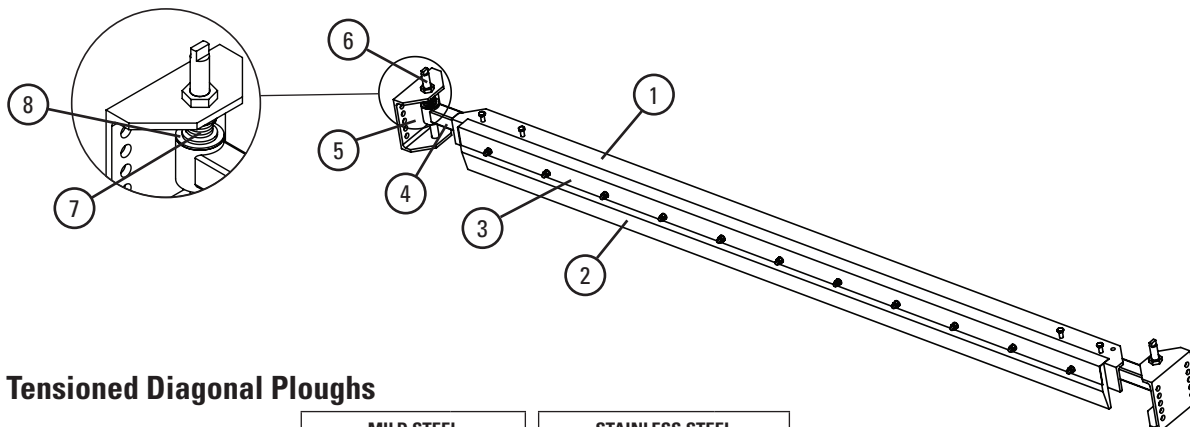

### HD Spring Tensioned Diagonal Ploughs

DESCRIPTION	BELT WIDTH mm	MILD STEEL		STAINLESS STEEL	
		ORDERING NUMBER	ITEM CODE	ORDERING NUMBER	ITEM CODE
Heavy-Duty Spring Tensioned Diagonal Plough with Standard Blade (FRAS)	900-1050	CBD-ST-M	61077	CBD-ST-M-S/S	61079
	1200-1500	CBD-ST-L	61050	CBD-ST-L-S/S	61080
	1600-1800	CBD-ST-XL	61051	CBD-ST-XL-S/S	A2138
	2000-2400	CBD-ST-XXL	63747	CBD-ST-XXL-S/S	63748
Heavy-Duty Spring Tensioned Diagonal Plough with Polyurethane Blade	900-1050	CBD-ST-M-P	64772	CBD-ST-M-P-S/S	64623
	1200-1500	CBD-ST-L-P	64773	CBD-ST-L-P-S/S	64624
	1600-1800	CBD-ST-XL-P	64774	CBD-ST-XL-P-S/S	64625
	2000-2400	CBD-ST-XXL-P	64775	CBD-ST-XXL-P-S/S	64626
Heavy-Duty Spring Tensioned Diagonal Plough with Polyurethane Blade and Shield	900-1050	CBD-ST-M-PSS	64776	CBD-ST-M-PS-S/S	64780
	1200-1500	CBD-ST-L-PS	64777	CBD-ST-L-PS-S/S	64781
	1600-1800	CBD-ST-XL-PS	64778	CBD-ST-XL-PS-S/S	64782
	2000-2400	CBD-ST-XXL-PS	64779	CBD-ST-XXL-PS-S/S	64783

Lead time: 4 weeks

### Replacement Parts

REF	DESCRIPTION	BELT WIDTH mm	BLADE WIDTH mm	MILD STEEL		STAINLESS STEEL	
				ORDERING NUMBER	ITEM CODE	ORDERING NUMBER	ITEM CODE
1	Diagonal Plough Main Frame	900-1050	N/A	CBD-ST-M-MF	61105	CBD-ST-M-MF-S/S	61108
		1200-1500	N/A	CBD-ST-L-MF	61106	CBD-ST-L-MF-S/S	61109
		1600-1800	N/A	CBD-ST-XL-MF	61107	CBD-ST-XL-MF-S/S	61110
		2000-2400	N/A	CBD-ST-XXL-MF	63749	CBD-ST-XXL-MF-S/S	63750
2	Standard Blade (FRAS)	900-1050	1750	CBD-ST-FR-B	61111		
		1200-1500	2250	CBD-ST-L-FR-B	A2218		
		1600-1800	2750	CBD-ST-XL-FR-B	A1784		
		2000-2400	3250	CBD-ST-XXL-FR-B	63752		
	Heavy-Duty Polyurethane Blade	900-1050	1750	CBD-ST-B	64620		
		1200-1500	2250	CBD-ST-L-B	64621		
		1600-1800	2750	CBD-ST-XL-B	64482		
		2000-2400	3250	CBD-ST-XXL-B	64622		
3	Stainless Steel Face Plate	900-1050	N/A	CBD-ST-M-FP	61112		
		1200-1500	N/A	CBD-ST-L-FP	61113		
		1600-1800	N/A	CBD-ST-XL-FP	61114		
		2000-2400	N/A	CBD-ST-XXL-FP	63751		
-	Diagonal Plough Shields	900-1050	N/A	CBD-ST-M-S	63706		
		1200-1500	N/A	CBD-ST-L-S	63707		
		1600-1800	N/A	CBD-ST-XL-S	63024		
		2000-2400	N/A	CBD-ST-XXL-S	63791		
4	Adjusting Arm		N/A	CBD-ST-AA	61096		
5	Mounting Channel		N/A	CBD-ST-MC	B0092		
6	Threaded Bar		N/A	CBD-ST-TB-S/S	A2629		
7	Compression Spring		N/A	CBD-ST-CS-S/S	A2215		
8	Bush with Brass Insert			CBD-ST-BB	64310		

Lead time: 4 weeks

# Product Ordering Information

## MXDP Diagonal Plough

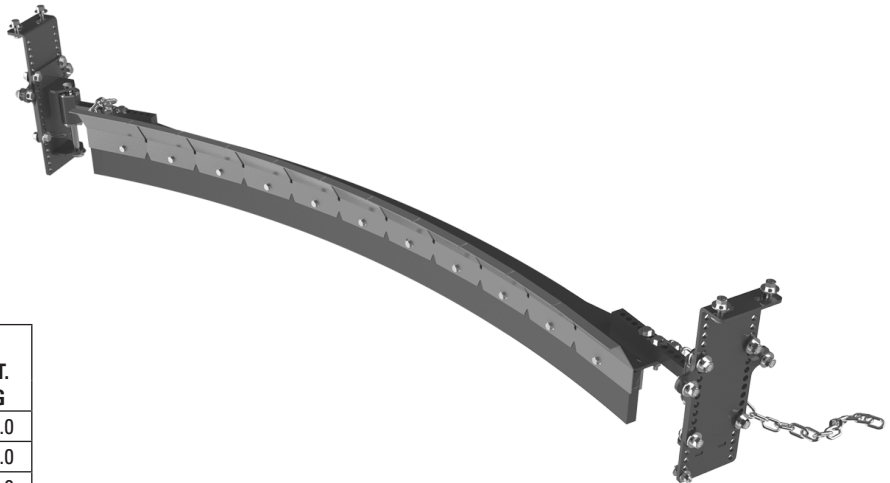

### MXDP Diagonal Plough

BELT WIDTH	ORDERING NUMBER	ITEM CODE	WT. KG
mm			
1200	MXDP-48/1200	106063	90.0
1350	MXDP-54/1350	106064	94.0
1500	MXDP-60/1500	106065	98.0
1650	MXDP-66/1650	106066	101.0
1800	MXDP-72/1800	106067	105.0
1950	MXDP-78/1950	106068	109.0
2100	MXDP-84/2100	106069	113.0
2400	MXDP-96/2400	106070	121.0
2700	MXDP-108/2700	106071	128.0
3000	MXDP-120/3000	106072	136.0

Lead time: 12 weeks

### MXDP Diagonal Plough with Hungry Board

BELT WIDTH	ORDERING NUMBER	ITEM CODE	WT. KG
mm			
1200	MXDP-48/1200-H	106265	99.0
1350	MXDP-54/1350-H	106266	104.0
1500	MXDP-60/1500-H	106267	108.0
1650	MXDP-66/1650-H	106268	113.0
1800	MXDP-72/1800-H	106269	118.0
1950	MXDP-78/1950-H	106270	123.0
2100	MXDP-84/2100-H	106271	127.0
2400	MXDP-96/2400-H	106272	137.0
2700	MXDP-108/2700-H	106273	147.0
3000	MXDP-120/3000-H	106274	156.0

Lead time: 12 weeks

### Replacement Blades

BELT WIDTH	ORDERING NUMBER	ITEM CODE	WT. KG
mm			
1200	MXDPB-48/1200	106122	12.0
1350	MXDPB-54/1350	106123	13.0
1500	MXDPB-60/1500	106124	14.0
1650	MXDPB-66/1650	106125	15.0
1800	MXDPB-72/1800	106126	17.0
1950	MXDPB-78/1950	106127	18.0
2100	MXDPB-84/2100	106128	20.0
2400	MXDPB-96/2400	106129	22.0
2700	MXDPB-108/2700	106130	24.0
3000	MXDPB-120/3000	106131	27.0

Lead time: 12 weeks

### Product Notes:

- A belt cleaner for the tail pulley. Prevents damage to the belt, pulley, lagging, and belt splice.
- Keeps fugitive materials off the inside of the belt and out of the tail pulley.
- Installed at a 45° angle across the belt to discharge material to one predetermined side.
- Safety chain included.

Stock items (non-shaded) refer to (\*) for specific lead time, if not specified, standard lead time applies.  
 Non-stock items (shaded) please contact Flexco for dispatch options and lead times.

# Replacement Parts List

## MXDP Diagonal Plough

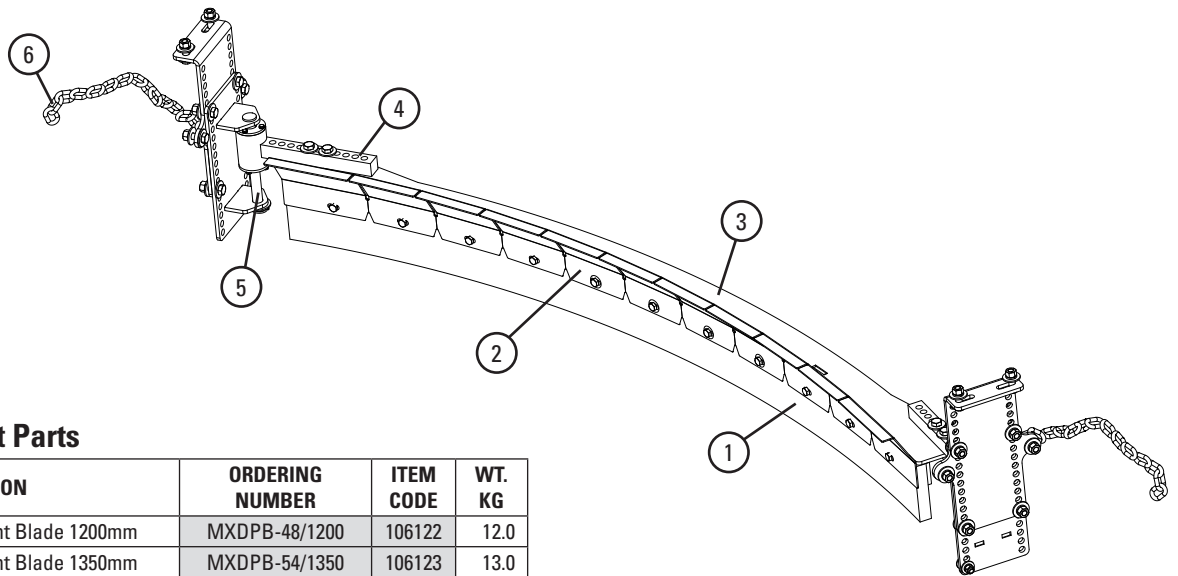

### Replacement Parts

REF	DESCRIPTION	ORDERING NUMBER	ITEM CODE	WT. KG
1	Replacement Blade 1200mm	MXDPB-48/1200	106122	12.0
	Replacement Blade 1350mm	MXDPB-54/1350	106123	13.0
	Replacement Blade 1500mm	MXDPB-60/1500	106124	14.0
	Replacement Blade 1650mm	MXDPB-66/1650	106125	15.0
	Replacement Blade 1800mm	MXDPB-72/1800	106126	17.0
	Replacement Blade 1950mm	MXDPB-78/1950	106127	18.0
	Replacement Blade 2100mm	MXDPB-84/2100	106128	20.0
	Replacement Blade 2400mm	MXDPB-96/2400	106129	22.0
	Replacement Blade 2700mm	MXDPB-108/2700	106130	24.0
	Replacement Blade 3000mm	MXDPB-120/3000	106131	27.0
2	Hungry Board 1200mm	MXDPH-48/1200	106106	9.0
	Hungry Board 1350mm	MXDPH-54/1350	106107	10.0
	Hungry Board 1500mm	MXDPH-60/1500	106108	11.0
	Hungry Board 1650mm	MXDPH-66/1650	106109	12.0
	Hungry Board 1800mm	MXDPH-72/1800	106110	13.0
	Hungry Board 1950mm	MXDPH-78/1950	106111	14.0
	Hungry Board 2100mm	MXDPH-84/2100	106112	15.0
	Hungry Board 2400mm	MXDPH-96/2400	106113	16.0
	Hungry Board 2700mm	MXDPH-108/2700	106114	19.0
Hungry Board 3000mm	MXDPH-120/3000	106115	20.0	
3	Frame 1200mm	MXDPF-48/1200	106634	24.0
	Frame 1350mm	MXDPF-54/1350	106635	27.0
	Frame 1500mm	MXDPF-60/1500	106636	29.0
	Frame 1650mm	MXDPF-66/1650	106637	32.0
	Frame 1800mm	MXDPF-72/1800	106638	34.0
	Frame 1950mm	MXDPF-78/1950	106639	37.0
	Frame 2100mm	MXDPF-84/2100	106640	39.0
	Frame 2400mm	MXDPF-96/2400	106641	44.0
	Frame 2700mm	MXDPF-108/2700	106642	49.0
	Frame 3000mm	MXDPF-120/3000	106643	54.0
4	Mounting Arm Kit (1 ea.; hardware included)	MXDP-MAK	106095	12.0
5	Mounting Pin Kit (1 ea.; hardware included)	MXDP-MPK	106548	1.0
6	Safety Chain Kit (1 ea.; hardware included)	MXCP-SCK	106624	2.0
-	Mounting Kit - Complete (incl. 2 ea. mounting plates, 4, 5, 6)	MXDP-MK	106549	52.0

Lead time: 12 weeks

**Stock items** (non-shaded) refer to (\*) for specific lead time, if not specified, standard lead time applies.  
 **Non-stock items** (shaded) please contact Flexco for dispatch options and lead times.

# Product Ordering Information

**Belt Positioner™**

**Note:**

- Use next larger size for belt widths between ranges.
- Idler rollers on sizes:
  - S-M-L are 127 mm diameter
  - X are are 152 mm diameter
- Finish: All steel parts are powder coated. All nuts and set screws are metric in 300 series Stainless Steel.
- This product is also available in Stainless Steel. Please contact Flexco for pricing.

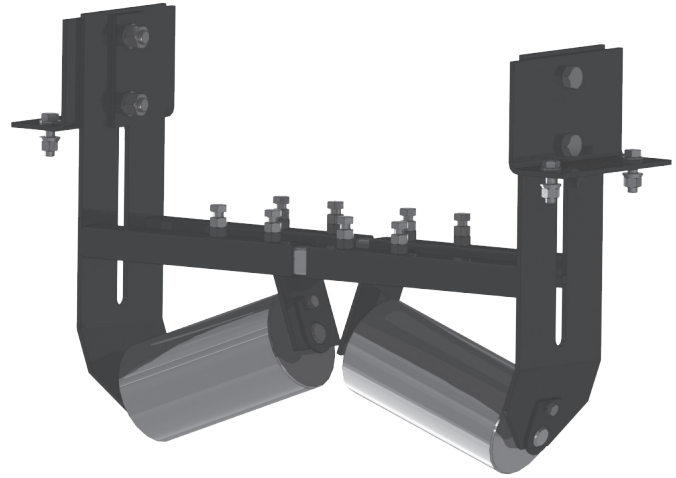

**Belt Positioners with Steel Rollers**

SIZE	BELT WIDTH (MIN-MAX)	POSITIONER WIDTH (MIN-MAX)	ORDERING NUMBER	ITEM CODE	WT. KG
	mm	mm			
Small	450-600	600-850	PSR-S-F	105629	31.7
Medium	750-1200	850-1400	PSR-M-F	105630	38.5
Large	1350-1800	1400-2075	PSR-L-F	105631	49.8
Extra Large	1800-2400	1800-3000	PSR-XL-F	105632	90.7

Lead time: 4 weeks

**Product Notes:**

- The Positioner should be centered between two standard return rollers. For general applications-standard belts up to 1800 mm: position the unit no closer than 900 mm to a return roller and no farther than 1.8 meters.
- Works on the return side of the conveyor using simple angled rollers mounted in a fixed position to quickly and continuously funnel the belt into the correct path.
- A “quick fix” solution for belts that consistently wander to one side.
- Typically installed before the tail pulley to keep the belt centred at the critical loading point. Centre loading is the key to solving many top side tracking problems.
- Idler rollers make smooth contact with the return belt’s bottom cover, eliminating excessive wear and damage to the belt’s edges.
- Has no pivoting mechanism to freeze up and cause the unit to stop working.
- Once installed, no further adjustment is required.

**Stock items** (non-shaded) refer to (\*) for specific lead time, if not specified, standard lead time applies.  
 **Non-stock items** (shaded) please contact Flexco for dispatch options and lead times.

# Replacement Parts List

**Belt Positioner™**

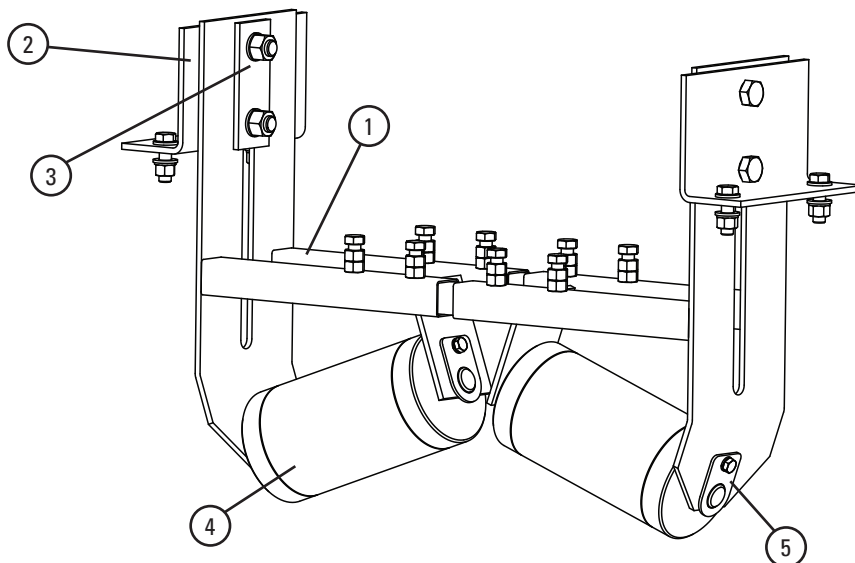

## Replacement Parts

REF	DESCRIPTION	BELT WIDTH (MIN-MAX)	ORDERING NUMBER	ITEM CODE	WT. KG
		mm			
1	Small Frame Kit* (1 ea.)	450–650	RBPFK-S	105605	5.7
	Medium Frame Kit* (1 ea.)	750–1200	RBPFK-M	105606	6.5
	Large Frame Kit* (1ea.)	1350–1600	RBPFK-L	105607	8.8
	Extra Large Frame Kit* (1 ea.)	1800–2400	RBPFK-XL	105608	13.0
2	Mounting Bracket Kit* (1 ea.)		RBPMBK	105603	2.7
3	Clamp Plate	450–2400	RBPCP	73162	0.5

\* Hardware included  
Lead time: 4 weeks

## Replacement Rollers

REF	DESCRIPTION	ORDERING NUMBER	ITEM CODE	WT. KG
4	Small Steel Roller	RBPSR-S	105621	5.5
	Medium Steel Roller	RBPSR-M	105622	7.5
	Large Steel Roller	RBPSR-L	105623	10.5
	Extra Large Steel Roller	RBPSR-XL	105624	16.6
5	Roller Retainer Kit (incl. 1 retainer & hardware)*	RBPRET	105613	0.2
-	Extra Large Roller Retainer Kit*	RBPRET-XL	105614	0.3

\* Hardware included  
Positioners come standard with Steel rollers.  
Lead time: 4 weeks

Stock items (non-shaded) refer to (\*) for specific lead time, if not specified, standard lead time applies.

Non-stock items (shaded) please contact Flexco for dispatch options and lead times.



# Product Ordering Information

**PTEZ™**  
Belt Trainer

## PTEZ™ Belt Trainer

BELT WIDTH	ORDERING NUMBER	ITEM CODE	WT. KG
mm			
450	PTEZ-450	90265	54.4
600	PTEZ-600	90266	58.9
750	PTEZ-750	90267	63.5
900	PTEZ-900	90268	68
1050	PTEZ-1050	90269	72.6
1200	PTEZ-1200	90270	77.1

## HD PTEZ™ Belt Trainer

BELT WIDTH	ORDERING NUMBER	ITEM CODE	WT. KG
mm			
1050	PTEZHD-1050	90616	103.6
1200	PTEZHD-1200	90617	114.5
1350	PTEZHD-1350	90618	125.9
1400	PTEZHD-1400	90795	129.5
1500	PTEZHD-1500	90619	136.8
1600	PTEZHD-1600	90796	144.1
1800	PTEZHD-1800	90620	158.6
2000	PTEZHD-2000	90797	173.6
2100	PTEZHD-2100	90621	180.9

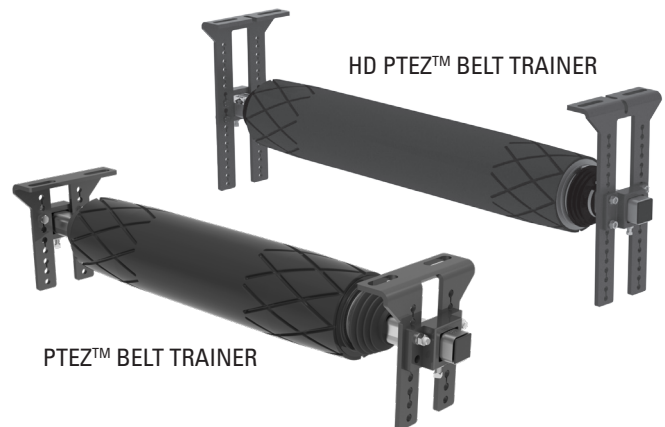

## Product Notes:

- Simple adjustable mounting brackets ensure quick and accurate installation.
- Urethane roller cover ensures long-lasting performance.
- Works in multiple applications, yet economical. Single-direction and reversing belts. Wet or dry conditions. Belts with edge damage or wear. Belts mistracking to one or both sides.
- Easy ordering and installation. Enhanced to meet instant demands for training solutions, the PTEZ is available on a one-working-day lead time. The simple brackets and component construction also ensure a quick and easy installation.
- Uses tapered and patterned roller to activate the trainer movement. Pivot influences direction while Tilt increases the tension on the mistracked side—the result is two forces quickly moving the belt back to center.
- Works with mechanically fastened or vulcanized belts.

# Replacement Parts List

## PTEZ™ Replacement Parts

REF	DESCRIPTION	ORDERING NUMBER	ITEM CODE	WT. KG
1	PTEZ HD Mount Bracket Kit (2 ea.)	PTEZHD-MBK	90803	8.6
2	PTEZ HD Pole Bracket Kit (2 ea.)	PTEZHD-PBK	90804	3.2
3	PTEZ HD Dust Cover Kit (2 ea.)	PTEZHD-DCK	90805	0.5
4	PTEZ HD Wire Rope Bolt Kit (2 ea.)	PTEZHD-WRBK	90806	0.5
5	PTEZ HD J Bolt Bracket Kit (2 ea.)	PTEZHD-JBBK	90807	0.9

\*Bracket set for 1 roller

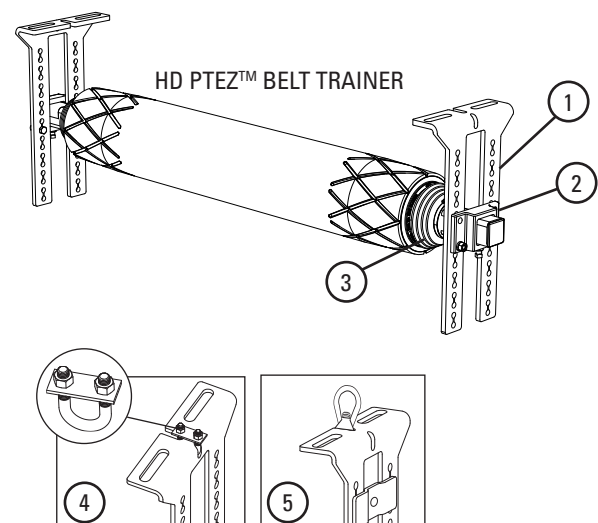

# Product Ordering Information

**PT Smart™**  
Belt Trainer

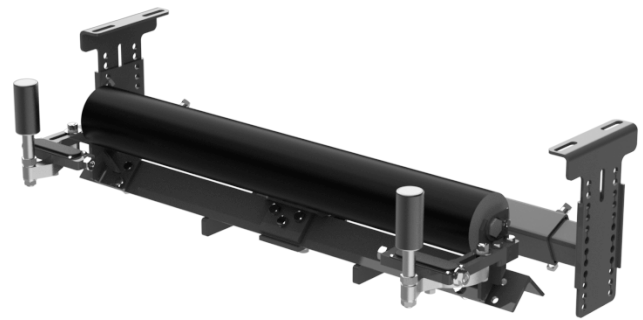

PT Smart Standard Belt Trainer  
(Roller Included)

## PT Smart™ Belt Trainer

BELT TRAINER COMPLETE			REPLACEMENT ROLLERS	
BELT WIDTH	ORDERING NUMBER	ITEM CODE	ORDERING NUMBER	ITEM CODE
mm				
450	PTS-18R	77664	PTS-RR21	77680
600	PTS-24R	77665	PTS-RR27	77681
750	PTS-30R	77666	PTS-RR33	77682
900	PTS-36R	77667	PTS-RR39	77683
1050	PTS-42R	77668	PTS-RR45	77684
1200	PTS-48R	77669	PTS-RR51	77685
1350	PTS-54R	77670	PTS-RR57	77686
1500	PTS-60R	77671	PTS-RR63	77687
1800	PTS-72R	77672	PTS-RR75	77689

Lead time: 1 week

## Selection Guidelines

CONVEYOR CRITERIA	PT SMART™
Top side mistracking	NO
Return side mistracking	YES
Belt mistracking to one side	EXCELLENT
Belt mistracking to both sides	EXCELLENT
Inconsistent tracking problem	EXCELLENT
Belt is cupped (heavy)	GOOD
Belt has low running tension	EXCELLENT
Belt has medium running tension	EXCELLENT
Belt has high running tension	GOOD
Approx. "upstream" effect*	6M
Approx. "downstream" effect*	36-45M

## Specifications:

- Maximum Belt Speed .....5 m/s
- Temperature Rating .....-40 to 71°C
- Belt Direction .....One way
- Available for Belt Widths .....450 to 1800 mm
- Application Range.....Medium-duty belts up to 1600 PIW max tension.  
Belt width + 75 mm idler.  
Belt thickness 25 mm maximum.

Stock items (non-shaded) refer to (\*) for specific lead time, if not specified, standard lead time applies.

Non-stock items (shaded) please contact Flexco for dispatch options and lead times.

# Replacement Parts List

**PT Smart™**  
Belt Trainer

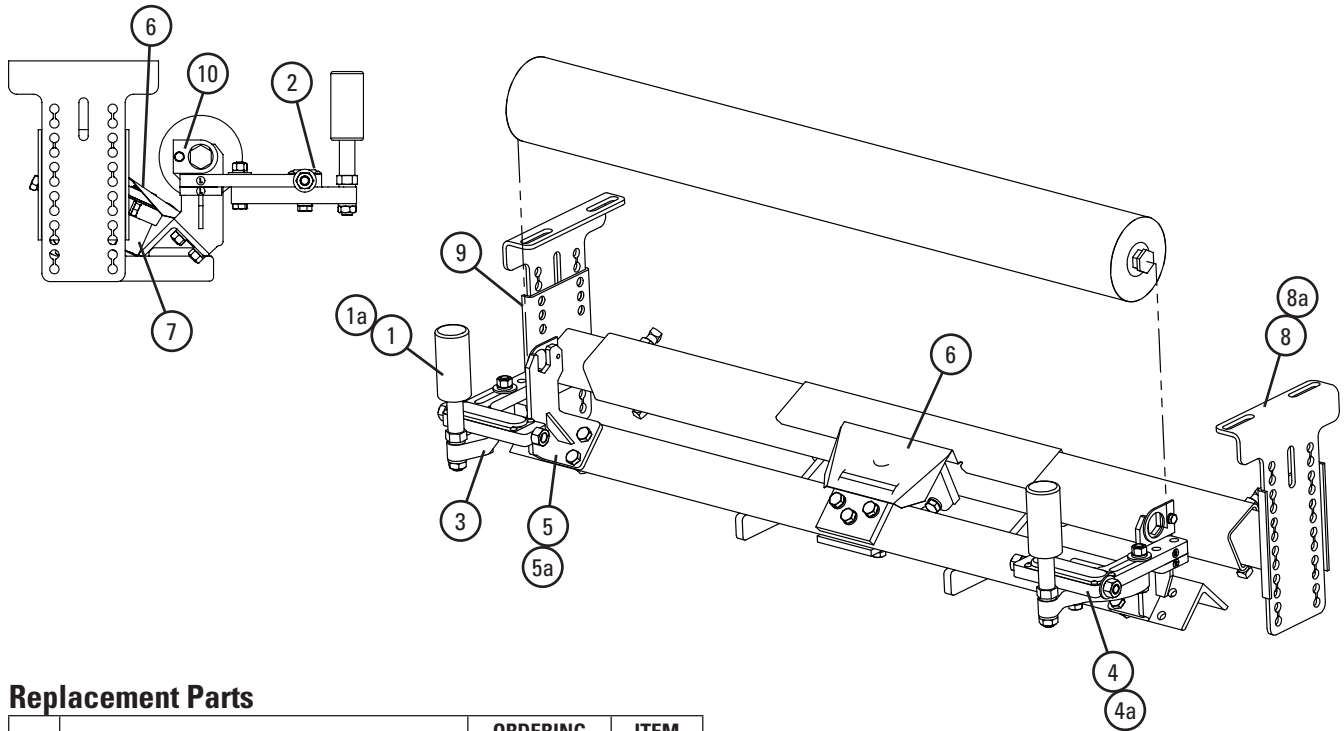

## Replacement Parts

REF	DESCRIPTION	ORDERING NUMBER	ITEM CODE
1	PTS STD Sensor Roller 50mm	PTS-SR	77691
1a	PTS HD Sensor Roller 75mm	PTS-HDSR	77692
-	Optional PTS STD Adjustable Sensor Roller 50mm	PTS-ASR	93089
-	Optional PTS STD Adjustable Sensor Roller 75mm	PTS-AHDSR	93090
2	PTS Adjusting Bolt Kit	PTS-ABK	77693
3	PTS Sensor Arm Kit (incl. 1 ea.)	PTS-SAK	77694
4	PTS RH Sensor Adjuster Assy	PTS-RHSAA	77755
4a	PTS LH Sensor Adjuster Assy	PTS-LHSAA	77756
5	PTS Idler Bracket Kit (incl. L & R)	PTS-IBK	77696
5a	PTS HD Idler Bracket Kit (incl. L & R)	PTS-HIBK	77697
6	PTS Pivot Shield	PTS-PS	77698
7	PTS Pivot Assy (Axle and housing)	PTS-PA	77699
8	PTS Mounting Bracket Kit	PTS-MBK	77700
8a	PTS Mounting Bracket Kit U/G	PTS-MBKUG	77701
9	PTS Extending Bracket Kit (incl. L & R)	PTS-EBK	77702
10	Roller Retainer Kit	RBPRET	73163

\*Hardware included

Stock items (non-shaded) refer to (\*) for specific lead time, if not specified, standard lead time applies.  
Non-stock items (shaded) please contact Flexco for dispatch options and lead times.

# Specifications & Guidelines

**PT Smart™**  
Belt Trainer

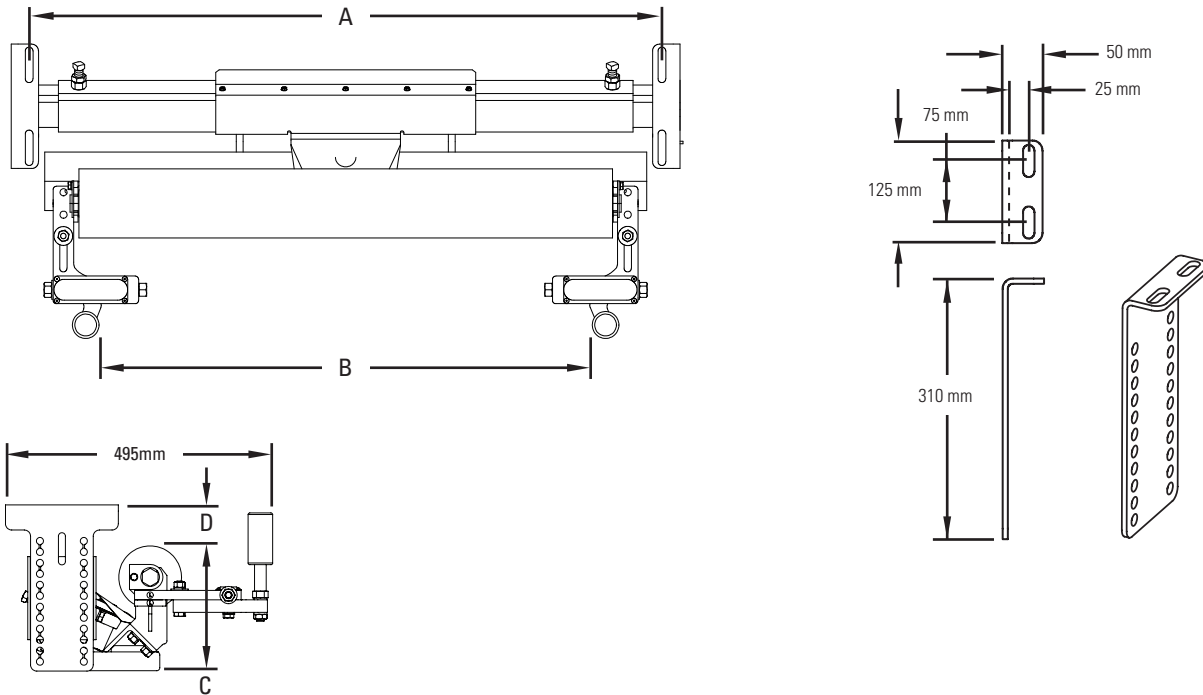

## PT Smart™ Standard

BELT WIDTH mm	ITEM CODE	A	B	C	D (vertical adjustment)
		mm	mm		mm
450	77664	575-875	250-575	250	0-250
600	77665	725-1025	400-725		
750	77666	875-1175	550-875		
900	77667	1025-1325	700-1025		
1050	77668	1175-1475	825-1175		
1200	77669	1325-1625	1000-1325		
1350	77670	1475-1775	1150-1475		
1500	77671	1625-1925	1300-1625		
1800	77672	1925-2225	1600-1925		

# Product Ordering Information

## PT Max™ Belt Trainer - Mild Steel

Please note that freight for all PT Max™ are ex-works.

### PT Max™ Top Side

	BELT WIDTH	ORDERING NUMBER	WT. KG
	mm		
SD	750	PTM-750-3	130.0
	900	PTM-900-3	140.0
	1050	PTM-1050-3	147.0
	1200	PTM-1200-3	155.0
	1350	PTM-1350-3	161.0
	1500	PTM-1500-3	164.0
HD	1600	PTM-1600-3	168.0
	1800	PTM-1800-3	186.0
	2000	PTM-2000-3	204.0
	2400	PTM-2400-3	240.0
	2600	PTM-2600-3	258.0
	3000	PTM-3000-3	294.0

Finish: Steel parts are sandblasted, primed, and powder coated.



PT MAX™ TOP SIDE BELT TRAINER:  
The PT MAX™ is delivered without rollers, but is manufactured to accommodate on site rollers. Includes Servo Rollers.



PT MAX™ RETURN SIDE BELT TRAINER  
Rollers supplied by end user.

### PT Max™ Return Side

	BELT WIDTH	ORDERING NUMBER	WT. KG
	mm		
SD	750	PTM-750-1	130.0
	900	PTM-900-1	140.0
	1050	PTM-1050-1	147.0
	1200	PTM-1200-1	155.0
	1350	PTM-1350-1	161.0
	1500	PTM-1500-1	164.0
HD	1600	PTM-1600-1	168.0
	1800	PTM-1800-1	186.0
	2000	PTM-2000-1	204.0
	2400	PTM-2400-1	240.0
	2600	PTM-2600-1	258.0
	3000	PTM-3000-1	294.0

Finish: Steel parts are sandblasted, primed, and powder coated.

### PT Max™ V-Return

	BELT WIDTH	ORDERING NUMBER	WT. KG
	mm		
SD	750	PTM-750-2	130.0
	900	PTM-900-2	140.0
	1050	PTM-1050-2	147.0
	1200	PTM-1200-2	155.0
	1350	PTM-1350-2	161.0
	1500	PTM-1500-2	164.0
HD	1600	PTM-1600-2	168.0
	1800	PTM-1800-2	186.0
	2000	PTM-2000-2	204.0
	2400	PTM-2400-2	240.0
	2600	PTM-2600-2	258.0
	3000	PTM-3000-2	294.0

Finish: Steel parts are sandblasted, primed, and powder coated.

### Replacement Servo Rollers

DESCRIPTION	ORDERING NUMBER	ITEM CODE	WT. KG
PTM Sensor Roller* (3" solid roller) (1ea.) S/S	MSR	74914	3.0



PT MAX™ V-RETURN BELT TRAINER

### Product Notes:

- Please note PT Max™ no longer utilises generic item codes. Each PT Max™ is specifically engineered and is allocated a unique 6 digit item code upon manufacture which is also the serial number.
- FPT Max™ is custom manufactured to suit your requirements. Manufacture cannot commence without a data sheet; contact Flexco for specification order sheet.
- For larger sizes please contact Flexco (Aust) Pty Ltd.
- Also available in other roller configurations—please contact Flexco.
- PT Max™ lead time is 6 weeks ex-Sydney from the receipt of an order and all data requirements. Please allow an additional two weeks for stainless steel and galvanised trackers.

# Product Ordering Information

## PT Max™ Belt Trainer - Stainless Steel

Please note that freight for all PT Max™ are ex-works.

### PT Max™ Top Side

	BELT WIDTH	ORDERING NUMBER	WT. KG
	mm		
SD	750	PTM-750-3-S/S	130.0
	900	PTM-900-3-S/S	140.0
	1050	PTM-1050-3-S/S	147.0
	1200	PTM-1200-3-S/S	155.0
	1350	PTM-1350-3-S/S	161.0
	1500	PTM-1500-3-S/S	165.0
HD	1600	PTM-1600-3-S/S	168.0
	1800	PTM-1800-3-S/S	186.0
	2000	PTM-2000-3-S/S	204.0
	2400	PTM-2400-3-S/S	240.0
	2600	PTM-2600-3-S/S	258.0
	3000	PTM-3000-3-S/S	294.0

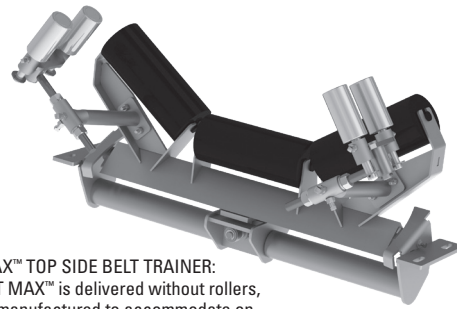

PT MAX™ TOP SIDE BELT TRAINER:  
The PT MAX™ is delivered without rollers, but is manufactured to accommodate on site rollers. Includes Servo Rollers.

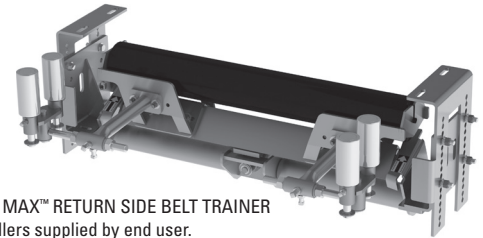

PT MAX™ RETURN SIDE BELT TRAINER  
Rollers supplied by end user.

### PT Max™ Return Side

	BELT WIDTH	ORDERING NUMBER	WT. KG
	mm		
SD	750	PTM-750-1-S/S	130.0
	900	PTM-900-1-S/S	140.0
	1050	PTM-1050-1-S/S	147.0
	1200	PTM-1200-1-S/S	155.0
	1350	PTM-1350-1-S/S	161.0
	1500	PTM-1500-1-S/S	165.0
HD	1600	PTM-1600-1-S/S	168.0
	1800	PTM-1800-1-S/S	186.0
	2000	PTM-2000-1-S/S	204.0
	2400	PTM-2400-1-S/S	240.0
	2600	PTM-2600-1-S/S	258.0
	3000	PTM-3000-1-S/S	294.0

### PT Max™ V-Return

	BELT WIDTH	ORDERING NUMBER	WT. KG
	mm		
SD	750	PTM-750-2-S/S	130.0
	900	PTM-900-2-S/S	140.0
	1050	PTM-1050-2-S/S	147.0
	1200	PTM-1200-2-S/S	155.0
	1350	PTM-1350-2-S/S	161.0
	1500	PTM-1500-2-S/S	165.0
HD	1600	PTM-1600-2-S/S	168.0
	1800	PTM-1800-2-S/S	186.0
	2000	PTM-2000-2-S/S	204.0
	2400	PTM-2400-2-S/S	240.0
	2600	PTM-2600-2-S/S	258.0
	3000	PTM-3000-2-S/S	294.0

### Replacement Servo Rollers

DESCRIPTION	ORDERING NUMBER	ITEM CODE	WT. KG
PTM Sensor Roller* (3" solid roller) (1ea.)	MSR2-S/S	79378	3.0

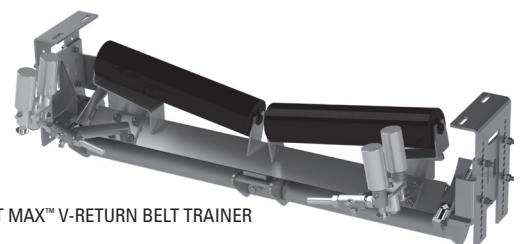

PT MAX™ V-RETURN BELT TRAINER

### Product Notes:

- Please note PT Max™ no longer utilises generic item codes. Each PT Max™ is specifically engineered and is allocated a unique 6 digit item code upon manufacture which is also the serial number.
- PT Max™ is custom manufactured to suit your requirements. Manufacture cannot commence without a data sheet; contact Flexco for specification order sheet.
- Stainless Steel PT Max™ is made from 304 Stainless Steel as standard, please specify specific requirements in the data sheet.
- For larger sizes please contact Flexco (Aust) Pty Ltd.
- Please note that PT Max™ freight terms are ex-works Sydney.
- Also available in other roller configurations—please contact Flexco.

# Replacement Parts List

**PT Max™**  
**Belt Trainer**

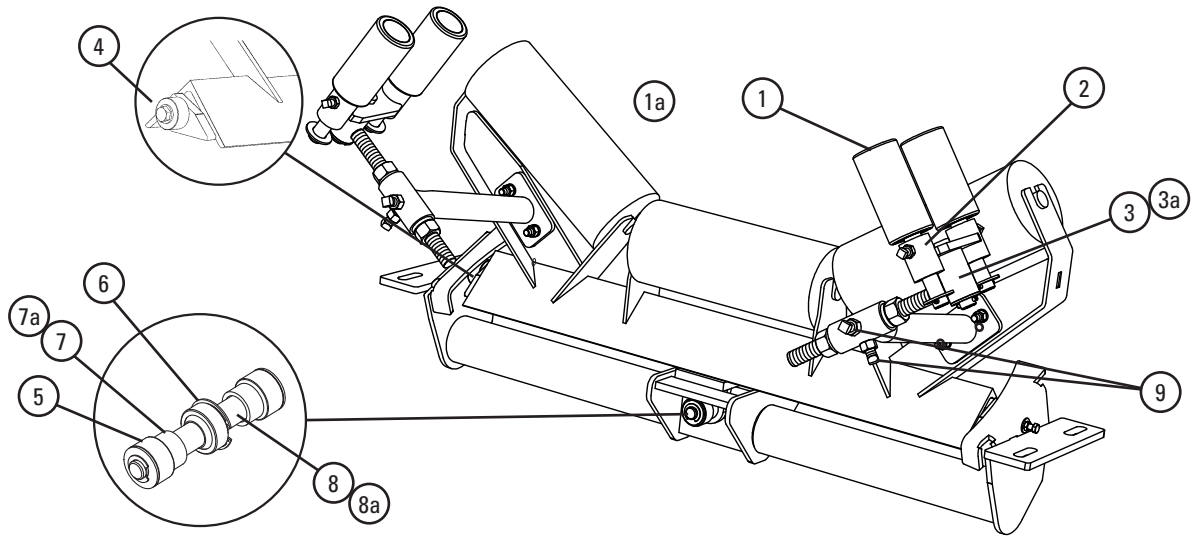

## Replacement Parts

REF	DESCRIPTION	BELT WIDTH mm	MILD STEEL		STAINLESS STEEL	
			ORDERING NUMBER	ITEM CODE	ORDERING NUMBER	ITEM CODE
1	PTM Sensor Roller* (3" solid roller) (1 ea.) - 20mm shaft	750-2100	MSR	74914		
1a	PTM Sensor Roller* (3" solid roller) (1 ea.) - 25mm shaft	750-2100	MSR2	79378		
2	Swivel Mount Kit*	750-2100	PMSMK	74916	PMSMK-S/S	64925
3	Adjusting Arm Kit*	750-1500	MAK	74918	MAK-S/S	64926
3a	HD Adjusting Arm Kit*	1350-2100	MAKHD	74919	MAKHD	74919
4	Outer Roller Kit* (incl. 2 rollers, roller thimbles and bolts, nuts and washers)	750-2100	MORK	74921	MORK	74921
5	Center Roller Kit* (incl. 2 rollers, 2 washers, and 2 cotter pins)	750-2100	MCRK	74923	MCRK	74923
6	Center Bearing*	750-2100	MCB	74925	MCB	74925
7	Center Shaft Spacer Kit (incl. 2 spacers)	750-1500	MCSK	74927	MCSK	74927
7a	HD Center Shaft Spacer Kit (incl. 2 spacers)	1350-2100	MCSKHD	74928	MCSKHD	74928
8	Center Shaft	750-1500	MCS	74930	MCS	74930
8a	HD Center Shaft	1350-2100	MCSHD	74931	MCSHD	74931
9	Frame Arm Set Screw Kit (incl. 2 setscrews and 2 jam nuts)	750-3000	MFASK	75531	MFASK	75531
-	Center Bearing Kit (incl. 1 ea. items 5, 6, 7, 8)	750-1500	MCBK	76025	MCBK	76025
-	HD Center Bearing Kit (incl. 1 ea. items 5, 6, 7a, 8a)	1350-2100	MCBKHD	76026	MCBKHD	76026

Lead time: 3 weeks

Stock items (non-shaded) refer to (\*) for specific lead time, if not specified, standard lead time applies.  
Non-stock items (shaded) please contact Flexco for dispatch options and lead times.



# Product Ordering Information

## PT Max™ Adjustable Belt Trainer

### PT Max™ Adjustable Top Side

VERSION	BELT WIDTH	ORDERING NUMBER	ITEM CODE	WT. KGS.
	mm			
Standard	750	PTMA-750-3	83785	161.0
	900	PTMA-900-3	83661	170.0
	1050	PTMA-1050-3	83662	184.0
	1200	PTMA-1200-3	83663	193.0
	1350	PTMA-1350-3	83664	202.0
	1600	PTMA-1600-3	83665	229.0
Heavy-Duty	1800	PTMAHD-1800-3	83734	277.0
	2000	PTMAHD-2000-3	83735	290.0
	2200	PTMAHD-2400-3	83736	304.0



PT MAX™ ADJUSTABLE TOP SIDE BELT TRAINER

### PT Max Adjustable Return Side

VERSION	BELT WIDTH	ORDERING NUMBER	ITEM CODE	WT. KGS.
	mm			
Standard	750	PTMA-750-1	83786	154.0
	900	PTMA-900-1	83667	170.0
	1050	PTMA-1050-1	83668	179.0
	1200	PTMA-1200-1	83669	188.0
	1350	PTMA-1350-1	83670	195.0
	1600	PTMA-1600-1	83671	236.0
	1800	PTMA-1800-1	83672	245.0
Heavy-Duty	1800	PTMAHD-1800-1	83737	279.0
	2000	PTMAHD-2000-1	83738	290.0
	2200	PTMAHD-2400-1	83739	302.0



PT MAX™ ADJUSTABLE RETURN SIDE BELT TRAINER

### PT Max Adjustable V-Return

VERSION	BELT WIDTH	ORDERING NUMBER	ITEM CODE	WT. KGS.
	mm			
Standard	900	PTMA-750-2	83673	195.0
	1050	PTMA-1050-2	83674	204.0
	1200	PTMA-1200-2	83675	215.0
	1350	PTMA-1350-2	83676	225.0
	1600	PTMA-1600-2	83677	236.0
	1800	PTMA-1800-2	83678	277.0
Heavy-Duty	1800	PTMAHD-1800-2	83740	288.0
	2000	PTMAHD-2000-2	83741	329.0
	2200	PTMAHD-2400-2	83742	349.0

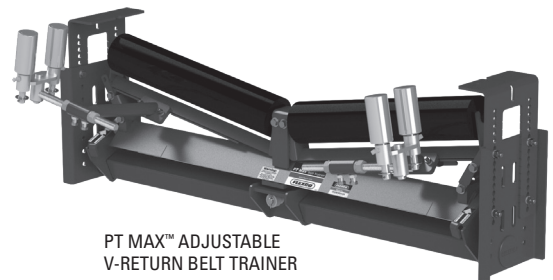

PT MAX™ ADJUSTABLE V-RETURN BELT TRAINER

Please contact Flexco for availability and lead times.

### Product Notes:

- PT Max™ Adjustable takes the best features from the PT Max™ and integrates the adaptability of the PT Smart™ to create a fully-adjustable design that can fit almost any conveyor configuration without needing a data sheet.
- Standardised parts allow us to manage costs, include the rollers, and reduce lead times – down to 1 day on core sizes.
- Works in multiple applications. Top side or return side belts. Heavy duty or medium duty operations. Wet or dry conditions. Belts mistracking to one side or both sides. Whatever the issue, PT Max™ Adjustable has the answer.

**Stock items** (non-shaded) refer to (\*) for specific lead time, if not specified, standard lead time applies.
   
 **Non-stock items** (shaded) please contact Flexco for dispatch options and lead times.

# Replacement Parts List

**PT Max™**  
Adjustable Belt Trainer

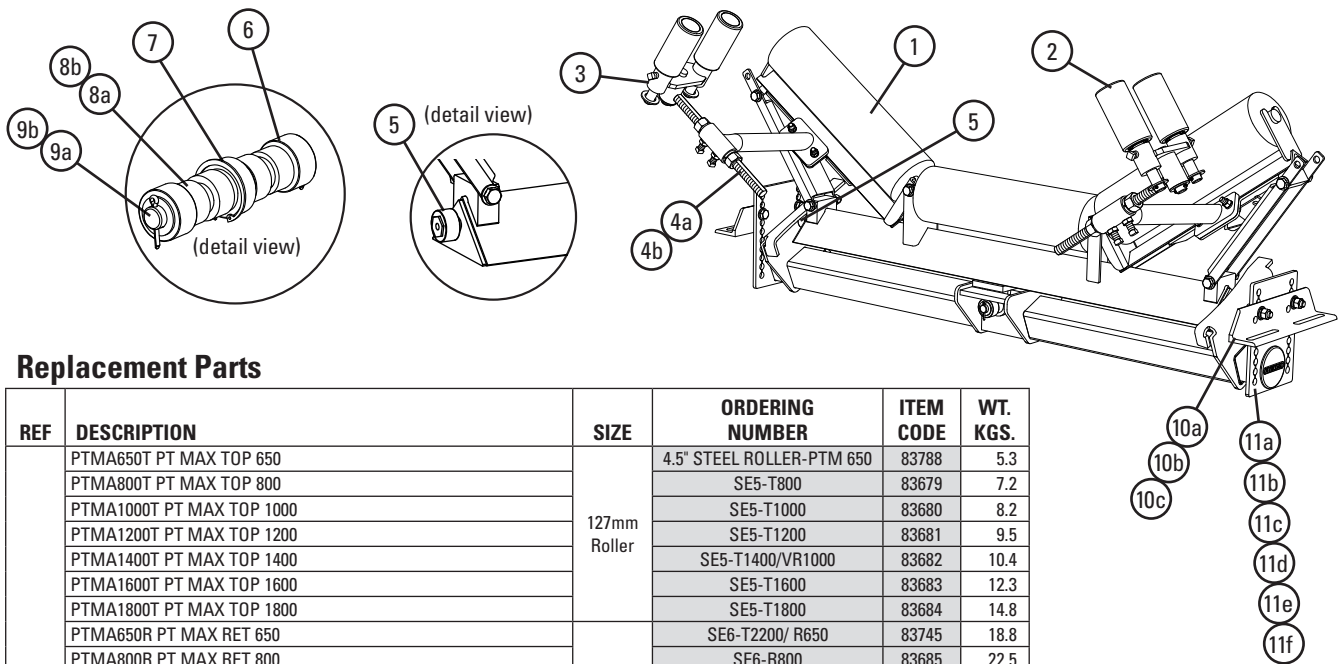

## Replacement Parts

REF	DESCRIPTION	SIZE	ORDERING NUMBER	ITEM CODE	WT. KGS.	
1	PTMA650T PT MAX TOP 650	127mm Roller	4.5" STEEL ROLLER-PTM 650	83788	5.3	
	PTMA800T PT MAX TOP 800		SE5-T800	83679	7.2	
	PTMA1000T PT MAX TOP 1000		SE5-T1000	83680	8.2	
	PTMA1200T PT MAX TOP 1200		SE5-T1200	83681	9.5	
	PTMA1400T PT MAX TOP 1400		SE5-T1400/VR1000	83682	10.4	
	PTMA1600T PT MAX TOP 1600		SE5-T1600	83683	12.3	
	PTMA1800T PT MAX TOP 1800		SE5-T1800	83684	14.8	
	PTMA650R PT MAX RET 650	152.4mm Roller	SE6-T2200/ R650	83745	18.8	
	PTMA800R PT MAX RET 800		SE6-R800	83685	22.5	
	PTMA1000R PT MAX RET 1000		SE6-R1000	83686	25.6	
	PTMA1200R PT MAX RET 1200		SE6-R1200	83687	30.9	
	PTMA1400R PT MAX RET 1400		SE6-R1400	83688	35.2	
	PTMA1600R PT MAX RET 1600		SE6-R1600	83689	40.2	
	PTMA1800R PT MAX RET 1800		SE6-R1800	83690	46.5	
	PT MAX V RETURN 800	127mm Roller	SE5-VR800	83691	8.5	
	PT MAX V RETURN 1000		SE5-T1400 /VR1000	83682	10.5	
	PT MAX V RETURN 1200		SE5-VR1200	83692	11.3	
	PT MAX V RETURN 1400		SE5-VR1400	83693	12.5	
	PT MAX V RETURN 1600		SE5-VR1600	83694	14.2	
	PT MAX V RETURN 1800		SE5-VR1800	83695	16.2	
	PTMAHD1800T PT MAX TOP 1800	152.4mm Roller	SE6-T1800	83743	15.3	
	PTMAHD2000T PT MAX TOP 2000		SE6-T2000	83744	17.1	
	PTMAHD2200T PT MAX TOP 2200		SE6-T2200/ R650	83745	18.8	
	PTMAHD1800R PT MAX RET 1800		SE6-R1800	83690	46.5	
	PTMAHD2000R PT MAX RET 2000		SE6-R2000	83746	53.5	
	PTMAHD2200R PT MAX RET 2200		SE6-R2200	83747	57.3	
	PTMAHD1800VR PT MAX V-RET 1800		SE6-VR1800	83748	27.2	
	PTMAHD2000VR PT MAX V-RET 2000		SE6-VR2000	83749	30.3	
	PTMAHD2200VR PT MAX V-RET 2200		SE6-VR2200	83750	35.5	
	2		Sensor Roller 2.0* (3" solid roller)(1 ea.) (Top, Flat, V Return)		MSR	74914
	3	Swivel Mount Kit 2.0* (Top, Flat, V Return)		PMSMK2	79380	2.5
	4a	PTMA Adjusting Arm Kit (Top, Flat, V Return)		PTMAAK	90194	2.7
4b	PTMA Adjusting Arm Kit HD (Top, Flat, V Return HD)		PTMAAKHD	90195	4.1	
5	Outer Roller Kit (Top, Flat, V Return) (incl. 2 rollers, roller thimbles, and bolts, nuts, & washers)		PTMAORK	90197	0.5	
6	Center Roller Kit (Top, Flat, V Return) (incl. 2 rollers, 2 washers, & 2 cotter pins)		MCRK	74923	0.5	
7	Center Bearing (Top, Flat, V Return)		MCB	74925	0.8	
8a	Center Shaft Spacer Kit (incl. 2 spacers) (Top, Flat, V Return)		MCSK	74927	0.1	
8b	Center Shaft Spacer Kit HD (incl. 2 spacers) (Top, Flat, V Return HD)		MCSKHD	74928	0.2	
9a	Center Shaft (Top, Flat, V Return)		MCS	74930	1.8	
9b	Center Shaft HD (Top, Flat, V Return HD)		MCSHD	74931	5.9	
10a	Frame Mount Kit (Top)		PTMAFMKT	90185	6.6	
10b	Frame Mount Kit (Flat/V Return)		PTMAFMKR	90186	19.1	
10c	Frame Mount Kit (Flat/V Return HD)		PTMAFMKHDR	90187	22.4	
11a	Extender Kit (Top)		PTMAEKT	90188	15.4	
11b	Extender Kit (Top HD)		PTMAEKHDT	90191	22.6	
11c	Extender Kit (Flat Return)		PTMAEKR	90189	25.9	
11d	Extender Kit (Flat Return HD)		PTMAEKHDR	90192	39.2	
11e	Extender Kit (V Return)		PTMAEKVR	90190	34.5	
11f	Extender Kit (V Return HD)		PTMAEKHVR	90193	50.9	
-	Center Bearing Kit (incl. 1 ea. Items 6, 7, 8a, 9a) (Top, Flat, V Return)		MCBK	76025	3.6	
-	Center Bearing Kit HD (incl. 1 ea. Items 6, 7, 8b, 9b) (Top, Flat, V Return HD)		MCBKHD	76026	7.7	

\*Hardware included

Please contact Flexco for availability and lead times.

# Product Ordering Information

**Flex-Lok™ Skirt Clamps**

## Flex-Lok™ Skirt Clamp-Mild Steel

- One Standard Skirt Clamp includes one 2 M mounting channel, 4 clamp plates, 4 clamp pins and one 2 M restraining bar.
- One Mini Skirt Clamp includes one 2 M mounting channel, 3 clamp plates, 3 clamp pins and one 2 M restraining bar.
- Skirt board and rubber not included.

DESCRIPTION	ORDERING NUMBER	ITEM CODE	WT. KG
Flex-Lok™ Skirt Clamp Complete	FLSC2000	71053	18.0
Mini Flex-Lok™ Skirt Clamp Complete	FLSCM2000	71148	15.0
REPLACEMENT PARTS			
Toggle Pin	FLSC-TP	71056	1.0
Clamp Plate	FLSC-CP	71057	1.0
Mini Clamp Plate	FLSCM-CP	71140	1.0
Clamp Bar-2000mm	FLSC2000-CB	71061	5.0
Mounting Channel-2000mm	FLSC2000-MC	71059	3.0

Finish: Clamp plates and clamp bars are powder coated steel. Mounting channel is powder coated. Toggle pins are zinc passivated steel. Skirt rubber not included.

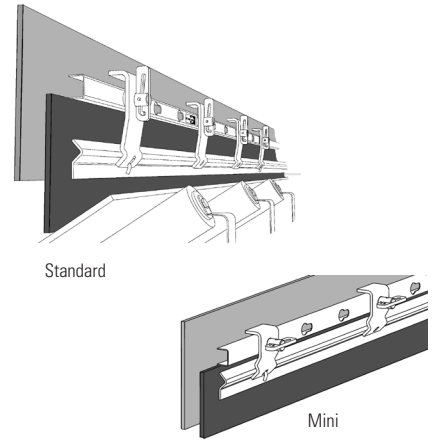

## Flex-Lok™ Skirt Clamp-Stainless Steel

- One Standard Skirt Clamp includes one 2 M mounting channel, 4 clamp plates, 4 clamp pins and one 2 M restraining bar.
- One Mini Skirt Clamp includes one 2 M mounting channel, 3 clamp plates, 3 clamp pins and one 2 M restraining bar.
- Skirt board and rubber not included.

DESCRIPTION	ORDERING NUMBER	ITEM CODE	WT. KG
Flex-Lok™ Skirt Clamp Complete	FLSC2000-S/S	A1436	20.0
Mini Flex-Lok™ Skirt Clamp Complete	FLSCM2000-S/S	61471	15.0
REPLACEMENT PARTS			
Toggle Pin	FLSC-TP-S/S	A1437	1.0
Clamp Plate	FLSC-CP-S/S	A1438	1.0
Mini Clamp Plate	FLSCM-CP-S/S	A2596	1.0
Clamp Bar-2000mm	FLSC2000-CB-S/S	A1439	5.0
Mounting Channel-2000mm	FLSC2000-MC-S/S	A1440	3.0

All components supplied in 300 Series Stainless.

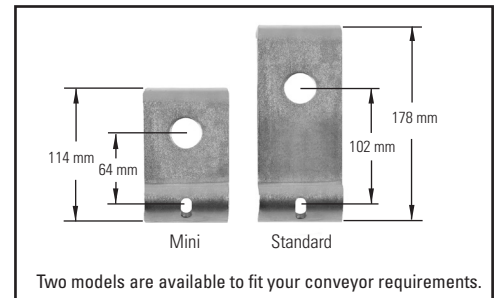

## Flex-Lok™ Specifications

SKIRT RUBBER THICKNESS RANGE	
Thickness Range	8–25mm

## Product Notes:

- Solves material spillage problems in the conveyor loading zone.
- Stops material loss, eliminates safety hazards, and reduces wear on conveyor components.

**Stock items** (non-shaded) refer to (\*) for specific lead time, if not specified, standard lead time applies.
   
 **Non-stock items** (shaded) please contact Flexco for dispatch options and lead times.

# Product Ordering Information

**Flex-Seal™ Skirt System**

## Flex-Seal™ Skirt System

DESCRIPTION	ORDERING NUMBER	ITEM CODE	WT. KG
Flex-Seal™ Skirt System*	RMC-FS	76558	13.4
<b>REPLACEMENT PARTS**</b>			
Angle Plate	RMC2-FSAPK	76559	8.6
Angle Plate Stainless Steel	RMC2-AP-S/S	A2704	8.6
PAL PAK	RMC1-PP	75832	3.0
Bolt-On PAL PAK	RMC1-BPP	76415	3.0
Clamp Bar	RMC1-CB	75820	1.8

\*Flex-Seal Skirt System includes angle plate, one Bolt-On PAL PAK, and one 1.2 M clamp bar. Skirt board and rubber not included. Skirt rubber thickness range: 8–19 mm.

\*\*Replacement parts include two Bolt-On clamp pins and two clamp plates.

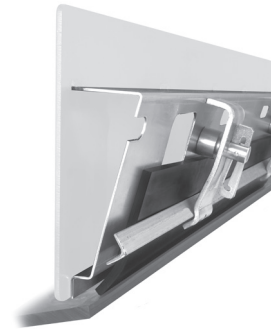

Bolt-On PAL PAK

## Flex-Seal™ Specifications

SKIRT RUBBER THICKNESS RANGE	
Width Required	150mm
Thickness Range	8–19mm

# Product Ordering Information

**Dual Seal Polyurethane Skirting**

## Dual Seal Polyurethane Skirting

Height	Thickness	Length	CHAMFER	ORDERING NUMBER	ITEM CODE	WT. KG
mm	mm	m				
150	12	7.6	35°	SKPU-DUAL-150x12x7.6	91400	21.3
150	20			SKPU-DUAL-150x20x7.6	91401	30.8
200	12			SKPU-DUAL-200x12x7.6	91402	27.4
200	20			SKPU-DUAL-200x20x7.6	91403	40.0
150	12	15.2		SKPU-DUAL-150x12x15.2	91404	42.6
150	20			SKPU-DUAL-150x20x15.2	91405	61.5
200	12			SKPU-DUAL-200x12x15.2	91406	54.9
200	20			SKPU-DUAL-200x20x15.2	91407	79.9

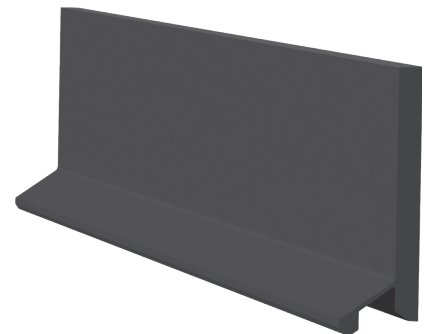

## Product Notes:

- Secondary seal provides a floating contact area behind the main slab to prevent spillage.
- Polyurethane skirting offers a more wear-resistant material than typical rubber, often providing as much as 3-4 times the wear life in similar applications.  
The lower coefficient of friction reduces strain on the system.
- Works with Flexco series of skirt clamps that offer simple serviceability: RMC1/PAL-Pak, Flex-Lok™, and Flex-Seal™.
- Uses soft durometer (65A) polyurethane with exceptional tear resistance to ensure a good seal and long belt life.
- 7.6 m roll size ensures easy transportation, while the 35° chamfer eliminates the typical skirting break-in period.
- Suitable for most applications: single direction or reversing belts, wet or dry conditions, old or new belts, vulcanized or mechanically-spliced systems.
- Rated for temperatures from -30 to 82°C.

 **Stock items** (non-shaded) refer to (\*) for specific lead time, if not specified, standard lead time applies.

 **Non-stock items** (shaded) please contact Flexco for dispatch options and lead times.

# Product Ordering Information

## Standard Urethane Skirting

### Standard Urethane Skirting with 35° Chamfer\* - 7.6 M

Height	Thickness	Length	ORDERING NUMBER	ITEM CODE	WT. KG
mm	mm	m			
100	10	7.6	SKPU-100x10x7.6	91288	9.61
100	12	7.6	SKPU-100x12x7.6	91289	12.79
100	16	7.6	SKPU-100x16x7.6	91290	16.01
100	19	7.6	SKPU-100x19x7.6	91291	19.19
100	25	7.6	SKPU-100x25x7.6	91292	25.58
150	10	7.6	SKPU-150x10x7.6	91298	14.38
150	12	7.6	SKPU-150x12x7.6	90283	8.2
150	16	7.6	SKPU-150x16x7.6	91299	24.00
150	20	7.6	SKPU-150x20x7.6	90284	12.38
150	25	7.6	SKPU-150x25x7.6	91300	38.37
200	10	7.6	SKPU-200x10x7.6	91304	19.19
200	12	7.6	SKPU-200x12x7.6	90285	11.97
200	16	7.6	SKPU-200x16x7.6	91305	31.98
200	20	7.6	SKPU-200x20x7.6	90286	18.14
200	25	7.6	SKPU-200x25x7.6	91306	51.17
250	10	7.6	SKPU-250x10x7.6	91310	23.99
250	12	7.6	SKPU-250x12x7.6	91311	31.98
250	16	7.6	SKPU-250x16x7.6	91312	39.96
250	19	7.6	SKPU-250x19x7.6	91313	47.99
250	25	7.6	SKPU-250x25x7.6	91314	63.96
300	10	7.6	SKPU-300x10x7.6	91320	28.80
300	12	7.6	SKPU-300x12x7.6	91321	38.37
300	16	7.6	SKPU-300x16x7.6	91322	47.99
300	19	7.6	SKPU-300x19x7.6	91323	57.56
300	25	7.6	SKPU-300x25x7.6	91234	76.75



### Standard Urethane Skirting with 35° Chamfer\* - 15.2 M

Height	Thickness	Length	ORDERING NUMBER	ITEM CODE	WT. KG
mm	mm	m			
100	10	15.2	SKPU-100x10x15.2	91293	19.19
100	12	15.2	SKPU-100x12x15.2	91294	25.58
100	16	15.2	SKPU-100x16x15.2	91295	31.98
100	19	15.2	SKPU-100x19x15.2	91296	38.37
100	25	15.2	SKPU-100x25x15.2	91297	51.17
150	10	15.2	SKPU-150x10x15.2	91301	28.80
150	12	15.2	SKPU-150x12x15.2	91222	38.37
150	16	15.2	SKPU-150x16x15.2	91302	47.99
150	19	15.2	SKPU-150x19x15.2	91223	57.56
150	25	15.2	SKPU-150x25x15.2	91303	76.75
200	10	15.2	SKPU-200x10x15.2	91307	38.37
200	12	15.2	SKPU-200x12x15.2	91224	51.17
200	16	15.2	SKPU-200x16x15.2	91308	63.96
200	19	15.2	SKPU-200x19x15.2	91225	76.75
200	25	15.2	SKPU-200x25x15.2	91309	102.33
250	10	15.2	SKPU-250x10x15.2	91315	47.99
250	12	15.2	SKPU-250x12x15.2	91316	63.96
250	16	15.2	SKPU-250x16x15.2	91317	79.97
250	19	15.2	SKPU-250x19x15.2	91318	95.93
250	25	15.2	SKPU-250x25x15.2	91319	127.91
300	10	15.2	SKPU-300x10x15.2	91325	57.56
300	12	15.2	SKPU-300x12x15.2	91326	76.75
300	16	15.2	SKPU-300x16x15.2	91327	95.93
300	19	15.2	SKPU-300x19x15.2	91328	115.12
300	25	15.2	SKPU-300x25x15.2	91329	153.50

### Product Notes:

- Urethane skirting offers a more wear-resistant material than typical rubber, often providing as much as 3-4 times the wear life in similar applications. The lower coefficient of friction reduces strain on the system.
- Works with Flexco series of skirt clamps that offer simple serviceability: RMC1/PAL-Pak, Flex-Lok, and Flex-Seal.
- Uses soft durometer (65A) urethane with exceptional tear resistance to ensure a good seal and long belt life.
- 7.6M roll size ensures easy transportation, while the 35° chamfer eliminates the typical skirting break-in period.
- Suitable for most applications: single direction or reversing belts, wet or dry conditions, old or new belts, vulcanised or mechanically-spliced systems.
- Rated for temperatures from -30 to 82°C.

Stock items (non-shaded) refer to (\*) for specific lead time, if not specified, standard lead time applies.

Non-stock items (shaded) please contact Flexco for dispatch options and lead times.

# Product Ordering Information

## Enclosed Skirt System

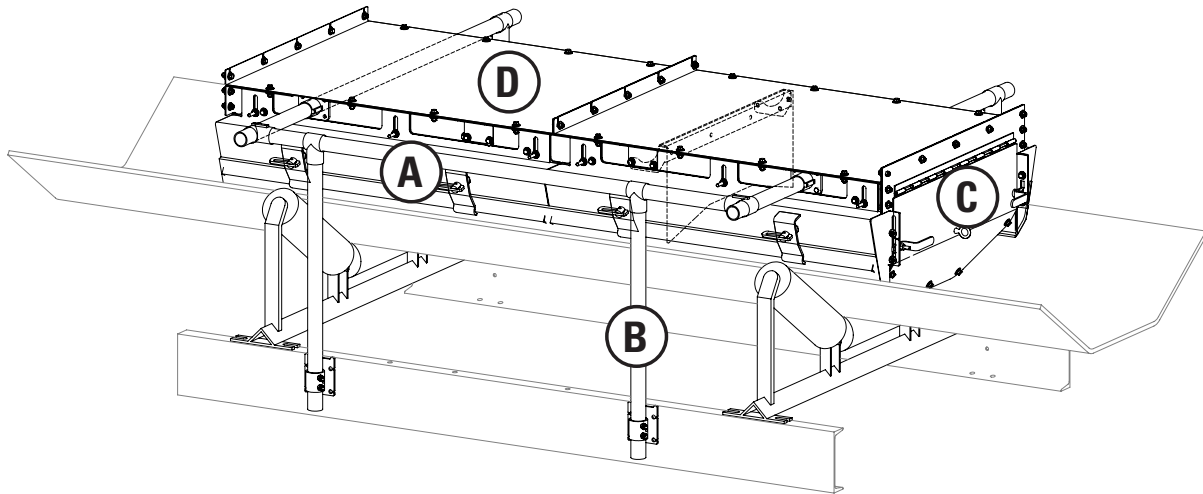

### COMPONENTS

- A. SKIRT BOARD** – required  
Available in 1200 or 2400 mm sections
- B. SUPPORT LEGS** – required  
For belt widths 600–2400 mm  
Sold as two legs with a cross bar support
- C. END PLATE** – optional  
For belt widths 600–2400 mm
- D. COVER PLATE** – optional  
Available in 1200 mm sections  
For belt widths 600–2400 mm

### PRODUCT/ORDERING NOTES

- Maximum span between support legs is 2400 mm (or 2.4 M) and they are to be attached to the conveyor stringer or truss
- Skirting solutions do not include required skirt rubber; purchase from local Flexco distribution
- Straight skirt wall and tangential skirt wall available for different skirt rubber sealing options
- Product is built and sold to CEMA standards
- Skirt board liners are made with AR400 abrasive resistant plate steel

### ORDERING EXAMPLE

For a covered 1200 mm belt skirting system to cover 2.4 M of conveyor, as shown above, with (2) 1200 skirt covers, (4) 1200 mm tangential skirt walls, (1) rear seal, and (2) support legs the following should be ordered:

- A. (2) Covers, order number: SC-7-48
- B. (4) 1200 mm Tangential Skirt Wall, order number: 4-X-15-4-T-1 or (2) 2400 mm skirt walls, use 8-X-15-4-T-1
- C. (2) Support Legs, order number: LA-48
- D. (1) Rear Seal, order number: RS-1-15-48-35

 **Stock items** (non-shaded) refer to (\*) for specific lead time, if not specified, standard lead time applies.

 **Non-stock items** (shaded) please contact Flexco for dispatch options and lead times.



# Product Ordering Information

## Enclosed Skirt System

### Skirt Walls\*

Skirting sections do not include required skirt rubber; purchase from local Flexco distribution.

WALL LENGTH	STRAIGHT SKIRT WALL	
mm	ORDERING NUMBER	WEIGHT KG
1219	4-X-15-4-S-1	29.5
2438	8-X-15-4-S-1	59.0

WALL LENGTH	TANGENTIAL SKIRT WALL	
mm	ORDERING NUMBER	WEIGHT KG
1219	4-X-15-4-T-1	41.3
2438	8-X-15-4-T-1	83.0

Tangential skirt wall option requires a properly tracked belt within CEMA recommendations.

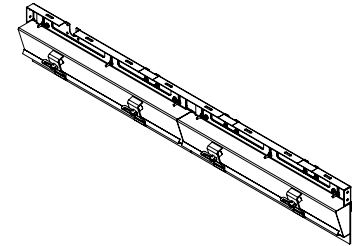
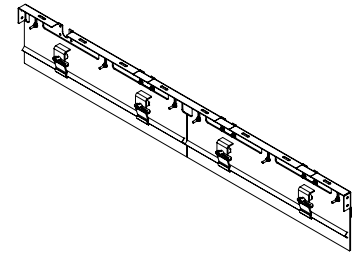

### Rear Seal\*

A rear seal can be used to enclose the rear of a skirting while providing access into the system.

BELT WIDTH	REAR SEAL	
mm	ORDERING NUMBER	WEIGHT KG
600	RS-1-15-24-35	7.7
750	RS-1-15-30-35	9.5
900	RS-1-15-36-35	11.3
1050	RS-1-15-42-35	13.6
1200	RS-1-15-48-35	15.4
1350	RS-1-15-54-35	17.7
1500	RS-1-15-60-35	20.0
1650	RS-1-15-66-35	21.8
1800	RS-1-15-72-35	24.5
2100	RS-1-15-84-35	30.0
2400	RS-1-15-96-35	35.8

Do not use a rear seal for a reversing conveyor belt.

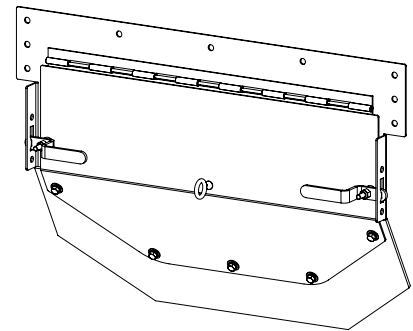

### Skirt Cover\*

BELT WIDTH	1200mm SKIRT COVER	
mm	ORDERING NUMBER	WEIGHT KG
600	SC-7-24	4.5
750	SC-7-30	5.4
900	SC-7-36	6.4
1050	SC-7-42	7.3
1200	SC-7-48	6.2
1350	SC-7-54	9.1
1500	SC-7-60	10.0
1650	SC-7-66	10.7
1800	SC-7-72	12.2
2100	SC-7-84	14.1
2400	SC-7-96	15.9

Skirt covers are made out of aluminum.

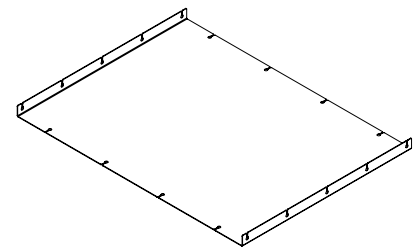

**Stock items** (non-shaded) refer to (\*) for specific lead time, if not specified, standard lead time applies.
   
 **Non-stock items** (shaded) please contact Flexco for dispatch options and lead times.



# Product Ordering Information

## Enclosed Skirt System

### Dust Curtain\*

BELT WIDTH	DUST CURTAIN (OPTIONAL)	
mm	ORDERING NUMBER	WEIGHT KG
600	DC-1-15-24-35	2.3
750	DC-1-15-30-35	2.7
900	DC-1-15-36-35	3.2
1050	DC-1-15-42-35	3.6
1200	DC-1-15-48-35	3.6
1350	DC-1-15-54-35	4.1
1500	DC-1-15-60-35	4.5
1650	DC-1-15-66-35	4.5
1800	DC-1-15-72-35	5.0
2100	DC-1-15-84-35	5.4
2400	DC-1-15-96-35	5.4

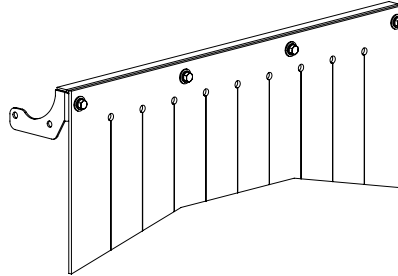

### Support Leg Assembly\*

BELT WIDTH	SUPPORT LEG ASSEMBLY	
mm	ORDERING NUMBER	WEIGHT KG
600	LA-24	14.1
750	LA-30	14.5
900	LA-36	15.4
1050	LA-42	16.3
1200	LA-48	17.2
1350	LA-54	17.7
1500	LA-60	19.1
1650	LA-66	19.5
1800	LA-72	20.0
2100	LA-84	21.8
2400	LA-96	23.6

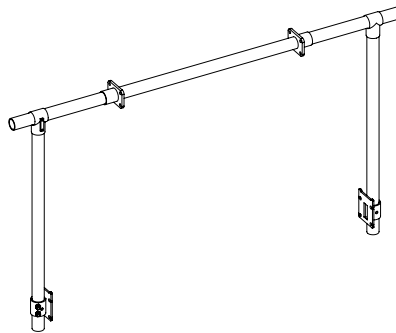

Locate a support leg at a maximum every 2400mm (or 2.4M). Skirt walls can accommodate support legs every 600mm (or 0.6M).

### Cross Brace Spanner\*

SPANNER LEG	CROSS BRACE SPANNER (OPTIONAL)	
mm	ORDERING NUMBER	WEIGHT KG
609	SP-24	2.7
1219	SP-48	5.0
1829	SP-72	7.3
2438	SP-96	10.0

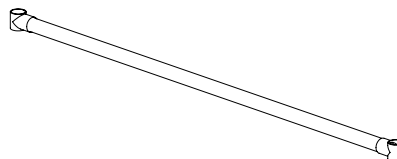

Cross brace spanner can be used to connect between cross braces to locate the vertical section of the support leg assembly anywhere along the cross brace spanner. Support legs need to be located at a maximum of every 2400mm (or 2.4M).

 **Stock items** (non-shaded) refer to (\*) for specific lead time, if not specified, standard lead time applies.

 **Non-stock items** (shaded) please contact Flexco for dispatch options and lead times.



# INDEX By Ordering Number

Ordering Number	Item Code	Page #	Ordering Number	Item Code	Page #	Ordering Number	Item Code	Page #	Ordering Number	Item Code	Page #
	67324	57	BP-LA-S/S	A0614	153	CART-36/900-S/S	78578	76	CART2-72/1800-S/S	78585	97
	67325	57	BP-MB	73123	153	CART-36/900-S/S	78578	78	CART2-72/1800-S/S	78585	99
	91090	57	BP-MB-S/S	A0615	153	CART-36/900-S/S	78578	83	CART2-78/1950-S/S	78635	42
	91091	57	BP-SC	73125	153	CART-36/900-S/S	78578	85	CART2-78/1950-S/S	78635	47
	91092	57	BP-SC-S/S	A0616	153	CART-36/900-S/S	78578	90	CART2-78/1950-S/S	78635	76
	64205	57	BP-TB	73138	153	CART-36/900-S/S	78578	92	CART2-78/1950-S/S	78635	78
	64206	57	BP-TL	73141	153	CART-36/900-S/S	78578	97	CART2-78/1950-S/S	78635	83
	64207	57	BP-TL-S/S	A0617	153	CART-36/900-S/S	78578	98	CART2-78/1950-S/S	78635	85
	64208	57	BP-UB	73139	153	CART-42/1050-S/S	78579	41	CART2-78/1950-S/S	78635	90
	64209	57	BP1050	73110	152	CART-42/1050-S/S	78579	46	CART2-78/1950-S/S	78635	92
	64211	57	BP1050-B	73780	153	CART-42/1050-S/S	78579	76	CART2-78/1950-S/S	78635	97
	GR298	57	BP1050-S/S	76342	152	CART-42/1050-S/S	78579	78	CART2-78/1950-S/S	78635	99
	B0536	57	BP1200	73112	152	CART-42/1050-S/S	78579	83	CART2-84/2100-S/S	78586	42
	67586	130	BP1200-1400-PL	73118	153	CART-42/1050-S/S	78579	85	CART2-84/2100-S/S	78586	47
	67587	130	BP1200-1400-PL-S/S	A0621	153	CART-42/1050-S/S	78579	90	CART2-84/2100-S/S	78586	76
	68844	130	BP1200-1400MF	73154	153	CART-42/1050-S/S	78579	92	CART2-84/2100-S/S	78586	78
	67268	130	BP1200-1400MF-S/S MAIN FRAME	A0620	153	CART-42/1050-S/S	78579	97	CART2-84/2100-S/S	78586	83
	67267	130	BP1200-B	73781	153	CART-42/1050-S/S	78579	98	CART2-84/2100-S/S	78586	85
	67437	130	BP1200-S/S	76343	152	CART-48/1200-S/S	78580	76	CART2-84/2100-S/S	78586	90
	62445	130	BP1400	73113	152	CART-48/1200-S/S	78580	78	CART2-84/2100-S/S	78586	92
	62446	130	BP1400-B	73782	153	CART-48/1200-S/S	78580	83	CART2-84/2100-S/S	78586	97
	62447	130	BP1400-S/S	76344	152	CART-48/1200-S/S	78580	85	CART2-84/2100-S/S	78586	99
	62448	130	BP1500	73114	152	CART-48/1200-S/S	78580	90	CART2-96/2400-S/S	78587	42
4.5" STEEL ROLLER - PTM 650	83788	172	BP1500-1600-PL	73119	153	CART-48/1200-S/S	78580	92	CART2-96/2400-S/S	78587	47
ABU	76788	104	BP1500-1600-PL-S/S	A0647	153	CART-48/1200-S/S	78580	97	CART2-96/2400-S/S	78587	76
ABU	76788	104	BP1500-1600MF	73147	153	CART-48/1200-S/S	78580	98	CART2-96/2400-S/S	78587	78
ABU	76788	105	BP1500-1600MF-S/S MAIN FRAME	A0646	153	CART-54/1350-S/S	78581	76	CART2-96/2400-S/S	78587	83
ABU	76788	105	BP1500-B	73783	153	CART-54/1350-S/S	78581	78	CART2-96/2400-S/S	78587	85
ACME-N	62591	35	BP1500-S/S	76345	152	CART-54/1350-S/S	78581	83	CART2-96/2400-S/S	78587	90
ACME-N	62591	35	BP1600	73115	152	CART-54/1350-S/S	78581	85	CART2-96/2400-S/S	78587	92
ACME-N	62591	35	BP1600-B	73784	153	CART-54/1350-S/S	78581	90	CART2-96/2400-S/S	78587	97
ACME-N	62591	35	BP1600-S/S	76346	152	CART-54/1350-S/S	78581	92	CART2-96/2400-S/S	78587	99
ACME-PRK	62496	35	BP1800	73117	152	CART-54/1350-S/S	78581	97	CBC18	76668	117
ACME-PRK	62496	35	BP1800-B	73785	153	CART-54/1350-S/S	78581	98	CBC24	76669	117
ACME-PRK	62496	35	BP1800-PL	73121	153	CART-60/1500-S/S	78582	41	CBC30	76670	117
ACME-PRK	62496	35	BP1800-PL-S/S	A1547	153	CART-60/1500-S/S	78582	46	CBC36	76671	117
AIR BAG P	62036	35	BP1800-S/S	76347	152	CART-60/1500-S/S	78582	76	CBC3R	90641	117
AIR HARK-S/S-60	62035	35	BP1800MF	73148	153	CART-60/1500-S/S	78582	78	CBC4	76672	117
AIR HARK-S/S-73	64175	35	BP1800MF-S/S MAIN FRAME	A1546	153	CART-60/1500-S/S	78582	83	CBC48	76673	117
AIR HDMRK S/S	62034	35	BP2000MF	A1996	153	CART-60/1500-S/S	78582	85	CBC54	76674	117
ATV-ANGLE	62426	71	BP450	73102	152	CART-60/1500-S/S	78582	90	CBC60	76675	117
ATV-ANGLE	62426	91	BP450-750-PL	73109	153	CART-60/1500-S/S	78582	92	CBCS18	90537	117
ATV-BAG	62079	71	BP450-750-PL-S/S	A0683	153	CART-60/1500-S/S	78582	97	CBCS24	90538	117
ATV-BAG	62079	91	BP450-750MF	73152	153	CART-60/1500-S/S	78582	98	CBCS30	90539	117
ATV-MOUNT	62424	71	BP450-750MF-S/S MAIN FRAME	A0682	153	CART-72/1800-S/S	78583	41	CBCS36	90540	117
ATV-MOUNT	63073	71	BP450-B	74055	153	CART-72/1800-S/S	78583	46	CBCS42	90541	117
ATV-MOUNT	62424	91	BP450-S/S	76337	152	CART-72/1800-S/S	78583	76	CBCS48	90542	117
ATV-MOUNT	63073	91	BP600	73104	152	CART-72/1800-S/S	78583	78	CBCS54	90543	117
ATV-NIP	62037	35	BP600-B	73777	153	CART-72/1800-S/S	78583	83	CBCS60	90544	117
ATV-NIP	62037	71	BP600-S/S	76338	152	CART-72/1800-S/S	78583	85	CBD-L	76444	158
ATV-NIP	62037	91	BP750	73106	152	CART-72/1800-S/S	78583	90	CBD-L-S/S	A1856	158
ATV-SLIDE	62425	71	BP750-B	73778	153	CART-72/1800-S/S	78583	92	CBD-M	76443	158
ATV-SLIDE	62425	91	BP750-S/S	76339	152	CART-72/1800-S/S	78583	97	CBD-M-S/S	A1854	158
ATV-TUBE	66068	71	BP800	73107	152	CART-72/1800-S/S	78583	98	CBD-S	76442	158
ATV-TUBE	66068	91	BP800-1050-PL	73111	153	CART-120/3000-S/S	78588	76	CBD-S-S/S	64178	158
ATV73-SS	66192	71	BP800-1050-PL-S/S	A0613	153	CART-120/3000-S/S	78588	78	CBD-ST-AA	61096	159
ATV73-SS	66192	91	BP800-1050MF	73153	153	CART-120/3000-S/S	78588	83	CBD-ST-B	64620	159
ATVK-60	62409	71	BP800-1050MF-S/S MAIN FRAME	A0612	153	CART-120/3000-S/S	78588	85	CBD-ST-BB	64310	159
ATVK-60	62409	91	BP800-B	74057	153	CART-120/3000-S/S	78588	90	CBD-ST-CS-S/S	A2215	159
ATVK-73	63072	71	BP800-S/S	76340	152	CART-120/3000-S/S	78588	92	CBD-ST-FR-B	61111	159
ATVK-73	63072	91	BP900	73108	152	CART-120/3000-S/S	78588	97	CBD-ST-L	61050	159
ATVK73-SEC-SS	64743	71	BP900-B	73779	153	CART-120/3000-S/S	78588	99	CBD-ST-L-B	64621	159
ATVK73-SEC-SS	64743	91	BP900-S/S	76341	152	CART-120/3000-S/S	78588	41	CBD-ST-L-FP	61113	159
ATVKP-60	63861	71	C-PSTA	81045	104	CART-48/1200-S/S	78580	46	CBD-ST-L-FR-B	A2218	159
ATVKP-60	63861	91	CART-24/600-S/S	78576	41	CART-60/1500-S/S	78584	42	CBD-ST-L-MF	61106	159
ATVKP-73	63862	71	CART-24/600-S/S	78576	46	CART-60/1500-S/S	78584	47	CBD-ST-L-MF-S/S	61109	159
ATVKP-73	63862	91	CART-24/600-S/S	78576	76	CART-60/1500-S/S	78584	76	CBD-ST-L-P	64773	159
AWT	75904	30	CART-24/600-S/S	78576	78	CART-60/1500-S/S	78584	78	CBD-ST-L-P-S/S	64624	159
AWT	75904	36	CART-24/600-S/S	78576	83	CART-60/1500-S/S	78584	83	CBD-ST-L-PS	64777	159
AWT-1S	76375	30	CART-24/600-S/S	78576	85	CART-60/1500-S/S	78584	85	CBD-ST-L-PS-S/S	64781	159
AWT-1S	76375	36	CART-24/600-S/S	78576	90	CART-60/1500-S/S	78584	90	CBD-ST-L-S	64785	159
AWTA	75907	30	CART-24/600-S/S	78576	92	CART-60/1500-S/S	78584	92	CBD-ST-L-S/S	61080	159
AWTA	75907	36	CART-24/600-S/S	78576	97	CART-60/1500-S/S	78584	97	CBD-ST-M	61077	159
AWTB	75905	30	CART-24/600-S/S	78576	98	CART-60/1500-S/S	78584	99	CBD-ST-M-FP	61112	159
AWTB	75905	36	CART-30/750-S/S	78577	76	CART-66/1650-S/S	78634	42	CBD-ST-M-MF	61105	159
AWTCB	75908	30	CART-30/750-S/S	78577	78	CART-66/1650-S/S	78634	47	CBD-ST-M-MF-S/S	61108	159
AWTCB	75908	36	CART-30/750-S/S	78577	83	CART-72/1800-S/S	78585	42	CBD-ST-M-P	64772	159
AWTHK	75909	30	CART-30/750-S/S	78577	85	CART-72/1800-S/S	78585	47	CBD-ST-M-P-S/S	64623	159
AWTHK	75909	36	CART-30/750-S/S	78577	90	CART-72/1800-S/S	78585	76	CBD-ST-M-PS-S/S	64780	159
AWTMB	75906	30	CART-30/750-S/S	78577	92	CART-72/1800-S/S	78585	78	CBD-ST-M-PSS	64776	159
AWTMB	75906	36	CART-30/750-S/S	78577	97	CART-72/1800-S/S	78585	83	CBD-ST-M-S	64784	159
AWTNCB	76069	30	CART-30/750-S/S	78577	98	CART-72/1800-S/S	78585	85	CBD-ST-M-S/S	61079	159
AWTNCB	76069	36	CART-36/900-S/S	78578	41	CART-72/1800-S/S	78585	90	CBD-ST-MC	B0092	159
BP-LA	73127	153	CART-36/900-S/S	78578	46	CART-72/1800-S/S	78585	92	CBD-ST-TB-S/S	A2629	159

# INDEX By Ordering Number

Ordering Number	Item Code	Page #	Ordering Number	Item Code	Page #	Ordering Number	Item Code	Page #	Ordering Number	Item Code	Page #
CBD-ST-XL	61051	159	CBS600P	104414	114	CCKHDL-S/S	79227	59	CRB-HT22	76595	18
CBD-ST-XL-B	64482	159	CBS600P-S/S	106570	114	CCKHDL-S/S	79227	61	CRB-HT28	76596	18
CBD-ST-XL-FP	61114	159	CBS60SC	108467	112	CCKHDL-S/S	79227	68	CRB-HT34	76597	18
CBD-ST-XL-FR-B	A1784	159	CBS60SC	111981	112	CCKHDL-S/S	79227	114	CRB-HT40	76598	18
CBD-ST-XL-MF	61107	159	CBS60SF	84130	112	CCKHDR	79229	59	CRB-HT46	76599	18
CBD-ST-XL-MF-S/S	61110	159	CBS60SF	102132	112	CCKHDR	79229	61	CRB-HT52	76600	18
CBD-ST-XL-P	64774	159	CBS72SC	108468	112	CCKHDR	79229	68	CRB-HT58	76601	18
CBD-ST-XL-P-S/S	64625	159	CBS72SC	111982	112	CCKHDR	79229	114	CRB-HT64	76602	18
CBD-ST-XL-PS	64778	159	CBS72SF	84131	112	CCKHDR-S/S	79231	59	CRB-HT70	76603	18
CBD-ST-XL-PS-S/S	64782	159	CBS72SF	102133	112	CCKHDR-S/S	79231	61	CRB-LS10	77088	13
CBD-ST-XL-S	63024	159	CBS750P	104415	114	CCKHDR-S/S	79231	68	CRB-LS10W	77097	13
CBD-ST-XL-S/S	A2138	159	CBS750P-S/S	106571	114	CCKHDR-S/S	79231	114	CRB-LS16	77089	13
CBD-ST-XXL	63747	159	CBS84SF	84132	112	CCKHDT	79233	59	CRB-LS16HT	77552	13
CBD-ST-XXL-B	64622	159	CBS84SF	102134	112	CCKHDT	79233	61	CRB-LS16W	77098	13
CBD-ST-XXL-FP	63751	159	CBS900P	104416	114	CCKHDT	79233	68	CRB-LS22	77090	13
CBD-ST-XXL-FR-B	63752	159	CBS900P-S/S	106572	114	CCKHDT	79233	114	CRB-LS22HT	77553	13
CBD-ST-XXL-MF	63749	159	CBS96SC	108470	112	CCKHDT-S/S	73235	59	CRB-LS22W	77099	13
CBD-ST-XXL-MF-S/S	63750	159	CBS96SC	111984	112	CCKHDT-S/S	73235	61	CRB-LS28	77091	13
CBD-ST-XXL-P	64775	159	CBS96SF	84133	112	CCKHDT-S/S	73235	68	CRB-LS28HT	77554	13
CBD-ST-XXL-P-S/S	64626	159	CBS96SF	102135	112	CCKHDT-S/S	79232	114	CRB-LS28W	77100	13
CBD-ST-XXL-PS	64779	159	CBSBLD18C	91527	112	CCKL	79224	59	CRB-LS34	77092	13
CBD-ST-XXL-PS-S/S	64783	159	CBSBLD18F	79947	112	CCKL	79224	61	CRB-LS34HT	77555	13
CBD-ST-XXL-S	63791	159	CBSBLD24C	91528	112	CCKL-S/S	79226	59	CRB-LS34W	77101	13
CBD-ST-XXL-S/S	63748	159	CBSBLD24F	79948	112	CCKL-S/S	79226	61	CRB-LS40	77093	13
CBD-XL	76445	158	CBSBLD30C	91529	112	CCKR	79228	59	CRB-LS40HT	77556	13
CBD-XL-S/S	76318	158	CBSBLD30F	79949	112	CCKR	79228	61	CRB-LS40W	77102	13
CBD-XXL	64787	158	CBSBLD36C	91530	112	CCKR-S/S	79230	59	CRB-LS46	77094	13
CBD-XXL-S/S	63554	158	CBSBLD36F	79950	112	CCKR-S/S	79230	61	CRB-LS46HT	77557	13
CBR-L	72485	158	CBSBLD42C	91531	112	CCKTS	79232	59	CRB-LS46W	77103	13
CBR-M	72484	158	CBSBLD42F	79951	112	CCKTS	79232	61	CRB-LS52	77095	13
CBR-S	72483	158	CBSBLD48C	91532	112	CCKTS-S/S	79234	59	CRB-LS52HT	77558	13
CBR-XL	72486	158	CBSBLD48F	79952	112	CCKTS-S/S	79234	61	CRB-LS52W	77104	13
CBS-1050-BT	103248	112	CBSBLD54C	91533	112	CCMK	78919	51	CRB-LS58	77096	13
CBS-1050-BT	106597	112	CBSBLD54F	79953	112	CCMK	78919	59	CRB-LS58HT	77559	13
CBS-1200-BT	103249	112	CBSBLD60C	91534	112	CCMK	78919	61	CRB-LS58W	77105	13
CBS-1200-BT	106598	112	CBSBLD60F	79954	112	CCMK-S/S	78921	59	CRB-UHT-1000	91258	18
CBS-1350-BT	103250	112	CBSBLD72C	91535	112	CCMK-S/S	78921	61	CRB-UHT-1150	91259	18
CBS-1350-BT	106599	112	CBSBLD72F	79955	112	CCMKHD	78920	55	CRB-UHT-1300	91260	18
CBS-450-BT	103244	112	CBSBLD84C	91536	112	CCMKHD	78920	59	CRB-UHT-1450	91261	18
CBS-450-BT	106593	112	CBSBLD84F	79956	112	CCMKHD	78920	61	CRB-UHT-1750	91263	18
CBS-600-BT	103245	112	CBSBLD96C	91537	112	CCMKHD	78920	68	CRB-UHT-400	91254	18
CBS-600-BT	106594	112	CBSBLD96F	79957	112	CCMKHD	78920	114	CRB-UHT-550	91255	18
CBS-750-BT	103246	112	CBSC-1050-BT	108460	112	CCMKHD-S/S	78922	59	CRB-UHT-700	91256	18
CBS-750-BT	106595	112	CBSC-1050-BT	111967	112	CCMKHD-S/S	78922	61	CRB-UHT-850	91257	18
CBS-900-BT	103247	112	CBSC-1200-BT	108461	112	CCMKHD-S/S	78922	68	CRB-W16	78472	18
CBS-900-BT	106596	112	CBSC-1200-BT	111968	112	CCMKHD-S/S	78922	114	CRB-W22	78473	18
CBS1050P	104417	114	CBSC-1350-BT	108462	112	CDWB24	75884	110	CRB-W28	78474	18
CBS1050P-S/S	106573	114	CBSC-1350-BT	111969	112	CDWB30	75885	110	CRB-W34	78475	18
CBS1200P	104418	114	CBSC-450-BT	108456	112	CDWB36	75886	110	CRB-W40	78476	18
CBS1200P-S/S	106574	114	CBSC-450-BT	111963	112	CDWB42	75887	110	CRB-W46	78477	18
CBS1350P	104419	114	CBSC-600-BT	108457	112	CDWB48	75888	110	CRB-W52	78478	18
CBS1350P-S/S	106575	114	CBSC-600-BT	111964	112	CDWB54	75889	110	CRB-W58	78479	18
CBS18SC	91495	112	CBSC-750-BT	108458	112	CDWB60	75890	110	CRB-W64	78480	18
CBS18SF	79936	112	CBSC-750-BT	111965	112	CDWB72	75891	110	CRB-W70	78481	18
CBS18SF	111752	112	CBSC-900-BT	108459	112	CDWB84	76942	110	CRB16	75629	18
CBS24SC	91496	112	CBSC-900-BT	111966	112	CDWB96	79062	110	CRB22	75630	18
CBS24SC	111975	112	CBSCHD-1500-BT	108463	112	CEBC-1	30018	134	CRB28	75631	18
CBS24SF	79937	112	CBSCHD-1500-BT	111970	112	CEBC-1-NC	108848	134	CRB34	75632	18
CBS24SF	111753	112	CBSCHD-1800-BT	108464	112	CEBC-2	30019	134	CRB40	75633	18
CBS30SC	91497	112	CBSCHD-1800-BT	111971	112	CEBC-2-NC	108849	134	CRB46	75634	18
CBS30SC	111976	112	CBSCHD-2100-BT	108465	112	CEBC1 Case	30020	134	CRB52	75635	18
CBS30SF	79938	112	CBSCHD-2100-BT	111972	112	CEBC2 Case	30023	134	CRB58	75636	18
CBS30SF	111754	112	CBSCHD-2400-BT	108466	112	CFG-212	78838	14	CRB64	75775	18
CBS36SC	91498	112	CBSCHD-2400-BT	111973	112	CFG-218	78839	14	CRB70	75773	18
CBS36SC	111977	112	CBSHD-1500-BT	103255	112	CFG-224	78840	14	CRDF18	90631	117
CBS36SF	79939	112	CBSHD-1500-BT	103259	112	CFG-230	78841	14	CRDF24	90632	117
CBS36SF	111755	112	CBSHD-1500P	84086	114	CFG-236	78842	14	CRDF30	90633	117
CBS42SC	91499	112	CBSHD-1800-BT	84116	114	CFG-242	78843	14	CRDF36	90634	117
CBS42SC	111978	112	CBSHD-1800-BT	103256	112	CFG-248	78844	14	CRDF42	90635	117
CBS42SF	79940	112	CBSHD-1800-BT	103260	112	CFG-254	78845	14	CRDF48	90636	117
CBS42SF	111756	112	CBSHD-1800P	84087	114	CFG-260	78846	14	CRDF54	90637	117
CBS450P	104413	114	CBSHD-1800P	84117	114	CFG-272	78847	14	CRDF60	90638	117
CBS450P-S/S	106569	114	CBSHD-2100-BT	103257	112	CLSGF-212	77144	10	CRDLBLK-LH-S/S	A2826	79
CBS48SC	91500	112	CBSHD-2100-BT	103261	112	CLSGF-218	77145	10	CRDLBLK-LH-S/S	A2826	86
CBS48SF	111979	112	CBSHD-2100P	84088	114	CLSGF-224	77146	10	CRDLBLK-LH-S/S	A2826	99
CBS48SF	79941	112	CBSHD-2100P	84118	114	CLSGF-230	77147	10	CRDLBLK-RH-S/S	A2825	79
CBS48SF	111757	112	CBSHD-2400-BT	103258	112	CLSGF-236	77148	10	CRDLBLK-RH-S/S	A2825	86
CBS54SC	91501	112	CBSHD-2400-BT	103262	112	CLSGF-242	77149	10	CRDLBLK-RH-S/S	A2825	99
CBS54SC	108469	112	CBSHD-2400P	84089	114	CLSGF-248	77150	10	CRHMK	62400	77
CBS54SC	111980	112	CBSHD-2400P	84119	114	CLSGF-254	77151	10	CRHMK	62400	84
CBS54SC	111983	112	CCKHDL	79225	59	CLSGF-260	77152	10	CRHMK	62400	97
CBS54SF	79942	112	CCKHDL	79225	61	CPB	76692	117	CRHMK-S/S	62095	79
CBS54SF	111758	112	CCKHDL	79225	68	CRB-HT10	76593	18	CRHMK-S/S	62095	86
						CRB-HT16	76594	18	CRHMK-S/S	62095	99

# INDEX By Ordering Number

Ordering Number	Item Code	Page #	Ordering Number	Item Code	Page #	Ordering Number	Item Code	Page #	Ordering Number	Item Code	Page #
CST1HDM-B	78515	91	DRXL-30-535	76841	147	EBC2-RK	30034	134	EZIB600-1200M-LP	68187	143
CST1HDM-B-S/S	78392	93	DRXL-36-420	76818	147	ESBK-ATEX	90264	17	EZIB600-1500L-LP	68179	140
CST1HDM-G	78516	91	DRXL-36-435	76834	147	ESBK-B	76411	16	EZIB600-1500M-LP	68195	143
CST1HDM-G-S/S	78393	93	DRXL-36-520	76826	147	ESBK-B	76411	17	EZIB750-1200L-LP	68172	140
CST1HDM-S	78514	91	DRXL-36-535	76842	147	ESBK-B EST	76411	17	EZIB750-1200M-LP	68188	143
CST1HDM-S-S/S	78391	93	DRXL-42-420	76819	147	ESBK-PS	76410	16	EZIB750-1500L-LP	68180	140
CST1HDM-W	78513	91	DRXL-42-435	76835	147	ESBK-PS	76410	17	EZIB750-1500M-LP	68196	143
CST1HDM-W-S/S	78390	93	DRXL-42-520	76827	147	ESPBK	76408	16	EZIB900-1200L-LP	68173	140
CSTAK	77031	91	DRXL-42-535	76843	147	ESPRK	76409	16	EZIB900-1200M-LP	68189	143
CSTAK	77031	93	DRXL-48-420	76820	147	ESPSBK	76407	16	EZIB900-1500L-LP	68181	140
CSTBK	77037	91	DRXL-48-435	76836	147	ESS-B	76413	16	EZIB900-1500M-LP	68197	143
CSTBK	77037	93	DRXL-48-520	76828	147	ESS-S	76412	16	EZP-LS212	77127	10
CSTHDMK	77871	91	DRXL-48-535	76844	147	ESS-S	76412	104	EZP-LS212-S/S	62836	10
CSTHDMK-S/S	78384	93	DRXL-54-420	76821	147	ESS-S-S/S	79288	105	EZP-LS212HT	77746	10
CSTHDFM	77869	91	DRXL-54-435	76837	147	EST-B	109469	16	EZP-LS212HT-S/S	62845	10
CSTHDFM-S/S	78389	93	DRXL-54-520	76829	147	EST-G-S/S	78810	17	EZP-LS218	77128	10
CTS-B	77744	91	DRXL-54-535	76845	147	EST-G-S/S-UHT	66995	17	EZP-LS218-S/S	62837	10
CTS-B-S/S	78387	12	DRXL-60-420	76822	147	EST-P	109467	16	EZP-LS218HT	77747	10
CTS-B-S/S	78387	93	DRXL-60-435	76838	147	EST-P-S/S	78808	17	EZP-LS218HT-S/S	62846	10
CTS-G	77745	91	DRXL-60-520	76830	147	EST-P-S/S-UHT	66993	17	EZP-LS224	77129	10
CTS-G-S/S	78388	93	DRXL-60-535	76846	147	EST-S	109468	16	EZP-LS224-S/S	62838	10
CTS-S	77743	51	DRXL-72-420	76823	147	EST-W-S/S	78809	17	EZP-LS224HT	77748	10
CTS-S	77743	91	DRXL-72-435	76839	147	EST-W-S/S-UHT	66994	17	EZP-LS224HT-S/S	62847	10
CTS-S-S/S	78386	93	DRXL-72-520	76831	147	ESTAK	76406	16	EZP-LS230	77130	10
CTS-W	77742	91	DRXL-72-535	76847	147	ESTAK	76406	104	EZP-LS230-S/S	62839	10
CTS-W-S/S	78385	93	DRXM-24-420	88363	148	ESTAK-EST	76406	35	EZP-LS230HT	77749	10
DBK-L	76448	158	DRXM-24-435	88365	148	ESTAK-EST-S/S	78849	17	EZP-LS230HT-S/S	62848	10
DBK-M	76447	158	DRXM-24-520	88364	148	ESTAK-EST-S/S	78849	35	EZP-LS236	77131	10
DBK-S	76446	158	DRXM-24-535	88366	148	ESTAK-SS	78849	105	EZP-LS236-S/S	62840	10
DBK-XL	76449	158	DRXM-30-420	88367	148	EZBMK-1050	82284	141	EZP-LS236HT	77750	10
DBK-XXL	62595	158	DRXM-30-435	88369	148	EZBMK-1050	82284	144	EZP-LS236HT-S/S	62849	10
DRXD-42-520	76912	150	DRXM-30-520	88368	148	EZBMK-1200	82285	141	EZP-LS242	77132	10
DRXD-42-535	76919	150	DRXM-30-535	88370	148	EZBMK-1200	82285	144	EZP-LS242-S/S	62841	10
DRXD-48-520	76913	150	DRXM-36-420	88371	148	EZBMK-1350	82286	141	EZP-LS242HT	77751	10
DRXD-48-535	76920	150	DRXM-36-435	88373	148	EZBMK-1350	82286	144	EZP-LS242HT-S/S	62850	10
DRXD-54-520	76914	150	DRXM-36-520	88372	148	EZBMK-1500	82287	141	EZP-LS248	77133	10
DRXD-54-535	76921	150	DRXM-36-535	88374	148	EZBMK-1500	82287	144	EZP-LS248-S/S	62842	10
DRXD-60-520	76915	150	DRXM-42-420	88375	148	EZBMK-1800	82288	141	EZP-LS248HT	77752	10
DRXD-60-535	76922	150	DRXM-42-435	88377	148	EZBMK-1800	82288	144	EZP-LS248HT-S/S	62851	10
DRXD-72-520	76916	150	DRXM-42-520	88376	148	EZBMK-600	82281	141	EZP-LS254	77134	10
DRXD-72-535	76923	150	DRXM-42-535	88378	148	EZBMK-600	82281	144	EZP-LS254-S/S	62843	10
DRXD-84-520	76917	150	DRXM-48-420	88379	148	EZBMK-750	82282	141	EZP-LS254HT	77753	10
DRXD-84-535	76924	150	DRXM-48-435	88381	148	EZBMK-750	82282	144	EZP-LS254HT-S/S	62852	10
DRXD-96-520	76918	150	DRXM-48-520	88380	148	EZBMK-900	82283	141	EZP-LS260	77135	10
DRXD-96-535	76925	150	DRXM-48-535	88382	148	EZBMK-900	82283	144	EZP-LS260-S/S	62844	10
DRXH-24-420	81315	149	DRXM-54-420	88383	148	EZBS-1200	82361	141	EZP-LS260HT	77754	10
DRXH-24-435	81317	149	DRXM-54-435	88385	148	EZBS-1500	82362	141	EZP-LS260HT-S/S	62853	10
DRXH-24-520	81316	149	DRXM-54-520	88384	148	EZCSK-1050	82356	137	EZP1-218	75611	14
DRXH-24-535	81318	149	DRXM-54-535	88386	148	EZCSK-1050	82356	139	EZP1-218-S/S	61081	14
DRXH-30-420	81319	149	DRXM-60-420	88387	148	EZCSK-1200	82357	137	EZP1-224	75612	14
DRXH-30-435	81321	149	DRXM-60-435	88389	148	EZCSK-1200	82357	139	EZP1-224-S/S	61082	14
DRXH-30-520	81320	149	DRXM-60-520	88388	148	EZCSK-1350	82358	137	EZP1-230	75613	14
DRXH-30-535	81322	149	DRXM-60-535	88390	148	EZCSK-1350	82358	139	EZP1-230-S/S	61017	14
DRXH-36-420	81323	149	DRXM-72-420	88391	148	EZCSK-1500	82359	137	EZP1-236	75614	14
DRXH-36-435	81325	149	DRXM-72-435	88393	148	EZCSK-1500	82359	139	EZP1-236-S/S	61083	14
DRXH-36-520	81324	149	DRXM-72-520	88392	148	EZCSK-1800	82360	137	EZP1-242	75615	14
DRXH-36-535	81326	149	DRXM-72-535	88394	148	EZCSK-1800	82360	139	EZP1-242-S/S	61016	14
DRXH-42-420	81327	149	DVC-CLRI-AU	91602	125	EZCSK-600	82353	137	EZP1-248	75616	14
DRXH-42-435	81329	149	DVC-SUB-N-AU	109370	125	EZCSK-600	82353	139	EZP1-248-S/S	61084	14
DRXH-42-520	81328	149	DVC-SUB-U-AU	103971	125	EZCSK-750	82354	137	EZP1-254	75617	14
DRXH-42-535	81330	149	DVCR-CLR-ADT	91597	125	EZCSK-750	82354	139	EZP1-254-S/S	61085	14
DRXH-48-420	81331	149	DVCR-CLR-BC1AU	91603	125	EZCSK-900	82355	137	EZP1-260	75618	14
DRXH-48-435	81333	149	DVCR-CLR-BC2	91604	125	EZCSK-900	82355	139	EZP1-260-S/S	61086	14
DRXH-48-520	81332	149	DVCR-CLR-BTR1	91605	125	EZCSK-900	82355	139	EZP1-272	75771	14
DRXH-48-535	81334	149	DVCR-CLR-EX60	91596	125	EZCSK-900	82355	137	EZP1-272-S/S	61087	14
DRXH-54-420	81335	149	DVCR-CLR-EX73	91595	125	EZCSK-900	82355	139	EZP1-UHT2-1050-S/S	66960	14
DRXH-54-435	81337	149	DVCR-CLR-TC1	91608	125	EZCSK-900	82355	137	EZP1-UHT2-1050-S/S	66961	14
DRXH-54-520	81336	149	DVCR-CLR-TC2	91606	125	EZCSK-900	82355	139	EZP1-UHT2-1200-S/S	66962	14
DRXH-54-535	81338	149	DVCR-CLR-TC3	91607	125	EZCSK-900	82355	137	EZP1-UHT2-1350-S/S	66963	14
DRXH-60-420	81339	149	DWP72	75883	109	EZCSK-900	82355	139	EZP1-UHT2-1500-S/S	66964	14
DRXH-60-435	81341	149	DWP72-S/S	67409	109	EZCSK-900	82355	137	EZP1-UHT2-1800-S/S	66965	14
DRXH-60-520	81340	149	DWP84	76815	109	EZCSK-900	82355	139	EZP1-UHT2-450-S/S	66956	14
DRXH-60-535	81342	149	DWP84-S/S	67486	109	EZCSK-900	82355	137	EZP1-UHT2-600-S/S	66957	14
DRXH-72-420	81343	149	DWP96	79060	109	EZCSK-900	82355	139	EZP1-UHT2-750-S/S	66958	14
DRXH-72-435	81345	149	DWP96-S/S	67487	109	EZCSK-900	82355	137	EZP1-UHT2-900-S/S	66959	14
DRXH-72-520	81344	149	EBC-1	30001	134	EZCSK-900	82355	139	EZP1BP	75642	16
DRXH-72-535	81346	149	EBC-1-B	30003	134	EZCSK-900	82355	137	EZP1BP	75642	20
DRXL-24-420	76816	147	EBC-1-NC	108846	134	EZCSK-900	82355	139	EZP1MPK	75637	16
DRXL-24-435	76832	147	EBC-2	30002	134	EZCSK-900	82355	137	EZP1MPK-S/S	78923	17
DRXL-24-520	76824	147	EBC-2-B	30004	134	EZCSK-900	82355	139	EZP1P12	75619	16
DRXL-24-535	76840	147	EBC-2-NC	108847	134	EZCSK-900	82355	137	EZP1P12-S/S	78812	17
DRXL-30-420	76817	147	EBC1 Case	30009	134	EZCSK-900	82355	139	EZP1P18	75620	16
DRXL-30-435	76833	147	EBC1-RK	30033	134	EZCSK-900	82355	137	EZP1P18	75620	20
DRXL-30-520	76825	147	EBC2 Case	30010	134	EZCSK-900	82355	139	EZP1P18-S/S	61182	17
						EBC2-RK	30034	134			
						ESBK-ATEX	90264	17			
						ESBK-B	76411	16			
						ESBK-B	76411	17			
						ESBK-B EST	76411	17			
						ESBK-PS	76410	16			
						ESBK-PS	76410	17			
						ESPBK	76408	16			
						ESPRK	76409	16			
						ESPSBK	76407	16			
						ESS-B	76413	16			
						ESS-S	76412	16			
						ESS-S	76412	104			
						ESS-S-S/S	79288	105			
						EST-B	109469	16			
						EST-G-S/S	78810	17			
						EST-G-S/S-UHT	66995	17			
						EST-P	109467	16			
						EST-P-S/S	78808	17			
						EST-P-S/S-UHT	66993	17			
						EST-S	109468	16			
						EST-W-S/S	78809	17			
						EST-W-S/S-UHT	66994	17			
						ESTAK	76406	16			
			</								

# INDEX By Ordering Number

Ordering Number	Item Code	Page #	Ordering Number	Item Code	Page #	Ordering Number	Item Code	Page #	Ordering Number	Item Code	Page #
EZP1P24	75621	16	EZSB600-1200I	82201	138	FMS-1350-EL15	65665	62	H-CARK-1400-CM-EL15	63644	43
EZP1P24	75621	20	EZSB600-1500C	82193	136	FMS-1350-EL15-S/S	65675	62	H-CARK-1400-CS	62548	38
EZP1P24-S/S	A2988	17	EZSB600-1500I	82209	138	FMS-1350V	79652	62	H-CARK-1400-CS-EL15	63643	43
EZP1P30	75622	16	EZSB750-1200C	82186	136	FMS-1350V-S/S	66111	62	H-CARK-1600-CL	62553	38
EZP1P30	75622	20	EZSB750-1200I	82202	138	FMS-1500-EL15	65666	62	H-CARK-1600-CL-EL15	63648	43
EZP1P30-S/S	A3041	17	EZSB750-1500C	82194	136	FMS-1500-EL15-S/S	65676	62	H-CARK-1600-CM	62552	38
EZP1P36	75623	16	EZSB750-1500I	82210	138	FMS-1500V	79653	62	H-CARK-1600-CM-EL15	63647	43
EZP1P36	75623	20	EZSB900-1200C	82187	136	FMS-1500V-S/S	66112	62	H-CARK-1600-CS	62551	38
EZP1P36-S/S	A3119	17	EZSB900-1200I	82203	138	FMS-1800-EL15	65667	62	H-CARK-1600-CS-EL15	63646	43
EZP1P42	75624	16	EZSB900-1500C	82195	136	FMS-1800-EL15-S/S	65677	62	H-CARK-1800-CL	62556	38
EZP1P42	75624	20	EZSB900-1500I	82211	138	FMS-1800V	79654	62	H-CARK-1800-CL-EL15	63651	43
EZP1P42-S/S	61183	17	EZWPK-1050	82348	137	FMS-1800V-S/S	66113	62	H-CARK-1800-CM	62555	38
EZP1P48	75625	16	EZWPK-1050	82348	139	FMS-600-EL15	65660	62	H-CARK-1800-CM-EL15	63650	43
EZP1P48	75625	20	EZWPK-1050	82348	141	FMS-600-EL15-S/S	65670	62	H-CARK-1800-CS	62554	38
EZP1P48-S/S	61491	17	EZWPK-1050	82348	144	FMS-600V	79647	62	H-CARK-1800-CS-EL15	63649	43
EZP1P54	75626	16	EZWPK-1200	82349	137	FMS-600V-S/S	66106	62	H-CARK-600-CL	62538	38
EZP1P54	75626	20	EZWPK-1200	82349	139	FMS-750-EL15	65661	62	H-CARK-600-CL-EL15	63633	43
EZP1P54-S/S	61184	17	EZWPK-1200	82349	141	FMS-750-EL15-S/S	65671	62	H-CARK-600-CM	62537	38
EZP1P60	75627	16	EZWPK-1200	82349	144	FMS-750V	79648	62	H-CARK-600-CM-EL15	63632	43
EZP1P60	75627	20	EZWPK-1350	82350	137	FMS-750V-S/S	66107	62	H-CARK-600-CS	62536	38
EZP1P60-S/S	61185	17	EZWPK-1350	82350	139	FMS-900-EL15	65662	62	H-CARK-600-CS-EL15	63631	43
EZP1P72	75772	16	EZWPK-1350	82350	141	FMS-900-EL15-S/S	65672	62	H-CARK-800-CL	62541	38
EZP1P72	75772	20	EZWPK-1350	82350	144	FMS-900V	79649	62	H-CARK-800-CL-EL15	63636	43
EZP1P72-S/S	61186	17	EZWPK-1500	82351	137	FMS-900V-S/S	66108	62	H-CARK-800-CM	62540	38
EZP1PL	75641	16	EZWPK-1500	82351	139	FMSC2	91444	64	H-CARK-800-CM-EL15	63635	43
EZP1PL	75641	20	EZWPK-1500	82351	141	FMSC2	91444	64	H-CARK-800-CS	62539	38
EZP1PL-S/S	78848	17	EZWPK-1500	82351	144	FRPU150	61742	59	H-CARK-800-CS-EL15	63634	43
EZP1T-212	78488	19	EZWPK-1800	82352	137	H CARK-1000-CL-S/S	62660	39	H-CARK2-1200-CL	62601	38
EZP1T-218	78489	19	EZWPK-1800	82352	139	H CARK-1000-CL-S/S-EL15	63660	44	H-CARK2-1200-CL-EL15	63569	43
EZP1T-224	78490	19	EZWPK-1800	82352	141	H CARK-1000-CM-S/S	62659	39	H-CARK2-1200-CL-S/S	62707	39
EZP1T-230	78491	19	EZWPK-1800	82352	144	H CARK-1000-CM-S/S-EL15	63659	44	H-CARK2-1200-CL-S/S-EL15	63601	44
EZP1T-236	78492	19	EZWPK-600	82345	137	H CARK-1000-CS-S/S	62658	39	H-CARK2-1200-CLL	62602	38
EZP1T-242	78493	19	EZWPK-600	82345	139	H CARK-1000-CS-S/S-EL15	63658	44	H-CARK2-1200-CLL-EL15	63570	43
EZP1T-248	78494	19	EZWPK-600	82345	141	H CARK-1200-CL-S/S	62663	39	H-CARK2-1200-CLL-S/S	62708	39
EZP1T-254	78495	19	EZWPK-600	82345	144	H CARK-1200-CL-S/S-EL15	63663	44	H-CARK2-1200-CLL-S/S-EL15	63602	44
EZP1T-260	78496	19	EZWPK-750	82346	137	H CARK-1200-CM-S/S	62662	39	H-CARK2-1200-CM	62600	38
EZP1T-272	78497	19	EZWPK-750	82346	139	H CARK-1200-CM-S/S-EL15	63662	44	H-CARK2-1200-CM-EL15	63568	43
EZPTBT	77384	20	EZWPK-750	82346	141	H CARK-1200-CS-S/S	62661	39	H-CARK2-1200-CM-S/S	62706	39
EZPTBTHD	77385	20	EZWPK-750	82346	144	H CARK-1200-CS-S/S-EL15	63661	44	H-CARK2-1200-CM-S/S-EL15	63600	44
EZPTCK	78508	20	EZWPK-900	82347	137	H CARK-1400-CL-S/S	62666	39	H-CARK2-1200-CS	62599	38
EZPTCKHD	78509	20	EZWPK-900	82347	139	H CARK-1400-CL-S/S-EL15	63666	44	H-CARK2-1200-CS-EL15	63567	43
EZPTMPK	78507	20	EZWPK-900	82347	141	H CARK-1400-CM-S/S	62665	39	H-CARK2-1200-CS-S/S	62705	39
EZPTSK	78511	20	EZWPK-900	82347	144	H CARK-1400-CM-S/S-EL15	63665	44	H-CARK2-1200-CS-S/S-EL15	63599	44
EZPTSKHD	78512	20	FCSBC S/S	68867	120	H CARK-1400-CS-S/S	62664	39	H-CARK2-1400-CL	62605	38
EZPTSR	78510	20	FL-PKIT-ML	77250	134	H CARK-1400-CS-S/S-EL15	63664	44	H-CARK2-1400-CL-EL15	63573	43
EZRKL-1050	68371	141	FL-PKIT-XL	77251	134	H CARK-1600-CL-S/S	62669	39	H-CARK2-1400-CL-S/S	62711	39
EZRKL-1050	68371	144	FLCK	77729	134	H CARK-1600-CL-S/S-EL15	63669	44	H-CARK2-1400-CL-S/S-EL15	63605	44
EZRKL-1200	68372	141	FLOP	76479	134	H CARK-1600-CM-S/S	62668	39	H-CARK2-1400-CLL	62606	38
EZRKL-1200	68372	144	FLEL-L	76473	134	H CARK-1600-CM-S/S-EL15	63668	44	H-CARK2-1400-CLL-EL15	63574	43
EZRKL-1350	68373	141	FLEL-M	76472	134	H CARK-1600-CS-S/S	62667	39	H-CARK2-1400-CLL-S/S	62712	39
EZRKL-1350	68373	144	FLEL-XL	76986	134	H CARK-1600-CS-S/S-EL15	63667	44	H-CARK2-1400-CLL-S/S-EL15	63606	44
EZRKL-1500	68374	141	FLELP	76474	134	H CARK-1800-CL-S/S	62672	39	H-CARK2-1400-CM	62604	38
EZRKL-1500	68374	144	FLL	76980	134	H CARK-1800-CL-S/S-EL15	63672	44	H-CARK2-1400-CM-EL15	63572	43
EZRKL-1800	68375	141	FLM	76979	134	H CARK-1800-CM-S/S	62671	39	H-CARK2-1400-CM-S/S	62710	39
EZRKL-1800	68375	144	FLRLB-L	76481	134	H CARK-1800-CM-S/S-EL15	63671	44	H-CARK2-1400-CM-S/S-EL15	63604	44
EZRKL-600	68368	141	FLRLB-M	76482	134	H CARK-1800-CS-S/S	62670	39	H-CARK2-1400-CS	62603	38
EZRKL-600	68368	144	FLRP	76478	134	H CARK-1800-CS-S/S-EL15	63670	44	H-CARK2-1400-CS-EL15	63571	43
EZRKL-750	68369	141	FLSC-CP	71057	173	H CARK-600-CL-S/S	62654	39	H-CARK2-1400-CS-S/S	62709	39
EZRKL-750	68369	144	FLSC-CP-S/S	A1438	173	H CARK-600-CL-S/S-EL15	63654	44	H-CARK2-1400-CS-S/S-EL15	63603	44
EZRKL-900	68370	141	FLSC-TP	71056	173	H CARK-600-CM-S/S	62653	39	H-CARK2-1600-CL	62608	38
EZRKL-900	68370	144	FLSC-TP-S/S	A1437	173	H CARK-600-CM-S/S-EL15	63653	44	H-CARK2-1600-CL-EL15	63576	43
EZRMKM	82344	137	FLSC2000	71053	173	H CARK-600-CS-S/S	62652	39	H-CARK2-1600-CL-S/S	62714	39
EZRMKM	82344	139	FLSC2000-CB	71061	173	H CARK-600-CS-S/S-EL15	63652	44	H-CARK2-1600-CL-S/S-EL15	63608	44
EZSB1050-1200C	82188	136	FLSC2000-CB-S/S	A1439	173	H CARK-800-CL-S/S	62657	39	H-CARK2-1600-CLL	62609	38
EZSB1050-1200I	82204	138	FLSC2000-MC	71059	173	H CARK-800-CL-S/S-EL15	63657	44	H-CARK2-1600-CLL-EL15	63577	43
EZSB1050-1500C	82196	136	FLSC2000-MC-S/S	A1440	173	H CARK-800-CM-S/S	62656	39	H-CARK2-1600-CLL-S/S	62715	39
EZSB1050-1500I	82212	138	FLSC2000-S/S	A1436	173	H CARK-800-CM-S/S-EL15	63656	44	H-CARK2-1600-CLL-S/S-EL15	63609	44
EZSB1200-1200C	82189	136	FLSCM-CP	71140	173	H CARK-800-CS-S/S	62655	39	H-CARK2-1600-CM	62607	38
EZSB1200-1200I	82205	138	FLSCM-CP-S/S	A2596	173	H CARK-800-CS-S/S-EL15	63655	44	H-CARK2-1600-CM-EL15	63575	43
EZSB1200-1500C	82197	136	FLSCM2000	71148	173	H-CARK-1000-CL	62544	38	H-CARK2-1600-CM-S/S	62713	39
EZSB1200-1500I	82213	138	FLSCM2000-S/S	61471	173	H-CARK-1000-CL-EL15	63639	43	H-CARK2-1600-CM-S/S-EL15	63607	44
EZSB1350-1200C	82190	136	FLTW-L	76477	134	H-CARK-1000-CM	62543	38	H-CARK2-1800-CL	62611	44
EZSB1350-1200I	82206	138	FLTW-M	76476	134	H-CARK-1000-CM-EL15	63638	43	H-CARK2-1800-CL-EL15	63579	43
EZSB1350-1500C	82198	136	FLTW-XL	76985	134	H-CARK-1000-CS	62542	38	H-CARK2-1800-CL-S/S	62717	39
EZSB1350-1500I	82214	138	FLVRL-XL	76984	134	H-CARK-1000-CS-EL15	63637	43	H-CARK2-1800-CL-S/S-EL15	63611	44
EZSB1500-1200C	82191	136	FLXL	76983	134	H-CARK-1200-CL	62547	38	H-CARK2-1800-CLL	62612	38
EZSB1500-1200I	82207	138	FMS-1050-EL15	65663	62	H-CARK-1200-CL-EL15	63642	43	H-CARK2-1800-CLL-EL15	63580	43
EZSB1500-1500C	82199	136	FMS-1050-EL15-S/S	65673	62	H-CARK-1200-CM	62546	38	H-CARK2-1800-CLL-S/S	62718	39
EZSB1500-1500I	82215	138	FMS-1050V	79650	62	H-CARK-1200-CM-EL15	63641	43	H-CARK2-1800-CLL-S/S-EL15	63612	44
EZSB1800-1200C	82192	136	FMS-1050V-S/S	66109	62	H-CARK-1200-CS	62545	38	H-CARK2-1800-CM	62610	38
EZSB1800-1200I	82208	138	FMS-1200-EL15	65664	62	H-CARK-1200-CS-EL15	63640	43	H-CARK2-1800-CM-EL15	63578	43
EZSB1800-1500C	82200	136	FMS-1200-EL15-S/S	65674	62	H-CARK-1400-CL	62550	38	H-CARK2-1800-CM-S/S	62716	39
EZSB1800-1500I	82216	138	FMS-1200V	79651	62	H-CARK-1400-CL-EL15	63645	43	H-CARK2-1800-CM-S/S-EL15	63610	44
EZSB600-1200C	82185	136	FMS-1200V-S/S	66110	62	H-CARK-1400-CM	62549	38	H-CARK2-2000-CL	62614	38



# INDEX By Ordering Number

Ordering Number	Item Code	Page #	Ordering Number	Item Code	Page #	Ordering Number	Item Code	Page #	Ordering Number	Item Code	Page #
H-CARK2-2000-CL-EL15	63582	43	H2CP-1400-S/S	62802	47	HBP1050-MF-TP-S/S	A2505	155	HCP-1000-S/S	62759	46
H-CARK2-2000-CL-S/S	62720	39	H2CP-1600	62765	42	HBP1050-PL-TP	A2295	155	HCP-1200	62754	41
H-CARK2-2000-CL-S/S-EL15	63614	44	H2CP-1600	62765	47	HBP1050-PL-TP-S/S	A2493	155	HCP-1200	62754	46
H-CARK2-2000-CLL	62615	38	H2CP-1600-S/S	62803	42	HBP1050-TP	A2284	154	HCP-1200-S/S	62760	41
H-CARK2-2000-CLL-EL15	63583	43	H2CP-1600-S/S	62803	47	HBP1200-B	73301	153	HCP-1200-S/S	62760	46
H-CARK2-2000-CLL-S/S	62721	39	H2CP-1800	62766	42	HBP1200-B-TP	A2318	155	HCP-1400	62755	41
H-CARK2-2000-CLL-S/S-EL15	63615	44	H2CP-1800	62766	47	HBP1200-MF-TP	A2307	155	HCP-1400	62755	46
H-CARK2-2000-CM	62613	38	H2CP-1800-S/S	62804	42	HBP1200-MF-TP-S/S	A2506	155	HCP-1400-S/S	62761	41
H-CARK2-2000-CM-EL15	63581	43	H2CP-1800-S/S	62804	47	HBP1200-PL-TP	A2296	155	HCP-1400-S/S	62761	46
H-CARK2-2000-CM-S/S	62719	39	H2CP-2000	62767	42	HBP1200-PL-TP-S/S	A2494	155	HCP-1800	62756	41
H-CARK2-2000-CM-S/S-EL15	63613	44	H2CP-2000	62767	47	HBP1200-TP	A2285	154	HCP-1800	62756	46
H-CARK2-2200-CL	62617	38	H2CP-2000-S/S	62805	42	HBP1400-B	73302	153	HCP-1800-S/S	62762	41
H-CARK2-2200-CL-EL15	63585	43	H2CP-2000-S/S	62805	47	HBP1400-B-TP	A2319	155	HCP-1800-S/S	62762	46
H-CARK2-2200-CLL-S/S	62723	39	H2CP-2400	62768	42	HBP1400-MF-TP	A2308	155	HCP-600	62751	41
H-CARK2-2200-CLL-S/S-EL15	63617	44	H2CP-2400	62768	47	HBP1400-MF-TP-S/S	A2507	155	HCP-600	62751	46
H-CARK2-2200-CLL	62618	38	H2CP-2400-S/S	62806	42	HBP1400-PL-TP	A2297	155	HCP-600-S/S	62757	41
H-CARK2-2200-CLL-EL15	63586	43	H2CP-2400-S/S	62806	47	HBP1400-PL-TP-S/S	A2495	155	HCP-600-S/S	62757	46
H-CARK2-2200-CLL-S/S	62724	39	H60CSK-B	62747	35	HBP1400-TP	A2286	154	HCP-800	62752	41
H-CARK2-2200-CLL-S/S-EL15	63618	44	H60CSK-B-S/S	62748	35	HBP1500-B	73303	153	HCP-800	62752	46
H-CARK2-2200-CM	62616	38	H60CSK-G	62741	35	HBP1500-B-TP	A2320	155	HCP-800-S/S	62758	41
H-CARK2-2200-CM-EL15	63584	43	H60CSK-G-S/S	62742	35	HBP1500-MF-TP	A2309	155	HCP-800-S/S	62758	46
H-CARK2-2200-CM-S/S	62722	39	H73BTK	74551	41	HBP1500-MF-TP-S/S	A2508	155	HCSBB-60	62513	35
H-CARK2-2200-CM-S/S-EL15	63616	44	H73BTK	74551	42	HBP1500-PL-TP	A2298	155	HCSBB-60	62513	35
H-CARK2-2400-CL	62620	38	H73BTK	74551	46	HBP1500-PL-TP-S/S	A2496	155	HCSBB-73	62514	35
H-CARK2-2400-CL-EL15	63588	43	H73BTK	74551	47	HBP1500-TP	A2287	154	HCSBB-73	62514	35
H-CARK2-2400-CLL-S/S	62726	39	H73BTK-S/S	63080	41	HBP1600-B	73304	153	HCSBB-B/G	62589	35
H-CARK2-2400-CLL-S/S-EL15	63620	44	H73BTK-S/S	63080	42	HBP1600-B-TP	A2321	155	HCSBB-B/G	62589	35
H-CARK2-2400-CLL	62621	38	H73BTK-S/S	63080	46	HBP1600-MF-TP	A2310	155	HCSBB-B/G	62589	35
H-CARK2-2400-CLL-EL15	63589	43	H73BTK-S/S	63080	47	HBP1600-MF-TP-S/S	A2509	155	HCSBB-B/G	62589	35
H-CARK2-2400-CLL-S/S	62727	39	H73CSK-B	62749	35	HBP1600-PL-TP	A2299	155	HCSBB-S	62590	35
H-CARK2-2400-CLL-S/S-EL15	63621	44	H73CSK-B	62749	37	HBP1600-PL-TP-S/S	A2497	155	HCSBB-S	62590	35
H-CARK2-2400-CM	62619	38	H73CSK-B	62749	41	HBP1600-TP	A2288	154	HCSTAK	62494	35
H-CARK2-2400-CM-EL15	63587	43	H73CSK-B	62749	42	HBP1800-B	73306	153	HCSTAK-S/S	62495	35
H-CARK2-2400-CM-S/S	62725	39	H73CSK-B	62749	46	HBP1800-B-TP	A2322	155	HCSTK-60-B	62747	37
H-CARK2-2400-CM-S/S-EL15	63619	44	H73CSK-B	62749	47	HBP1800-MF-TP	A2311	155	HCSTK-60-B-S/S	62748	37
H-SAC-AP-1000	62454	41	H73CSK-B-S/S	62750	35	HBP1800-MF-TP-S/S	A2510	155	HCSTK-60-G	62741	37
H-SAC-AP-1000	62454	42	H73CSK-B-S/S	62750	37	HBP1800-PL-TP	A2300	155	HCSTK-60-G-S/S	62742	37
H-SAC-AP-1000	62454	42	H73CSK-B-S/S	62750	41	HBP1800-PL-TP-S/S	A2498	155	HDARK	74550	37
H-SAC-AP-1000	62454	42	H73CSK-B-S/S	62750	42	HBP1800-TP	A2289	154	HDARK	77329	104
H-SAC-AP-1000	62454	42	H73CSK-B-S/S	62750	46	HBP2000-B	73307	153	HDARK-S/S	76247	37
H-SAC-AP-1000	62454	46	H73CSK-B-S/S	62750	47	HBP2000-B-TP	A2323	155	HDARK-S/S	77331	105
H-SAC-AP-1000	62454	47	H73CSK-G	62743	35	HBP2000-MF-TP	A2312	155	HDATDMK-S/S	63862	35
H-SAC-AP-1000	62454	47	H73CSK-G	62743	37	HBP2000-MF-TP-S/S	A2511	155	HDCK	74490	37
H-SAC-AP-1000	62454	47	H73CSK-G	62743	41	HBP2000-PL-TP	A2301	155	HDMK	74551	37
H-SAC-AP-1000	62454	47	H73CSK-G	62743	42	HBP2000-PL-TP-S/S	A2499	155	HDMK-S/S	76248	37
H-SAC-AP-1200	62455	41	H73CSK-G	62743	46	HBP2000-TP	A2290	154	HDMRK	74582	37
H-SAC-AP-1200	62455	42	H73CSK-G	62743	47	HBP2200-B	73308	153	HDMRK	74582	37
H-SAC-AP-1200	62455	42	H73CSK-G-S/S	62744	35	HBP2200-B-TP	A2325	155	HDMRK-S/S	76245	37
H-SAC-AP-1200	62455	42	H73CSK-G-S/S	62744	37	HBP2200-MF-TP	A2314	155	HDMRK-S/S	76245	37
H-SAC-AP-1200	62455	46	H73CSK-G-S/S	62744	41	HBP2200-MF-TP-S/S	A2512	155	HDPHC	61003	59
H-SAC-AP-1200	62455	47	H73CSK-G-S/S	62744	42	HBP2200-PL-TP	A2303	155	HDPHC	61003	77
H-SAC-AP-1200	62455	47	H73CSK-G-S/S	62744	46	HBP2200-PL-TP-S/S	A2500	155	HDPHSC-S/S	61001	59
H-SAC-AP-1200	62455	47	H73CSK-G-S/S	62744	47	HBP2200-TP	A2291	154	HDPHSC-S/S	61001	79
H-SAC-AP-1400	62456	41	H73CSK-S	62745	35	HBP2400-B	73309	153	HDR24	79010	121
H-SAC-AP-1400	62456	46	H73CSK-S	62745	42	HBP2400-B-TP	A2324	155	HDR30	79011	121
H-SAC-AP-1600	62457	41	H73CSK-S	62745	47	HBP2400-MF-TP	A2313	155	HDR36	79012	121
H-SAC-AP-1600	62457	46	H73CSK-S-S/S	62746	35	HBP2400-MF-TP-S/S	A2513	155	HDR42	79013	121
H-SAC-AP-1800	62458	41	H73CSK-S-S/S	62746	42	HBP2400-PL-TP	A2302	155	HDR48	79014	121
H-SAC-AP-1800	62458	46	H73CSK-S-S/S	62746	47	HBP2400-PL-TP-S/S	A2501	155	HDR54	79015	121
H-SAC-AP-600	62452	41	HARK	76406	37	HBP2400-TP	A2292	154	HDR60	79016	121
H-SAC-AP-600	62452	42	HARK	76406	104	HBP2500-B	73311	153	HDRBK	79009	121
H-SAC-AP-600	62452	42	HARK-S/S	75423	37	HBP2500-B-TP	A2326	155	HDRBK-HD	79072	121
H-SAC-AP-600	62452	42	HARK-S/S	77364	105	HBP2500-MF-TP	A2315	155	HDRGEK	79236	121
H-SAC-AP-600	62452	46	HATDMK-S/S	63861	35	HBP2500-MF-TP-S/S	A2514	155	HDRP15	64140	122
H-SAC-AP-600	62452	47	HBP-LA-TP	A2330	155	HBP2500-PL-TP	A2304	155	HDRP17	63679	122
H-SAC-AP-600	62452	47	HBP-LA-TP-S/S	A2515	155	HBP2500-PL-TP-S/S	A2502	155	HDRP22	63678	122
H-SAC-AP-600	62452	47	HBP-MB-TP	73922	155	HBP2500-TP	A2293	154	HDRR24	79019	121
H-SAC-AP-800	62453	41	HBP-MB-TP-S/S	A1155	155	HBP750-B	A0223	153	HDRR30	79020	121
H-SAC-AP-800	62453	42	HBP-SC-TP	74490	155	HBP900-B	A0224	153	HDRR36	79021	121
H-SAC-AP-800	62453	42	HBP-SC-TP-S/S	A2189	155	HBP900-B-TP	A2316	155	HDRR42	79022	121
H-SAC-AP-800	62453	42	HBP-TP-1050 S/S	A2475	154	HBP900-MF-TP	A2305	155	HDRR48	79023	121
H-SAC-AP-800	62453	42	HBP-TP-1200 S/S	A2476	154	HBP900-MF-TP-S/S	A2504	155	HDRR54	79024	121
H-SAC-AP-800	62453	46	HBP-TP-1400 S/S	A2477	154	HBP900-PL-TP	A2294	155	HDRR60	79025	121
H-SAC-AP-800	62453	47	HBP-TP-1500 S/S	A2478	154	HBP900-PL-TP-S/S	A2492	155	HDRRS72*	79026	121
H-SAC-AP-800	62453	47	HBP-TP-1600 S/S	A2479	154	HBP900-TP	A2283	154	HDRRS84*	79027	121
H-SAC-AP-800	62453	47	HBP-TP-1800 S/S	A2480	154	HBRK	73068	37	HDRS72*	79017	121
H-SAC-AP-800	62453	47	HBP-TP-2000 S/S	A2481	154	HBRK-S/S	75422	37	HDRS84*	79018	121
H2CP-1200	62763	42	HBP-TP-2200 S/S	A2482	154	HBRK-S/S-73	76246	35	HDSTCK-S/S	A2189	37
H2CP-1200	62763	47	HBP-TP-2400 S/S	A2483	154	HBRK-S/S-60	75422	35	HDSTKD	A2518	37
H2CP-1200-S/S	62801	42	HBP-TP-2500 S/S	A2484	154	HBRKX	74549	37	HDSTKD-S/S	A2519	37
H2CP-1200-S/S	62801	47	HBP-TP-900 S/S	A2474	154	HBRKX-S/S	76246	37	HDS	74502	104
H2CP-1400	62764	42	HBP1050-B	A2237	153	HCP-1000	62753	41	HDS-S/S	75586	105
H2CP-1400	62764	47	HBP1050-B-TP	A2317	155	HCP-1000	62753	46	HEX NUT	G1211	35
H2CP-1400-S/S	62802	42	HBP1050-MF-TP	A2306	155	HCP-1000-S/S	62759	41	HEX NUT	G1211	71



# INDEX By Ordering Number

Ordering Number	Item Code	Page #	Ordering Number	Item Code	Page #	Ordering Number	Item Code	Page #	Ordering Number	Item Code	Page #
HEX NUT	G1211	91	HSA8CM-S/S	62510	41	HV-1200-2SAC-CS	62557	38	HV-1800-SAC-CLL	62535	38
HEX Plug 3/4	61057	120	HSA8CM-S/S	62510	42	HV-1200-2SAC-CS-EL15	63421	43	HV-1800-SAC-CLL-EL15	63226	43
HMK	73054	37	HSA8CM-S/S	62510	45	HV-1200-2SAC-CS-S/S	62673	39	HV-1800-SAC-CLL-S/S	62651	39
HMK-S/S	75424	37	HSA8CM-S/S	62510	46	HV-1200-2SAC-CS-S/S-EL15	63453	44	HV-1800-SAC-CLL-S/S-EL15	63247	44
HP1050	73035	37	HSA8CM-S/S	62510	47	HV-1200-SAC-CL	62526	38	HV-1800-SAC-CM	62533	38
HP1050-S/S	75377	37	HSA8CS	62505	41	HV-1200-SAC-CL-EL15	63217	43	HV-1800-SAC-CM-EL15	63224	43
HP1200	73037	37	HSA8CS	62505	42	HV-1200-SAC-CL-S/S	62642	39	HV-1800-SAC-CM-S/S	62649	39
HP1200-S/S	75378	37	HSA8CS	62505	45	HV-1200-SAC-CS-S/S-EL15	63238	44	HV-1800-SAC-CM-S/S-EL15	63245	44
HP1500	73066	37	HSA8CS	62505	46	HV-1200-SAC-CM	62525	38	HV-2000-2SAC-CL	62572	38
HP1500-S/S	75379	37	HSA8CS	62505	47	HV-1200-SAC-CM-EL15	63216	43	HV-2000-2SAC-CL-EL15	63436	43
HP1600	73739	37	HSA8CS-S/S	62509	40	HV-1200-SAC-CM-S/S	62641	39	HV-2000-2SAC-CL-S/S	62688	39
HP1600-S/S	75380	37	HSA8CS-S/S	62509	41	HV-1200-SAC-CM-S/S-EL15	63237	44	HV-2000-2SAC-CL-S/S-EL15	63468	44
HP450	73027	37	HSA8CS-S/S	62509	42	HV-1200-SAC-CS	62524	38	HV-2000-2SAC-CLL	62573	38
HP450-S/S	75373	37	HSA8CS-S/S	62509	45	HV-1200-SAC-CS-EL15	63215	43	HV-2000-2SAC-CLL-EL15	63437	43
HP600	73029	37	HSA8CS-S/S	62509	46	HV-1200-SAC-CS-S/S	62640	39	HV-2000-2SAC-CLL-S/S	62689	39
HP600-S/S	75374	37	HSA8CS-S/S	62509	47	HV-1200-SAC-CS-S/S-EL15	63236	44	HV-2000-2SAC-CLL-S/S-EL15	63469	44
HP750	73031	37	HSA8L	73063	34	HV-1400-2SAC-CL	62563	38	HV-2000-2SAC-CM	62571	38
HP750-S/S	75375	37	HSA8L-S/S	73774	34	HV-1400-2SAC-CL-EL15	63427	43	HV-2000-2SAC-CM-EL15	63435	43
HP900	73033	37	HSA8LL	73064	34	HV-1400-2SAC-CL-S/S	62679	39	HV-2000-2SAC-CM-S/S	62687	39
HP900-S/S	75376	37	HSA8LL-S/S	74033	34	HV-1400-2SAC-CL-S/S-EL15	63459	44	HV-2000-2SAC-CM-S/S-EL15	63467	44
HPA1200	69469	128	HSA8M	73049	34	HV-1400-2SAC-CLL	62564	38	HV-2200-2SAC-CL	62575	38
HPA1350	69470	128	HSA8M-S/S	73773	34	HV-1400-2SAC-CLL-EL15	63428	43	HV-2200-2SAC-CL-EL15	63439	43
HPA1500	69471	128	HSA8S	73048	34	HV-1400-2SAC-CLL-S/S	62680	39	HV-2200-2SAC-CL-S/S	62691	39
HPA1600	69472	128	HSA8S-S/S	73772	34	HV-1400-2SAC-CLL-S/S-EL15	63460	44	HV-2200-2SAC-CL-S/S-EL15	63471	44
HPA1800	69473	128	HSA8SS	73047	34	HV-1400-2SAC-CM	62562	38	HV-2200-2SAC-CLL	62576	38
HPA2000	69474	128	HSA8SS-S/S	73771	34	HV-1400-2SAC-CM-EL15	63426	43	HV-2200-2SAC-CLL-EL15	63440	43
HPA2200	69475	128	HSA8SSS	75565	34	HV-1400-2SAC-CM-S/S	62678	39	HV-2200-2SAC-CLL-S/S	62692	39
HPA2400	69476	128	HSA8SSS-S/S	79655	34	HV-1400-2SAC-CM-S/S-EL15	63458	44	HV-2200-2SAC-CLL-S/S-EL15	63472	44
HPA2600	69477	128	HSHD	73483	37	HV-1400-2SAC-CS	62561	38	HV-2200-2SAC-CM	62574	38
HPA2800	69478	128	HSHD	73483	41	HV-1400-2SAC-CS-EL15	63425	43	HV-2200-2SAC-CM-EL15	63438	43
HPA3000	69479	128	HSHD	73483	42	HV-1400-2SAC-CS-S/S	62677	39	HV-2200-2SAC-CM-S/S	62690	39
HPHD1800	74601	37	HSHD	73483	46	HV-1400-2SAC-CS-S/S-EL15	63457	44	HV-2200-2SAC-CM-S/S-EL15	63470	44
HPHD1800-S/S	A2063	37	HSHD	73483	47	HV-1400-SAC-CL	62529	38	HV-2400-2SAC-CL	62578	38
HPHD2000	74547	37	HSHD-S/S	76467	37	HV-1400-SAC-CL-EL15	63220	43	HV-2400-2SAC-CL-EL15	63442	43
HPHD2000-S/S	A1783	37	HSHD-S/S	76467	41	HV-1400-SAC-CL-S/S	62645	39	HV-2400-2SAC-CL-S/S	62694	39
HPHD2400	74548	37	HSHD-S/S	76467	42	HV-1400-SAC-CL-S/S-EL15	63241	44	HV-2400-2SAC-CL-S/S-EL15	63474	44
HPHD2400-S/S	A2590	37	HSHD-S/S	76467	46	HV-1400-SAC-CM	62528	38	HV-2400-2SAC-CLL	62579	38
HPS8	73050	37	HSHD-S/S	76467	47	HV-1400-SAC-CM-EL15	63219	43	HV-2400-2SAC-CLL-EL15	63443	43
HSA	73486	37	HSTSS	61173	37	HV-1400-SAC-CM-S/S	62644	39	HV-2400-2SAC-CLL-S/S	62695	39
HSA200	73489	34	HTF212	76658	14	HV-1400-SAC-CM-S/S-EL15	63240	44	HV-2400-2SAC-CLL-S/S-EL15	63475	44
HSA200	73489	37	HTF212-S/S	62826	14	HV-1400-SAC-CS	62527	38	HV-2400-2SAC-CM	62577	38
HSA200	73489	40	HTF218	76659	14	HV-1400-SAC-CS-EL15	63218	43	HV-2400-2SAC-CM-EL15	63441	43
HSA200	73489	41	HTF218-S/S	62827	14	HV-1400-SAC-CS-S/S	62643	39	HV-2400-2SAC-CM-S/S	62693	39
HSA200	73489	42	HTF224	76660	14	HV-1400-SAC-CS-S/S-EL15	63239	44	HV-2400-2SAC-CM-S/S-EL15	63473	44
HSA200	73489	45	HTF224-S/S	62828	14	HV-1600-2SAC-CL	62566	38	HV-600-SAC-CL	62517	38
HSA200	73489	46	HTF230	76661	14	HV-1600-2SAC-CL-EL15	63430	43	HV-600-SAC-CL-EL15	63208	43
HSA200	73489	47	HTF230-S/S	62829	14	HV-1600-2SAC-CL-S/S	62682	39	HV-600-SAC-CL-S/S	62633	39
HSA200-EL15	76027	34	HTF236	76662	14	HV-1600-2SAC-CL-S/S-EL15	63462	44	HV-600-SAC-CL-S/S-EL15	63229	44
HSA200-EL15	76027	45	HTF236-S/S	62830	14	HV-1600-2SAC-CLL	62567	38	HV-600-SAC-CM	62516	38
HSA200-EL15	76027	46	HTF242	76663	14	HV-1600-2SAC-CLL-EL15	63431	43	HV-600-SAC-CM-EL15	63207	43
HSA200-EL15	76027	47	HTF242-S/S	62831	14	HV-1600-2SAC-CLL-S/S	62683	39	HV-600-SAC-CM-S/S	62632	39
HSA200-XL20	67775	34	HTF248	76664	14	HV-1600-2SAC-CLL-S/S-EL15	63463	44	HV-600-SAC-CM-S/S-EL15	63228	44
HSA8-CL	62507	40	HTF248-S/S	62832	14	HV-1600-2SAC-CM	62565	38	HV-600-SAC-CS	62515	38
HSA8-CLL	62508	40	HTF254	76665	14	HV-1600-2SAC-CM-EL15	63429	43	HV-600-SAC-CS-EL15	63206	43
HSA8-CM	62506	40	HTF254-S/S	62833	14	HV-1600-2SAC-CM-S/S	62681	39	HV-600-SAC-CS-S/S	62631	39
HSA8-CS	62505	40	HTF260	76666	14	HV-1600-2SAC-CM-S/S-EL15	63461	44	HV-600-SAC-CS-S/S-EL15	63227	44
HSA8CL	62507	41	HTF260-S/S	62834	14	HV-1600-SAC-CL	62531	38	HV-800-SAC-CL	62520	38
HSA8CL	62507	42	HTF272	76667	14	HV-1600-SAC-CL-EL15	63222	43	HV-800-SAC-CL-EL15	63211	43
HSA8CL	62507	45	HTF272-S/S	62835	14	HV-1600-SAC-CL-S/S	62647	39	HV-800-SAC-CL-S/S	62636	39
HSA8CL	62507	46	HTTS	74141	122	HV-1600-SAC-CL-S/S-EL15	63243	44	HV-800-SAC-CL-S/S-EL15	63232	44
HSA8CL	62507	47	HV-1000-SAC-CL	62523	38	HV-1600-SAC-CLL	62532	38	HV-800-SAC-CM	62519	38
HSA8CL-S/S	62511	40	HV-1000-SAC-CL-EL15	63214	43	HV-1600-SAC-CLL-EL15	63223	43	HV-800-SAC-CM-EL15	63210	43
HSA8CL-S/S	62511	41	HV-1000-SAC-CL-S/S	62639	39	HV-1600-SAC-CLL-S/S	62648	39	HV-800-SAC-CM-S/S	62635	39
HSA8CL-S/S	62511	42	HV-1000-SAC-CL-S/S-EL15	63235	44	HV-1600-SAC-CLL-S/S-EL15	63244	44	HV-800-SAC-CM-S/S-EL15	63231	44
HSA8CL-S/S	62511	45	HV-1000-SAC-CM	62522	38	HV-1600-SAC-CM	62530	38	HV-800-SAC-CS	62518	38
HSA8CL-S/S	62511	46	HV-1000-SAC-CM-EL15	63213	43	HV-1600-SAC-CM-EL15	63221	43	HV-800-SAC-CS-EL15	63209	43
HSA8CL-S/S	62511	47	HV-1000-SAC-CM-S/S	62638	39	HV-1600-SAC-CM-S/S	62646	39	HV-800-SAC-CS-S/S	62634	39
HSA8CLL	62508	41	HV-1000-SAC-CM-S/S-EL15	63234	44	HV-1600-SAC-CM-S/S-EL15	63242	44	HV-800-SAC-CS-S/S-EL15	63230	44
HSA8CLL	62508	42	HV-1000-SAC-CS	62521	38	HV-1800-2SAC-CL	62569	38	HV1050L	73179	32
HSA8CLL	62508	45	HV-1000-SAC-CS-EL15	63212	43	HV-1800-2SAC-CL-EL15	63433	43	HV1050L-PCST	63952	33
HSA8CLL	62508	46	HV-1000-SAC-CS-S/S	62637	39	HV-1800-2SAC-CL-S/S	62685	39	HV1050L-PCST-S/S	63994	33
HSA8CLL	62508	47	HV-1000-SAC-CS-S/S-EL15	63233	44	HV-1800-2SAC-CL-S/S-EL15	63465	44	HV1050L-S/S	75309	32
HSA8CLL-S/S	62512	40	HV-1200-2SAC-CL	62559	38	HV-1800-2SAC-CLL	62570	38	HV1050M	73036	32
HSA8CLL-S/S	62512	41	HV-1200-2SAC-CL-EL15	63423	43	HV-1800-2SAC-CLL-EL15	63434	43	HV1050M-PCST	63951	33
HSA8CLL-S/S	62512	42	HV-1200-2SAC-CL-S/S	62675	39	HV-1800-2SAC-CLL-S/S	62686	39	HV1050M-PCST-S/S	63993	33
HSA8CLL-S/S	62512	45	HV-1200-2SAC-CL-S/S-EL15	63455	44	HV-1800-2SAC-CLL-S/S-EL15	63466	44	HV1050M-S/S	75308	32
HSA8CLL-S/S	62512	46	HV-1200-2SAC-CLL	62560	38	HV-1800-2SAC-CM	62568	38	HV1050S	73056	32
HSA8CLL-S/S	62512	47	HV-1200-2SAC-CLL-EL15	63424	43	HV-1800-2SAC-CM-EL15	63432	43	HV1050S-PCST	63950	33
HSA8CM	62506	41	HV-1200-2SAC-CLL-S/S	62676	39	HV-1800-2SAC-CM-S/S	62684	39	HV1050S-PCST-S/S	63992	33
HSA8CM	62506	42	HV-1200-2SAC-CLL-S/S-EL15	63456	44	HV-1800-2SAC-CM-S/S-EL15	63464	44	HV1050S-S/S	75307	32
HSA8CM	62506	45	HV-1200-2SAC-CM	62558	38	HV-1800-SAC-CL	62534	38	HV1050SS	73057	32
HSA8CM	62506	46	HV-1200-2SAC-CM-EL15	63422	43	HV-1800-SAC-CL-EL15	63225	43	HV1050SS-PCST	64045	33
HSA8CM	62506	47	HV-1200-2SAC-CM-S/S	62674	39	HV-1800-SAC-CL-S/S	62650	39	HV1050SS-PCST-S/S	63991	33
HSA8CM-S/S	62510	40	HV-1200-2SAC-CM-S/S-EL15	63454	44	HV-1800-SAC-CL-S/S-EL15	63246	44	HV1050SS-S/S	75306	32

# INDEX By Ordering Number

Ordering Number	Item Code	Page #	Ordering Number	Item Code	Page #	Ordering Number	Item Code	Page #	Ordering Number	Item Code	Page #
HV1200L	73180	32	HV750SS-S/S	75299	32	HXF1600M	73443	31	ICT6	74535	86
HV1200L-PCST	63956	33	HV900L	73178	32	HXF1600M-S/S	75283	31	ICT6	74535	90
HV1200L-PCST-S/S	63998	33	HV900L-PCST	63948	33	HXF2-L	75982	34	ICT6	74535	93
HV1200L-S/S	75313	32	HV900L-PCST-S/S	63990	33	HXF2-M	75981	34	IEA42-60D	76937	150
HV1200M	73038	32	HV900L-S/S	75305	32	HXF2-S	75980	34	IEA72-96D	76938	150
HV1200M-PCST	63955	33	HV900M	73175	32	HXF2-SS	75979	34	IMK	76936	147
HV1200M-PCST-S/S	63997	33	HV900M-PCST	63947	33	HXF450M	74660	31	IMK	76936	148
HV1200M-S/S	75312	32	HV900M-PCST-S/S	63989	33	HXF450M-S/S	75267	31	IMK	76936	149
HV1200S	73058	32	HV900M-S/S	75304	32	HXF450S	74659	31	ISABK	76935	150
HV1200S-PCST	63954	33	HV900S	73034	32	HXF450S-S/S	75266	31	ISABK-LMH	77529	147
HV1200S-PCST-S/S	63996	33	HV900S-PCST	63946	33	HXF600M	74662	31	ISABK-LMH	77529	148
HV1200S-S/S	75311	32	HV900S-PCST-S/S	63988	33	HXF600M-S/S	75269	31	ISABK-LMH	77529	149
HV1200SS	73059	32	HV900S-S/S	75303	32	HXF600S	74661	31	LS-BP	77114	12
HV1200SS-PCST	63953	33	HV900SS	73055	33	HXF600S-S/S	75268	31	LS-BP-S/S	77115	12
HV1200SS-PCST-S/S	63995	33	HV900SS-PCST	63945	33	HXF750M	74664	31	LS-SP	77365	12
HV1200SS-S/S	75310	32	HV900SS-PCST-S/S	63987	33	HXF750M-S/S	75271	31	LS-SS	77118	12
HV1500L	73158	32	HV900SS-S/S	75302	32	HXF750S	74663	31	LS-SW	77117	12
HV1500L-PCST	63958	33	HVC-S/S	73494	37	HXF750S-S/S	75270	31	LS-SW-S/S	78850	12
HV1500L-PCST-S/S	64000	33	HVHD1800L	74477	32	HXF8L	74691	34	LSP12	77070	12
HV1500L-S/S	75315	32	HVHD1800L-PCST-S/S	64006	33	HXF8L-Blue	77521	34	LSP12-S/S	77079	12
HV1500LL	73215	32	HVHD1800L-S/S	A1595	32	HXF8M	74690	34	LSP18	77071	12
HV1500LL-PCST	63959	33	HVHD1800LL	74478	32	HXF8M-Blue	77520	34	LSP18-S/S	77080	12
HV1500LL-PCST-S/S	64001	33	HVHD1800LL-PCST-S/S	64007	33	HXF8S	74689	34	LSP24	77072	12
HV1500LL-S/S	75316	32	HVHD1800LL-S/S	A1596	32	HXF8S-Blue	77519	34	LSP24-S/S	77081	12
HV1500M	73177	32	HVHD1800M	74602	32	HXF8SS	74307	34	LSP30	77073	12
HV1500M-PCST	63957	33	HVHD1800M-PCST-S/S	64005	33	HXF8S-Blue	77518	34	LSP30-S/S	77082	12
HV1500M-PCST-S/S	63999	33	HVHD1800M-S/S	A1594	32	HXF900L	74667	31	LSP36	77074	12
HV1500M-S/S	75314	32	HVHD2100L	74540	32	HXF900L-S/S	75274	31	LSP36-S/S	77083	12
HV1600L	73638	32	HVHD2100L-PCST-S/S	64009	33	HXF900M	74666	31	LSP42	77075	12
HV1600L-PCST	63961	33	HVHD2100L-S/S	A1598	32	HXF900M-S/S	75273	31	LSP42-S/S	77084	12
HV1600L-PCST-S/S	64003	33	HVHD2100LL	74541	32	HXF900S	74665	31	LSP48	77076	12
HV1600L-S/S	75318	32	HVHD2100LL-PCST-S/S	64010	33	HXF900S-S/S	75272	31	LSP48-S/S	77085	12
HV1600LL	73639	32	HVHD2100LL-S/S	A1599	32	HXFHD1800L	74682	31	LSP54	77077	12
HV1600LL-PCST	63962	33	HVHD2100M	74539	32	HXFHD1800L-S/S	A1589	31	LSP54-S/S	77086	12
HV1600LL-PCST-S/S	64004	33	HVHD2100M-PCST-S/S	64008	33	HXFHD1800M	74681	31	LSP60	77078	12
HV1600LL-S/S	75319	32	HVHD2100M-S/S	A1597	32	HXFHD1800M-S/S	A1588	31	LSP60-S/S	77087	12
HV1600M	73637	32	HVHD2400L	74545	32	HXFHD2100L	74684	31	LST-B-S/S	77124	12
HV1600M-PCST	63960	33	HVHD2400L-PCST-S/S	64012	33	HXFHD2100L-S/S	A1591	31	LST-P	77121	12
HV1600M-PCST-S/S	64002	33	HVHD2400L-S/S	A1601	32	HXFHD2100M	74683	31	LST-S	77123	12
HV1600M-S/S	75317	32	HVHD2400LL	74546	32	HXFHD2100M-S/S	A1590	31	LST-TAK	77120	12
HV1800L-PCST	63964	33	HVHD2400LL-PCST-S/S	64013	33	HXFHD2400L	74686	31	LST-TAK	77120	12
HV1800L-PCST	63965	33	HVHD2400LL-S/S	A1602	32	HXFHD2400L-S/S	A1593	31	LST-W	77122	12
HV1800M-PCST	63963	33	HVHD2400M	74544	32	HXFHD2400M	74685	31	LST-W-S/S	77125	12
HV2100L-PCST	63967	33	HVHD2400M-PCST-S/S	64011	33	HXFHD2400M-S/S	A1592	31	LST-W-S/S-2	77126	12
HV2100L-PCST	63968	33	HVHD2400M-S/S	A1600	32	IB4	76926	139	LSTMPK	77366	12
HV2100M-PCST	63966	33	HVPT-S/S	73631	34	IB4	76926	141	LSTMPK-S/S	78933	12
HV2400L-PCST	63970	33	HVPT-S/S	73631	37	IB4	76926	144	LSTMPK2-S/S	78462	12
HV2400L-PCST	63971	33	HVPT-S/S	73631	40	IB4	76926	147	LSTPB-RK	77367	12
HV2400M-PCST	63969	33	HVPT-S/S	73631	41	IB4	76926	148	LSTPB-RK	77367	12
HV450M	73019	32	HVPT-S/S	73631	42	IB4	76926	149	MAK	74918	170
HV450M-PCST	63938	33	HVPT-S/S	73631	45	IB4-1U	76965	151	MAK-S/S	64926	170
HV450M-PCST-S/S	63980	33	HVPT-S/S	73631	46	IB5	76927	139	MAKHD	74919	170
HV450M-S/S	75295	32	HVPT-S/S	73631	47	IB5	76927	141	MAKHD	74919	170
HV450S	73028	32	HVT8-EL15-S/S	62254	34	IB5	76927	144	MAPEK	76024	123
HV450S-PCST	63937	33	HVT8-EL15-S/S	62254	46	IB5	76927	147	MBADB	79527	116
HV450S-PCST-S/S	63979	33	HVT8-EL15-S/S	62254	47	IB5	76927	148	MBC-18	79494	115
HV450S-S/S	75294	32	HVT8-S/S	75419	34	IB5	76927	149	MBC-24	79495	115
HV450SS	73026	32	HVT8-S/S	75419	37	IB5	76927	150	MBC-30	79496	115
HV450SS-PCST	63936	33	HVT8-S/S	75419	40	IB5-1U	76966	151	MBC-36	79497	115
HV450SS-PCST-S/S	63978	33	HVT8-S/S	75419	41	IBBK	76928	147	MBC-42	79498	115
HV450SS-S/S	75293	32	HVT8-S/S	75419	42	IBBK	76928	148	MBC-48	79499	115
HV600M	73173	32	HVT8-S/S	75419	45	IBBK	76928	149	MBC-54	79500	115
HV600M-PCST	63941	33	HVT8-S/S	75419	46	IBBK	76928	150	MBC-60	79501	115
HV600M-PCST-S/S	63983	33	HVT8-S/S	75419	47	IBS-DH5	76934	149	MBC-72	79502	115
HV600M-S/S	75298	32	HW-BC	74100	122	IBS-DH5	76934	150	MBC-84	79503	115
HV600S	73030	32	HW-IMPB	76939	151	IBS-H4	76933	149	MBCB	79526	116
HV600S-PCST	63940	33	HXF1050L	74670	31	IBS-L4	76929	147	MBCBC	79525	116
HV600S-PCST-S/S	63982	33	HXF1050L-S/S	75277	31	IBS-L5	76930	147	MBCBL	79532	116
HV600S-S/S	75297	32	HXF1050M	74669	31	IBS-M1200	82397	144	MBCBM	79528	116
HV600SS	73045	32	HXF1050M-S/S	75276	31	IBS-M1500	82398	144	MBCDBK	79536	115
HV600SS-PCST	63939	33	HXF1050S	74668	31	IBS-M4	76931	148	MBCDBK	79536	116
HV600SS-PCST-S/S	63981	33	HXF1050S-S/S	75275	31	IBS-M5	76932	148	MBCEC	79534	116
HV600SS-S/S	75296	32	HXF1200L	74673	31	ICT6	74535	59	MBCM-1	79529	116
HV750M	73174	32	HXF1200L-S/S	75280	31	ICT6	74535	61	MBCM-2	79530	116
HV750M-PCST	63944	33	HXF1200M	74672	31	ICT6	74535	62	MBCM	79524	116
HV750M-PCST-S/S	63986	33	HXF1200M-S/S	75279	31	ICT6	74535	64	MBCMCK	79533	116
HV750M-S/S	75301	32	HXF1200S	74671	31	ICT6	74535	66	MBCTA	79531	116
HV750S	73032	32	HXF1200S-S/S	75278	31	ICT6	74535	68	MBDS-18	79504	116
HV750S-PCST	63943	33	HXF1500L	74678	31	ICT6	74535	70	MBDS-24	79505	116
HV750S-PCST-S/S	63985	33	HXF1500L-S/S	75282	31	ICT6	74535	74	MBDS-30	79506	116
HV750S-S/S	75300	32	HXF1500M	74677	31	ICT6	74535	77	MBDS-36	79507	116
HV750SS	73053	32	HXF1500M-S/S	75281	31	ICT6	74535	79	MBDS-42	79508	116
HV750SS-PCST	63942	33	HXF1600L	73444	31	ICT6	74535	81	MBDS-48	79509	116
HV750SS-PCST-S/S	63984	33	HXF1600L-S/S	75284	31	ICT6	74535	84	MBDS-54	79510	116

# INDEX By Ordering Number

Ordering Number	Item Code	Page #	Ordering Number	Item Code	Page #	Ordering Number	Item Code	Page #	Ordering Number	Item Code	Page #
MBDS-60	79511	116	MHCP-2BC72	76645	30	MHS-1350V-SAC	78167	88	MHS-900V-SAC	78164	88
MBDS-72	79512	116	MHCP-2BC84	76812	30	MHS-1350V-SAC-S/S	78542	88	MHS-900V-SAC-S/S	78539	88
MBDS-84	79513	116	MHCP-30A	75938	28	MHS-1500-MST	64026	65	MHS-CARK-V24/600	77937	89
MBRD-18	79514	115	MHCP-30S	75930	28	MHS-1500-MST-S/S	64036	65	MHS-CARK-V24/600	77937	96
MBRD-18	79514	116	MHCP-36A	75939	28	MHS-1500BT	77486	67	MHS-CARK-V24/600-S/S MVECK/S/S	82841	89
MBRD-24	79515	115	MHCP-36S	75931	28	MHS-1500BTV-2SAC	78015	95	MHS-CARK-V24/600-S/S MVECK/S/S	82841	96
MBRD-24	79515	116	MHCP-42A	75940	28	MHS-1500BTV-2SAC-S/S	78324	95	MHS-CARK-V30/750	77938	89
MBRD-30	79516	115	MHCP-42S	75932	28	MHS-1500BTV-S/S	77495	67	MHS-CARK-V30/750	77938	96
MBRD-30	79516	116	MHCP-48A	75941	28	MHS-1500BTV-SAC	78013	95	MHS-CARK-V30/750-S/S MVECK/S/S	82842	89
MBRD-36	79517	115	MHCP-48S	75933	28	MHS-1500BTV-SAC-S/S	78322	95	MHS-CARK-V30/750-S/S MVECK/S/S	82842	96
MBRD-36	79517	116	MHCP-54A	75942	28	MHS-1500FPV	77795	69	MHS-CARK-V36/900	77939	89
MBRD-42	79518	115	MHCP-54S	75934	28	MHS-1500FPV-S/S	77805	69	MHS-CARK-V36/900	77939	96
MBRD-42	79518	116	MHCP-60A	75943	28	MHS-1500V-2SAC	78170	88	MHS-CARK-V36/900-S/S MVECK/S/S	82843	89
MBRD-48	79519	115	MHCP-60S	75935	28	MHS-1500V-2SAC-S/S	78545	88	MHS-CARK-V36/900-S/S MVECK/S/S	82843	96
MBRD-48	79519	116	MHCP-72A	75944	28	MHS-1500V-SAC	78168	88	MHS-CARK-V42/1050	77940	89
MBRD-54	79520	115	MHCP-72S	75936	28	MHS-1500V-SAC-S/S	78543	88	MHS-CARK-V42/1050	77940	96
MBRD-54	79520	116	MHCP-84A	76801	28	MHS-1800-MST	64027	65	MHS-CARK-V42/1050-S/S MVECK/S/S	82844	89
MBRD-60	79521	115	MHCP-84S	76800	28	MHS-1800-MST-S/S	64037	65	MHS-CARK-V42/1050-S/S MVECK/S/S	82844	96
MBRD-60	79521	116	MHCP-BS	76394	30	MHS-1800BT	77487	67	MHS-CARK-V48/1200	77941	89
MBRD-72	79522	115	MHCP-CH	76393	30	MHS-1800BTV-2SAC	78016	95	MHS-CARK-V48/1200	77941	96
MBRD-72	79522	116	MHP-6108	90151	26	MHS-1800BTV-2SAC-S/S	78325	95	MHS-CARK-V48/1200-S/S MVECK/S/S	82845	89
MBRD-84	79523	115	MHP-6120	90152	26	MHS-1800BTV-S/S	77496	67	MHS-CARK-V48/1200-S/S MVECK/S/S	82845	96
MBRD-84	79523	116	MHP-624	77703	26	MHS-1800BTV-SAC	78014	95	MHS-CARK-V54/1350	77942	89
MCB	74925	170	MHP-630	77704	26	MHS-1800BTV-SAC-S/S	78323	95	MHS-CARK-V54/1350	77942	96
MCB	74925	170	MHP-636	77705	26	MHS-1800FPV	77796	69	MHS-CARK-V54/1350-S/S MVECK/S/S	82846	89
MCB	74925	172	MHP-642	77706	26	MHS-1800FPV-S/S	77806	69	MHS-CARK-V54/1350-S/S MVECK/S/S	82846	96
MCBK	76025	170	MHP-648	77707	26	MHS-1800V-2SAC	78171	88	MHS-CARK-V60/1500	77943	89
MCBK	76025	170	MHP-654	77708	26	MHS-1800V-2SAC-S/S	78546	88	MHS-CARK-V60/1500	77943	96
MCBK	76025	172	MHP-660	77709	26	MHS-1800V-SAC	78169	88	MHS-CARK-V60/1500-S/S MVECK/S/S	82847	89
MCBKHD	76026	170	MHP-672	77710	26	MHS-1800V-SAC-S/S	78544	88	MHS-CARK-V60/1500-S/S MVECK/S/S	82847	96
MCBKHD	76026	170	MHP-684	77711	26	MHS-1950BT-2SAC-S/S	66255	95	MHS-CARK-V72/1800	77944	89
MCBKHD	76026	172	MHP-696	77712	26	MHS-1950V-2SAC-S/S	78649	88	MHS-CARK-V72/1800	77944	96
MCRK	74923	170	MHP-CP1050	75964	30	MHS-2100-MST	64028	65	MHS-CARK-V72/1800-S/S MVECK/S/S	82848	89
MCRK	74923	170	MHP-CP1200	75965	30	MHS-2100-MST-S/S	64038	65	MHS-CARK-V72/1800-S/S MVECK/S/S	82848	96
MCRK	74923	172	MHP-CP1400	75966	30	MHS-2100BT	77488	67	MHS-CARK2-V120/3000	77954	89
MCS	74930	170	MHP-CP1500	75967	30	MHS-2100BTV-2SAC	78017	95	MHS-CARK2-V120/3000	77954	96
MCS	74930	170	MHP-CP1800	75968	30	MHS-2100BTV-2SAC-S/S	78326	95	MHS-CARK2-V120/3000-S/S MV2CK/S	82853	89
MCS	74930	172	MHP-CP2100	76811	30	MHS-2100BTV-S/S	77497	67	MHS-CARK2-V120/3000-S/S MV2CK/S	82853	96
MCSHD	74931	170	MHP-CP600	75961	30	MHS-2100FPV	77797	69	MHS-CARK2-V60/1500	77950	89
MCSHD	74931	170	MHP-CP750	75962	30	MHS-2100FPV-S/S	77807	69	MHS-CARK2-V60/1500	77950	96
MCSHD	74931	172	MHP-CP900	75963	30	MHS-2100V-2SAC	78172	88	MHS-CARK2-V60/1500-S/S MV2CK/S	82849	89
MCSK	74927	170	MHP-EP	76392	24	MHS-2100V-2SAC-S/S	78547	88	MHS-CARK2-V60/1500-S/S MV2CK/S	82849	96
MCSK	74927	170	MHP-EP	76392	30	MHS-2400-MST	64029	65	MHS-CARK2-V72/1800	77951	89
MCSK	74927	172	MHP-EP	76392	42	MHS-2400-MST-S/S	64039	65	MHS-CARK2-V72/1800	77951	96
MCSKHD	74928	170	MHP-EP	76392	47	MHS-2400BT	77489	67	MHS-CARK2-V72/1800-S/S MV2CK/S	82850	89
MCSKHD	74928	170	MHP-EP	76392	76	MHS-2400BTV-2SAC	78018	95	MHS-CARK2-V72/1800-S/S MV2CK/S	82850	96
MCSKHD	74928	172	MHP-EP	76392	83	MHS-2400BTV-2SAC-S/S	78327	95	MHS-CARK2-V84/2100	77952	89
MDWS-1050-S/S	67469	108	MHP-EP	76392	90	MHS-2400BTV-S/S	77498	67	MHS-CARK2-V84/2100	77952	96
MDWS-1200-S/S	67470	108	MHP-EP	76392	97	MHS-2400FPV	77798	69	MHS-CARK2-V84/2100-S/S MV2CK/S	82851	89
MDWS-1350-S/S	67471	108	MHP-EP-S/S	77599	24	MHS-2400FPV-S/S	77808	69	MHS-CARK2-V84/2100-S/S MV2CK/S	82851	96
MDWS-1500-S/S	67472	108	MHP-EP-S/S	77599	42	MHS-2400V-2SAC	78173	88	MHS-CARK2-V96/2400	77953	89
MDWS-1800-S/S	67473	108	MHP-EP-S/S	77599	47	MHS-2400V-2SAC-S/S	78548	88	MHS-CARK2-V96/2400	77953	96
MDWS-2100-S/S	67474	108	MHP-EP-S/S	77599	78	MHS-3000BTV-2SAC	78019	95	MHS-CARK2-V96/2400-S/S MV2CK/S	82852	89
MDWS-24	75868	108	MHP-EP-S/S	77599	85	MHS-3000BTV-2SAC-S/S	78328	95	MHS-CARK2-V96/2400-S/S MV2CK/S	82852	96
MDWS-2400-S/S	67475	108	MHP-EP-S/S	77599	92	MHS-3000V-2SAC	78174	88	MHS-P1050	77502	66
MDWS-30	75869	108	MHP-EP-S/S	77599	98	MHS-3000V-2SAC-S/S	78549	88	MHS-P1050	77502	68
MDWS-36	75870	108	MHS-1050-MST	64023	65	MHS-600-MST	64020	65	MHS-P1050*	77502	64
MDWS-42	75871	108	MHS-1050-MST-S/S	64033	65	MHS-600-MST-S/S	64030	65	MHS-P1050*	77502	70
MDWS-48	75872	108	MHS-1050BT	77484	67	MHS-600BT	77481	67	MHS-P1050/S	77511	66
MDWS-54	75873	108	MHS-1050BTV-S/S	77493	67	MHS-600BTV-S/S	77490	67	MHS-P1050/S	77511	68
MDWS-60	75874	108	MHS-1050BTV-SAC	78010	95	MHS-600BTV-SAC	78007	95	MHS-P1050/S*	77511	64
MDWS-600-S/S	67466	108	MHS-1050BTV-SAC-S/S	78319	95	MHS-600BTV-SAC-S/S	78316	95	MHS-P1050/S*	77511	70
MDWS-72	75875	108	MHS-1050FPV	77792	69	MHS-600FPV	77789	69	MHS-P1200	77527	66
MDWS-750-S/S	67467	108	MHS-1050FPV-S/S	77802	69	MHS-600FPV-S/S	77799	69	MHS-P1200	77527	68
MDWS-84	76806	108	MHS-1050V-SAC	78165	88	MHS-600V-SAC	78162	88	MHS-P1200*	77527	64
MDWS-900-S/S	67468	108	MHS-1050V-SAC-S/S	78540	88	MHS-600V-SAC-S/S	78537	88	MHS-P1200*	77527	70
MDWS-96	79063	108	MHS-1200-MST	64024	65	MHS-750-MST	64021	65	MHS-P1200/S	77528	66
MESBK-PS	82364	104	MHS-1200-MST-S/S	64034	65	MHS-750-MST-S/S	64031	65	MHS-P1200/S	77528	68
MESBK-PS	82364	105	MHS-1200BT	77525	67	MHS-750BT	77482	67	MHS-P1200/S*	77528	64
MESPBL	87895	104	MHS-1200BTV-S/S	77526	67	MHS-750BTV-S/S	77491	67	MHS-P1200/S*	77528	70
MESPBL-SS	82892	105	MHS-1200BTV-SAC	78011	95	MHS-750BTV-SAC	78008	95	MHS-P1350	77503	66
MESPKR	81896	104	MHS-1200BTV-SAC-S/S	78320	95	MHS-750BTV-SAC-S/S	78317	95	MHS-P1350	77503	68
MESPKR-SS	82894	105	MHS-1200FPV	77793	69	MHS-750FPV	77790	69	MHS-P1350*	77503	64
MFASK	75531	170	MHS-1200FPV-S/S	77803	69	MHS-750FPV-S/S	77800	69	MHS-P1350*	77503	70
MFASK	75531	170	MHS-1200V-SAC	78166	88	MHS-750V-SAC	78163	88	MHS-P1350/S	77512	66
MHCP-24A	75937	28	MHS-1200V-SAC-S/S	78541	88	MHS-750V-SAC-S/S	78538	88	MHS-P1350/S	77512	68
MHCP-24S	75929	28	MHS-1350-MST	64025	65	MHS-900-MST	64022	65	MHS-P1350/S*	77512	64
MHCP-2BC24	76638	30	MHS-1350-MST-S/S	64035	65	MHS-900-MST-S/S	64032	65	MHS-P1350/S*	77512	70
MHCP-2BC30	76639	30	MHS-1350BT	77485	67	MHS-900BT	77483	67	MHS-P1500	77504	66
MHCP-2BC36	76640	30	MHS-1350BTV-S/S	77494	67	MHS-900BTV-S/S	77492	67	MHS-P1500	77504	68
MHCP-2BC42	76641	30	MHS-1350BTV-SAC	78012	95	MHS-900BTV-SAC	78009	95	MHS-P1500*	77504	64
MHCP-2BC48	76642	30	MHS-1350BTV-SAC-S/S	78321	95	MHS-900BTV-SAC-S/S	78318	95	MHS-P1500*	77504	70
MHCP-2BC54	76643	30	MHS-1350FPV	77794	69	MHS-900FPV	77791	69	MHS-P1500/S	77513	66
MHCP-2BC60	76644	30	MHS-1350FPV-S/S	77804	69	MHS-900FPV-S/S	77801	69	MHS-P1500/S	77513	68

# INDEX By Ordering Number

Ordering Number	Item Code	Page #	Ordering Number	Item Code	Page #	Ordering Number	Item Code	Page #	Ordering Number	Item Code	Page #
MHS-P1500S/S*	77513	64	MMPCP72	76465	24	MSTHD-G-S/S	90184	64	MXDPH-72/1800	106110	161
MHS-P1500S/S*	77513	70	MMPCP72-S/S	77597	24	MSTHD-S	79432	64	MXDPH-78/1950	106111	161
MHS-P1800	77505	66	MMPCP84	76808	24	MSTHD-S	79432	66	MXDPH-84/2100	106112	161
MHS-P1800	77505	68	MMPCP84-S/S	77598	24	MSTHD-S	79432	71	MXDPH-96/2400	106113	161
MHS-P1800*	77505	64	MORK	74921	170	MSTHD-S-S/S	90182	57	N6D3T-24-9-A45	83715	137
MHS-P1800*	77505	70	MORK	74921	170	MSTHD-S-S/S	90182	64	N6D3T-30-11-A45	83716	137
MHS-P1800S/S	77514	66	MPSTA-S/S	82289	105	MSTHD-SS-B	90183	66	N6D3T-36-13-A45	83717	137
MHS-P1800S/S	77514	68	MQMTSBK-SS	82895	105	MSTHD-SS-B	90183	71	N6D3T-42-15-A45	83718	137
MHS-P1800S/S*	77514	64	MR-1050PG	A2840	132	MSTHD-SS-G	90184	66	N6D3T-48-17-A45	83719	137
MHS-P1800S/S*	77514	70	MR-1200PG	A2841	132	MSTHD-SS-G	90184	71	N6D3T-54-19-A45	83720	137
MHS-P2100	77506	66	MR-1500PG	A2829	132	MSTHD-SS-S	90182	66	N6D3T-60-21-A45	83721	137
MHS-P2100	77506	68	MR-1600PG	A2830	132	MSTHD-SS-S	90182	71	N6D3T-72-25-A45	83722	137
MHS-P2100*	77506	70	MR-1800PG	A2831	132	MSTHD-SS-W	90181	66	Ni6D3T-24-9-A45	26184	139
MHS-P2100S/S	77515	66	MR-2100PG	A2832	132	MSTHD-SS-W	90181	71	Ni6D3T-30-11-A45	26185	139
MHS-P2100S/S	77515	68	MR-2400PG	A2833	132	MSTHD-W	79431	64	Ni6D3T-36-13-A45	26186	139
MHS-P2100S/S*	77515	70	MR-2600PG	A2834	132	MSTHD-W	79431	66	Ni6D3T-42-15-A45	26187	139
MHS-P2400	77507	66	MR-3000PG	A2835	132	MSTHD-W	79431	71	Ni6D3T-48-17-A45	26188	139
MHS-P2400	77507	68	MR-450PG	A2836	132	MSTHD-W-S/S	90181	64	Ni6D3T-54-19-A45	26189	139
MHS-P2400*	77507	70	MR-600PG	A2837	132	MSTLP	64930	64	Ni6D3T-60-21-A45	26190	139
MHS-P2400S/S	77516	66	MR-750PG	A2838	132	MSTLP	64930	64	Ni6D3T-72-25-A45	26191	139
MHS-P2400S/S	77516	68	MR-900PG	A2839	132	MSTLP	64930	66	OIBBK	76950	151
MHS-P2400S/S*	77516	70	MRB102	77545	27	MSTLP	64930	66	P-CARK-V24/600	78080	75
MHS-P600	77499	66	MRB108	77546	27	MUPS BK	82896	104	P-CARK-V24/600-S/S PVECKS/S	82815	75
MHS-P600	77499	68	MRB114	77547	27	MUPS BK-SS	82893	105	P-CARK-V30/750	78081	75
MHS-P600*	77499	64	MRB18	77531	27	MXCP-SCK	106624	161	P-CARK-V30/750-S/S PVECKS/S	82816	75
MHS-P600*	77499	70	MRB24	77532	27	MXDP-108/2700	106071	160	P-CARK-V36/900	78082	75
MHS-P600S/S	77508	66	MRB30	77533	27	MXDP-108/2700-H	106273	160	P-CARK-V36/900-S/S PVECKS/S	82817	75
MHS-P600S/S	77508	68	MRB36	77534	27	MXDP-120/3000	106072	160	P-CARK-V42/1050	78083	75
MHS-P600S/S*	77508	64	MRB42	77535	27	MXDP-120/3000-H	106274	160	P-CARK-V42/1050-S/S PVECKS/S	82818	75
MHS-P600S/S*	77508	70	MRB48	77536	27	MXDP-48/1200	106063	160	P-CARK-V48/1200	78084	75
MHS-P750	77500	66	MRB54	77537	27	MXDP-48/1200-H	106265	160	P-CARK-V48/1200-S/S PVECKS/S	82819	75
MHS-P750	77500	68	MRB60	77538	27	MXDP-60/1500	106064	160	P-CARK-V54/1350	78085	75
MHS-P750*	77500	64	MRB66	77539	27	MXDP-54/1350-H	106266	160	P-CARK-V54/1350-S/S PVECKS/S	82820	75
MHS-P750*	77500	70	MRB72	77540	27	MXDP-60/1500	106065	160	P-CARK-V60/1500	78086	75
MHS-P750S/S	77509	66	MRB78	77541	27	MXDP-60/1500-H	106267	160	P-CARK-V60/1500-S/S PVECKS/S	82821	75
MHS-P750S/S	77509	68	MRB84	77542	27	MXDP-66/1650	106066	160	P-CARK-V72/1800	78087	75
MHS-P750S/S*	77509	64	MRB90	77543	27	MXDP-66/1650-H	106268	160	P-CARK-V72/1800-S/S PVECKS/S	82822	75
MHS-P750S/S*	77509	70	MRB96	77544	27	MXDP-72/1800	106067	160	P-CARK-V78/1950/3000	78097	75
MHS-P900	77501	66	MSPBP	107852	110	MXDP-72/1800-H	106269	160	P-CARK2-V120/3000-S/S PV2ECKSS	82827	75
MHS-P900	77501	68	MSPBPK-S/S	77583	17	MXDP-78/1950	106068	160	P-CARK2-V60/1500	78093	75
MHS-P900*	77501	64	MSPMPK	75811	24	MXDP-78/1950-H	106270	160	P-CARK2-V60/1500-S/S PV2ECKSS	82823	75
MHS-P900*	77501	70	MSPMPK-S/S	77582	24	MXDP-84/2100	106069	160	P-CARK2-V72/1800	78094	75
MHS-P900S/S	77510	66	MSPPP30	75804	109	MXDP-84/2100-H	106271	160	P-CARK2-V72/1800-S/S PV2ECKSS	82824	75
MHS-P900S/S	77510	68	MSPPP30-S/S	77473	109	MXDP-96/2400	106070	160	P-CARK2-V78/1950-S/S PV2ECKSS	82826	75
MHS-P900S/S*	77510	64	MSPPP36	75805	109	MXDP-96/2400-H	106272	160	P-CARK2-V84/2100	78095	75
MHS-P900S/S*	77510	70	MSPPP36-S/S	77474	109	MXDP-MAK	106095	161	P-CARK2-V84/2100-S/S PV2ECKSS	82825	75
MMKU	77324	104	MSP42	75806	109	MXDP-MK	106549	161	P-CARK2-V96/2400	78096	75
MMKU-SS	77357	105	MSP42-S/S	77475	109	MXDP-MPK	106548	161	P-CARK2-V96/2400-S/S PV2ECKSS	82826	75
MMKUHD	77327	104	MSP48	75807	109	MXDPB-108/2700	106130	160	PAB	75513	51
MMKUHD-SS	77358	105	MSP48-S/S	77476	109	MXDPB-108/2700	106130	161	PAB	75513	55
MMP-624	76450	22	MSP54	75808	109	MXDPB-120/3000	106131	160	PAB	75513	59
MMP-624-S/S	77424	22	MSP54-S/S	77477	109	MXDPB-120/3000	106131	161	PAB	75513	61
MMP-630	76451	22	MSP60	75809	109	MXDPB-48/1200	106122	160	PAB	75513	68
MMP-630-S/S	77425	22	MSP60-S/S	77478	109	MXDPB-48/1200	106122	161	PAB	75513	77
MMP-636	76452	22	MSP66	76695	109	MXDPB-54/1350	106123	160	PAB	75513	84
MMP-636-S/S	77426	22	MSP66-S/S	77479	109	MXDPB-54/1350	106123	161	PAB	75513	97
MMP-642	76453	22	MSR	74914	168	MXDPB-60/1500	106124	160	PAB	75513	114
MMP-642-S/S	77427	22	MSR	74914	170	MXDPB-60/1500	106124	161	PAB	75513	117
MMP-648	76454	22	MSR	74914	172	MXDPB-66/1650	106125	160	PAB-S/S	75515	59
MMP-648-S/S	77428	22	MSR2	79378	170	MXDPB-66/1650	106125	161	PAB-S/S	75515	61
MMP-654	76455	22	MSR2-S/S	79378	169	MXDPB-72/1800	106126	160	PAB-S/S	75515	68
MMP-654-S/S	77429	22	MST-MBL	79436	71	MXDPB-72/1800	106126	161	PAB-S/S	75515	79
MMP-660	76456	22	MST-MBR	79437	71	MXDPB-78/1950	106127	160	PAB-S/S	75515	86
MMP-660-S/S	77430	22	MST-PMBLR	64564	71	MXDPB-78/1950	106127	161	PAB-S/S	75515	99
MMP-672	76457	22	MST-PMBLR-SS	64565	71	MXDPB-84/2100	106128	160	PAB-S/S	75515	114
MMP-672-S/S	77431	22	MSTAM	79435	64	MXDPB-84/2100	106128	161	PACB100	65803	71
MMP-684	76798	22	MSTAM	79435	66	MXDPB-96/2400	106129	160	PACB100	65803	91
MMP-684-S/S	77432	22	MSTAM-S/S	64931	64	MXDPB-96/2400	106129	161	PACB60	66055	71
MMPBPK	76466	24	MSTAM-S/S	64931	66	MXDPF-108/2700	106642	161	PACB60	66055	91
MMPBPK-S/S	77600	24	MSTBBK	63067	64	MXDPF-120/3000	106643	161	PAT1	65571	36
MMPCP24	76458	24	MSTBBK	63067	64	MXDPF-48/1200	106634	161	PAT1	65571	71
MMPCP24-S/S	77590	24	MSTBBK	63067	66	MXDPF-54/1350	106635	161	PAT1	65571	91
MMPCP30	76459	24	MSTBBK	63067	66	MXDPF-60/1500	106636	161	PATHK	78794	36
MMPCP30-S/S	77591	24	MSTDB	79434	71	MXDPF-66/1650	106637	161	PATLK	78791	36
MMPCP36	76460	24	MSTDB-S/S	65865	71	MXDPF-72/1800	106638	161	PBC-1	61356	134
MMPCP36-S/S	77592	24	MSTHD-B	79433	64	MXDPF-78/1950	106639	161	PBC-1-NC	108850	134
MMPCP42	76461	24	MSTHD-B	79433	66	MXDPF-84/2100	106640	161	PBC-2	61357	134
MMPCP42-S/S	77593	24	MSTHD-B	79433	71	MXDPF-96/2400	106641	161	PBC-2-NC	108851	134
MMPCP48	76462	24	MSTHD-B-S/S	90183	57	MXDPH-108/2700	106114	161	PBC-FR	61358	134
MMPCP48-S/S	77594	24	MSTHD-B-S/S	90183	64	MXDPH-120/3000	106115	161	PBC1 Case	U8393	134
MMPCP54	76463	24	MSTHD-G	63020	64	MXDPH-48/1200	106106	161	PBC2 Case	U8394	134
MMPCP54-S/S	77595	24	MSTHD-G	63020	66	MXDPH-54/1350	106107	161	PCAP-24/600	77913	77
MMPCP60	76464	24	MSTHD-G	63020	71	MXDPH-60/1500	106108	161	PCAP-24/600-S/S	78355	79
MMPCP60-S/S	77596	24	MSTHD-G-S/S	90184	57	MXDPH-66/1650	106109	161	PCAP-30/750	77914	77

# INDEX By Ordering Number

Ordering Number	Item Code	Page #	Ordering Number	Item Code	Page #	Ordering Number	Item Code	Page #	Ordering Number	Item Code	Page #
PCAP-30/750-S/S	78356	79	PPA1350	69481	128	PTK	65746	68	PTMA-1350-3	83664	171
PCAP-36/900	77915	77	PPA1500	69482	128	PTK	65746	68	PTMA-1600-1	83671	171
PCAP-36/900-S/S	78357	79	PPA1650	69483	128	PTK	65746	70	PTMA-1600-2	83677	171
PCAP-42/1050	77916	77	PPA1800	69484	128	PTK	65746	70	PTMA-1600-3	83665	171
PCAP-42/1050-S/S	78358	79	PPA1950	69485	128	PTM-1050-1		168	PTMA-1800-1	83672	171
PCAP-48/1200	77917	77	PPA2100	69486	128	PTM-1050-1-S/S		169	PTMA-1800-2	83678	171
PCAP-48/1200-S/S	78359	79	PPA2250	69487	128	PTM-1050-2		168	PTMA-1800-3	83666	171
PCAP-54/1350	77918	77	PPA2400	69488	128	PTM-1050-2-S/S		169	PTMA-750-1	83786	171
PCAP-54/1350-S/S	78360	79	PPHD1800	74597	59	PTM-1050-3		168	PTMA-750-2	83673	171
PCAP-60/1500	77919	77	PPHD1800-S/S	A1781	59	PTM-1050-3-S/S		169	PTMA-750-3	83785	171
PCAP-60/1500-S/S	78361	79	PPHD2000	74556	59	PTM-1200-1		168	PTMA-900-1	83667	171
PCAP-72/1800	77920	77	PPHD2000-S/S	A2120	59	PTM-1200-1-S/S		169	PTMA-900-3	83661	171
PCAP-72/1800-S/S	78362	79	PPHD2100	A2803	59	PTM-1200-2		168	PTMAAK	90194	172
PCB	75507	51	PPHD2100-S/S	A1613	59	PTM-1200-2-S/S		169	PTMAAKHD	90195	172
PFC-P-S/S	79289	59	PPHD2400	74557	59	PTM-1200-3		168	PTMAEKHDR	90192	172
PHA	73626	59	PPHD2400-S/S	A1775	59	PTM-1200-3-S/S		169	PTMAEKHDT	90191	172
PHA	73626	77	PPS6	73024	59	PTM-1350-1		168	PTMAEKHDVR	90193	172
PHDCB	75510	55	PS1050	73543	120	PTM-1350-1-S/S		169	PTMAEKR	90189	172
PHSC-S/S	73433	59	PS1050PL	73585	120	PTM-1350-2		168	PTMAEKT	90188	172
PHSC-S/S	73433	79	PS1200	73544	120	PTM-1350-2-S/S		169	PTMAEKVR	90190	172
PHSC-S/S	73433	120	PS1200PL	73586	120	PTM-1350-3		168	PTMAFMKHDR	90187	172
PMB	77727	30	PS1400	73546	120	PTM-1350-3-S/S		169	PTMAFMKR	90186	172
PMBL	75516	51	PS1400PL	73587	120	PTM-1500-1		168	PTMAFMKT	90185	172
PMBL	75516	55	PS1500	73545	120	PTM-1500-1-S/S		169	PTMAHD-1800-1	83737	171
PMBL	75516	59	PS1500PL	73588	120	PTM-1500-2		168	PTMAHD-1800-2	83740	171
PMBL	75516	61	PS1800	73537	120	PTM-1500-2-S/S		169	PTMAHD-1800-3	83734	171
PMBL	75516	68	PS1800PL	74049	120	PTM-1500-3		168	PTMAHD-2000-1	83738	171
PMBL	75516	77	PS2000	73539	120	PTM-1500-3-S/S		169	PTMAHD-2000-2	83741	171
PMBL	75516	84	PS2000 PL	74050	120	PTM-1600-1		168	PTMAHD-2000-3	83735	171
PMBL	75516	97	PS600	73014	120	PTM-1600-1-S/S		169	PTMAHD-2400-1	83739	171
PMBL	75516	114	PS600PL	73582	120	PTM-1600-2		168	PTMAHD-2400-2	83742	171
PMBL	75516	117	PS750	73541	120	PTM-1600-2-S/S		169	PTMAHD-2400-3	83736	171
PMBL-S/S	75518	59	PS750PL	73583	120	PTM-1600-3		168	PTMAORK	90197	172
PMBL-S/S	75518	61	PS900	73542	120	PTM-1600-3-S/S		169	PTPK	75897	30
PMBL-S/S	75518	68	PS900PL	73584	120	PTM-1800-1		168	PTPK-MT	82343	104
PMBL-S/S	75518	71	PSA150	73156	59	PTM-1800-1-S/S		169	PTPK-MT-S/S	82342	105
PMBL-S/S	75518	79	PSA150	73156	74	PTM-1800-2		168	PTS-18R	77664	165
PMBL-S/S	75518	86	PSA150	73156	77	PTM-1800-2-S/S		169	PTS-24R	77665	165
PMBL-S/S	75518	91	PSA150-EL15	62094	59	PTM-1800-3		168	PTS-30R	77666	165
PMBL-S/S	75518	99	PSA150-EL15	62094	77	PTM-1800-3-S/S		169	PTS-36R	77667	165
PMBL-S/S	75518	114	PSA150-XL	67777	59	PTM-2000-1		168	PTS-42R	77668	165
PMBR	75519	51	PSA150-XL	67777	77	PTM-2000-1-S/S		169	PTS-48R	77669	165
PMBR	75519	55	PSN11010	74053	120	PTM-2000-2		168	PTS-54R	77670	165
PMBR	75519	59	PSR-L-F	105631	162	PTM-2000-2-S/S		169	PTS-60R	77671	165
PMBR	75519	61	PSR-M-F	105630	162	PTM-2000-3		168	PTS-72R	77672	165
PMBR	75519	68	PSR-S-F	105629	162	PTM-2000-3-S/S		169	PTS-ABK	77693	166
PMBR	75519	77	PSR-XL-F	105632	162	PTM-2400-1		168	PTS-AHDSR	93090	166
PMBR	75519	84	PSSS	74773	59	PTM-2400-1-S/S		169	PTS-ASR	93089	166
PMBR	75519	97	PSSS-H	73222	120	PTM-2400-2		168	PTS-EBK	77702	166
PMBR	75519	114	PSSS-N	73221	120	PTM-2400-2-S/S		169	PTS-HDSR	77692	166
PMBR	75519	117	PST2-S	77724	30	PTM-2400-3		168	PTS-HIBK	77697	166
PMBR-S/S	75521	59	PST2-W	77723	30	PTM-2400-3-S/S		169	PTS-IBK	77696	166
PMBR-S/S	75521	61	PSTA	75896	24	PTM-2600-1		168	PTS-LHSAA	77756	166
PMBR-S/S	75521	68	PSTA	75896	30	PTM-2600-1-S/S		169	PTS-MBK	77700	166
PMBR-S/S	75521	71	PSTA-S/S	77442	24	PTM-2600-2		168	PTS-MBKUG	77701	166
PMBR-S/S	75521	79	PSTS-S	75899	30	PTM-2600-2-S/S		169	PTS-PA	77699	166
PMBR-S/S	75521	86	PSTS-S	75899	35	PTM-2600-3		168	PTS-PS	77698	166
PMBR-S/S	75521	91	PSTS-S-S/S	79056	35	PTM-2600-3-S/S		169	PTS-RHSAA	77755	166
PMBR-S/S	75521	99	PSTS-W	75898	24	PTM-3000-1		168	PTS-RR21	77680	165
PMBR-S/S	75521	114	PSTS-W	75898	30	PTM-3000-1-S/S		169	PTS-RR27	77681	165
PMR-CHB-L60	61073	132	PSTS-W	75898	104	PTM-3000-2		168	PTS-RR33	77682	165
PMR-CHB-L73	61075	132	PSVA	73434	120	PTM-3000-2-S/S		169	PTS-RR39	77683	165
PMR-CHB-R60	61074	132	PTEZ-1050	90269	164	PTM-3000-3		168	PTS-RR45	77684	165
PMR-CHB-R73	61076	132	PTEZ-1200	90270	164	PTM-3000-3-S/S		169	PTS-RR51	77685	165
PMSMK	74916	170	PTEZ-450	90265	164	PTM-750-1		168	PTS-RR57	77686	165
PMSMK-S/S	64925	170	PTEZ-600	90266	164	PTM-750-1-S/S		169	PTS-RR63	77687	165
PMSMK2	79380	172	PTEZ-750	90267	164	PTM-750-2		168	PTS-RR75	77689	165
PP1050	73011	59	PTEZ-900	90268	164	PTM-750-2-S/S		169	PTS-RR75	77694	166
PP1050-S/S	75386	59	PTEZHD-1050	90616	164	PTM-750-3		168	PTS-SAK	77694	166
PP1200	73013	59	PTEZHD-1200	90617	164	PTM-750-3-S/S		169	PTS-SR	77691	166
PP1200-S/S	75387	59	PTEZHD-1350	90618	164	PTM-900-1		168	PV1050	73010	58
PP1400	73015	59	PTEZHD-1400	90795	164	PTM-900-1-S/S		169	PV1050-S/S	75327	58
PP1400-S/S	75388	59	PTEZHD-1500	90619	164	PTM-900-2		168	PV1050-SAC	78023	74
PP1500	73016	59	PTEZHD-1600	90796	164	PTM-900-2-S/S		169	PV1050-SAC-S/S	78332	74
PP1500-S/S	75389	59	PTEZHD-1800	90620	164	PTM-900-3		168	PV1200	73012	58
PP450	73003	59	PTEZHD-2000	90797	164	PTM-900-3-S/S		169	PV1200-S/S	75328	58
PP450-S/S	75382	59	PTEZHD-2100	90621	164	PTMA-1050-1	83668	171	PV1200-SAC	78024	74
PP600	73005	59	PTEZHD-DCK	90805	164	PTMA-1050-2	83674	171	PV1200-SAC-S/S	78333	74
PP600-S/S	75383	59	PTEZHD-JBK	90807	164	PTMA-1050-3	83662	171	PV1350-SAC	78025	74
PP750	73007	59	PTEZHD-MBK	90803	164	PTMA-1200-1	83669	171	PV1350-SAC-S/S	78334	74
PP750-S/S	75384	59	PTEZHD-PBK	90804	164	PTMA-1200-2	83675	171	PV1400	73436	58
PP900	73009	59	PTEZHD-WRBK	90806	164	PTMA-1200-3	83663	171	PV1400-S/S	75329	58
PP900-S/S	75385	59	PTK	65746	66	PTMA-1350-1	83670	171	PV1500	73437	58
PPA1200	69480	128	PTK	65746	66	PTMA-1350-2	83676	171	PV1500-2SAC	78028	74
									PV1500-2SAC-S/S	78337	74



# INDEX By Ordering Number

Ordering Number	Item Code	Page #	Ordering Number	Item Code	Page #	Ordering Number	Item Code	Page #	Ordering Number	Item Code	Page #
PV1500-S/S	75330	58	R-CARK-V48/1200-S/S RVECKS/S	82832	82	RBVP-SD-S-2800	91781	157	RSA150-EL15	61141	62
PV1500-SAC	78026	74	R-CARK-V54/1350	78111	82	RBVP-SD-S-600	91769	157	RSA150-EL15	61141	64
PV1500-SAC-S/S	78335	74	R-CARK-V54/1350-S/S RVECKS/S	82833	82	RBVP-SD-S-750	91770	157	RSA150-EL15	61141	66
PV1800-2SAC	78029	74	R-CARK-V60/1500	78112	82	RBVP-SD-S-900	91771	157	RSA150-EL15	61141	68
PV1800-2SAC-S/S	78338	74	R-CARK-V60/1500-S/S RVECKS/S	82834	82	RC-HD-S/S	69521	61	RSA150-EL15	61141	70
PV1800-SAC	78027	74	R-CARK-V72/1800	78113	82	RC-HD-S/S	69521	84	RSA150-EL15	61141	84
PV1800-SAC-S/S	78336	74	R-CARK-V72/1800-S/S RVECKS/S	82835	82	RC-HD-S/S	69521	86	RSA150-EL15	61141	90
PV1950-2SAC-S/S	78556	74	R-CARK-V120/3000	78123	82	RC-S/S	76250	61	RSA150-EL15	61141	97
PV2100-2SAC	78030	74	R-CARK2-V120/3000-S/S RV2ECKSS	82840	82	RC-S/S	76250	86	RSA150-XL	67776	61
PV2100-2SAC-S/S	78339	74	R-CARK2-V60/1500	78119	82	RCAP-24/600	77921	84	RSA150-XL	67776	62
PV2400-2SAC	78031	74	R-CARK2-V60/1500-S/S RV2ECKSS	82836	82	RCAP-24/600-S/S	78363	86	RSA150-XL	67776	64
PV2400-2SAC-S/S	78340	74	R-CARK2-V72/1800	78120	82	RCAP-30/750	77922	84	RSA150-XL	67776	66
PV3000-2SAC	78032	74	R-CARK2-V72/1800-S/S RV2ECKSS	82837	82	RCAP-30/750-S/S	78364	86	RSA150-XL	67776	68
PV3000-2SAC-S/S	78341	74	R-CARK2-V84/2100	78121	82	RCAP-36/900	77923	84	RSA150-XL	67776	70
PV450	73435	58	R-CARK2-V84/2100-S/S RV2ECKSS	82838	82	RCAP-36/900-S/S	78365	86	RSA150-XL	67776	84
PV450-S/S	75323	58	R-CARK2-V96/2400	78122	82	RCAP-42/1050	77924	84	RSA150-XL	67776	90
PV600	73004	58	R-CARK2-V96/2400-S/S RV2ECKSS	82839	82	RCAP-42/1050-S/S	78366	86	RV1050	74637	60
PV600-S/S	75324	58	RBPCP	73162	163	RCAP-48/1200	77925	84	RV1050-S/S	75345	60
PV600-SAC	78020	74	RBPFK-L	105607	163	RCAP-48/1200-S/S	78367	86	RV1050-SAC	78036	81
PV600-SAC-S/S	78329	74	RBPFK-M	105606	163	RCAP-54/1350	77926	84	RV1050-SAC-S/S	78345	81
PV750	73006	58	RBPFK-S	105605	163	RCAP-54/1350-S/S	78368	86	RV1200	74638	60
PV750-S/S	75325	58	RBPFK-XL	105608	163	RCAP-60/1500	77927	84	RV1200-S/S	75346	60
PV750-SAC	78021	74	RBPMBK	105603	163	RCAP-60/1500-S/S	78369	86	RV1200-SAC	78037	81
PV750-SAC-S/S	78330	74	RBPRET	105613	163	RCAP-72/1800	77928	84	RV1200-SAC-S/S	78346	81
PV900	73008	58	RBPRET	73163	166	RCAP-72/1800-S/S	78370	86	RV1350-SAC	78038	81
PV900-S/S	75326	58	RBPRET-XL	105614	163	Reduce Adap F 3/4	61058	120	RV1350-SAC-S/S	78347	81
PV900-SAC	78022	74	RBPSR-L	105623	163	RIBBK	81250	137	RV1350-SAC-S/S	78347	81
PV900-SAC-S/S	78331	74	RBPSR-M	105622	163	RIBBK	81250	139	RV1400	74639	60
PVHD1800	74598	58	RBPSR-S	105621	163	RIBBK	81250	141	RV1400-S/S	75347	60
PVHD1800-S/S	A1603	58	RBPSR-XL	105624	163	RIBBK	81250	144	RV1500	74640	60
PVHD2000	75452	58	RBVP-HD-1050	68253	156	RMC-FS	76558	174	RV1500-2SAC	78041	81
PVHD2000-S/S	A2046	58	RBVP-HD-1200	68254	156	RMC1-BPP	76415	174	RV1500-2SAC-S/S	78350	81
PVHD2100	74553	58	RBVP-HD-1350	68255	156	RMC1-CB	75820	174	RV1500-S/S	75348	60
PVHD2100-S/S	A1604	58	RBVP-HD-1500	68256	156	RMC1-PP	75832	174	RV1500-SAC	78039	81
PVHD2400	74555	58	RBVP-HD-1600	68257	156	RMC2-AP-S/S	A2704	174	RV1500-SAC-S/S	78348	81
PVHD2400-S/S	A1605	58	RBVP-HD-1800	68258	156	RMC2-FSAPK	76559	174	RV1800-2SAC	78042	81
PVT6-S/S	75420	59	RBVP-HD-2000	68259	156	RP1050	74608	61	RV1800-2SAC-S/S	78351	81
PVT6-S/S	75420	79	RBVP-HD-2200	68260	156	RP1050-S/S	75404	61	RV1800-SAC	78040	81
PVT6-S/S	75420	120	RBVP-HD-2400	68261	156	RP1200	74609	61	RV1800-SAC-S/S	78349	81
QMT-G	76483	24	RBVP-HD-2500	68262	156	RP1200-S/S	75405	61	RV1950-2SAC-S/S	78663	81
QMT-G-S/S	77586	24	RBVP-HD-2600	68263	156	RP1400	74610	61	RV2100-SAC	78043	81
QMT-P	76074	24	RBVP-HD-2800	68264	156	RP1400-S/S	75406	61	RV2100-2SAC-S/S	78352	81
QMT-P-S/S	77584	24	RBVP-HD-3000	68265	156	RP1500	74611	61	RV2400-2SAC	78044	81
QMT-W	76075	24	RBVP-HD-3200	68266	156	RP1500-S/S	75407	61	RV2400-2SAC-S/S	78353	81
QMT-W-S/S	77585	24	RBVP-HD-900	68252	156	RP450	74604	61	RV3000-2SAC	78045	81
QMTBK-G	76540	24	RBVP-HD-N	91782	157	RP450-S/S	75400	61	RV3000-2SAC-S/S	78354	81
QMTBK-G	76540	24	RBVP-HD-S-1050	91784	157	RP600	74605	61	RV450	74633	60
QMTBK-GCN	82174	104	RBVP-HD-S-1200	91785	157	RP600-S/S	75401	61	RV450-S/S	75341	60
QMTBK-GCN	82174	105	RBVP-HD-S-1350	91786	157	RP750	74606	61	RV600	74634	60
QMTBK-P	76097	24	RBVP-HD-S-1500	91787	157	RP750-S/S	75402	61	RV600-S/S	75342	60
QMTBK-P	76097	24	RBVP-HD-S-1600	91788	157	RP900	74607	61	RV600-SAC	78033	81
QMTBK-W	76098	24	RBVP-HD-S-1800	91789	157	RP900-S/S	75403	61	RV600-SAC-S/S	78342	81
QMTBK-W	76098	24	RBVP-HD-S-2000	91790	157	RPA1200	103602	128	RV750	74635	60
QMTBK-W	76098	30	RBVP-HD-S-2200	91791	157	RPA1350	103603	128	RV750-S/S	75343	60
QMTBK-W-S-MT	82175	104	RBVP-HD-S-2400	91792	157	RPA1500	103604	128	RV750-SAC	78034	81
QMTBK-WS-MT	82175	105	RBVP-HD-S-2500	91793	157	RPA1800	103605	128	RV750-SAC-S/S	78343	81
QMTPAK	76096	24	RBVP-HD-S-2600	91794	157	RPA1950	103606	128	RV900	74636	60
QMTPAK-S/S	77587	24	RBVP-HD-S-2800	91795	157	RPA2100	103607	128	RV900-S/S	75344	60
QMTPSBK	76099	24	RBVP-HD-S-3000	91796	157	RPA2400	103608	128	RV900-SAC	78035	81
QMTPSBK-CN	82182	104	RBVP-HD-S-3200	91797	157	RPHD1800	74613	61	RV900-SAC-S/S	78344	81
QMTPSBK-S/S	77588	24	RBVP-HD-S-900	91783	157	RPHD1800-S/S	A1575	61	RVHD1800	74642	60
QMTS-G	76484	24	RBVP-SD-1050	68270	156	RPHD2000	74614	61	RVHD1800-S/S	A1626	60
QMTS-G	76484	104	RBVP-SD-1200	68271	156	RPHD2000-S/S	61270	61	RVHD2000	75463	60
QMTS-G-S/S	77452	17	RBVP-SD-1350	68272	156	RPHD2100	A2527	61	RVHD2100	74643	60
QMTS-G-S/S	77452	24	RBVP-SD-1500	68273	156	RPHD2100-S/S	A1629	61	RVHD2100-S/S	A1628	60
QMTS-G-SS	77452	105	RBVP-SD-1800	68274	156	RPHD2400	74615	61	RVHD2400	74644	60
QMTS-P	75845	16	RBVP-SD-2000	68275	156	RPHD2400-S/S	61271	61	RVHD2400-S/S	A1610	60
QMTS-P	75845	24	RBVP-SD-2200	68276	156	RSA	76249	61	RVT6-S/S	76205	61
QMTS-P	75845	104	RBVP-SD-2400	68277	156	RSA	76249	84	RVT6-S/S	76205	62
QMTS-P-S/S	77450	17	RBVP-SD-2600	68278	156	RSA-HD	69520	61	RVT6-S/S	76205	64
QMTS-P-S/S	77450	24	RBVP-SD-2800	68279	156	RSA-HD	69520	84	RVT6-S/S	76205	66
QMTS-P-SS	77450	105	RBVP-SD-600	68267	156	RSA-HD	69520	86	RVT6-S/S	76205	68
QMTS-W-S/S	77451	17	RBVP-SD-750	68268	156	RSA150	73628	61	RVT6-S/S	76205	70
QMTS-W-SS	77451	105	RBVP-SD-900	68269	156	RSA150	73628	62	RVT6-S/S	76205	86
QSTS-W-S/S	77451	24	RBVP-SD-N	91768	157	RSA150	73628	64	RVT6-S/S	76205	93
R-CARK-V24/600	78106	82	RBVP-SD-S-1050	91772	157	RSA150	73628	66	RVT6-S/S	76205	99
R-CARK-V24/600-S/S RVECKS/S	82828	82	RBVP-SD-S-1200	91773	157	RSA150	73628	68	SAC2-TIP-TL	77866	77
R-CARK-V30/750	78107	82	RBVP-SD-S-1350	91774	157	RSA150	73628	70	SAC2-TIP-TL	77866	79
R-CARK-V30/750-S/S RVECKS/S	82829	82	RBVP-SD-S-1500	91775	157	RSA150	73628	81	SAC2-TIP-TL	77866	84
R-CARK-V36/900	78108	82	RBVP-SD-S-1800	91776	157	RSA150	73628	84	SAC2-TIP-TL	77866	86
R-CARK-V36/900-S/S RVECKS/S	82830	82	RBVP-SD-S-2000	91777	157	RSA150	73628	90	SAC2-TIP-TL	77866	91
R-CARK-V42/1050	78109	82	RBVP-SD-S-2200	91778	157	RSA150	73628	95	SAC2-TIP-TL	77866	93
R-CARK-V42/1050-S/S RVECKS/S	82831	82	RBVP-SD-S-2400	91779	157	RSA150	73628	97	SAC2-TIP-TL	77866	97
R-CARK-V48/1200	78110	82	RBVP-SD-S-2600	91780	157	RSA150-EL15	61141	61	SAC2-TIP-TL	77866	99

# INDEX By Ordering Number

Ordering Number	Item Code	Page #	Ordering Number	Item Code	Page #	Ordering Number	Item Code	Page #	Ordering Number	Item Code	Page #
SACKRP	77885	41	SACPL2-60/1500	77895	97	SB1500-SEC	61069	119	SKPU-150x19x15.2	91223	175
SACKRP	77885	77	SACPL2-60/1500-S/S	78379	78	SB1500A	A1838	119	SKPU-150x20x7.6	90284	175
SACKRP	77885	84	SACPL2-60/1500-S/S	78379	85	SB1800	A0317	120	SKPU-150x25x15.2	91303	175
SACKRP	77885	91	SACPL2-60/1500-S/S	78379	92	SB1800-SEC	61070	119	SKPU-150x25x7.6	91300	175
SACKRP	77885	97	SACPL2-60/1500-S/S	78379	98	SB1800A	A1357	119	SKPU-200x10x15.2	91307	175
SACKRP-S/S	78399	79	SACPL2-72/1800	77896	76	SB2100	61287	120	SKPU-200x10x7.6	91304	175
SACKRP-S/S	78399	86	SACPL2-72/1800	77896	83	SB2400	A1776	120	SKPU-200x12x15.2	91224	175
SACKRP-S/S	78399	93	SACPL2-72/1800	77896	90	SB4	78789	137	SKPU-200x12x7.6	90285	175
SACKRP-S/S	78399	99	SACPL2-72/1800	77896	97	SB4	78789	139	SKPU-200x16x15.2	91308	175
SACPL-24/600	77887	76	SACPL2-72/1800-S/S	78380	78	SB4	78789	141	SKPU-200x16x7.6	91305	175
SACPL-24/600	77887	83	SACPL2-72/1800-S/S	78380	85	SB4	78789	144	SKPU-200x19x15.2	91225	175
SACPL-24/600	77887	90	SACPL2-72/1800-S/S	78380	92	SB4	78789	148	SKPU-200x20x7.6	90286	175
SACPL-24/600	77887	97	SACPL2-72/1800-S/S	78380	98	SB4	78789	149	SKPU-200x25x15.2	91309	175
SACPL-24/600-S/S	78371	78	SACPL2-78/1950-S/S	78642	78	SB5	78790	137	SKPU-200x25x7.6	91306	175
SACPL-24/600-S/S	78371	85	SACPL2-78/1950-S/S	78642	85	SB5	78790	139	SKPU-250x10x15.2	91315	175
SACPL-24/600-S/S	78371	92	SACPL2-78/1950-S/S	78642	92	SB5	78790	141	SKPU-250x10x7.6	91310	175
SACPL-24/600-S/S	78371	98	SACPL2-78/1950-S/S	78642	98	SB5	78790	144	SKPU-250x16x15.2	91316	175
SACPL-30/750	77888	76	SACPL2-84/2100	77897	76	SB5	78790	148	SKPU-250x12x7.6	91311	175
SACPL-30/750	77888	83	SACPL2-84/2100	77897	83	SB5	78790	149	SKPU-250x16x15.2	91317	175
SACPL-30/750	77888	90	SACPL2-84/2100	77897	90	SB5	78790	150	SKPU-250x16x7.6	91312	175
SACPL-30/750	77888	97	SACPL2-84/2100	77897	97	SB600	A0886	120	SKPU-250x19x15.2	91318	175
SACPL-30/750-S/S	78372	78	SACPL2-84/2100-S/S	78381	78	SB600-SEC	61063	119	SKPU-250x19x7.6	91313	175
SACPL-30/750-S/S	78372	85	SACPL2-84/2100-S/S	78381	85	SB600A	A0887	119	SKPU-250x25x15.2	91319	175
SACPL-30/750-S/S	78372	92	SACPL2-84/2100-S/S	78381	92	SB750	A0408	120	SKPU-250x25x7.6	91314	175
SACPL-30/750-S/S	78372	98	SACPL2-84/2100-S/S	78381	98	SB750-SEC	61064	119	SKPU-300x10x15.2	91325	175
SACPL-36/900	77889	76	SACPL2-96/2400	77898	76	SB750A	A0407	119	SKPU-300x10x7.6	91320	175
SACPL-36/900	77889	83	SACPL2-96/2400	77898	83	SB900	A0696	120	SKPU-300x12x15.2	91326	175
SACPL-36/900	77889	90	SACPL2-96/2400	77898	90	SB900-SEC	61065	119	SKPU-300x12x7.6	91321	175
SACPL-36/900	77889	97	SACPL2-96/2400	77898	97	SB900A	A0912	119	SKPU-300x16x15.2	91327	175
SACPL-36/900-S/S	78373	78	SACPL2-96/2400-S/S	78382	78	SCU60	82812	104	SKPU-300x16x7.6	91322	175
SACPL-36/900-S/S	78373	85	SACPL2-96/2400-S/S	78382	85	SCU60-S/S	82810	105	SKPU-300x19x15.2	91328	175
SACPL-36/900-S/S	78373	92	SACPL2-96/2400-S/S	78382	92	SCUHD	82813	104	SKPU-300x19x7.6	91323	175
SACPL-36/900-S/S	78373	98	SACPL2-96/2400-S/S	78382	98	SCUHD-S/S	82811	105	SKPU-300x25x15.2	91329	175
SACPL-42/1050	77890	76	SACRH	77883	41	SE5-T1000	83680	172	SKPU-300x25x7.6	91234	175
SACPL-42/1050	77890	83	SACRH	77883	77	SE5-T1200	83681	172	SKPU-DUAL-150x12x15.2	91404	174
SACPL-42/1050	77890	90	SACRH	77883	84	SE5-T1400/VR1000	83682	172	SKPU-DUAL-150x12x7.6	91400	174
SACPL-42/1050	77890	97	SACRH	77883	91	SE5-T1400/VR1000	83682	172	SKPU-DUAL-150x20x15.2	91405	174
SACPL-42/1050-S/S	78374	78	SACRH	77883	97	SE5-T1600	83683	172	SKPU-DUAL-150x20x7.6	91401	174
SACPL-42/1050-S/S	78374	85	SACRH-S/S	78397	79	SE5-T1800	83684	172	SKPU-DUAL-200x12x15.2	91406	174
SACPL-42/1050-S/S	78374	92	SACRH-S/S	78397	86	SE5-T800	83679	172	SKPU-DUAL-200x12x7.6	91402	174
SACPL-42/1050-S/S	78374	98	SACRH-S/S	78397	93	SE5-VR1200	83682	172	SKPU-DUAL-200x20x15.2	91407	174
SACPL-48/1200	77891	76	SACRH-S/S	78397	99	SE5-VR1400	83683	172	SKPU-DUAL-200x20x7.6	91403	174
SACPL-48/1200	77891	83	SACRHL	77884	41	SE5-VR1600	83694	172	SMR-CCB-L60	A2844	132
SACPL-48/1200	77891	90	SACRHL	77884	77	SE5-VR1800	83695	172	SMR-CCB-L73	A2842	77
SACPL-48/1200	77891	97	SACRHL	77884	84	SE5-VR800	83691	172	SMR-CCB-L73	A2842	84
SACPL-48/1200-S/S	78375	78	SACRHL	77884	91	SE6-R1000	83686	172	SMR-CCB-L73	A2842	97
SACPL-48/1200-S/S	78375	85	SACRHL	77884	97	SE6-R1200	83687	172	SMR-CCB-L73	A2842	132
SACPL-48/1200-S/S	78375	92	SACRHL-S/S	78398	79	SE6-R1400	83688	172	SMR-CCB-R60	A2845	132
SACPL-48/1200-S/S	78375	98	SACRHL-S/S	78398	86	SE6-R1600	83689	172	SMR-CCB-R73	A2843	77
SACPL-54/1350	77892	76	SACRHL-S/S	78398	93	SE6-R1800	83690	172	SMR-CCB-R73	A2843	84
SACPL-54/1350	77892	83	SACRHL-S/S	78398	99	SE6-R1800	83690	172	SMR-CCB-R73	A2843	97
SACPL-54/1350	77892	90	SACRKN	77882	41	SE6-R2000	83746	172	SMR-CCB-R73	A2843	132
SACPL-54/1350	77892	97	SACRKN	77882	77	SE6-R2200	83747	172	SPFC	79200	66
SACPL-54/1350-S/S	78376	78	SACRKN	77882	79	SE6-R800	83685	172	SPFC	79200	68
SACPL-54/1350-S/S	78376	85	SACRKN	77882	84	SE6-T1800	83743	172	SPFC	79200	70
SACPL-54/1350-S/S	78376	92	SACRKN	77882	86	SE6-T2000	83744	172	SPFC	79200	90
SACPL-54/1350-S/S	78376	98	SACRKN	77882	91	SE6-T2200/R650	83745	172	SPFC	79200	97
SACPL-60/1500	77893	76	SACRKN	77882	93	SE6-T2200/R650	83745	172	SPFC-S/S	79201	66
SACPL-60/1500	77893	83	SACRKN	77882	97	SE6-VR1800	83748	172	SPFC-S/S	79201	68
SACPL-60/1500	77893	90	SACRKN	77882	99	SE6-VR2000	83749	172	SPFC-S/S	79201	70
SACPL-60/1500	77893	97	SACRKT	77886	77	SE6-VR2200	83750	172	SPFC-S/S	79201	93
SACPL-60/1500-S/S	78377	78	SACRKT	77886	84	SHIM-KITH	77550	149	SPFC-S/S	79201	99
SACPL-60/1500-S/S	78377	85	SACRKT	77886	91	SHIM-KITL	77548	147	SPG-CVR-A	77387	21
SACPL-60/1500-S/S	78377	92	SACRKT	77886	97	SHIM-KITM	77549	148	SPG-CVR-A	77387	73
SACPL-60/1500-S/S	78377	98	SACRKT-S/S	78401	79	SHIM-LDKIT	82393	137	SPG-CVR-A	77387	101
SACPL-72/1800	77894	76	SACRKT-S/S	78401	86	SHIM-LDKIT	82393	139	SPG-CVR-B	77388	21
SACPL-72/1800	77894	83	SACRKT-S/S	78401	93	SHIM-LDKIT	82393	141	SPG-CVR-B	77388	73
SACPL-72/1800	77894	90	SACRKT-S/S	78401	99	SHIM-MDKIT	82394	144	SPG-CVR-B	77388	101
SACPL-72/1800	77894	97	SACSK	77052	91	SKPU-100x10x15.2	91293	175	SPG-CVR-C	77389	21
SACPL-72/1800-S/S	78378	78	SACSK	77052	93	SKPU-100x10x7.6	91288	175	SPG-CVR-C	77389	73
SACPL-72/1800-S/S	78378	85	SACSRC	77065	91	SKPU-100x12x15.2	91294	175	SPG-CVR-C	77389	101
SACPL-72/1800-S/S	78378	92	SACSRC	77065	93	SKPU-100x12x7.6	91289	175	SPG-CVR-D	77390	21
SACPL-72/1800-S/S	78378	98	SB-MB-S/S	A1535	120	SKPU-100x16x15.2	91295	175	SPG-CVR-D	77390	73
SACPL2-120/3000	77899	76	SB-UC38-S/S	A1536	120	SKPU-100x16x7.6	91290	175	SPG-CVR-D	77390	101
SACPL2-120/3000	77899	83	SB1050	A0334	120	SKPU-100x19x15.2	91296	175	SPG-CVR-E	77391	21
SACPL2-120/3000	77899	90	SB1050-SEC	61066	119	SKPU-100x19x7.6	91291	175	SPG-CVR-E	77391	73
SACPL2-120/3000	77899	97	SB1050A	A0435	119	SKPU-100x25x15.2	91297	175	SPG-CVR-E	77391	101
SACPL2-120/3000-S/S	78383	78	SB1200	A0863	120	SKPU-100x25x7.6	91292	175	SPG-CVR-F	77392	21
SACPL2-120/3000-S/S	78383	85	SB1200-SEC	61067	119	SKPU-150x10x15.2	91301	175	SPG-CVR-F	77392	73
SACPL2-120/3000-S/S	78383	92	SB1200A	A0316	119	SKPU-150x10x7.6	91298	175	SPG-CVR-F	77392	101
SACPL2-120/3000-S/S	78383	98	SB1400	A0827	120	SKPU-150x12x15.2	91222	175	SPG-CVR-G	77393	21
SACPL2-60/1500	77895	76	SB1400-SEC	61068	119	SKPU-150x12x7.6	90283	175	SPG-CVR-G	77393	73
SACPL2-60/1500	77895	83	SB1400A	A1620	119	SKPU-150x16x15.2	91302	175	SPG-CVR-G	77393	101
SACPL2-60/1500	77895	90	SB1500	A2033	120	SKPU-150x16x7.6	91299	175	SPG-CVR-H	77741	21



# INDEX By Ordering Number

Ordering Number	Item Code	Page #	Ordering Number	Item Code	Page #	Ordering Number	Item Code	Page #	Ordering Number	Item Code	Page #	
SPG-CVR-H	77741	73	STAKHD	75892	114	STS-W-S/S	77630	66	URVB36/900		76739	102
SPG-CVR-H	77741	101	STAKHD	75892	114	STS-W-S/S	77630	70	URVB36/900		76739	102
SRBK	74941	122	STCK	74506	37	STS-W-S/S	77630	93	URVB36/900		76739	103
SSFRB	78456	30	STCK-S/S	75425	37	STS-W-S/S	77630	109	URVB36/900		76739	103
SSRB	75978	30	STGK2	77635	70	STS-W-S/S	77630	114	URVB36/900		76739	106
SST1HDM-B	78519	70	STGK2	77635	70	STTS	74419	37	URVB42/1050		76740	102
SST1HDM-B	78519	91	STGK2	77635	91	STTS	74419	104	URVB42/1050		76740	102
SST1HDM-B	78519	109	STGK2	77635	93	STTS-S/S	75585	37	URVB42/1050		76740	103
SST1HDM-B-S/S	78396	70	STGK2	77635	109	STTS-S/S	75585	105	URVB42/1050		76740	103
SST1HDM-B-S/S	78396	93	STGK2	77635	109	TEN-LOCK-KIT	77443	21	URVB42/1050		76740	106
SST1HDM-B-S/S	78396	109	STGK2	77635	114	TEN-LOCK-KIT	77443	73	URVB48/1200		76741	102
SST1HDM-G	79069	70	STGK2	77635	114	TEN-LOCK-KIT	77443	101	URVB48/1200		76741	102
SST1HDM-G	79069	91	STHDMK2-S/S	77634	70	TRB18	76485	23	URVB48/1200		76741	103
SST1HDM-G	79069	93	STHDMK2-S/S	77634	93	TRB24	76486	23	URVB48/1200		76741	103
SST1HDM-G	79069	109	STHDMK2-S/S	77634	109	TRB30	76487	23	URVB48/1200		76741	106
SST1HDM-G-S/S	79454	70	STHDPM2-S/S	77633	70	TRB36	76488	23	URVB54/1350		76742	102
SST1HDM-S	78518	70	STHDPM2-S/S	77633	93	TRB42	76489	23	URVB54/1350		76742	102
SST1HDM-S	78518	91	STHDPM2-S/S	77633	109	TRB48	76490	23	URVB54/1350		76742	103
SST1HDM-S	78518	109	STJ-S/S	75426	105	TRB54	76491	23	URVB54/1350		76742	103
SST1HDM-S	78518	110	STJK	74417	37	TRB60	76492	23	URVB54/1350		76742	106
SST1HDM-S-S/S	78395	70	STJK	74417	37	TRB66	76493	23	URVB56/1400		77314	102
SST1HDM-S-S/S	78395	93	STJK	74417	104	TRB72	76494	23	URVB56/1400		77314	102
SST1HDM-S-S/S	78395	109	STJK-S/S	74417	105	TRB78	76697	23	URVB56/1400		77314	103
SST1HDM-W	78517	70	STJM	74775	37	TRB84	77047	23	URVB56/1400		77314	103
SST1HDM-W	78517	91	STJM	74775	37	TRB90	77048	23	URVB56/1400		77314	106
SST1HDM-W	78517	109	STJM	74775	104	UFB18	74448	106	URVB60/1500		76743	102
SST1HDM-W-S/S	78394	70	STJM-S/S	75426	37	UFB18-B	67327	106	URVB60/1500		76743	102
SST1HDM-W-S/S	78394	93	STJM-S/S	75426	37	UFB24	74449	106	URVB60/1500		76743	103
SST1HDM-W-S/S	78394	109	STKD	74504	37	UFB24-B	67328	106	URVB60/1500		76743	103
SSTBK-B	76637	70	STKD-S/S	75427	37	UFB30	74450	106	URVB60/1500		76743	106
SSTBK-B	76637	70	STLP	79535	116	UFB30-B	67329	106	URVB64/1600		77315	102
SSTBK-B	76637	91	STS-B	75844	35	UFB36	74451	106	URVB64/1600		77315	102
SSTBK-B	76637	93	STS-B	75844	35	UFB36-B	67330	106	URVB64/1600		77315	103
SSTBK-B	76637	109	STS-B	75844	55	UFB42	74452	106	URVB64/1600		77315	103
SSTBK-B	76637	109	STS-B	75844	64	UFB42-B	67331	106	URVB64/1600		77315	106
SSTBK-B	76637	114	STS-B	75844	66	UFB48	74453	106	URVB72/1800		76744	102
SSTBK-B	76637	114	STS-B	75844	70	UFB48-B	67332	106	URVB72/1800		76744	102
SSTBK-W	76636	70	STS-B	75844	91	UFB54	74454	106	URVB72/1800		76744	103
SSTBK-W	76636	70	STS-B	75844	109	UFB54-B	67333	106	URVB72/1800		76744	103
SSTBK-W	76636	91	STS-B	75844	114	UFB60	74455	106	URVB72/1800		76744	106
SSTBK-W	76636	93	STS-B-S/S	77632	35	UFB60-B	67334	106	URVB80/2000		77320	102
SSTBK-W	76636	109	STS-B-S/S	77632	35	UFB72	74456	106	URVB80/2000		77320	102
SSTBK-W	76636	109	STS-B-S/S	77632	64	UFB72-B	67335	106	URVB80/2000		77320	103
SSTBK-W	76636	114	STS-B-S/S	77632	66	UFB84	74460	106	URVB80/2000		77320	103
SSTBK-W	76636	114	STS-B-S/S	77632	70	UFB84-B	67336	106	URVB80/2000		77320	106
SSTBK-W	76636	110	STS-B-S/S	77632	93	UHPB	79207	104	URVB84/2100		76745	102
SSTHDPM	77868	70	STS-B-S/S	77632	109	UHPB	79207	105	URVB84/2100		76745	102
SSTHDPM	77868	91	STS-B-S/S	77632	114	UHSPK-M	82887	104	URVB84/2100		76745	103
SSTHDPM	77868	109	STS-G	78142	35	UHSPK-SS-M	82889	105	URVB84/2100		76745	103
SSTHDPM	77868	114	STS-G	78142	35	ULP1050	66126	127	URVB84/2100		76745	106
SSTHDPM2-S/S	77633	114	STS-G	78142	64	ULP1200	66127	127	URVB88/2200		77316	102
SSTHK	79582	70	STS-G	78142	66	ULP1350	66128	127	URVB88/2200		77316	102
SSTHK	79582	109	STS-G	78142	70	ULP1500	66129	127	URVB88/2200		77316	103
SSTHK	79582	114	STS-G	78142	91	ULP1650	66130	127	URVB88/2200		77316	103
SSTHK-S/S	78586	70	STS-G	78142	109	ULP1800	67057	127	URVB88/2200		77316	106
SSTHK-S/S	79586	109	STS-G	78142	114	ULP2000	67084	127	URVB94/2400		77421	102
SSTHK-S/S	79586	114	STS-G-S/S	79057	35	ULP2200	67085	127	URVB94/2400		77421	102
SSTLMB	76072	123	STS-G-S/S	79057	35	ULP2400	67058	127	URVB94/2400		77421	103
SSTSMB	76071	123	STS-G-S/S	79057	64	ULP2600	67086	127	URVB94/2400		77421	103
SSTXD-B	111784	114	STS-G-S/S	79057	66	ULP2800	67087	127	URVB94/2400		77421	106
SSTXD-B-S/S	111426	114	STS-G-S/S	79057	70	ULP3000	67088	127	URVB98/2500		77422	102
SSTXD-G	111785	114	STS-G-S/S	79057	109	ULP450	66122	127	URVB98/2500		77422	102
SSTXD-G-S/S	111427	114	STS-G-S/S	79057	114	ULP600	66123	127	URVB98/2500		77422	103
SSTXD-S	111783	114	STS-S	75843	55	ULP750	66124	127	URVB98/2500		77422	103
SSTXD-S-S/S	111425	114	STS-S	75843	64	ULP900	66125	127	URVB98/2500		77422	106
SSTXD-W	111782	114	STS-S	75843	66	UMBK-M	82890	104	USP18/450		82689	104
SSTXD-W-S/S	111424	114	STS-S	75843	70	UMBK-SS-M	82891	105	USP18/450-S/S		77339	105
SSTXDM	GR660	114	STS-S	75843	91	UNB60	61369	37	USP24/600		82690	104
SSTXDM-S/S	109827	114	STS-S	75843	109	UNB73	A2671	37	USP24/600-S/S		77340	105
SSTXDMK	91412	70	STS-S	75843	114	URVB18/450	76736	102	USP30/750		82691	104
SSTXDMK	91412	90	STS-S	75843	110	URVB18/450	76736	102	USP30/750-S/S		77341	105
SSTXDMK	91412	109	STS-S-S/S	77631	64	URVB18/450	76736	103	USP36/900		82692	104
STAK	75847	70	STS-S-S/S	77631	66	URVB18/450	76736	103	USP36/900-S/S		77342	105
STAK	75847	70	STS-S-S/S	77631	70	URVB18/450	76736	106	USP42/1050		82693	104
STAK	75847	91	STS-S-S/S	77631	93	URVB24/600	76737	102	USP42/1050-S/S		77343	105
STAK	75847	93	STS-S-S/S	77631	109	URVB24/600	76737	102	USP48/1200		82694	104
STAK	75847	109	STS-S-S/S	77631	114	URVB24/600	76737	103	USP48/1200-S/S		77344	105
STAK	75847	109	STS-W	75846	64	URVB24/600	76737	103	USP54/1350		82695	104
STAKHD	75892	70	STS-W	75846	66	URVB24/600	76737	106	USP54/1350-S/S		77345	105
STAKHD	75892	70	STS-W	75846	70	URVB30/750	76738	102	USP56/1400		82696	104
STAKHD	75892	91	STS-W	75846	91	URVB30/750	76738	102	USP56/1400-S/S		77346	105
STAKHD	75892	93	STS-W	75846	109	URVB30/750	76738	103	USP60/1500		82697	104
STAKHD	75892	109	STS-W	75846	114	URVB30/750	76738	103	USP60/1500-S/S		77347	105
STAKHD	75892	109	STS-W-S/S	77630	64	URVB30/750	76738	106	USP64/1600		82698	104

# INDEX By Ordering Number

Ordering Number	Item Code	Page #	Ordering Number	Item Code	Page #	Ordering Number	Item Code	Page #	Ordering Number	Item Code	Page #
USP64/1600-S/S	77348	105	UTV600-S/S	82708	102	YSTHDBK-B	79856	55	YTHD-1200S	83122	52
USP72/1800	82699	104	UTV600J-S/S	77260	103	YSTHDBK-W	79853	55	YTHD-1350S	83123	52
USP72/1800-S/S	77349	105	UTV750	77299	102	YSTHDBK	79850	55	YTHD-1500S	83124	52
USP80/2000	82700	104	UTV750-J	77285	103	YSTHDGBK	79851	55	YTHD-1800S	83126	52
USP80/2000-S/S	77350	105	UTV750-S/S	82709	102	YSTHDLBK	79852	55	YTHD-900S	83120	52
USP84/2100	82701	104	UTV750J-S/S	77261	103	YSTHDMB	79849	55	YTHD-TC-1050S	83135	52
USP84/2100-S/S	77351	105	UTV900	77300	102	YSTHDS-BL	79798	55	YTHD-TC-1200S	83136	52
USP88/2200	82702	104	UTV900-J	77286	103	YSTHDS-GR	79797	55	YTHD-TC-1350S	83137	52
USP88/2200-S/S	77352	105	UTV900-S/S	82710	102	YSTLBK	79846	51	YTHD-TC-1500S	83138	52
USP94/2400	82703	104	UTV900J-S/S	77262	103	YSTMB	79843	51	YTHD-TC-1800S	83140	52
USP94/2400-S/S	77419	105	WCB	A0012	119	YSTPHDMK	79854	55	YTHD-TC-900S	83134	52
USP98/2500	82704	104	WCB	A0012	120	YSTPMK	79848	51	YTHDR-36S	91816	52
USP98/2500-S/S	77420	105	YCART-18/450-P	79617	49	YSTS-P	79796	51	YTHDR-42S	91817	52
USPB	79206	104	YCART-18/450-R	91805	49	YSTS-Y	79795	51	YTHDR-48S	91818	52
USPB	79206	105	YCART-18/450-TC	79811	49	YSTTBK-B	79855	51	YTHDR-54S	91819	52
USPB2	79206	104	YCART-24/600-P	79618	49	YSTTBK-W	79847	51	YTHDR-60S	91820	52
USPB2	79206	105	YCART-24/600-R	91806	49	YT-1050S	83233	48	YTHDR-72S	91821	52
USPK	76790	104	YCART-24/600-TC	79812	49	YT-1200S	83234	48	YTP-18/450	82932	51
USPK-SS-M	82888	105	YCART-30/750-P	79619	49	YT-450S	83229	48	YTP-24/600	82933	51
UST	GN812	104	YCART-30/750-R	91807	49	YT-600S	83230	48	YTP-30/750	82934	51
UST	GN812	105	YCART-30/750-TC	79813	49	YT-750S	83231	48	YTP-36/900	82935	51
UST-G-MT	82900	104	YCART-36/900-HDP	79817	53	YT-900S	83232	48	YTP-42/1050	82936	51
UST-G-MT-SS	82904	105	YCART-36/900-HDR	91823	53	YT-C*	79574	49	YTP-48/1200	82937	51
UST-P-MT	82897	104	YCART-36/900-HDTC	79829	53	YT-HDC*	79728	53	YTPHD-36/900	83106	55
UST-P-MT-SS	82901	105	YCART-36/900-P	79620	49	YT-HDP*	79677	53	YTPHD-42/1050	83107	55
UST-S-MT	82898	104	YCART-36/900-R	91808	49	YT-HDR*	91822	53	YTPHD-48/1200	83108	55
UST-S-MT-SS	82902	105	YCART-36/900-TC	79814	49	YT-P*	79573	49	YTPHD-54/1350	83109	55
UST-W-MT	82899	104	YCART-42/1050-HDP	79818	53	YT-R*	91804	49	YTPHD-60/1500	83110	55
UST-W-MT-SS	82903	105	YCART-42/1050-HDR	91824	53	YT-TC-1050S	83245	48	YTPHD-72/1800	83112	55
UTS	74420	37	YCART-42/1050-HDTC	79830	53	YT-TC-1200S	83246	48	YTR-18S	91798	48
UTV1050	77301	102	YCART-42/1050-P	79621	49	YT-TC-450S	83241	48	YTR-24S	91799	48
UTV1050-J	77287	103	YCART-42/1050-R	91809	49	YT-TC-600S	83242	48	YTR-30S	91800	48
UTV1050-S/S	82711	102	YCART-42/1050-TC	79815	49	YT-TC-750S	83243	48	YTR-36S	91801	48
UTV1050J-S/S	77263	103	YCART-48/1200-HDP	79819	53	YT-TC-900S	83244	48	YTR-42S	91802	48
UTV1200	77302	102	YCART-48/1200-HDR	91825	53	YTA-18/450	82949	51	YTR-48S	91803	48
UTV1200-J	77288	103	YCART-48/1200-HDTC	79831	53	YTA-24/600	82950	51			
UTV1200-S/S	82712	102	YCART-48/1200-P	79622	49	YTA-30/750	82951	51			
UTV1200J-S/S	77264	103	YCART-48/1200-R	91810	49	YTA-36/900	82952	51			
UTV1350	77303	102	YCART-48/1200-TC	79816	49	YTA-42/1050	82953	51			
UTV1350-J	77289	103	YCART-54/1350-HDP	79820	53	YTA-48/1200	82954	51			
UTV1350-S/S	82713	102	YCART-54/1350-HDR	91826	53	YTAC	79623	51			
UTV1350J-S/S	77265	103	YCART-54/1350-HDTC	79832	53	YTACHD	79835	55			
UTV1400	77304	102	YCART-60/1500-HDP	79821	53	YTAHD-36/900	79805	55			
UTV1400-J	77290	103	YCART-60/1500-HDR	91827	53	YTAHD-42/1050	79806	55			
UTV1400-S/S	82714	102	YCART-60/1500-HDTC	79833	53	YTAHD-48/1200	79807	55			
UTV1400J-S/S	77266	103	YCART-72/1800-HDP	79822	53	YTAHD-54/1350	79808	55			
UTV1500	77305	102	YCART-72/1800-HDR	91828	53	YTAHD-60/1500	79809	55			
UTV1500-J	77291	103	YCART-72/1800-HDTC	79834	53	YTAHD-72/1800	79810	55			
UTV1500-S/S	82715	102	YCART-S/S-24/600-SDTC	66749	57	YTC-1050	83227	48			
UTV1500J-S/S	77267	103	YCART-S/S-30/750-SDTC	67750	57	YTC-1200	83228	48			
UTV1600	77306	102	YCART-S/S-36/900-HDP	67417	57	YTC-450	83223	48			
UTV1600-J	77292	103	YCART-S/S-36/900-HDTC	67411	57	YTC-600	83224	48			
UTV1600-S/S	82716	102	YCART-S/S-36/900-SDTC	67751	57	YTC-750	83225	48			
UTV1600J-S/S	77268	103	YCART-S/S-42/1050-HDP	67418	57	YTC-900	83226	48			
UTV1800	77307	102	YCART-S/S-42/1050-HDTC	67412	57	YTC1050-BT-S/S SECONDARY	67288	56			
UTV1800-J	77293	103	YCART-S/S-42/1050-SDTC	67752	57	YTC1200-BT-S/S SECONDARY	67289	56			
UTV1800-S/S	82717	102	YCART-S/S-48/1200-HDP	67419	57	YTC600-BT-S/S SECONDARY	67285	56			
UTV1800J-S/S	77269	103	YCART-S/S-48/1200-HDTC	67413	57	YTC750-BT-S/S SECONDARY	67286	56			
UTV2000	77308	102	YCART-S/S-48/1200-SDTC	67753	57	YTC900-BT-S/S SECONDARY	67287	56			
UTV2000-J	77294	103	YCART-S/S-54/1350-HDP	67420	57	YTCHD-1050	83100	52			
UTV2000-S/S	82718	102	YCART-S/S-54/1350-HDTC	67414	57	YTCHD-1200	83101	52			
UTV2000J-S/S	77270	103	YCART-S/S-60/1500-HDP	67421	57	YTCHD-1350	83102	52			
UTV2100	77309	102	YCART-S/S-60/1500-HDTC	67415	57	YTCHD-1500	83103	52			
UTV2100-J	77295	103	YCART-S/S-72/1800-HDP	67422	57	YTCHD-1800	83105	52			
UTV2100-S/S	82719	102	YCART-S/S-72/1800-HDTC	67416	57	YTCHD-900	83099	52			
UTV2100J-S/S	77271	103	YPHD1050-S/S POLE	64199	57	YTCHD1050-BT-S/S SECONDARY	67291	56			
UTV2200	77310	102	YPHD1200-S/S POLE	64200	57	YTCHD1050-MST-S/S SECONDARY	67309	56			
UTV2200-J	77296	103	YPHD1350-S/S POLE	64201	57	YTCHD1200-BT-S/S SECONDARY	67292	56			
UTV2200-S/S	82720	102	YPHD1500-S/S POLE	64202	57	YTCHD1200-MST-S/S SECONDARY	67310	56			
UTV2200J-S/S	77272	103	YPHD1800-S/S POLE	64204	57	YTCHD1350-BT-S/S SECONDARY	67293	56			
UTV2400	77411	102	YPHD600-S/S POLE	67322	57	YTCHD1350-MST-S/S SECONDARY	67311	56			
UTV2400-J	77413	103	YPHD750-S/S POLE	67323	57	YTCHD1500-BT-S/S SECONDARY	67294	56			
UTV2400-S/S	82721	102	YPHD900-S/S POLE	64198	57	YTCHD1500-MST-S/S SECONDARY	67312	56			
UTV2400J-S/S	77417	103	YST-P	79837	51	YTCHD1800-BT-S/S SECONDARY	67295	56			
UTV2500	77412	102	YST-S	79838	51	YTCHD1800-MST-S/S SECONDARY	67313	56			
UTV2500-J	77414	103	YST-Y	79836	51	YTCHD900-BT-S/S SECONDARY	67290	56			
UTV2500-S/S	82722	102	YSTANK	79857	51	YTCHD900-MST-S/S SECONDARY	67308	56			
UTV2500J-S/S	77418	103	YSTANKHD	79858	55	YTFHD1050-MST-S/S SECONDARY	67315	56			
UTV450	77297	102	YSTDBK2	113390	51	YTFHD1200-MST-S/S SECONDARY	67316	56			
UTV450-J	77283	103	YSTGBK	79845	51	YTFHD1350-MST-S/S SECONDARY	67317	56			
UTV450-S/S	82707	102	YSTDH-BK	79842	55	YTFHD1500-MST-S/S SECONDARY	67318	56			
UTV450J-S/S	77259	103	YSTDH-BL	79841	55	YTFHD1800-MST-S/S SECONDARY	67319	56			
UTV600	77298	102	YSTDH-GR	79839	55	YTFHD900-MST-S/S SECONDARY	67314	56			
UTV600-J	77284	103	YSTDH-S	79840	55	YTHD-1050S	83121	52			

# INDEX By Ordering Number

Ordering Number	Item Code	Page #	Ordering Number	Item Code	Page #	Ordering Number	Item Code	Page #	Ordering Number	Item Code	Page #

# INDEX By Item Code

Item Code	Ordering Number	Page #	Item Code	Ordering Number	Page #	Item Code	Ordering Number	Page #	Item Code	Ordering Number	Page #
26184	NI6D3T-24-9-A45	139	61369	UNB60	37	62505	HSABCS	41	62548	H-CARK-1400-CS	38
26185	NI6D3T-30-11-A45	139	61471	FLSCM2000-S/S	173	62505	HSABCS	42	62549	H-CARK-1400-CM	38
26186	NI6D3T-36-13-A45	139	61491	EZP1P48-S/S	17	62505	HSABCS	45	62550	H-CARK-1400-CL	38
26187	NI6D3T-42-15-A45	139	61742	FRPU150	59	62505	HSABCS	46	62551	H-CARK-1600-CS	38
26188	NI6D3T-48-17-A45	139	62034	AIR HDMRK S/S	35	62505	HSABCS	47	62552	H-CARK-1600-CM	38
26189	NI6D3T-54-19-A45	139	62035	AIR HARK-S/S-60	35	62506	HSAB-CM	40	62553	H-CARK-1600-CL	38
26190	NI6D3T-60-21-A45	139	62036	AIR BAG P	35	62506	HSABCM	41	62554	H-CARK-1800-CS	38
26191	NI6D3T-72-25-A45	139	62037	ATV-NIP	35	62506	HSABCM	42	62555	H-CARK-1800-CM	38
30001	EBC-1	134	62037	ATV-NIP	71	62506	HSABCM	45	62556	H-CARK-1800-CL	38
30002	EBC-2	134	62037	ATV-NIP	91	62506	HSABCM	46	62557	HV-1200-2SAC-CS	38
30003	EBC-1-B	134	62079	ATV-BAG	71	62506	HSABCM	47	62558	HV-1200-2SAC-CM	38
30004	EBC-2-B	134	62079	ATV-BAG	91	62507	HSAB-CL	40	62559	HV-1200-2SAC-CL	38
30009	EBC1 Case	134	62094	PSA150-EL15	59	62507	HSABCL	41	62560	HV-1200-2SAC-CLL	38
30010	EBC2 Case	134	62094	PSA150-EL15	77	62507	HSABCL	42	62561	HV-1400-2SAC-CS	38
30018	CEBC-1	134	62095	CRHMK-S/S	79	62507	HSABCL	45	62562	HV-1400-2SAC-CM	38
30019	CEBC-2	134	62095	CRHMK-S/S	86	62507	HSABCL	46	62563	HV-1400-2SAC-CL	38
30020	CEBC1 Case	134	62095	CRHMK-S/S	99	62507	HSABCL	47	62564	HV-1400-2SAC-CLL	38
30023	CEBC2 Case	134	62254	HVT8-EL15-S/S	34	62508	HSAB-CLL	40	62565	HV-1600-2SAC-CM	38
30033	EBC1-RK	134	62254	HVT8-EL15-S/S	46	62508	HSABCLL	41	62566	HV-1600-2SAC-CL	38
30034	EBC2-RK	134	62254	HVT8-EL15-S/S	47	62508	HSABCLL	42	62567	HV-1600-2SAC-CLL	38
61001	HDPHSC-S/S	59	62400	CRHMK	77	62508	HSABCLL	45	62568	HV-1800-2SAC-CM	38
61001	HDPHSC-S/S	79	62400	CRHMK	84	62508	HSABCLL	46	62569	HV-1800-2SAC-CL	38
61003	HDPHC	59	62400	CRHMK	97	62508	HSABCLL	47	62570	HV-1800-2SAC-CLL	38
61003	HDPHC	77	62409	ATVK-60	71	62509	HSABCS-S/S	40	62571	HV-2000-2SAC-CM	38
61016	EZP1-242-S/S	14	62409	ATVK-60	91	62509	HSABCS-S/S	41	62572	HV-2000-2SAC-CL	38
61017	EZP1-230-S/S	14	62424	ATV-MOUNT	71	62509	HSABCS-S/S	42	62573	HV-2000-2SAC-CLL	38
61050	CBD-ST-L	159	62424	ATV-MOUNT	91	62509	HSABCS-S/S	45	62574	HV-2200-2SAC-CM	38
61051	CBD-ST-XL	159	62425	ATV-SLIDE	71	62509	HSABCS-S/S	46	62575	HV-2200-2SAC-CL	38
61057	HEX Plug 3/4	120	62425	ATV-SLIDE	91	62509	HSABCS-S/S	47	62576	HV-2200-2SAC-CLL	38
61058	Reduce Adap F 3/4	120	62426	ATV-ANGLE	71	62510	HSABCM-S/S	40	62577	HV-2400-2SAC-CM	38
61063	SB600-SEC	119	62426	ATV-ANGLE	91	62510	HSABCM-S/S	41	62578	HV-2400-2SAC-CL	38
61064	SB750-SEC	119	62445		130	62510	HSABCM-S/S	42	62579	HV-2400-2SAC-CLL	38
61065	SB900-SEC	119	62446		130	62510	HSABCM-S/S	45	62589	HCSSB-B/G	35
61066	SB1050-SEC	119	62447		130	62510	HSABCM-S/S	46	62589	HCSSB-B/G	35
61067	SB1200-SEC	119	62448		130	62510	HSABCM-S/S	47	62589	HCSSB-B/G	35
61068	SB1400-SEC	119	62452	H-SAC-AP-600	41	62511	HSABCL-S/S	40	62589	HCSSB-B/G	35
61069	SB1500-SEC	119	62452	H-SAC-AP-600	42	62511	HSABCL-S/S	41	62590	HCSSB-S	35
61070	SB1800-SEC	119	62452	H-SAC-AP-600	42	62511	HSABCL-S/S	42	62590	HCSSB-S	35
61073	PMR-CHB-L60	132	62452	H-SAC-AP-600	42	62511	HSABCL-S/S	45	62591	ACME-N	35
61074	PMR-CHB-R60	132	62452	H-SAC-AP-600	46	62511	HSABCL-S/S	46	62591	ACME-N	35
61075	PMR-CHB-L73	132	62452	H-SAC-AP-600	47	62511	HSABCL-S/S	47	62591	ACME-N	35
61076	PMR-CHB-R73	132	62452	H-SAC-AP-600	47	62512	HSABCLL-S/S	40	62591	ACME-N	35
61077	CBD-ST-M	159	62452	H-SAC-AP-600	47	62512	HSABCLL-S/S	41	62595	DBK-XXL	158
61079	CBD-ST-M-S/S	159	62453	H-SAC-AP-800	41	62512	HSABCLL-S/S	42	62599	H-CARK2-1200-CS	38
61080	CBD-ST-L-S/S	159	62453	H-SAC-AP-800	42	62512	HSABCLL-S/S	45	62600	H-CARK2-1200-CM	38
61081	EZP1-218-S/S	14	62453	H-SAC-AP-800	42	62512	HSABCLL-S/S	46	62601	H-CARK2-1200-CL	38
61082	EZP1-224-S/S	14	62453	H-SAC-AP-800	42	62512	HSABCLL-S/S	47	62602	H-CARK2-1200-CLL	38
61083	EZP1-236-S/S	14	62453	H-SAC-AP-800	42	62513	HCSBB-60	35	62603	H-CARK2-1400-CS	38
61084	EZP1-248-S/S	14	62453	H-SAC-AP-800	46	62513	HCSBB-60	35	62604	H-CARK2-1400-CM	38
61085	EZP1-254-S/S	14	62453	H-SAC-AP-800	47	62514	HCSBB-73	35	62605	H-CARK2-1400-CL	38
61086	EZP1-260-S/S	14	62453	H-SAC-AP-800	47	62514	HCSBB-73	35	62606	H-CARK2-1400-CLL	38
61087	EZP1-272-S/S	14	62453	H-SAC-AP-800	47	62515	HV-600-SAC-CS	38	62607	H-CARK2-1600-CM	38
61096	CBD-ST-AA	159	62453	H-SAC-AP-800	47	62516	HV-600-SAC-CM	38	62608	H-CARK2-1600-CL	38
61105	CBD-ST-M-MF	159	62454	H-SAC-AP-1000	41	62517	HV-600-SAC-CL	38	62609	H-CARK2-1600-CLL	38
61106	CBD-ST-L-MF	159	62454	H-SAC-AP-1000	42	62518	HV-800-SAC-CS	38	62610	H-CARK2-1800-CM	38
61107	CBD-ST-XL-MF	159	62454	H-SAC-AP-1000	42	62519	HV-800-SAC-CM	38	62611	H-CARK2-1800-CL	38
61108	CBD-ST-M-MF-S/S	159	62454	H-SAC-AP-1000	42	62520	HV-800-SAC-CL	38	62612	H-CARK2-1800-CLL	38
61109	CBD-ST-L-MF-S/S	159	62454	H-SAC-AP-1000	42	62521	HV-1000-SAC-CS	38	62613	H-CARK2-2000-CM	38
61110	CBD-ST-XL-MF-S/S	159	62454	H-SAC-AP-1000	46	62522	HV-1000-SAC-CM	38	62614	H-CARK2-2000-CL	38
61111	CBD-ST-FR-B	159	62454	H-SAC-AP-1000	47	62523	HV-1000-SAC-CL	38	62615	H-CARK2-2000-CLL	38
61112	CBD-ST-M-FP	159	62454	H-SAC-AP-1000	47	62524	HV-1200-SAC-CS	38	62616	H-CARK2-2200-CM	38
61113	CBD-ST-L-FP	159	62454	H-SAC-AP-1000	47	62525	HV-1200-SAC-CM	38	62617	H-CARK2-2200-CL	38
61114	CBD-ST-XL-FP	159	62454	H-SAC-AP-1000	47	62526	HV-1200-SAC-CL	38	62618	H-CARK2-2200-CLL	38
61141	RSA150-EL15	61	62455	H-SAC-AP-1200	41	62527	HV-1400-SAC-CS	38	62619	H-CARK2-2400-CM	38
61141	RSA150-EL15	62	62455	H-SAC-AP-1200	42	62528	HV-1400-SAC-CM	38	62620	H-CARK2-2400-CL	38
61141	RSA150-EL15	64	62455	H-SAC-AP-1200	42	62529	HV-1400-SAC-CL	38	62621	H-CARK2-2400-CLL	38
61141	RSA150-EL15	66	62455	H-SAC-AP-1200	42	62530	HV-1600-SAC-CM	38	62631	HV-600-SAC-CS-S/S	39
61141	RSA150-EL15	68	62455	H-SAC-AP-1200	46	62531	HV-1600-SAC-CL	38	62632	HV-600-SAC-CM-S/S	39
61141	RSA150-EL15	70	62455	H-SAC-AP-1200	47	62532	HV-1600-SAC-CLL	38	62633	HV-600-SAC-CL-S/S	39
61141	RSA150-EL15	84	62455	H-SAC-AP-1200	47	62533	HV-1800-SAC-CM	38	62634	HV-800-SAC-CS-S/S	39
61141	RSA150-EL15	90	62455	H-SAC-AP-1200	47	62534	HV-1800-SAC-CL	38	62635	HV-800-SAC-CM-S/S	39
61141	RSA150-EL15	97	62456	H-SAC-AP-1400	41	62535	HV-1800-SAC-CLL	38	62636	HV-800-SAC-CL-S/S	39
61173	HSTSS	37	62456	H-SAC-AP-1400	46	62536	H-CARK-600-CS	38	62637	HV-1000-SAC-CS-S/S	39
61182	EZP1P18-S/S	17	62457	H-SAC-AP-1600	41	62537	H-CARK-600-CM	38	62638	HV-1000-SAC-CM-S/S	39
61183	EZP1P42-S/S	17	62457	H-SAC-AP-1600	46	62538	H-CARK-600-CL	38	62639	HV-1000-SAC-CL-S/S	39
61184	EZP1P54-S/S	17	62458	H-SAC-AP-1800	41	62539	H-CARK-800-CS	38	62640	HV-1200-SAC-CS-S/S	39
61185	EZP1P60-S/S	17	62458	H-SAC-AP-1800	46	62540	H-CARK-800-CM	38	62641	HV-1200-SAC-CM-S/S	39
61186	EZP1P72-S/S	17	62494	HCSTAK	35	62541	H-CARK-800-CL	38	62642	HV-1200-SAC-CL-S/S	39
61270	RPHD2000-S/S	61	62495	HCSTAK-S/S	35	62542	H-CARK-1000-CS	38	62643	HV-1400-SAC-CS-S/S	39
61271	RPHD2400-S/S	61	62496	ACME-PRK	35	62543	H-CARK-1000-CM	38	62644	HV-1400-SAC-CM-S/S	39
61287	SB2100	120	62496	ACME-PRK	35	62544	H-CARK-1000-CL	38	62645	HV-1400-SAC-CL-S/S	39
61356	PBC-1	134	62496	ACME-PRK	35	62545	H-CARK-1200-CS	38	62646	HV-1600-SAC-CM-S/S	39
61357	PBC-2	134	62496	ACME-PRK	35	62546	H-CARK-1200-CM	38	62647	HV-1600-SAC-CL-S/S	39
61358	PBC-FR	134	62505	HSAB-CS	40	62547	H-CARK-1200-CL	38	62648	HV-1600-SAC-CLL-S/S	39

# INDEX By Item Code

Item Code	Ordering Number	Page #	Item Code	Ordering Number	Page #	Item Code	Ordering Number	Page #	Item Code	Ordering Number	Page #
62649	HV-1800-SAC-CM-S/S	39	62744	H73CSK-G-S/S	46	62838	EZP-LS224-S/S	10	63431	HV-1600-2SAC-CLL-EL15	43
62650	HV-1800-SAC-CL-S/S	39	62744	H73CSK-G-S/S	47	62839	EZP-LS230-S/S	10	63432	HV-1800-2SAC-CM-EL15	40
62651	HV-1800-SAC-CLL-S/S	39	62745	H73CSK-S	35	62840	EZP-LS236-S/S	10	63433	HV-1800-2SAC-CL-EL15	43
62652	H CARK-600-CS-S/S	39	62745	H73CSK-S	42	62841	EZP-LS242-S/S	10	63434	HV-1800-2SAC-CLL-EL15	43
62653	H CARK-600-CM-S/S	39	62745	H73CSK-S	47	62842	EZP-LS248-S/S	10	63435	HV-2000-2SAC-CM-EL15	40
62654	H CARK-600-CL-S/S	39	62746	H73CSK-S-S/S	35	62843	EZP-LS254-S/S	10	63436	HV-2000-2SAC-CL-EL15	43
62655	H CARK-800-CS-S/S	39	62746	H73CSK-S-S/S	42	62844	EZP-LS260-S/S	10	63437	HV-2000-2SAC-CLL-EL15	43
62656	H CARK-800-CM-S/S	39	62746	H73CSK-S-S/S	47	62845	EZP-LS212HT-S/S	10	63438	HV-2200-2SAC-CM-EL15	40
62657	H CARK-800-CL-S/S	39	62747	H60CSK-B	35	62846	EZP-LS218HT-S/S	10	63439	HV-2200-2SAC-CL-EL15	43
62658	H CARK-1000-CS-S/S	39	62747	HCSTK-60-B	37	62847	EZP-LS224HT-S/S	10	63440	HV-2200-2SAC-CLL-EL15	43
62659	H CARK-1000-CM-S/S	39	62748	H60CSK-B-S/S	35	62848	EZP-LS230HT-S/S	10	63441	HV-2400-2SAC-CM-EL15	40
62660	H CARK-1000-CL-S/S	39	62748	HCSTK-60-B-S/S	37	62849	EZP-LS236HT-S/S	10	63442	HV-2400-2SAC-CL-EL15	43
62661	H CARK-1200-CS-S/S	39	62749	H73CSK-B	35	62850	EZP-LS242HT-S/S	10	63443	HV-2400-2SAC-CLL-EL15	43
62662	H CARK-1200-CM-S/S	39	62749	H73CSK-B	37	62851	EZP-LS248HT-S/S	10	63453	HV-1200-2SAC-CL-S/EL15	44
62663	H CARK-1200-CL-S/S	39	62749	H73CSK-B	41	62852	EZP-LS254HT-S/S	10	63454	HV-1200-2SAC-CM-S/S-EL15	44
62664	H CARK-1400-CS-S/S	39	62749	H73CSK-B	42	62853	EZP-LS260HT-S/S	10	63455	HV-1200-2SAC-CL-S/EL15	44
62665	H CARK-1400-CM-S/S	39	62749	H73CSK-B	46	63020	MSTHD-G	64	63456	HV-1200-2SAC-CL-S/EL15	44
62666	H CARK-1400-CL-S/S	39	62749	H73CSK-B	47	63020	MSTHD-G	66	63457	HV-1400-2SAC-CS-S/EL15	44
62667	H CARK-1600-CS-S/S	39	62750	H73CSK-B-S/S	35	63020	MSTHD-G	71	63458	HV-1400-2SAC-CM-S/S-EL15	44
62668	H CARK-1600-CM-S/S	39	62750	H73CSK-B-S/S	37	63024	CBD-ST-XL-S	159	63459	HV-1400-2SAC-CL-S/EL15	44
62669	H CARK-1600-CL-S/S	39	62750	H73CSK-B-S/S	41	63067	MSTBBK	64	63460	HV-1400-2SAC-CLL-S/EL15	44
62670	H CARK-1800-CS-S/S	39	62750	H73CSK-B-S/S	42	63067	MSTBBK	64	63461	HV-1600-2SAC-CM-S/S-EL15	44
62671	H CARK-1800-CM-S/S	39	62750	H73CSK-B-S/S	46	63067	MSTBBK	66	63462	HV-1600-2SAC-CL-S/EL15	44
62672	H CARK-1800-CL-S/S	39	62750	H73CSK-B-S/S	47	63067	MSTBBK	66	63463	HV-1600-2SAC-CLL-S/EL15	44
62673	HV-1200-2SAC-CS-S/S	39	62751	HCP-600	41	63072	ATVK-73	71	63464	HV-1800-2SAC-CM-S/S-EL15	44
62674	HV-1200-2SAC-CM-S/S	39	62751	HCP-600	46	63072	ATVK-73	91	63465	HV-1800-2SAC-CL-S/EL15	44
62675	HV-1200-2SAC-CL-S/S	39	62752	HCP-800	41	63073	ATV-MOUNT	71	63466	HV-1800-2SAC-CLL-S/EL15	44
62676	HV-1200-2SAC-CLL-S/S	39	62752	HCP-800	46	63073	ATV-MOUNT	91	63467	HV-2000-2SAC-CM-S/S-EL15	44
62677	HV-1400-2SAC-CS-S/S	39	62753	HCP-1000	41	63080	H73BTK-S/S	41	63468	HV-2000-2SAC-CL-S/EL15	44
62678	HV-1400-2SAC-CM-S/S	39	62753	HCP-1000	46	63080	H73BTK-S/S	42	63469	HV-2000-2SAC-CLL-S/EL15	44
62679	HV-1400-2SAC-CL-S/S	39	62754	HCP-1200	41	63080	H73BTK-S/S	46	63470	HV-2200-2SAC-CM-S/S-EL15	44
62680	HV-1400-2SAC-CLL-S/S	39	62754	HCP-1200	46	63080	H73BTK-S/S	47	63471	HV-2200-2SAC-CL-S/EL15	44
62681	HV-1600-2SAC-CM-S/S	39	62755	HCP-1400	41	63206	HV-600-SAC-CS-EL15	43	63472	HV-2200-2SAC-CLL-S/EL15	44
62682	HV-1600-2SAC-CL-S/S	39	62755	HCP-1400	46	63207	HV-600-SAC-CM-EL15	43	63473	HV-2400-2SAC-CM-S/S-EL15	44
62683	HV-1600-2SAC-CLL-S/S	39	62756	HCP-1800	41	63208	HV-600-SAC-CL-EL15	43	63474	HV-2400-2SAC-CL-S/EL15	44
62684	HV-1800-2SAC-CM-S/S	39	62756	HCP-1800	46	63209	HV-800-SAC-CS-EL15	43	63475	HV-2400-2SAC-CLL-S/EL15	44
62685	HV-1800-2SAC-CL-S/S	39	62757	HCP-600-S/S	41	63210	HV-800-SAC-CM-EL15	43	63554	CBD-XL-S/S	158
62686	HV-1800-2SAC-CLL-S/S	39	62757	HCP-600-S/S	46	63211	HV-800-SAC-CL-EL15	43	63567	H-CARK2-1200-CS-EL15	43
62687	HV-2000-2SAC-CM-S/S	39	62758	HCP-800-S/S	41	63212	HV-1000-SAC-CS-EL15	43	63568	H-CARK2-1200-CM-EL15	43
62688	HV-2000-2SAC-CL-S/S	39	62758	HCP-800-S/S	46	63213	HV-1000-SAC-CM-EL15	43	63569	H-CARK2-1200-CL-EL15	43
62689	HV-2000-2SAC-CLL-S/S	39	62759	HCP-1000-S/S	41	63214	HV-1000-SAC-CL-EL15	43	63570	H-CARK2-1200-CLL-EL15	43
62690	HV-2200-2SAC-CM-S/S	39	62759	HCP-1000-S/S	46	63215	HV-1200-SAC-CS-EL15	43	63571	H-CARK2-1400-CS-EL15	43
62691	HV-2200-2SAC-CL-S/S	39	62760	HCP-1200-S/S	41	63216	HV-1200-SAC-CM-EL15	43	63572	H-CARK2-1400-CM-EL15	43
62692	HV-2200-2SAC-CLL-S/S	39	62760	HCP-1200-S/S	46	63217	HV-1200-SAC-CL-EL15	43	63573	H-CARK2-1400-CL-EL15	43
62693	HV-2400-2SAC-CM-S/S	39	62761	HCP-1400-S/S	41	63218	HV-1400-SAC-CS-EL15	43	63574	H-CARK2-1400-CLL-EL15	43
62694	HV-2400-2SAC-CL-S/S	39	62761	HCP-1400-S/S	46	63219	HV-1400-SAC-CM-EL15	43	63575	H-CARK2-1600-CM-EL15	43
62695	HV-2400-2SAC-CLL-S/S	39	62762	HCP-1800-S/S	41	63220	HV-1400-SAC-CL-EL15	43	63576	H-CARK2-1600-CL-EL15	43
62705	H-CARK2-1200-CS-S/S	39	62762	HCP-1800-S/S	46	63221	HV-1600-SAC-CM-EL15	43	63577	H-CARK2-1600-CLL-EL15	43
62706	H-CARK2-1200-CM-S/S	39	62763	H2CP-1200	42	63222	HV-1600-SAC-CL-EL15	43	63578	H-CARK2-1800-CM-EL15	43
62707	H-CARK2-1200-CL-S/S	39	62763	H2CP-1200	47	63223	HV-1600-SAC-CLL-EL15	43	63579	H-CARK2-1800-CL-EL15	43
62708	H-CARK2-1200-CLL-S/S	39	62764	H2CP-1400	42	63224	HV-1800-SAC-CM-EL15	43	63580	H-CARK2-1800-CLL-EL15	43
62709	H-CARK2-1400-CS-S/S	39	62764	H2CP-1400	47	63225	HV-1800-SAC-CL-EL15	43	63581	H-CARK2-2000-CM-EL15	43
62710	H-CARK2-1400-CM-S/S	39	62765	H2CP-1600	42	63226	HV-1800-SAC-CLL-EL15	43	63582	H-CARK2-2000-CL-EL15	43
62711	H-CARK2-1400-CL-S/S	39	62765	H2CP-1600	47	63227	HV-600-SAC-CS-S/S-EL15	44	63583	H-CARK2-2000-CLL-EL15	43
62712	H-CARK2-1400-CLL-S/S	39	62766	H2CP-1800	42	63228	HV-600-SAC-CM-S/S-EL15	44	63584	H-CARK2-2200-CM-EL15	43
62713	H-CARK2-1600-CM-S/S	39	62766	H2CP-1800	47	63229	HV-600-SAC-CL-S/S-EL15	44	63585	H-CARK2-2200-CL-EL15	43
62714	H-CARK2-1600-CL-S/S	39	62767	H2CP-2000	42	63230	HV-800-SAC-CS-S/S-EL15	44	63586	H-CARK2-2200-CLL-EL15	43
62715	H-CARK2-1600-CLL-S/S	39	62767	H2CP-2000	47	63231	HV-800-SAC-CM-S/S-EL15	44	63587	H-CARK2-2400-CM-EL15	43
62716	H-CARK2-1800-CM-S/S	39	62768	H2CP-2400	42	63232	HV-800-SAC-CL-S/S-EL15	44	63588	H-CARK2-2400-CL-EL15	43
62717	H-CARK2-1800-CL-S/S	39	62768	H2CP-2400	47	63233	HV-1000-SAC-CS-S/S-EL15	44	63589	H-CARK2-2400-CLL-EL15	43
62718	H-CARK2-1800-CLL-S/S	39	62801	H2CP-1200-S/S	42	63234	HV-1000-SAC-CM-S/S-EL15	44	63599	H-CARK2-1200-CS-S/EL15	44
62719	H-CARK2-2000-CM-S/S	39	62801	H2CP-1200-S/S	47	63235	HV-1000-SAC-CL-S/S-EL15	44	63600	H-CARK2-1200-CM-S/S-EL15	44
62720	H-CARK2-2000-CL-S/S	39	62802	H2CP-1400-S/S	42	63236	HV-1200-SAC-CS-S/S-EL15	44	63601	H-CARK2-1200-CL-S/EL15	44
62721	H-CARK2-2000-CLL-S/S	39	62802	H2CP-1400-S/S	47	63237	HV-1200-SAC-CM-S/S-EL15	44	63602	H-CARK2-1200-CLL-S/EL15	44
62722	H-CARK2-2200-CM-S/S	39	62803	H2CP-1600-S/S	42	63238	HV-1200-SAC-CL-S/S-EL15	44	63603	H-CARK2-1400-CS-S/EL15	44
62723	H-CARK2-2200-CL-S/S	39	62803	H2CP-1600-S/S	47	63239	HV-1400-SAC-CS-S/S-EL15	44	63604	H-CARK2-1400-CM-S/S-EL15	44
62724	H-CARK2-2200-CLL-S/S	39	62804	H2CP-1800-S/S	42	63240	HV-1400-SAC-CM-S/S-EL15	44	63605	H-CARK2-1400-CL-S/EL15	44
62725	H-CARK2-2400-CM-S/S	39	62804	H2CP-1800-S/S	47	63241	HV-1400-SAC-CL-S/S-EL15	44	63606	H-CARK2-1400-CLL-S/S-EL15	44
62726	H-CARK2-2400-CL-S/S	39	62805	H2CP-2000-S/S	42	63242	HV-1600-SAC-CM-S/S-EL15	44	63607	H-CARK2-1600-CM-S/S-EL15	44
62727	H-CARK2-2400-CLL-S/S	39	62805	H2CP-2000-S/S	47	63243	HV-1600-SAC-CL-S/S-EL15	44	63608	H-CARK2-1600-CL-S/EL15	44
62741	H60CSK-G	35	62806	H2CP-2400-S/S	42	63244	HV-1600-SAC-CLL-S/S-EL15	44	63609	H-CARK2-1600-CLL-S/S-EL15	44
62742	HCSTK-60-G	37	62806	H2CP-2400-S/S	47	63245	HV-1800-SAC-CM-S/S-EL15	44	63610	H-CARK2-1800-CM-S/S-EL15	44
62743	H73CSK-G	35	62826	HTF212-S/S	14	63246	HV-1800-SAC-CL-S/S-EL15	44	63611	H-CARK2-1800-CL-S/EL15	44
62743	H73CSK-G	37	62827	HTF218-S/S	14	63247	HV-1800-SAC-CLL-S/S-EL15	44	63612	H-CARK2-1800-CLL-S/S-EL15	44
62743	H73CSK-G	41	62828	HTF224-S/S	14	63421	HV-1200-2SAC-CS-EL15	43	63613	H-CARK2-2000-CM-S/S-EL15	44
62743	H73CSK-G	42	62828	HTF230-S/S	14	63422	HV-1200-2SAC-CM-EL15	43	63614	H-CARK2-2000-CL-S/EL15	44
62743	H73CSK-G	46	62830	HTF236-S/S	14	63423	HV-1200-2SAC-CL-EL15	43	63615	H-CARK2-2000-CLL-S/S-EL15	44
62743	H73CSK-G	47	62831	HTF242-S/S	14	63424	HV-1200-2SAC-CLL-EL15	43	63616	H-CARK2-2200-CM-S/S-EL15	44
62744	H73CSK-G-S/S	35	62832	HTF248-S/S	14	63425	HV-1400-2SAC-CS-EL15	43	63617	H-CARK2-2200-CL-S/EL15	44
62744	H73CSK-G-S/S	37	62833	HTF254-S/S	14	63426	HV-1400-2SAC-CM-EL15	43	63618	H-CARK2-2200-CLL-S/S-EL15	44
62744	H73CSK-G-S/S	41	62834	HTF260-S/S	14	63427	HV-1400-2SAC-CL-EL15	43	63619	H-CARK2-2400-CM-S/S-EL15	44
62744	H73CSK-G-S/S	42	62835	HTF272-S/S	14	63428	HV-1400-2SAC-CLL-EL15	43	63620	H-CARK2-2400-CL-S/EL15	44
62744	H73CSK-G-S/S	46	62836	EZP-LS212-S/S	10	63429	HV-1600-2SAC-CM-EL15	43	63621	H-CARK2-2400-CLL-S/S-EL15	44
62744	H73CSK-G-S/S	47	62837	EZP-LS218-S/S	10	63430	HV-1600-2SAC-CL-EL15	43	63631	H-CARK-600-CS-EL15	43





# INDEX By Item Code

Item Code	Ordering Number	Page #	Item Code	Ordering Number	Page #	Item Code	Ordering Number	Page #	Item Code	Ordering Number	Page #
67586		130	69520	RSA-HD	61	73147	BP1500-1600MF	153	73628	RSA150	37
67587		130	69520	RSA-HD	84	73148	BP1800MF	153	73631	HVPT-S/S	94
67750	YCART-S/S-30/750-SDTC	57	69520	RSA-HD	86	73152	BP450-750MF	153	73631	HVPT-S/S	37
67751	YCART-S/S-36/900-SDTC	57	69521	RC-HD-S/S	61	73153	BP800-1050MF	153	73631	HVPT-S/S	40
67752	YCART-S/S-42/1050-SDTC	57	69521	RC-HD-S/S	84	73154	BP1200-1400MF	153	73631	HVPT-S/S	41
67753	YCART-S/S-48/1200-SDTC	57	69521	RC-HD-S/S	86	73156	PSA150	59	73631	HVPT-S/S	42
67775	HSA200-XL20	34	71053	FLSC-TP	173	73156	PSA150	74	73631	HVPT-S/S	45
67776	RSA150-XL	61	71056	FLSC-TP	173	73156	PSA150	77	73631	HVPT-S/S	46
67776	RSA150-XL	62	71057	FLSC-CP	173	73158	HV1500L	32	73631	HVPT-S/S	47
67776	RSA150-XL	64	71059	FLSC2000-MC	173	73162	RBPCP	163	73637	HV1600M	32
67776	RSA150-XL	66	71061	FLSC2000-CB	173	73163	RBPRET	166	73638	HV1600L	32
67776	RSA150-XL	68	71140	FLSCM-CP	173	73173	HV600M	32	73639	HV1600LL	32
67776	RSA150-XL	70	71148	FLSCM2000	173	73174	HV750M	32	73739	HP1600	37
67776	RSA150-XL	84	72483	CBR-S	158	73175	HV900M	32	73771	HSA8SS-S/S	34
67776	RSA150-XL	90	72484	CBR-M	158	73177	HV1500M	32	73772	HSA8S-S/S	34
67776	RSA150-XL	97	72485	CBR-L	158	73178	HV900L	32	73773	HSA8M-S/S	34
67777	PSA150-XL	59	72486	CBR-XL	158	73179	HV1050L	32	73774	HSA8L-S/S	34
67777	PSA150-XL	77	73003	PP450	59	73180	HV1200L	32	73777	BP600-B	153
68252	RBVP-HD-900	156	73004	PV600	58	73215	HV1500LL	32	73778	BP750-B	153
68253	RBVP-HD-1050	156	73005	PP600	59	73221	PSSS-N	120	73779	BP900-B	153
68254	RBVP-HD-1200	156	73006	PV750	58	73222	PSSS-H	120	73780	BP1050-B	153
68255	RBVP-HD-1350	156	73007	PP750	59	73235	CCKHDT-S/S	59	73781	BP1200-B	153
68256	RBVP-HD-1500	156	73008	PV900	58	73235	CCKHDT-S/S	61	73782	BP1400-B	153
68257	RBVP-HD-1600	156	73009	PP900	59	73235	CCKHDT-S/S	68	73783	BP1500-B	153
68258	RBVP-HD-1800	156	73010	PV1050	58	73301	HBP1200-B	153	73784	BP1600-B	153
68259	RBVP-HD-2000	156	73011	PP1050	59	73302	HBP1400-B	153	73785	BP1800-B	153
68260	RBVP-HD-2200	156	73012	PV1200	58	73303	HBP1500-B	153	73922	HBP-MB-TP	155
68261	RBVP-HD-2400	156	73013	PP1200	59	73304	HBP1600-B	153	74033	HSA8LL-S/S	120
68262	RBVP-HD-2500	156	73014	PS600	120	73306	HBP1800-B	153	74049	PS1800PL	34
68263	RBVP-HD-2600	156	73015	PP1400	59	73307	HBP2000-B	153	74050	PS2000 PL	120
68264	RBVP-HD-2800	156	73016	PP1500	59	73308	HBP2200-B	153	74053	PSN11010	120
68265	RBVP-HD-3000	156	73019	HV450M	32	73309	HBP2400-B	153	74055	BP450-B	153
68266	RBVP-HD-3200	156	73024	PPS6	59	73311	HBP2500-B	153	74057	BP800-B	153
68267	RBVP-SD-600	156	73026	HV450SS	32	73433	PHSC-S/S	59	74100	HW-BC	122
68268	RBVP-SD-750	156	73027	HP450	37	73433	PHSC-S/S	79	74141	HTTS	122
68269	RBVP-SD-900	156	73028	HV450S	32	73433	PHSC-S/S	120	74307	HXF8SS	34
68270	RBVP-SD-1050	156	73029	HP600	37	73434	PSVA	120	74417	STJK	37
68271	RBVP-SD-1200	156	73030	HV600S	32	73435	PV450	58	74417	STJK	37
68272	RBVP-SD-1350	156	73031	HP750	37	73436	PV1400	58	74417	STJK	104
68273	RBVP-SD-1500	156	73032	HV750S	32	73437	PV1500	58	74417	STJK-S/S	105
68274	RBVP-SD-1800	156	73033	HP900	37	73443	HXF1600M	31	74419	STTS	37
68275	RBVP-SD-2000	156	73034	HV900S	32	73444	HXF1600L	31	74419	STTS	104
68276	RBVP-SD-2200	156	73035	HP1050	37	73483	HSHD	37	74420	UTS	37
68277	RBVP-SD-2400	156	73036	HV1050M	32	73483	HSHD	41	74448	UFB18	106
68278	RBVP-SD-2600	156	73037	HP1200	37	73483	HSHD	42	74449	UFB24	106
68279	RBVP-SD-2800	156	73038	HV1200M	32	73483	HSHD	46	74450	UFB30	106
68368	EZRKL-600	141	73045	HV600SS	32	73483	HSHD	47	74451	UFB36	106
68368	EZRKL-600	144	73047	HSA8SS	34	73486	HSA	37	74452	UFB42	106
68369	EZRKL-750	141	73048	HSA8S	34	73489	HSA200	34	74453	UFB48	106
68369	EZRKL-750	144	73049	HSA8M	34	73489	HSA200	37	74454	UFB54	106
68370	EZRKL-900	141	73050	HPS8	37	73489	HSA200	40	74455	UFB60	106
68370	EZRKL-900	144	73053	HV750SS	32	73489	HSA200	41	74456	UFB72	106
68371	EZRKL-1050	141	73054	HMK	37	73489	HSA200	42	74460	UFB84	106
68371	EZRKL-1050	144	73055	HV900SS	32	73489	HSA200	45	74477	HVHD1800L	32
68372	EZRKL-1200	141	73056	HV1050S	32	73489	HSA200	46	74478	HVHD1800LL	32
68372	EZRKL-1200	144	73057	HV1050SS	32	73489	HSA200	47	74490	HBP-SC-TP	155
68373	EZRKL-1350	141	73058	HV1200S	32	73494	HVC-S/S	37	74490	HDCK	37
68373	EZRKL-1350	144	73059	HV1200SS	32	73537	PS1800	120	74502	HDTS	104
68374	EZRKL-1500	141	73063	HSA8L	34	73539	PS2000	120	74504	STKD	37
68374	EZRKL-1500	144	73064	HSA8LL	34	73541	PS750	120	74506	STCK	37
68375	EZRKL-1800	141	73066	HP1500	37	73542	PS900	120	74535	ICT6	59
68375	EZRKL-1800	144	73068	HBRK	37	73543	PS1050	120	74535	ICT6	61
68844		130	73102	BP450	152	73544	PS1200	120	74535	ICT6	62
68867	FCSBC S/S	120	73104	BP600	152	73545	PS1500	120	74535	ICT6	64
69469	HPA1200	128	73106	BP750	152	73546	PS1400	120	74535	ICT6	66
69470	HPA1350	128	73107	BP800	152	73582	PS600PL	120	74535	ICT6	68
69471	HPA1500	128	73108	BP900	152	73583	PS750PL	120	74535	ICT6	70
69472	HPA1600	128	73109	BP450-750-PL	153	73584	PS900PL	120	74535	ICT6	74
69473	HPA1800	128	73110	BP1050	152	73585	PS1050PL	120	74535	ICT6	77
69474	HPA2000	128	73111	BP800-1050-PL	153	73586	PS1200PL	120	74535	ICT6	79
69475	HPA2200	128	73112	BP1200	152	73587	PS1400PL	120	74535	ICT6	81
69476	HPA2400	128	73113	BP1400	152	73588	PS1500PL	120	74535	ICT6	84
69477	HPA2600	128	73114	BP1500	152	73626	PHA	59	74535	ICT6	86
69478	HPA2800	128	73115	BP1600	152	73626	PHA	77	74535	ICT6	90
69479	HPA3000	128	73117	BP1800	152	73628	RSA150	61	74535	ICT6	93
69480	PPA1200	128	73118	BP1200-1400-PL	153	73628	RSA150	62	74539	HVHD2100M	32
69481	PPA1350	128	73119	BP1500-1600-PL	153	73628	RSA150	64	74540	HVHD2100L	32
69482	PPA1500	128	73121	BP1800-PL	153	73628	RSA150	66	74541	HVHD2100LL	32
69483	PPA1650	128	73123	BP-MB	153	73628	RSA150	68	74544	HVHD2400M	32
69484	PPA1800	128	73125	BP-SC	153	73628	RSA150	70	74545	HVHD2400L	32
69485	PPA1950	128	73127	BP-LA	153	73628	RSA150	81	74546	HVHD2400LL	32
69486	PPA2100	128	73138	BP-TB	153	73628	RSA150	84	74547	HPHD2000	37
69487	PPA2250	128	73139	BP-UB	153	73628	RSA150	90	74548	HPHD2400	37
69488	PPA2400	128	73141	BP-TL	153	73628	RSA150	95	74549	HBRKX	37



# INDEX By Item Code

Item Code	Ordering Number	Page #	Item Code	Ordering Number	Page #	Item Code	Ordering Number	Page #	Item Code	Ordering Number	Page #
74550	HDARK	37	74927	MCSK	170	75384	PP750-S/S	59	75521	PMBR-S/S	59
74551	H73BTK	41	74927	MCSK	172	75385	PP900-S/S	59	75521	PMBR-S/S	61
74551	H73BTK	42	74928	MCSKHD	170	75386	PP1050-S/S	59	75521	PMBR-S/S	68
74551	H73BTK	46	74928	MCSKHD	170	75387	PP1200-S/S	59	75521	PMBR-S/S	71
74551	H73BTK	47	74928	MCSKHD	172	75388	PP1400-S/S	59	75521	PMBR-S/S	79
74551	HDMK	37	74930	MCS	170	75389	PP1500-S/S	59	75521	PMBR-S/S	86
74553	PVHD2100	58	74930	MCS	170	75400	RP450-S/S	61	75521	PMBR-S/S	91
74555	PVHD2400	58	74930	MCS	172	75401	RP600-S/S	61	75521	PMBR-S/S	99
74556	PPHD2000	59	74931	MCSHD	170	75402	RP750-S/S	61	75521	PMBR-S/S	114
74557	PPHD2400	59	74931	MCSHD	170	75403	RP900-S/S	61	75531	MFASK	170
74582	HDMRK	37	74931	MCSHD	172	75404	RP1050-S/S	61	75531	MFASK	170
74582	HDMRK	37	74941	SRBK	122	75405	RP1200-S/S	61	75565	HSAS8SSS	34
74597	PPHD1800	59	75266	HXF450S-S/S	31	75406	RP1400-S/S	61	75585	STTS-S/S	37
74598	PVHD1800	58	75267	HXF450M-S/S	31	75407	RP1500-S/S	61	75585	STTS-S/S	105
74601	HPHD1800	37	75268	HXF600S-S/S	31	75419	HVT8-S/S	34	75586	HDT8-S/S	105
74602	HVHD1800M	32	75269	HXF600M-S/S	31	75419	HVT8-S/S	37	75611	EZP1-218	14
74604	RP450	61	75270	HXF750S-S/S	31	75419	HVT8-S/S	40	75612	EZP1-224	14
74605	RP600	61	75271	HXF750M-S/S	31	75419	HVT8-S/S	41	75613	EZP1-230	14
74606	RP750	61	75272	HXF900S-S/S	31	75419	HVT8-S/S	42	75614	EZP1-236	14
74607	RP900	61	75273	HXF900M-S/S	31	75419	HVT8-S/S	45	75615	EZP1-242	14
74608	RP1050	61	75274	HXF900L-S/S	31	75419	HVT8-S/S	46	75616	EZP1-248	14
74609	RP1200	61	75275	HXF1050S-S/S	31	75419	HVT8-S/S	47	75617	EZP1-254	14
74610	RP1400	61	75276	HXF1050M-S/S	31	75420	PVT6-S/S	59	75618	EZP1-260	14
74611	RP1500	61	75277	HXF1050L-S/S	31	75420	PVT6-S/S	79	75619	EZP1P12	16
74613	RPHD1800	61	75278	HXF1200S-S/S	31	75420	PVT6-S/S	120	75619	EZP1P12	16
74614	RPHD2000	61	75279	HXF1200M-S/S	31	75422	HBRK-S/S	37	75620	EZP1P18	20
74615	RPHD2400	61	75280	HXF1200L-S/S	31	75422	HBRK-S/S-60	35	75620	EZP1P18	20
74633	RV450	60	75281	HXF1500M-S/S	31	75423	HARK-S/S	37	75621	EZP1P24	16
74634	RV600	60	75282	HXF1500L-S/S	31	75424	HMK-S/S	37	75621	EZP1P24	20
74635	RV750	60	75283	HXF1600M-S/S	31	75425	STCK-S/S	37	75622	EZP1P30	20
74636	RV900	60	75284	HXF1600L-S/S	31	75426	STJ-S/S	105	75622	EZP1P30	16
74637	RV1050	60	75293	HV450S-S/S	32	75426	STJM-S/S	37	75623	EZP1P36	16
74638	RV1200	60	75294	HV450M-S/S	32	75426	STJM-S/S	37	75623	EZP1P36	20
74639	RV1400	60	75295	HV450L-S/S	32	75427	STKD-S/S	37	75624	EZP1P42	16
74640	RV1500	60	75296	HV600S-S/S	32	75452	PVHD2000	58	75624	EZP1P42	20
74642	RVHD1800	60	75297	HV600M-S/S	32	75463	RVHD2000	60	75625	EZP1P48	16
74643	RVHD2100	60	75298	HV600L-S/S	32	75507	PCB	51	75625	EZP1P48	20
74644	RVHD2400	60	75299	HV750S-S/S	32	75510	PHDCB	55	75626	EZP1P54	16
74659	HXF450S	31	75300	HV750M-S/S	32	75513	PAB	51	75626	EZP1P54	20
74660	HXF450M	31	75301	HV750L-S/S	32	75513	PAB	55	75627	EZP1P60	16
74661	HXF600S	31	75302	HV900S-S/S	32	75513	PAB	59	75627	EZP1P60	20
74662	HXF600M	31	75303	HV900M-S/S	32	75513	PAB	61	75629	CRB16	18
74663	HXF750S	31	75304	HV900L-S/S	32	75513	PAB	68	75630	CRB22	18
74664	HXF750M	31	75305	HV900LL-S/S	32	75513	PAB	77	75631	CRB28	18
74665	HXF900S	31	75306	HV1050S-S/S	32	75513	PAB	84	75632	CRB34	18
74666	HXF900M	31	75307	HV1050M-S/S	32	75513	PAB	97	75633	CRB40	18
74667	HXF900L	31	75308	HV1050L-S/S	32	75513	PAB	114	75634	CRB46	18
74668	HXF1050S	31	75309	HV1050LL-S/S	32	75513	PAB	117	75635	CRB52	18
74669	HXF1050M	31	75310	HV1200S-S/S	32	75515	PAB-S/S	59	75636	CRB58	18
74670	HXF1050L	31	75311	HV1200M-S/S	32	75515	PAB-S/S	61	75637	EZP1MPK	16
74671	HXF1200S	31	75312	HV1200L-S/S	32	75515	PAB-S/S	68	75641	EZP1PL	16
74672	HXF1200M	31	75313	HV1200LL-S/S	32	75515	PAB-S/S	79	75641	EZP1PL	20
74673	HXF1200L	31	75314	HV1500M-S/S	32	75515	PAB-S/S	86	75642	EZP1BP	16
74677	HXF1500M	31	75315	HV1500L-S/S	32	75515	PAB-S/S	99	75642	EZP1BP	20
74678	HXF1500L	31	75316	HV1500LL-S/S	32	75515	PAB-S/S	114	75771	EZP1-272	14
74681	HXFHD1800M	31	75317	HV1600M-S/S	32	75516	PMBL	51	75772	EZP1P72	16
74682	HXFHD1800L	31	75318	HV1600L-S/S	32	75516	PMBL	55	75772	EZP1P72	20
74683	HXFHD2100M	31	75319	HV1600LL-S/S	32	75516	PMBL	59	75773	CRB70	18
74684	HXFHD2100L	31	75323	PV450-S/S	58	75516	PMBL	61	75775	CRB64	18
74685	HXFHD2400M	31	75324	PV600-S/S	58	75516	PMBL	68	75804	MSPP30	109
74686	HXFHD2400L	31	75325	PV750-S/S	58	75516	PMBL	77	75805	MSPP36	109
74689	HXF8S	34	75326	PV900-S/S	58	75516	PMBL	84	75806	MSPP42	109
74690	HXF8M	34	75327	PV1050-S/S	58	75516	PMBL	97	75807	MSPP48	109
74691	HXF8L	34	75328	PV1200-S/S	58	75516	PMBL	114	75808	MSPP54	109
74773	PSSS	59	75329	PV1400-S/S	58	75516	PMBL	117	75809	MSPP60	109
74775	STJM	37	75330	PV1500-S/S	58	75518	PMBL-S/S	59	75811	MSPMPK	24
74775	STJM	37	75341	RV450-S/S	60	75518	PMBL-S/S	61	75820	RMC1-CB	174
74775	STJM	104	75342	RV600-S/S	60	75518	PMBL-S/S	68	75832	RMC1-PP	174
74914	MSR	168	75343	RV750-S/S	60	75518	PMBL-S/S	71	75843	STS-S	55
74914	MSR	170	75344	RV900-S/S	60	75518	PMBL-S/S	79	75843	STS-S	64
74914	MSR	172	75345	RV1050-S/S	60	75518	PMBL-S/S	86	75843	STS-S	66
74916	PMSMK	170	75346	RV1200-S/S	60	75518	PMBL-S/S	91	75843	STS-S	70
74918	MAK	170	75347	RV1400-S/S	60	75518	PMBL-S/S	99	75843	STS-S	91
74919	MAKHD	170	75348	RV1500-S/S	60	75518	PMBL-S/S	114	75843	STS-S	109
74919	MAKHD	170	75373	HP450-S/S	37	75519	PMBR	51	75843	STS-S	114
74921	MORK	170	75374	HP600-S/S	37	75519	PMBR	55	75843	STS-S	110
74921	MORK	170	75375	HP750-S/S	37	75519	PMBR	59	75844	STS-B	35
74923	MCRK	170	75376	HP900-S/S	37	75519	PMBR	61	75844	STS-B	35
74923	MCRK	170	75377	HP1050-S/S	37	75519	PMBR	68	75844	STS-B	55
74923	MCRK	172	75378	HP1200-S/S	37	75519	PMBR	77	75844	STS-B	64
74925	MCB	170	75379	HP1500-S/S	37	75519	PMBR	84	75844	STS-B	66
74925	MCB	170	75380	HP1600-S/S	37	75519	PMBR	97	75844	STS-B	70
74925	MCB	172	75382	PP450-S/S	59	75519	PMBR	114	75844	STS-B	91
74927	MCSK	170	75383	PP600-S/S	59	75519	PMBR	117	75844	STS-B	109

# INDEX By Item Code

Item Code	Ordering Number	Page #	Item Code	Ordering Number	Page #	Item Code	Ordering Number	Page #	Item Code	Ordering Number	Page #
75844	STS-B	114	75968	MHP-CP1800	30	76411	ESBK-B	17	76637	SSTBK-B	91
75845	QMTS-P	16	75978	SSRB	30	76411	ESBK-B EST	17	76637	SSTBK-B	93
75845	QMTS-P	24	75979	HXF2-SS	34	76412	ESS-S	16	76637	SSTBK-B	109
75845	QMTS-P	104	75980	HXF2-S	34	76412	ESS-S	104	76637	SSTBK-B	109
75846	STS-W	64	75981	HXF2-M	34	76413	ESS-B	16	76637	SSTBK-B	114
75846	STS-W	66	75982	HXF2-L	34	76415	RMC1-BPP	174	76637	SSTBK-B	114
75846	STS-W	70	76024	MAPEK	123	76442	CBD-S	158	76638	MHCP-2BC24	30
75846	STS-W	91	76025	MCBK	170	76443	CBD-M	158	76639	MHCP-2BC30	30
75846	STS-W	109	76025	MCBK	170	76444	CBD-L	158	76640	MHCP-2BC36	30
75846	STS-W	114	76025	MCBK	172	76445	CBD-XL	158	76641	MHCP-2BC42	30
75847	STAK	70	76026	MCBKHD	170	76446	DBK-S	158	76642	MHCP-2BC48	30
75847	STAK	70	76026	MCBKHD	170	76447	DBK-M	158	76643	MHCP-2BC54	30
75847	STAK	91	76026	MCBKHD	172	76448	DBK-L	158	76644	MHCP-2BC60	30
75847	STAK	93	76027	HSA200-EL15	34	76449	DBK-XL	158	76645	MHCP-2BC72	30
75847	STAK	109	76027	HSA200-EL15	45	76450	MMP-624	22	76658	HTF212	14
75847	STAK	109	76027	HSA200-EL15	46	76451	MMP-630	22	76659	HTF218	14
75868	MDWS-24	108	76027	HSA200-EL15	47	76452	MMP-636	22	76660	HTF224	14
75869	MDWS-30	108	76069	AWTNCB	30	76453	MMP-642	22	76661	HTF230	14
75870	MDWS-36	108	76069	AWTNCB	36	76454	MMP-648	22	76662	HTF236	14
75871	MDWS-42	108	76071	SSTSMB	123	76455	MMP-654	22	76663	HTF242	14
75872	MDWS-48	108	76072	SSTLMB	123	76456	MMP-660	22	76664	HTF248	14
75873	MDWS-54	108	76074	QMT-P	24	76457	MMP-672	22	76665	HTF254	14
75874	MDWS-60	108	76075	QMT-W	24	76458	MMPCP24	24	76666	HTF260	14
75875	MDWS-72	108	76096	QMTPAK	24	76459	MMPCP30	24	76667	HTF272	14
75883	DWP72	109	76097	QMTBK-P	24	76460	MMPCP36	24	76668	CB128	117
75884	CDWB24	110	76097	QMTBK-P	24	76461	MMPCP42	24	76669	CB24	117
75885	CDWB30	110	76098	QMTBK-W	24	76462	MMPCP48	24	76670	CB30	117
75886	CDWB36	110	76098	QMTBK-W	24	76463	MMPCP54	24	76671	CB36	117
75887	CDWB42	110	76098	QMTBK-W	30	76464	MMPCP60	24	76672	CB42	117
75888	CDWB48	110	76099	QMTPSBK	24	76465	MMPCP72	24	76673	CB48	117
75889	CDWB54	110	76205	RVT6-S/S	61	76466	MMPBPk	24	76674	CB54	117
75890	CDWB60	110	76205	RVT6-S/S	62	76467	HSHD-S/S	37	76675	CB60	117
75891	CDWB72	110	76205	RVT6-S/S	64	76467	HSHD-S/S	41	76692	CPB	117
75892	STAKHD	70	76205	RVT6-S/S	66	76467	HSHD-S/S	42	76695	MSP66	109
75892	STAKHD	70	76205	RVT6-S/S	68	76467	HSHD-S/S	46	76697	TRB78	23
75892	STAKHD	91	76205	RVT6-S/S	70	76467	HSHD-S/S	47	76736	URVB18/450	102
75892	STAKHD	93	76205	RVT6-S/S	86	76472	FLEL-M	134	76736	URVB18/450	102
75892	STAKHD	109	76205	RVT6-S/S	93	76473	FLEL-L	134	76736	URVB18/450	103
75892	STAKHD	109	76205	RVT6-S/S	99	76474	FLELP	134	76736	URVB18/450	103
75892	STAKHD	114	76245	HDMRK-S/S	37	76476	FLTW-M	134	76736	URVB18/450	106
75892	STAKHD	114	76245	HDMRK-S/S	37	76477	FLTW-L	134	76737	URVB24/600	102
75896	PSTA	24	76246	HBRK-S/S-73	35	76478	FLRP	134	76737	URVB24/600	102
75896	PSTA	30	76246	HBRKX-S/S	37	76479	FLCP	134	76737	URVB24/600	103
75897	PTPK	30	76247	HDARK-S/S	37	76481	FLRLB-L	134	76737	URVB24/600	103
75898	PSTS-W	24	76248	HDMK-S/S	37	76482	FLRLB-M	134	76737	URVB24/600	106
75898	PSTS-W	30	76249	RSA	61	76483	QMT-G	24	76738	URVB30/750	102
75898	PSTS-W	104	76249	RSA	84	76484	QMTS-G	24	76738	URVB30/750	102
75899	PSTS-S	30	76250	RC-S/S	61	76484	QMTS-G	104	76738	URVB30/750	103
75899	PSTS-S	35	76250	RC-S/S	86	76485	TRB18	23	76738	URVB30/750	103
75904	AWT	30	76318	CBD-XL-S/S	158	76486	TRB24	23	76738	URVB30/750	106
75904	AWT	36	76337	BP450-S/S	152	76487	TRB30	23	76739	URVB36/900	102
75905	AWTB	30	76338	BP600-S/S	152	76488	TRB36	23	76739	URVB36/900	102
75905	AWTB	36	76339	BP750-S/S	152	76489	TRB42	23	76739	URVB36/900	103
75906	AWTMB	30	76340	BP800-S/S	152	76490	TRB48	23	76739	URVB36/900	103
75906	AWTMB	36	76341	BP900-S/S	152	76491	TRB54	23	76739	URVB36/900	106
75907	AWTA	30	76342	BP1050-S/S	152	76492	TRB60	23	76740	URVB42/1050	102
75907	AWTA	36	76343	BP1200-S/S	152	76493	TRB66	23	76740	URVB42/1050	102
75908	AWTCB	30	76344	BP1400-S/S	152	76494	TRB72	23	76740	URVB42/1050	103
75908	AWTCB	36	76345	BP1500-S/S	152	76540	QMTBK-G	24	76740	URVB42/1050	103
75909	AWTHK	30	76346	BP1600-S/S	152	76540	QMTBK-G	24	76740	URVB42/1050	106
75909	AWTHK	36	76347	BP1800-S/S	152	76558	RMC-FS	174	76741	URVB48/1200	102
75929	MHCP-24S	28	76375	AWT-1S	30	76559	RMC2-FSAPK	174	76741	URVB48/1200	102
75930	MHCP-30S	28	76375	AWT-1S	36	76593	CRB-HT10	18	76741	URVB48/1200	103
75931	MHCP-36S	28	76392	MHP-EP	24	76594	CRB-HT16	18	76741	URVB48/1200	103
75932	MHCP-42S	28	76392	MHP-EP	30	76595	CRB-HT22	18	76741	URVB48/1200	106
75933	MHCP-48S	28	76392	MHP-EP	42	76596	CRB-HT28	18	76742	URVB54/1350	102
75934	MHCP-54S	28	76392	MHP-EP	47	76597	CRB-HT34	18	76742	URVB54/1350	102
75935	MHCP-60S	28	76392	MHP-EP	76	76598	CRB-HT40	18	76742	URVB54/1350	103
75936	MHCP-72S	28	76392	MHP-EP	83	76599	CRB-HT46	18	76742	URVB54/1350	103
75937	MHCP-24A	28	76392	MHP-EP	90	76600	CRB-HT52	18	76742	URVB54/1350	106
75938	MHCP-30A	28	76392	MHP-EP	97	76601	CRB-HT58	18	76743	URVB60/1500	102
75939	MHCP-36A	28	76393	MHCP-CH	30	76602	CRB-HT64	18	76743	URVB60/1500	102
75940	MHCP-42A	28	76394	MHCP-BS	30	76603	CRB-HT70	18	76743	URVB60/1500	103
75941	MHCP-48A	28	76406	ESTAK	16	76636	SSTBK-W	70	76743	URVB60/1500	103
75942	MHCP-54A	28	76406	ESTAK	104	76636	SSTBK-W	70	76743	URVB60/1500	106
75943	MHCP-60A	28	76406	ESTAK-EST	35	76636	SSTBK-W	91	76744	URVB72/1800	102
75944	MHCP-72A	28	76406	HARK	37	76636	SSTBK-W	93	76744	URVB72/1800	102
75961	MHP-CP600	30	76406	HARK	104	76636	SSTBK-W	109	76744	URVB72/1800	103
75962	MHP-CP750	30	76407	ESPSBK	16	76636	SSTBK-W	109	76744	URVB72/1800	103
75963	MHP-CP900	30	76408	ESPBK	16	76636	SSTBK-W	114	76744	URVB72/1800	106
75964	MHP-CP1050	30	76409	ESPRK	16	76636	SSTBK-W	114	76745	URVB84/2100	102
75965	MHP-CP1200	30	76410	ESBK-PS	16	76636	SSTBK-W	110	76745	URVB84/2100	102
75966	MHP-CP1400	30	76410	ESBK-PS	17	76637	SSTBK-B	70	76745	URVB84/2100	103
75967	MHP-CP1500	30	76411	ESBK-B	16	76637	SSTBK-B	70	76745	URVB84/2100	103

# INDEX By Item Code

Item Code	Ordering Number	Page #	Item Code	Ordering Number	Page #	Item Code	Ordering Number	Page #	Item Code	Ordering Number	Page #
76745	URVB84/2100	106	76935	ISABK	150	77144	CLSF6-212	10	77346	USP56/1400-S/S	105
76788	ABU	104	76936	IMK	147	77145	CLSF6-218	10	77347	USP60/1500-S/S	105
76788	ABU	104	76936	IMK	148	77146	CLSF6-224	10	77348	USP64/1600-S/S	105
76788	ABU	105	76936	IMK	149	77147	CLSF6-230	10	77349	USP72/1800-S/S	105
76788	ABU	105	76937	IEA42-60D	150	77148	CLSF6-236	10	77350	USP80/2000-S/S	105
76790	USPK	104	76938	IEA72-96D	150	77149	CLSF6-242	10	77351	USP84/2100-S/S	105
76798	MMP-684	22	76939	HW-IMPB	151	77150	CLSF6-248	10	77352	USP88/2200-S/S	105
76800	MHCP-84S	28	76942	CDWB84	110	77151	CLSF6-254	10	77357	MMKU-SS	105
76801	MHCP-84A	28	76950	OIBBK	151	77152	CLSF6-260	10	77358	MMKUHD-SS	105
76806	MDWS-84	108	76965	IB4-1U	151	77250	FL-PKIT-ML	134	77364	HARK-S/S	105
76808	MMPCP84	24	76966	IB5-1U	151	77251	FL-PKIT-XL	134	77365	LS-SP	12
76811	MHP-CP2100	30	76979	FLM	134	77259	UTV450J-S/S	103	77366	LSTMPK	12
76812	MHCP-2BC84	30	76980	FLL	134	77260	UTV600J-S/S	103	77367	LSTPB-RK	12
76815	DWP84	109	76983	FLXL	134	77261	UTV750J-S/S	103	77367	LSTPB-RK	12
76816	DRXL-24-420	147	76984	FLVRL-XL	134	77262	UTV900J-S/S	103	77384	EZPTBT	20
76817	DRXL-30-420	147	76985	FLTW-XL	134	77263	UTV1050J-S/S	103	77385	EZPTBTHD	20
76818	DRXL-36-420	147	76986	FLELK-XL	134	77264	UTV1200J-S/S	103	77387	SPG-CVR-A	21
76819	DRXL-42-420	147	77031	CSTAK	91	77265	UTV1350J-S/S	103	77387	SPG-CVR-A	73
76820	DRXL-48-420	147	77031	CSTAK	93	77266	UTV1400J-S/S	103	77387	SPG-CVR-A	101
76821	DRXL-54-420	147	77037	CSTBK	91	77267	UTV1500J-S/S	103	77388	SPG-CVR-B	21
76822	DRXL-60-420	147	77037	CSTBK	93	77268	UTV1600J-S/S	103	77388	SPG-CVR-B	73
76823	DRXL-72-420	147	77047	TRB84	23	77269	UTV1800J-S/S	103	77388	SPG-CVR-B	101
76824	DRXL-24-520	147	77048	TRB90	23	77270	UTV2000J-S/S	103	77389	SPG-CVR-C	21
76825	DRXL-30-520	147	77052	SACSK	91	77271	UTV2100J-S/S	103	77389	SPG-CVR-C	73
76826	DRXL-36-520	147	77052	SACSK	93	77272	UTV2200J-S/S	103	77389	SPG-CVR-C	101
76827	DRXL-42-520	147	77065	SACSRC	91	77283	UTV450-J	103	77390	SPG-CVR-D	21
76828	DRXL-48-520	147	77065	SACSRC	93	77284	UTV600-J	103	77390	SPG-CVR-D	73
76829	DRXL-54-520	147	77070	LSP12	12	77285	UTV750-J	103	77390	SPG-CVR-D	101
76830	DRXL-60-520	147	77071	LSP18	12	77286	UTV900-J	103	77391	SPG-CVR-E	21
76831	DRXL-72-520	147	77072	LSP24	12	77287	UTV1050-J	103	77391	SPG-CVR-E	73
76832	DRXL-24-435	147	77073	LSP30	12	77288	UTV1200-J	103	77391	SPG-CVR-E	101
76833	DRXL-30-435	147	77074	LSP36	12	77289	UTV1350-J	103	77392	SPG-CVR-F	21
76834	DRXL-36-435	147	77075	LSP42	12	77290	UTV1400-J	103	77392	SPG-CVR-F	73
76835	DRXL-42-435	147	77076	LSP48	12	77291	UTV1500-J	103	77392	SPG-CVR-F	101
76836	DRXL-48-435	147	77077	LSP54	12	77292	UTV1600-J	103	77393	SPG-CVR-F	21
76837	DRXL-54-435	147	77078	LSP60	12	77293	UTV1800-J	103	77393	SPG-CVR-G	73
76838	DRXL-60-435	147	77079	LSP12-S/S	12	77294	UTV2000-J	103	77393	SPG-CVR-G	101
76839	DRXL-72-435	147	77080	LSP18-S/S	12	77295	UTV2100-J	103	77411	UTV2400	102
76840	DRXL-24-535	147	77081	LSP24-S/S	12	77296	UTV2200-J	103	77412	UTV2500	102
76841	DRXL-30-535	147	77082	LSP30-S/S	12	77297	UTV450	102	77413	UTV2400-J	103
76842	DRXL-36-535	147	77083	LSP36-S/S	12	77298	UTV600	102	77414	UTV2500-J	103
76843	DRXL-42-535	147	77084	LSP42-S/S	12	77299	UTV750	102	77417	UTV2400J-S/S	103
76844	DRXL-48-535	147	77085	LSP48-S/S	12	77300	UTV900	102	77418	UTV2500J-S/S	103
76845	DRXL-54-535	147	77086	LSP54-S/S	12	77301	UTV1050	102	77419	USP94/2400-S/S	105
76846	DRXL-60-535	147	77087	LSP60-S/S	12	77302	UTV1200	102	77420	USP98/2500-S/S	105
76847	DRXL-72-535	147	77088	CRB-LS10	13	77303	UTV1350	102	77421	URVB94/2400	102
76912	DRXD-42-520	150	77089	CRB-LS16	13	77304	UTV1400	102	77421	URVB94/2400	102
76913	DRXD-48-520	150	77090	CRB-LS22	13	77305	UTV1500	102	77421	URVB94/2400	103
76914	DRXD-54-520	150	77091	CRB-LS28	13	77306	UTV1600	102	77421	URVB94/2400	106
76915	DRXD-60-520	150	77092	CRB-LS34	13	77307	UTV1800	102	77421	URVB94/2400	106
76916	DRXD-72-520	150	77093	CRB-LS40	13	77308	UTV2000	102	77422	URVB98/2500	102
76917	DRXD-84-520	150	77094	CRB-LS46	13	77309	UTV2100	102	77422	URVB98/2500	102
76918	DRXD-96-520	150	77095	CRB-LS52	13	77310	UTV2200	102	77422	URVB98/2500	103
76919	DRXD-42-535	150	77096	CRB-LS58	13	77314	URVB56/1400	102	77422	URVB98/2500	103
76920	DRXD-48-535	150	77097	CRB-LS10W	13	77314	URVB56/1400	102	77422	URVB98/2500	106
76921	DRXD-54-535	150	77098	CRB-LS16W	13	77314	URVB56/1400	103	77424	MMP-624-S/S	22
76922	DRXD-60-535	150	77099	CRB-LS22W	13	77314	URVB56/1400	103	77425	MMP-630-S/S	22
76923	DRXD-72-535	150	77100	CRB-LS28W	13	77314	URVB56/1400	106	77426	MMP-636-S/S	22
76924	DRXD-84-535	150	77101	CRB-LS34W	13	77315	URVB64/1600	102	77427	MMP-642-S/S	22
76925	DRXD-96-535	150	77102	CRB-LS40W	13	77315	URVB64/1600	102	77428	MMP-648-S/S	22
76926	IB4	139	77103	CRB-LS46W	13	77315	URVB64/1600	103	77429	MMP-654-S/S	22
76926	IB4	141	77104	CRB-LS52W	13	77315	URVB64/1600	103	77430	MMP-660-S/S	22
76926	IB4	144	77105	CRB-LS58W	13	77315	URVB64/1600	106	77431	MMP-672-S/S	22
76926	IB4	147	77114	LS-BP	12	77316	URVB88/2200	102	77432	MMP-684-S/S	22
76926	IB4	148	77115	LS-BP-S/S	12	77316	URVB88/2200	102	77442	PSTA-S/S	24
76926	IB4	149	77117	LS-SW	12	77316	URVB88/2200	103	77443	TEN-LOCK-KIT	21
76927	IB5	139	77118	LS-SS	12	77316	URVB88/2200	103	77443	TEN-LOCK-KIT	73
76927	IB5	141	77120	LST-TAK	12	77316	URVB88/2200	106	77443	TEN-LOCK-KIT	101
76927	IB5	144	77120	LST-TAK	12	77320	URVB80/2000	102	77450	QMTS-P-S/S	17
76927	IB5	147	77121	LST-P	12	77320	URVB80/2000	102	77450	QMTS-P-S/S	24
76927	IB5	148	77122	LST-W	12	77320	URVB80/2000	103	77450	QMTS-P-SS	105
76927	IB5	149	77123	LST-S	12	77320	URVB80/2000	103	77451	QMTS-W-S/S	17
76927	IB5	150	77124	LST-B-S/S	12	77320	URVB80/2000	106	77451	QMTS-W-SS	105
76928	IBBK	147	77125	LST-W-S/S	12	77324	MMKU	104	77451	QSTS-W-S/S	24
76928	IBBK	148	77126	LST-W-S/S-2	12	77327	MMKUHD	104	77452	QMTS-G-S/S	17
76928	IBBK	149	77127	EZP-LS212	10	77329	HDARK	104	77452	QMTS-G-S/S	24
76928	IBBK	150	77128	EZP-LS218	10	77331	HDARK-S/S	105	77452	QMTS-G-SS	105
76929	IBS-L4	147	77129	EZP-LS224	10	77339	USP18/450-S/S	105	77473	MSP30-S/S	109
76930	IBS-L5	147	77130	EZP-LS230	10	77340	USP24/600-S/S	105	77474	MSP36-S/S	109
76931	IBS-M4	148	77131	EZP-LS236	10	77341	USP30/750-S/S	105	77475	MSP42-S/S	109
76932	IBS-M5	148	77132	EZP-LS242	10	77342	USP36/900-S/S	105	77476	MSP48-S/S	109
76933	IBS-H4	149	77133	EZP-LS248	10	77343	USP42/1050-S/S	105	77477	MSP54-S/S	109
76934	IBS-DH5	149	77134	EZP-LS254	10	77344	USP48/1200-S/S	105	77478	MSP60-S/S	109
76934	IBS-DH5	150	77135	EZP-LS260	10	77345	USP54/1350-S/S	105	77479	MSP66-S/S	109

# INDEX By Item Code

Item Code	Ordering Number	Page #	Item Code	Ordering Number	Page #	Item Code	Ordering Number	Page #	Item Code	Ordering Number	Page #
77481	MHS-600BT	67	77516	MHS-P2400S/S	68	77632	STS-B-S/S	35	77789	MHS-600FPV	69
77482	MHS-750BT	67	77516	MHS-P2400S/S*	70	77632	STS-B-S/S	64	77790	MHS-750FPV	69
77483	MHS-900BT	67	77518	HXF8S-Blue	34	77632	STS-B-S/S	66	77791	MHS-900FPV	69
77484	MHS-1050BT	67	77519	HXF8S-Blue	34	77632	STS-B-S/S	70	77792	MHS-1050FPV	69
77485	MHS-1350BT	67	77520	HXF8M-Blue	34	77632	STS-B-S/S	93	77793	MHS-1350FPV	69
77486	MHS-1500BT	67	77521	HXF8L-Blue	34	77632	STS-B-S/S	109	77794	MHS-1350FPV	69
77487	MHS-1800BT	67	77525	MHS-1200BT	67	77632	STS-B-S/S	114	77795	MHS-1500FPV	69
77488	MHS-2100BT	67	77526	MHS-1200BTV-S/S	67	77633	SSTHDPM2-S/S	114	77796	MHS-1800FPV	69
77489	MHS-2400BT	67	77527	MHS-P1200	66	77633	STHDPM2-S/S	70	77797	MHS-2100FPV	69
77490	MHS-600BTV-S/S	67	77527	MHS-P1200	68	77633	STHDPM2-S/S	93	77798	MHS-2400FPV	69
77491	MHS-750BTV-S/S	67	77527	MHS-P1200*	64	77633	STHDPM2-S/S	109	77799	MHS-600FPV-S/S	69
77492	MHS-900BTV-S/S	67	77527	MHS-P1200*	70	77634	STHDMK2-S/S	70	77800	MHS-750FPV-S/S	69
77493	MHS-1050BTV-S/S	67	77528	MHS-P1200S/S	66	77634	STHDMK2-S/S	93	77801	MHS-900FPV-S/S	69
77494	MHS-1350BTV-S/S	67	77528	MHS-P1200S/S	68	77634	STHDMK2-S/S	109	77802	MHS-1050FPV-S/S	69
77495	MHS-1500BTV-S/S	67	77528	MHS-P1200S/S*	64	77635	STGK2	70	77803	MHS-1200FPV-S/S	69
77496	MHS-1800BTV-S/S	67	77528	MHS-P1200S/S*	70	77635	STGK2	70	77804	MHS-1350FPV-S/S	69
77497	MHS-2100BTV-S/S	67	77529	ISABK-LMH	147	77635	STGK2	91	77805	MHS-1500FPV-S/S	69
77498	MHS-2400BTV-S/S	67	77529	ISABK-LMH	148	77635	STGK2	93	77806	MHS-1800FPV-S/S	69
77499	MHS-P600	66	77529	ISABK-LMH	149	77635	STGK2	109	77807	MHS-2100FPV-S/S	69
77499	MHS-P600	68	77531	MRB18	27	77635	STGK2	109	77808	MHS-2400FPV-S/S	69
77499	MHS-P600*	64	77532	MRB24	27	77635	STGK2	114	77866	SAC2-TIP-TL	77
77499	MHS-P600*	70	77533	MRB30	27	77635	STGK2	114	77866	SAC2-TIP-TL	79
77500	MHS-P750	66	77534	MRB36	27	77664	PTS-18R	165	77866	SAC2-TIP-TL	84
77500	MHS-P750	68	77535	MRB42	27	77665	PTS-24R	165	77866	SAC2-TIP-TL	86
77500	MHS-P750*	64	77536	MRB48	27	77666	PTS-30R	165	77866	SAC2-TIP-TL	91
77500	MHS-P750*	70	77537	MRB54	27	77667	PTS-36R	165	77866	SAC2-TIP-TL	93
77501	MHS-P900	66	77538	MRB60	27	77668	PTS-42R	165	77866	SAC2-TIP-TL	97
77501	MHS-P900	68	77539	MRB66	27	77669	PTS-48R	165	77866	SAC2-TIP-TL	99
77501	MHS-P900*	64	77540	MRB72	27	77670	PTS-54R	165	77868	SSTHDPM	70
77501	MHS-P900*	70	77541	MRB78	27	77671	PTS-60R	165	77868	SSTHDPM	91
77502	MHS-P1050	66	77542	MRB84	27	77672	PTS-72R	165	77868	SSTHDPM	109
77502	MHS-P1050	68	77543	MRB90	27	77680	PTS-RR21	165	77868	SSTHDPM	114
77502	MHS-P1050*	64	77544	MRB96	27	77681	PTS-RR27	165	77869	CSTHDPM	91
77502	MHS-P1050*	70	77545	MRB102	27	77682	PTS-RR33	165	77871	CSTHDMK	91
77503	MHS-P1350	66	77546	MRB108	27	77683	PTS-RR39	165	77882	SACRKN	41
77503	MHS-P1350	68	77547	MRB114	27	77684	PTS-RR45	165	77882	SACRKN	77
77503	MHS-P1350*	64	77548	SHIM-KITL	147	77685	PTS-RR51	165	77882	SACRKN	79
77503	MHS-P1350*	70	77549	SHIM-KITM	148	77686	PTS-RR57	165	77882	SACRKN	84
77504	MHS-P1500	66	77550	SHIM-KITH	149	77687	PTS-RR63	165	77882	SACRKN	86
77504	MHS-P1500	68	77552	CRB-LS16HT	13	77689	PTS-RR75	165	77882	SACRKN	93
77504	MHS-P1500*	64	77553	CRB-LS22HT	13	77691	PTS-SR	166	77882	SACRKN	91
77504	MHS-P1500*	70	77554	CRB-LS28HT	13	77692	PTS-HDSR	166	77882	SACRKN	97
77505	MHS-P1800	66	77555	CRB-LS34HT	13	77693	PTS-ABK	166	77882	SACRKN	91
77505	MHS-P1800	68	77556	CRB-LS40HT	13	77694	PTS-SAK	166	77883	SACRH	49
77505	MHS-P1800*	64	77557	CRB-LS46HT	13	77696	PTS-IBK	166	77883	SACRH	77
77505	MHS-P1800*	70	77558	CRB-LS52HT	13	77697	PTS-HIBK	166	77883	SACRH	81
77506	MHS-P2100	66	77559	CRB-LS58HT	13	77698	PTS-PS	166	77883	SACRH	94
77506	MHS-P2100	68	77582	MSPMPK-S/S	24	77699	PTS-PA	166	77883	SACRH	97
77506	MHS-P2100*	70	77583	MSPBPK-S/S	17	77700	PTS-MBK	166	77884	SACRHL	41
77507	MHS-P2400	66	77584	QMT-P-S/S	24	77701	PTS-MBKUG	166	77884	SACRHL	77
77507	MHS-P2400	68	77585	QMT-W-S/S	24	77702	PTS-EBK	166	77884	SACRHL	84
77507	MHS-P2400*	70	77586	QMT-G-S/S	24	77703	MHP-624	26	77884	SACRHL	91
77508	MHS-P600S/S	66	77587	QMTPAK-S/S	24	77704	MHP-630	26	77884	SACRHL	97
77508	MHS-P600S/S	68	77588	QMTPSBK-S/S	24	77705	MHP-636	26	77885	SACKRP	41
77508	MHS-P600S/S*	64	77590	MMPCP24-S/S	24	77706	MHP-642	26	77885	SACKRP	77
77508	MHS-P600S/S*	70	77591	MMPCP30-S/S	24	77707	MHP-648	26	77885	SACKRP	84
77509	MHS-P750S/S	66	77592	MMPCP36-S/S	24	77708	MHP-654	26	77885	SACKRP	91
77509	MHS-P750S/S	68	77593	MMPCP42-S/S	24	77709	MHP-660	26	77885	SACKRP	97
77509	MHS-P750S/S*	64	77594	MMPCP48-S/S	24	77710	MHP-672	26	77886	SACRKT	77
77509	MHS-P750S/S*	70	77595	MMPCP54-S/S	24	77711	MHP-684	26	77886	SACRKT	84
77510	MHS-P900S/S	66	77596	MMPCP60-S/S	24	77712	MHP-696	26	77886	SACRKT	91
77510	MHS-P900S/S	68	77597	MMPCP72-S/S	24	77723	PST2-W	30	77886	SACRKT	97
77510	MHS-P900S/S*	64	77598	MMPCP84-S/S	24	77724	PST2-S	30	77887	SACPL-24/600	76
77510	MHS-P900S/S*	70	77599	MHP-EP-S/S	24	77727	PMB	30	77887	SACPL-24/600	83
77511	MHS-P1050S/S	66	77599	MHP-EP-S/S	42	77729	FLCK	134	77887	SACPL-24/600	90
77511	MHS-P1050S/S	68	77599	MHP-EP-S/S	47	77741	SPG-CVR-H	21	77887	SACPL-24/600	97
77511	MHS-P1050S/S*	64	77599	MHP-EP-S/S	78	77741	SPG-CVR-H	73	77888	SACPL-30/750	76
77511	MHS-P1050S/S*	70	77599	MHP-EP-S/S	85	77741	SPG-CVR-H	101	77888	SACPL-30/750	83
77512	MHS-P1350S/S	66	77599	MHP-EP-S/S	92	77742	CTS-W	91	77888	SACPL-30/750	97
77512	MHS-P1350S/S	68	77599	MHP-EP-S/S	98	77743	CTS-S	91	77888	SACPL-30/750	90
77512	MHS-P1350S/S*	64	77600	MMPBPK-S/S	24	77743	CTS-S	91	77889	SACPL-36/900	76
77512	MHS-P1350S/S*	70	77630	STS-W-S/S	64	77744	CTS-B	91	77889	SACPL-36/900	83
77513	MHS-P1500S/S	66	77630	STS-W-S/S	66	77745	CTS-G	91	77889	SACPL-36/900	90
77513	MHS-P1500S/S	68	77630	STS-W-S/S	70	77746	EZP-LS212HT	10	77889	SACPL-36/900	97
77513	MHS-P1500S/S*	64	77630	STS-W-S/S	93	77747	EZP-LS218HT	10	77890	SACPL-42/1050	76
77513	MHS-P1500S/S*	70	77630	STS-W-S/S	109	77748	EZP-LS224HT	10	77890	SACPL-42/1050	83
77514	MHS-P1800S/S	66	77630	STS-W-S/S	114	77749	EZP-LS230HT	10	77890	SACPL-42/1050	90
77514	MHS-P1800S/S	68	77631	STS-S-S/S	64	77750	EZP-LS236HT	10	77890	SACPL-42/1050	97
77514	MHS-P1800S/S*	64	77631	STS-S-S/S	66	77751	EZP-LS242HT	10	77891	SACPL-48/1200	76
77514	MHS-P1800S/S*	70	77631	STS-S-S/S	70	77752	EZP-LS248HT	10	77891	SACPL-48/1200	83
77515	MHS-P2100S/S	66	77631	STS-S-S/S	93	77753	EZP-LS254HT	10	77891	SACPL-48/1200	90
77515	MHS-P2100S/S	68	77631	STS-S-S/S	109	77754	EZP-LS260HT	10	77891	SACPL-48/1200	97
77515	MHS-P2100S/S*	66	77631	STS-S-S/S	114	77755	PTS-RHSAA	166	77892	SACPL-54/1350	76
77516	MHS-P2400S/S	66	77632	STS-B-S/S	35	77756	PTS-LHSAA	166	77892	SACPL-54/1350	83

# INDEX By Item Code

Item Code	Ordering Number	Page #	Item Code	Ordering Number	Page #	Item Code	Ordering Number	Page #	Item Code	Ordering Number	Page #
77892	SACPL-54/1350	90	78019	MHS-3000BTV-2SAC	95	78326	MHS-2100BTV-2SAC-S/S	95	78380	SACPL2-72/1800-S/S	98
77892	SACPL-54/1350	97	78020	PV600-SAC	74	78327	MHS-2400BTV-2SAC-S/S	95	78381	SACPL2-84/2100-S/S	78
77893	SACPL-60/1500	76	78021	PV750-SAC	74	78328	MHS-3000BTV-2SAC-S/S	95	78381	SACPL2-84/2100-S/S	85
77893	SACPL-60/1500	83	78022	PV900-SAC	74	78329	PV600-SAC-S/S	74	78381	SACPL2-84/2100-S/S	92
77893	SACPL-60/1500	90	78023	PV1050-SAC	74	78330	PV750-SAC-S/S	74	78381	SACPL2-84/2100-S/S	98
77893	SACPL-60/1500	97	78024	PV1200-SAC	74	78331	PV900-SAC-S/S	74	78382	SACPL2-96/2400-S/S	78
77894	SACPL-72/1800	76	78025	PV1350-SAC	74	78332	PV1050-SAC-S/S	74	78382	SACPL2-96/2400-S/S	85
77894	SACPL-72/1800	83	78026	PV1500-SAC	74	78333	PV1200-SAC-S/S	74	78382	SACPL2-96/2400-S/S	92
77894	SACPL-72/1800	90	78027	PV1800-SAC	74	78334	PV1350-SAC-S/S	74	78382	SACPL2-96/2400-S/S	98
77894	SACPL-72/1800	97	78028	PV1500-2SAC	74	78335	PV1500-SAC-S/S	74	78383	SACPL2-120/3000-S/S	78
77895	SACPL2-60/1500	76	78029	PV1800-2SAC	74	78336	PV1800-SAC-S/S	74	78383	SACPL2-120/3000-S/S	85
77895	SACPL2-60/1500	83	78030	PV2100-2SAC	74	78337	PV1500-2SAC-S/S	74	78383	SACPL2-120/3000-S/S	92
77895	SACPL2-60/1500	90	78031	PV2400-2SAC	74	78338	PV1800-2SAC-S/S	74	78383	SACPL2-120/3000-S/S	98
77895	SACPL2-60/1500	97	78032	PV3000-2SAC	74	78339	PV2100-2SAC-S/S	74	78384	CSTHDMK-S/S	93
77896	SACPL2-72/1800	76	78033	RV600-SAC	81	78340	PV2400-2SAC-S/S	74	78385	CTS-W-S/S	93
77896	SACPL2-72/1800	83	78034	RV750-SAC	81	78341	PV3000-2SAC-S/S	74	78386	CTS-S-S/S	74
77896	SACPL2-72/1800	90	78035	RV900-SAC	81	78342	RV600-SAC-S/S	81	78387	CTS-B-S/S	12
77896	SACPL2-72/1800	97	78036	RV1050-SAC	81	78343	RV750-SAC-S/S	81	78387	CTS-B-S/S	93
77897	SACPL2-84/2100	76	78037	RV1200-SAC	81	78344	RV900-SAC-S/S	81	78388	CTS-G-S/S	93
77897	SACPL2-84/2100	83	78038	RV1350-SAC	81	78345	RV1050-SAC-S/S	81	78389	CSTHDPIM-S/S	93
77897	SACPL2-84/2100	90	78039	RV1500-SAC	81	78346	RV1200-SAC-S/S	81	78390	CSTHDM-W-S/S	93
77897	SACPL2-84/2100	97	78040	RV1800-SAC	81	78347	RV1350-SAC-S/S	81	78391	CSTHDM-S-S/S	93
77898	SACPL2-96/2400	76	78041	RV1500-2SAC	81	78348	RV1500-SAC-S/S	81	78392	CSTHDM-B-S/S	93
77898	SACPL2-96/2400	83	78042	RV1800-2SAC	81	78349	RV1800-SAC-S/S	81	78393	CSTHDM-G-S/S	93
77898	SACPL2-96/2400	90	78043	RV2100-2SAC	81	78350	RV1500-2SAC-S/S	81	78394	SSTHDM-W-S/S	93
77898	SACPL2-96/2400	97	78044	RV2400-2SAC	81	78351	RV1800-2SAC-S/S	81	78394	SSTHDM-W-S/S	109
77899	SACPL2-120/3000	76	78045	RV3000-2SAC	81	78352	RV2100-2SAC-S/S	81	78395	SSTHDM-S-S/S	70
77899	SACPL2-120/3000	83	78080	P-CARK-V24/600	75	78353	RV2400-2SAC-S/S	81	78395	SSTHDM-S-S/S	93
77899	SACPL2-120/3000	90	78081	P-CARK-V30/750	75	78354	RV3000-2SAC-S/S	81	78395	SSTHDM-S-S/S	109
77899	SACPL2-120/3000	97	78082	P-CARK-V36/900	75	78355	PCAP-24/600-S/S	79	78396	SSTHDM-B-S/S	70
77913	PCAP-24/600	77	78083	P-CARK-V42/1050	75	78356	PCAP-30/750-S/S	79	78396	SSTHDM-B-S/S	93
77914	PCAP-30/750	77	78084	P-CARK-V48/1200	75	78357	PCAP-36/900-S/S	79	78396	SSTHDM-B-S/S	109
77915	PCAP-36/900	77	78085	P-CARK-V54/1350	75	78358	PCAP-42/1050-S/S	79	78397	SACRH-S/S	79
77916	PCAP-42/1050	77	78086	P-CARK-V60/1500	75	78359	PCAP-48/1200-S/S	79	78397	SACRH-S/S	86
77917	PCAP-48/1200	77	78087	P-CARK-V72/1800	75	78360	PCAP-54/1350-S/S	79	78397	SACRH-S/S	99
77918	PCAP-54/1350	77	78093	P-CARK2-V60/1500	75	78361	PCAP-60/1500-S/S	79	78398	SACRHL-S/S	79
77919	PCAP-60/1500	77	78094	P-CARK2-V72/1800	75	78362	PCAP-72/1800-S/S	79	78398	SACRHL-S/S	86
77920	PCAP-72/1800	77	78095	P-CARK2-V84/2100	75	78363	RCAP-24/600-S/S	86	78399	SACRHL-S/S	93
77921	RCAP-24/600	84	78096	P-CARK2-V96/2400	75	78364	RCAP-30/750-S/S	86	78399	SACKRP-S/S	79
77922	RCAP-30/750	84	78097	P-CARK2-V120/3000	75	78365	RCAP-36/900-S/S	86	78399	SACKRP-S/S	86
77923	RCAP-36/900	84	78106	R-CARK-V24/600	82	78366	RCAP-42/1050-S/S	86	78399	SACKRP-S/S	93
77924	RCAP-42/1050	84	78107	R-CARK-V30/750	82	78367	RCAP-48/1200-S/S	86	78399	SACKRP-S/S	99
77925	RCAP-48/1200	84	78108	R-CARK-V36/900	82	78368	RCAP-54/1350-S/S	86	78401	SACRKT-S/S	79
77926	RCAP-54/1350	84	78109	R-CARK-V42/1050	82	78369	RCAP-60/1500-S/S	86	78401	SACRKT-S/S	86
77927	RCAP-60/1500	84	78110	R-CARK-V48/1200	82	78370	RCAP-72/1800-S/S	86	78401	SACRKT-S/S	93
77928	RCAP-72/1800	84	78111	R-CARK-V54/1350	82	78371	SACPL-24/600-S/S	78	78401	SACRKT-S/S	99
77937	MHS-CARK-V24/600	89	78112	R-CARK-V60/1500	82	78371	SACPL-24/600-S/S	92	78456	SSFRB	30
77937	MHS-CARK-V24/600	96	78113	R-CARK-V72/1800	82	78371	SACPL-24/600-S/S	98	78462	LSTMPK2-S/S	12
77938	MHS-CARK-V30/750	89	78119	R-CARK2-V60/1500	82	78371	SACPL-24/600-S/S	98	78472	CRB-WV16	18
77938	MHS-CARK-V30/750	96	78120	R-CARK2-V72/1800	82	78372	SACPL-30/750-S/S	78	78473	CRB-WV22	18
77939	MHS-CARK-V36/900	89	78121	R-CARK2-V84/2100	82	78372	SACPL-30/750-S/S	85	78474	CRB-WV28	18
77939	MHS-CARK-V36/900	96	78122	R-CARK2-V96/2400	82	78372	SACPL-30/750-S/S	92	78475	CRB-WV34	18
77940	MHS-CARK-V42/1050	89	78123	R-CARK2-V120/3000	82	78372	SACPL-30/750-S/S	98	78476	CRB-WV40	18
77940	MHS-CARK-V42/1050	96	78142	STS-G	35	78373	SACPL-36/900-S/S	78	78477	CRB-WV46	18
77941	MHS-CARK-V48/1200	89	78142	STS-G	35	78373	SACPL-36/900-S/S	85	78478	CRB-WV52	18
77941	MHS-CARK-V48/1200	96	78142	STS-G	64	78373	SACPL-36/900-S/S	92	78479	CRB-WV58	18
77942	MHS-CARK-V54/1350	89	78142	STS-G	66	78373	SACPL-36/900-S/S	98	78480	CRB-WV64	18
77942	MHS-CARK-V54/1350	96	78142	STS-G	70	78374	SACPL-42/1050-S/S	78	78481	CRB-WV70	18
77943	MHS-CARK-V60/1500	89	78142	STS-G	91	78374	SACPL-42/1050-S/S	85	78488	EZPIT-212	19
77943	MHS-CARK-V60/1500	96	78142	STS-G	109	78374	SACPL-42/1050-S/S	92	78489	EZPIT-218	19
77944	MHS-CARK-V72/1800	89	78142	STS-G	114	78374	SACPL-42/1050-S/S	98	78490	EZPIT-224	19
77944	MHS-CARK-V72/1800	96	78162	MHS-600V-SAC	88	78375	SACPL-48/1200-S/S	78	78491	EZPIT-230	19
77950	MHS-CARK2-V60/1500	89	78163	MHS-750V-SAC	88	78375	SACPL-48/1200-S/S	85	78492	EZPIT-236	19
77950	MHS-CARK2-V60/1500	96	78164	MHS-900V-SAC	88	78375	SACPL-48/1200-S/S	92	78493	EZPIT-242	19
77951	MHS-CARK2-V72/1800	89	78165	MHS-1050V-SAC	88	78375	SACPL-48/1200-S/S	98	78494	EZPIT-248	19
77951	MHS-CARK2-V72/1800	96	78166	MHS-1200V-SAC	88	78376	SACPL-54/1350-S/S	78	78495	EZPIT-254	19
77952	MHS-CARK2-V84/2100	89	78167	MHS-1350V-SAC	88	78376	SACPL-54/1350-S/S	85	78496	EZPIT-260	19
77952	MHS-CARK2-V84/2100	96	78168	MHS-1500V-SAC	88	78376	SACPL-54/1350-S/S	92	78497	EZPIT-272	19
77953	MHS-CARK2-V96/2400	89	78169	MHS-1800V-SAC	88	78376	SACPL-54/1350-S/S	98	78507	EZPTMPK	20
77953	MHS-CARK2-V96/2400	96	78170	MHS-1500V-2SAC	88	78377	SACPL-60/1500-S/S	78	78509	EZPTCKHD	20
77954	MHS-CARK2-V120/3000	89	78171	MHS-1800V-2SAC	88	78377	SACPL-60/1500-S/S	85	78510	EZPTSR	20
77954	MHS-CARK2-V120/3000	96	78172	MHS-2100V-2SAC	88	78377	SACPL-60/1500-S/S	92	78511	EZPTSK	20
78007	MHS-600BTV-SAC	95	78173	MHS-2400V-2SAC	88	78377	SACPL-60/1500-S/S	98	78512	EZPTSKHD	20
78008	MHS-750BTV-SAC	95	78174	MHS-3000V-2SAC	88	78378	SACPL-72/1800-S/S	78	78513	CSTHDM-W	91
78009	MHS-900BTV-SAC	95	78316	MHS-600BTV-SAC-S/S	95	78378	SACPL-72/1800-S/S	85	78514	CSTHDM-S	91
78010	MHS-1050BTV-SAC	95	78317	MHS-750BTV-SAC-S/S	95	78378	SACPL-72/1800-S/S	92	78515	CSTHDM-B	91
78011	MHS-1200BTV-SAC	95	78318	MHS-900BTV-SAC-S/S	95	78378	SACPL-72/1800-S/S	98	78516	CSTHDM-G	91
78012	MHS-1350BTV-SAC	95	78319	MHS-1050BTV-SAC-S/S	95	78379	SACPL2-60/1500-S/S	78	78517	SSTHDM-W	70
78013	MHS-1500BTV-SAC	95	78320	MHS-1200BTV-SAC-S/S	95	78379	SACPL2-60/1500-S/S	85	78517	SSTHDM-W	91
78014	MHS-1800BTV-SAC	95	78321	MHS-1350BTV-SAC-S/S	95	78379	SACPL2-60/1500-S/S	92	78517	SSTHDM-W	109
78015	MHS-1500BTV-2SAC	95	78322	MHS-1500BTV-SAC-S/S	95	78379	SACPL2-60/1500-S/S	98			
78016	MHS-1800BTV-2SAC	95	78323	MHS-1800BTV-SAC-S/S	95	78380	SACPL2-72/1800-S/S	78			
78017	MHS-2100BTV-2SAC	95	78324	MHS-1500BTV-2SAC-S/S	95	78380	SACPL2-72/1800-S/S	85			
78018	MHS-2400BTV-2SAC	95	78325	MHS-1800BTV-2SAC-S/S	95	78380	SACPL2-72/1800-S/S	92			



# INDEX By Item Code

Item Code	Ordering Number	Page #	Item Code	Ordering Number	Page #	Item Code	Ordering Number	Page #	Item Code	Ordering Number	Page #
78518	SST1HDM-S	70	78582	CART-60/1500-S/S	97	78789	SB4	148	79200	SPFC	90
78518	SST1HDM-S	91	78582	CART-60/1500-S/S	98	78789	SB4	149	79200	SPFC	97
78518	SST1HDM-S	109	78583	CART-72/1800-S/S	41	78790	SB5	137	79201	SPFC-S/S	66
78518	SST1HDM-S	110	78583	CART-72/1800-S/S	46	78790	SB5	139	79201	SPFC-S/S	68
78519	SST1HDM-B	70	78583	CART-72/1800-S/S	76	78790	SB5	141	79201	SPFC-S/S	70
78519	SST1HDM-B	91	78583	CART-72/1800-S/S	78	78790	SB5	144	79201	SPFC-S/S	93
78519	SST1HDM-B	109	78583	CART-72/1800-S/S	83	78790	SB5	148	79201	SPFC-S/S	99
78537	MHS-600V-SAC-S/S	88	78583	CART-72/1800-S/S	85	78790	SB5	149	79206	USPB	104
78538	MHS-750V-SAC-S/S	88	78583	CART-72/1800-S/S	90	78790	SB5	150	79206	USPB	105
78539	MHS-900V-SAC-S/S	88	78583	CART-72/1800-S/S	92	78791	PATLK	36	79206	USPB2	104
78540	MHS-1050V-SAC-S/S	88	78583	CART-72/1800-S/S	97	78794	PATHK	36	79206	USPB2	105
78541	MHS-1200V-SAC-S/S	88	78583	CART-72/1800-S/S	98	78808	EST-P-S/S	17	79207	UHPB	104
78542	MHS-1350V-SAC-S/S	88	78584	CART2-60/1500-S/S	42	78809	EST-W-S/S	17	79207	UHPB	105
78543	MHS-1500V-SAC-S/S	88	78584	CART2-60/1500-S/S	47	78810	EST-G-S/S	17	79224	CCKL	59
78544	MHS-1800V-SAC-S/S	88	78584	CART2-60/1500-S/S	76	78812	EZP1P12-S/S	17	79224	CCKL	61
78545	MHS-1500V-2SAC-S/S	88	78584	CART2-60/1500-S/S	78	78838	CFG-212	14	79225	CCKHDL	59
78546	MHS-1800V-2SAC-S/S	88	78584	CART2-60/1500-S/S	83	78839	CFG-218	14	79225	CCKHDL	61
78547	MHS-2100V-2SAC-S/S	88	78584	CART2-60/1500-S/S	85	78840	CFG-224	14	79225	CCKHDL	68
78548	MHS-2400V-2SAC-S/S	88	78584	CART2-60/1500-S/S	90	78841	CFG-230	14	79225	CCKHDL	114
78549	MHS-3000V-2SAC-S/S	88	78584	CART2-60/1500-S/S	92	78842	CFG-236	14	79226	CCKL-S/S	59
78576	CART-24/600-S/S	41	78584	CART2-60/1500-S/S	97	78843	CFG-242	14	79226	CCKL-S/S	61
78576	CART-24/600-S/S	46	78584	CART2-60/1500-S/S	99	78844	CFG-248	14	79227	CCKHDL-S/S	59
78576	CART-24/600-S/S	76	78585	CART2-72/1800-S/S	42	78845	CFG-254	14	79227	CCKHDL-S/S	61
78576	CART-24/600-S/S	78	78585	CART2-72/1800-S/S	47	78846	CFG-260	14	79227	CCKHDL-S/S	68
78576	CART-24/600-S/S	83	78585	CART2-72/1800-S/S	76	78847	CFG-272	14	79227	CCKHDL-S/S	114
78576	CART-24/600-S/S	85	78585	CART2-72/1800-S/S	78	78848	EZP1P1-S/S	17	79228	CCKR	59
78576	CART-24/600-S/S	90	78585	CART2-72/1800-S/S	83	78849	ESTAK-EST-S/S	17	79228	CCKR	61
78576	CART-24/600-S/S	92	78585	CART2-72/1800-S/S	85	78849	ESTAK-EST-S/S	35	79229	CCKHDR	59
78576	CART-24/600-S/S	97	78585	CART2-72/1800-S/S	90	78849	ESTAK-S/S	105	79229	CCKHDR	61
78576	CART-24/600-S/S	98	78585	CART2-72/1800-S/S	92	78850	LS-SW-S/S	12	79229	CCKHDR	68
78577	CART-30/750-S/S	76	78585	CART2-72/1800-S/S	97	78919	CCMK	51	79229	CCKHDR	114
78577	CART-30/750-S/S	78	78585	CART2-72/1800-S/S	99	78919	CCMK	59	79230	CCKR-S/S	59
78577	CART-30/750-S/S	83	78586	CART2-84/2100-S/S	42	78919	CCMK	61	79230	CCKR-S/S	61
78577	CART-30/750-S/S	85	78586	CART2-84/2100-S/S	47	78920	CCMKHD	55	79231	CCKHDR-S/S	59
78577	CART-30/750-S/S	90	78586	CART2-84/2100-S/S	76	78920	CCMKHD	59	79231	CCKHDR-S/S	61
78577	CART-30/750-S/S	92	78586	CART2-84/2100-S/S	78	78920	CCMKHD	61	79231	CCKHDR-S/S	68
78577	CART-30/750-S/S	97	78586	CART2-84/2100-S/S	83	78920	CCMKHD	68	79231	CCKHDR-S/S	114
78577	CART-30/750-S/S	98	78586	CART2-84/2100-S/S	85	78920	CCMKHD	114	79232	CCKHDS-S/S	114
78578	CART-36/900-S/S	41	78586	CART2-84/2100-S/S	90	78921	CCMK-S/S	59	79232	CCKTS	59
78578	CART-36/900-S/S	46	78586	CART2-84/2100-S/S	92	78921	CCMK-S/S	61	79232	CCKTS	61
78578	CART-36/900-S/S	76	78586	CART2-84/2100-S/S	97	78922	CCMKHD-S/S	59	79233	CCKHOTS	59
78578	CART-36/900-S/S	78	78586	CART2-84/2100-S/S	99	78922	CCMKHD-S/S	61	79233	CCKHOTS	68
78578	CART-36/900-S/S	83	78586	SSTHK-S/S	70	78922	CCMKHD-S/S	68	79233	CCKHOTS	68
78578	CART-36/900-S/S	85	78587	CART2-96/2400-S/S	42	78922	CCMKHD-S/S	114	79233	CCKHOTS	114
78578	CART-36/900-S/S	90	78587	CART2-96/2400-S/S	47	78923	EZP1MPK-S/S	17	79234	CCKTS-S/S	59
78578	CART-36/900-S/S	92	78587	CART2-96/2400-S/S	76	78933	LSTMPK-S/S	12	79234	CCKTS-S/S	61
78578	CART-36/900-S/S	97	78587	CART2-96/2400-S/S	78	79009	HDRBK	121	79236	HDRGK	121
78578	CART-36/900-S/S	98	78587	CART2-96/2400-S/S	83	79010	HDR24	121	79288	ESS-S-S/S	105
78579	CART-42/1050-S/S	41	78587	CART2-96/2400-S/S	85	79011	HDR30	121	79289	PFC-P-S/S	59
78579	CART-42/1050-S/S	46	78587	CART2-96/2400-S/S	90	79012	HDR36	121	79378	MSR2	170
78579	CART-42/1050-S/S	76	78587	CART2-96/2400-S/S	92	79013	HDR42	121	79378	MSR2-S/S	179
78579	CART-42/1050-S/S	78	78587	CART2-96/2400-S/S	97	79014	HDR48	121	79380	PMSMK2	162
78579	CART-42/1050-S/S	83	78587	CART2-96/2400-S/S	99	79015	HDR54	121	79431	MSTHD-W	64
78579	CART-42/1050-S/S	85	78588	CART2-120/3000-S/S	76	79016	HDR60	121	79431	MSTHD-W	66
78579	CART-42/1050-S/S	90	78588	CART2-120/3000-S/S	78	79017	HDRS72*	121	79431	MSTHD-W	71
78579	CART-42/1050-S/S	92	78588	CART2-120/3000-S/S	83	79018	HDRS84*	121	79432	MSTHD-S	64
78579	CART-42/1050-S/S	97	78588	CART2-120/3000-S/S	85	79019	HDRR24	121	79432	MSTHD-S	66
78579	CART-42/1050-S/S	98	78588	CART2-120/3000-S/S	90	79020	HDRR30	121	79432	MSTHD-S	71
78580	CART-48/1200-S/S	76	78588	CART2-120/3000-S/S	92	79021	HDRR36	121	79433	MSTHD-B	64
78580	CART-48/1200-S/S	78	78588	CART2-120/3000-S/S	97	79022	HDRR42	121	79433	MSTHD-B	66
78580	CART-48/1200-S/S	83	78588	CART2-120/3000-S/S	99	79023	HDRR48	121	79433	MSTHD-B	71
78580	CART-48/1200-S/S	85	78634	CART2-66/1650-S/S	42	79024	HDRR54	121	79434	MSTDB	71
78580	CART-48/1200-S/S	90	78634	CART2-66/1650-S/S	47	79025	HDRR60	121	79435	MSTAM	64
78580	CART-48/1200-S/S	92	78635	CART2-78/1950-S/S	42	79026	HDRR72*	121	79435	MSTAM	66
78580	CART-48/1200-S/S	97	78635	CART2-78/1950-S/S	47	79027	HDRR84*	121	79436	MST-MBL	71
78580	CART-48/1200-S/S	98	78635	CART2-78/1950-S/S	76	79056	PSTS-S-S/S	35	79437	MST-MBR	71
78580	CART2-48/1200-S/S	41	78635	CART2-78/1950-S/S	78	79057	STS-G-S/S	35	79454	SST1HDM-G-S/S	70
78580	CART2-48/1200-S/S	46	78635	CART2-78/1950-S/S	83	79057	STS-G-S/S	35	79494	MBC-18	115
78581	CART-54/1350-S/S	76	78635	CART2-78/1950-S/S	85	79057	STS-G-S/S	64	79495	MBC-24	115
78581	CART-54/1350-S/S	78	78635	CART2-78/1950-S/S	90	79057	STS-G-S/S	66	79496	MBC-30	115
78581	CART-54/1350-S/S	83	78635	CART2-78/1950-S/S	92	79057	STS-G-S/S	70	79497	MBC-36	115
78581	CART-54/1350-S/S	85	78635	CART2-78/1950-S/S	97	79057	STS-G-S/S	109	79498	MBC-42	115
78581	CART-54/1350-S/S	90	78635	CART2-78/1950-S/S	99	79057	STS-G-S/S	114	79499	MBC-48	115
78581	CART-54/1350-S/S	92	78642	SACPL2-78/1950-S/S	78	79060	DWP96	109	79500	MBC-54	115
78581	CART-54/1350-S/S	97	78642	SACPL2-78/1950-S/S	85	79062	CDWB96	110	79501	MBC-60	115
78581	CART-54/1350-S/S	98	78642	SACPL2-78/1950-S/S	92	79063	MDWS-96	108	79502	MBC-72	115
78582	CART-60/1500-S/S	41	78642	SACPL2-78/1950-S/S	98	79069	SST1HDM-G	70	79503	MBC-84	115
78582	CART-60/1500-S/S	46	78649	MHS-1950V-2SAC-S/S	88	79069	SST1HDM-G	91	79504	MBDS-18	116
78582	CART-60/1500-S/S	76	78656	PV1950-2SAC-S/S	74	79069	SST1HDM-G	93	79505	MBDS-24	116
78582	CART-60/1500-S/S	78	78663	RV1950-2SAC-S/S	81	79069	SST1HDM-G	109	79506	MBDS-30	116
78582	CART-60/1500-S/S	83	78789	SB4	137	79072	HDRBK-HD	121	79507	MBDS-36	116
78582	CART-60/1500-S/S	85	78789	SB4	139	79200	SPFC	66	79508	MBDS-42	116
78582	CART-60/1500-S/S	90	78789	SB4	141	79200	SPFC	68	79509	MBDS-48	116
78582	CART-60/1500-S/S	92	78789	SB4	144	79200	SPFC	70	79510	MBDS-54	116

# INDEX By Item Code

Item Code	Ordering Number	Page #	Item Code	Ordering Number	Page #	Item Code	Ordering Number	Page #	Item Code	Ordering Number	Page #
79511	MBDS-60	116	79829	YCART-36/900-HDTC	53	81896	MESPKR	104	82351	EZWPK-1500	139
79512	MBDS-72	116	79830	YCART-42/1050-HDTC	53	82174	QMTBK-GCN	104	82351	EZWPK-1500	141
79513	MBDS-84	116	79831	YCART-48/1200-HDTC	53	82174	QMTBK-GCN	105	82351	EZWPK-1500	144
79514	MBRD-18	115	79832	YCART-54/1350-HDTC	53	82175	QMTBK-WV-MT	104	82352	EZWPK-1800	137
79514	MBRD-18	116	79833	YCART-60/1500-HDTC	53	82175	QMTBK-WV-MT	105	82352	EZWPK-1800	139
79515	MBRD-24	115	79834	YCART-72/1800-HDTC	53	82182	QMTBPK-CN	104	82352	EZWPK-1800	141
79515	MBRD-24	116	79835	YTACHD	55	82185	EZSB600-1200C	136	82352	EZWPK-1800	144
79516	MBRD-30	115	79836	YST-Y	51	82186	EZSB750-1200C	136	82353	EZCSK-600	137
79516	MBRD-30	116	79837	YST-P	51	82187	EZSB900-1200C	136	82353	EZCSK-600	139
79517	MBRD-36	115	79838	YST-S	51	82188	EZSB1050-1200C	136	82354	EZCSK-750	137
79517	MBRD-36	116	79839	YSTDH-GR	55	82189	EZSB1200-1200C	136	82354	EZCSK-750	139
79518	MBRD-42	115	79840	YSTDH-S	55	82190	EZSB1350-1200C	136	82355	EZCSK-900	137
79518	MBRD-42	116	79841	YSTDH-BL	55	82191	EZSB1500-1200C	136	82355	EZCSK-900	139
79519	MBRD-48	115	79842	YSTDH-BK	55	82192	EZSB1800-1200C	136	82356	EZCSK-1050	137
79519	MBRD-48	116	79843	YSTMB	51	82193	EZSB600-1500C	136	82356	EZCSK-1050	139
79520	MBRD-54	115	79845	YSTGBK	51	82194	EZSB750-1500C	136	82357	EZCSK-1200	137
79520	MBRD-54	116	79846	YSTLKB	51	82195	EZSB900-1500C	136	82357	EZCSK-1200	139
79521	MBRD-60	115	79847	YSTTBK-W	51	82196	EZSB1050-1500C	136	82358	EZCSK-1350	137
79521	MBRD-60	116	79848	YSTPMK	51	82197	EZSB1200-1500C	136	82358	EZCSK-1350	139
79522	MBRD-72	115	79849	YSTDHMB	55	82198	EZSB1350-1500C	136	82359	EZCSK-1500	137
79522	MBRD-72	116	79850	YSTDHDBK	55	82199	EZSB1500-1500C	136	82359	EZCSK-1500	139
79523	MBRD-84	115	79851	YSTDHGBK	55	82200	EZSB1800-1500C	136	82360	EZCSK-1800	137
79523	MBRD-84	116	79852	YSTDHLBK	55	82201	EZSB600-1200I	138	82360	EZCSK-1800	139
79524	MBCMK	116	79853	YSTDHDBK-W	55	82202	EZSB750-1200I	138	82361	EZBS-1200	141
79525	MBCBC	116	79854	YSTPHDMK	55	82203	EZSB900-1200I	138	82362	EZBS-1500	141
79526	MBCB	116	79855	YSTTBK-B	51	82204	EZSB1050-1200I	138	82364	MESBK-PS	104
79527	MBADB	116	79856	YSTDHDBK-B	55	82205	EZSB1200-1200I	138	82364	MESBK-PS	105
79528	MBCBM	116	79857	YSTANK	51	82206	EZSB1350-1200I	138	82393	SHIM-LDKIT	137
79529	MBCM-1	116	79858	YSTANKHD	55	82207	EZSB1500-1200I	138	82393	SHIM-LDKIT	139
79530	MBCM-2	116	79936	CBS18SF	112	82208	EZSB1800-1200I	138	82393	SHIM-LDKIT	141
79531	MBCTA	116	79937	CBS24SF	112	82209	EZSB600-1500I	138	82394	SHIM-MDKIT	144
79532	MBCBL	116	79938	CBS30SF	112	82210	EZSB750-1500I	138	82397	IBS-M1200	144
79533	MBCMCK	116	79939	CBS36SF	112	82211	EZSB900-1500I	138	82398	IBS-M1500	144
79534	MBCEC	116	79940	CBS42SF	112	82212	EZSB1050-1500I	138	82699	USP18/450	104
79535	STLP	116	79941	CBS48SF	112	82213	EZSB1200-1500I	138	82690	USP24/600	104
79536	MBCDBK	115	79942	CBS54SF	112	82214	EZSB1350-1500I	138	82691	USP30/750	104
79536	MBCDBK	116	79947	CBSBLD18F	112	82215	EZSB1500-1500I	138	82692	USP36/900	104
79573	YT-P*	49	79948	CBSBLD24F	112	82216	EZSB1800-1500I	138	82693	USP42/1050	104
79574	YT-C*	49	79949	CBSBLD30F	112	82281	EZBKM-600	141	82694	USP48/1200	104
79582	SSTHK	70	79950	CBSBLD36F	112	82281	EZBKM-600	144	82695	USP54/1350	104
79582	SSTHK	109	79951	CBSBLD42F	112	82282	EZBKM-750	141	82696	USP66/1400	104
79582	SSTHK	114	79952	CBSBLD48F	112	82282	EZBKM-750	144	82697	USP60/1500	104
79586	SSTHK-S/S	109	79953	CBSBLD54F	112	82283	EZBKM-900	141	82698	USP64/1600	104
79586	SSTHK-S/S	114	79954	CBSBLD60F	112	82283	EZBKM-900	144	82699	USP72/1800	104
79617	YCART-18/450-P	49	79955	CBSBLD72F	112	82284	EZBKM-1050	141	82700	USP80/2000	104
79618	YCART-24/600-P	49	79956	CBSBLD84F	112	82284	EZBKM-1050	144	82701	USP84/2100	104
79619	YCART-30/750-P	49	79957	CBSBLD96F	112	82285	EZBKM-1200	141	82702	USP88/2200	104
79620	YCART-36/900-P	49	81045	C-PSTA	104	82285	EZBKM-1200	144	82703	USP94/2400	104
79621	YCART-42/1050-P	49	81250	RIBBK	137	82286	EZBKM-1350	141	82704	USP98/2500	104
79622	YCART-48/1200-P	49	81250	RIBBK	139	82286	EZBKM-1350	144	82707	UTV450-S/S	102
79623	YTAC	51	81250	RIBBK	141	82287	EZBKM-1500	141	82708	UTV600-S/S	102
79647	FMS-600V	62	81250	RIBBK	144	82287	EZBKM-1500	144	82709	UTV750-S/S	102
79648	FMS-750V	62	81315	DRXH-24-420	149	82288	EZBKM-1800	141	82710	UTV900-S/S	102
79649	FMS-900V	62	81316	DRXH-24-520	149	82288	EZBKM-1800	144	82711	UTV1050-S/S	102
79650	FMS-1050V	62	81317	DRXH-24-435	149	82289	MPSTA-S/S	105	82712	UTV1200-S/S	102
79651	FMS-1200V	62	81318	DRXH-24-535	149	82342	PTPK-MT-S/S	105	82713	UTV1350-S/S	102
79652	FMS-1350V	62	81319	DRXH-30-420	149	82343	PTPK-MT	104	82714	UTV1400-S/S	102
79653	FMS-1500V	62	81320	DRXH-30-520	149	82344	EZRMMK	137	82715	UTV1500-S/S	102
79654	FMS-1800V	62	81321	DRXH-30-620	149	82344	EZRMMK	139	82716	UTV1600-S/S	102
79655	HSA8SSS-S/S	34	81322	DRXH-30-535	149	82345	EZWPK-600	137	82717	UTV1800-S/S	102
79677	YT-HDP*	53	81323	DRXH-36-420	149	82345	EZWPK-600	139	82718	UTV2000-S/S	102
79728	YT-HDC*	53	81324	DRXH-36-520	149	82345	EZWPK-600	141	82719	UTV2100-S/S	102
79795	YSTS-Y	51	81325	DRXH-36-435	149	82345	EZWPK-600	144	82720	UTV2200-S/S	102
79796	YSTS-P	51	81326	DRXH-36-535	149	82346	EZWPK-750	137	82721	UTV2400-S/S	102
79797	YSTDHS-GR	55	81327	DRXH-42-420	149	82346	EZWPK-750	139	82722	UTV2500-S/S	102
79798	YSTDHS-BL	55	81328	DRXH-42-520	149	82346	EZWPK-750	141	82810	SCU60-S/S	105
79805	YTAHD-36/900	55	81329	DRXH-42-435	149	82346	EZWPK-750	144	82811	SCUHD-S/S	105
79806	YTAHD-42/1050	55	81330	DRXH-42-535	149	82347	EZWPK-900	137	82812	SCU60	104
79807	YTAHD-48/1200	55	81331	DRXH-48-420	149	82347	EZWPK-900	139	82813	SCUHD	105
79808	YTAHD-54/1350	55	81332	DRXH-48-520	149	82347	EZWPK-900	141	82815	P-CARK-V24/600-S/S PVECKS/S	75
79809	YTAHD-60/1500	55	81333	DRXH-48-435	149	82347	EZWPK-900	144	82816	P-CARK-V30/750-S/S PVECKS/S	75
79810	YTAHD-72/1800	55	81334	DRXH-48-535	149	82348	EZWPK-1050	137	82817	P-CARK-V36/900-S/S PVECKS/S	75
79811	YCART-18/450-TC	49	81335	DRXH-54-420	149	82348	EZWPK-1050	139	82818	P-CARK-V42/1050-S/S PVECKS/S	75
79812	YCART-24/600-TC	49	81336	DRXH-54-520	149	82348	EZWPK-1050	141	82819	P-CARK-V48/1200-S/S PVECKS/S	75
79813	YCART-30/750-TC	49	81337	DRXH-54-435	149	82348	EZWPK-1050	144	82820	P-CARK-V54/1350-S/S PVECKS/S	75
79814	YCART-36/900-TC	49	81338	DRXH-54-535	149	82349	EZWPK-1200	137	82821	P-CARK-V60/1500-S/S PVECKS/S	75
79815	YCART-42/1050-TC	49	81339	DRXH-60-420	149	82349	EZWPK-1200	139	82822	P-CARK-V72/1800-S/S PVECKS/S	75
79816	YCART-48/1200-TC	49	81340	DRXH-60-520	149	82349	EZWPK-1200	141	82823	P-CARK2-V60/1500-S/S PV2ECKSS	75
79817	YCART-36/900-HDP	53	81341	DRXH-60-435	149	82349	EZWPK-1200	144	82824	P-CARK2-V72/1800-S/S PV2ECKSS	75
79818	YCART-42/1050-HDP	53	81342	DRXH-60-535	149	82350	EZWPK-1350	137	82825	P-CARK2-V84/2100-S/S PV2ECKSS	75
79819	YCART-48/1200-HDP	53	81343	DRXH-72-420	149	82350	EZWPK-1350	139	82826	P-CARK2-V96/2400-S/S PV2ECKSS	75
79820	YCART-54/1350-HDP	53	81344	DRXH-72-520	149	82350	EZWPK-1350	141	82827	P-CARK2-V120/3000-S/S PV2ECKSS	75
79821	YCART-60/1500-HDP	53	81345	DRXH-72-435	149	82350	EZWPK-1350	144	82828	R-CARK-V24/600-S/S RVECKS/S	82
79822	YCART-72/1800-HDP	53	81346	DRXH-72-535	149	82351	EZWPK-1500	137	82829	R-CARK-V30/750-S/S RVECKS/S	82



# INDEX By Item Code

Item Code	Ordering Number	Page #	Item Code	Ordering Number	Page #	Item Code	Ordering Number	Page #	Item Code	Ordering Number	Page #
82830	R-CARK-V36/900-S/S RVECK/S	82	83124	YTHD-1500S	52	83746	SE6-R2000	172	90266	PTEZ-600	164
82831	R-CARK-V42/1050-S/S RVECK/S	82	83126	YTHD-1800S	52	83747	SE6-R2200	172	90267	PTEZ-750	164
82832	R-CARK-V48/1200-S/S RVECK/S	82	83134	YTHD-TC-900S	52	83748	SE6-VR1800	172	90268	PTEZ-900	164
82833	R-CARK-V54/1350-S/S RVECK/S	82	83135	YTHD-TC-1050S	52	83749	SE6-VR2000	172	90269	PTEZ-1050	164
82834	R-CARK-V60/1500-S/S RVECK/S	82	83136	YTHD-TC-1200S	52	83750	SE6-VR2200	172	90270	PTEZ-1200	164
82835	R-CARK-V72/1800-S/S RVECK/S	82	83137	YTHD-TC-1350S	52	83785	PTMA-750-3	171	90283	SKPU-150x12x7.6	175
82836	R-CARK2-V60/1500-S/S RV2ECKSS	82	83138	YTHD-TC-1500S	52	83786	PTMA-750-1	171	90284	SKPU-150x20x7.6	175
82837	R-CARK2-V72/1800-S/S RV2ECKSS	82	83140	YTHD-TC-1800S	52	83788	4.5" STEEL ROLLER - PTM 650	172	90285	SKPU-200x12x7.6	175
82838	R-CARK2-V84/2100-S/S RV2ECKSS	82	83223	YTC-450	48	84086	CBSHD-1500P	114	90286	SKPU-200x20x7.6	175
82839	R-CARK2-V96/2400-S/S RV2ECKSS	82	83224	YTC-600	48	84087	CBSHD-1800P	114	90537	CBCS18	117
82840	R-CARK2-V120/3000-S/S RV2ECKSS	82	83225	YTC-750	48	84088	CBSHD-2100P	114	90538	CBCS24	117
82841	MHS-CARK-V24/600-S/S MVECK/S	89	83226	YTC-900	48	84089	CBSHD-2400P	114	90539	CBCS30	117
82841	MHS-CARK-V24/600-S/S MVECK/S	96	83227	YTC-1050	48	84116	CBSHD-1500P	114	90540	CBCS36	117
82842	MHS-CARK-V30/750-S/S MVECK/S	89	83228	YTC-1200	48	84117	CBSHD-1800P	114	90541	CBCS42	117
82842	MHS-CARK-V30/750-S/S MVECK/S	96	83229	YT-450S	48	84118	CBSHD-2100P	114	90542	CBCS48	117
82843	MHS-CARK-V36/900-S/S MVECK/S	89	83230	YT-600S	48	84119	CBSHD-2400P	114	90543	CBCS54	117
82843	MHS-CARK-V36/900-S/S MVECK/S	96	83231	YT-750S	48	84130	CBS60SF	112	90544	CBCS60	117
82844	MHS-CARK-V42/1050-S/S MVECK/S	89	83232	YT-900S	48	84131	CBS72SF	112	90616	PTEZHD-1050	164
82844	MHS-CARK-V42/1050-S/S MVECK/S	96	83233	YT-1050S	48	84132	CBS84SF	112	90617	PTEZHD-1200	164
82845	MHS-CARK-V48/1200-S/S MVECK/S	89	83234	YT-1200S	48	84133	CBS96SF	112	90618	PTEZHD-1350	164
82845	MHS-CARK-V48/1200-S/S MVECK/S	96	83241	YT-TC-450S	48	87895	MESPBL	104	90619	PTEZHD-1500	164
82846	MHS-CARK-V54/1350-S/S MVECK/S	89	83242	YT-TC-600S	48	88363	DRXM-24-420	148	90620	PTEZHD-1800	164
82846	MHS-CARK-V54/1350-S/S MVECK/S	96	83243	YT-TC-750S	48	88364	DRXM-24-520	148	90621	PTEZHD-2100	164
82847	MHS-CARK-V60/1500-S/S MVECK/S	89	83244	YT-TC-900S	48	88365	DRXM-24-435	148	90631	CRDF18	117
82847	MHS-CARK-V60/1500-S/S MVECK/S	96	83245	YT-TC-1050S	48	88366	DRXM-24-535	148	90632	CRDF24	117
82848	MHS-CARK-V72/1800-S/S MVECK/S	89	83246	YT-TC-1200S	48	88367	DRXM-30-420	148	90633	CRDF30	117
82848	MHS-CARK-V72/1800-S/S MVECK/S	96	83661	PTMA-900-3	171	88368	DRXM-30-520	148	90634	CRDF36	117
82849	MHS-CARK2-V60/1500-S/S MV2CKSS	89	83662	PTMA-1050-3	171	88369	DRXM-30-435	148	90635	CRDF42	117
82849	MHS-CARK2-V60/1500-S/S MV2CKSS	96	83663	PTMA-1200-3	171	88370	DRXM-30-535	148	90636	CRDF48	117
82850	MHS-CARK2-V72/1800-S/S MV2CKSS	89	83664	PTMA-1350-3	171	88371	DRXM-36-420	148	90637	CRDF54	117
82850	MHS-CARK2-V72/1800-S/S MV2CKSS	96	83665	PTMA-1600-3	171	88372	DRXM-36-520	148	90638	CRDF60	117
82851	MHS-CARK2-V84/2100-S/S MV2CKSS	89	83666	PTMA-1800-3	171	88373	DRXM-36-435	148	90641	CBC3R	117
82851	MHS-CARK2-V84/2100-S/S MV2CKSS	96	83667	PTMA-900-1	171	88374	DRXM-36-535	148	90795	PTEZHD-1400	164
82852	MHS-CARK2-V96/2400-S/S MV2CKSS	89	83668	PTMA-1050-1	171	88375	DRXM-42-420	148	90796	PTEZHD-1600	164
82852	MHS-CARK2-V96/2400-S/S MV2CKSS	96	83669	PTMA-1200-1	171	88376	DRXM-42-520	148	90797	PTEZHD-2000	164
82853	MHS-CARK2-V120/3000-S/S MV2CKSS	89	83670	PTMA-1350-1	171	88377	DRXM-42-435	148	90803	PTEZHD-MBK	164
82853	MHS-CARK2-V120/3000-S/S MV2CKSS	96	83671	PTMA-1600-1	171	88378	DRXM-42-535	148	90804	PTEZHD-PBK	164
82876	P-CARK2-V78/1950-S/S PV2ECKSS	75	83672	PTMA-1800-1	171	88379	DRXM-48-420	148	90805	PTEZHD-DCK	164
82887	UHSPK-M	104	83673	PTMA-750-2	171	88380	DRXM-48-520	148	90806	PTEZHD-WRBK	164
82888	USPK-SS-M	105	83674	PTMA-1050-2	171	88381	DRXM-48-435	148	90807	PTEZHD-JBBK	164
82889	UHSPK-SS-M	105	83675	PTMA-1200-2	171	88382	DRXM-48-535	148	91090		57
82890	UMBK-M	104	83676	PTMA-1350-2	171	88383	DRXM-54-420	148	91091		57
82891	UMBK-SS-M	105	83677	PTMA-1600-2	171	88384	DRXM-54-520	148	91092		57
82892	MESPBL-SS	105	83678	PTMA-1800-2	171	88385	DRXM-54-435	148	91222	SKPU-150x12x15.2	175
82893	MUPSBK-SS	105	83679	SE5-T800	172	88386	DRXM-54-535	148	91223	SKPU-150x19x15.2	175
82894	MESPKR-SS	105	83680	SE5-T1000	172	88387	DRXM-60-420	148	91224	SKPU-200x12x15.2	175
82895	MQMTS BK-SS	105	83681	SE5-T1200	172	88388	DRXM-60-520	148	91225	SKPU-200x19x15.2	175
82896	MUPSBK	104	83682	SE5-T1400/VR1000	172	88389	DRXM-60-435	148	91234	SKPU-300x25x7.6	175
82897	UST-P-MT	104	83682	SE5-T1400/VR1000	172	88390	DRXM-60-535	148	91254	CRB-UHT-400	18
82898	UST-S-MT	104	83683	SE5-T1600	172	88391	DRXM-72-420	148	91255	CRB-UHT-550	18
82899	UST-W-MT	104	83684	SE5-T1800	172	88392	DRXM-72-520	148	91256	CRB-UHT-700	18
82900	UST-G-MT	104	83685	SE6-R800	172	88393	DRXM-72-435	148	91257	CRB-UHT-850	18
82901	UST-P-MT-SS	105	83686	SE6-R1000	172	88394	DRXM-72-535	148	91258	CRB-UHT-1000	18
82902	UST-S-MT-SS	105	83687	SE6-R1200	172	90151	MHP-6108	26	91259	CRB-UHT-1150	18
82903	UST-W-MT-SS	105	83688	SE6-R1400	172	90152	MHP-6120	26	91260	CRB-UHT-1300	18
82904	UST-G-MT-SS	105	83689	SE6-R1600	172	90181	MSTHD-SS-W	66	91261	CRB-UHT-1450	18
82932	YTP-18/450	51	83690	SE6-R1800	172	90181	MSTHD-SS-W	71	91263	CRB-UHT-1750	18
82933	YTP-24/600	51	83690	SE6-R1800	172	90181	MSTHD-W-S/S	64	91288	SKPU-100x10x7.6	175
82934	YTP-30/750	51	83691	SE5-VR800	172	90182	MSTHD-S-S/S	57	91289	SKPU-100x12x7.6	175
82935	YTP-36/900	51	83692	SE5-VR1200	172	90182	MSTHD-S-S/S	64	91290	SKPU-100x16x7.6	175
82936	YTP-42/1050	51	83693	SE5-VR1400	172	90182	MSTHD-SS-S	66	91291	SKPU-100x19x7.6	175
82937	YTP-48/1200	51	83694	SE5-VR1600	172	90182	MSTHD-SS-S	71	91292	SKPU-100x25x7.6	175
82949	YTA-18/450	51	83695	SE5-VR1800	172	90183	MSTHD-B-S/S	57	91293	SKPU-100x10x15.2	175
82950	YTA-24/600	51	83715	N6D3T-24-9-A45	137	90183	MSTHD-B-S/S	64	91294	SKPU-100x12x15.2	175
82951	YTA-30/750	51	83716	N6D3T-30-11-A45	137	90183	MSTHD-SS-B	66	91295	SKPU-100x16x15.2	175
82952	YTA-36/900	51	83717	N6D3T-36-13-A45	137	90183	MSTHD-SS-B	71	91296	SKPU-100x19x15.2	175
82953	YTA-42/1050	51	83718	N6D3T-42-15-A45	137	90184	MSTHD-G-S/S	57	91297	SKPU-100x25x15.2	175
82954	YTA-48/1200	51	83719	N6D3T-48-17-A45	137	90184	MSTHD-G-S/S	64	91298	SKPU-150x10x7.6	175
83099	YTCHD-900	52	83720	N6D3T-54-19-A45	137	90184	MSTHD-SS-G	66	91299	SKPU-150x16x7.6	175
83100	YTCHD-1050	52	83721	N6D3T-60-21-A45	137	90184	MSTHD-SS-G	71	91300	SKPU-150x25x7.6	175
83101	YTCHD-1200	52	83722	N6D3T-72-25-A45	137	90185	PTMAFMKT	172	91301	SKPU-150x10x15.2	175
83102	YTCHD-1350	52	83734	PTMAHD-1800-3	171	90186	PTMAFMKR	172	91302	SKPU-150x16x15.2	175
83103	YTCHD-1500	52	83735	PTMAHD-2000-3	171	90187	PTMAFMKHDR	172	91303	SKPU-150x25x15.2	175
83105	YTCHD-1800	52	83736	PTMAHD-2400-3	171	90188	PTMAEKT	172	91304	SKPU-200x10x7.6	175
83106	YTPHD-36/900	55	83737	PTMAHD-1800-1	171	90189	PTMAEKR	172	91305	SKPU-200x16x7.6	175
83107	YTPHD-42/1050	55	83738	PTMAHD-2000-1	171	90190	PTMAEKVR	172	91306	SKPU-200x25x7.6	175
83108	YTPHD-48/1200	55	83739	PTMAHD-2400-1	171	90191	PTMAEKHDT	172	91307	SKPU-200x10x15.2	175
83109	YTPHD-54/1350	55	83740	PTMAHD-1800-2	171	90192	PTMAEKHDR	172	91308	SKPU-200x16x15.2	175
83110	YTPHD-60/1500	55	83741	PTMAHD-2000-2	171	90193	PTMAEKHDVR	172	91309	SKPU-200x25x15.2	175
83112	YTPHD-72/1800	55	83742	PTMAHD-2400-2	171	90194	PTMAAK	172	91310	SKPU-250x10x7.6	175
83120	YTHD-900S	52	83743	SE6-T1800	172	90195	PTMAAKHD	172	91311	SKPU-250x12x7.6	175
83121	YTHD-1050S	52	83744	SE6-T2000	172	90197	PTMAORK	172	91312	SKPU-250x16x7.6	175
83122	YTHD-1200S	52	83745	SE6-T2200/R650	172	90264	ESBK-ATEX	17	91313	SKPU-250x19x7.6	175
83123	YTHD-1350S	52	83745	SE6-T2200/R650	172	90265	PTEZ-450	164	91314	SKPU-250x25x7.6	175

# INDEX By Item Code

Item Code	Ordering Number	Page #	Item Code	Ordering Number	Page #	Item Code	Ordering Number	Page #	Item Code	Ordering Number	Page #
91315	SKPU-250x10x15.2	175	91797	RBVP-HD-S-3200	157	106069	MXDP-84/2100	160	108467	CBS60SC	112
91316	SKPU-250x12x15.2	175	91798	YTR-18S	48	106070	MXDP-96/2400	160	108468	CBS72SC	112
91317	SKPU-250x16x15.2	175	91799	YTR-24S	48	106071	MXDP-108/2700	160	108469	CBS54SC	112
91318	SKPU-250x19x15.2	175	91800	YTR-30S	48	106072	MXDP-120/3000	160	108470	CBS96SC	112
91319	SKPU-250x25x15.2	175	91801	YTR-36S	48	106095	MXDP-MAK	161	108846	EBC-1-NC	134
91320	SKPU-300x10x7.6	175	91802	YTR-42S	48	106106	MXDPH-48/1200	161	108847	EBC-2-NC	134
91321	SKPU-300x12x7.6	175	91803	YTR-48S	48	106107	MXDPH-54/1350	161	108848	CEBC-1-NC	134
91322	SKPU-300x16x7.6	175	91804	YTR-R*	49	106108	MXDPH-60/1500	161	108849	CEBC-2-NC	134
91323	SKPU-300x19x7.6	175	91805	YCART-18/450-R	49	106109	MXDPH-66/1650	161	108850	PBC-1-NC	134
91325	SKPU-300x10x15.2	175	91806	YCART-24/600-R	49	106110	MXDPH-72/1800	161	108851	PBC-2-NC	134
91326	SKPU-300x12x15.2	175	91807	YCART-30/750-R	49	106111	MXDPH-78/1950	161	109370	DVC-SUB-N-AU	125
91327	SKPU-300x16x15.2	175	91808	YCART-36/900-R	49	106112	MXDPH-84/2100	161	109467	EST-P	16
91328	SKPU-300x19x15.2	175	91809	YCART-42/1050-R	49	106113	MXDPH-96/2400	161	109468	EST-S	16
91329	SKPU-300x25x15.2	175	91810	YCART-48/1200-R	49	106114	MXDPH-108/2700	161	109469	EST-B	16
91400	SKPU-DUAL-150x12x7.6	174	91816	YTHDR-36S	52	106115	MXDPH-120/3000	161	109827	SSTXDM-S/S	114
91401	SKPU-DUAL-150x20x7.6	174	91817	YTHDR-42S	52	106122	MXDPB-48/1200	160	111424	SSTXD-W-S/S	114
91402	SKPU-DUAL-200x12x7.6	174	91818	YTHDR-48S	52	106122	MXDPB-48/1200	160	111425	SSTXD-S-S/S	114
91403	SKPU-DUAL-200x20x7.6	174	91819	YTHDR-54S	52	106123	MXDPB-54/1350	160	111426	SSTXD-B-S/S	114
91404	SKPU-DUAL-150x12x15.2	174	91820	YTHDR-60S	52	106123	MXDPB-54/1350	160	111427	SSTXD-G-S/S	114
91405	SKPU-DUAL-150x20x15.2	174	91821	YTHDR-72S	52	106124	MXDPB-60/1500	161	111752	CBS18SF	112
91406	SKPU-DUAL-200x12x15.2	174	91822	YT-HDR*	53	106124	MXDPB-60/1500	161	111753	CBS24SF	112
91407	SKPU-DUAL-200x20x15.2	174	91823	YCART-36/900-HDR	53	106125	MXDPB-66/1650	161	111754	CBS30SF	112
91412	SSTXDMK	70	91824	YCART-42/1050-HDR	53	106125	MXDPB-66/1650	161	111755	CBS36SF	112
91412	SSTXDMK	90	91825	YCART-48/1200-HDR	53	106126	MXDPB-72/1800	160	111756	CBS42SF	112
91412	SSTXDMK	109	91826	YCART-54/1350-HDR	53	106126	MXDPB-72/1800	160	111757	CBS48SF	112
91444	FMSC2	64	91827	YCART-60/1500-HDR	53	106127	MXDPB-78/1950	161	111758	CBS54SF	112
91444	FMSC2	64	91828	YCART-72/1800-HDR	53	106127	MXDPB-78/1950	161	111782	SSTXD-W	114
91495	CBS18SC	112	93089	PTS-ASR	166	106128	MXDPB-84/2100	160	111783	SSTXD-S	114
91496	CBS24SC	112	93090	PTS-AHDSR	166	106128	MXDPB-84/2100	161	111784	SSTXD-B	114
91497	CBS30SC	112	102132	CBS60SF	112	106129	MXDPB-96/2400	160	111785	SSTXD-G	114
91498	CBS36SC	112	102133	CBS72SF	112	106129	MXDPB-96/2400	160	111963	CBSC-450-BT	112
91499	CBS42SC	112	102134	CBS84SF	112	106130	MXDPB-108/2700	161	111964	CBSC-600-BT	112
91500	CBS48SC	112	102135	CBS96SF	112	106130	MXDPB-108/2700	161	111965	CBSC-750-BT	112
91501	CBS54SC	112	103244	CBS-450-BT	112	106131	MXDPB-120/3000	160	111966	CBSC-900-BT	112
91527	CBSBLD18C	112	103245	CBS-600-BT	112	106131	MXDPB-120/3000	161	111967	CBSC-1050-BT	112
91528	CBSBLD24C	112	103246	CBS-750-BT	112	106265	MXDP-48/1200-H	160	111968	CBSC-1200-BT	112
91529	CBSBLD30C	112	103247	CBS-900-BT	112	106266	MXDP-54/1350-H	160	111969	CBSC-1350-BT	112
91530	CBSBLD36C	112	103248	CBS-1050-BT	112	106267	MXDP-60/1500-H	160	111970	CBSCHD-1500-BT	112
91531	CBSBLD42C	112	103249	CBS-1200-BT	112	106268	MXDP-66/1650-H	160	111971	CBSCHD-1800-BT	112
91532	CBSBLD48C	112	103250	CBS-1350-BT	112	106269	MXDP-72/1800-H	160	111972	CBSCHD-2100-BT	112
91533	CBSBLD54C	112	103255	CBSHD-1500-BT	112	106270	MXDP-78/1950-H	160	111973	CBSCHD-2400-BT	112
91534	CBSBLD60C	112	103256	CBSHD-1800-BT	112	106271	MXDP-84/2100-H	160	111974	CBS18SC	112
91535	CBSBLD72C	112	103257	CBSHD-2100-BT	112	106272	MXDP-96/2400-H	160	111975	CBS24SC	112
91536	CBSBLD84C	112	103258	CBSHD-2400-BT	112	106273	MXDP-108/2700-H	160	111976	CBS30SC	112
91537	CBSBLD96C	112	103259	CBSHD-1500-BT	112	106274	MXDP-120/3000-H	160	111977	CBS36SC	112
91595	DVCR-CLR-EX73	125	103260	CBSHD-1800-BT	112	106548	MXDP-MPK	161	111978	CBS42SC	112
91596	DVCR-CLR-EX60	125	103261	CBSHD-2100-BT	112	106549	MXDP-MAK	161	111979	CBS48SC	112
91597	DVCR-CLR-ADT	125	103262	CBSHD-2400-BT	112	106569	CBS450P-S/S	114	111980	CBS54SC	112
91602	DVC-CLR1-AU	125	103602	RPA1200	128	106570	CBS600P-S/S	114	111981	CBS60SC	112
91603	DVCR-CLR-B31AU	125	103603	RPA1350	128	106571	CBS750P-S/S	114	111982	CBS72SC	112
91604	DVCR-CLR-B2C	125	103604	RPA1500	128	106572	CBS900P-S/S	114	111983	CBS54SC	112
91605	DVCR-CLR-BTR1	125	103605	RPA1800	128	106573	CBS1050P-S/S	114	111984	CBS96SC	112
91606	DVCR-CLR-TC2	125	103606	RPA1950	128	106574	CBS1200P-S/S	114	113390	YSTDBK2	51
91607	DVCR-CLR-TC3	125	103607	RPA2100	128	106575	CBS1350P-S/S	114	68171	EZIB600-1200L-LP	140
91608	DVCR-CLR-TC1	125	103608	RPA2400	128	106593	CBS-450-BT	112	68172	EZIB750-1200L-LP	140
91768	RBVP-SD-N	157	103971	DVC-SUB-U-AU	125	106594	CBS-600-BT	112	68173	EZIB900-1200L-LP	140
91769	RBVP-SD-S-600	157	104413	CBS450P	114	106595	CBS-750-BT	112	68174	EZIB1050-1200L-LP	140
91770	RBVP-SD-S-750	157	104414	CBS600P	114	106596	CBS-900-BT	112	68175	EZIB1200-1200L-LP	140
91771	RBVP-SD-S-900	157	104415	CBS750P	114	106597	CBS-1050-BT	112	68176	EZIB1350-1200L-LP	140
91772	RBVP-SD-S-1050	157	104416	CBS900P	114	106598	CBS-1200-BT	112	68177	EZIB1500-1200L-LP	140
91773	RBVP-SD-S-1200	157	104417	CBS1050P	114	106599	CBS-1350-BT	112	68178	EZIB1800-1200L-LP	140
91774	RBVP-SD-S-1350	157	104418	CBS1200P	114	106624	MXCP-SCK	161	68179	EZIB600-1500L-LP	140
91775	RBVP-SD-S-1500	157	104419	CBS1350P	114	106634	MXDPF-48/1200	161	68180	EZIB750-1500L-LP	140
91776	RBVP-SD-S-1800	157	105603	RBPMBK	163	106635	MXDPF-54/1350	161	68181	EZIB900-1500L-LP	140
91777	RBVP-SD-S-2000	157	105605	RBPFK-S	163	106636	MXDPF-60/1500	161	68182	EZIB1050-1500L-LP	140
91778	RBVP-SD-S-2200	157	105606	RBPFK-M	163	106637	MXDPF-66/1650	161	68183	EZIB1200-1500L-LP	140
91779	RBVP-SD-S-2400	157	105607	RBPFK-L	163	106638	MXDPF-72/1800	161	68184	EZIB1350-1500L-LP	140
91780	RBVP-SD-S-2600	157	105608	RBPFK-XL	163	106639	MXDPF-78/1950	161	68185	EZIB1500-1500L-LP	140
91781	RBVP-SD-S-2800	157	105613	RBPRET	163	106640	MXDPF-84/2100	161	68186	EZIB1800-1500L-LP	140
91782	RBVP-HD-N	157	105614	RBPRET-XL	163	106641	MXDPF-96/2400	161	68187	EZIB600-1200M-LP	143
91783	RBVP-HD-S-900	157	105621	RBPSR-S	163	106642	MXDPF-108/2700	161	68188	EZIB750-1200M-LP	143
91784	RBVP-HD-S-1050	157	105622	RBPSR-M	163	106643	MXDPF-120/3000	161	68189	EZIB900-1200M-LP	143
91785	RBVP-HD-S-1200	157	105623	RBPSR-L	163	107852	MSPBP	110	68190	EZIB1050-1200M-LP	143
91786	RBVP-HD-S-1350	157	105624	RBPSR-XL	163	108456	CBSC-450-BT	112	68191	EZIB1200-1200M-LP	143
91787	RBVP-HD-S-1500	157	105629	PSR-S-F	162	108457	CBSC-600-BT	112	68192	EZIB1350-1200M-LP	143
91788	RBVP-HD-S-1600	157	105630	PSR-M-F	162	108458	CBSC-750-BT	112	68193	EZIB1500-1200M-LP	143
91789	RBVP-HD-S-1800	157	105631	PSR-L-F	162	108459	CBSC-900-BT	112	68194	EZIB1800-1200M-LP	143
91790	RBVP-HD-S-2000	157	105632	PSR-XL-F	162	108460	CBSC-1050-BT	112	68195	EZIB600-1500M-LP	143
91791	RBVP-HD-S-2200	157	106063	MXDP-48/1200	160	108461	CBSC-1200-BT	112	68196	EZIB750-1500M-LP	143
91792	RBVP-HD-S-2400	157	106064	MXDP-54/1350	160	108462	CBSC-1350-BT	112	68197	EZIB900-1500M-LP	143
91793	RBVP-HD-S-2500	157	106065	MXDP-60/1500	160	108463	CBSCHD-1500-BT	112	68198	EZIB1050-1500M-LP	143
91794	RBVP-HD-S-2600	157	106066	MXDP-66/1650	160	108464	CBSCHD-1800-BT	112	68199	EZIB1200-1500M-LP	143
91795	RBVP-HD-S-2800	157	106067	MXDP-72/1800	160	108465	CBSCHD-2100-BT	112	68200	EZIB1350-1500M-LP	143
91796	RBVP-HD-S-3000	157	106068	MXDP-78/1950	160	108466	CBSCHD-2400-BT	112	68201	EZIB1500-1500M-LP	143

# INDEX By Item Code

Item Code	Ordering Number	Page #	Item Code	Ordering Number	Page #	Item Code	Ordering Number	Page #	Item Code	Ordering Number	Page #
68202	EZIB1800-1500M-LP	143	A2283	HBP900-TP	154	A2629	CBD-ST-TB-S/S	159	PTM-2000-1-S/S		169
A0012	WCB	119	A2284	HBP1050-TP	154	A2671	UNB73	37	PTM-2000-2		168
A0012	WCB	120	A2285	HBP1200-TP	154	A2704	RMC2-AP-S/S	174	PTM-2000-2-S/S		169
A0223	HBP750-B	153	A2286	HBP1400-TP	154	A2803	PPHD2100	59	PTM-2000-3		168
A0224	HBP900-B	153	A2287	HBP1500-TP	154	A2825	CRDLBLK-RH-S/S	79	PTM-2000-3-S/S		169
A0316	SB1200A	119	A2288	HBP1600-TP	154	A2825	CRDLBLK-RH-S/S	86	PTM-2400-1		168
A0317	SB1800	120	A2289	HBP1800-TP	154	A2825	CRDLBLK-RH-S/S	99	PTM-2400-1-S/S		169
A0334	SB1050	120	A2290	HBP2000-TP	154	A2826	CRDLBLK-LH-S/S	79	PTM-2400-2		168
A0407	SB750A	119	A2291	HBP2200-TP	154	A2826	CRDLBLK-LH-S/S	86	PTM-2400-2-S/S		169
A0408	SB750	120	A2292	HBP2400-TP	154	A2826	CRDLBLK-LH-S/S	99	PTM-2400-3		168
A0435	SB1050A	119	A2293	HBP2500-TP	154	A2829	MR-1500PG	132	PTM-2400-3-S/S		169
A0612	BP800-1050MF-S/S MAIN FRAME	153	A2294	HBP900-PL-TP	155	A2830	MR-1600PG	132	PTM-2600-1		168
A0613	BP800-1050-PL-S/S	153	A2295	HBP1050-PL-TP	155	A2831	MR-1800PG	132	PTM-2600-1-S/S		169
A0614	BP-LA-S/S	153	A2296	HBP1200-PL-TP	155	A2832	MR-2100PG	132	PTM-2600-2		168
A0615	BP-MB-S/S	153	A2297	HBP1400-PL-TP	155	A2833	MR-2400PG	132	PTM-2600-2-S/S		169
A0616	BP-SC-S/S	153	A2298	HBP1500-PL-TP	155	A2834	MR-2600PG	132	PTM-2600-3		168
A0617	BP-TL-S/S	153	A2299	HBP1600-PL-TP	155	A2835	MR-3000PG	132	PTM-2600-3-S/S		169
A0620	BP1200-1400MF-S/S MAIN FRAME	153	A2300	HBP1800-PL-TP	155	A2836	MR-450PG	132	PTM-3000-1		168
A0621	BP1200-1400-PL-S/S	153	A2301	HBP2000-PL-TP	155	A2837	MR-600PG	132	PTM-3000-1-S/S		169
A0646	BP1500-1600MF-S/S MAIN FRAME	153	A2302	HBP2400-PL-TP	155	A2838	MR-750PG	132	PTM-3000-2		168
A0647	BP1500-1600-PL-S/S	153	A2303	HBP2200-PL-TP	155	A2839	MR-900PG	132	PTM-3000-2-S/S		169
A0682	BP450-750MF-S/S MAIN FRAME	153	A2304	HBP2500-PL-TP	155	A2840	MR-1050PG	132	PTM-3000-3		168
A0683	BP450-750-PL-S/S	153	A2305	HBP900-MF-TP	155	A2841	MR-1200PG	132	PTM-3000-3-S/S		169
A0696	SB900	120	A2306	HBP1050-MF-TP	155	A2842	SMR-CCB-L73	77	PTM-750-1		168
A0827	SB1400	120	A2307	HBP1200-MF-TP	155	A2842	SMR-CCB-L73	84	PTM-750-1-S/S		169
A0863	SB1200	120	A2308	HBP1400-MF-TP	155	A2842	SMR-CCB-L73	97	PTM-750-2		168
A0886	SB600	120	A2309	HBP1500-MF-TP	155	A2842	SMR-CCB-L73	132	PTM-750-2-S/S		169
A0887	SB600A	119	A2310	HBP1600-MF-TP	155	A2843	SMR-CCB-R73	77	PTM-750-3		168
A0912	SB900A	119	A2311	HBP1800-MF-TP	155	A2843	SMR-CCB-R73	84	PTM-750-3-S/S		169
A1155	HBP-MB-TP-S/S	155	A2312	HBP2000-MF-TP	155	A2843	SMR-CCB-R73	97	PTM-900-1		168
A1357	SB1800A	119	A2313	HBP2400-MF-TP	155	A2843	SMR-CCB-R73	132	PTM-900-1-S/S		169
A1436	FLSC2000-S/S	173	A2314	HBP2200-MF-TP	155	A2844	SMR-CCB-L60	132	PTM-900-2		168
A1437	FLSC-TP-S/S	173	A2315	HBP2500-MF-TP	155	A2845	SMR-CCB-R60	132	PTM-900-2-S/S		169
A1438	FLSC-CP-S/S	173	A2316	HBP900-B-TP	155	A2988	EZP1P24-S/S	17	PTM-900-3		168
A1439	FLSC2000-CB-S/S	173	A2317	HBP1050-B-TP	155	A3041	EZP1P30-S/S	17	PTM-900-3-S/S		169
A1440	FLSC2000-MC-S/S	173	A2318	HBP1200-B-TP	155	A3119	EZP1P36-S/S	17			
A1535	SB-MB-S/S	120	A2319	HBP1400-B-TP	155	B0092	CBD-ST-MC	57			
A1536	SB-UC38-S/S	120	A2320	HBP1500-B-TP	155	B0536		159			
A1546	BP1800MF-S/S MAIN FRAME	153	A2321	HBP1600-B-TP	155	G1211	HEX NUT	35			
A1547	BP1800-PL-S/S	153	A2322	HBP1800-B-TP	155	G1211	HEX NUT	71			
A1575	RPHD1800-S/S	61	A2323	HBP2000-B-TP	155	G1211	HEX NUT	91			
A1588	HXFHD1800M-S/S	31	A2324	HBP2400-B-TP	155	GN812	UST	104			
A1589	HXFHD1800L-S/S	31	A2325	HBP2200-B-TP	155	GN812	UST	105			
A1590	HXFHD2100M-S/S	31	A2326	HBP2500-B-TP	155	GR298		57			
A1591	HXFHD2100L-S/S	31	A2330	HBP-LA-TP	155	GR660	SSTXDM	114			
A1592	HXFHD2400M-S/S	31	A2474	HBP-TP-900 S/S	154	U8393	PBC1 Case	134			
A1593	HXFHD2400L-S/S	31	A2475	HBP-TP-1050 S/S	154	U8394	PBC2 Case	134			
A1594	HVHD1800M-S/S	32	A2476	HBP-TP-1200 S/S	154		PTM-1050-1	168			
A1595	HVHD1800L-S/S	32	A2477	HBP-TP-1400 S/S	154		PTM-1050-1-S/S	169			
A1596	HVHD1800LL-S/S	32	A2478	HBP-TP-1500 S/S	154		PTM-1050-2	168			
A1597	HVHD2100M-S/S	32	A2479	HBP-TP-1600 S/S	154		PTM-1050-2-S/S	169			
A1598	HVHD2100L-S/S	32	A2480	HBP-TP-1800 S/S	154		PTM-1050-3	168			
A1599	HVHD2100LL-S/S	32	A2481	HBP-TP-2000 S/S	154		PTM-1050-3-S/S	169			
A1600	HVHD2400M-S/S	32	A2482	HBP-TP-2200 S/S	154		PTM-1200-1	168			
A1601	HVHD2400L-S/S	32	A2483	HBP-TP-2400 S/S	154		PTM-1200-1-S/S	169			
A1602	HVHD2400LL-S/S	32	A2484	HBP-TP-2500 S/S	154		PTM-1200-2	168			
A1603	PVHD1800-S/S	58	A2492	HBP900-PL-TP-S/S	155		PTM-1200-2-S/S	169			
A1604	PVHD2100-S/S	58	A2493	HBP1050-PL-TP-S/S	155		PTM-1200-3	168			
A1605	PVHD2400-S/S	58	A2494	HBP1200-PL-TP-S/S	155		PTM-1200-3-S/S	169			
A1610	RVHD2400-S/S	60	A2495	HBP1400-PL-TP-S/S	155		PTM-1350-1	168			
A1613	PPHD2100-S/S	59	A2496	HBP1500-PL-TP-S/S	155		PTM-1350-1-S/S	169			
A1620	SB1400A	119	A2497	HBP1600-PL-TP-S/S	155		PTM-1350-2	168			
A1626	RVHD1800-S/S	60	A2498	HBP1800-PL-TP-S/S	155		PTM-1350-2-S/S	169			
A1628	RVHD2100-S/S	60	A2499	HBP2000-PL-TP-S/S	155		PTM-1350-3	168			
A1629	RPHD2100-S/S	61	A2500	HBP2200-PL-TP-S/S	155		PTM-1350-3-S/S	169			
A1775	PPHD2400-S/S	59	A2501	HBP2400-PL-TP-S/S	155		PTM-1500-1	168			
A1776	SB2400	120	A2502	HBP2500-PL-TP-S/S	155		PTM-1500-1-S/S	169			
A1781	PPHD1800-S/S	59	A2504	HBP900-MF-TP-S/S	155		PTM-1500-2	168			
A1783	HPHD2000-S/S	37	A2505	HBP1050-MF-TP-S/S	155		PTM-1500-2-S/S	169			
A1784	CBD-ST-XL-FR-B	159	A2506	HBP1200-MF-TP-S/S	155		PTM-1500-3	168			
A1838	SB1500A	119	A2507	HBP1400-MF-TP-S/S	155		PTM-1500-3-S/S	169			
A1854	CBD-M-S/S	158	A2508	HBP1500-MF-TP-S/S	155		PTM-1600-1	168			
A1856	CBD-L-S/S	158	A2509	HBP1600-MF-TP-S/S	155		PTM-1600-1-S/S	169			
A1996	BP2000MF	153	A2510	HBP1800-MF-TP-S/S	155		PTM-1600-2	168			
A2033	SB1500	120	A2511	HBP2000-MF-TP-S/S	155		PTM-1600-2-S/S	169			
A2046	PVHD2000-S/S	58	A2512	HBP2200-MF-TP-S/S	155		PTM-1600-3	168			
A2063	HPHD1800-S/S	37	A2513	HBP2400-MF-TP-S/S	155		PTM-1600-3-S/S	169			
A2120	PPHD2000-S/S	59	A2514	HBP2500-MF-TP-S/S	155		PTM-1800-1	168			
A2138	CBD-ST-XL-S/S	159	A2515	HBP-LA-TP-S/S	155		PTM-1800-1-S/S	169			
A2189	HBP-SC-TP-S/S	155	A2518	HDSTKD	37		PTM-1800-2	168			
A2189	HDSTCK-S/S	37	A2519	HDSTKD-S/S	37		PTM-1800-2-S/S	169			
A2215	CBD-ST-CS-S/S	159	A2527	RPHD2100	61		PTM-1800-3	168			
A2218	CBD-ST-L-FR-B	159	A2590	HPHD2400-S/S	37		PTM-1800-3-S/S	169			
A2237	HBP1050-B	153	A2596	FLSCM-CP-S/S	173		PTM-2000-1	168			

# INDEX By Item Code

Item Code	Ordering Number	Page #	Item Code	Ordering Number	Page #	Item Code	Ordering Number	Page #	Item Code	Ordering Number	Page #









---

*Partners in Productivity*

10 Solent Circuit  
Norwest NSW 2153

**Phone: +61 2-8818-2000 Fax: +61 2-8824-6333**

**Toll Free: 1300 098 435**

**E-mail: [salesau@flexco.com](mailto:salesau@flexco.com)**

**[www.flexco.com](http://www.flexco.com)**