

# STP Assembly Guide (Kit 101808) for Wide Flange Transfer Plate Bracket Installation

## Instructions for Installation

Kit 101808 is intended for STP installations on conveyors where there is no structure available or where there is limited installation area. For full installation details, reference the Segmented Transfer Plate IOMs X4064 and X6041. Kit 101808 contains one pair of brackets and installation hardware.

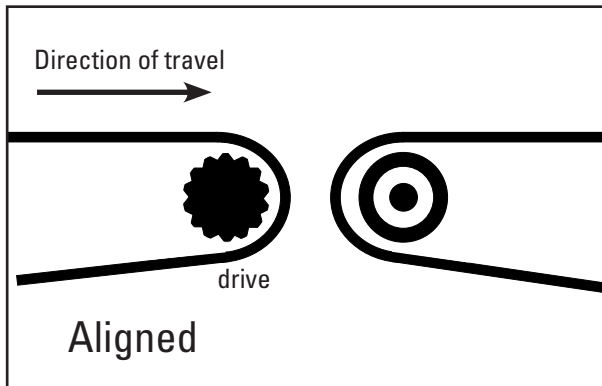

1. Determine location of transfer plate.

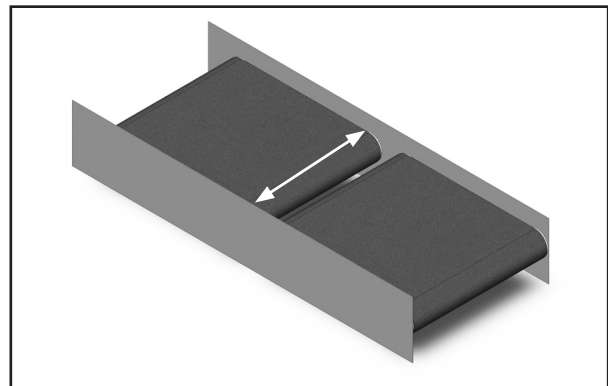

2. Measure the inside structure width to determine the placement of the bracket.

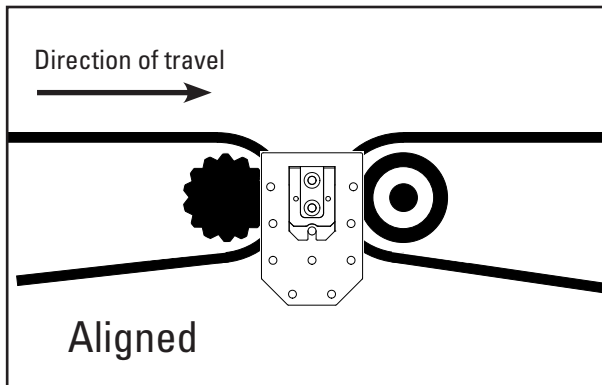

3. Insert support bar and brackets as per X4064. Use the adhesive backing to place the brackets into position.

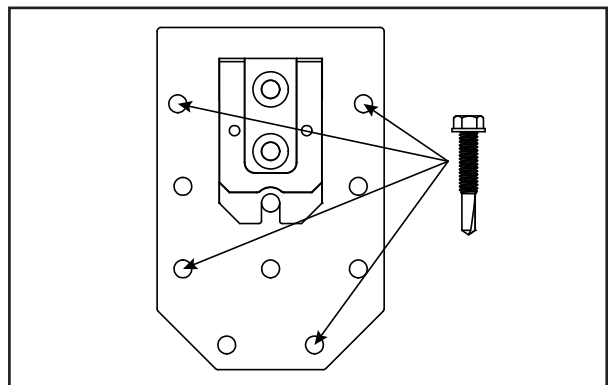

4. Secure the bracket with at least four fasteners.

5. Assemble the mounting bar, two pairs of center segments, and a mounting bracket on each end of the bar as per X4064.



2525 Wisconsin Avenue • Downers Grove, IL 60515-4200 • USA  
Tel: (630) 971-0150 • Fax: (630) 971-1180 • E-mail: info@flexco.com

Visit [www.flexco.com](http://www.flexco.com) for other Flexco locations and products.

©2021 Flexible Steel Lacing Company. 09-27-21. For Reorder: 101899

