



Product Guide

EFFECTIVE JULY 1, 2020

BCPPGAUS

Belt Conveyor Products



10 Solent Circuit
Norwest NSW 2153

Phone: +61 2-8818-2000 Fax: +61 2-8824-6333

Toll Free: 1300 098 435

E-mail: salesau@flexco.com

www.flexco.com

INFORMATION

HEAD OFFICE ADDRESS: Flexco® (Aust.) Pty Ltd
10 Solent Circuit
Baulkham Hills, NSW 2153

OFFICE TELEPHONE: +61 2 8818-2000

WESTERN AUSTRALIA OFFICE ADDRESS: Unit 1/13 Ernest Clark Rd.
Canning Vale, WA 6155
Phone: 08 6253-8081
Fax: 08 9456-2571

BUNDABERG OFFICE ADDRESS: 49 Hanbury Street, Bundaberg, QLD
4670 Australia
Ph: 07 4151-0359
F: 07 4151-0568

POSTAL ADDRESS: P.O. Box 6365
Baulkham Hills B.C. NSW 2153

EMAIL: salesau@flexco.com
marketingau@flexco.com

OFFICE FACSIMILE: +61 2 8824-6333

TERMS AND CONDITIONS: Prices are in AUD exclusive of GST.

1. Stock items (non-shaded) please refer to asterisk (*) for specific lead time, if not specified, standard 2-3 days lead-time applies.
2. Some assembled items and larger quantities may take longer, please contact Flexco for specifics.
3. Non-stock items (shaded) please contact Flexco for dispatch options and lead times.
4. Minimum order size for free shipping is \$4,000 net, excluding GST. Free shipping is not applicable to orders delivered to third parties.
5. Strictly Net 30 days unless otherwise negotiated.
6. 3rd party deliveries may be refused—please contact customer service.
7. Flexco endeavours to hold adequate stock levels at all times, however fluctuations do occur; stock is subject to availability.
8. All product refunds are subject to quality approvals before processing and may incur a restocking fee.

LIMITED LIABILITY: Every effort is made to ensure the information contained in this price book is accurate and in accordance with all current specifications, however the company cannot be held responsible for any errors and reserves the right, without prior notice, to change specifications, quantities, and prices.

Visit our Website at: www.flexco.com

Table of Contents

Belt Cleaners

Belt Cleaner Information and Selection Guide 5

Primary Cleaners

EZP-LS Limited Space Primary Cleaner	10
EZP1 Primary Cleaner & ConShear™ Replacement Blades	15
EZP1T Twist Tensioner Primary Cleaner	20
Spring Covers and Tensioner Lock	22
MMP Medium-Duty Primary Cleaner & TuffShear™ Replacement Blades	23
Line Connections for Portable Air Tensioner	29
MHCP Heavy-Duty Cartridge Primary Cleaner & SuperShear™ Replacement Blades	30
H-Type® Primary Cleaners.....	36
H-Type® ESAC Heavy-Duty Primary Cleaner.....	44
H-Type® ESAC with Extra Life -V-Tips Heavy-Duty Primary Cleaner.....	50

Secondary Cleaners

Y-Type® Secondary Cleaners.....	56
P-Type® Secondary Cleaners	65
R-Type® Reversing Secondary Cleaners	67
FMS Medium-Duty Secondary Cleaners	69
MHS Heavy-Duty Secondary Cleaners.....	72
Spring Covers and Tensioner Lock	81
Cartridge Cleaners:	
P-Type Secondary Cleaners with Service Advantage Cartridge™.....	82
R-Type Secondary Cleaners with Service Advantage Cartridge.....	89
MHS Heavy-Duty Secondary Cleaners with Service Advantage Cartridge	96
Spring Covers and Tensioner Lock	109
U-Type® Secondary Cleaners	110
MDWS DryWipe Secondary Cleaner	116
Motorised Brush Cleaner	120
Chevron Belt Cleaner	123
Wash Box.....	124
Universal Lightweight Pole	125

Belt Cleaner Accessories

Inspection Doors.....	126
Spray Pole Systems.....	128
Mandrel Safety Removal System.....	130
Live Shaft Hold Down Rollers	131
Standard Pulley Lifter.....	132
Belt Cleaner Accessories.....	133
Optional Mounting Kits	134

Impact Beds

Flexco® Slider and Impact Beds

EZSB-C and EZSB-I Slider Beds; EZIB-L and EZIB-M Impact Beds	136
--	-----

DRX® Impact Beds

DRX200 - DRX1500 Impact Beds.....	145
DRX3000 Dynamic Bed.....	148
Optional Parts and Tools.....	149

Belt Conveyor Products

Ploughs

V-Plough	150
Twin Pole V-Plough.....	152
HD® Floating V-Plough	154
Diagonal Plough	156
HD Spring-Tensioned Diagonal Plough.....	157

Table of Contents

Belt Positioners and Trainers

Belt Positioner™	158
PTEZ	160
PT Smart™ Belt Trainer	164
PT Max™ Belt Trainer	167

Skirting Systems

Skirt Clamps-RMC1, Flex-Lok™, and FlexSeal™	170
Dual Seal Polyurethane Skirting	171
Standard Urethane Skirting	172
Enclosed Skirt System	173

Belt Maintenance Tools

Flex-Lifter™	176
Electric and Pneumatic Belt Cutters	176

Index	177
--------------------	------------

Belt Cleaner Information and Selection Guide

Why Are Belt Cleaners Needed?

- **Reduces Maintenance Costs**
 - Minimises manual cleanup.
 - Protects against belt mistracking.
 - Reduces conveyor component replacement costs.
 - Reducing carryback means a reduction in maintenance costs.
- **Improves Safety**
 - Reduces housekeeping problems.
 - A majority of conveyor-related accidents happen while maintenance tasks are being done.
- **Keeps Conveyors Running Efficiently and Consistently**
 - Reduces unscheduled downtime.
 - Increases production uptime.
- **Saves Money**
 - Increases belt wear life.
 - Extends life of rollers, pulleys and splices.
 - High cost of accidents.



Types of Belt Cleaners

- **Primary Cleaners**
 - Mounted on the head pulley.
 - Mounted below the material flow.
 - Removes the big stuff. Typically cleans off up to 80% of the initial carryback.
- **Secondary Cleaners**
 - Located just past where the belt leaves the head pulley and anywhere down the beltline.
 - Special secondaries may allow for mounting under the head pulley.
 - Removes sticky fines – the final cleaning job.
 - May require a hold-down roller for maximum performance.
- **Specialty Cleaners**
 - Primary Cleaners or Secondaries designed especially for specific or extreme applications.

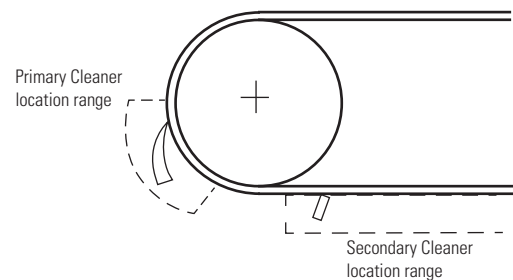

Definition of Terms

- **Carryback**—Material that sticks to the belt after it leaves the transfer point and continues falling off along the conveyor's return side.
- **Material Path**—The section of the belt where most of the material is conveyed. Typically the center 2/3 of the belt.
- **Hold-Down Roller**—A stabilising roller or pressure roller located on top of the return side of the belt to prevent belt flap or to provide a consistent flat surface for the blades on a lighter-tensioned belt.

Types of Cleaner Blades

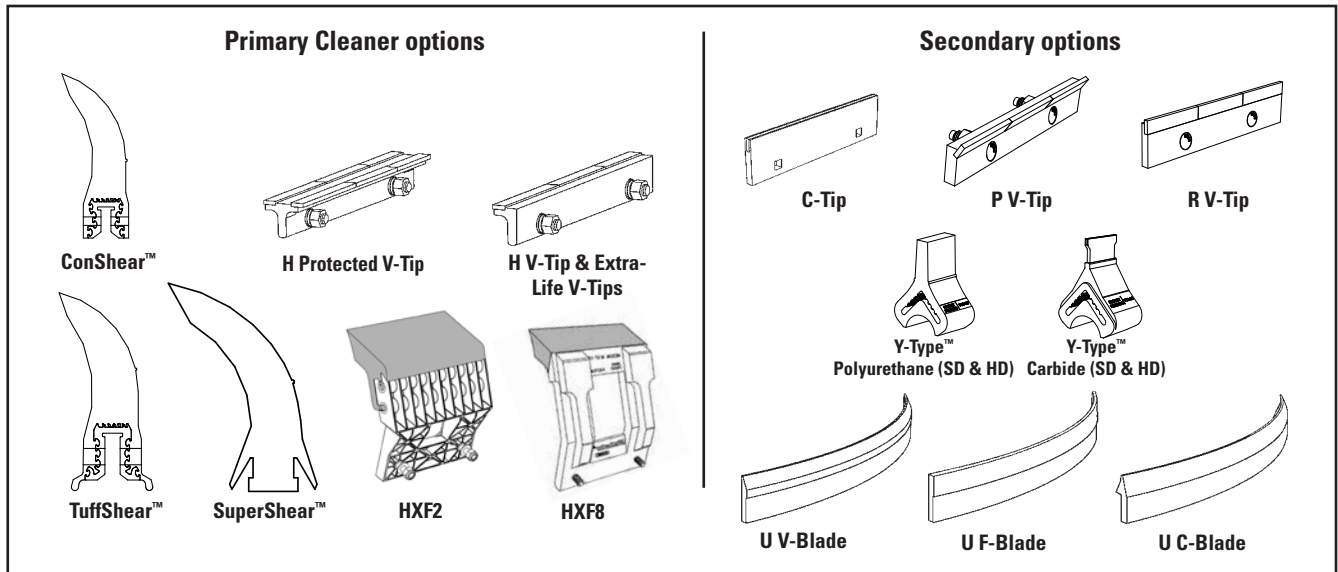

F-Tip/Blade - for mechanically fastened belts **V-Tip/Blade** - for vulcanised belts only **C-Tip/Blade** - for both

Polyurethane Blades

Not all polyurethanes are the same. Flexco's polyurethane blades are specially formulated for abrasion resistance and long wear. Independent testing has shown that Flexco's polyurethane blades last as much as 30% longer than other OEM blades.

- Easy on the belt.
- Work well with mechanical splices.
- Economical.
- Specialty formulations for high heat, chemical resistance, or water removal.
- FRAS for underground applications.



Less advanced polyurethane formulations result in blades that experience quicker wear and provide less-efficient cleaning.

Tungsten Carbide

Excellent for superior cleaning efficiency and long wear. The quality and application of carbides can vary. Flexco® has invested years of research and testing to develop tungsten carbide tips for both vulcanised and mechanically fastened belts. And a quality process ensures consistent results.

- Superior cleaning.
- Long wear.
- C-Tips/blades for mechanical splices and V-Tips/blades for vulcanised belts.

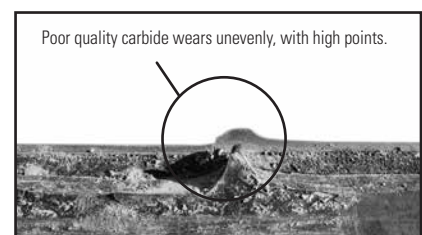

Blade Angle (Secondary cleaners)

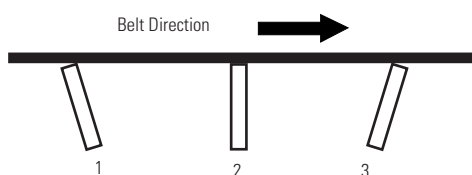

1. Aggressive - excellent cleanability, high risk for belt damage.
2. 90° to belt - good cleaning efficiency; must have good blade relief for splices (Flexco recommended).
3. Wiping - a little less cleaning power; safer on belts in poor condition or with poor mechanical splices.

Belt Cleaning Systems

Keys to Good Belt Cleaning

- Proper cleaner selection for the application
- Correct installation
- Regular service maintenance

Spec'ing and Ordering Belt Cleaners

Information needed:

- A.** Belt Width
- B.** Conveyor frame (structure) width
- C.** Head pulley diameter
- D.** For Primary Cleaners - what is the belt's material path
- E.** Material conveyed (dry, wet, sticky, etc.)
- F.** Type of belt splice:
 - Mechanical - skived or unskived
 - Vulcanised
- G.** Temperature or other extreme environmental factors
- H.** Does the belt reverse

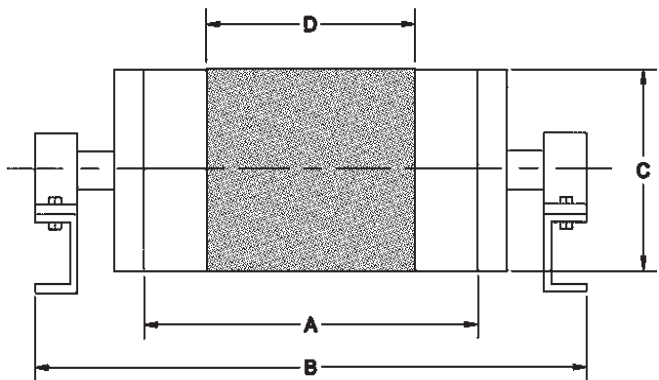

Primary Cleaner Selection Guide









Primary Cleaner Specification Chart

APPLICATION DESCRIPTION	EZP-LS	EZP1, HIGH TEMP EZP1	MMP	MHP	MHCP	H-TYPE® (HFX2, XF, XF8)	H-TYPE® (V)
Belt Width*	300 - 1500 mm	300 - 1800 mm	600 - 2100 mm	600 - 2400 mm	600 - 2100 mm	450 - 3200 mm	450 - 3200 mm
Head Pulley Diameter	150 - 550 mm	250 - 900 mm	400 - 1200 mm	500 - 1200 mm	500 - 1200 mm	250 - 1325 mm	250 - 1575 mm
Reversing Belts	Yes	Yes	Yes	Yes	Yes	Yes	Yes
Mechanical Fasteners	Yes	Yes	Yes	Yes	Yes	Yes	No







*Special sizes available upon request.

Contact Flexco® for pulleys over 1700 mm diameter.

Primary Cleaner Blade Specifications

									
Blade Type	ConShear™ LS	ConShear™ LS High Temp	ConShear™ LS White (Chemical Resistant/Food Grade) ‡	ConShear™	ConShear™ High Temp	ConShear™ White (Chemical Resistant/Food Grade) ‡	ConShear Ultra High Temp	TuffShear™	MegaShear™
Temperature Range	-30 to 180°F (-35 to 82°C)	up to 275°F (135°C) with spikes to 325°F (163°C)	-30 to 180°F (-35 to 82°C)	-30 to 180°F (-35 to 82°C)	up to 275°F (135°C) with spikes to 325°F (163°C)	-30 to 180°F (-35 to 82°C)	up to 200°C (400°F) with spikes to 232°C (450°F)	-30 to 180°F (-35 to 82°C)	-30 to 180°F (-35 to 82°C)
Polyurethane	Yes	Yes	Yes	Yes	Yes	Yes	Yes	Yes	Yes
Durometer	83	93	83	83	93	83	90	83	90
Tungsten Carbide	No	No	No	No	No	No	No	No	No
Work with Mechanical Fasteners	Yes	Yes	Yes	Yes	Yes	Yes	Yes	Yes	Yes
FRAS	Contact Flexco								

Primary Cleaner Blade Specifications (cont.)

						
BLADE TYPE	SuperShear™	HXF	HXF2	H V-TIP	H PROTECTED V-TIP	Extra Life V-Tips
Temperature Range	-30 to 180°F (-35 to 82°C)	-35 to 82°C	-35 to 82°C	-35 to 205°C	-35 to 205°C	-35 to 205°C
Polyurethane	Yes	Yes	Yes	No	No	No
Durometer	90	84	83	N/A	N/A	N/A
Tungsten Carbide	No	No	No	Yes	Yes	Yes
Work with Mechanical Fasteners	Yes	Yes	Yes	No	No	No
FRAS		Yes	No	N/A	N/A	N/A

For Belt Speed information please consult your Flexco® representative

U.S. Patent No. 9,242,805; D756,060; D747,838

Secondary Cleaner Selection Guide

Secondary Cleaner Specification Chart

APPLICATION DESCRIPTION	MHS (C-TIP)	MHS (V-TIP)	P-TYPE® (C-TIP)	P-TYPE (V-TIP)	P-TYPE-LS (C-TIP)	Y-Type SD Polyurethane	Y-Type SD Carbide	Y-Type HD Polyurethane	Y-Type HD Carbide
Belt Width*	600-3000mm	600-3000mm	450-3000mm	450-3000mm	450-3000mm	450-1200mm	450-1200mm	900-1800mm	900-1800mm
Secondary Cleaner Blade Options	Yes	Yes	No	No	No	Yes	Yes	Yes	Yes
Work with Mechanical Fasteners	Yes	No	Yes	No	Yes	Yes	Yes	Yes	Yes

*Special sizes available upon request.
Contact Flexco® for belt widths over 3000 mm diameter.

Secondary Cleaner Specification Chart (cont.)

APPLICATION DESCRIPTION	U-TYPE® (F-BLADE)	U-TYPE (C-BLADE)	U-TYPE (V-BLADE)	R-TYPE® (C-TIP)	R-TYPE (V-TIP)	CHEVRON	Brush Cleaner
Belt Width*	450-3000mm	450-3000mm	450-3000mm	450-3000 mm	450-3000 mm	450-1500mm	450-2100 mm
Secondary Cleaner Blade Options	No	No	No	Yes	Yes	Yes	Yes
Work with Mechanical Fasteners	Yes	Yes	No	Yes	No	Yes	Yes

*Special sizes available upon request.
Contact Flexco for belt widths over 3000 mm diameter.

Secondary Cleaner Blade Specifications

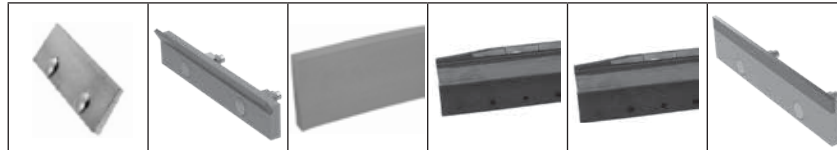

BLADE TYPE	C-TIP	P V-TIP	U F-BLADE	U C-BLADE	U V-BLADE	R V-TIP
Temperature Range	-35 to 205°C	-35 to 205°C	-35 to 82°C	-35 to 82°C	-35 to 82°C	-35 to 205°C
Polyurethane	No	No	Yes	Rubber	Rubber	No
Durometer	N/A	N/A	90	84	83	N/A
Tungsten Carbide	Yes	Yes	No	Yes	Yes	Yes
Work with Mechanical Fasteners	Yes	No	Yes	Yes	No	No

Secondary Cleaner Blade Specifications cont.

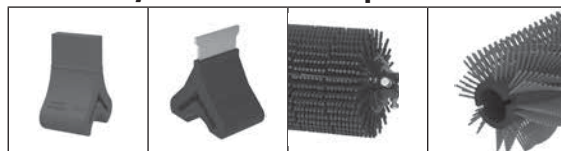

BLADE TYPE	Y-Type Polyurethane	Y-Type Carbide	Chevron	Brush Cleaner
Temperature Range	-35 to 82°C	-35 to 82°C	-35 to 82°C	-30 to 82°C
Polyurethane	Yes	No	Rubber	Polypropylene
Durometer	86A	N/A	N/A	N/A
Tungsten Carbide	YNo	Yes	No	No
Work with Mechanical Fasteners	Yes	Yes	Yes	Yes

For Belt Speed information please consult your Flexco® representative

Product Ordering Information

EZP-LS Limited Space Primary Cleaner and Stainless Steel Limited Space Primary Cleaner



EZP-LS Primary Cleaner Belt Width Minus 50mm

BELT WIDTH mm	BLADE COVERAGE mm	ORDERING NUMBER	ITEM CODE	WT. KG.
300	250	EZP-LS212	77127	11.3
450	400	EZP-LS218	77128	12.8
600	550	EZP-LS224	77129	14.4
750	700	EZP-LS230	77130	16.0
900	850	EZP-LS236	77131	17.6
1050	1000	EZP-LS242	77132	19.1
1200	1150	EZP-LS248	77133	20.7
1350	1300	EZP-LS254	77134	22.2
1500	1450	EZP-LS260	77135	23.9

EZP-LS High-Temp Primary Cleaner Belt Width Minus 2" (50mm)

BELT WIDTH		BLADE WIDTH		ORDERING NUMBER	ITEM CODE	WT. KG.
in.	mm	in.	mm			
12	300	10	250	EZP-LS212HT	77746	24.8
18	450	16	400	EZP-LS218HT	77747	28.2
24	600	22	550	EZP-LS224HT	77748	31.7
30	750	28	700	EZP-LS230HT	77749	35.1
36	900	34	850	EZP-LS236HT	77750	38.6
42	1050	40	1000	EZP-LS242HT	77751	42.0
48	1200	46	1150	EZP-LS248HT	77752	45.5
54	1350	52	1300	EZP-LS254HT	77753	48.9
60	1500	58	1450	EZP-LS260HT	77754	52.5

Stock items (non-shaded) refer to (*) for specific lead time, if not specified, standard lead time applies.

Non-stock items (shaded) please contact Flexco for dispatch options and lead times.

U.S. Patent No. D482,508S; 9,242,805; D756,060; D747,838 (blade)

U.S. Patent No. 8,662,283 (tensioner)

EZP-LS Stainless Steel Primary Cleaner Belt Width Minus 50mm (2")

BELT WIDTH mm	BLADE COVERAGE mm	ORDERING NUMBER	ITEM CODE	WT. KG.
300	250	EZP-LS212-S/S	62836	11.3
450	400	EZP-LS218-S/S	62837	12.8
600	550	EZP-LS224-S/S	62838	14.4
750	700	EZP-LS230-S/S	62839	16.0
900	850	EZP-LS236-S/S	62840	17.6
1050	1000	EZP-LS242-S/S	62841	19.1
1200	1150	EZP-LS248-S/S	62842	20.7
1350	1300	EZP-LS254-S/S	62843	22.2
1500	1450	EZP-LS260-S/S	62844	23.9

Lead time: 4 weeks

EZP-LS Stainless Steel High-Temp Primary Cleaner Belt Width Minus 50mm (2")

BELT WIDTH mm	BLADE COVERAGE mm	ORDERING NUMBER	ITEM CODE	WT. KG.
300	250	EZP-LS212HT-S/S	62845	11.3
450	400	EZP-LS218HT-S/S	62846	12.8
600	550	EZP-LS224HT-S/S	62847	14.4
750	700	EZP-LS230HT-S/S	62848	16.0
900	850	EZP-LS236HT-S/S	62849	17.6
1050	1000	EZP-LS242HT-S/S	62850	19.1
1200	1150	EZP-LS248HT-S/S	62851	20.7
1350	1300	EZP-LS254HT-S/S	62852	22.2
1500	1450	EZP-LS260HT-S/S	62853	23.9

Lead time: 4 weeks

EZP-LS Stainless Steel Primary Cleaner with White ConShear LS Blade Belt Width Minus 50mm (2")

BELT WIDTH mm	BLADE COVERAGE mm	ORDERING NUMBER	ITEM CODE	WT. KG.
300	250	CLSFG-212	77144	11.3
450	400	CLSFG-218	77145	12.8
600	550	CLSFG-224	77146	14.4
750	700	CLSFG-230	77147	16
900	850	CLSFG-236	77148	17.5
1050	1000	CLSFG-242	77149	19.1
1200	1150	CLSFG-248	77150	20.7
1350	1300	CLSFG-254	77151	22.2
1500	1450	CLSFG-260	77152	23.9

Specifications & Guidelines

EZP-LS Limited Space Primary Cleaner

Pole Length Specifications*

CLEANER SIZE mm	POLE LENGTH mm	MAXIMUM CONVEYOR SPAN mm
300	1050	925
450	1200	1075
600	1350	1225
750	1500	1375
900	1650	1525
1050	1800	1675
1200	1950	1825
1350	2200	2075
1500	2350	2225
1800	2650	2525

Pole Diameter - 48 mm

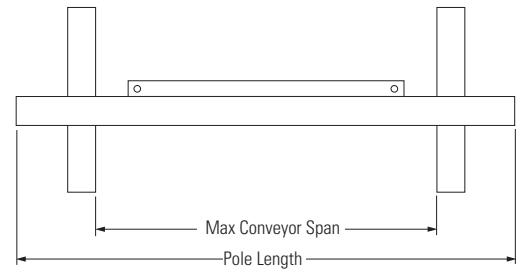

Clearance Guidelines for Installation

HORIZONTAL CLEARANCE REQUIRED mm	VERTICAL CLEARANCE REQUIRED mm
75	165

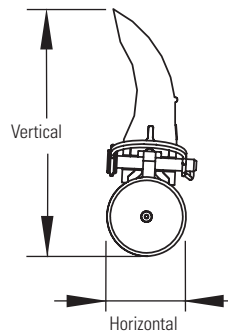

Pole Location Specs

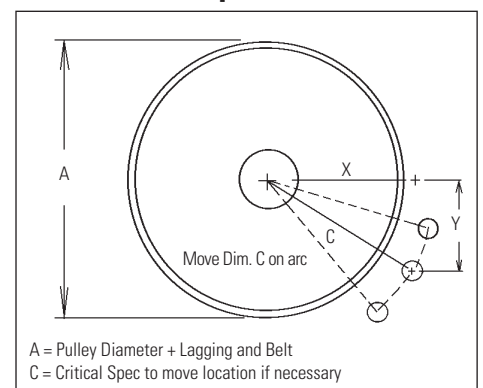

Spring Length Chart with LST Spring Tensioner

BLADE WIDTH mm	PURPLE SPRING mm	SILVER SPRING mm	BLACK SPRING mm
254	51	N/A	N/A
406	41	54	N/A
559	N/A	51	N/A
711	N/A	48	N/A
864	N/A	44	N/A
1016	N/A	38	N/A
1168	N/A	35	51
1321	N/A	N/A	51
1473	N/A	N/A	48

Shading indicates preferred spring option

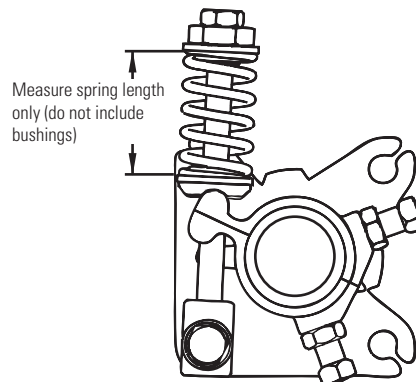

Pole Location Chart

A	X	Y	C
152	67	140	156
178	83	140	162
203	99	140	171
229	111	140	178
254	127	140	187
279	140	140	197
305	156	140	210
330	168	140	219
356	181	140	229
381	194	140	238
406	210	140	251
432	222	140	264
457	235	140	273
483	248	140	286
508	260	140	295
533	273	140	308
559	286	140	318

Specifications:

- Maximum Belt SpeedContact Flexco®
- Temperature Rating-35°C to 82°C
- Minimum Pulley Diameter.....150 mm
- Blade Height.....115 mm
- Usable Blade Wear Length.....60 mm
- BladePolyurethane (proprietary blend for abrasion resistance and long wear)
- Available for Belt Widths300 to 1800 mm

Replacement Parts List

EZP-LS Limited Space Primary Cleaner

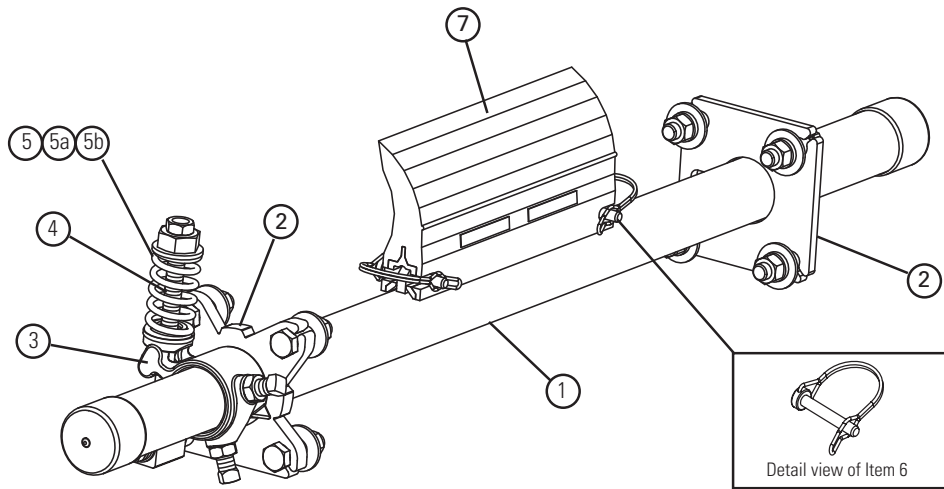

Replacement Parts

REF	DESCRIPTION	ORDERING NUMBER	ITEM CODE	WT. KG.
1	300 mm Pole	LSP12	77070	6.0
	450 mm Pole	LSP18	77071	7.0
	600 mm Pole	LSP24	77072	8.0
	750 mm Pole	LSP30	77073	9.0
	900 mm Pole	LSP36	77074	10.0
	1050 mm Pole	LSP42	77075	11.0
	1200 mm Pole	LSP48	77076	12.0
	1350 mm Pole	LSP54	77077	13.0
	1500 mm Pole	LSP60	77078	14.1
2	Mounting Plate Kit* (incl. 1 tensioner mounting plate and 1 pole mounting plate)	LSTMPK	77366	1.6
3	Torque Arm Kit* (1 ea.)	LST-TAK	77120	0.6
4	Pivot Block/Rod Kit* (1 ea.)	LSTPB-RK	77367	0.4
5	Tension Spring - Purple (1 ea.) for blades 250-400 mm	LS-SP	77365	0.1
5a	Tension Spring - White (1 ea.) for blades 550 - 1150 mm	LS-SW	77117	0.1
5b	Tension Spring - Silver (1 ea.) for blades 1300 - 1450 mm	LS-SS	77118	0.1
6	LS Blade Pin (1 ea.)	LS-BP	77114	0.05
-	LST Spring Tensioner* - Purple incl. 1 tensioner mounting plate and 1 ea. items 3, 4 & 5 for blades 250-400 mm	LST-P	77121	3.4
-	LST Spring Tensioner* - White incl. 1 tensioner mounting plate and 1 ea. items 3, 4 & 5a for blades 550 - 1150 mm	LST-W	77122	3.5
-	LST Spring Tensioner* - Silver incl. 1 tensioner mounting plate and 1 ea. items 3, 4 & 5b for blades 1300 - 1450 mm	LST-S	77123	3.5

Hardware Included

Spring Tensioner Selection Chart

CLEANER BLADE WIDTH	77121 PURPLE	77122 WHITE	77123 SILVER
ConShear-LS 250 - 400 mm	X		
ConShear-LS 550 - 1150 mm		X	
ConShear-LS 1300 - 1450 mm			X

 **Stock items** (non-shaded) refer to (*) for specific lead time, if not specified, standard lead time applies.

 **Non-stock items** (shaded) please contact Flexco for dispatch options and lead times.

U.S. Patent No. D482,508S; 9,242,805; D756,060; D747,838 (blade)

U.S. Patent No. 8,662,283 (tensioner)

For best results use Flexco® Genuine Replacement Blades and Parts.

Replacement Parts List

EZP-LS Stainless Steel Limited Space Primary Cleaner

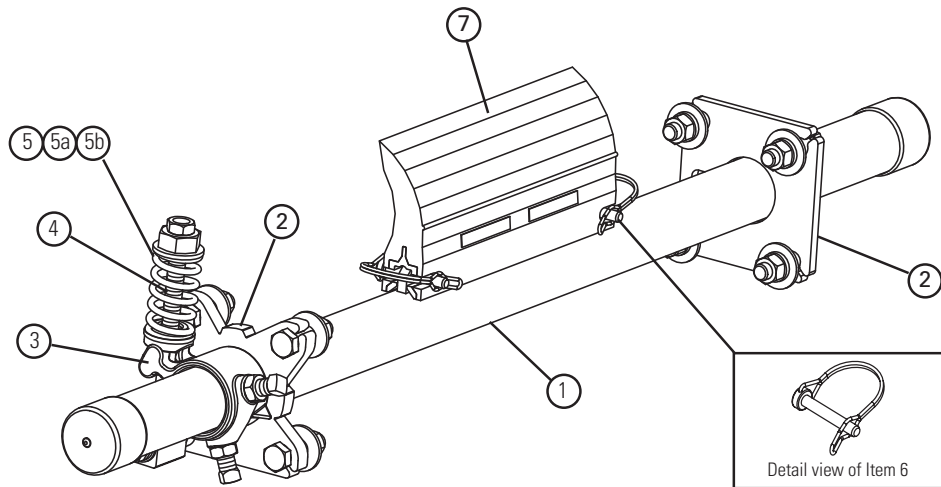

Replacement Parts

REF	DESCRIPTION	ORDERING NUMBER	ITEM CODE	WT. KG.
1	300 mm SS Pole	LSP12-S/S	77079	6.0
	450 mm SS Pole	LSP18-S/S	77080	7.0
	600 mm SS Pole	LSP24-S/S	77081	8.0
	750 mm SS Pole	LSP30-S/S	77082	9.0
	900 mm SS Pole	LSP36-S/S	77083	10.0
	1050 mm SS Pole	LSP42-S/S	77084	11.0
	1200 mm SS Pole	LSP48-S/S	77085	12.0
	1350 mm SS Pole	LSP54-S/S	77086	13.0
	1500 mm SS Pole	LSP60-S/S	77087	14.1
2	SS Mounting Plate Kit (10"-46"/250-1150mm)* (incl. 1 tensioner mounting plate and 1 pole mounting plate)	LSTMPK-S/S	78933	1.6
2a	SS Mounting Plate Kit (52"+/1300mm+)* (incl. 2 tensioner mounting plates)	LSTMPK2-S/S	78462	3.3
3	Torque Arm Kit* (1 ea.)	LST-TAK	77120	0.6
4	Pivot Block/Rod Kit* (1 ea.)	LSTPB-RK	77367	0.4
5	Tension Spring - Black (1 ea.) for blades 10'-28" (250-700mm)	CTS-B-S/S	78387	0.1
5a	Tension Spring - White (1 ea.) for blades 34" - 70" (850 - 1750mm)	LS-SW-S/S	78850	0.1
5b	Tension Spring - Silver (1 ea.) for blades 1300 - 1450 mm)	LS-SS	77118	0.1
6	SS LS Blade Pin (1 ea.)	LS-BP-S/S	77115	0.05
-	SS LST Spring Tensioner* - Black incl. 1 ea. items 2 & 3 for blades 10'-28" (250 - 700mm)	LST-B-S/S	77124	3.4
-	SS LST Spring Tensioner* - White incl. 1 ea. items 2 & 3a for blades 34"- 46" (850 - 1150mm)	LST-W-S/S	77125	3.5
-	SS LST Spring Tensioner* - White (dual) incl. 1 ea. item 2a and 2 ea. item 3a for blades 52"- 70" (1300 - 1750mm)	LST-W-S/S-2	77126	6.9

Hardware Included

 **Stock items** (non-shaded) refer to (*) for specific lead time, if not specified, standard lead time applies.

 **Non-stock items** (shaded) please contact Flexco for dispatch options and lead times.

U.S. Patent No. D482,508S; 9,242,805; D756,060; D747,838 (blade)

U.S. Patent No. 8,662,283 (tensioner)

Spring Tensioner Selection Chart

CLEANER BLADE WIDTH	77124 BLACK	77125 WHITE	77126 WHITE (Dual)
ConShear-LS 250 - 700 mm	X		
ConShear-LS 850 - 1150 mm		X	
ConShear-LS 1300 - 1750 mm			X

For best results use Flexco® Genuine Replacement Blades and Parts.

Replacement Parts List

EZP-LS *Limited Space Primary Cleaner and Stainless Steel Limited Space Primary Cleaner*

Ordering Information ConShear™-LS Replacement Blades

BELT WIDTH mm	BLADE WIDTH mm	ORDERING NUMBER	ITEM CODE	WT. KG.
300	250	CRB-LS10	77088	1.0
450	400	CRB-LS16	77089	1.5
600	550	CRB-LS22	77090	2.1
750	700	CRB-LS28	77091	2.6
900	850	CRB-LS34	77092	3.2
1050	1000	CRB-LS40	77093	3.8
1200	1150	CRB-LS46	77094	4.4
1350	1300	CRB-LS52	77095	4.9
1500	1450	CRB-LS58	77096	5.5

Other blade sizes available upon request.

Ordering Information ConShear™-LS High-Temp Replacement Blades

BLADE WIDTH mm	ORDERING NUMBER	ITEM CODE	WT. LBS.
400	CRB-LS16HT	77552	1.5
550	CRB-LS22HT	77553	2.1
700	CRB-LS28HT	77554	2.6
850	CRB-LS34HT	77555	3.2
1000	CRB-LS40HT	77556	3.8
1150	CRB-LS46HT	77557	4.4
1300	CRB-LS52HT	77558	4.9
1450	CRB-LS58HT	77559	5.5

Other blade sizes available upon request.

Ordering Information White ConShear™-LS Replacement Blades (Chemical Resistant/Food Grade) ‡

BLADE WIDTH mm	ORDERING NUMBER	ITEM CODE	WT. KG.
250	CRB-LS10W	77097	1.0
400	CRB-LS16W	77098	1.5
550	CRB-LS22W	77099	2.1
700	CRB-LS28W	77100	2.6
850	CRB-LS34W	77101	3.2
1000	CRB-LS40W	77102	3.8
1150	CRB-LS46W	77103	4.4
1300	CRB-LS52W	77104	4.9
1450	CRB-LS58W	77105	5.5

‡ All ingredients used in the urethane formulation of this blade comply with the relevant requirements of 21 CFR (FDA Code of Federal Regulations) for use in repeated bulk dry food applications

Stock items (non-shaded) refer to (*) for specific lead time, if not specified, standard lead time applies.

Non-stock items (shaded) please contact Flexco for dispatch options and lead times.

U.S. Patent No. D482,508S; 9,242,805; D756,060; D747,838

Product Ordering Information

EZP1 Standard Duty Primary Cleaner and EZP1 Stainless Steel Primary Cleaner



Ordering Information EZP1 Primary Cleaner Belt Width Minus 50mm

BELT WIDTH mm	BLADE COVERAGE mm	ORDERING NUMBER	ITEM CODE	WT. KG.
450	400	EZP1-218	75611	25.1
600	550	EZP1-224	75612	27.8
750	700	EZP1-230	75613	30.5
900	850	EZP1-236	75614	33.2
1050	1000	EZP1-242	75615	35.9
1200	1150	EZP1-248	75616	38.6
1350	1300	EZP1-254	75617	41.2
1500	1450	EZP1-260	75618	43.9
1800	1750	EZP1-272	75771	46.6

Ordering Information EZP1 Primary Cleaner Stainless Steel

BELT WIDTH mm	BLADE COVERAGE mm	ORDERING NUMBER	ITEM CODE	WT. KG.
450	400	EZP1-218-S/S	61081	25.7
600	550	EZP1-224-S/S	61082	28.4
750	700	EZP1-230-S/S	61017	31.1
900	850	EZP1-236-S/S	61083	33.9
1050	1000	EZP1-242-S/S	61016	36.6
1200	1150	EZP1-248-S/S	61084	39.3
1350	1300	EZP1-254-S/S	61085	42
1500	1450	EZP1-260-S/S	61086	44.8
1800	1750	EZP1-272-S/S	61087	47.5

Other blade sizes available upon request.

Ordering Information EZP1 High Temp Primary Cleaner Belt Width Minus 50mm

BELT WIDTH mm	BLADE COVERAGE mm	ORDERING NUMBER	ITEM CODE	WT. KG.
300	250	HTF212	76658	22
450	400	HTF218	76659	25.1
600	550	HTF224	76660	27.8
750	700	HTF230	76661	30.5
900	850	HTF236	76662	33.2
1050	1000	HTF242	76663	35.9
1200	1150	HTF248	76664	38.6
1350	1300	HTF254	76665	41.2
1500	1450	HTF260	76666	43.9
1800	1750	HTF272	76667	46.6

Ordering Information EZP1 Primary Cleaner Stainless Steel High Temp Belt Width Minus 50mm

BELT WIDTH mm	BLADE COVERAGE mm	ORDERING NUMBER	ITEM CODE	WT. KG.
300	250	HTF212-S/S	62826	22.0
450	400	HTF218-S/S	62827	25.1
600	550	HTF224-S/S	62828	27.8
750	700	HTF230-S/S	62829	30.5
900	850	HTF236-S/S	62830	33.2
1050	1000	HTF242-S/S	62831	35.9
1200	1150	HTF248-S/S	62832	38.6
1350	1300	HTF254-S/S	62833	41.2
1500	1450	HTF260-S/S	62834	43.9
1800	1750	HTF272-S/S	62835	46.6

Ordering Information EZP1 Stainless Steel Primary Cleaner with White ConShear Blade Belt Width Minus 50mm

BELT WIDTH mm	BLADE COVERAGE mm	ORDERING NUMBER	ITEM CODE	WT. KG.
300	250	CFG-212	78838	22.5
450	400	CFG-218	78839	25.1
600	550	CFG-224	78840	27.8
750	700	CFG-230	78841	30.5
900	850	CFG-236	78842	33.2
1050	1000	CFG-242	78843	35.9
1200	1150	CFG-248	78844	38.5
1350	1300	CFG-254	78845	41.2
1500	1450	CFG-260	78846	43.9
1800	1750	CFG-272	78847	46.6

Ordering Information EZP1 Primary Stainless Steel Ultra High-Temp Belt Width Minus 50mm

BELT WIDTH		BLADE WIDTH		ORDERING NUMBER	ITEM CODE	WT. KG.
mm	in.	mm	in.			
450	18	400	16	EZP1-UHT2-450-S/S	66956	25.1
600	24	550	22	EZP1-UHT2-600-S/S	66957	27.8
750	30	700	28	EZP1-UHT2-750-S/S	66958	30.4
900	36	850	34	EZP1-UHT2-900-S/S	66959	33.1
1050	42	1000	40	EZP1-UHT2-1050-S/S	66960	35.8
1200	48	1150	46	EZP1-UHT2-1200-S/S	66961	38.5
1350	54	1300	52	EZP1-UHT2-1350-S/S	66962	41.1
1500	60	1450	58	EZP1-UHT2-1500-S/S	66963	43.8
1800	72	1750	70	EZP1-UHT2-1800-S/S	66964	46.5

U.S. Patent No. D482,508S; 9,242,805; D756,060; D747,838

Specifications & Guidelines

EZP1 Standard Duty Primary Cleaner

Pole Length Specifications*

CLEANER SIZE mm	POLE LENGTH mm	MAXIMUM CONVEYOR SPAN mm
300	1050	925
450	1200	1075
600	1350	1225
750	1500	1375
900	1650	1525
1050	1800	1675
1200	1950	1825
1350	2200	2075
1500	2350	2225
1800	2650	2525

Pole Diameter - 60mm

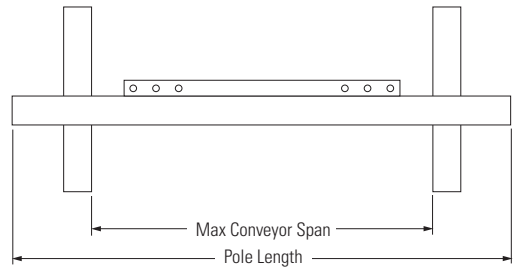

Clearance Guidelines for Installation

HORIZONTAL CLEARANCE REQUIRED mm	VERTICAL CLEARANCE REQUIRED mm
100	238

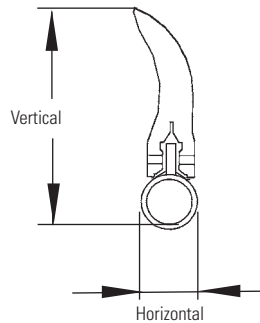

Pole Location Specs

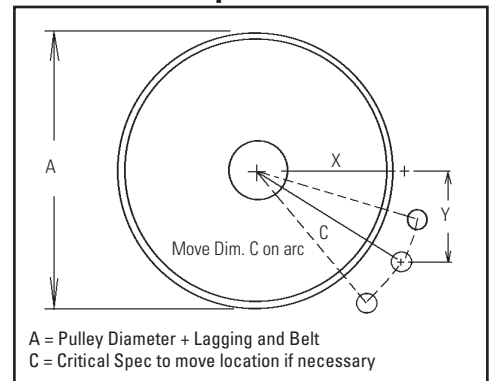

Spring Length Chart

with EST Spring Tensioner

BLADE WIDTH		PURPLE SPRING		SILVER SPRING		BLACK SPRING	
mm	in.	mm	in.	mm	in.	mm	in.
250	10	146	5 3/4	159	6 1/4	N/A	N/A
400	16	133	5 1/4	152	6	N/A	N/A
550	22	121	4 3/4	149	5 7/8	N/A	N/A
700	28	108	4 1/4	143	5 5/8	N/A	N/A
850	34	N/A	N/A	137	5 3/8	143	5 5/8
1000	40	N/A	N/A	130	5 1/8	140	5 1/2
1150	46	N/A	N/A	127	5	133	5 1/4
1300	52	N/A	N/A	121	4 3/4	130	5 1/8
1450	58	N/A	N/A	N/A	N/A	127	5
1600	64	N/A	N/A	N/A	N/A	121	4 3/4
1750	70	N/A	N/A	N/A	N/A	117	4 5/8

Shading indicates preferred spring option

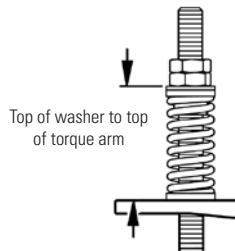

Pole Location Chart

A	X	Y	C
250	74	230	242
275	92	230	248
300	108	230	254
325	131	230	265
350	146	230	273
375	166	230	284
400	179	230	291
425	195	230	301
450	207	230	309
475	223	230	320
500	235	230	329
525	249	230	339
550	266	230	352
575	283	230	365
600	299	230	377
625	314	230	390
650	330	230	402
675	346	230	415
700	360	230	427
725	374	230	439
750	389	230	452
775	403	230	464
800	417	230	477
825	432	230	489
850	446	230	501
875	460	230	514
900	474	230	526

Specifications:

- Maximum Belt SpeedContact Flexco®
- Temperature Rating-35°C to 82°C
- Minimum Pulley Diameter.....250mm
- Usable Blade Wear Length.....100mm
- BladePolyurethane (proprietary blend for abrasion resistance and long wear)
- Available for Belt Widths300 to 1800 mm

U.S. Patent No. D482,508S; 9,242,805; D756,060; D747,838

Replacement Parts List

EZP1 Standard Duty Primary Cleaner

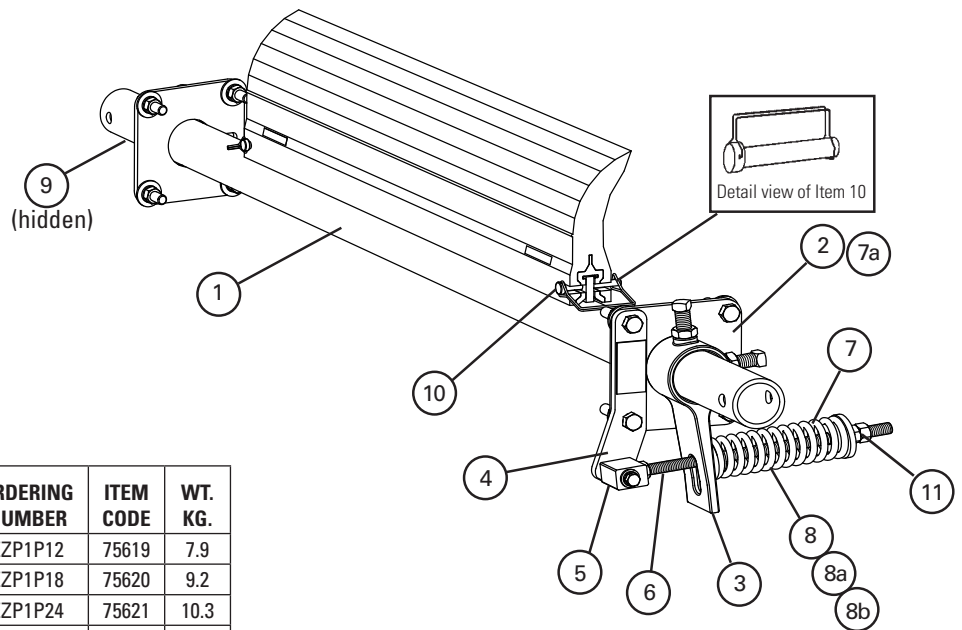

Replacement Parts

REF	DESCRIPTION	ORDERING NUMBER	ITEM CODE	WT. KG.
1	300 mm Pole	EZP1P12	75619	7.9
	450 mm Pole	EZP1P18	75620	9.2
	600 mm Pole	EZP1P24	75621	10.3
	750 mm Pole	EZP1P30	75622	12.1
	900 mm Pole	EZP1P36	75623	13.8
	1050 mm Pole	EZP1P42	75624	14.9
	1200 mm Pole	EZP1P48	75625	16.1
	1350 mm Pole	EZP1P54	75626	17.8
	1500 mm Pole	EZP1P60	75627	19.7
	1800 mm Pole	EZP1P72	75772	21.9
2	Mounting Plate Kit* (2 ea.)	EZP1MPK	75637	3.5
3	Torque Arm Kit* (1 ea.)	ESTAK	76406	1.6
4	Pivot Shaft Bracket Kit* (1 ea.)	ESPSBK	76407	0.8
5	Pivot Block Kit*	ESPBK	76408	0.3
6	Pivot Rod Kit*	ESPRK	76409	0.6
7	Bushing Kit - Purple and Silver (includes 2 bushings)	ESBK-PS	76410	0.1
7a	Bushing Kit - Black (includes 2 bushings)	ESBK-B	76411	0.1
8	Tension Spring - Purple	QMTS-P	75845	0.5
8a	Tension Spring - Silver	ESS-S	76412	0.6
8b	Tension Spring - Black	ESS-B	76413	0.6
9	Pole Lock* (1 ea.)	EZP1PL	75641	0.5
-	EST Tensioner - Purple* for blade widths 300 - 700 mm (includes 1 each items 3, 4, 5, 6, 7 & 8)	EST-P	76403	3.5
-	EST Tensioner - Silver* for blade widths 850 - 1300 mm (includes 1 each items 3, 4, 5, 6, 7 & 8a)	EST-S	76404	3.6
-	EST Tensioner - Black* for blade widths 1450 - 1750 mm (includes 1 each items 3, 4, 5, 6, 7a & 8b)	EST-B	76405	3.7
10	Blade Pin (1 ea.)	EZP1BP	75642	0.1

*Hardware Included

Spring Tensioner Selection Chart

CLEANER BLADE WIDTH	76403 EST-P	76404 EST-S	76405 EST-B
ConShear™ 300 - 700 mm	X		
ConShear 850 - 1300 mm		X	
ConShear 1450 - 1750 mm			X

Stock items (non-shaded) refer to (*) for specific lead time, if not specified, standard lead time applies.

Non-stock items (shaded) please contact Flexco for dispatch options and lead times.

U.S. Patent No. D482,508S; 9,242,805; D756,060; D747,838

Replacement Parts List

EZP1 Stainless Steel Primary Cleaner

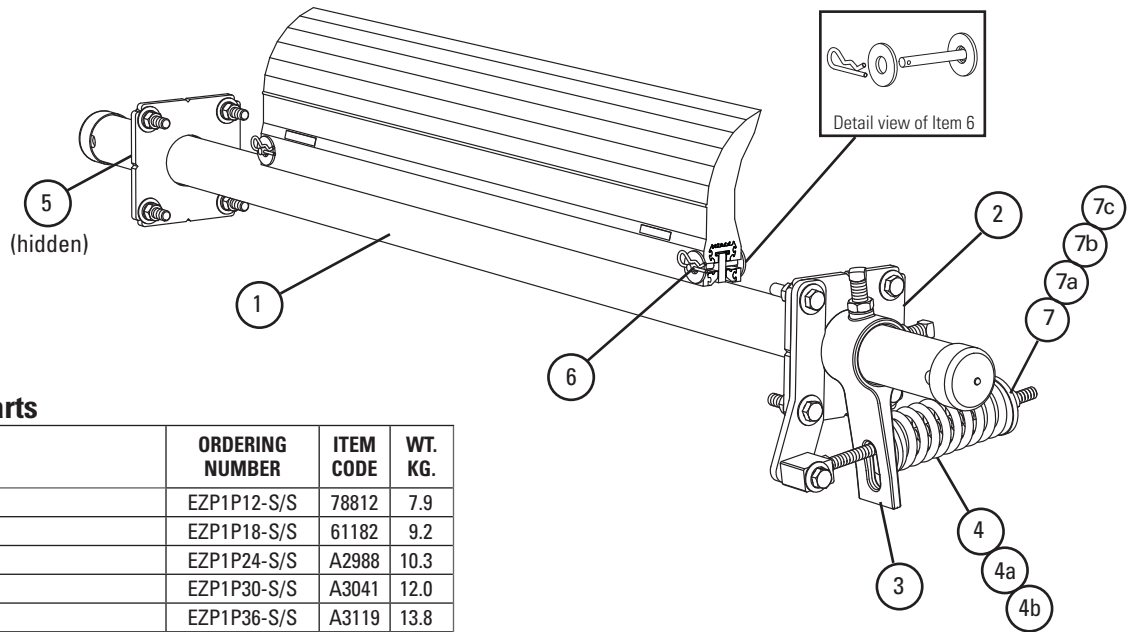

Replacement Parts

REF	DESCRIPTION	ORDERING NUMBER	ITEM CODE	WT. KG.
1	300 mm S/S Pole	EZP1P12-S/S	78812	7.9
	450 mm S/S Pole	EZP1P18-S/S	61182	9.2
	600 mm S/S Pole	EZP1P24-S/S	A2988	10.3
	750 mm S/S Pole	EZP1P30-S/S	A3041	12.0
	900 mm S/S Pole	EZP1P36-S/S	A3119	13.8
	1050 mm S/S Pole	EZP1P42-S/S	61183	14.9
	1200 mm S/S Pole	EZP1P48-S/S	61491	16.0
	1350 mm S/S Pole	EZP1P54-S/S	61184	17.8
	1500 mm S/S Pole	EZP1P60-S/S	61185	19.7
	1800 mm S/S Pole	EZP1P72-S/S	61186	21.9
2	SS Mounting Plate Kit* (2 ea.)	EZP1MPK-S/S	78923	3.5
3	SS Torque Arm Kit* (1 ea.)	ESTAK-EST-S/S	78849	1.6
4	SS Tension Spring - Purple	QMTS-P-S/S	77450	0.5
4a	SS Tension Spring - White	QMTS-W-S/S	77451	0.5
4b	SS Tension Spring - Gold	QMTS-G-S/S	77452	0.6
5	SS Pole Lock* (1 ea.)	EZP1PL-S/S	78848	0.5
6	Blade Pin (1 ea.)	MSPBPK-S/S	77583	0.05
7	Bushing Kit - Purple and Silver (includes 2 bushings)	ESBK-PS	76410	0.1
7a	Bushing Kit - Black (includes 2 bushings)	ESBK-B	76411	0.1
7b	EST Bushing Kit - UHT, Purple & White Spring (includes 2 bushings)	ESBK-ATEX	90264	0.05
7c	EST Bushing Kit - UHT, Gold Spring (includes 2 bushings)	ESBK-B EST	76411	0.05
-	SS EST Tensioner - Purple* for blade widths 300 - 700mm (12" - 28") (includes 1 each items 2, 3, 4)	EST-P-S/S	78808	3.5
-	SS EST Tensioner - White* for blade widths 850 - 1300mm (34" - 52") (includes 1 each items 2, 3, 4a)	EST-W-S/S	78809	3.6
-	SS EST Tensioner - Gold* for blade widths 1450 - 1750mm (58" - 70") (includes 1 each items 2, 3, 4b)	EST-G-S/S	78810	3.7
-	EST S/S UHT Tensioner - Purple* for blade widths 300 - 700mm (12" - 28") (includes items 2, 3, 4 and 7b)	EST-P-S/S-UHT	66993	4.0
-	EST S/S UHT Tensioner - White* for blade widths 850 - 1300mm (34" - 52") (includes items 2, 3, 4a and 7b)	EST-W-S/S-UHT	66994	4.1
-	EST S/S UHT Tensioner - Gold* for blade widths 1450 - 1750mm (58" - 70") (includes items 2, 3, 4b and 7c)	EST-G-S/S-UHT	66995	4.2

*Hardware Included

Stainless Steel Spring Tensioner Selection Chart

CLEANER BLADE WIDTH	78808 EST-P-S/S	78809 EST-W-S/S	78810 EST-G-S/S
ConShear™ 300 - 700 mm	X		
ConShear 850 - 1300 mm		X	
ConShear 1450 - 1750 mm			X

Stock items (non-shaded) refer to (*) for specific lead time, if not specified, standard lead time applies.

Non-stock items (shaded) please contact Flexco for dispatch options and lead times.

U.S. Patent No. D482,508S; 9,242,805; D756,060; D747,838

Replacement Parts List

EZP1 Standard Duty Primary Cleaner and EZP1 Stainless Steel Primary Cleaner

Ordering Information ConShear™ Replacement Blades

BELT WIDTH mm	BLADE COVERAGE mm	ORDERING NUMBER	ITEM CODE	WT. KG.
450	400	CRB16	75629	3.3
600	550	CRB22	75630	4.6
750	700	CRB28	75631	5.8
900	850	CRB34	75632	7.1
1050	1000	CRB40	75633	8.0
1200	1150	CRB46	75634	9.6
1350	1300	CRB52	75635	10.8
1500	1450	CRB58	75636	12.1
1650	1600	CRB64	75775	13.3
1800	1750	CRB70	75773	14.6

Other blade sizes available upon request.

Ordering Information ConShear High Temp Replacement Blades

BELT WIDTH mm	BLADE COVERAGE mm	ORDERING NUMBER	ITEM CODE	WT. KG.
300	250	CRB-HT10	76593	2.2
450	400	CRB-HT16	76594	3.5
600	550	CRB-HT22	76595	4.7
750	700	CRB-HT28	76596	6
900	850	CRB-HT34	76597	7.4
1050	1000	CRB-HT40	76598	8.7
1200	1150	CRB-HT46	76599	13
1350	1300	CRB-HT52	76600	11.3
1500	1450	CRB-HT58	76601	12.6
1650	1600	CRB-HT64	76602	13.9
1800	1750	CRB-HT70	76603	15.2

Ordering Information White ConShear™ Replacement Blades (Chemical Resistant/Food Grade) ‡

BELT WIDTH mm	BLADE COVERAGE mm	ORDERING NUMBER	ITEM CODE	WT. KG.
450	400	CRB-W16	78472	3.3
600	550	CRB-W22	78473	4.6
750	700	CRB-W28	78474	5.8
900	850	CRB-W34	78475	7.1
1050	1000	CRB-W40	78476	8.0
1200	1150	CRB-W46	78477	9.6
1350	1300	CRB-W52	78478	10.8
1500	1450	CRB-W58	78479	12.1
1650	1600	CRB-W64	78480	13.3
1800	1750	CRB-W70	78481	14.6

‡ All ingredients used in the urethane formulation of this blade comply with the relevant requirements of 21 CFR (FDA Code of Federal Regulations) for use in repeated bulk dry food applications

Ordering Information Ultra High-Temp ConShear™ Replacement Blades

BELT WIDTH mm	BLADE COVERAGE mm	ORDERING NUMBER	ITEM CODE	WT. KG.
450	400	CRB-UHT-400	91254	3.3
600	550	CRB-UHT-550	91255	4.6
750	700	CRB-UHT-700	91256	5.8
900	850	CRB-UHT-850	91257	7.0
1050	1000	CRB-UHT-1000	91258	8.3
1200	1150	CRB-UHT-1150	91259	9.5
1350	1300	CRB-UHT-1300	91260	10.8
1500	1450	CRB-UHT-1450	91261	12.0
1800	1750	CRB-UHT-1750	91263	14.5

Stock items (non-shaded) refer to (*) for specific lead time, if not specified, standard lead time applies.

Non-stock items (shaded) please contact Flexco for dispatch options and lead times.

U.S. Patent No. D482,508S; 9,242,805; D756,060; D747,838

Product Ordering Information

EZP1T Twist Tensioner Primary Cleaner

EZP1T Primary Cleaner with Twist Tensioner Belt Width Minus 2" (50mm)



BELT WIDTH		BLADE WIDTH		ORDERING NUMBER	ITEM CODE	WT. KG.
in.	mm	in.	mm			
12	300	10	250	EZP1T-212	78488	38.5
18	450	16	400	EZP1T-218	78489	44.5
24	600	22	550	EZP1T-224	78490	50.5
30	750	28	700	EZP1T-230	78491	56.5
36	900	34	850	EZP1T-236	78492	62.5
42	1050	40	1000	EZP1T-242	78493	68.4
48	1200	46	1150	EZP1T-248	78494	74.4
54	1350	52	1300	EZP1T-254	78495	83.7
60	1500	58	1450	EZP1T-260	78496	92.0
72	1800	70	1750	EZP1T-272	78497	101.6

Product Notes:

- For optimal cleaning and reduced blade retensioning maintenance, the cleaner blade width should be sized to fit the material path of the belt. The material path is typically 2/3 of the belt width. In most cases a blade size of belt width minus 200mm may be the best selection.
- Each cleaner can be retrofitted with three replacement blade sizes (belt width minus 50mm, minus 200mm, or minus 350mm).
- Comes complete with universal mounting plates and tensioner.
- Visual tension check. No guesswork on blade tensioning. Simply measure the spring, check label on tensioner and turn adjusting nut to restore optimal tension.
- Works with mechanical splices. Polyurethane blade glides over splices.
- Compatible with reversing belts.
- For applications requiring longer pole lengths, go to the minus 200mm chart and select the cleaner one belt width size larger. This will provide a pole 150mm longer and a blade size of belt width minus 50mm.

Stock items (non-shaded) refer to (*) for specific lead time, if not specified, standard lead time applies.

Non-stock items (shaded) please contact Flexco for dispatch options and lead times.

U.S. Patent No. D482,508S; 9,242,805; D756,060; D747,838

Replacement Parts List

EZP1T Twist Tensioner Primary Cleaner

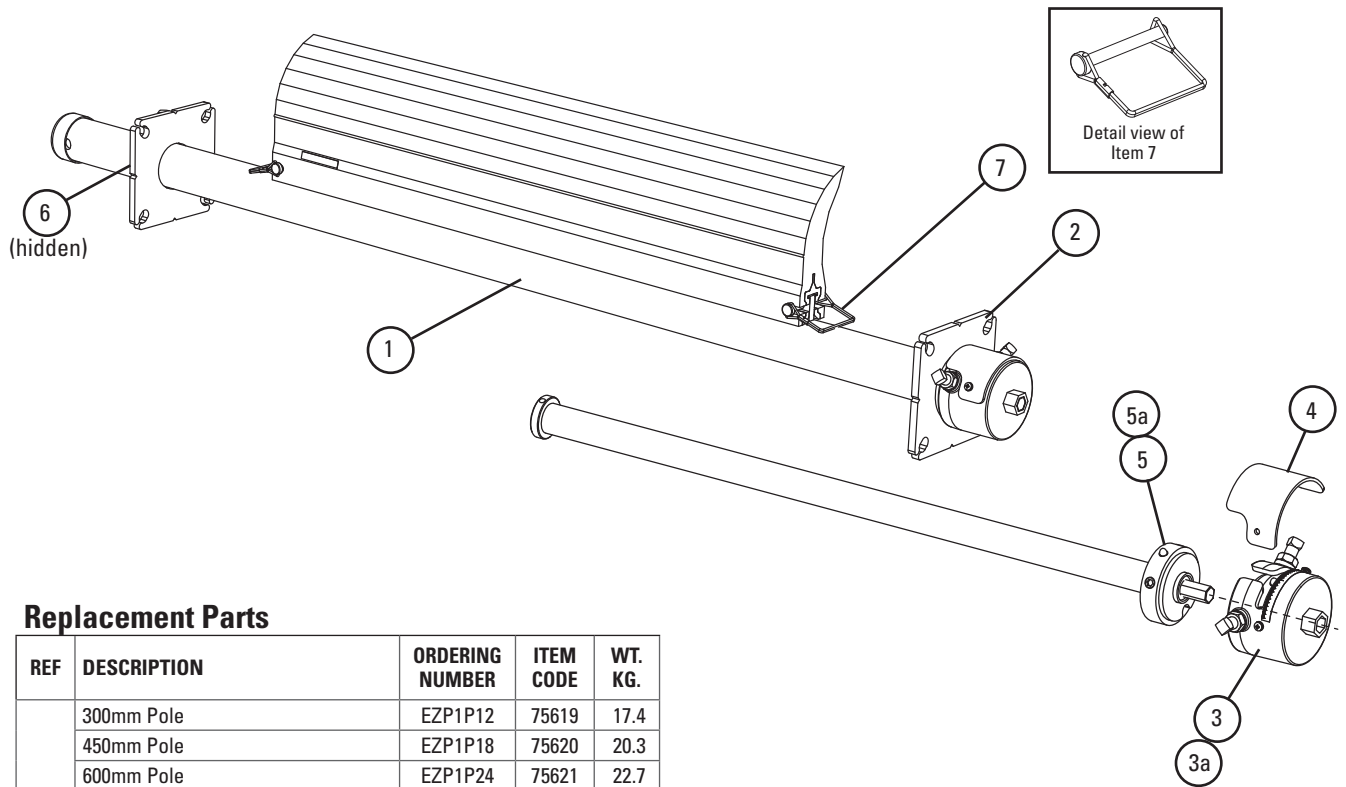

Replacement Parts

REF	DESCRIPTION	ORDERING NUMBER	ITEM CODE	WT. KG.
1	300mm Pole	EZP1P12	75619	17.4
	450mm Pole	EZP1P18	75620	20.3
	600mm Pole	EZP1P24	75621	22.7
	750mm Pole	EZP1P30	75622	26.5
	900mm Pole	EZP1P36	75623	30.4
	1050mm Pole	EZP1P42	75624	32.7
	1200mm Pole	EZP1P48	75625	35.3
	1350mm Pole	EZP1P54	75626	39.2
	1500mm Pole	EZP1P60	75627	43.3
	1800mm Pole	EZP1P72	75772	48.2
2	Torsion Mounting Plate Kit* (2 ea.)	EZPTMPK	78507	8.7
3	Torsion Cap Kit* (1 ea.) (includes 1 ea. Item 4)	EZPTCK	78508	3.2
3a	Torsion Cap Kit HD* (1 ea.) (includes 1 ea. Item 4)	EZPTCKHD	78509	3.2
4	Torsion Shield	EZPTSR	78510	.1
5	Torsion Spring Kit	EZPTSK	78511	6.0
5a	Torsion Spring Kit HD	EZPTSKHD	78512	8.5
6	Pole Lock* (1 ea.)	EZP1PL	75641	1.1
-	Torsion Bar Tensioner for blade widths 300 - 1200mm (includes 1 each items 3, 4, & 5)	EZPTBT	77384	17.4
-	Torsion Bar Tensioner HD for blade widths 1350 - 1800mm (includes 1 each items 3a, 4, & 5a)	EZPTBTHD	77385	20.0
7	Blade Pin (1 ea.)	EZP1BP	75642	0.1

*Hardware Included

Torsion Bar Tensioner Selection Chart

CLEANER BLADE WIDTH	77384 EZPTBT	77385 EZPTBTHD
ConShear 300 - 1200mm	X	
ConShear 1350 - 1800mm		X

Stock items (non-shaded) refer to (*) for specific lead time, if not specified, standard lead time applies.

Non-stock items (shaded) please contact Flexco for dispatch options and lead times.

U.S. Patent No. D482,508S; 9,242,805; D756,060; D747,838

Product Ordering Information

Spring Covers and Tensioner Lock

Spring Covers

ORDERING NUMBER	ITEM CODE	WT. KG.
SPG-CVR-A	77387	0.14
SPG-CVR-B	77388	0.14
SPG-CVR-C	77389	0.14
SPG-CVR-D	77390	0.18
SPG-CVR-E	77391	0.18
SPG-CVR-F	77392	0.14
SPG-CVR-G	77393	0.14
SPG-CVR-H	77741	0.14

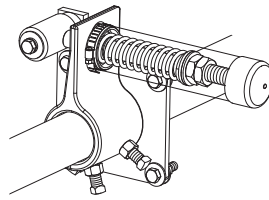
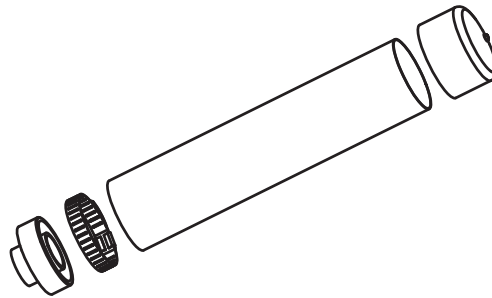

Spring cover on Primary Cleaner tensioner

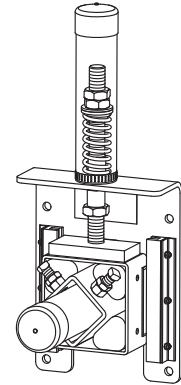

Spring cover on Secondary cleaner tensioner

Tensioner Lock

Designed to prevent tampering or unauthorized retensioning of the cleaner.

ORDERING NUMBER	ITEM CODE	WT. KG.
TEN-LOCK-KIT	77443	0.18

*For MSP, MMP, MHP, MHCP, H-Type® Primary Cleaner and MSS, MHS, MDWS Secondary Cleaners

Includes 1 tensioner lock
Lead time: 1 working day

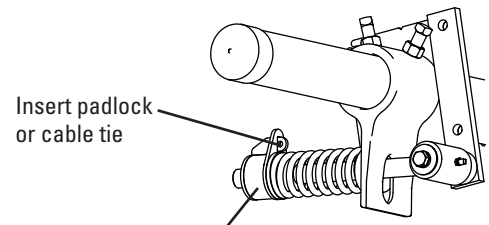
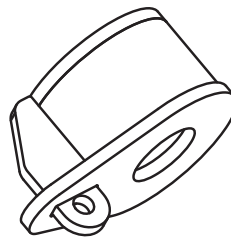

Tensioner Lock

(Primary Cleaner tensioner shown)

 **Stock items** (non-shaded) refer to (*) for specific lead time, if not specified, standard lead time applies.

 **Non-stock items** (shaded) please contact Flexco for dispatch options and lead times.

U.S. Patent No. D664,829

Product Ordering Information

MMP Medium Mine-Duty Primary Cleaner

MMP Medium-Duty Primary Cleaner Belt Width Minus 150mm Blade

BELT WIDTH mm	BLADE COVERAGE mm	ORDERING NUMBER	ITEM CODE	WT. KG.
600	450	MMP-624	76450	72.4
750	600	MMP-630	76451	79.6
900	750	MMP-636	76452	86.6
1050	900	MMP-642	76453	93.7
1200	1050	MMP-648	76454	100.8
1350	1200	MMP-654	76455	107.9
1500	1350	MMP-660	76456	115.0
1800	1650	MMP-672	76457	132.3
2100	1950	MMP-684	76798	156.4



Blade Width Selection

BELT WIDTH mm	ITEM CODE		
	BELT WIDTH MINUS 150 mm	BELT WIDTH MINUS 300 mm	BELT WIDTH MINUS 450 mm
600	76485	N/A	N/A
750	76486	76485	N/A
900	76487	76486	76485
1050	76488	76487	76486
1200	76489	76488	76487
1350	76490	76489	76488
1500	76491	76490	76489
1800	76493	76492	76491
2100	76697	76494	76493
2400	77048	77047	76697



TuffShear™
Replacement Blades

Ordering Information TuffShear™ Replacement Blades

BLADE WIDTH mm	ORDERING NUMBER	ITEM CODE	WT. KG.
450	TRB18	76485	9.6
600	TRB24	76486	12.7
750	TRB30	76487	15.9
900	TRB36	76488	19.1
1050	TRB42	76489	22.3
1200	TRB48	76490	25.5
1350	TRB54	76491	28.6
1500	TRB60	76492	31.8
1650	TRB66	76493	35.0
1800	TRB72	76494	38.2
1950	TRB78	76697	41.4

Other blade sizes available upon request.

Product Notes:

- Recommended for medium-duty conveyor applications. For abusive applications see the MHP Heavy-Duty Primary Cleaner or the MHCP Heavy-Duty Cartridge Primary Cleaner.
- Pole Length: Belt width plus 1350 mm. For longer requirements see Installation Accessories - Pole Extender Kit.
- Visual Tension Check: No guesswork on blade tensioning. Measure the spring and adjust to specified length per blade width to restore optimal tensioning.

Stock items (non-shaded) refer to (*) for specific lead time, if not specified, standard lead time applies.

Non-stock items (shaded) please contact Flexco for dispatch options and lead times.

U.S. Patent No. D482,508S

Product Ordering Information

Stainless Steel MMP Medium Mine-Duty Primary Cleaner

Stainless Steel MMP Medium-Duty Primary Cleaner Belt Width Minus 150mm Blade

BELT WIDTH mm	BLADE WIDTH mm	ORDERING NUMBER	ITEM CODE
600	450	MMP-624-S/S	77424
750	600	MMP-630-S/S	77425
900	750	MMP-636-S/S	77426
1050	900	MMP-642-S/S	77427
1200	1050	MMP-648-S/S	77428
1350	1200	MMP-654-S/S	77429
1500	1350	MMP-660-S/S	77430
1800	1650	MMP-672-S/S	77431
2100	1950	MMP-684-S/S	77432

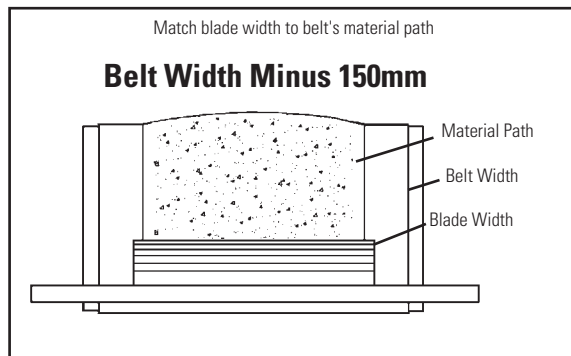

Product Notes:

- Recommended for medium-duty conveyor applications, but in corrosive environments.
- Material Path Option: Fit the blade width to the belt's material path. The material path is typically the center 2/3 of the belt width. In most cases a blade size of belt width minus 152 mm may be the best solution.
- Each cleaner pole is retrofittable for three blade sizes (belt width minus 152 mm, minus 305 mm or minus 457 mm).
- Pole Length: Belt width plus 1372 mm. For longer requirements see Installation Accessories - Pole Extender Kit.
- Visual Tension Check: No guesswork on blade tensioning. Measure the spring and adjust to specified length per blade width to restore optimal tensioning.
- To make cleaner installation easier and quicker, see Optional Mounting Kits.

 **Stock items** (non-shaded) refer to (*) for specific lead time, if not specified, standard lead time applies.

 **Non-stock items** (shaded) please contact Flexco for dispatch options and lead times.

U.S. Patent No. D482,508S

Replacement Parts List

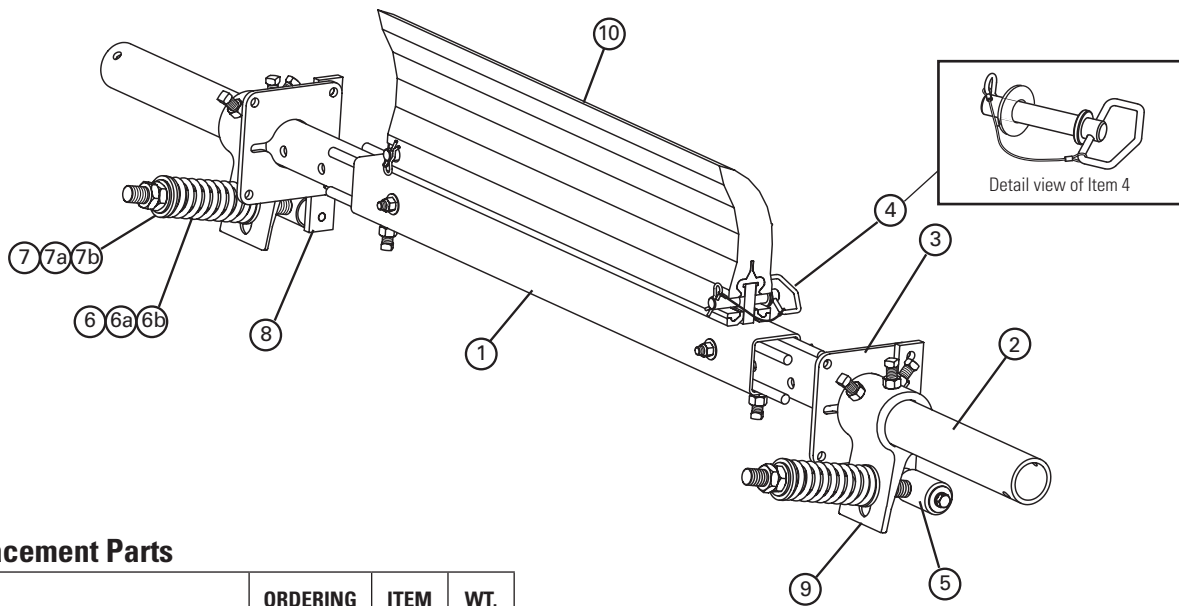

Replacement Parts

REF	DESCRIPTION	ORDERING NUMBER	ITEM CODE	WT. KG.
1	600 mm Pole	MMPCP24	76458	15.6
	750 mm Pole	MMPCP30	76459	19.6
	900 mm Pole	MMPCP36	76460	23.5
	1050 mm Pole	MMPCP42	76461	27.3
	1200 mm Pole	MMPCP48	76462	31.2
	1350 mm Pole	MMPCP54	76463	35.1
	1500 mm Pole	MMPCP60	76464	39.1
	1800 mm Pole	MMPCP72	76465	46.9
	2100 mm Pole	MMPCP84	76808	54.7
2	Extender Pole Kit (2 ea.)	MHP-EP	76392	24.6
3	Mounting Plate Kit* (2 ea.)	MSPMPK	75811	3.8
4	Blade Pin Kit* (1 ea.)	MMPBPK	76466	0.4
5	Pivot Arm Kit* (1 ea.)	QMTPAK	76096	2.0
6	Tension Spring - Purple (1 ea.) for blades 600 mm	QMTS-P	75845	0.3
6a	Tension Spring - White (1 ea.) for blades 750 - 1200 mm	PSTS-W	75898	0.8
6b	Tension Spring - Gold (1 ea.) for blades 1350 - 1950 mm	QMTS-G	76484	1.1
7	Bushing Kit - Purple (2 ea.)	QMTBK-P	76097	0.1
7a	Bushing Kit - White (2 ea.)	QMTBK-W	76098	0.1
7b	Bushing Kit - Gold (2 ea.)	QMTBK-G	76540	0.1
8	Pivot Shaft Bracket Kit* (1 ea.)	QMTPSBK	76099	2.0
9	Torsion Arm Kit* (1 ea.)	PSTA	75896	5.2
-	QMT Spring Tensioner* - Purple (incl. 1 ea. Items 5, 6, 7, 8, & 9) for blades 450 - 600 mm	QMT-P	76074	9.3
-	QMT Spring Tensioner* - White (incl. 1 ea. Items 5, 6a, 7a, 8, & 9) for blades 750 - 1200 mm	QMT-W	76075	10.0
-	QMT Spring Tensioner* - Gold (incl. 1 ea. Items 5, 6b, 7b, 8, & 9) for blades 1350 - 1950 mm	QMT-G	76483	10.6

*Hardware Included

Replacement TuffShear™ Blades

REF	BLADE WIDTH mm	ORDERING NUMBER	ITEM CODE	WT. KG.
10	450	TRB18	76485	9.6
	600	TRB24	76486	12.7
	750	TRB30	76487	16.0
	900	TRB36	76488	19.1
	1050	TRB42	76489	22.3
	1200	TRB48	76490	25.5
	1350	TRB54	76491	28.6
	1500	TRB60	76492	31.8
	1650	TRB66	76493	35.0
	1800	TRB72	76494	38.2
	1950	TRB78	76697	41.4
	2100	TRB84	77047	44.5
	2400	TRB90	77048	47.6

Order blade width for your belt width's material path:
Belt Width Minus 152 mm, Belt Width Minus 305 mm, or Belt Width Minus 457 mm.

Spring Tensioner Selection Chart

CLEANER BLADE WIDTH	76403 EST-P	76404 EST-S	76405 EST-B
TuffShear 450 - 600 mm	X		
TuffShear 750 - 1200 mm		X	
TuffShear 1350 - 1950 mm			X

Stock items (non-shaded) refer to (*) for specific lead time, if not specified, standard lead time applies.

Non-stock items (shaded) please contact Flexco for dispatch options and lead times.

U.S. Patent No. D482,508S

Replacement Parts List

MMP
Medium Mine-Duty Primary Cleaner

Air/Water Tensioner Replacement Parts

REF	DESCRIPTION	ORDERING NUMBER	ITEM CODE	WT. KG.
12	Air/Water Bag (1 ea.)	AWTB	75905	1.7
13	Mounting Base (1 ea.)	AWTMB	75906	10.4
14	Torque Arm* (1 ea.)	AWTA	75907	5.3
15	Hose Kit (15 M of hose and 6 hose clamps)	AWTHK	75909	3.1
16	Control Box (Complete)	AWTCB	75908	0.5
-	AWT Air/Water Tensioner (includes 2 each items 12, 13, & 14 and 1 each items 15 & 16)	AWT	75904	39.2
-	AWT Air/Water Tensioner w/o Control Box (includes 2 each items 12, 13, 14 & 1 each item 15)	AWTNCB	76069	34.2
-	AWT Air/Water Tensioner w/o Control Box, 1 side (includes 1 each items 12, 13, 14 & 15)	AWT-1S	76375	17.1

*Hardware Included

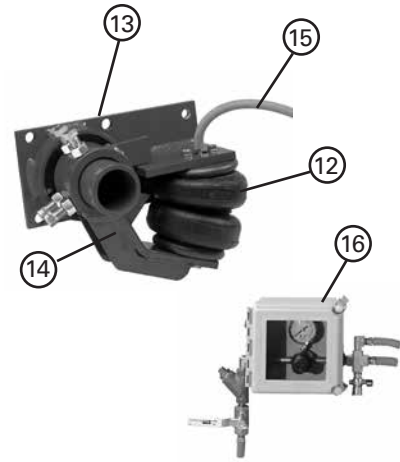

Stock items (non-shaded) refer to (*) for specific lead time, if not specified, standard lead time applies.

Non-stock items (shaded) please contact Flexco for dispatch options and lead times.

Replacement Parts List

Stainless Steel MMP Medium Mine-Duty Primary Cleaner

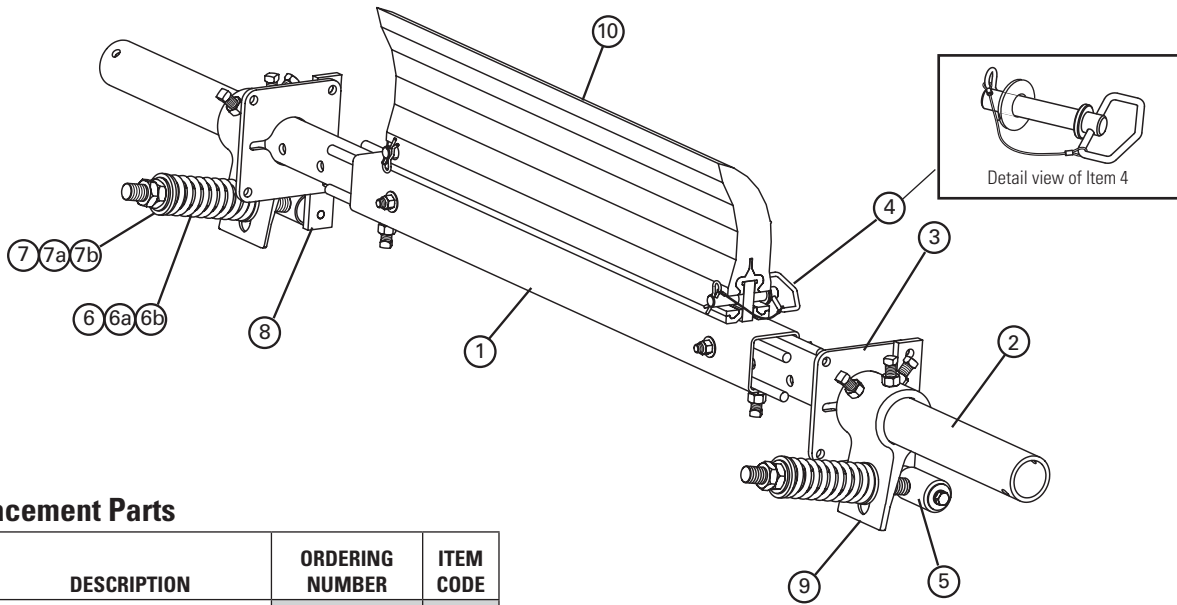

Replacement Parts

REF	DESCRIPTION	ORDERING NUMBER	ITEM CODE
1	600 mm SS Pole	MMPCP24-S/S	77590
	750 mm SS Pole	MMPCP30-S/S	77591
	900 mm SS Pole	MMPCP36-S/S	77592
	1050 mm SS Pole	MMPCP42-S/S	77593
	1200 mm SS Pole	MMPCP48-S/S	77594
	1350 mm SS Pole	MMPCP54-S/S	77595
	1500 mm SS Pole	MMPCP60-S/S	77596
	1800 mm SS Pole	MMPCP72-S/S	77597
	2100 mm SS Pole	MMPCP84-S/S	77598
2	SS Extender Pole Kit (2 ea.)	MHP-EP-S/S	77599
3	SS Mounting Plate Kit* (2 ea.)	MSPMPK-S/S	77582
4	SS Blade Pin Kit* (1 ea.)	MMPBPK-S/S	77600
5	SS Pivot Arm Kit* (1 ea.)	QMTPAK-S/S	77587
6	SS Tension Spring - Purple (1 ea.) for blades 600 mm	QMTS-P-S/S	77450
6a	SS Tension Spring - White (1 ea.) for blades 750 - 1200 mm	QSTS-W-S/S	77451
6b	SS Tension Spring - Gold (1 ea.) for blades 1350 - 1950 mm	QMTS-G-S/S	77452
7	Bushing Kit - Purple (2 ea.)	QMTBK-P	76097
7a	Bushing Kit - White (2 ea.)	QMTBK-W	76098
7b	Bushing Kit - Gold (2 ea.)	QMTBK-G	76540
8	SS Pivot Shaft Bracket Kit* (1 ea.)	QMTPSBK-S/S	77588
9	SS Torsion Arm Kit* (1 ea.)	PSTA-S/S	77442
-	SS QMT Spring Tensioner* - Purple (incl. 1 ea. Items 5, 6, 7, 8, & 9) for blades 450 - 600 mm	QMT-P-S/S	77584
-	SS QMT Spring Tensioner* - White (incl. 1 ea. Items 5, 6a, 7a, 8, & 9) for blades 750 - 1200 mm	QMT-W-S/S	77585
-	SS QMT Spring Tensioner* - Gold (incl. 1 ea. Items 5, 6b, 7b, 8, & 9) for blades 1350 - 1950 mm	QMT-G-S/S	77586

*Hardware Included

Replacement TuffShear™ Blades

REF	BLADE WIDTH mm	ORDERING NUMBER	ITEM CODE	WT. KG.
10	450	TRB18	76485	9.6
	600	TRB24	76486	12.7
	750	TRB30	76487	16.0
	900	TRB36	76488	19.1
	1050	TRB42	76489	22.3
	1200	TRB48	76490	25.5
	1350	TRB54	76491	28.6
	1500	TRB60	76492	31.8
	1650	TRB66	76493	35.0
	1800	TRB72	76494	38.2
	1950	TRB78	76697	41.4
	2100	TRB84	77047	44.5
	2400	TRB90	77048	47.6

Order blade width for your belt width's material path:
Belt Width Minus 152 mm, Belt Width Minus 305 mm, or
Belt Width Minus 457 mm.

Spring Tensioner Selection Chart

CLEANER BLADE WIDTH	76403 EST-P	76404 EST-S	76405 EST-B
TuffShear™ 450 - 600 mm	X		
TuffShear 750 - 1200 mm		X	
TuffShear 1350 - 1950 mm			X

Stock items (non-shaded) refer to (*) for specific lead time, if not specified, standard lead time applies.

Non-stock items (shaded) please contact Flexco for dispatch options and lead times.

U.S. Patent No. D482,508S

Specifications & Guidelines

MMP Medium Mine-Duty Primary Cleaner

Pole Length Specifications*

BELT WIDTH mm	MAX OVERALL POLE LENGTH mm	CENTRE POLE LENGTH mm	MAXIMUM CONVEYOR SPAN mm
600	1950	600	1650
750	2100	750	1800
900	2250	900	1950
1050	2400	1050	2100
1200	2550	1200	2250
1350	2700	1350	2400
1500	2850	1500	2550
1800	3150	1800	2850
2100	3450	2100	3150

* For special extra long pole length requirements a Pole Extender Kit (#76024) is available that provides 750 mm of extended pole length. Pole Diameter -73 mm

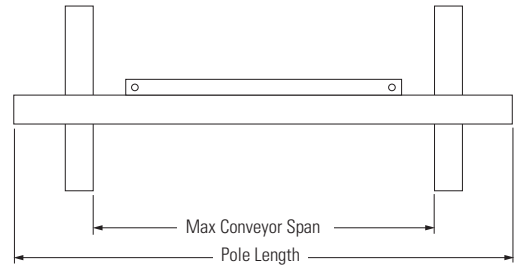

Pole Location Specs

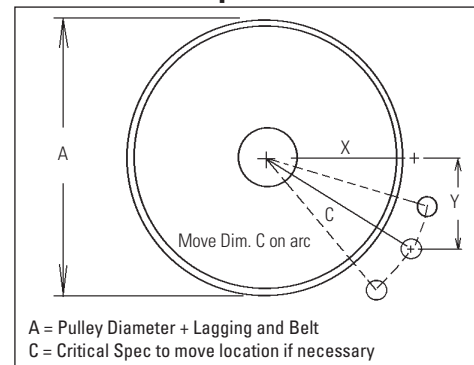

Clearance Guidelines for Installation

HORIZONTAL CLEARANCE REQUIRED mm	VERTICAL CLEARANCE REQUIRED mm
100	325

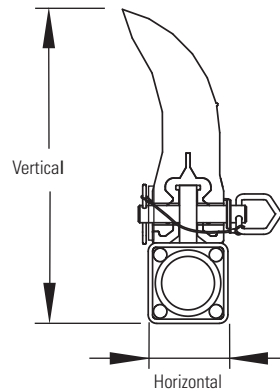

Spring Length Chart with QMT Spring Tensioner

BLADE WIDTH mm	PURPLE SPRINGS mm	WHITE SPRINGS mm	GOLD SPRINGS mm
450	110	150	160
600	100	140	150
750	N/A	140	150
900	N/A	130	150
1050	N/A	130	140
1200	N/A	130	140
1350	N/A	120	140
1500	N/A	120	140
1650	N/A	N/A	130
1800	N/A	N/A	130
1950	N/A	N/A	130
2100	N/A	N/A	N/A
2250	N/A	N/A	N/A

Shading indicates preferred spring option

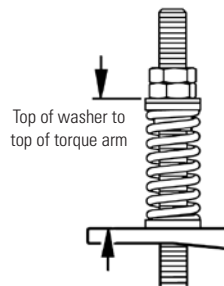

Pole Location Chart

A	X	Y	C
406	207	305	368
432	222	305	378
457	235	305	384
483	248	305	394
508	264	305	403
533	279	305	413
559	292	305	422
584	305	305	432
610	321	305	441
635	334	305	451
660	346	305	461
686	359	305	470
711	372	305	480
737	387	305	492
762	397	305	502
787	410	305	511
813	425	305	524
838	438	305	533
864	451	305	543
889	464	305	556
914	476	305	565
940	492	305	578
965	502	305	588
991	518	305	600
1016	527	305	610
1041	543	305	622
1067	552	305	632
1092	568	305	645
1118	578	305	654
1143	594	305	667
1168	607	305	679
1194	619	305	689
1219	632	305	702

Specifications:

- Maximum Belt Speed Contact Flexco®
- Temperature Rating -35°C to 82°C
- Minimum Pulley Diameter..... 400 mm
- Usable Blade Wear Length..... 150 mm
- Blade Polyurethane (proprietary blend for abrasion resistance and long wear)
- Available for Belt Widths 600 to 2100 mm
Other sizes available upon request

U.S. Patent No. D482,508S

Product Ordering Information

Line Connections for Portable Air Tensioner

ORDERING NUMBER	ITEM CODE	WT. Kg
PAT1	78684	5.9
PAT2	78685	5.9



PAT1 (Single)



PAT2 (Dual)

REF	DESCRIPTION	ORDERING NUMBER	ITEM CODE	WT. Kg
1	Tank Label Kit	PATLK	78791	0.05
2	Tank Hose Kit (incl. 1 ea. 10' hose and 1' poly spiral wrap, 2 hose clamps)	PATHK	78794	0.9

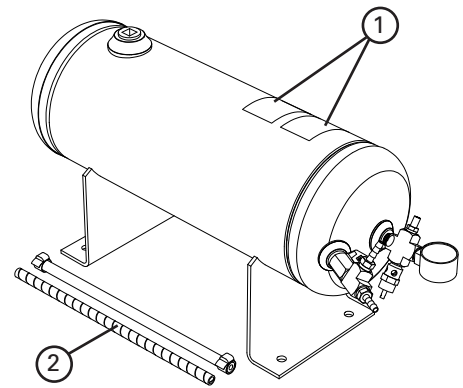

Product Notes:

- For use with PAT cleaner assemblies and PAT control box.
- Single for applications with one cleaner, double for applications with two cleaners.
- 150# pop-off valve for safe pressurizing/charging of Air Tank.
- ASME Construction.

 **Stock items** (non-shaded) refer to (*) for specific lead time, if not specified, standard lead time applies.

 **Non-stock items** (shaded) please contact Flexco for dispatch options and lead times.

Product Ordering Information

MHCP Heavy-Duty Cartridge Primary Cleaner

MHCP HD Cartridge Primary Cleaner with Spring Tensioner (PST)

BELT WIDTH mm	BLADE COVERAGE mm	ORDERING NUMBER	ITEM CODE	WT. KG.
600	450	MHCP-24S	75929	87.3
750	600	MHCP-30S	75930	94.2
900	750	MHCP-36S	75931	101.1
1050	900	MHCP-42S	75932	107.9
1200	1050	MHCP-48S	75933	114.8
1350	1200	MHCP-54S	75934	121.6
1500	1350	MHCP-60S	75935	128.5
1800	1650	MHCP-72S	75936	142.2
2100	1950	MHCP-84S	76800	165.9

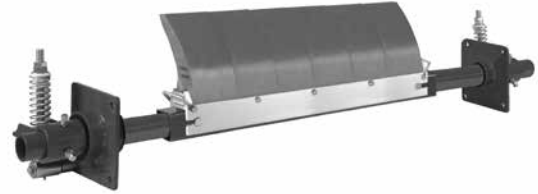

Mild Steel Model Pictured

MHCP HD Cartridge Primary Cleaner with Air/Water Tensioner (AWT)*

BELT WIDTH mm	BLADE COVERAGE mm	ORDERING NUMBER	ITEM CODE	WT. KG.
600	450	MHCP-24A	75937	87.4
750	600	MHCP-30A	75938	94.2
900	750	MHCP-36A	75939	101.1
1050	900	MHCP-42A	75940	107.9
1200	1050	MHCP-48A	75941	114.8
1350	1200	MHCP-54A	75942	121.6
1500	1350	MHCP-60A	75943	128.5
1800	1650	MHCP-72A	75944	142.2
2100	1950	MHCP-84A	76801	165.9



Mild Steel Model Pictured

Product Notes:

- Heavy-duty design with massive SuperShear™ blades for constant cleaning power on abusive beltlines.
- Blade width equals Belt Width minus 150 mm. Can be adjusted to belt's material path.
- Pole Length: Belt Width plus 1450 mm. For longer requirements see Mineliner® Installation Accessories - Pole Extender Kit .
- Tensioner Options: 1) PST Spring Tensioner for self-adjusting tensioning with easy retensioning adjustments; 2) AWT Air/Water Tensioner for automatic tensioning throughout the life of the blades.

Stock items (non-shaded) refer to (*) for specific lead time, if not specified, standard lead time applies.

Non-stock items (shaded) please contact Flexco for dispatch options and lead times.

Specifications & Guidelines

MHCP Heavy-Duty Cartridge Primary Cleaner

Telescoping Pole Length Specifications

CLEANER SIZE mm	MAX OVERALL POLE LENGTH ITEM CODE mm	CENTRE POLE LENGTH mm	MAXIMUM CONVEYOR SPAN mm
600	2050	700	1650
750	2200	850	1800
900	2350	1000	1950
1050	2500	1150	2100
1200	2650	1300	2250
1350	2800	1450	2400
1500	2950	1600	2550
1800	3250	1900	2850
2100	3550	2200	3150

Pole Diameter - 73 mm

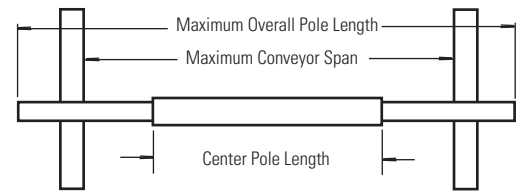

Pole Location Specs

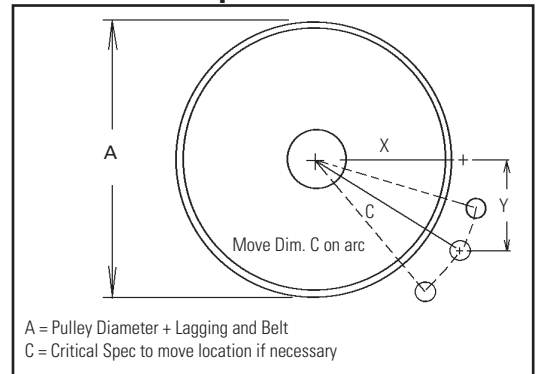

Clearance Guidelines for Installation

HORIZONTAL CLEARANCE REQUIRED mm	VERTICAL CLEARANCE REQUIRED mm
175	475

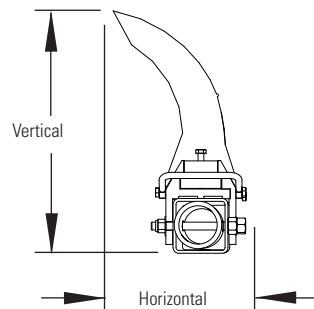

Spring Length Chart with PST Spring Tensioner

BLADE WIDTH mm	NO. OF BLADES	WHITE SPRINGS mm	SILVER SPRINGS mm
450	3	140	160
600	4	130	150
750	5	130	150
900	6	120	150
1050	7	110	150
1200	8	N/A	140
1350	9	N/A	140
1500	10	N/A	140
1650	11	N/A	140
1800	12	N/A	130
1950	13	N/A	130

Shading indicates preferred spring option
Spring tension is based on the number of blades on the cleaner, not the Belt Width.

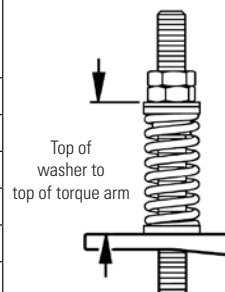

Air/Water Chart

BLADE WIDTH mm	BLADES	PSI
450	3	8#
600	4	10#
750	5	13#
900	6	15#
1050	7	18#
1200	8	20#
1350	9	23#
1500	10	25#
1650	11	28#
1950	12	31#

PSI setting is based on the number of blades on the cleaner, not the Belt Width.

Pole Location Chart

A	X	Y	C
508	254	365	445
533	267	365	451
559	279	365	461
584	292	365	467
610	305	365	476
635	318	365	483
660	330	365	492
686	343	365	502
711	356	365	511
737	368	365	518
762	381	365	527
787	394	365	537
813	406	365	546
838	419	365	556
864	432	365	565
889	445	365	575
914	457	365	584
940	470	365	594
965	483	365	607
991	495	365	616
1016	508	365	626
1041	521	365	635
1067	533	365	648
1092	546	365	657
1118	559	365	667
1143	572	365	679
1168	584	365	689
1194	591	365	699
1219	610	365	711

Specifications:

- Maximum Belt SpeedContact Flexco®
- Temperature Rating-35°C to 82°C
- Minimum Pulley Diameter.....400 mm
- Usable Blade Wear Length.....200 mm
- BladesPolyurethane (proprietary blend for abrasion resistance and long wear)
- Available for Belt Widths600 to 2100 mm
Other sizes available upon request.

Replacement Parts List

MHCP Heavy-Duty Cartridge Primary Cleaner

Replacement Parts List

REF	DESCRIPTION	ORDERING NUMBER	ITEM CODE	WT. KG.
1	600 mm Centre Pole*	MHP-CP600	75961	8.6
	750 mm Centre Pole*	MHP-CP750	75962	10.5
	900 mm Centre Pole*	MHP-CP900	75963	12.4
	1050 mm Centre Pole*	MHP-CP1050	75964	14.2
	1200 mm Centre Pole*	MHP-CP1200	75965	16.1
	1350 mm Centre Pole*	MHP-CP1400	75966	17.9
	1500 mm Centre Pole*	MHP-CP1500	75967	19.8
	1800 mm Centre Pole*	MHP-CP1800	75968	23.5
	2100 mm Centre Pole*	MHP-CP2100	76811	27.4
2	MHCP Extender Poles (2 ea.)	MHP-EP	76392	24.6
3	SuperShear™ Blade	SSRB	75978	3.0
3a	SuperShear™ FRAS Blade	SSFRB	78456	3.0
4	600 mm 2-Piece Blade Cartridge*	MHCP-2BC24	76638	6.0
	750 mm 2-Piece Blade Cartridge*	MHCP-2BC30	76639	8.0
	900 mm 2-Piece Blade Cartridge*	MHCP-2BC36	76640	10.0
	1050 mm 2-Piece Blade Cartridge*	MHCP-2BC42	76641	12.0
	1200 mm 2-Piece Blade Cartridge*	MHCP-2BC48	76642	14.0
	1350 mm 2-Piece Blade Cartridge*	MHCP-2BC54	76643	16.0
	1500 mm 2-Piece Blade Cartridge*	MHCP-2BC60	76644	18.0
	1800 mm 2-Piece Blade Cartridge*	MHCP-2BC72	76645	22.0
	2100 mm 2-Piece Blade Cartridge*	MHCP-2BC84	76812	25.7
5	MHCP Cartridge Handle*	MHCP-CH	76393	0.2
6	MHCP Cartridge Blade Stop*	MHCP-BS	76394	0.2



Blades Required per Belt Width

BELT WIDTH mm	BLADE COVERAGE mm	BLADES REQUIRED
600	450	3
750	600	4
900	750	5
1050	900	6
1200	1050	7
1350	1200	8
1500	1350	9
1800	1650	11
2100	1950	13

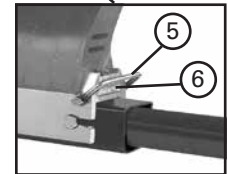

Blades and cartridges can be purchased separately (see chart at left) or preassembled as a Blade Cartridge Kit

PST Spring Tensioner Replacement Parts

REF	DESCRIPTION	ORDERING NUMBER	ITEM CODE	WT. KG.
7	Mounting Base* (1 ea.)	PMB	75895	10.1
8	Torque Arm* (1 ea.)	PSTA	75896	5.1
9	Torque Pivot Kit (1 ea.) (no spring)	PTPK	75897	3.2
10	Tension Spring - White (1 ea.) for belts 600-1200 mm	PSTS-W	75898	0.8
10a	Tension Spring - Silver (1 ea.) for belts 1350-2100 mm	PSTS-S	75899	1.4
11	Bushing Kit (2 ea.) (for White & Silver Tensioners)	QMTBK-W	76098	0.1
	PST Spring Tensioner* - White (includes 2 each items 7, 8, 9, 10 & 11) for belts 600-1200 mm	PST2-W	77723	39.1
	PST Spring Tensioner* - Silver (includes 2 each items 7, 8, 9, 10a & 11) for belts 1350-2100 mm	PST2-S	77724	39.2

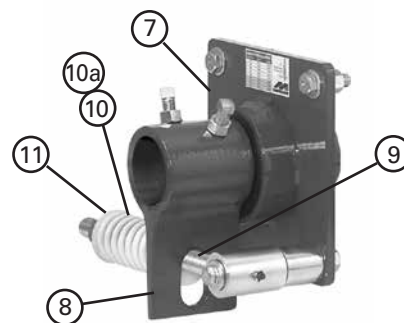

Air/Water Tensioner Replacement Parts

REF	DESCRIPTION	ORDERING NUMBER	ITEM CODE	WT. KG.
12	Air/Water Bag (1 ea.)	AWTB	75905	1.7
13	Mounting Base (1 ea.)	AWTMB	75906	10.4
14	Torque Arm* (1 ea.)	AWTA	75907	5.3
15	Hose Kit (15 M of hose and 6 hose clamps)	AWTHK	75909	3.1
16	Control Box (Complete)	AWTCB	75908	0.5
-	AWT Air/Water Tensioner (includes 2 each items 12, 13, & 14 and 1 each items 15 & 16)	AWT	75904	39.2
-	AWT Air/Water Tensioner w/o Control Box (includes 2 each items 12, 13, 14 & 1 each item 15)	AWTNCB	76069	34.2
-	AWT Air/Water Tensioner w/o Control Box, 1 side (includes 1 each items 12, 13, 14 & 15)	AWT-1S	76375	17.1

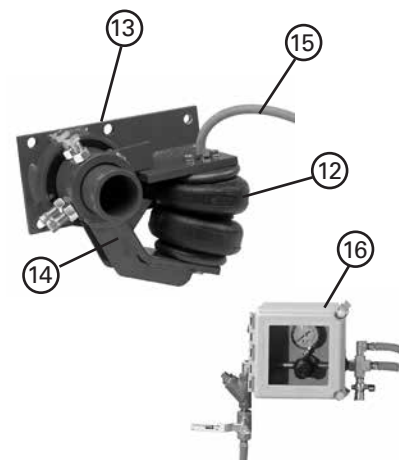

*Hardware Included

Stock items (non-shaded) refer to (*) for specific lead time, if not specified, standard lead time applies.
Non-stock items (shaded) please contact Flexco for dispatch options and lead times.

Product Ordering Information

MHCP Stainless Steel Heavy-Duty Cartridge Primary Cleaner

MHCP S/S HD Cartridge Primary Cleaner with Spring Tensioner (PST)

BELT WIDTH mm	ORDERING NUMBER	ITEM CODE	WT. KG.
600	MHCP-600S-S/S	61504	81.0
750	MHCP-750S-S/S	61505	89.4
900	MHCP-900S-S/S	61506	97.8
1050	MHCP-1050S-S/S	61507	108.1
1200	MHCP-1200S-S/S	61508	116.4
1350	MHCP-1350S-S/S	61509	124.8
1500	MHCP-1500S-S/S	61510	133.1
1650	MHCP-1650S-S/S	61511	141.4
1800	MHCP-1800S-S/S	61512	149.7
2100	MHCP-2100S-S/S	61513	166.7

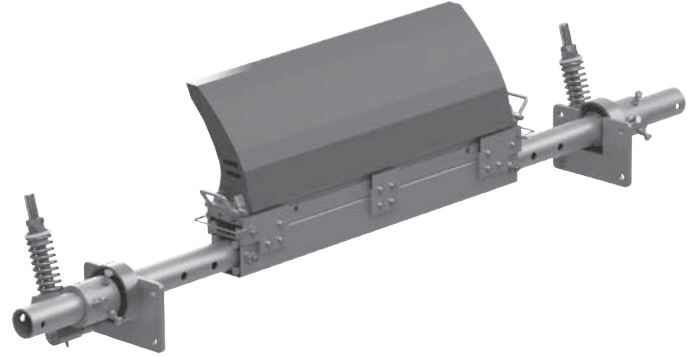

MHCP S/S FRAS HD Cartridge Primary Cleaner with Spring Tensioner (PST)

BELT WIDTH mm	ORDERING NUMBER	ITEM CODE	WT. KG.
600	MHCP-600S-S/S-FR	61624	81.0
750	MHCP-750S-S/S-FR	61625	89.4
900	MHCP-900S-S/S-FR	61626	97.8
1050	MHCP-1050S-S/S-FR	61627	108.1
1200	MHCP-1200S-S/S-FR	61628	116.4
1350	MHCP-1350S-S/S-FR	61629	124.8
1500	MHCP-1500S-S/S-FR	61630	133.1
1650	MHCP-1650S-S/S-FR	61631	141.4
1800	MHCP-1800S-S/S-FR	61632	149.7
2100	MHCP-2100S-S/S-FR	61633	166.7

Product Notes:

- Works with mechanical fasteners. The shock-absorbing tensioners and the force distributor vents in the blades allow mechanical splices, skived or unskived, to pass without damage to the splice or the cleaner and with minimal cleaning disruption..
- Complete cleaning system. When teamed with the MHS HD Secondary Cleaner, it makes up a system that delivers maximum cleaning power for the most abusive conveyor applications.
- Made for mining conveyors. Made from heavy-duty, corrosion-resistant steel, the MHCP is available in sizes for belt widths from 600 to 2100mm. Additional sizes are available upon request.
- Stainless steel. Corrosive environments wear on any component, but stainless steel can protect against that.

Stock items (non-shaded) refer to (*) for specific lead time, if not specified, standard lead time applies.

Non-stock items (shaded) please contact Flexco for dispatch options and lead times.

Specifications & Guidelines

MHCP Stainless Steel Heavy-Duty Cartridge Primary Cleaner

Telescoping Pole Length Specifications

Cleaner Size		Max Overall Pole Length		Centre Pole Length		Maximum Conveyor Span	
in.	mm	in.	mm	in.	mm	in.	mm
24	600	81	2020	20	511	65	1620
30	750	87	2173	27	663	71	1773
36	900	93	2325	33	815	77	1925
42	1050	99	2478	39	968	83	2078
48	1200	105	2630	45	1120	89	2230
54	1350	111	2783	51	1273	95	2383
60	1500	117	2935	57	1425	101	2535
66	1650	123	3087	63	1577	107	2687
72	1800	130	3240	69	1730	114	2840
84	2100	142	3545	81	2035	126	3145

Pole Diameter - 2-7/8" (73mm)

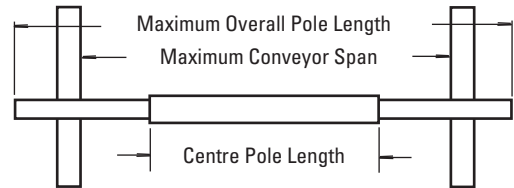

Clearance Guidelines for Installation

Horizontal Clearance Required		Vertical Clearance Required	
in.	mm	in.	mm
7	175	19	475

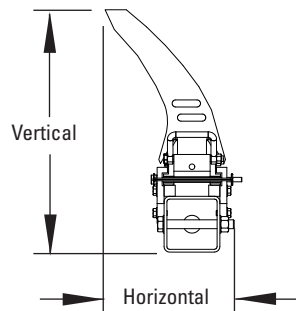

Spring Length Chart with PST Spring Tensioner

Blade Width	No. Of Blades	White Springs	Silver Springs
600	3	142	162
750	4	149	159
900	5	143	156
1050	6	140	156
1200	7	133	152
1350	8	N/A	149
1500	9	N/A	146
1650	10	N/A	146
1800	11	N/A	143
2100	13	N/A	140

Spring tension is based on the number of blades on the cleaner, not the belt width. Shading indicates preferred spring option.

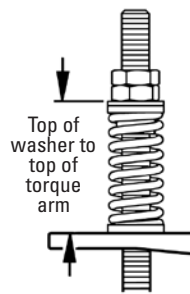

Pole Location Specs

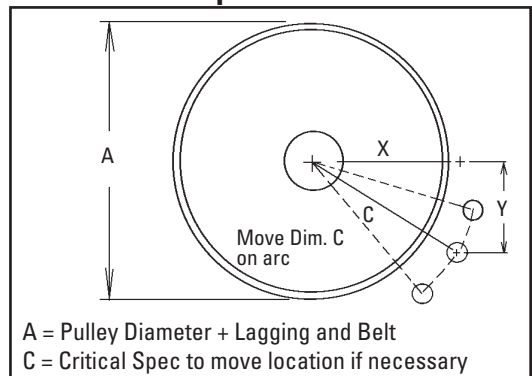

Pole Location Chart

A	X	C
500	229	473
525	242	479
550	254	486
575	267	492
600	279	499
625	292	506
650	304	514
675	317	521
700	329	529
725	342	537
750	354	545
775	367	553
800	379	561
825	392	570
850	404	578
875	417	587
900	429	596
925	442	605
950	454	614
975	467	624
1000	479	633
1025	492	643
1050	504	652
1075	517	662
1100	529	672
1125	542	682
1150	554	692
1175	567	702
1200	579	712

Specifications:

- Maximum Belt Speed6M/sec
- Temperature Rating-35°C to 82°C
- Minimum Pulley Diameter500mm
- Blade Height350mm
- Usable Blade Wear Length200mm
- BladesPolyurethane (proprietary blend for abrasion resistance and long wear).
- Available for Belt Widths.....600 to 2400mm.
Other sizes available upon request.

Replacement Parts List

MHCP Stainless Steel Heavy-Duty Cartridge Primary Cleaner

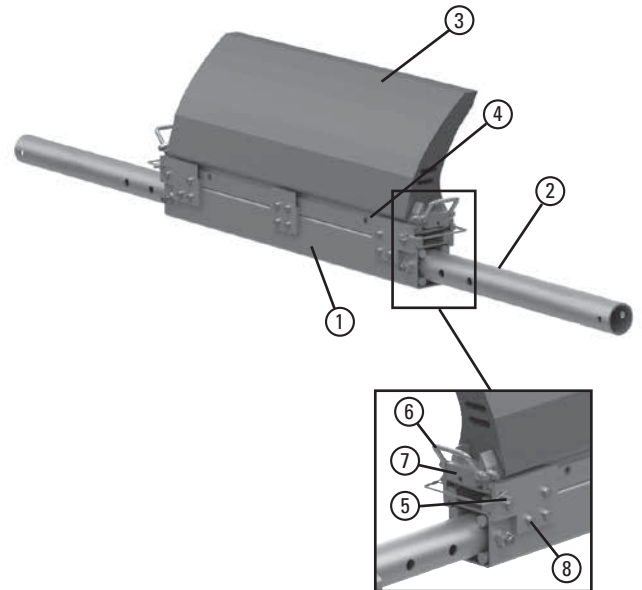

Replacement Parts

REF	DESCRIPTION	ORDERING NUMBER	ITEM CODE	WT. KG.
1	24" (600mm) Centre Pole*	MHCP-S/S-CP 600	61634	15.9
	30" (750mm) Centre Pole*	MHCP-S/S-CP 750	61525	19.1
	36" (900mm) Centre Pole*	MHCP-S/S-CP 900	61526	22.3
	42" (1050mm) Centre Pole*	MHCP-S/S-CP 1050	61527	27.4
	48" (1200mm) Centre Pole*	MHCP-S/S-CP 1200	61528	30.6
	54" (1350mm) Centre Pole*	MHCP-S/S-CP 1350	61529	33.8
	60" (1500mm) Centre Pole*	MHCP-S/S-CP 1500	61530	37.0
	66" (1650mm) Centre Pole*	MHCP-S/S-CP 1650	61531	40.2
	72" (1800mm) Centre Pole*	MHCP-S/S-CP 1800	61532	43.5
84" (2100mm) Centre Pole*	MHCP-S/S-CP 2100	61533	49.9	
2	MHCP S/S Extender Poles (2 ea.)	MHCP-SS/EP	61534	20.1
3	SuperShear™ Blade	SSRB	75978	3.0
3a	SuperShear™ FRAS Blade	SSFRB	78456	3.0
4	24" (600mm) Cartridge Kits*	MHCP-S/S-CK600	61535	9.3
	30" (750mm) Cartridge Kits*	MHCP-S/S-CK750	61536	11.7
	36" (900mm) Cartridge Kits*	MHCP-S/S-CK900	61537	14.0
	42" (1050mm) Cartridge Kits*	MHCP-S/S-CK1050	61538	16.3
	48" (1200mm) Cartridge Kits*	MHCP-S/S-CK1200	61539	18.6
	54" (1350mm) Cartridge Kits*	MHCP-S/S-CK1350	61540	21.0
	60" (1500mm) Cartridge Kits*	MHCP-S/S-CK1500	61541	23.3
	66" (1650mm) Cartridge Kits*	MHCP-S/S-CK1650	61542	25.6
	72" (1800mm) Cartridge Kits*	MHCP-S/S-CK1800	61543	28.0
84" (2100mm) Cartridge Kits*	MHCP-S/S-CK2100	61544	32.3	
5	MHCP S/S Cartridge Locking Pin	MHCP-S/S-CLP	61545	0.1
6	MHCP S/S Cartridge Handle*	MHCP-S/S-CH	61548	0.1
7	MHCP S/S Cartridge End Block*	MHCP-S/S-CEB	61549	0.5
8	MHCP S/S Cartridge Bolt Kit	MHCP-S/S-CBK	61550	0.1

*Hardware Included

Blades Required per Belt Width

Belt Width		Blades Required
in.	mm	
24	600	3
30	750	4
36	900	5
42	1050	6
48	1200	7
54	1350	8
60	1500	9
66	1650	10
72	1800	11
84	2100	13

Blades and cartridges can be purchased separately (see chart at left) or preassembled as a Blade Cartridge Kit.

PST Spring Tensioner Replacement Parts

REF	DESCRIPTION	ORDERING NUMBER	ITEM CODE	WT. KG.
9	Tension Spring - White (1 ea.) for belts 24" - 48" (600-1200mm)	PSTS-W	75898	0.8
9a	Tension Spring - Silver (1 ea.) for belts 54" - 96" (1350-2400mm)	PSTS-S	75899	1.4
10	Bushing Kit (2 ea.) for White & Silver Tensioners	QMTBK-W	76098	0.2
-	PST Spring Tensioner* - White (includes 2 ea.) for belts 600-1200mm (24" - 48")	MHCP-S/S-PSTW	61546	27.6
-	PST Spring Tensioner* - Silver (includes 2 ea.) for belts 1350-2400mm (54" - 96")	MHCP-S/S-PSTS	61547	27.7

*Hardware Included

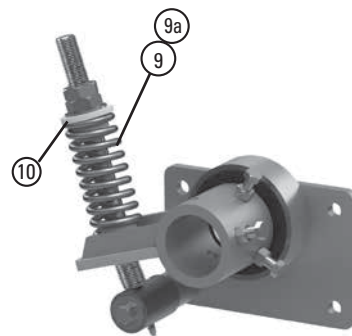

Product Ordering Information

H-Type® with XF-Tips Segmented Blade Primary Cleaner

H-Type® with XF-Tips Powder Coated

BELT WIDTH mm	HF-TIP SIZE	ORDERING NUMBER	ITEM CODE	WT. KG.
450	S	HXF450S	74659	35.0
450	M	HXF450M	74660	
600	S	HXF600S	74661	41.0
600	M	HXF600M	74662	
750	S	HXF750S	74663	42.0
750	M	HXF750M	74664	
900	S	HXF900S	74665	47.0
900	M	HXF900M	74666	
900	L	HXF900L	74667	
1050	S	HXF1050S	74668	60.0
1050	M	HXF1050M	74669	
1050	L	HXF1050L	74670	
1200	S	HXF1200S	74671	62.0
1200	M	HXF1200M	74672	
1200	L	HXF1200L	74673	
1500	M	HXF1500M	74677	75.0
1500	L	HXF1500L	74678	
1600	M	HXF1600M	73443	80.0
1600	L	HXF1600L	73444	
1800	M	HXFHD1800M	74681	105.0
1800	L	HXFHD1800L	74682	
2100	M	HXFHD2100M	74683	110.0
2100	L	HXFHD2100L	74684	
2400	M	HXFHD2400M	74685	120.0
2400	L	HXFHD2400L	74686	

Tips Required Per Cleaner Size

BELT WIDTH mm	BLADE COVERAGE mm	XF-TIPS REQUIRED
450	400	2
600	600	3
750	600	3
900	800	4
1050	1000	5
1200	1200	6
1500	1400	7
1600	1600	8
1800	1800	9
2100	2000	10
2400	2400	12

Product Notes:

- All cleaners supplied with dual tensioners.
- Also available with J-Bolt Side Assembly.
- Standard supply is non-FRAS.
- Specify when ordering FRAS.
- Specify arm size when ordering.
- For other replacement parts, please refer to page 42.

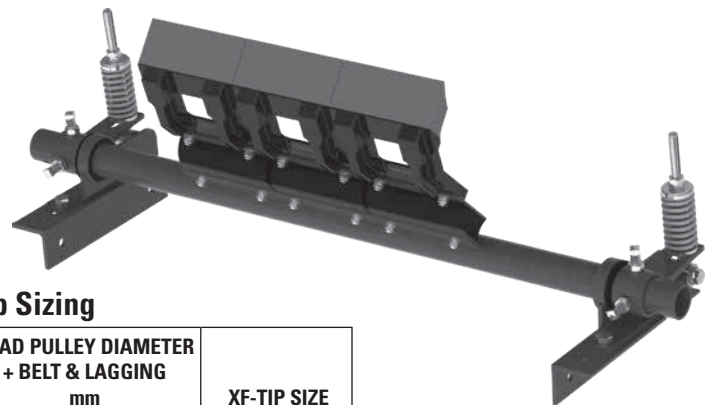

Tip Sizing

HEAD PULLEY DIAMETER + BELT & LAGGING mm	XF-TIP SIZE
up to 499	SS
500-799	S
800-999	M
1000-1200	L

Over 1200 mm - contact Flexco®.

Replacement XF8-Non-FRAS Tips

SIZE	ORDERING NUMBER	COLOUR	ITEM CODE	WT. KG.
SS	HXF8SS	Purple	74307	1.5
S	HXF8S	Purple	74689	1.7
M	HXF8M	Purple	74690	1.8
L	HXF8L	Purple	74691	2.0

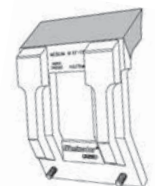

Replacement XF8-FRAS Tips

SIZE	ORDERING NUMBER	COLOUR	ITEM CODE	WT. KG.
SS	HXF8SS-Blue	Blue	77518	2.0
S	HXF8S-Blue	Blue	77519	2.0
M	HXF8M-Blue	Blue	77520	2.0
L	HXF8L-Blue	Blue	77521	2.5



Replacement XF2-Non-FRAS Tips

SIZE	ORDERING NUMBER	COLOUR	ITEM CODE	WT. KG.
SS	HXF2-SS	Purple	75979	1.5
S	HXF2-S	Purple	75980	1.5
M	HXF2-M	Purple	75981	1.5
L	HXF2-L	Purple	75982	2.0

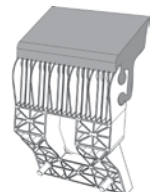

Specially formulated, long-wearing polyurethane blade tip.
Impact-resistant, reinforced nylon base for rigidity and minimal deflection.

Stock items (non-shaded) refer to (*) for specific lead time, if not specified, standard lead time applies.

Non-stock items (shaded) please contact Flexco for dispatch options and lead times.

Product Ordering Information

H-Type® with XF-Tips Segmented Blade Primary Cleaner Stainless Steel

H-Type® with XF-Tips Stainless Steel

BELT WIDTH mm	XF2-TIP SIZE	ORDERING NUMBER	ITEM CODE	WT. KG.
450	S	HXF450S-S/S	75266	35.0
450	M	HXF450M-S/S	75267	
600	S	HXF600S-S/S	75268	42.0
600	M	HXF600M-S/S	75269	
750	S	HXF750S-S/S	75270	43.0
750	M	HXF750M-S/S	75271	
900	S	HXF900S-S/S	75272	49.0
900	M	HXF900M-S/S	75273	
900	L	HXF900L-S/S	75274	
1050	S	HXF1050S-S/S	75275	62.0
1050	M	HXF1050M-S/S	75276	
1050	L	HXF1050L-S/S	75277	
1200	S	HXF1200S-S/S	75278	63.0
1200	M	HXF1200M-S/S	75279	
1200	L	HXF1200L-S/S	75280	
1500	M	HXF1500M-S/S	75281	77.0
1500	L	HXF1500L-S/S	75282	
1600	M	HXF1600M-S/S	75283	82.0
1600	L	HXF1600L-S/S	75284	
1800	M	HXFHD1800M-S/S	A1588	107.0
1800	L	HXFHD1800L-S/S	A1589	
2100	M	HXFHD2100M-S/S	A1590	112.0
2100	L	HXFHD2100L-S/S	A1591	
2400	M	HXFHD2400M-S/S	A1592	122.0
2400	L	HXFHD2400L-S/S	A1593	

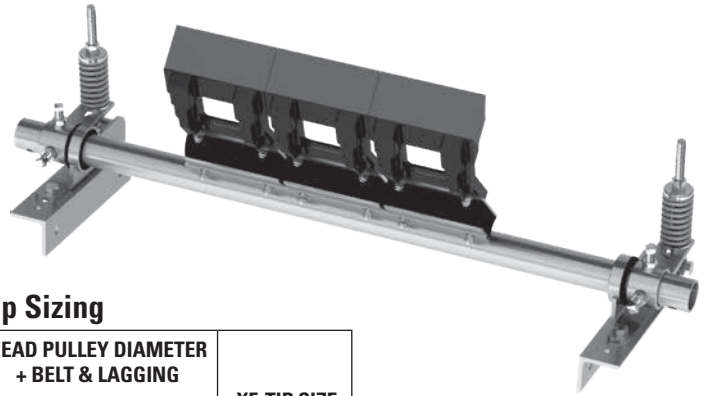

Tip Sizing

HEAD PULLEY DIAMETER + BELT & LAGGING mm	XF-TIP SIZE
up to 499	SS
500-799	S
800-999	M
1000-1200	L

Over 1200 mm- contact Flexco®.

Replacement XF8-Non-FRAS Tips

SIZE	ORDERING NUMBER	COLOUR	ITEM CODE	WT. KG.
SS	HXF8SS	Purple	74307	1.5
S	HXF8S	Purple	74689	1.7
M	HXF8M	Purple	74690	1.8
L	HXF8L	Purple	74691	2.0



Replacement XF8-FRAS Tips

SIZE	ORDERING NUMBER	COLOUR	ITEM CODE	WT. KG.
SS	HXF8SS-Blue	Blue	77518	2.0
S	HXF8S-Blue	Blue	77519	2.0
M	HXF8M-Blue	Blue	77520	2.0
L	HXF8L-Blue	Blue	77521	2.5



Replacement XF2-Non-FRAS Tips

SIZE	ORDERING NUMBER	COLOUR	ITEM CODE	WT. KG.
SS	HXF2-SS	Purple	75979	1.5
S	HXF2-S	Purple	75980	1.5
M	HXF2-M	Purple	75981	1.5
L	HXF2-L	Purple	75982	2.0

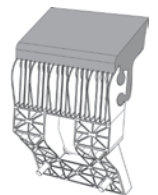

Specially formulated, long-wearing polyurethane blade tip. Impact-resistant, reinforced nylon base for rigidity and minimal deflection.

Tips Required Per Cleaner Size

BELT WIDTH mm	BLADE COVERAGE mm	XF-TIPS REQUIRED
450	400	2
600	600	3
750	600	3
900	800	4
1050	1000	5
1200	1200	6
1500	1400	7
1600	1600	8
1800	1800	9
2100	2000	10
2400	2400	12

Product Notes:

- All cleaners supplied with dual tensioners.
- Also available with J-Bolt Side Assembly.
- Standard supply is non-FRAS.
- Specify when ordering FRAS.
- Specify arm size when ordering.
- For replacement parts refer to page 42.

Stock items (non-shaded) refer to (*) for specific lead time, if not specified, standard lead time applies.

Non-stock items (shaded) please contact Flexco for dispatch options and lead times.

Product Ordering Information

H-Type® with V-Tips Segmented Blade Primary Cleaner

H-Type® with V-Tips*-Powder Coated

BELT WIDTH mm	SUSPENSION ARM SIZE	ORDERING NUMBER	ITEM CODE	WT. KG.
450	SS	HV450SS	73026	30.0
450	S	HV450S	73028	
450	M	HV450M	73019	
600	SS	HV600SS	73045	35.0
600	S	HV600S	73030	
600	M	HV600M	73173	
750	SS	HV750SS	73053	37.0
750	S	HV750S	73032	
750	M	HV750M	73174	
900	SS	HV900SS	73055	42.0
900	S	HV900S	73034	
900	M	HV900M	73175	
900	L	HV900L	73178	46.0
1050	SS	HV1050SS	73057	
1050	S	HV1050S	73056	
1050	M	HV1050M	73036	50.0
1050	L	HV1050L	73179	
1200	SS	HV1200SS	73059	
1200	S	HV1200S	73058	64.0
1200	M	HV1200M	73038	
1200	L	HV1200L	73180	
1500	M	HV1500M	73177	68.0
1500	L	HV1500L	73158	
1500	LL	HV1500LL	73215	
1600	M	HV1600M	73637	95.0
1600	L	HV1600L	73638	
1600	LL	HV1600LL	73639	
1800	M	HVHD1800M	74602	102.0
1800	L	HVHD1800L	74477	
1800	LL	HVHD1800LL	74478	
2100	M	HVHD2100M	74539	118.0
2100	L	HVHD2100L	74540	
2100	LL	HVHD2100LL	74541	
2400	M	HVHD2400M	74544	125.0
2400	L	HVHD2400L	74545	
2400	LL	HVHD2400LL	74546	
2600	M	HVHD2600M	A2396	133.0
2600	L	HVHD2600L	A2461	
2600	LL	HVHD2600LL	A2397	
3000	M	HVHD3000M	74591	133.0
3000	L	HVHD3000L	74592	
3000	LL	HVHD3000LL	74593	

Specify arm size when ordering.



Suspension Arm Size

HEAD PULLEY DIAMETER + BELT & LAGGING mm	SUSPENSION ARM SIZE
up to 499	SS
500-799	S
800-999	M
1000-1199	L
1200-1700	LL

Over 1700 mm—contact Flexco®.

Replacement V-Tips

ORDERING NUMBER	ITEM CODE	WT. KG.
HSA200	73489	0.5
HVPT-S/S	73631	1.2

Replacement Suspension Arms

SIZE	ORDERING NUMBER	ITEM CODE	WT. KG.
SS	HSA8SS	73047	0.9
S	HSA8S	73048	1.1
M	HSA8M	73049	1.3
L	HSA8L	73063	1.5
LL	HSA8LL	73064	1.7

Tips Required Per Cleaner Size

BELT WIDTH mm	BLADE COVERAGE mm	V-TIPS REQUIRED
450	400	2
600	600	3
750	600	3
900	800	4
1050	1000	5
1200	1200	6
1500	1400	7
1600	1600	8
1800	1800	9
2100	2000	10
2400	2400	12
2600	2600	13
3000	3000	15

Stock items (non-shaded) refer to (*) for specific lead time, if not specified, standard lead time applies.

Non-stock items (shaded) please contact Flexco for dispatch options and lead times.

Product Ordering Information

H-Type® with V-Tips Segmented Blade Primary Cleaner Stainless Steel

H-Type® with V-Tips*-Stainless Steel

BELT WIDTH mm	SUSPENSION ARM SIZE	ORDERING NUMBER	ITEM CODE	WT. KG.
450	SS	HV450SS-S/S	75293	30.0
450	S	HV450S-S/S	75294	
450	M	HV450M-S/S	75295	
600	SS	HV600SS-S/S	75296	36.0
600	S	HV600S-S/S	75297	
600	M	HV600M-S/S	75298	
750	SS	HV750SS-S/S	75299	38.0
750	S	HV750S-S/S	75300	
750	M	HV750M-S/S	75301	
900	SS	HV900SS-S/S	75302	43.0
900	S	HV900S-S/S	75303	
900	M	HV900M-S/S	75304	
900	L	HV900L-S/S	75305	47.0
1050	SS	HV1050SS-S/S	75306	
1050	S	HV1050S-S/S	75307	
1050	M	HV1050M-S/S	75308	50.0
1050	L	HV1050L-S/S	75309	
1200	SS	HV1200SS-S/S	75310	
1200	S	HV1200S-S/S	75311	64.0
1200	M	HV1200M-S/S	75312	
1200	L	HV1200L-S/S	75313	
1500	M	HV1500M-S/S	75314	68.0
1500	L	HV1500L-S/S	75315	
1500	LL	HV1500LL-S/S	75316	
1600	M	HV1600M-S/S	75317	98.0
1600	L	HV1600L-S/S	75318	
1600	LL	HV1600LL-S/S	75319	
1800	M	HVHD1800M-S/S	A1594	104.0
1800	L	HVHD1800L-S/S	A1595	
1800	LL	HVHD1800LL-S/S	A1596	
2100	M	HVHD2100M-S/S	A1597	121.0
2100	L	HVHD2100L-S/S	A1598	
2100	LL	HVHD2100LL-S/S	A1599	
2400	M	HVHD2400M-S/S	A1600	125.0
2400	L	HVHD2400L-S/S	A1601	
2400	LL	HVHD2400LL-S/S	A1602	
2600	M	HVHD2600M-S/S	A2462	135.0
2600	L	HVHD2600L-S/S	A2463	
2600	LL	HVHD2600LL-S/S	A2464	
3000	M	HVHD3000M-S/S	A2465	
3000	L	HVHD3000L-S/S	A2466	
3000	LL	HVHD3000LL-S/S	A2467	

Specify arm size when ordering.

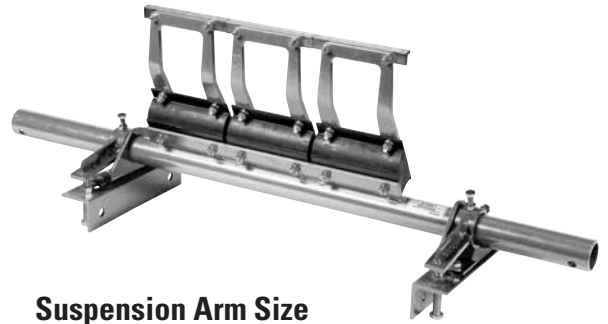

Suspension Arm Size

HEAD PULLEY DIAMETER + BELT & LAGGING mm	SUSPENSION ARM SIZE
up to 499	SS
500-799	S
800-999	M
1000-1199	L
1200-1700	LL

Over 1700 mm—contact Flexco®.

Replacement V-Tips

ORDERING NUMBER	ITEM CODE	WT. KG.
HVT8-S/S	75419	0.5
HVPT-S/S	73631	1.2

Replacement Suspension Arms

SIZE	ORDERING NUMBER	ITEM CODE	WT. KG.
SSS	HSA8SSS	75565	0.7
SS	HSA8SS-S/S	73771	0.9
S	HSA8S-S/S	73772	1.1
M	HSA8M-S/S	73773	1.3
L	HSA8L-S/S	73774	1.5
LL	HSA8LL-S/S	74033	1.7

Tips Required Per Cleaner Size

BELT WIDTH mm	BLADE COVERAGE mm	V-TIPS REQUIRED
450	400	2
600	600	3
750	600	3
900	800	4
1050	1000	5
1200	1200	6
1500	1400	7
1600	1600	8
1800	1800	9
2100	2000	10
2400	2400	12
2600	2600	13
3000	3000	15

Stock items (non-shaded) refer to (*) for specific lead time, if not specified, standard lead time applies.

Non-stock items (shaded) please contact Flexco for dispatch options and lead times.

Product Ordering Information

H-Type® with V-Tips and PCSTensioner Segmented Blade Primary Cleaner

H-Type® with V-Tips*-Powder Coated

BELT WIDTH mm	SUSPENSION ARM SIZE	ORDERING NUMBER	ITEM CODE	WT. KG.
450	SS	HV450SS-PCST	63936	36.8
450	S	HV450S-PCST	63937	
450	M	HV450M-PCST	63938	
600	SS	HV600SS-PCST	63939	41.8
600	S	HV600S-PCST	63940	
600	M	HV600M-PCST	63941	
750	SS	HV750SS-PCST	63942	43.8
750	S	HV750S-PCST	63943	
750	M	HV750M-PCST	63944	
900	SS	HV900SS-PCST	63945	48.8
900	S	HV900S-PCST	63946	
900	M	HV900M-PCST	63947	
900	L	HV900L-PCST	63948	52.8
1050	SS	HV1050SS-PCST	64045	
1050	S	HV1050S-PCST	63950	
1050	M	HV1050M-PCST	63951	56.8
1050	L	HV1050L-PCST	63952	
1200	SS	HV1200SS-PCST	63953	
1200	S	HV1200S-PCST	63954	70.8
1200	M	HV1200M-PCST	63955	
1200	L	HV1200L-PCST	63956	
1500	M	HV1500M-PCST	63957	74.8
1500	L	HV1500L-PCST	63958	
1500	LL	HV1500LL-PCST	63959	
1600	M	HV1600M-PCST	63960	101.8
1600	L	HV1600L-PCST	63961	
1600	LL	HV1600LL-PCST	63962	
1800	M	HV1800M-PCST	63963	108.8
1800	L	HV1800L-PCST	63964	
1800	LL	HV1800LL-PCST	63965	
2100	M	HV2100M-PCST	63966	125.0
2100	L	HV2100L-PCST	63967	
2100	LL	HV2100LL-PCST	63968	
2400	M	HV2400M-PCST	63969	132.0
2400	L	HV2400L-PCST	63970	
2400	LL	HV2400LL-PCST	63971	
2600	M	HV2600M-PCST	63972	140.0
2600	L	HV2600L-PCST	63973	
2600	LL	HV2600LL-PCST	63974	
3000	M	HV3000M-PCST	63975	140.0
3000	L	HV3000L-PCST	63976	
3000	LL	HV3000LL-PCST	63977	

Specify arm size when ordering.

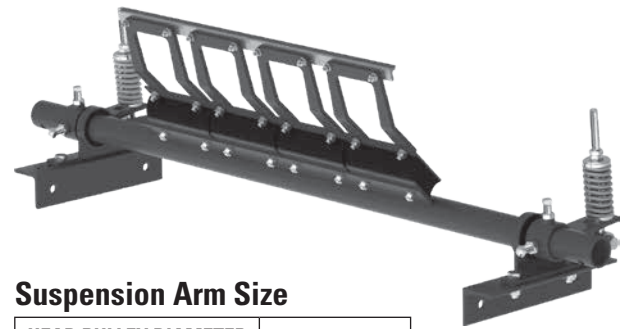

Suspension Arm Size

HEAD PULLEY DIAMETER + BELT & LAGGING mm	SUSPENSION ARM SIZE
up to 499	SS
500-799	S
800-999	M
1000-1199	L
1200-1700	LL

Over 1700 mm—contact Flexco®.

Replacement V-Tips

ORDERING NUMBER	ITEM CODE	WT. KG.
HSA200	73489	0.5
HVPT-S/S	73631	1.2

Replacement Suspension Arms

SIZE	ORDERING NUMBER	ITEM CODE	WT. KG.
SSS	HSA8SSS	75565	0.7
SS	HSA8SS	73047	0.9
S	HSA8S	73048	1.1
M	HSA8M	73049	1.3
L	HSA8L	73063	1.5
LL	HSA8LL	73064	1.7

Tips Required Per Cleaner Size

BELT WIDTH mm	BLADE COVERAGE mm	V-TIPS REQUIRED
450	400	2
600	600	3
750	600	3
900	800	4
1050	1000	5
1200	1200	6
1500	1400	7
1600	1600	8
1800	1800	9
2100	2000	10
2400	2400	12
2600	2600	13
3000	3000	15

Stock items (non-shaded) refer to (*) for specific lead time, if not specified, standard lead time applies.

Non-stock items (shaded) please contact Flexco for dispatch options and lead times.

Product Ordering Information

H-Type® with V-Tips and PCSTensioner Stainless Steel

H-Type® with V-Tips*-Stainless Steel

BELT WIDTH mm	SUSPENSION ARM SIZE	ORDERING NUMBER	ITEM CODE	WT. KG.
450	SS	HV450SS-PCST-S/S	63978	30.0
450	S	HV450S-PCST-S/S	63979	
450	M	HV450M-PCST-S/S	63980	
600	SS	HV600SS-PCST-S/S	63981	36.0
600	S	HV600S-PCST-S/S	63982	
600	M	HV600M-PCST-S/S	63983	
750	SS	HV750SS-PCST-S/S	63984	38.0
750	S	HV750S-PCST-S/S	63985	
750	M	HV750M-PCST-S/S	63986	
900	SS	HV900SS-PCST-S/S	63987	43.0
900	S	HV900S-PCST-S/S	63988	
900	M	HV900M-PCST-S/S	63989	
900	L	HV900L-PCST-S/S	63990	
1050	SS	HV1050SS-PCST-S/S	63991	47.0
1050	S	HV1050S-PCST-S/S	63992	
1050	M	HV1050M-PCST-S/S	63993	
1050	L	HV1050L-PCST-S/S	63994	
1200	SS	HV1200SS-PCST-S/S	63995	50.0
1200	S	HV1200S-PCST-S/S	63996	
1200	M	HV1200M-PCST-S/S	63997	
1200	L	HV1200L-PCST-S/S	63998	
1500	M	HV1500M-PCST-S/S	63999	64.0
1500	L	HV1500L-PCST-S/S	64000	
1500	LL	HV1500LL-PCST-S/S	64001	68.0
1600	M	HV1600M-PCST-S/S	64002	
1600	L	HV1600L-PCST-S/S	64003	98.0
1600	LL	HV1600LL-PCST-S/S	64004	
1800	M	HVHD1800M-PCST-S/S	64005	104.0
1800	L	HVHD1800L-PCST-S/S	64006	
1800	LL	HVHD1800LL-PCST-S/S	64007	
2100	M	HVHD2100M-PCST-S/S	64008	121.0
2100	L	HVHD2100L-PCST-S/S	64009	
2100	LL	HVHD2100LL-PCST-S/S	64010	
2400	M	HVHD2400M-PCST-S/S	64011	125.0
2400	L	HVHD2400L-PCST-S/S	64012	
2400	LL	HVHD2400LL-PCST-S/S	64013	
2600	M	HVHD2600M-PCST-S/S	64014	135.0
2600	L	HVHD2600L-PCST-S/S	64015	
2600	LL	HVHD2600LL-PCST-S/S	64016	
3000	M	HVHD3000M-PCST-S/S	64017	
3000	L	HVHD3000L-PCST-S/S	64018	
3000	LL	HVHD3000LL-PCST-S/S	64019	

Specify arm size when ordering.

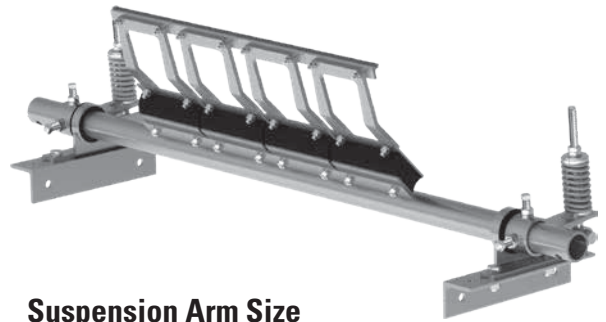

Suspension Arm Size

HEAD PULLEY DIAMETER + BELT & LAGGING mm	SUSPENSION ARM SIZE
up to 499	SS
500-799	S
800-999	M
1000-1199	L
1200-1700	LL

Over 1700 mm—contact Flexco®.

Replacement V-Tips

ORDERING NUMBER	ITEM CODE	WT. KG.
HVT8-S/S	75419	0.5
HVPT-S/S	73631	1.2

Replacement Suspension Arms

SIZE	ORDERING NUMBER	ITEM CODE	WT. KG.
SS	HSA8SS-S/S	73771	0.9
S	HSA8S-S/S	73772	1.1
M	HSA8M-S/S	73773	1.3
L	HSA8L-S/S	73774	1.5
LL	HSA8LL-S/S	74033	1.7

Tips Required Per Cleaner Size

BELT WIDTH mm	BLADE COVERAGE mm	V-TIPS REQUIRED
450	400	2
600	600	3
750	600	3
900	800	4
1050	1000	5
1200	1200	6
1500	1400	7
1600	1600	8
1800	1800	9
2100	2000	10
2400	2400	12
2600	2600	13
3000	3000	15

Stock items (non-shaded) refer to (*) for specific lead time, if not specified, standard lead time applies.

Non-stock items (shaded) please contact Flexco for dispatch options and lead times.

Replacement Parts List

H-Type® Segmented Blade Primary Cleaners

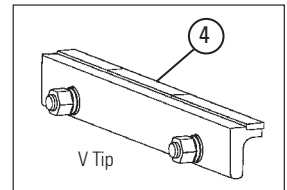
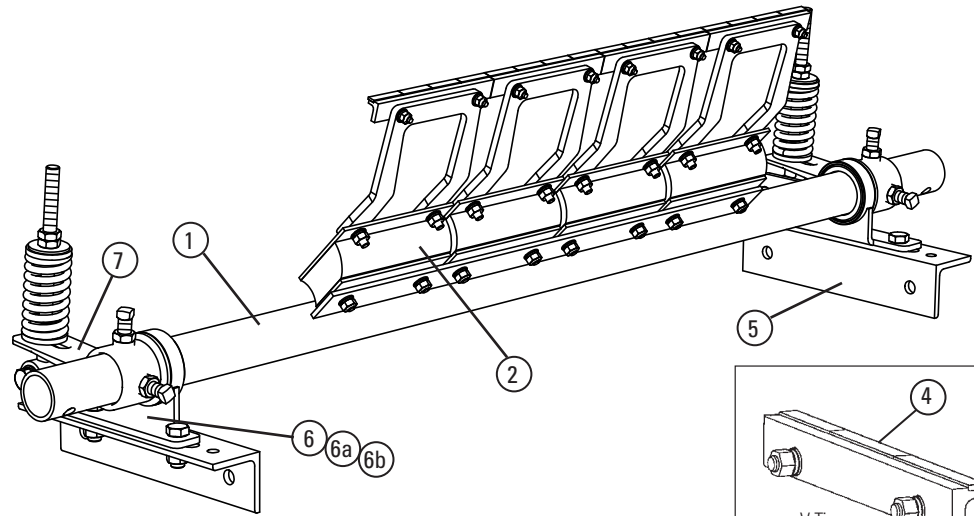
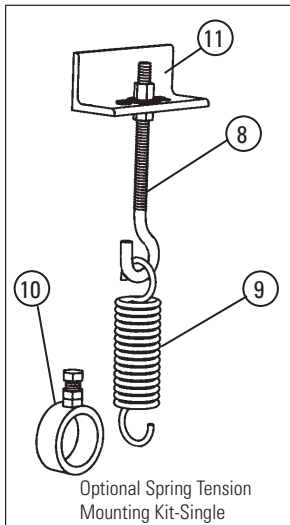

Replacement Parts*

REF	DESCRIPTION	BELT WIDTH	POLE LENGTH (MM)	POWDER COATED			STAINLESS STEEL	
				ORDERING NUMBER	ITEM CODE	WT. KG.	ORDERING NUMBER	ITEM CODE
1	H-Type® Pole Standard- 60 mm Pole Diameter	450	1250	HP450	73027	10.0	HP450-S/S	75373
		600	1350	HP600	73029	11.0	HP600-S/S	75374
		750	1500	HP750	73031	13.0	HP750-S/S	75375
		900	1650	HP900	73033	15.0	HP900-S/S	75376
		1050	1800	HP1050	73035	20.0	HP1050-S/S	75377
	H-Type Pole Standard- 73 mm Pole Diameter	1200	1950	HP1200	73037	22.0	HP1200-S/S	75378
		1500	2350	HP1500	73066	24.0	HP1500-S/S	75379
		1600	2450	HP1600	73739	27.0	HP1600-S/S	75380
		H-Type Pole Heavy-Duty- 73 mm Pole Diameter Braced and Gussetted	1800	2650	HPHD1800	74601	34.0	HPHD1800-S/S
2000	2950		HPHD2000	74547	39.0	HPHD2000-S/S	A1783	
2400	3250		HPHD2400	74548	43.5	HPHD2400-S/S	A2590	

2	Cushion	HSA	73486	2.0	HVC-S/S	73494
	Heavy-Duty Cushion	SHSD	73483	2.0	SHSD-S/S	76467
-	H Polyshield (Not shown)	HPS8	73050	1.0	HSTSS	61173
4	V-Tip	HSA200	73489	0.5	HVT8-S/S	75419
					HVPT-S/S	73631

SIDE MOUNTING ASSEMBLY COMPONENTS- TO SUIT 60 mm

5	H Mounting Bracket	HDMRK	74582	2.0	HDMRK-S/S	76245
6	H Bearing	HBRK	73068	1.5	HBRK-S/S	75422
6a	H Poly Bush 60mm	UNB60	61369	0.1		
6b	H Poly Bush 73mm	UNB73	A2671	0.1		
7	H Adjusting Arm	HARK	73069	1.5	HARK-S/S	75423
8	J-Bolt	STJK	74417	1.0		
9	Tension Spring	STTS	74419	1.0		
10	Spring Tensioner Collar	STCK	74506	1.0	STCK-S/S	75425
11	Spring Tensioner J-Bolt Mount	STJM	74775	1.0	STJM-S/S	75426
-	Spring Tension Kit-Dual (incl. STJK, STTS, STCK, STJM - 2 ea.)	STKD	74504	5.0	STKD-S/S	75427
-	H Mounting Kit- Dual (incl. HDMRK, HBRK, HARK - 2 ea.)	HMK	73054	11.0	HMK-S/S	75424
-	Black Compression Spring Side Assembly 60mm	HCSTK-60-B	62747	11.0	HCSTK-60-B-S/S	62748
-	Gold Compression Spring Side Assembly 60mm	HCSTK-60-G	62741	11.0	HCSTK-60-G-S/S	62742

SIDE MOUNTING ASSEMBLY COMPONENTS- TO SUIT 73 mm

5	H Mounting Bracket	HDMRK	74582	3.0	HDMRK-S/S	76245
6	H Bearing	HBRKX	74549	2.0	HBRKX-S/S	76246
7	H Adjusting Arm	HDARK	74550	2.0	HDARK-S/S	76247
8	J-Bolt	STJK	74417	1.0		
9	Tension Spring	UTS	74420	1.0		
10	Spring Tensioner Collar	HDCK	74490	1.0	HDSTCK-S/S	A2189
11	Spring Tensioner J-Bolt Mount	STJM	74775	1.0	STJM-S/S	75426
-	Spring Tension Kit-Dual (incl. STJK, UTS, HDCK, STJM - 2 ea.)	HDSTKD	A2518	5.0	HDSTKD-S/S	A2519
-	H Mounting Kit- Dual (incl. HDMRK, HBRKX, HDARK - 2 ea.)	HDMK	74551	14.0	HDMK-S/S	76248
-	Black Compression Spring Side Assembly (to 1600 belt width max)	H73CSK-B	62749	17.8	H73CSK-B-S/S	62750
-	Gold Compression Spring Side Assembly (to 2400 belt width max)	H73CSK-G	62743	17.8	H73CSK-G-S/S	62744

*For P-CST replacement parts, please refer to page 43.

Replacement Parts List

H-Type with PCST Optional Tensioners

ATV Replacement Parts

REF	DESCRIPTION	ORDERING NUMBER	ITEM CODE	WT. KG.
1	Air Primary Mount Bracket Stainless Steel	AIR HDMRK S/S	62034	2.0
2	Bearing Repair Kit 60mm	HBRK-S/S-60	75422	1.5
	Bearing Repair Kit 73mm	HBRK-S/S-73	76246	2.0
3	Air Primary Adjust Arm 60mm	AIR HARK-S/S-60	62035	1.5
	Air Primary Adjust Arm 73mm	AIR HARK-S/S-73	64175	2.0
4	Air Bag Primary	AIR BAG P	62036	0.5
5	Hex Nut	HEX NUT	G1211	0.1
6	Air Line Adapter	ATV-NIP	62037	0.1
-	Primary Ait Tension Kit 60mm (incl. 2 ea items AIR HDMRK S/S, HBRK-S/S-60, AIR HARK-S/S-60, AIR BAG P, HEX NUT, ATV-NIP)	HATDMK-S/S	63861	11.0
-	Primary Ait Tension Kit 73mm (incl. 2 ea items AIR HDMRK S/S, HBRK-S/S-73, AIR HARK-S/S-73, AIR BAG P, HEX NUT, ATV-NIP)	HDATDMK-S/S	63862	14.0

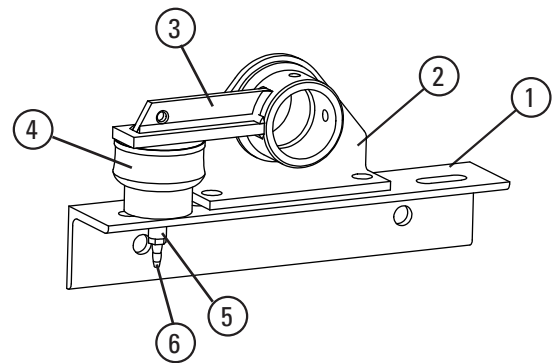

P-CST Replacement Parts - Mild Steel PCST 60mm

REF	DESCRIPTION	ORDERING NUMBER	ITEM CODE	WT. KG.
1	H Bearing Bush 60mm	HCSBB-60	62513	0.1
2	Acme Pivot Rod Kit	ACME-PRK	62496	0.6
3	Acme Nut	ACME-N	62591	0.1
4a	Spring Black (To 1600 Belt Width Max)	STS-B	75844	0.5
4b	Spring Gold (To 2400 Belt Width Max)	STS-G	78142	0.5
5	Spring Bush Kit (Black/Gold)	HCSSB-B/G	62589	0.1
6	Torque Arm Kit 60mm	ESTAK-EST	76406	1.6
-	Black 60mm Compression Spring Side Assembly (to 1600 belt width max)	H60CSK-B	62747	11.0
-	Gold 60mm Compression Spring Side Assembly (to 2400 belt width max)	H60CSK-G	62741	11.0

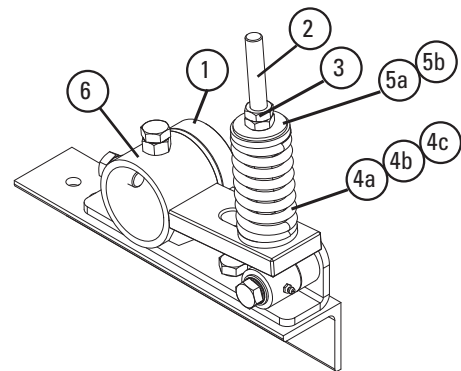

P-CST Replacement Parts - Mild Steel PCST 73mm

REF	DESCRIPTION	ORDERING NUMBER	ITEM CODE	WT. KG.
1	H Bearing Bush 73mm	HCSBB-73	62514	2.0
2	Acme Pivot Rod Kit	ACME-PRK	62496	0.6
3	Acme Nut	ACME-N	62591	0.1
4a	Spring Black (To 1600 Belt Width Max)	STS-B	75844	0.5
4b	Spring Gold (To 2400 Belt Width Max)	STS-G	78142	0.5
4c	Spring Silver (Above 2400 Belt Width)	PSTS-S	75899	0.5
5a	Spring Bush (Black/Gold)	HCSSB-B/G	62589	0.1
5b	Spring Bush (Silver)	HCSSB-S	62590	0.2
6	Torque Arm Kit 73mm	HCSTAK	62494	1.6
-	Black 73mm Compression Spring Side Assembly (to 1600 belt width max)	H73CSK-B	62749	17.8
-	Gold 73mm Compression Spring Side Assembly (to 2400 belt width max)	H73CSK-G	62743	17.8
-	Silver 73mm Compression Spring Side Assembly (above 2400)	H73CSK-S	62745	18.0

P-CST Replacement Parts - Stainless Steel PCST 73mm

REF	DESCRIPTION	ORDERING NUMBER	ITEM CODE	WT. KG.
1	H Bearing Bush 73mm	HCSBB-73	62514	2.0
2	Acme Pivot Rod Kit	ACME-PRK	62496	0.6
3	Acme Nut	ACME-N	62591	0.1
4a	Spring Black (To 1600 Belt Width Max)	STS-B-S/S	77632	0.5
4b	Spring Gold (To 2400 Belt Width Max)	STS-G-S/S	79057	0.5
4c	Spring Silver (Above 2400 Belt Width)	PSTS-S-S/S	79056	0.5
5a	Spring Bush (Black/Gold)	HCSSB-B/G	62589	0.1
5b	Spring Bush (Silver)	HCSSB-S	62590	0.2
6	Torque Arm Kit 73mm	HCSTAK-S/S	62495	1.6
-	Black 73mm Compression Spring Side Assembly (to 1600 belt width max)	H73CSK-B-S/S	62750	18.3
-	Gold 73mm Compression Spring Side Assembly (to 2400 belt width max)	H73CSK-G-S/S	62744	18.3
-	Silver 73mm Compression Spring Side Assembly (above 2400 belt width max)	H73CSK-S-S/S	62746	18.4

P-CST Replacement Parts - Stainless Steel PCST 60mm

REF	DESCRIPTION	ORDERING NUMBER	ITEM CODE	WT. KG.
1	H Bearing Bush 60mm	HCSBB-60	62513	0.1
2	Acme Pivot Rod Kit	ACME-PRK	62496	0.6
3	Acme Nut	ACME-N	62591	0.1
4a	Spring Black (To 1600 Belt Width Max)	STS-B-S/S	77632	0.5
4b	Spring Gold (To 2400 Belt Width Max)	STS-G-S/S	79057	0.5
5	Spring Bush Kit (Black/Gold)	HCSSB-B/G	62589	0.1
6	Torque Arm Kit 60mm	ESTAK-EST-S/S	78849	1.6
-	Black 60mm Compression Spring Side Assembly (to 1600 belt width max)	H60CSK-B-S/S	62748	17.3
-	Gold 60mm Compression Spring Side Assembly (to 2400 belt width max)	H60CSK-G-S/S	62742	17.3

Stock items (non-shaded) refer to (*) for specific lead time, if not specified, standard lead time applies.

Non-stock items (shaded) please contact Flexco for dispatch options and lead times.

Product Ordering Information

H-Type ESAC (Mild Steel) HD Primary Cleaner with Enhanced Service Advantage Cartridge™

Powder Coated H-Type® ESAC with V-Tips

TIP WIDTH	ARM SIZE	ORDERING NUMBER	ITEM CODE	Wght. KG.
Single Cartridge				
600	CS	HV-600-SAC-CS	62515	74.2
	CM	HV-600-SAC-CM	62516	74.9
	CL	HV-600-SAC-CL	62517	75.3
800	CS	HV-800-SAC-CS	62518	86.5
	CM	HV-800-SAC-CM	62519	87.5
	CL	HV-800-SAC-CL	62520	88.1
1000	CS	HV-1000-SAC-CS	62521	94.9
	CM	HV-1000-SAC-CM	62522	96.2
	CL	HV-1000-SAC-CL	62523	96.9
1200	CS	HV-1200-SAC-CS	62524	103.3
	CM	HV-1200-SAC-CM	62525	104.7
	CL	HV-1200-SAC-CL	62526	105.6
1400	CS	HV-1400-SAC-CS	62527	115.9
	CM	HV-1400-SAC-CM	62528	117.5
	CL	HV-1400-SAC-CL	62529	118.6
1600	CM	HV-1600-SAC-CM	62530	130.0
	CL	HV-1600-SAC-CL	62531	131.3
	CLL	HV-1600-SAC-CLL	62532	135.2
1800	CM	HV-1800-SAC-CM	62533	137.2
	CL	HV-1800-SAC-CL	62534	138.5
	CLL	HV-1800-SAC-CLL	62535	142.8
Dual Cartridge				
1200	CS	HV-1200-2SAC-CS	62557	128.7
	CM	HV-1200-2SAC-CM	62558	130.3
	CL	HV-1200-2SAC-CL	62559	131.2
	CLL	HV-1200-2SAC-CLL	62560	134.1
1400	CS	HV-1400-2SAC-CS	62561	137.4
	CM	HV-1400-2SAC-CM	62562	139.0
	CL	HV-1400-2SAC-CL	62563	140.1
	CLL	HV-1400-2SAC-CLL	62564	143.4
1600	CM	HV-1600-2SAC-CM	62565	147.9
	CL	HV-1600-2SAC-CL	62566	149.1
	CLL	HV-1600-2SAC-CLL	62567	152.9
1800	CM	HV-1800-2SAC-CM	62568	159.5
	CL	HV-1800-2SAC-CL	62569	160.9
	CLL	HV-1800-2SAC-CLL	62570	163.8
2000	CM	HV-2000-2SAC-CM	62571	169.2
	CL	HV-2000-2SAC-CL	62572	170.7
	CLL	HV-2000-2SAC-CLL	62573	174.0
2200	CM	HV-2200-2SAC-CM	62574	182.4
	CL	HV-2200-2SAC-CL	62575	184.1
	CLL	HV-2200-2SAC-CLL	62576	187.7
2400	CM	HV-2400-2SAC-CM	62577	187.5
	CL	HV-2400-2SAC-CL	62578	189.3
	CLL	HV-2400-2SAC-CLL	62579	193.3
2600	CM	HV-2600-2SAC-CM	62580	211.2
	CL	HV-2600-2SAC-CL	62581	213.2
	CLL	HV-2600-2SAC-CLL	62582	217.4
2800	CM	HV-2800-2SAC-CM	62583	220.9
	CL	HV-2800-2SAC-CL	62584	223.0
	CLL	HV-2800-2SAC-CLL	62585	227.7
3000	CM	HV-3000-2SAC-CM	62586	230.0
	CL	HV-3000-2SAC-CL	62587	232.3
	CLL	HV-3000-2SAC-CLL	62588	237.2

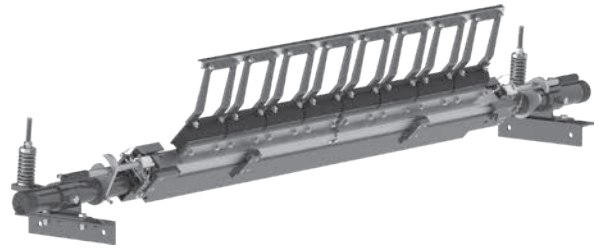

H-Type ESAC Dual HD Primary Cleaner

Replacement V-Tips

ORDERING NUMBER	ITEM CODE	WT. KG.
HSA200	73489	0.5

Replacement Suspension Arms

SIZE	ORDERING NUMBER	ITEM CODE	WT. KG.
CS	HSA8CS	62505	1.1
CM	HSA8CM	62506	1.3
CL	HSA8CL	62507	1.5
CLL	HSA8CLL	62508	1.7

Suspension Arm Size

HEAD PULLEY DIAMETER + BELT & LAGGING mm	SUSPENSION ARM SIZE
500-799	CS
800-999	CM
1000-1199	CL
1200-1700	CLL

Over 1700mm - contact Flexco

Tips required per cleaner size

BELT WIDTH mm	BELT COVERAGE mm	V-TIPS REQUIRED
600	600	3
800	800	4
1000	1000	5
1200	1200	6
1400	1400	7
1600	1600	8
1800	1800	9
2000	2000	10
2200	2200	11
2400	2400	12
2600	2600	13
2800	2800	14
3000	3000	15

U.S. Patent No. 7,987,966; 8,757,360; 8,312,986;
8,640,856; 9,090,405; 9,085,419

Stock items (non-shaded) refer to (*) for specific lead time, if not specified, standard lead time applies.

Non-stock items (shaded) please contact Flexco for dispatch options and lead times.

Product Ordering Information

H-Type ESAC (Mild Steel) HD Primary Cleaner with Enhanced Service Advantage Cartridge™

H-Type ESAC Mild Steel Replacement Cartridge Kits with V-Tips

TIP WIDTH	ARM SIZE	ORDERING NUMBER	ITEM CODE	Wght. KG.
Single Cartridge Kits				
600	CS	H-CARK-600-CS	62536	23.2
	CM	H-CARK-600-CM	62537	24.0
	CL	H-CARK-600-CL	62538	24.5
800	CS	H-CARK-800-CS	62539	30.3
	CM	H-CARK-800-CM	62540	31.3
	CL	H-CARK-800-CL	62541	31.9
1000	CS	H-CARK-1000-CS	62542	36.1
	CM	H-CARK-1000-CM	62543	37.4
	CL	H-CARK-1000-CL	62544	38.2
1200	CS	H-CARK-1200-CS	62545	41.4
	CM	H-CARK-1200-CM	62546	43.3
	CL	H-CARK-1200-CL	62547	44.2
1400	CS	H-CARK-1400-CS	62548	49.0
	CM	H-CARK-1400-CM	62549	50.8
	CL	H-CARK-1400-CL	62550	51.9
1600	CM	H-CARK-1600-CS	62551	58.1
	CL	H-CARK-1600-CM	62552	59.3
	CLL	H-CARK-1600-CL	62553	63.1
1800	CM	H-CARK-1800-CS	62554	66.2
	CL	H-CARK-1800-CM	62555	67.6
	CLL	H-CARK-1800-CL	62556	71.9
Dual Cartridge Kits				
1200	CS	H-CARK2-1200-CS	62599	46.2
	CM	H-CARK2-1200-CM	62600	47.8
	CL	H-CARK2-1200-CL	62601	48.7
	CLL	H-CARK2-1200-CLL	62602	51.6
1400	CS	H-CARK2-1400-CS	62603	51.8
	CM	H-CARK2-1400-CM	62604	53.6
	CL	H-CARK2-1400-CL	62605	54.6
	CLL	H-CARK2-1400-CLL	62606	58.0
1600	CM	H-CARK2-1600-CM	62607	59.4
	CL	H-CARK2-1600-CL	62608	60.6
	CLL	H-CARK2-1600-CLL	62609	64.4
1800	CM	H-CARK2-1800-CM	62610	68.1
	CL	H-CARK2-1800-CL	62611	69.4
	CLL	H-CARK2-1800-CLL	62612	73.8
2000	CM	H-CARK2-2000-CM	62613	74.8
	CL	H-CARK2-2000-CL	62614	76.3
	CLL	H-CARK2-2000-CLL	62615	81.1
2200	CM	H-CARK2-2200-CM	62616	82.1
	CL	H-CARK2-2200-CL	62617	83.7
	CLL	H-CARK2-2200-CLL	62618	89.0
2400	CM	H-CARK2-2400-CM	62619	87.1
	CL	H-CARK2-2400-CL	62620	88.9
	CLL	H-CARK2-2400-CLL	62621	94.7
2600	CM	H-CARK2-2600-CM	62622	95.7
	CL	H-CARK2-2600-CL	62623	97.7
	CLL	H-CARK2-2600-CLL	62624	103.9
2800	CM	H-CARK2-2800-CM	62625	102.2
	CL	H-CARK2-2800-CL	62626	104.3
	CLL	H-CARK2-2800-CLL	62627	111.0
3000	CM	H-CARK2-3000-CM	62628	107.7
	CL	H-CARK2-3000-CL	62629	110.0
	CLL	H-CARK2-3000-CLL	62630	117.2

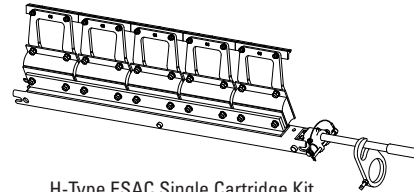

H-Type ESAC Single Cartridge Kit

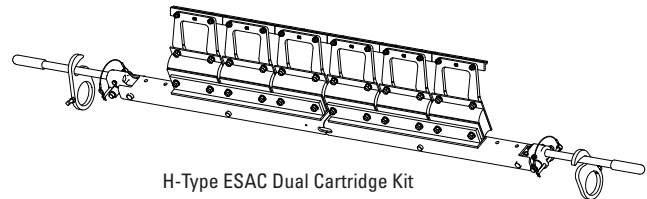

H-Type ESAC Dual Cartridge Kit

U.S. Patent No. 7,987,966; 8,757,360; 8,312,986;
8,640,856; 9,090,405; 9,085,419

Stock items (non-shaded) refer to (*) for specific lead time, if not specified, standard lead time applies.

Non-stock items (shaded) please contact Flexco for dispatch options and lead times.

Product Ordering Information

H-Type ESAC (Stainless Steel) HD Primary Cleaner with Enhanced Service Advantage Cartridge™

Stainless Steel H-Type® ESAC with V-Tips

TIP WIDTH	ARM SIZE	ORDERING NUMBER	ITEM CODE	Wght. KG.
Single Cartridge				
600	CS	HV-600-SAC-CS-S/S	62631	74.2
	CM	HV-600-SAC-CM-S/S	62632	74.9
	CL	HV-600-SAC-CL-S/S	62633	75.3
800	CS	HV-800-SAC-CS-S/S	62634	86.5
	CM	HV-800-SAC-CM-S/S	62635	87.5
	CL	HV-800-SAC-CL-S/S	62636	88.1
1000	CS	HV-1000-SAC-CS-S/S	62637	94.9
	CM	HV-1000-SAC-CM-S/S	62638	96.2
	CL	HV-1000-SAC-CL-S/S	62639	96.9
1200	CS	HV-1200-SAC-CS-S/S	62640	103.3
	CM	HV-1200-SAC-CM-S/S	62641	104.7
	CL	HV-1200-SAC-CL-S/S	62642	105.6
1400	CS	HV-1400-SAC-CS-S/S	62643	115.9
	CM	HV-1400-SAC-CM-S/S	62644	117.5
	CL	HV-1400-SAC-CL-S/S	62645	118.6
1600	CM	HV-1600-SAC-CM-S/S	62646	130.0
	CL	HV-1600-SAC-CL-S/S	62647	131.3
	CLL	HV-1600-SAC-CLL-S/S	62648	135.2
1800	CM	HV-1800-SAC-CM-S/S	62649	137.2
	CL	HV-1800-SAC-CL-S/S	62650	138.5
	CLL	HV-1800-SAC-CLL-S/S	62651	142.8
Dual Cartridge				
1200	CS	HV-1200-2SAC-CS-S/S	62673	128.7
	CM	HV-1200-2SAC-CM-S/S	62674	130.3
	CL	HV-1200-2SAC-CL-S/S	62675	131.2
	CLL	HV-1200-2SAC-CLL-S/S	62676	134.1
1400	CS	HV-1400-2SAC-CS-S/S	62677	137.4
	CM	HV-1400-2SAC-CM-S/S	62678	139.0
	CL	HV-1400-2SAC-CL-S/S	62679	140.1
	CLL	HV-1400-2SAC-CLL-S/S	62680	143.4
1600	CM	HV-1600-2SAC-CM-S/S	62681	147.9
	CL	HV-1600-2SAC-CL-S/S	62582	160.9
	CLL	HV-1600-2SAC-CLL-S/S	62683	152.9
1800	CM	HV-1800-2SAC-CM-S/S	62684	159.5
	CL	HV-1800-2SAC-CL-S/S	62685	160.9
	CLL	HV-1800-2SAC-CLL-S/S	62686	163.8
2000	CM	HV-2000-2SAC-CM-S/S	62687	169.2
	CL	HV-2000-2SAC-CL-S/S	62688	170.7
	CLL	HV-2000-2SAC-CLL-S/S	62689	174.0
2200	CM	HV-2200-2SAC-CM-S/S	62690	182.4
	CL	HV-2200-2SAC-CL-S/S	62691	184.1
	CLL	HV-2200-2SAC-CLL-S/S	62692	187.7
2400	CM	HV-2400-2SAC-CM-S/S	62693	187.5
	CL	HV-2400-2SAC-CL-S/S	62694	189.3
	CLL	HV-2400-2SAC-CLL-S/S	62695	193.3
2600	CM	HV-2600-2SAC-CM-S/S	62696	211.2
	CL	HV-2600-2SAC-CL-S/S	62697	213.2
	CLL	HV-2600-2SAC-CLL-S/S	62698	217.4
2800	CM	HV-2800-2SAC-CM-S/S	62699	220.9
	CL	HV-2800-2SAC-CL-S/S	62700	223.0
	CLL	HV-2800-2SAC-CLL-S/S	62701	227.7
3000	CM	HV-3000-2SAC-CM-S/S	62702	230.0
	CL	HV-3000-2SAC-CL-S/S	62703	232.3
	CLL	HV-3000-2SAC-CLL-S/S	62704	237.2

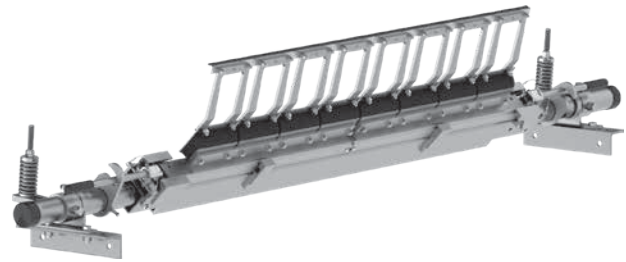

Stainless Steel H-Type ESAC Dual HD Primary Cleaner

Replacement V-Tips

ORDERING NUMBER	ITEM CODE	WT. KG.
HVT8-S/S	75419	0.9
HVPT-S/S	73631	1.2

Replacement Suspension Arms SS

SIZE	ORDERING NUMBER	ITEM CODE	WT. KG.
CS	HSA8CS-S/S	62509	1.1
CM	HSA8CM-S/S	62510	1.3
CL	HSA8CL-S/S	62511	1.5
CLL	HSA8CLL-S/S	62512	1.7

Suspension Arm Size

HEAD PULLEY DIAMETER + BELT & LAGGING mm	SUSPENSION ARM SIZE
500-799	CS
800-999	CM
1000-1199	CL
1200-1700	CLL

Over 1700mm - contact Flexco

Tips required per cleaner size

BELT WIDTH mm	BELT COVERAGE mm	V-TIPS REQUIRED
600	600	3
800	800	4
1000	1000	5
1200	1200	6
1400	1400	7
1600	1600	8
1800	1800	9
2000	2000	10
2200	2200	11
2400	2400	12
2600	2600	13
2800	2800	14
3000	3000	15

U.S. Patent No. 7,987,966; 8,757,360; 8,312,986;
8,640,856; 9,090,405; 9,085,419

Stock items (non-shaded) refer to (*) for specific lead time, if not specified, standard lead time applies.

Non-stock items (shaded) please contact Flexco for dispatch options and lead times.

Product Ordering Information

H-Type ESAC (Stainless Steel) HD Primary Cleaner with Enhanced Service Advantage Cartridge™

H-Type ESAC Stainless Steel Replacement Cartridge Kits with V-Tips

TIP WIDTH	ARM SIZE	ORDERING NUMBER	ITEM CODE	Wght. KG.
Single Cartridge Kits				
600	CS	H CARK-600-CS-S/S	62652	23.2
	CM	H CARK-600-CM-S/S	62653	24.0
	CL	H CARK-600-CL-S/S	62654	24.5
800	CS	H CARK-800-CS-S/S	62655	30.3
	CM	H CARK-800-CM-S/S	62656	31.3
	CL	H CARK-800-CL-S/S	62657	31.9
1000	CS	H CARK-1000-CS-S/S	62658	36.1
	CM	H CARK-1000-CM-S/S	62659	37.4
	CL	H CARK-1000-CL-S/S	62660	38.2
1200	CS	H CARK-1200-CS-S/S	62661	41.4
	CM	H CARK-1200-CM-S/S	62662	43.3
	CL	H CARK-1200-CL-S/S	62663	44.2
1400	CS	H CARK-1400-CS-S/S	62664	49.0
	CM	H CARK-1400-CM-S/S	62665	50.8
	CL	H CARK-1400-CL-S/S	62666	51.9
1600	CM	H CARK-1600-CS-S/S	62667	58.1
	CL	H CARK-1600-CM-S/S	62668	59.3
	CLL	H CARK-1600-CL-S/S	62669	63.1
1800	CM	H CARK-1800-CS-S/S	62670	66.2
	CL	H CARK-1800-CM-S/S	62671	67.6
	CLL	H CARK-1800-CL-S/S	62672	71.9
Dual Cartridge Kits				
1200	CS	H-CARK2-1200-CS-S/S	62705	46.2
	CM	H-CARK2-1200-CM-S/S	62706	47.8
	CL	H-CARK2-1200-CL-S/S	62707	48.7
	CLL	H-CARK2-1200-CLL-S/S	62708	51.6
1400	CS	H-CARK2-1400-CS-S/S	62709	51.8
	CM	H-CARK2-1400-CM-S/S	62710	53.6
	CL	H-CARK2-1400-CL-S/S	62711	54.6
	CLL	H-CARK2-1400-CLL-S/S	62712	58.0
1600	CM	H-CARK2-1600-CM-S/S	62713	59.4
	CL	H-CARK2-1600-CL-S/S	62714	60.6
	CLL	H-CARK2-1600-CLL-S/S	62715	64.4
1800	CM	H-CARK2-1800-CM-S/S	62716	68.1
	CL	H-CARK2-1800-CL-S/S	62717	69.4
	CLL	H-CARK2-1800-CLL-S/S	62718	73.8
2000	CM	H-CARK2-2000-CM-S/S	62719	74.8
	CL	H-CARK2-2000-CL-S/S	62720	76.3
	CLL	H-CARK2-2000-CLL-S/S	62721	81.1
2200	CM	H-CARK2-2200-CM-S/S	62722	82.1
	CL	H-CARK2-2200-CL-S/S	62723	83.7
	CLL	H-CARK2-2200-CLL-S/S	62724	89.0
2400	CM	H-CARK2-2400-CM-S/S	62725	87.1
	CL	H-CARK2-2400-CL-S/S	62726	88.9
	CLL	H-CARK2-2400-CLL-S/S	62727	94.7
2600	CM	H-CARK2-2600-CM-S/S	62728	95.7
	CL	H-CARK2-2600-CL-S/S	62729	97.7
	CLL	H-CARK2-2600-CLL-S/S	62730	103.9
2800	CM	H-CARK2-2800-CM-S/S	62731	102.2
	CL	H-CARK2-2800-CL-S/S	62732	104.3
	CLL	H-CARK2-2800-CLL-S/S	62733	111.0
3000	CM	H-CARK2-3000-CM-S/S	62734	107.7
	CL	H-CARK2-3000-CL-S/S	62735	110.0
	CLL	H-CARK2-3000-CLL-S/S	62736	117.2

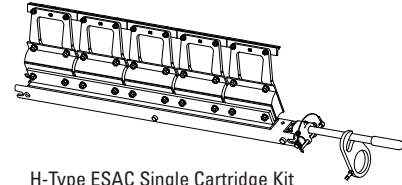

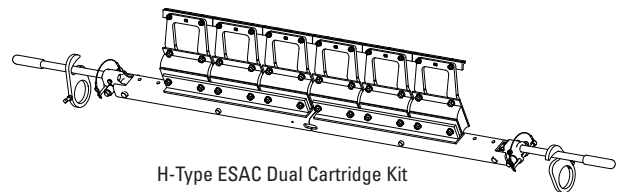

H-Type ESAC Single Cartridge Kit



H-Type ESAC Dual Cartridge Kit

U.S. Patent No. 7,987,966; 8,757,360; 8,312,986;
8,640,856; 9,090,405; 9,085,419

 Stock items (non-shaded) refer to (*) for specific lead time, if not specified, standard lead time applies.

 Non-stock items (shaded) please contact Flexco for dispatch options and lead times.

Replacement Parts List

H-Type ESAC Single HD Primary Cleaner with Enhanced Service Advantage Cartridge™

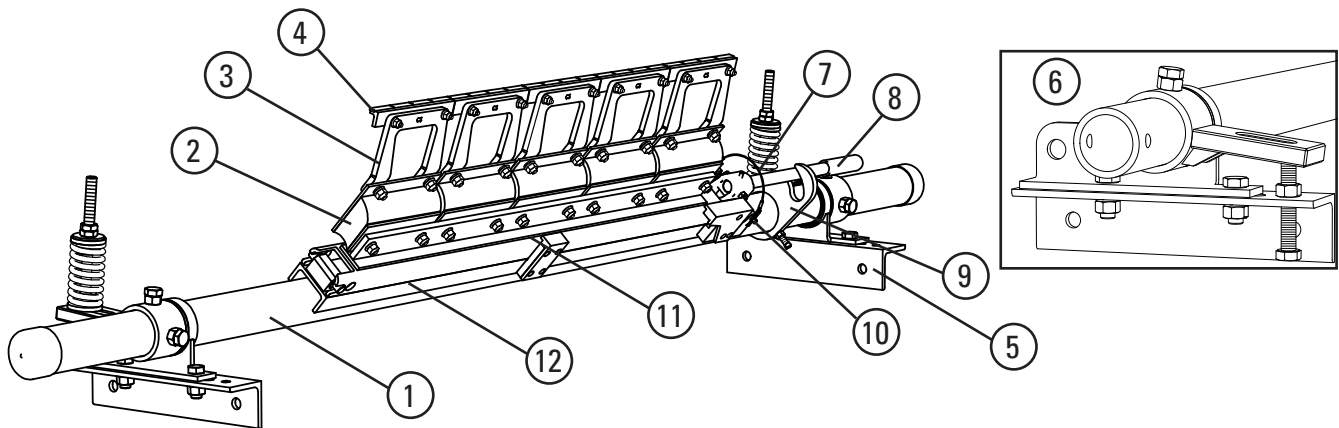

REPLACEMENT PARTS

REF	DESCRIPTION	MILD STEEL			STAINLESS STEEL		
		ORDERING NUMBER	ITEM CODE	WT. KG.	ORDERING NUMBER	ITEM CODE	WT. KG.
1	H-Type Single ESAC Cartridge Pole	HCP-600	62751	30.5	HCP-600-S/S	62757	31.4
		HCP-800	62752	35.6	HCP-800-S/S	62758	36.7
		HCP-1000	62753	38.1	HCP-1000-S/S	62759	39.3
		HCP-1200	62754	40.7	HCP-1200-S/S	62760	42
		HCP-1400	62755	45.9	HCP-1400-S/S	62761	47.3
		HCP-1800	62756	51.0	HCP-1800-S/S	62762	52.6
2	HD Cushion	HSHD	73483	2.0	HSHD-S/S	76467	2
3	Suspension Arm	HSA8CS	62505	0.9	HSA8CS-S/S	62509	1
		HSA8CM	62506	1.1	HSA8CM-S/S	62510	1.2
		HSA8CL	62507	1.3	HSA8CL-S/S	62511	1.3
		HSA8CLL	62508	1.8	HSA8CLL-S/S	62512	1.8
4	HV Tips	HSA200	73489	0.5	HVT8-S/S	75419	0.6
	HVPT Tips	-	-	-	HVPT-S/S	73631	0.6
5	Black Compression Spring Side Assembly (to 1600 belt width max)	H73CSK-B	62749	17.8	H73CSK-B-S/S	62750	18.3
	Gold Compression Spring Side Assembly (to 2400 belt width max)	H73CSK-G	62743	17.8	H73CSK-G-S/S	62744	18.3
6	Bolt Tension Side Assembly	H73BTK	63079	15.1	H73BTK-S/S	63080	15.6
7	SAC Removal Knuckle	SACRKN	77882	1.5			
8	SAC Removal Handle	SACRH	77883	1.4			
9	SAC Handle Lock Plate	SACRHL	77884	0.8			
10	Knuckle Retainer Pin	SACKRP	77885	0.1			
REF	DESCRIPTION	TIP WIDTH	ORDERING NUMBER	ITEM CODE	WT. KG.		
11	H-Type Cartridge Adapter Plate	600	H-SAC-AP-600	62452	3.5		
		800	H-SAC-AP-800	62453	4.8		
		1000	H-SAC-AP-1000	62454	6.0		
		1200	H-SAC-AP-1200	62455	7.3		
		1400	H-SAC-AP-1400	62456	8.5		
		1600	H-SAC-AP-1600	62457	9.8		
12	SAC Replacement Single Cartridge	600	CART-24/600-S/S	78576	4.5		
		800	CART-36/900-S/S	78578	6.7		
		1000	CART-42/1050-S/S	78579	7.8		
		1200	CART2-48/1200-S/S	78580	8.9		
		1400	CART-60/1500-S/S	78582	11.3		
		1600	CART-72/1800-S/S	78583	13.5		
		1800					

HV/HVP Single SAC Black Spring Length Chart (for optimal blade tensioning)

Belt Width	CS	CM	CL	CLL
600	111	110	109	107
800	109	107	107	104
1000	106	105	104	100
1200	104	102	101	97
1400	102	100	98	93
1600	100	97	96	90
1800	97	95	93	-

HV/HVP Single SAC Gold Spring Length Chart (for optimal blade tensioning)

Belt Width	CS	CM	CL	CLL
600	113	113	112	111
800	112	111	111	109
1000	111	110	109	107
1200	109	108	107	105
1400	108	106	106	102
1600	106	105	104	100
1800	105	103	102	98

HV/HVP Dual SAC Gold Spring Length Chart (for optimal blade tensioning)

Belt Width	CS	CM	CL	CLL
1200	109	108	108	105
1400	108	107	106	103
1600	107	105	104	101
1800	105	104	103	99
2000	104	102	101	96
2200	103	101	99	94

HV/HVP Dual SAC Silver Spring Length Chart (for optimal blade tensioning)

Belt Width	CS	CM	CL	CLL
2200	159	158	157	154
2400	158	157	156	153
2600	157	156	155	151
2800	157	155	154	150
3000	156	154	153	149

U.S. Patent No. 7,987,966; 8,757,360; 8,312,986;
8,640,856; 9,090,405; 9,085,419

Stock items (non-shaded) refer to (*) for specific lead time, if not specified, standard lead time applies.
Non-stock items (shaded) please contact Flexco for dispatch options and lead times.

Replacement Parts List

H-Type ESAC Dual HD Primary Cleaner with Enhanced Service Advantage Cartridge™

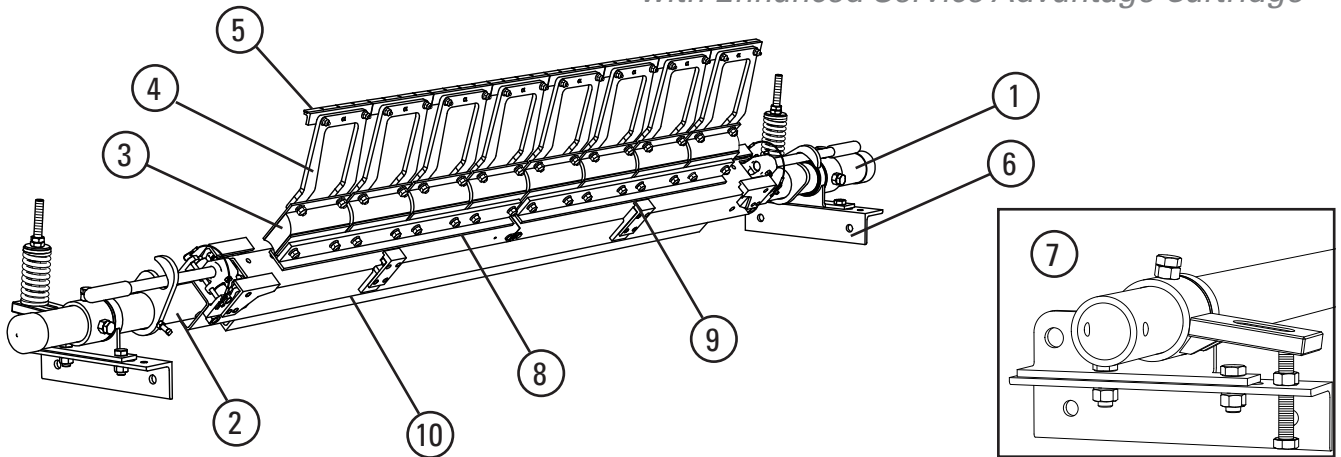

REPLACEMENT PARTS

REF	DESCRIPTION	MILD STEEL			STAINLESS STEEL			
		ORDERING NUMBER	ITEM CODE	WT. KG.	ORDERING NUMBER	ITEM CODE	WT. KG.	
1	H-Type Dual ESAC Centre Pole	H2CP-1200	62763	39.7	H2CP-1200-S/S	62801	39.7	
		H2CP-1400	62764	42.6	H2CP-1400-S/S	62802	42.6	
		H2CP-1600	62765	45.7	H2CP-1600-S/S	62803	45.7	
		H2CP-1800	62766	48.6	H2CP-1800-S/S	62804	48.6	
		H2CP-2000	62767	51.6	H2CP-2000-S/S	62805	51.6	
		H2CP-2400	62768	57.6	H2CP-2400-S/S	62806	57.6	
		H2CP-2600	62769	71.0	H2CP-2600-S/S	62807	71.0	
		H2CP-2800	62770	74.3	H2CP-2800-S/S	62808	74.3	
	H2CP-3000	62771	77.8	H2CP-3000-S/S	62809	77.8		
2	Extender Pole	MHP-EP	76392	24.5	MHP-EP-S/S	77599	24.5	
3	HD Cushion	HSHD	73483	2.0	HSHD-S/S	76467	2.0	
4	Suspension Arm	HSA8CS	62505	0.9	HSA8CS-S/S	62509	1.0	
		HSA8CM	62506	1.1	HSA8CM-S/S	62510	1.2	
		HSA8CL	62507	1.3	HSA8CL-S/S	62511	1.3	
		HSA8CLL	62508	1.8	HSA8CLL-S/S	62512	1.8	
5	HV Tips	HSA200	73489	0.5	HVT8-S/S	75419	0.6	
	HVPT Tips	-	-	-	HVPT-S/S	73631	0.6	
6	Black Compression Spring Side Assembly (to 1600 belt width max)	H73CSK-B	62749	17.8	H73CSK-B-S/S	62750	18.3	
	Gold Compression Spring Side Assembly (to 2400 belt width max)	H73CSK-G	62743	17.8	H73CSK-G-S/S	62744	18.3	
	Silver 6" Compression Spring Side Assembly (above 2400)	H73CSK-S	62745	18.0	H73CSK-S-S/S	62746	18.4	
7	Bolt Tension Side Assembly	H73BTK	63079	15.1	H73BTK-S/S	63080	15.6	
REF	DESCRIPTION	TIP WIDTH	ITEM 8 / LEFT HAND			ITEM 9 / RIGHT HAND		
			ORDERING NUMBER	ITEM CODE	WT. KG.	ORDERING NUMBER	ITEM CODE	WT. KG.
8 & 9	H-Type Cartridge Adapter Plate	1200	H-SAC-AP-600	62452	3.5	H-SAC-AP-600	62452	3.5
		1400	H-SAC-AP-800	62453	4.8	H-SAC-AP-600	62452	3.5
		1600	H-SAC-AP-800	62453	4.8	H-SAC-AP-800	62453	4.8
		1800	H-SAC-AP-1000	62454	6.0	H-SAC-AP-800	62453	4.8
		2000	H-SAC-AP-1000	62454	6.0	H-SAC-AP-1000	62454	6.0
		2200	H-SAC-AP-1200	62455	7.3	H-SAC-AP-1000	62454	6.0
		2400	H-SAC-AP-1200	62455	7.3	H-SAC-AP-1200	62455	7.3
		2600	H-SAC-AP-1400	62456	8.5	H-SAC-AP-1200	62455	7.3
		2800	H-SAC-AP-1400	62456	8.5	H-SAC-AP-1400	62456	8.5
		3000	H-SAC-AP-1600	62457	9.8	H-SAC-AP-1400	62456	8.5
REF	DESCRIPTION	TIP WIDTH	ORDERING NUMBER	ITEM CODE	WT. KG.			
10	SAC Replacement Dual Cartridge	1200	CART2-60/1500-S/S	78584	11.2			
		1400	CART2-66/1650-S/S	78634	12.3			
		1600	CART2-72/1800-S/S	78585	13.4			
		1800	CART2-78/1950-S/S	78635	14.5			
		2000	CART2-84/2100-S/S	78586	15.6			
		2200	CART2-96/2400-S/S	78587	17.8			
		2400						
		2600	CART2-114/2850-S/S	78639	23.7			
		2800	CART2-120/3000-S/S	78588	22.6			
		3000	CART2-126/3150-S/S	78640	23.7			

U.S. Patent No. 7,987,966; 8,757,360; 8,312,986; 8,640,856; 9,090,405; 9,085,419

Product Ordering Information

H-Type ESAC with Extra Life V-Tips (Mild Steel) HD Primary Cleaner with Enhanced Service Advantage Cartridge™

Powder Coated H-Type® ESAC with Extra Life V-Tips

TIP WIDTH	ARM SIZE	ORDERING NUMBER	ITEM CODE	Wght. KG.
Single Cartridge				
600	CS	HV-600-SAC-CS-EL15	63206	74.2
	CM	HV-600-SAC-CM-EL15	63207	74.9
	CL	HV-600-SAC-CL-EL15	63208	75.3
800	CS	HV-800-SAC-CS-EL15	63209	86.5
	CM	HV-800-SAC-CM-EL15	63210	87.5
	CL	HV-800-SAC-CL-EL15	63211	88.1
1000	CS	HV-1000-SAC-CS-EL15	63212	94.9
	CM	HV-1000-SAC-CM-EL15	63213	96.2
	CL	HV-1000-SAC-CL-EL15	63214	96.9
1200	CS	HV-1200-SAC-CS-EL15	63215	103.3
	CM	HV-1200-SAC-CM-EL15	63216	104.7
	CL	HV-1200-SAC-CL-EL15	63217	105.6
1400	CS	HV-1400-SAC-CS-EL15	63218	115.9
	CM	HV-1400-SAC-CM-EL15	63219	117.5
	CL	HV-1400-SAC-CL-EL15	63220	118.6
1600	CM	HV-1600-SAC-CM-EL15	63221	130.0
	CL	HV-1600-SAC-CL-EL15	63222	131.3
	CLL	HV-1600-SAC-CLL-EL15	63223	135.2
1800	CM	HV-1800-SAC-CM-EL15	63224	137.2
	CL	HV-1800-SAC-CL-EL15	63225	138.5
	CLL	HV-1800-SAC-CLL-EL15	63226	142.8
Dual Cartridge				
1200	CS	HV-1200-2SAC-CS-EL15	63421	128.7
	CM	HV-1200-2SAC-CM-EL15	63422	130.3
	CL	HV-1200-2SAC-CL-EL15	63423	131.2
	CLL	HV-1200-2SAC-CLL-EL15	63424	134.1
1400	CS	HV-1400-2SAC-CS-EL15	63425	137.4
	CM	HV-1400-2SAC-CM-EL15	63426	139.0
	CL	HV-1400-2SAC-CL-EL15	63427	140.1
	CLL	HV-1400-2SAC-CLL-EL15	63428	143.4
1600	CM	HV-1600-2SAC-CM-EL15	63429	147.9
	CL	HV-1600-2SAC-CL-EL15	63430	149.1
	CLL	HV-1600-2SAC-CLL-EL15	63431	152.9
1800	CM	HV-1800-2SAC-CM-EL15	63432	159.5
	CL	HV-1800-2SAC-CL-EL15	63433	160.9
	CLL	HV-1800-2SAC-CLL-EL15	63434	163.8
2000	CM	HV-2000-2SAC-CM-EL15	63435	169.2
	CL	HV-2000-2SAC-CL-EL15	63436	170.7
	CLL	HV-2000-2SAC-CLL-EL15	63437	174.0
2200	CM	HV-2200-2SAC-CM-EL15	63438	182.4
	CL	HV-2200-2SAC-CL-EL15	63439	184.1
	CLL	HV-2200-2SAC-CLL-EL15	63440	187.7
2400	CM	HV-2400-2SAC-CM-EL15	63441	187.5
	CL	HV-2400-2SAC-CL-EL15	63442	189.3
	CLL	HV-2400-2SAC-CLL-EL15	63443	193.3
2600	CM	HV-2600-2SAC-CM-EL15	63444	211.2
	CL	HV-2600-2SAC-CL-EL15	63445	213.2
	CLL	HV-2600-2SAC-CLL-EL15	63446	217.4
2800	CM	HV-2800-2SAC-CM-EL15	63447	220.9
	CL	HV-2800-2SAC-CL-EL15	63448	223.0
	CLL	HV-2800-2SAC-CLL-EL15	63449	227.7
3000	CM	HV-3000-2SAC-CM-EL15	63450	230.0
	CL	HV-3000-2SAC-CL-EL15	63451	232.3
	CLL	HV-3000-2SAC-CLL-EL15	63452	237.2

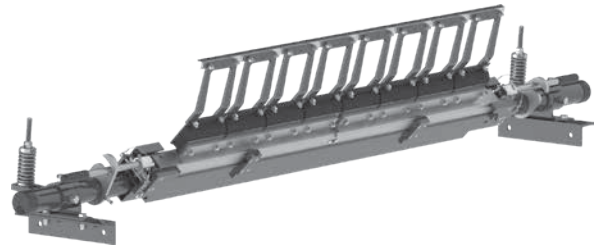

H-Type ESAC Dual HD Primary Cleaner

Replacement V-Tips

ORDERING NUMBER	ITEM CODE	WT. KG.
HSA200	73489	0.5
HSA200-EL15	76027	0.6

Replacement Suspension Arms

SIZE	ORDERING NUMBER	ITEM CODE	WT. KG.
CS	HSA8CS	62505	1.1
CM	HSA8CM	62506	1.3
CL	HSA8CL	62507	1.5
CLL	HSA8CLL	62508	1.7

Suspension Arm Size

HEAD PULLEY DIAMETER + BELT & LAGGING mm	SUSPENSION ARM SIZE
500-799	CS
800-999	CM
1000-1199	CL
1200-1700	CLL

Over 1700mm - contact Flexco

Tips required per cleaner size

BELT WIDTH mm	BELT COVERAGE mm	V-TIPS REQUIRED
600	600	3
800	800	4
1000	1000	5
1200	1200	6
1400	1400	7
1600	1600	8
1800	1800	9
2000	2000	10
2200	2200	11
2400	2400	12
2600	2600	13
2800	2800	14
3000	3000	15

Stock items (non-shaded) refer to (*) for specific lead time, if not specified, standard lead time applies.

Non-stock items (shaded) please contact Flexco for dispatch options and lead times.

U.S. Patent No. 7,987,966; 8,757,360; 8,312,986;
8,640,856; 9,090,405; 9,085,419; 6,926,133; 7,347,315

Product Ordering Information

H-Type ESAC with Extra Life V-Tips (Mild Steel) HD Primary Cleaner with Enhanced Service Advantage Cartridge™

H-Type ESAC Mild Steel Replacement Cartridge Kits with Extra Life V-Tips

TIP WIDTH	ARM SIZE	ORDERING NUMBER	ITEM CODE	Wght. KG.
Single Cartridge Kits				
600	CS	H-CARK-600-CS-EL15	63631	23.2
	CM	H-CARK-600-CM-EL15	63632	24
	CL	H-CARK-600-CL-EL15	63633	24.5
800	CS	H-CARK-800-CS-EL15	63634	30.3
	CM	H-CARK-800-CM-EL15	63635	31.3
	CL	H-CARK-800-CL-EL15	63636	31.9
1000	CS	H-CARK-1000-CS-EL15	63637	36.1
	CM	H-CARK-1000-CM-EL15	63638	37.4
	CL	H-CARK-1000-CL-EL15	63639	38.2
1200	CS	H-CARK-1200-CS-EL15	63640	41.4
	CM	H-CARK-1200-CM-EL15	63641	43.3
	CL	H-CARK-1200-CL-EL15	63642	44.2
1400	CS	H-CARK-1400-CS-EL15	63643	49
	CM	H-CARK-1400-CM-EL15	63644	50.8
	CL	H-CARK-1400-CL-EL15	63645	51.9
1600	CM	H-CARK-1600-CS-EL15	63646	58.1
	CL	H-CARK-1600-CM-EL15	63647	59.3
	CLL	H-CARK-1600-CL-EL15	63648	63.1
1800	CM	H-CARK-1800-CS-EL15	63649	66.2
	CL	H-CARK-1800-CM-EL15	63650	67.6
	CLL	H-CARK-1800-CL-EL15	63651	71.9
Dual Cartridge Kits				
1200	CS	H-CARK2-1200-CS-EL15	63567	46.2
	CM	H-CARK2-1200-CM-EL15	63568	47.8
	CL	H-CARK2-1200-CL-EL15	63569	48.7
	CLL	H-CARK2-1200-CLL-EL15	63570	51.6
1400	CS	H-CARK2-1400-CS-EL15	63571	51.8
	CM	H-CARK2-1400-CM-EL15	63572	53.6
	CL	H-CARK2-1400-CL-EL15	63573	54.6
	CLL	H-CARK2-1400-CLL-EL15	63574	58
1600	CM	H-CARK2-1600-CM-EL15	63575	59.4
	CL	H-CARK2-1600-CL-EL15	63576	60.6
	CLL	H-CARK2-1600-CLL-EL15	63577	64.4
1800	CM	H-CARK2-1800-CM-EL15	63578	68.1
	CL	H-CARK2-1800-CL-EL15	63579	69.4
	CLL	H-CARK2-1800-CLL-EL15	63580	73.8
2000	CM	H-CARK2-2000-CM-EL15	63581	74.8
	CL	H-CARK2-2000-CL-EL15	63582	76.3
	CLL	H-CARK2-2000-CLL-EL15	63583	81.1
2200	CM	H-CARK2-2200-CM-EL15	63584	82.1
	CL	H-CARK2-2200-CL-EL15	63585	83.7
	CLL	H-CARK2-2200-CLL-EL15	63586	89
2400	CM	H-CARK2-2400-CM-EL15	63587	87.1
	CL	H-CARK2-2400-CL-EL15	63588	88.9
	CLL	H-CARK2-2400-CLL-EL15	63589	94.7
2600	CM	H-CARK2-2600-CM-EL15	63590	95.7
	CL	H-CARK2-2600-CL-EL15	63591	97.7
	CLL	H-CARK2-2600-CLL-EL15	63592	103.9
2800	CM	H-CARK2-2800-CM-EL15	63593	102.2
	CL	H-CARK2-2800-CL-EL15	63594	104.3
	CLL	H-CARK2-2800-CLL-EL15	63595	111
3000	CM	H-CARK2-3000-CM-EL15	63596	107.7
	CL	H-CARK2-3000-CL-EL15	63597	110
	CLL	H-CARK2-3000-CLL-EL15	63598	117.2

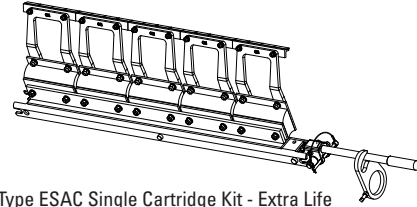

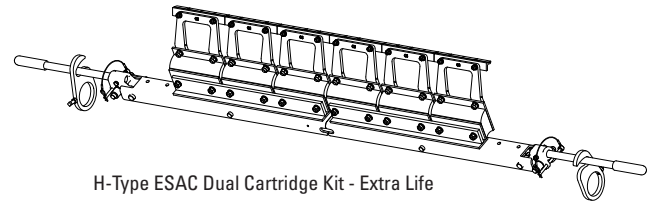

H-Type ESAC Single Cartridge Kit - Extra Life



H-Type ESAC Dual Cartridge Kit - Extra Life

U.S. Patent No. 7,987,966; 8,757,360; 8,312,986;
8,640,856; 9,090,405; 9,085,419; 6,926,133; 7,347,315

 **Stock items** (non-shaded) refer to (*) for specific lead time, if not specified, standard lead time applies.
 **Non-stock items** (shaded) please contact Flexco for dispatch options and lead times.

www.flexco.com • toll-free phone: +1300-098-435



51

U.S. Patent No. 6,926,133; 7,347,315

Product Ordering Information

H-Type ESAC with Extra Life V-Tips (Stainless Steel) HD Primary Cleaner with Enhanced Service Advantage Cartridge™

Stainless Steel H-Type® ESAC with Extra Life V-Tips

TIP WIDTH	ARM SIZE	ORDERING NUMBER	ITEM CODE	Wght. KG.
Single Cartridge				
600	CS	HV-600-SAC-CS-S/S-EL15	63227	74.2
	CM	HV-600-SAC-CM-S/S-EL15	63228	74.9
	CL	HV-600-SAC-CL-S/S-EL15	63229	75.3
800	CS	HV-800-SAC-CS-S/S-EL15	63230	86.5
	CM	HV-800-SAC-CM-S/S-EL15	63231	87.5
	CL	HV-800-SAC-CL-S/S-EL15	63232	88.1
1000	CS	HV-1000-SAC-CS-S/S-EL15	63233	94.9
	CM	HV-1000-SAC-CM-S/S-EL15	63234	96.2
	CL	HV-1000-SAC-CL-S/S-EL15	63235	96.9
1200	CS	HV-1200-SAC-CS-S/S-EL15	63236	103.3
	CM	HV-1200-SAC-CM-S/S-EL15	63237	104.7
	CL	HV-1200-SAC-CL-S/S-EL15	63238	105.6
1400	CS	HV-1400-SAC-CS-S/S-EL15	63239	115.9
	CM	HV-1400-SAC-CM-S/S-EL15	63240	117.5
	CL	HV-1400-SAC-CL-S/S-EL15	63241	118.6
1600	CM	HV-1600-SAC-CM-S/S-EL15	63242	130.0
	CL	HV-1600-SAC-CL-S/S-EL15	63243	131.3
	CLL	HV-1600-SAC-CLL-S/S-EL15	63244	135.2
1800	CM	HV-1800-SAC-CM-S/S-EL15	63245	137.2
	CL	HV-1800-SAC-CL-S/S-EL15	63246	138.5
	CLL	HV-1800-SAC-CLL-S/S-EL15	63247	142.8
Dual Cartridge				
1200	CS	HV-1200-2SAC-CS-S/S-EL15	63453	128.7
	CM	HV-1200-2SAC-CM-S/S-EL15	63454	130.3
	CL	HV-1200-2SAC-CL-S/S-EL15	63455	131.2
	CLL	HV-1200-2SAC-CLL-S/S-EL15	63456	134.1
1400	CS	HV-1400-2SAC-CS-S/S-EL15	63457	137.4
	CM	HV-1400-2SAC-CM-S/S-EL15	63458	139.0
	CL	HV-1400-2SAC-CL-S/S-EL15	63459	140.1
	CLL	HV-1400-2SAC-CLL-S/S-EL15	63460	143.4
1600	CM	HV-1600-2SAC-CM-S/S-EL15	63461	147.9
	CL	HV-1600-2SAC-CL-S/S-EL15	63462	149.1
	CLL	HV-1600-2SAC-CLL-S/S-EL15	63463	152.9
1800	CM	HV-1800-2SAC-CM-S/S-EL15	63464	159.5
	CL	HV-1800-2SAC-CL-S/S-EL15	63465	160.9
	CLL	HV-1800-2SAC-CLL-S/S-EL15	63466	163.8
2000	CM	HV-2000-2SAC-CM-S/S-EL15	63467	169.2
	CL	HV-2000-2SAC-CL-S/S-EL15	63468	170.7
	CLL	HV-2000-2SAC-CLL-S/S-EL15	63469	174.0
2200	CM	HV-2200-2SAC-CM-S/S-EL15	63470	182.4
	CL	HV-2200-2SAC-CL-S/S-EL15	63471	184.1
	CLL	HV-2200-2SAC-CLL-S/S-EL15	63472	187.7
2400	CM	HV-2400-2SAC-CM-S/S-EL15	63473	187.5
	CL	HV-2400-2SAC-CL-S/S-EL15	63474	189.3
	CLL	HV-2400-2SAC-CLL-S/S-EL15	63475	193.3
2600	CM	HV-2600-2SAC-CM-S/S-EL15	63476	211.2
	CL	HV-2600-2SAC-CL-S/S-EL15	63477	213.2
	CLL	HV-2600-2SAC-CLL-S/S-EL15	63478	217.4
2800	CM	HV-2800-2SAC-CM-S/S-EL15	63479	220.9
	CL	HV-2800-2SAC-CL-S/S-EL15	63480	223.0
	CLL	HV-2800-2SAC-CLL-S/S-EL15	63481	227.7
3000	CM	HV-3000-2SAC-CM-S/S-EL15	63482	230.0
	CL	HV-3000-2SAC-CL-S/S-EL15	63483	232.3
	CLL	HV-3000-2SAC-CLL-S/S-EL15	63484	237.2

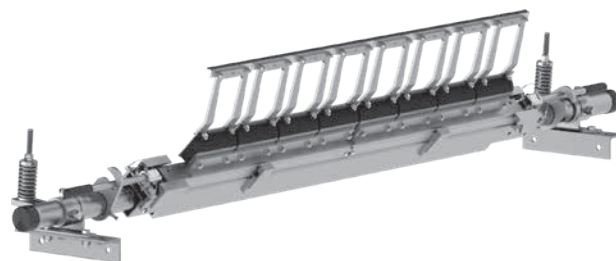

Stainless Steel H-Type ESAC Dual HD Primary Cleaner

Replacement V-Tips

ORDERING NUMBER	ITEM CODE	WT. KG.
HVT8-S/S	75419	0.9
HVPT-S/S	73631	1.2

Replacement Suspension Arms SS

SIZE	ORDERING NUMBER	ITEM CODE	WT. KG.
CS	HSA8CS-S/S	62509	1.1
CM	HSA8CM-S/S	62510	1.3
CL	HSA8CL-S/S	62511	1.5
CLL	HSA8CLL-S/S	62512	1.7

Suspension Arm Size

HEAD PULLEY DIAMETER + BELT & LAGGING mm	SUSPENSION ARM SIZE
500-799	CS
800-999	CM
1000-1199	CL
1200-1700	CLL

Over 1700mm - contact Flexco

Tips required per cleaner size

BELT WIDTH mm	BELT COVERAGE mm	V-TIPS REQUIRED
600	600	3
800	800	4
1000	1000	5
1200	1200	6
1400	1400	7
1600	1600	8
1800	1800	9
2000	2000	10
2200	2200	11
2400	2400	12
2600	2600	13
2800	2800	14
3000	3000	15

Stock items (non-shaded) refer to (*) for specific lead time, if not specified, standard lead time applies.

Non-stock items (shaded) please contact Flexco for dispatch options and lead times.

U.S. Patent No. 7,987,966; 8,757,360; 8,312,986;
8,640,856; 9,090,405; 9,085,419; 6,926,133; 7,347,315

Product Ordering Information

H-Type ESAC with Extra Life V-Tips (Stainless Steel) HD Primary Cleaner with Enhanced Service Advantage Cartridge™

H-Type ESAC Stainless Steel Replacement Cartridge Kits with Extra Life V-Tips

TIP WIDTH	ARM SIZE	ORDERING NUMBER	ITEM CODE	Wght. KG.
Single Cartridge Kits				
600	CS	H CARK-600-CS-S/S-EL15	63652	23.2
	CM	H CARK-600-CM-S/S-EL15	63653	24
	CL	H CARK-600-CL-S/S-EL15	63654	24.5
800	CS	H CARK-800-CS-S/S-EL15	63655	30.3
	CM	H CARK-800-CM-S/S-EL15	63656	31.3
	CL	H CARK-800-CL-S/S-EL15	63657	31.9
1000	CS	H CARK-1000-CS-S/S-EL15	63658	36.1
	CM	H CARK-1000-CM-S/S-EL15	63659	37.4
	CL	H CARK-1000-CL-S/S-EL15	63660	38.2
1200	CS	H CARK-1200-CS-S/S-EL15	63661	41.4
	CM	H CARK-1200-CM-S/S-EL15	63662	43.3
	CL	H CARK-1200-CL-S/S-EL15	63663	44.2
1400	CS	H CARK-1400-CS-S/S-EL15	63664	49
	CM	H CARK-1400-CM-S/S-EL15	63665	50.8
	CL	H CARK-1400-CL-S/S-EL15	63666	51.9
1600	CM	H CARK-1600-CS-S/S-EL15	63667	58.1
	CL	H CARK-1600-CM-S/S-EL15	63668	59.3
	CLL	H CARK-1600-CL-S/S-EL15	63669	63.1
1800	CM	H CARK-1800-CS-S/S-EL15	63670	66.2
	CL	H CARK-1800-CM-S/S-EL15	63671	67.6
	CLL	H CARK-1800-CL-S/S-EL15	63672	71.9
Dual Cartridge Kits				
1200	CS	H-CARK2-1200-CS-S/S-EL15	63599	46.2
	CM	H-CARK2-1200-CM-S/S-EL15	63600	47.8
	CL	H-CARK2-1200-CL-S/S-EL15	63601	48.7
	CLL	H-CARK2-1200-CLL-S/S-EL15	63602	51.6
1400	CS	H-CARK2-1400-CS-S/S-EL15	63603	51.8
	CM	H-CARK2-1400-CM-S/S-EL15	63604	53.6
	CL	H-CARK2-1400-CL-S/S-EL15	63605	54.6
	CLL	H-CARK2-1400-CLL-S/S-EL15	63606	58
1600	CM	H-CARK2-1600-CM-S/S-EL15	63607	59.4
	CL	H-CARK2-1600-CL-S/S-EL15	63608	60.6
	CLL	H-CARK2-1600-CLL-S/S-EL15	63609	64.4
1800	CM	H-CARK2-1800-CM-S/S-EL15	63610	68.1
	CL	H-CARK2-1800-CL-S/S-EL15	63611	69.4
	CLL	H-CARK2-1800-CLL-S/S-EL15	63612	73.8
2000	CM	H-CARK2-2000-CM-S/S-EL15	63613	74.8
	CL	H-CARK2-2000-CL-S/S-EL15	63614	76.3
	CLL	H-CARK2-2000-CLL-S/S-EL15	63615	81.1
2200	CM	H-CARK2-2200-CM-S/S-EL15	63616	82.1
	CL	H-CARK2-2200-CL-S/S-EL15	63617	83.7
	CLL	H-CARK2-2200-CLL-S/S-EL15	63618	89
2400	CM	H-CARK2-2400-CM-S/S-EL15	63619	87.1
	CL	H-CARK2-2400-CL-S/S-EL15	63620	88.9
	CLL	H-CARK2-2400-CLL-S/S-EL15	63621	94.7
2600	CM	H-CARK2-2600-CM-S/S-EL15	63622	95.7
	CL	H-CARK2-2600-CL-S/S-EL15	63623	97.7
	CLL	H-CARK2-2600-CLL-S/S-EL15	63624	103.9
2800	CM	H-CARK2-2800-CM-S/S-EL15	63625	102.2
	CL	H-CARK2-2800-CL-S/S-EL15	63626	104.3
	CLL	H-CARK2-2800-CLL-S/S-EL15	63627	111
3000	CM	H-CARK2-3000-CM-S/S-EL15	63628	107.7
	CL	H-CARK2-3000-CL-S/S-EL15	63629	110
	CLL	H-CARK2-3000-CLL-S/S-EL15	63630	117.2

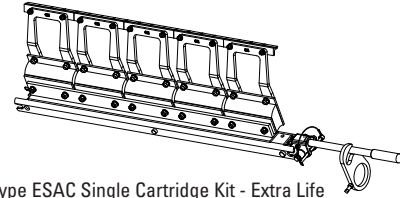

H-Type ESAC Single Cartridge Kit - Extra Life

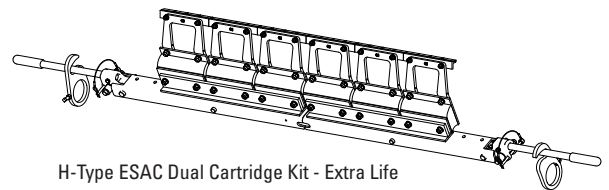

H-Type ESAC Dual Cartridge Kit - Extra Life

U.S. Patent No. 7,987,966; 8,757,360; 8,312,986;
8,640,856; 9,090,405; 9,085,419; 6,926,133; 7,347,315

Stock items (non-shaded) refer to (*) for specific lead time, if not specified, standard lead time applies.

Non-stock items (shaded) please contact Flexco for dispatch options and lead times.

Replacement Parts List

H-Type ESAC with Extra Life V-Tips Single HD Primary Cleaner with Enhanced Service Advantage Cartridge™

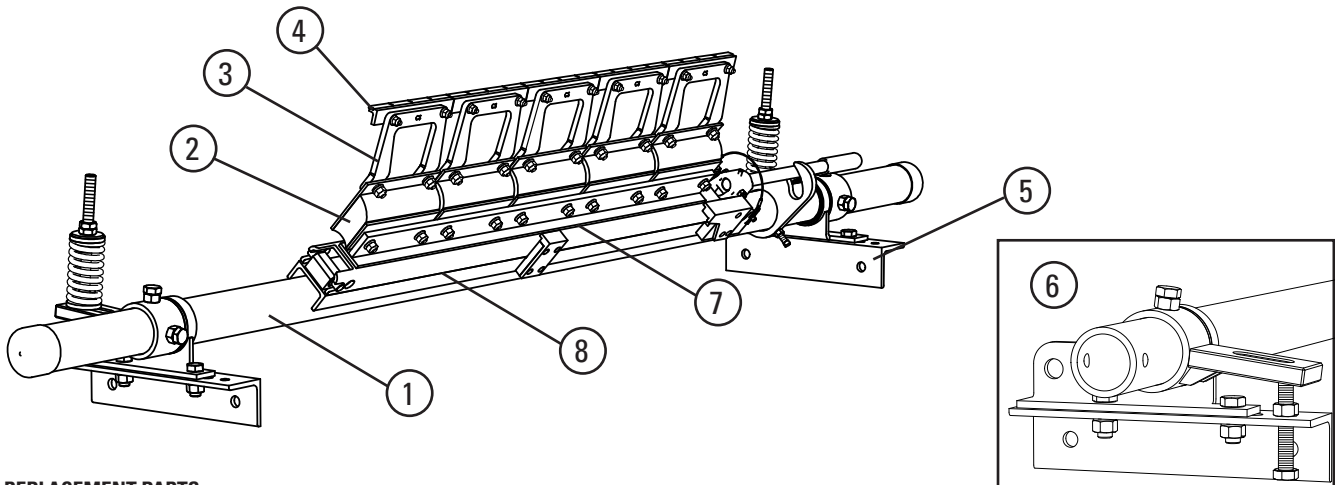

REPLACEMENT PARTS

REF	DESCRIPTION	MILD STEEL			STAINLESS STEEL		
		ORDERING NUMBER	ITEM CODE	WT. KG.	ORDERING NUMBER	ITEM CODE	WT. KG.
1	H-Type Single ESAC Cartridge Pole	HCP-600	62751	30.5	HCP-600-S/S	62757	31.4
		HCP-800	62752	35.6	HCP-800-S/S	62758	36.7
		HCP-1000	62753	38.1	HCP-1000-S/S	62759	39.3
		HCP-1200	62754	40.7	HCP-1200-S/S	62760	42
		HCP-1400	62755	45.9	HCP-1400-S/S	62761	47.3
		HCP-1800	62756	51.0	HCP-1800-S/S	62762	52.6
2	HD Cushion	HSHD	73483	2.0	HSHD-S/S	76467	2.0
3	Suspension Arm	HSA8CS	62505	0.9	HSA8CS-S/S	62509	1.0
		HSA8CM	62506	1.1	HSA8CM-S/S	62510	1.2
		HSA8CL	62507	1.3	HSA8CL-S/S	62511	1.3
		HSA8CLL	62508	1.8	HSA8CLL-S/S	62512	1.8
4	HV Tips	HSA200	73489	0.5	HVT8-S/S	75419	0.6
	HV EL15 Tips	HSA200-EL15	76027	0.5	HVT8-EL15-S/S	62254	0.6
	-	-	-	-	HVPT-S/S	73631	0.6
5	Black Compression Spring Side Assembly (to 1600 belt width max)	H73CSK-B	62749	17.8	H73CSK-B-S/S	62750	18.3
	Gold Compression Spring Side Assembly (to 2400 belt width max)	H73CSK-G	62743	17.8	H73CSK-G-S/S	62744	18.3
6	Bolt Tension Side Assembly	H73BTK	63079	15.1	H73BTK-S/S	63080	15.6

REF	DESCRIPTION	TIP WIDTH	ORDERING NUMBER	ITEM CODE	WT. KG.
7	H-Type Cartridge Adapter Plate	600	H-SAC-AP-600	62452	3.5
		800	H-SAC-AP-800	62453	4.8
		1000	H-SAC-AP-1000	62454	6.0
		1200	H-SAC-AP-1200	62455	7.3
		1400	H-SAC-AP-1400	62456	8.5
		1600	H-SAC-AP-1600	62457	9.8
		1800	H-SAC-AP-1800	62458	11.0
8	SAC Replacement Single Cartridge	600	CART-24/600-S/S	78576	4.5
		800	CART-36/900-S/S	78578	6.7
		1000	CART-42/1050-S/S	78579	7.8
		1200	CART2-48/1200-S/S	78580	8.9
		1400	CART-60/1500-S/S	78582	11.3
		1600	CART-72/1800-S/S	78583	13.5
		1800			

HV/HVP Single SAC Black Spring Length Chart (for optimal blade tensioning)

Belt Width	CS	CM	CL	CLL
600	111	110	109	107
800	109	107	107	104
1000	106	105	104	100
1200	104	102	101	97
1400	102	100	98	93
1600	100	97	96	90
1800	97	95	93	-

HV/HVP Single SAC Gold Spring Length Chart (for optimal blade tensioning)

Belt Width	CS	CM	CL	CLL
600	113	113	112	111
800	112	111	111	109
1000	111	110	109	107
1200	109	108	107	105
1400	108	106	106	102
1600	106	105	104	100
1800	105	103	102	98

HV/HVP Dual SAC Gold Spring Length Chart (for optimal blade tensioning)

Belt Width	CS	CM	CL	CLL
1200	109	108	108	105
1400	108	107	106	103
1600	107	105	104	101
1800	105	104	103	99
2000	104	102	101	96
2200	103	101	99	94

HV/HVP Dual SAC Silver Spring Length Chart (for optimal blade tensioning)

Belt Width	CS	CM	CL	CLL
2200	159	158	157	154
2400	158	157	156	153
2600	157	156	155	151
2800	157	155	154	150
3000	156	154	153	149

U.S. Patent No. 7,987,966; 8,757,360; 8,312,986;
8,640,856; 9,090,405; 9,085,419; 6,926,133; 7,347,315

Stock items (non-shaded) refer to (*) for specific lead time, if not specified, standard lead time applies.

Non-stock items (shaded) please contact Flexco for dispatch options and lead times.

Replacement Parts List

H-Type ESAC with Extra Life V-Tips Dual HD Primary Cleaner with Enhanced Service Advantage Cartridge™

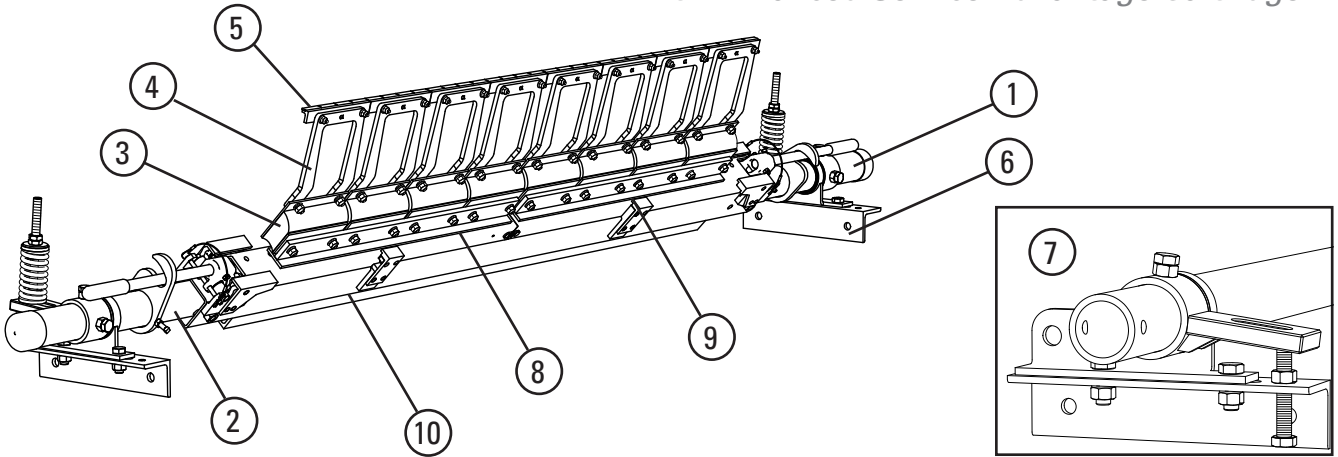

REPLACEMENT PARTS

REF	DESCRIPTION	MILD STEEL			STAINLESS STEEL		
		ORDERING NUMBER	ITEM CODE	WT. KG.	ORDERING NUMBER	ITEM CODE	WT. KG.
1	H-Type Dual ESAC Centre Pole	H2CP-1200	62763	39.7	H2CP-1200-S/S	62801	39.7
		H2CP-1400	62764	42.6	H2CP-1400-S/S	62802	42.6
		H2CP-1600	62765	45.7	H2CP-1600-S/S	62803	45.7
		H2CP-1800	62766	48.6	H2CP-1800-S/S	62804	48.6
		H2CP-2000	62767	51.6	H2CP-2000-S/S	62805	51.6
		H2CP-2400	62768	57.6	H2CP-2400-S/S	62806	57.6
		H2CP-2600	62769	71.0	H2CP-2600-S/S	62807	71.0
		H2CP-2800	62770	74.3	H2CP-2800-S/S	62808	74.3
		H2CP-3000	62771	77.8	H2CP-3000-S/S	62809	77.8
2	Extender Pole	MHP-EP	76392	24.5	MHP-EP-S/S	77599	24.5
3	HD Cushion	HSHD	73483	2.0	HSHD-S/S	76467	2.0
4	Suspension Arm	HSA8CS	62505	0.9	HSA8CS-S/S	62509	1.0
		HSA8CM	62506	1.1	HSA8CM-S/S	62510	1.2
		HSA8CL	62507	1.3	HSA8CL-S/S	62511	1.3
		HSA8CLL	62508	1.8	HSA8CLL-S/S	62512	1.8
5	HV Tips	HSA200	73489	0.5	HVT8-S/S	75419	0.6
	HV EL15 Tips	HSA200-EL15	76027	0.5	HVT8-EL15-S/S	63566	0.6
6	Black Compression Spring Side Assembly (to 1600 belt width max)	H73CSK-B	62749	17.8	H73CSK-B-S/S	62750	18.3
	Gold Compression Spring Side Assembly (to 2400 belt width max)	H73CSK-G	62743	17.8	H73CSK-G-S/S	62744	18.3
	Silver 6" Compression Spring Side Assembly (above 2400)	H73CSK-S	62745	18.0	H73CSK-S-S/S	62746	18.4
7	Bolt Tension Side Assembly	H73BTK	63079	15.1	H73BTK-S/S	63080	15.6

REF	DESCRIPTION	TIP WIDTH	ITEM 8/LEFT HAND			ITEM 9/RIGHT HAND		
			ORDERING NUMBER	ITEM CODE	WT. KG.	ORDERING NUMBER	ITEM CODE	WT. KG.
8 & 9	H-Type Cartridge Adapter Plate	1200	H-SAC-AP-600	62452	3.5	H-SAC-AP-600	62452	3.5
		1400	H-SAC-AP-800	62453	4.8	H-SAC-AP-600	62452	3.5
		1600	H-SAC-AP-800	62453	4.8	H-SAC-AP-800	62453	4.8
		1800	H-SAC-AP-1000	62454	6.0	H-SAC-AP-800	62453	4.8
		2000	H-SAC-AP-1000	62454	6.0	H-SAC-AP-1000	62454	6.0
		2200	H-SAC-AP-1200	62455	7.3	H-SAC-AP-1000	62454	6.0
		2400	H-SAC-AP-1200	62455	7.3	H-SAC-AP-1200	62455	7.3
		2600	H-SAC-AP-1400	62456	8.5	H-SAC-AP-1200	62455	7.3
		2800	H-SAC-AP-1400	62456	8.5	H-SAC-AP-1400	62456	8.5
3000	H-SAC-AP-1600	62457	9.8	H-SAC-AP-1400	62456	8.5		

REF	DESCRIPTION	TIP WIDTH	ORDERING NUMBER	ITEM CODE	WT. KG.
10	SAC Replacement Dual Cartridge	1200	CART2-60/1500-S/S	78584	11.2
		1400	CART2-66/1650-S/S	78634	12.3
		1600	CART2-72/1800-S/S	78585	13.4
		1800	CART2-78/1950-S/S	78635	14.5
		2000	CART2-84/2100-S/S	78586	15.6
		2200	CART2-96/2400-S/S	78587	17.8
		2400			
		2600	CART2-114/2850-S/S	78639	23.7
		2800	CART2-120/3000-S/S	78588	22.6
3000	CART2-126/3150-S/S	78640	23.7		

Stock items (non-shaded) refer to (*) for specific lead time, if not specified, standard lead time applies.

Non-stock items (shaded) please contact Flexco for dispatch options and lead times.

Product Ordering Information

Y-Type™ Standard Duty Secondary Cleaner with Carbide or Polyurethane Blades

Y-Type™ Standard Duty with Purple Polyurethane Blades and YST Tension

BELT WIDTH	ORDERING NUMBER	ITEM CODE	WT. KGS.
450	YT-450S	83229	26.8
600	YT-600S	83230	29.5
750	YT-750S	83231	32.3
900	YT-900S	83232	35.0
1050	YT-1050S	83233	37.7
1200	YT-1200S	83234	40.5

Lead time: 2 weeks



Y-Type™ Standard Duty with Carbide Blades and Bolt Tension

BELT WIDTH	ORDERING NUMBER	ITEM CODE	WT. KGS.
450	YTC-450	83223	30.6
600	YTC-600	83224	33.3
750	YTC-750	83225	36.1
900	YTC-900	83226	38.8
1050	YTC-1050	83227	41.5
1200	YTC-1200	83228	44.3

Lead time: 2 weeks

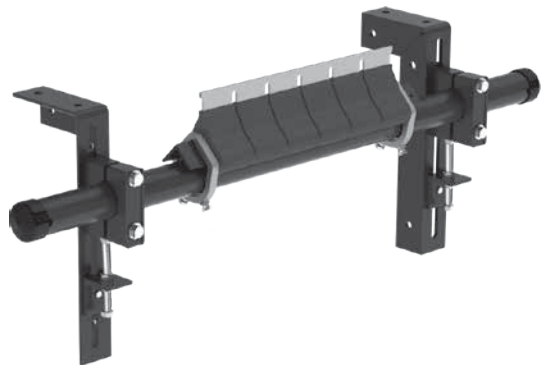



Y-Type™ Standard Duty with Carbide Blades and YST Tension

BELT WIDTH	ORDERING NUMBER	ITEM CODE	WT. KGS.
450	YT-TC-450S	83241	25.0
600	YT-TC-600S	83242	27.3
750	YT-TC-750S	83243	29.5
900	YT-TC-900S	83244	31.8
1050	YT-TC-1050S	83245	34.5
1200	YT-TC-1200S	83246	37.3

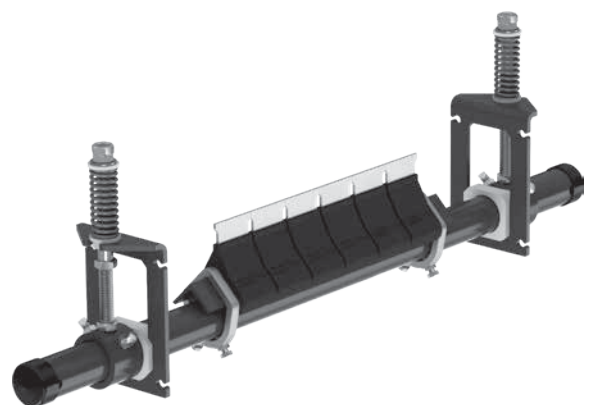
Lead time: 2 weeks



 **Stock items** (non-shaded) refer to (*) for specific lead time, if not specified, standard lead time applies.

 **Non-stock items** (shaded) please contact Flexco for dispatch options and lead times.

U.S. Patent No. 9,586,765

Product Ordering Information

Y-Type™ Heavy Duty Secondary Cleaner with HD Carbide or Urethane Blades

Y-Type™ HD with Purple Polyurethane Blades and YST Tension

BELT WIDTH	ORDERING NUMBER	ITEM CODE	WT. KGS.
900	YTHD-900S	83120	27.1
1050	YTHD-1050S	83121	29.0
1200	YTHD-1200S	83122	30.9
1350	YTHD-1350S	83123	32.8
1500	YTHD-1500S	83124	34.7
1800	YTHD-1800S	83126	38.5

Lead time: 2 weeks

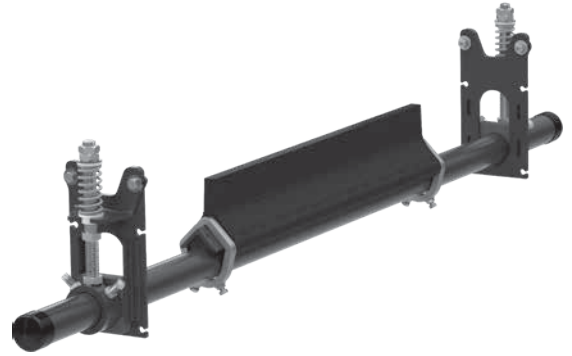

Y-Type™ HD with Carbide Blades and Bolt Tension

BELT WIDTH	ORDERING NUMBER	ITEM CODE	WT. KGS.
900	YTCHD-900	83099	26.9
1050	YTCHD-1050	83100	29.4
1200	YTCHD-1200	83101	31.4
1350	YTCHD-1350	83102	33.4
1500	YTCHD-1500	83103	35.3
1800	YTCHD-1800	83105	39.3

Lead time: 2 weeks



Y-Type™ HD with Carbide Blades and YST Tension

BELT WIDTH	ORDERING NUMBER	ITEM CODE	WT. KGS.
900	YTHD-TC-900S	83134	26.9
1050	YTHD-TC-1050S	83135	29.4
1200	YTHD-TC-1200S	83136	31.4
1350	YTHD-TC-1350S	83137	33.4
1500	YTHD-TC-1500S	83138	35.3
1800	YTHD-TC-1800S	83140	39.3

Lead time: 2 weeks



U.S. Patent No. 9,586,765

 Stock items (non-shaded) refer to (*) for specific lead time, if not specified, standard lead time applies.

 Non-stock items (shaded) please contact Flexco for dispatch options and lead times.

Product Ordering Information

Stainless Steel Y-Type™ Secondary Cleaners

Stainless Steel Y-Type™ SD with Carbide Blades and Bolt Tensioner

BELT WIDTH	ORDERING NUMBER	ITEM CODE
600	YTC600-BT-S/S SECONDARY	67285
750	YTC750-BT-S/S SECONDARY	67286
900	YTC900-BT-S/S SECONDARY	67287
1050	YTC1050-BT-S/S SECONDARY	67288
1200	YTC1200-BT-S/S SECONDARY	67289

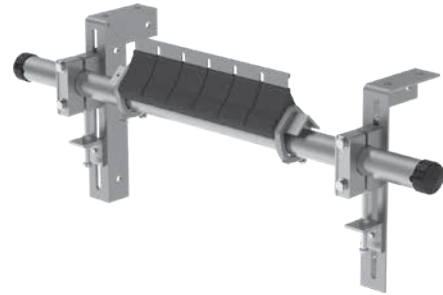

Stainless Steel Y-Type™ HD with Carbide Blades and Bolt Tensioner

BELT WIDTH	ORDERING NUMBER	ITEM CODE
900	YTCHD900-BT-S/S SECONDARY	67290
1050	YTCHD1050-BT-S/S SECONDARY	67291
1200	YTCHD1200-BT-S/S SECONDARY	67292
1350	YTCHD1350-BT-S/S SECONDARY	67293
1500	YTCHD1500-BT-S/S SECONDARY	67294
1800	YTCHD1800-BT-S/S SECONDARY	67295

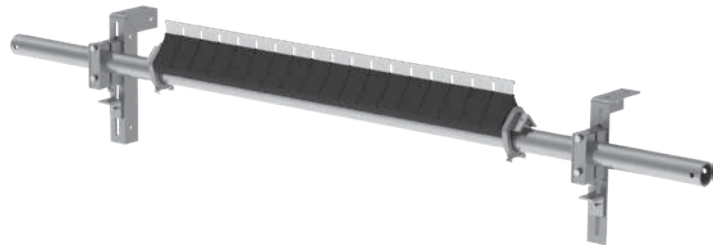

Stainless Steel Y-Type™ HD with Carbide Blades and MST Tensioner

BELT WIDTH	ORDERING NUMBER	ITEM CODE
900	YTCHD900-MST-S/S SECONDARY	67308
1050	YTCHD1050-MST-S/S SECONDARY	67309
1200	YTCHD1200-MST-S/S SECONDARY	67310
1350	YTCHD1350-MST-S/S SECONDARY	67311
1500	YTCHD1500-MST-S/S SECONDARY	67312
1800	YTCHD1800-MST-S/S SECONDARY	67313

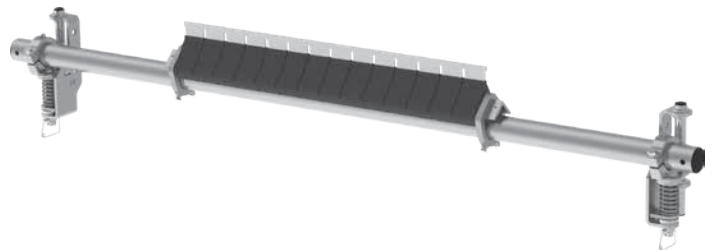

Stainless Steel Y-Type™ HD with Polyurethane Blades and MST Tensioner

BELT WIDTH	ORDERING NUMBER	ITEM CODE
900	YTFHD900-MST-S/S SECONDARY	67314
1050	YTFHD1050-MST-S/S SECONDARY	67315
1200	YTFHD1200-MST-S/S SECONDARY	67316
1350	YTFHD1350-MST-S/S SECONDARY	67317
1500	YTFHD1500-MST-S/S SECONDARY	67318
1800	YTFHD1800-MST-S/S SECONDARY	67319



Product Ordering Information

Y-Type™ Secondary Cleaner with Carbide or Urethane Blades

Replacment Blades/Cartridges - Standard Duty Carbide

BELT WIDTH	ORDERING NUMBER	ITEM CODE	WT. KGS.
-	YT-C*	79574	0.5
450	YCART-18/450-TC	79811	5.7
600	YCART-24/600-TC	79812	7.5
750	YCART-30/750-TC	79813	9.3
900	YCART-36/900-TC	79814	11.0
1050	YCART-42/1050-TC	79815	12.8
1200	YCART-48/1200-TC	79816	14.5

*Single 75mm (3") blade segment
Lead time: 2 weeks

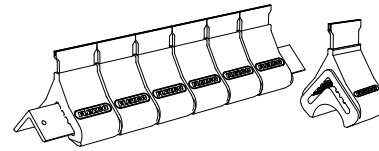

Y-Type™ Standard Duty
Carbide Blade Cartridge

Replacment Blades/Cartridges - Standard Duty Purple Polyurethane

BELT WIDTH	ORDERING NUMBER	ITEM CODE	WT. KGS.
-	YT-P*	79573	0.5
450	YCART-18/450-P	79617	6.0
600	YCART-24/600-P	79618	7.8
750	YCART-30/750-P	79619	9.6
900	YCART-36/900-P	79620	11.4
1050	YCART-42/1050-P	79621	13.2
1200	YCART-48/1200-P	79622	15.0

*Single 75mm (3") blade segment
Lead time: 2 weeks

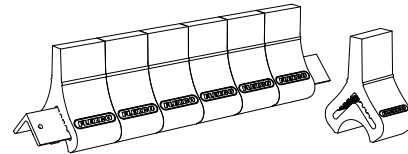

Y-Type™ Standard Duty
Polyurethane Blade Cartridge

Replacment Blades/Cartridges - Heavy-Duty Carbide

BELT WIDTH	ORDERING NUMBER	ITEM CODE	WT. KGS.
-	YT-HDC*	79728	0.8
900	YCART-36/900-HDTC	79829	17.5
1050	YCART-42/1050-HDTC	79830	20.2
1200	YCART-48/1200-HDTC	79831	23.0
1350	YCART-54/1350-HDTC	79832	25.8
1500	YCART-60/1500-HDTC	79833	28.6
1800	YCART-72/1800-HDTC	79834	34.2

*Single 75mm (3") blade segment
Lead time: 2 weeks

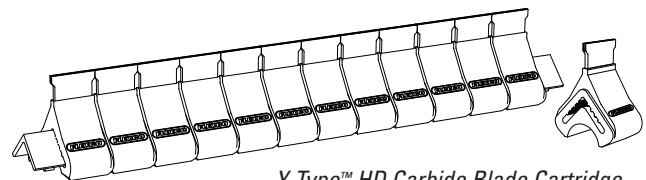

Y-Type™ HD Carbide Blade Cartridge

Replacment Blades/Cartridges - Heavy-Duty Purple Polyurethane

BELT WIDTH	ORDERING NUMBER	ITEM CODE	WT. KGS.
-	YT-HDP*	79677	0.8
900	YCART-36/900-HDP	79817	16.6
1050	YCART-42/1050-HDP	79818	19.2
1200	YCART-48/1200-HDP	79819	21.9
1350	YCART-54/1350-HDP	79820	24.5
1500	YCART-60/1500-HDP	79821	27.2
1800	YCART-72/1800-HDP	79822	32.5

*Single 75mm (3") blade segment
Lead time: 2 weeks

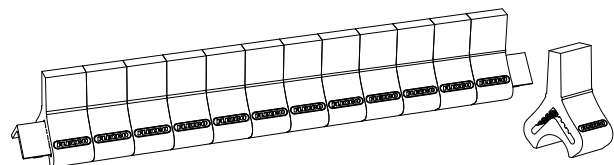

Y-Type™ HD Polyurethane Blade Cartridge

Stock items (non-shaded) refer to (*) for specific lead time, if not specified, standard lead time applies.
Non-stock items (shaded) please contact Flexco for dispatch options and lead times.

Specifications & Guidelines

Y-Type™ Standard Duty Secondary Cleaner with Carbide or Polyurethane Blades

Pole Length Specifications

Cleaner Size		Pole Length		Maximum Conveyor Span	
mm	in.	mm	in.	mm	in.
450	18	1200	48	1025	40
600	24	1350	54	1175	46
750	30	1500	60	1325	52
900	36	1650	66	1475	58
1050	42	1800	72	1625	64
1200	48	1950	78	1775	70

Pole Length - Belt +750mm (30")
 Pole Diameter - 60mm (2-3/8")

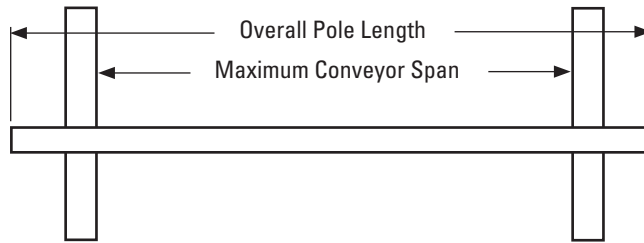

Clearance Guidelines for Installation

Cleaner Type	Belt Width/ Cleaner Size		Horizontal Clearance Required		Vertical Clearance Required	
	mm	in.	mm	in.	mm	in.
Y-Type® Polyurethane	450 - 1200	18 - 48	110	4-1/4	210	8-1/4
Y-Type Carbide	450 - 1200	18 - 48	110	4-1/4	184	7-3/4

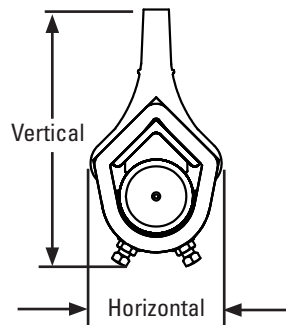

Y-Type Blade Specifications

Cushion	Durometer	Temperature Range
Purple (Standard)	86A	-35° to 82° C -30° to 180° F
Carbide	86A	-35° to 82° C -30° to 180° F

‡ All ingredients used in the Polyurethane formulation of this blade comply with the relevant requirements of 21 CFR (FDA Code of Federal Regulations) for use in repeated bulk dry food applications

Spring Length Chart

Blade Width		Carbide Tip		Polyurethane Tip			
		Silver Springs		Yellow Springs		Purple Springs	
mm	in.	mm	in.	mm	in.	mm	in.
450	18	105	4 1/8	83	3 1/4	92	3 5/8
600	24	102	4	73	2 7/8	86	3 3/8
750	30	98	3 7/8	67	2 5/8	79	3 1/8
900	36	95	3 3/4	57	2 1/4	73	2 7/8
1050	42	92	3 5/8	NA	NA	67	2 5/8
1200	48	89	3 1/2	NA	NA	60	2 3/8

Shading indicates preferred spring option.

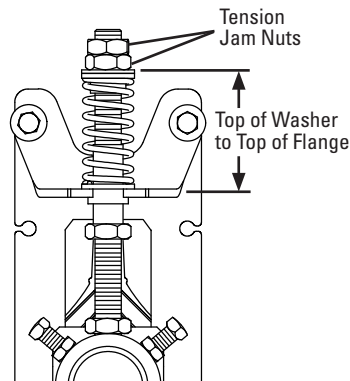

Pull-Up Tensioner Configuration (SD)

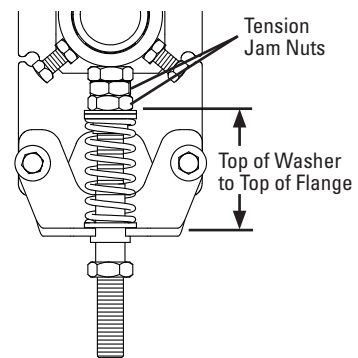

Push-Up Tensioner Configuration (SD)

Specifications:

- Maximum Belt Speed.....3M/sec (600 FPM)
- Temperature Rating-35°C to 82°C (-30°F to 180°F)
- Usable Blade Wear Length.....50mm (2") (Polyurethane)
6mm (1/4") (Carbide)
- Blade Materials.....**Purple:** Polyurethane (proprietary blend for abrasion resistance and long wear)
Carbide: Tungsten Carbide
- Available for Belt Widths450 to 1200mm (18" to 48"). Other sizes available upon request.
- CEMA Cleaner Rating.....Class 2 (Standard-duty with polyurethane blades)
Class 3 (Standard-duty with carbide blades)

U.S. Patent No. 9,586,765

Specifications & Guidelines

Y-Type™ Heavy Duty Secondary Cleaner with HD Carbide or Urethane Blades

Pole Length Specifications

Cleaner Size		Pole Length		Maximum Conveyor Span	
mm	in.	mm	in.	mm	in.
900	36	2286	90	2083	82
1050	42	2438	96	2235	88
1200	48	2590	102	2388	94
1350	54	2743	108	2540	100
1500	60	2895	114	2692	106
1800	72	3200	126	2997	118

Pole Length - Belt +1350mm (54")
Pole Diameter - 73mm (2-7/8")

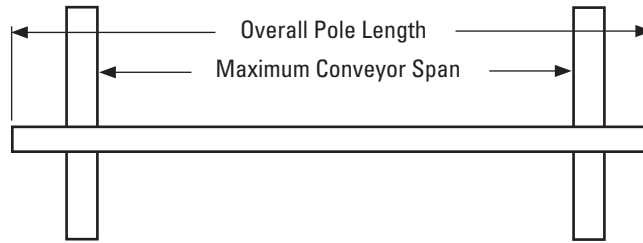

Clearance Guidelines for Installation

Cleaner Type	Belt Width/ Cleaner Size		Horizontal Clearance Required		Vertical Clearance Required	
	mm	in.	mm	in.	mm	in.
Y-Type® HD Polyurethane	900 - 1800	36 - 72	133	5-1/4	241	9-1/2
Y-Type HD Carbide	900 - 1800	36 - 72	133	5-1/4	248	9-3/4

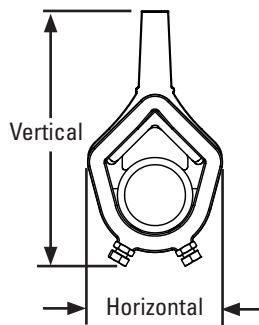

Y-Type Blade Specifications

Cushion	Durometer	Temperature Range
Purple (Standard)	86A	-35° to 82° C -30° to 180° F
Carbide	86	-35° to 82° C -30° to 180° F

‡ All ingredients used in the polyurethane formulation of this blade comply with the relevant requirements of 21 CFR (FDA Code of Federal Regulations) for use in repeated bulk dry food applications

Blade Width		Carbide Tip				Polyurethane Tip			
		Silver Springs		Black Springs		Green Springs		Blue Springs	
mm	in.	mm	in.	mm	in.	mm	in.	mm	in.
900	36	98	3 7/8	102	4	76	3	86	3 3/8
1050	42	95	3 3/4	98	3 7/8	73	2 7/8	83	3 1/4
1200	48	92	3 5/8	95	3 3/4	67	2 5/8	79	3 1/8
900	54	89	3 1/2	95	3 3/4	64	2 1/2	76	3
1050	60	86	3 3/8	92	3 5/8	NA	NA	73	2 7/8
1200	72	83	3 1/4	89	3 1/2	NA	NA	64	2 1/2

Shading indicates preferred spring option.

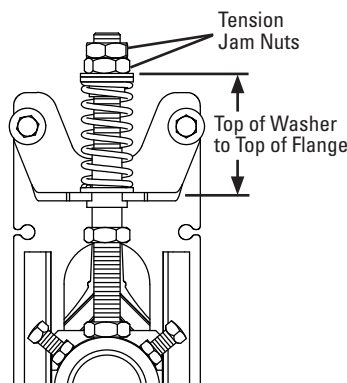

Pull-Up Tensioner Configuration (HD)

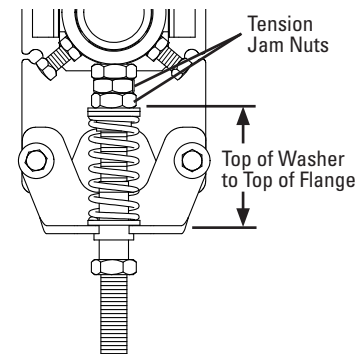

Push-Up Tensioner Configuration (HD)

Specifications:

- Maximum Belt Speed.....3.8M/sec (750 FPM)
- Temperature Rating.....-35°C to 82°C (-30°F to 180°F)
- Usable Blade Wear Length.....75mm (3") (Polyurethane)
10mm (3/8") (Carbide)
- Blade Materials.....**Purple:** Polyurethane (proprietary blend for abrasion resistance and long wear)
Carbide: Tungsten Carbide
- Available for Belt Widths.....900 to 1800mm (36" to 72"). Other sizes available upon request.
- CEMA Cleaner Rating.....Class 3 (Heavy-duty with polyurethane or carbide blades)

U.S. Patent No. 9,586,765

Replacement Parts List

Y-Type™ Standard Duty Secondary Cleaner with Carbide or Polyurethane Blades

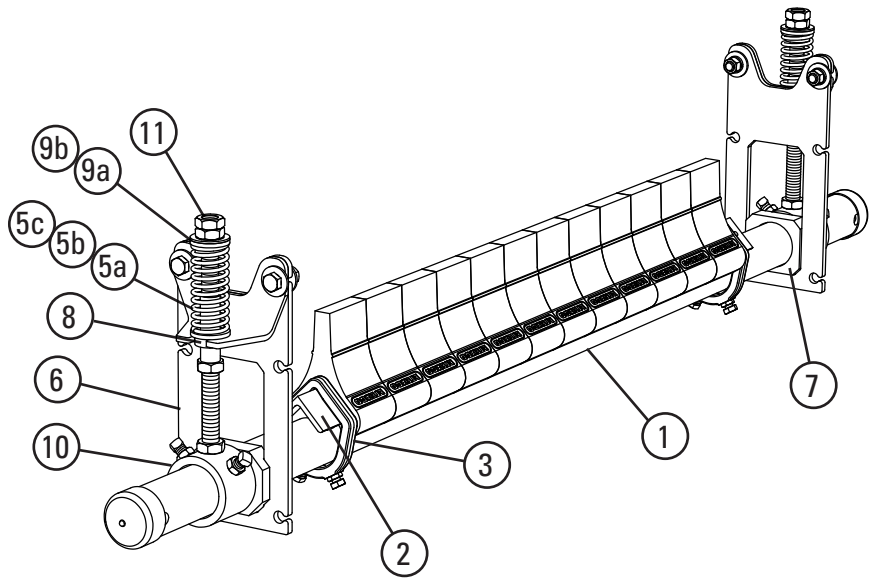
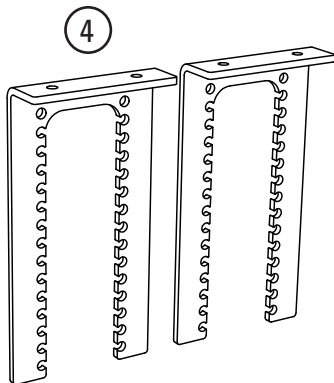

Replacement Parts

REF	DESCRIPTION	ORDERING NUMBER	ITEM CODE	WT. KG.
1	450mm (18") Y-Type™ Pole	YTP-18/450	82932	9.2
	600mm (24") Y-Type Pole	YTP-24/600	82933	10.3
	750mm (30") Y-Type Pole	YTP-30/750	82934	11.5
	900mm (36") Y-Type Pole	YTP-36/900	82935	12.6
	1050mm (42") Y-Type Pole	YTP-42/1050	82936	13.7
	1200mm (48") Y-Type Pole	YTP-48/1200	82937	14.9
2	450mm (18") Y-Type Cushion Angle	YTA-18/450	82949	2.6
	600mm (24") Y-Type Cushion Angle	YTA-24/600	82950	3.3
	750mm (30") Y-Type Cushion Angle	YTA-30/750	82951	4.0
	900mm (36") Y-Type Cushion Angle	YTA-36/900	82952	4.7
	1050mm (42") Y-Type Cushion Angle	YTA-42/1050	82953	5
	1200mm (48") Y-Type Cushion Angle	YTA-48/1200	82954	6.2
3	Y-Type Angle Clamp* (2 Clamps)	YTAC	79623	1.0
4	YST Drop Bracket Kit (2 Brackets)	YSTDBK	79844	9.0
5a	YST Spring Yellow	YSTS-Y	79795	0.1
5b	YST Spring Purple	YSTS-P	79796	0.2
5c	YST Spring Silver (Y-Type Carbide Cleaners)	CTS-S	77743	0.2
6	YST Mounting Bracket (incl. Angle Bracket)	YSTMB	79843	1.5
7	YST Guide Block Kit (Pair)	YSTGBK	79845	0.2
8	YST Lower Bushing Kit (Pair)	YSTLBK	79846	0.0
9a	YST Top Bushing Kit White (Pair)	YSTTBK-W	79847	0.0
9b	YST Top Bushing Kit Black (Pair)	YSTTBK-B	79855	0.0
10	YST Pole Mount Kit*	YSTPMK	79848	2.0
11	YST Adjusting Rod Nut Kit	YSTANK	79857	0.1

*Hardware included
Lead time: 2 weeks

Replacement Parts

REF	DESCRIPTION	ORDERING NUMBER	ITEM CODE	WT. KG.
-	YST Tensioner w/Yellow Spring (Pair) (incl. 2 ea. item 5a, 6, 10, 11; 1 ea. items 7, 8, 9a)	YST-Y	79836	8.3
-	YST Tensioner w/Purple Spring (Pair) (incl. 2 ea. item 5b, 6, 10, 11; 1 ea. items 7, 8, 9a)	YST-P	79837	8.4
-	YST Tensioner w/Silver Spring (Pair) (incl. 2 ea. item 5c, 6, 10, 11; 1 ea. items 7, 8, 9b)	YST-S	79838	8.5
-	P Adjusting Bracket	PAB	75513	1.0
-	P Pole Clamp	PCB	75507	3.0
-	P Mounting Bracket Repair Kit (includes left or right mounting bracket)	PMBL (left)	75516	3.8
-		PMBR (right)	75519	3.8
-	P/R/I Mounting Kit (includes 2 each items PMB, PAB, PCB)	CCMK	78919	12.0

Lead time: 2 weeks

Blades Required per Cleaner Size

mm	450	600	750	900	1050	1200
in.	18	24	30	36	42	48
Blades Required	6	8	10	12	14	16

Spring Tensioner Selection Chart

Cleaner Blade Width	79838 YST-S	79836 YST-Y	79837 YST-P
Carbide 450 - 1200mm (18" - 48")	X		
Polyurethane 450 - 750mm (18" - 30")		X	
Polyurethane 900 - 1200mm (36" - 48")			X

Stock items (non-shaded) refer to (*) for specific lead time, if not specified, standard lead time applies.

Non-stock items (shaded) please contact Flexco for dispatch options and lead times.

U.S. Patent No. 9,586,765

Replacement Parts List

Y-Type™ Heavy Duty Secondary Cleaner with HD Carbide or Urethane Blades

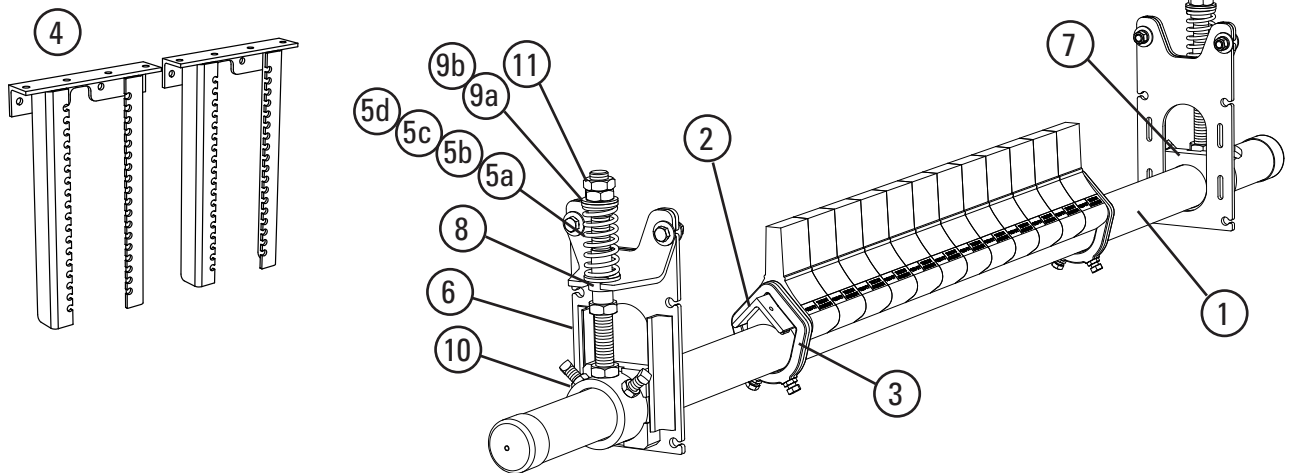

Replacement Parts

REF	DESCRIPTION	ORDERING NUMBER	ITEM CODE	WT. KG.
1	900mm (36") Y-Type™ HD Pole	YTPHD-36/900	83106	27.3
	1050mm (42") Y-Type HD Pole	YTPHD-42/1050	83107	28.8
	1200mm (48") Y-Type HD Pole	YTPHD-48/1200	83108	30.4
	1350mm (54") Y-Type HD Pole	YTPHD-54/1350	83109	31.9
	1500mm (60") Y-Type HD Pole	YTPHD-60/1500	83110	33.5
	1800mm (72") Y-Type HD Pole	YTPHD-72/1800	83112	35.0
2	900mm (36") Y-Type HD Cushion Angle	YTAHD-36/900	79805	7.5
	1050mm (42") Y-Type HD Cushion Angle	YTAHD-42/1050	79806	8.6
	1200mm (48") Y-Type HD Cushion Angle	YTAHD-48/1200	79807	9.7
	1350mm (54") Y-Type HD Cushion Angle	YTAHD-54/1350	79808	10.9
	1500mm (60") Y-Type HD Cushion Angle	YTAHD-60/1500	79809	12.0
	1800mm (72") Y-Type HD Cushion Angle	YTAHD-72/1800	79810	14.2
3	Y-Type HD Angle Clamp* (2 Clamps)	YTACHD	79835	2.2
4	YST HD Drop Bracket Kit (2 Brackets)	YSTHDBK	79850	14.6
5a	YST HD Spring, Green	YSTHDS-GR	79797	0.2
5b	SST Spring, Silver	STS-S	75843	0.4
5c	YST HD Spring, Blue (for Y-Type HD Carbide Cleaners)	YSTHDS-BL	79798	0.3
5d	SST Spring, Black (for Y-Type HD Carbide Cleaners)	STS-B	75844	0.5
6	YST HD Mounting Bracket	YSTHDMB	79849	3.0
7	YST HD Guide Block Kit (Pair)	YSTHDGBK	79851	0.5
8	YST HD Lower Bushing Kit (Pair)	YSTHDLBK	79852	0.05
9a	YST HD Top Bushing Kit White (Pair)	YSTHDBK-W	79853	0.05
9b	YST HD Top Bushing Kit Black (Pair)	YSTHDBK-B	79856	0.05
10	YST HD Pole Mount Kit*	YSTPHDMK	79854	3.5
11	YST Adjusting Rod Nut Kit	YSTANK	79858	0.1

*Hardware included

Replacement Parts

REF	DESCRIPTION	ORDERING NUMBER	ITEM CODE	WT. KG.
-	YST Tensioner w/Silver Spring (Pair) (for belts 36" - 54" w/carbide tips) (incl. 2 ea. item 5b, 6, 10, 11; 1 ea. items 7, 8, 9a)	YSTHD-S	79840	15.2
-	YST Tensioner w/Black Spring (Pair) (for belts 60" - 72" w/carbide tips) (incl. 2 ea. item 5d, 6, 10, 11; 1 ea. items 7, 8, 9b)	YSTHD-BK	79842	15.5
-	YST Tensioner w/Green Spring (Pair) (for belts 36" - 48" w/Polyurethane tips) (incl. 2 ea. item 5a, 6, 10, 11; 1 ea. items 7, 8, 9a)	YSTHD-GR	79839	14.9
-	YST Tensioner w/Blue Spring (Pair) (for belts 54" - 72" w/Polyurethane tips) (incl. 2 ea. item 5c, 6, 10, 11; 1 ea. items 7, 8, 9b)	YSTHD-BL	79841	15.0
-	P Adjusting Bracket	PAB	75513	1.0
-	P Pole Clamp	PHDCB	75510	4.0
-	P Mounting Bracket Repair Kit (includes left or right mounting bracket)	PMBL (left) PMBR (right)	75516 75519	3.8 3.8
-	P/R/I Mounting Kit (includes 2 each items PMB, PAB, PHDCB)	CCMKHD	78920	16.7

Blades Required per Cleaner Size

mm	900	1050	1200	1350	1500	1800
in.	36	42	48	54	60	72
Blades Required	12	14	16	18	20	24

Spring Tensioner Selection Chart

Cleaner Blade Width	Silver YSTHD-S	Black YSTHD-BK	Green YSTHD-GR	Blue YSTHD-BL
Carbide 900 - 1350mm (36" - 54")	X			
Carbide 1500 - 1800mm (60" - 72")		X		
Polyurethane 900 - 1200mm (36" - 48")			X	
Polyurethane 1350 - 1800mm (54" - 72")				X

U.S. Patent No. 9,586,765

Stock items (non-shaded) refer to (*) for specific lead time, if not specified, standard lead time applies.

Non-stock items (shaded) please contact Flexco for dispatch options and lead times.

Replacement Parts List

Stainless Steel Y-Type™ Secondary Cleaners

Replacement Poles

BELT WIDTH	ORDERING NUMBER	ITEM CODE
mm		
600	YPHD600-S/S POLE	67322
750	YPHD750-S/S POLE	67323
900	YPHD900-S/S POLE	64198
1050	YPHD1050-S/S POLE	64199
1200	YPHD1200-S/S POLE	64200
1350	YPHD1350-S/S POLE	64201
1500	YPHD1500-S/S POLE	64202
1800	YPHD1800-S/S POLE	64204

Other

ORDERING NUMBER	ITEM CODE
MSTHD-S-S/S	90182
MSTHD-B-S/S	90183
MSTHD-G-S/S	90184

Replacement Blades/Cartridges - Standard-Duty Carbide

BELT WIDTH	ORDERING NUMBER	ITEM CODE
mm		
600	YCART-S/S-24/600-SDTC	66749
750	YCART-S/S-30/750-SDTC	67750
900	YCART-S/S-36/900-SDTC	67751
1050	YCART-S/S-42/1050-SDTC	67752
1200	YCART-S/S-48/1200-SDTC	67753

Angle List - SD | Angle List - HD

BELT WIDTH	ITEM CODE	BELT WIDTH	ITEM CODE
600	67324	900	64205
750	67325	1050	64206
900	64205	1200	64207
1050	64206	1350	64208
1200	64207	1500	64209
		1800	64211

Replacement Blades/Cartridges - Heavy-Duty Carbide

BELT WIDTH	ORDERING NUMBER	ITEM CODE
mm		
900	YCART-S/S-36/900-HDTC	67411
1050	YCART-S/S-42/1050-HDTC	67412
1200	YCART-S/S-48/1200-HDTC	67413
1350	YCART-S/S-54/1350-HDTC	67414
1500	YCART-S/S-60/1500-HDTC	67415
1800	YCART-S/S-72/1800-HDTC	67416

Angle Clamp Cost

	ITEM CODE
SD	GR298
HD	B0536

Replacement Blades/Cartridges - Heavy-Duty Purple Polyurethane

BELT WIDTH	ORDERING NUMBER	ITEM CODE
mm		
900	YCART-S/S-36/900-HDP	67417
1050	YCART-S/S-42/1050-HDP	67418
1200	YCART-S/S-48/1200-HDP	67419
1350	YCART-S/S-54/1350-HDP	67420
1500	YCART-S/S-60/1500-HDP	67421
1800	YCART-S/S-72/1800-HDP	67422

Stock items (non-shaded) refer to (*) for specific lead time, if not specified, standard lead time applies.

Non-stock items (shaded) please contact Flexco for dispatch options and lead times.

Product Ordering Information

P-Type®
Secondary Cleaner

P-Type® Secondary with V-Tips* Powder Coated

BELT WIDTH mm	ORDERING NUMBER	ITEM CODE	WT. KG.
450	PV450	73435	36.0
600	PV600	73004	37.0
750	PV750	73006	38.0
900	PV900	73008	41.0
1050	PV1050	73010	47.0
1200	PV1200	73012	51.0
1400	PV1400	73436	55.0
1500	PV1500	73437	58.0
1800	PVHD1800	74598	92.0
2000	PVHD2000	75452	96.0
2100	PVHD2100	74553	100.0
2400	PVHD2400	74555	110.0

*NOTE: V-Tips can be used ONLY on vulcanised belts. P-Type cleaners come standard with bolt tensioners. Shaded items are made to order-contact Flexco customer service.



P-Type® Secondary with V-Tips* Stainless Steel

BELT WIDTH mm	ORDERING NUMBER	ITEM CODE	WT. KG.
450	PV450-S/S	75323	37.0
600	PV600-S/S	75324	38.0
750	PV750-S/S	75325	39.0
900	PV900-S/S	75326	42.0
1050	PV1050-S/S	75327	48.0
1200	PV1200-S/S	75328	52.0
1400	PV1400-S/S	75329	56.0
1500	PV1500-S/S	75330	60.0
1800	PVHD1800-S/S	A1603	95.0
2000	PVHD2000-S/S	A2046	99.0
2100	PVHD2100-S/S	A1604	103.0
2400	PVHD2400-S/S	A1605	114.0

*NOTE: V-Tips can be used ONLY on vulcanised belts. P-Type cleaners come standard with bolt tensioners. Shaded items are made to order-contact Flexco customer service.

Tips Required Per Cleaner Size

BELT WIDTH mm	BLADE COVERAGE mm	V-TIPS REQUIRED
450	450	3
600	600	4
750	750	5
900	900	6
1050	1050	7
1200	1200	8
1400	1350	9
1500	1500	10
1800	1800	12
2000	1950	13
2100	2100	14
2400	2400	16

Product Notes:

- C-Tip: specially formulated tungsten carbide blades to work with mechanical fasteners.
- V-Tip: for use on vulcanised belts only.
- Compact design: fits in small transfer areas and tight chutes.

Stock items (non-shaded) refer to (*) for specific lead time, if not specified, standard lead time applies.

Non-stock items (shaded) please contact Flexco for dispatch options and lead times.

Replacement Parts List

P-Type®
Secondary Cleaner

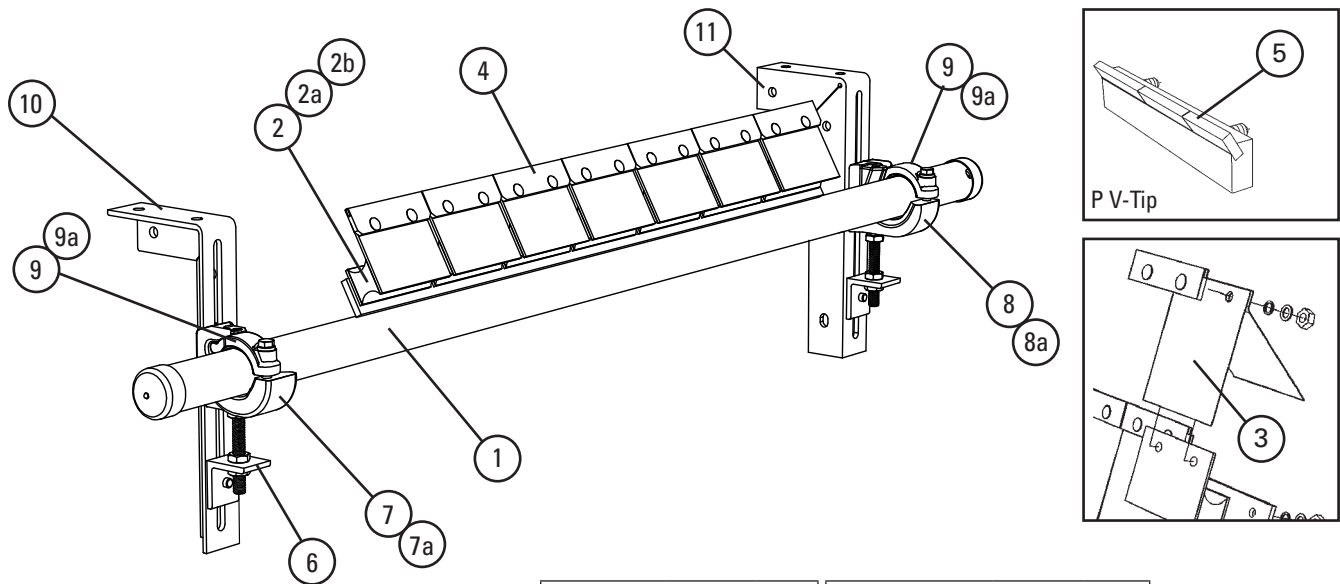

Replacement Parts

REF	DESCRIPTION	POWDER COATED					STAINLESS STEEL		
		BELT WIDTH	POLE LENGTH (MM)	ORDERING NUMBER	ITEM CODE	WT. KG.	ORDERING NUMBER	ITEM CODE	WT. KG.
1	P-Type® Pole 60 mm Pole Diameter	450	1250	PP450	73003	10.0	PP450-S/S	75382	10.0
		600	1350	PP600	73005	11.0	PP600-S/S	75383	11.0
		750	1500	PP750	73007	13.0	PP750-S/S	75384	13.0
		900	1650	PP900	73009	15.0	PP900-S/S	75385	15.0
		1050	1800	PP1050	73011	20.0	PP1050-S/S	75386	21.0
		1200	1950	PP1200	73013	20.0	PP1200-S/S	75387	23.0
	P-Type Pole 73 mm Pole Diameter	1400	2200	PP1400	73015	24.0	PP1400-S/S	75388	25.0
		1500	2350	PP1500	73016	25.0	PP1500-S/S	75389	26.0
		1800	2650	PPHD1800	74597	27.0	PPHD1800-S/S	A1781	28.0
		2000	2850	PPHD2000	74556	31.0	PPHD2000 -S/S	A2120	29.0
		2100	2950	PPHD2100	A2803	38.0	PPHD2100 -S/S	A1613	39.0
		2400	3250	PPHD2400	74557	44.0	PPHD2400 -S/S	A1775	45.0
2	P Cushion			PHA	73626	1.0	PHSC-S/S	73433	1.0
2a	P-Type Powerflex Cushion						PFC-P-S/S	79289	1.9
2n	HD P-Type Cushion			70A	61003	1.7	HDPHSC-S/S	61001	1.9
3	P Polyshield			PPS6	73024	1.0	PSSS	74773	1.0
-	PU150 P-Type Poly Tip FRAS			FRPU150	61742	1.0			
4	C-Tip (for mechanically spliced and vulcanised belts)			CT6	74535	0.4			
5	P V-Tip* (for vulcanised belts only)			PSA150	73156	0.4	PVT6-S/S	75420	0.4
6	Adjusting Bracket Kit* (1ea.)			PAB	75513	0.7	PAB-S/S	75515	0.7
7	Pole Clamp Kit Left* (1ea.) (incl. item 9) (for sizes 450-1200mm)			CCKL	79224	3.1	CCKL-S/S	79226	3.1
8	Pole Clamp Kit Right* (1ea.) (incl. item 9) (for sizes 450-1200mm)			CCKR	79228	3.1	CCKR-S/S	79230	3.1
9	Cradle Clamp Top Strap (1ea.) (for use on L or R Pole Clamp Kit)			CCKTS	79232	0.5	CCKTS-S/S	79234	0.5
10	Mounting Bracket Kit Left			PMBL (left)	75516	3.8	PMBL-S/S (left)	75518	3.8
11	Mounting Bracket Kit Right			PMBL (right)	75519	3.8	PMBL-S/S (right)	75521	3.8
-	Cradle Clamp Mounting Kit* (for sizes 450-1200mm) (incl. 2 ea. item 6, and 1 ea. Items 7, 8, 10 & 11)			CCMK	78919	15.0	CCMK-S/S	78921	15.0
HEAVY-DUTY COMPONENTS									
7a	HD Pole Clamp Kit Left* (1ea.) (incl. item 9a) (for sizes 1400-2400mm)			CCKHDL	79225	4.0	CCKHDL-S/S	79227	4.0
8a	HD Pole Clamp Kit Right* (1ea.) (incl. item 9a) (for sizes 1400-2400mm)			CCKHDR	79229	4.0	CCKHDR-S/S	79231	4.0
9a	HD Cradle Clamp Top Strap (1ea.) (for use on L or R HD Pole Clamp Kit)			CCKHDTS	79233	0.8	CCKHDTS-S/S	73235	0.8
-	HD Cradle Clamp Mounting Kit* (for sizes 1400-2400mm) (incl. 2 ea. item 6, and 1 ea. Items 7, 8, 10 & 11)			CCMKHD	78920	16.7	CCMKHD-S/S	78922	16.7

*Hardware included

Product Ordering Information

R-Type® Reversing Secondary Cleaner

R-Type® Reversing with V-Tips*

BELT WIDTH mm	ORDERING NUMBER	ITEM CODE	WT. KG.
450	RV450	74633	36.0
600	RV600	74634	37.0
750	RV750	74635	38.0
900	RV900	74636	41.0
1050	RV1050	74637	47.0
1200	RV1200	74638	51.0
1400	RV1400	74639	55.0
1500	RV1500	74640	28.0
1800	RVHD1800	74642	92.0
2000	RVHD2000	75463	94.0
2100	RVHD2100	74643	100.0
2400	RVHD2400	74644	110.0

*NOTE: V-Tips can be used ONLY on vulcanised belts. Shaded items are made to order-contact Flexco® customer service.



Stainless Steel R-Type® Reversing with V-Tips*

BELT WIDTH mm	ORDERING NUMBER	ITEM CODE	WT. KG.
450	RV450-S/S	75341	37.0
600	RV600-S/S	75342	38.0
750	RV750-S/S	75343	39.0
900	RV900-S/S	75344	42.0
1050	RV1050-S/S	75345	48.0
1200	RV1200-S/S	75346	57.0
1400	RV1400-S/S	75347	56.0
1500	RV1500-S/S	75348	60.0
1800	RVHD1800-S/S	A1626	95.0
2100	RVHD2100-S/S	A1628	103.0
2400	RVHD2400-S/S	A1610	114.0

*NOTE: V-Tips can be used ONLY on vulcanised belts. Shaded items are made to order-contact Flexco customer service.

Tips Required Per Cleaner Size

BELT WIDTH mm	BLADE COVERAGE mm	C-TIPS OR V-TIPS REQUIRED
450	450	3
600	600	4
750	750	5
900	900	6
1050	1050	7
1200	1200	8
1500	1500	10
1800	1800	12
2000	1950	13
2100	2000	14
2400	2400	16

Product Notes:

- Two-way cushions allow cleaning in both directions.
- Tungsten carbide tips for long wear and superior cleaning.

Stock items (non-shaded) refer to (*) for specific lead time, if not specified, standard lead time applies.

Non-stock items (shaded) please contact Flexco for dispatch options and lead times.

Replacement Parts List

R-Type®
Reversing Secondary Cleaner

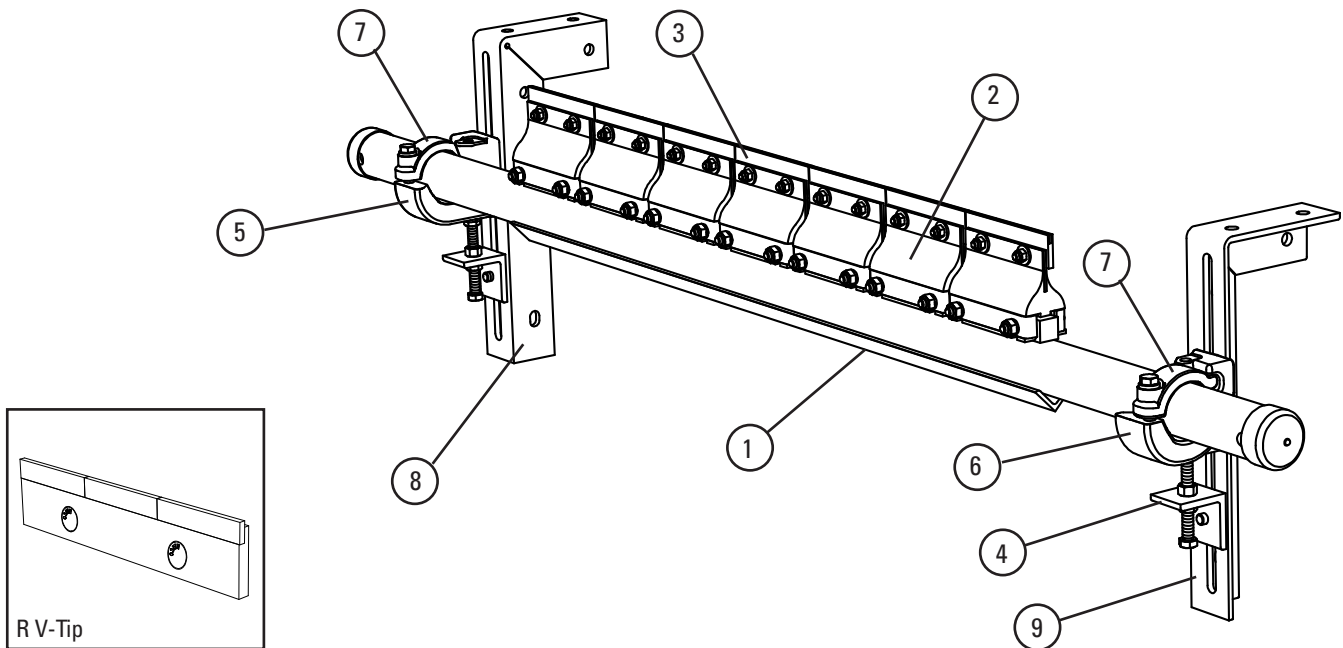

Replacement Parts			POWDER COATED			STAINLESS STEEL			
REF	DESCRIPTION	BELT WIDTH	POLE LENGTH (MM)	ORDERING NUMBER	ITEM CODE	WT. KG.	ORDERING NUMBER	ITEM CODE	WT. KG.
1	R-Type® Pole 60 mm Pole Diameter	450	1250	RP450	74604	10.0	RP450-S/S	75400	10.0
		600	1350	RP600	74605	11.0	RP600-S/S	75401	11.0
		750	1500	RP750	74606	13.0	RP750-S/S	75402	13.0
		900	1650	RP900	74607	15.0	RP900-S/S	75403	15.0
		1050	1800	RP1050	74608	20.0	RP1050-S/S	75404	21.0
		1200	1950	RP1200	74609	22.0	RP1200-S/S	75405	23.0
	R-Type Pole 73 mm Pole Diameter	1400	2200	RP1400	74610	24.0	RP1400-S/S	75406	25.0
		1500	2350	RP1500	74611	25.0	RP1500-S/S	75407	26.0
		1800	2650	RPHD1800	74613	27.0	RPHD1800-S/S	A1575	28.0
		2000	2850	RPHD2000	74614	31.0	RPHD2000-S/S	61270	29.0
		2100	2950	RPHD2100	A2527	38.0	RPHD2100-S/S	A1629	39.0
		2400	3250	RPHD2400	74615	44.0	RPHD2400-S/S	61271	45.0
2	R Cushion			RSA	76249	1.0	RC-S/S	76250	1.0
3	R - V-Tip (for vulcanised belts only)			RSA150	73628	0.4	RVT6-S/S	76205	0.4
-	C-Tip (for mechanically spliced and vulcanised belts)			CT6	74535	0.4			
4	Adjusting Bracket Kit* (1ea.)			PAB	75513	0.7	PAB-S/S	75515	0.7
5	Pole Clamp Kit Left* (1ea.) (incl. item 9) (for sizes 450-1200mm)			CCKL	79224	3.1	CCKL-S/S	79226	3.1
6	Pole Clamp Kit Right* (1ea.) (incl. item 9) (for sizes 450-1200mm)			CCKR	79228	3.1	CCKR-S/S	79230	3.1
7	Cradle Clamp Top Strap (1ea.) (for use on L or R Pole Clamp Kit)			CCKTS	79232	0.5	CCKTS-S/S	79234	0.5
9	Mounting Bracket Kit Left			PMBL (left)	75516	3.8	PMBL-S/S (left)	75518	3.8
9	Mounting Bracket Kit Right			PMBL (right)	75519	3.8	PMBL-S/S (right)	75521	3.8
-	Cradle Clamp Mounting Kit* (for sizes 450-1200mm) (incl. 2 ea. item 6, and 1 ea. Items 7, 8, 10 & 11)			CCMK	78919	15.0	CCMK-S/S	78921	15.0
Heavy-Duty Components									
-	HD Pole Clamp Kit Left* (1ea.) (incl. item 9a) (for sizes 1200-2400mm)			CCKHDL	79225	4.0	CCKHDL-S/S	79227	4.0
-	HD Pole Clamp Kit Right* (1ea.) (incl. item 9a) (for sizes 1200-2400mm)			CCKHDR	79229	4.0	CCKHDR-S/S	79231	4.0
-	HD Cradle Clamp Top Strap (1ea.) (for use on L or R HD Pole Clamp Kit)			CCKHDTS	79233	0.8	CCKHDTS-S/S	73235	0.8
-	HD Cradle Clamp Mounting Kit* (for sizes 1200-2400mm) (incl. 2 ea. item 6, and 1 ea. items 7, 8, 10 & 11)			CCMKHD	78920	16.7	CCMKHD-S/S	78922	16.7

*Hardware included
For additional sizes contact Flexco®.

Stock items (non-shaded) refer to (*) for specific lead time, if not specified, standard lead time applies.

Non-stock items (shaded) please contact Flexco for dispatch options and lead times.

Product Ordering Information

FMS Heavy-Duty Secondary Cleaner (MST Tensioners)



FFMS Secondary with V-Tips (MST)

BELT WIDTH		ORDERING NUMBER	ITEM CODE	WT. KG.
mm	in.			
600	24	FMS-600V	79647	44.4
750	30	FMS-750V	79648	49.3
900	36	FMS-900V	79649	54.3
1050	42	FMS-1050V	79650	59.2
1200	48	FMS-1200V	79651	64.1
1350	54	FMS-1350V	79652	69.0
1500	60	FMS-1500V	79653	73.9
1800	72	FMS-1800V	79654	83.6

FMS Secondary with V-Tips (MST) Stainless Steel

BELT WIDTH		ORDERING NUMBER	ITEM CODE	WT. KG.
mm	in.			
600	24	FMS-600V-S/S	66106	44.9
750	30	FMS-750V-S/S	66107	49.8
900	36	FMS-900V-S/S	66108	54.8
1050	42	FMS-1050V-S/S	66109	59.7
1200	48	FMS-1200V-S/S	66110	64.6
1350	54	FMS-1350V-S/S	66111	69.5
1500	60	FMS-1500V-S/S	66112	74.4
1800	72	FMS-1800V-S/S	66113	84.1

For 2100mm and 2400mm options, please contact Flexco for pricing and availability
Lead time 3 weeks

FMS Secondary with EL V-Tips (MST)

BELT WIDTH		ORDERING NUMBER	ITEM CODE	WT. KG.
mm	in.			
600	24	FMS-600-EL15	65660	44.4
750	30	FMS-750-EL15	65661	49.3
900	36	FMS-900-EL15	65662	54.3
1050	42	FMS-1050-EL15	65663	59.2
1200	48	FMS-1200-EL15	65664	64.1
1350	54	FMS-1350-EL15	65665	69.0
1500	60	FMS-1500-EL15	65666	73.9
1800	72	FMS-1800-EL15	65667	83.6

FMS Secondary with EL V-Tips (MST) Stainless Steel

BELT WIDTH		ORDERING NUMBER	ITEM CODE	WT. KG.
mm	in.			
600	24	FMS-600-EL15-S/S	65670	44.9
750	30	FMS-750-EL15-S/S	65671	49.8
900	36	FMS-900-EL15-S/S	65672	54.8
1050	42	FMS-1050-EL15-S/S	65673	59.7
1200	48	FMS-1200-EL15-S/S	65674	64.6
1350	54	FMS-1350-EL15-S/S	65675	69.5
1500	60	FMS-1500-EL15-S/S	65676	74.4
1800	72	FMS-1800-EL15-S/S	65677	84.1

For 2100mm and 2400mm options, please contact Flexco for pricing and availability
Lead time 3 weeks

Replacement Tips

ORDERING NUMBER	ITEM CODE	WT. KG.
CT6	74535	0.4
RSA150	73628	0.4
RVT6-S/S	76205	0.4
RSA150-EL	61141	0.4

Tips Required Per Cleaner Size

mm	450	600	750	900	1050	1200	1350	1500	1800
in.	18	24	30	36	42	48	54	60	72
C-Tips or V-Tips Required	3	4	5	6	7	8	9	10	12

U.S. Patent No. 6,823,983; 7,093,706

Stock items (non-shaded) refer to (*) for specific lead time, if not specified, standard lead time applies.

Non-stock items (shaded) please contact Flexco for dispatch options and lead times.

Specifications & Guidelines

Pole Length Specifications*

CLEANER SIZE		BLADE WIDTH		POLE LENGTH		MAXIMUM CONVEYOR SPAN	
mm	in.	mm	in.	mm	in.	mm	in.
600	24	600	24	1350	54	1100	44
750	30	750	30	1500	60	1250	50
900	36	900	36	1650	66	1400	56
1050	42	1050	42	1800	72	1550	62
1200	48	1200	48	1950	78	1700	68
1350	54	1350	54	2100	84	1850	74
1500	60	1500	60	2350	96	2100	86
1800	72	1800	72	2650	108	2400	98

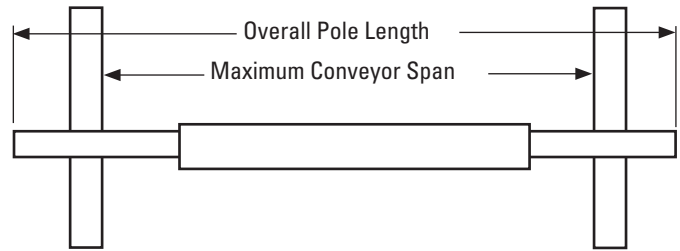

*For special extra long pole length requirements a Pole Extender Kit (#76024) is available that provides 750mm (30") of extended pole length. (page 127).

Pole Diameter - 73mm (2-7/8")

Clearance Guidelines for Installation

HORIZONTAL CLEARANCE REQUIRED		VERTICAL CLEARANCE REQUIRED	
mm	in.	mm	in.
89	3-1/2	245	10

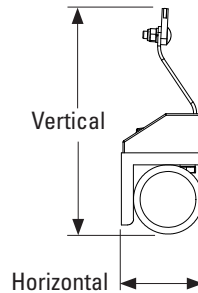

MST Tensioner Spring Length Chart

Blade Width		2 White Springs		2 Silver Springs		2 Black Springs	
mm	in.	mm	in.	mm	in.	mm	in.
600	24	67	2 5/8	86	3 3/8	89	3 1/2
750	30	60	2 3/8	83	3 1/4	86	3 3/8
900	36	54	2 1/8	79	3 1/8	83	3 1/4
1050	42	N/A	N/A	76	3	79	3 1/8
1200	48	N/A	N/A	73	2 7/8	79	3 1/8
1350	54	N/A	N/A	70	2 3/4	76	3
1500	60	N/A	N/A	70	2 3/4	73	2 7/8
1800	72	N/A	N/A	N/A	N/A	70	2 3/4

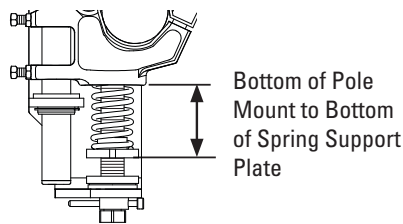

Shading indicates preferred spring option. Measure spring as shown.

Specifications

- Maximum Belt Speed 5 m/s (1000 FPM)
- Temperature Rating -35°C to 82°C (-30°F to 180°F)
- Usable Blade Wear Length..... 9mm (3/8")
- Blade Materials C-Tip: Impact Resistant Tungsten Carbide (works with mechanical fasteners)
..... V-Tip: Long Life Tungsten Carbide (for vulcanized belts only)
- Available for Belt Widths 600 to 2400mm (24" to 96"). Other sizes available upon request
- CEMA Cleaner Rating Class 4

U.S. Patent No. 6,823,983; 7,093,706

Replacement Parts List

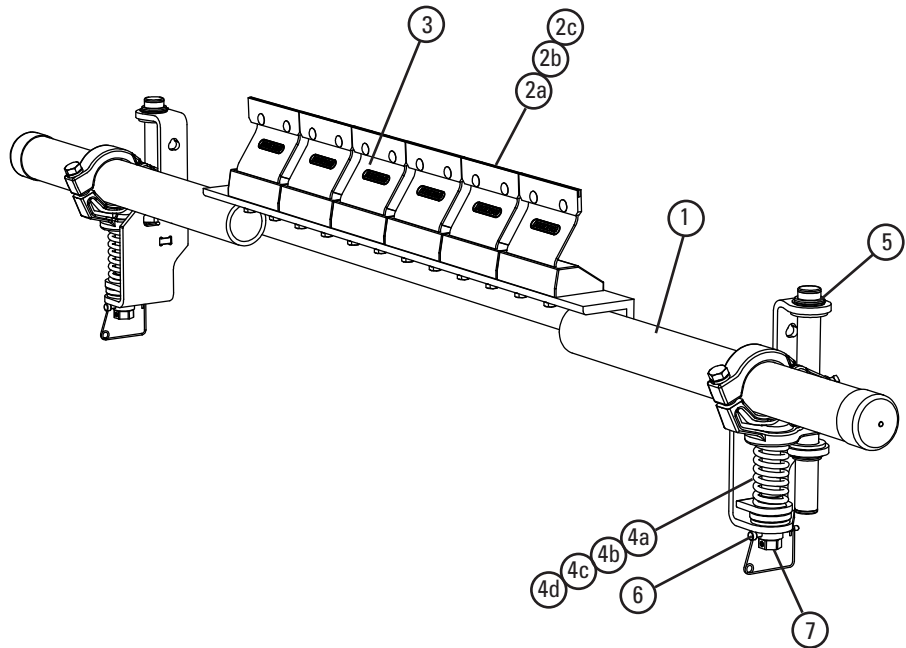

Replacement Parts

REF	DESCRIPTION		ORDERING NUMBER	ITEM CODE	WT. KG.	ORDERING NUMBER	ITEM CODE	WT. KG.
	Belt Width	Pole Length						
1	600	1350	MHS-P600*	77499	21.0	MHS-P600S/S*	77508	21.5
	750	1500	MHS-P750*	77500	23.5	MHS-P750S/S*	77509	24.0
	900	1650	MHS-P900*	77501	26.0	MHS-P900S/S*	77510	26.5
	1050	1800	MHS-P1050*	77502	28.5	MHS-P1050S/S*	77511	29.0
	1200	1950	MHS-P1200*	77527	31.0	MHS-P1200S/S*	77528	31.8
	1350	2100	MHS-P1350*	77503	33.5	MHS-P1350S/S*	77512	34.3
	1500	2350	MHS-P1500*	77504	36.0	MHS-P1500S/S*	77513	36.8
	1800	2650	MHS-P1800*	77505	38.5	MHS-P1800S/S*	77514	39.3
2a	R - V-Tip (for vulcanised belts only)		RSA150	73628	0.4	RVT6-S/S	76205	0.4
2b	C-Tip (for mechanically spliced and vulcanised belts)		CT6	74535	0.4			
2c	Extra Life R - V-Tip (15mm)		RSA150-EL	61141	0.4	RSA150-EL	61141	0.4
3	FMS Cushion Kit		FMSC2	91444	1.9	FMSC2	91444	1.9
4a	Tension Spring - White (1 ea.) for belts 450-750mm		STS-W	75846	0.2	STS-W-S/S	77630	0.2
4b	Tension Spring - Silver (1 ea.) for belts 900-1350mm		STS-S	75843	0.4	STS-S-S/S	77631	0.4
4c	Tension Spring - Black (1 ea.) for belts 1500-1800mm		STS-B	75844	0.5	STS-B-S/S	77632	0.5
4d	Tension Spring - Gold (1 ea.) for belts over 2100mm		STS-G	78142	0.5	STS-G-S/S	79057	0.5
5	MST Bushing Kit (incl. 4 bushings)		MSTBBK	63067	0.1	MSTBBK	63067	0.1
6	MST Lock Pin		MSTLP	64930	0.1	MSTLP	64930	0.1
7	MST Adjusting Mechanism		MSTAM	79435	0.5	MSTAM-S/S	64931	0.5
-	MST HD Tensioner w/White Spring		MSTHD-W	79431	16.7	MSTHD-W-S/S	90181	16.7
-	MST HD Tensioner w/Silver Spring		MSTHD-S	79432	17.0	MSTHD-S-S/S	90182	17.0
-	MST HD Tensioner w/Black Spring		MSTHD-B	79433	17.3	MSTHD-B-S/S	90183	17.3
-	MST HD Tensioner w/Gold Spring		MSTHD-G	63020	17.3	MSTHD-G-S/S	90184	17.3

For 2100mm and 2400mm options, please contact Flexco for pricing and availability

*Lead time 3 weeks

Stock items (non-shaded) refer to (*) for specific lead time, if not specified, standard lead time applies.

Non-stock items (shaded) please contact Flexco for dispatch options and lead times.

U.S. Patent No. 6,823,983; 7,093,706

Product Ordering Information

MHS - MST Heavy Duty Secondary Cleaner

MHS HD with MST Tensioner - Mild Steel

BELT WIDTH	ORDERING NUMBER	ITEM CODE	TIP WIDTH	POLE LENGTH	WT. KG.
mm			mm	mm	
600	MHS-600-MST	64020	600	1350	44.4
750	MHS-750-MST	64021	750	1500	49.3
900	MHS-900-MST	64022	900	1650	54.3
1050	MHS-1050-MST	64023	1050	1800	59.2
1200	MHS-1200-MST	64024	1200	1950	64.1
1350	MHS-1350-MST	64025	1350	2100	69
1500	MHS-1500-MST	64026	1500	2350	73.9
1800	MHS-1800-MST	64027	1800	2650	83.6
2100	MHS-2100-MST	64028	2100	3200	95.7
2400	MHS-2400-MST	64029	2400	3250	103.2

Lead time 3 weeks

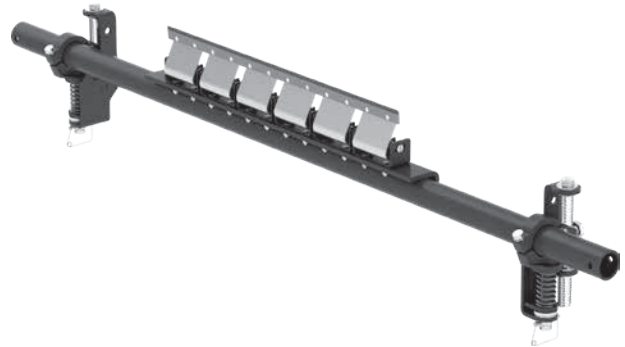

MHS HD with MST Tensioner - Stainless Steel

BELT WIDTH	ORDERING NUMBER	ITEM CODE	TIP WIDTH	POLE LENGTH	WT. KG.
mm			mm	mm	
600	MHS-600-MST-S/S	64030	600	1350	44.9
750	MHS-750-MST-S/S	64031	750	1500	49.8
900	MHS-900-MST-S/S	64032	900	1650	54.8
1050	MHS-1050-MST-S/S	64033	1050	1800	59.7
1200	MHS-1200-MST-S/S	64034	1200	1950	64.6
1350	MHS-1350-MST-S/S	64035	1350	2100	69.5
1500	MHS-1500-MST-S/S	64036	1500	2350	74.4
1800	MHS-1800-MST-S/S	64037	1800	2650	84.1
2100	MHS-2100-MST-S/S	64038	2100	3200	96.2
2400	MHS-2400-MST-S/S	64039	2400	3250	103.7

Lead time 3 weeks

Product Notes:

- Heavy-duty design to deliver maximum cleaning efficiency on the most demanding, abusive beltlines.
- Pole Length: Belt width plus 1350mm (54"). For longer requirements, see accessories - Pole Extender Kit (page 124).
- Patented PowerFlex™ cushion design to maintain continuous blade-to-belt contact and quick relief from passing mechanical splices.
- V-Tips are for vulcanized belts only.
- Visual Blade Tension Check: Measure the tension spring and refer to Spring Length Chart on mounting base for the correct length for best cleaning performance.
- Tensioner: MST Spring Tensioner for self-adjusting tensioning with easy retensioning adjustments.
- To make cleaner installation easier and quicker, see Optional Mounting Kits (page 124).

U.S. Patent No. 6,874,616; 6,823,983; 7,093,706

Stock items (non-shaded) refer to (*) for specific lead time, if not specified, standard lead time applies.

Non-stock items (shaded) please contact Flexco for dispatch options and lead times.

Replacement Parts List

MHS - MST Heavy Duty Secondary Cleaner

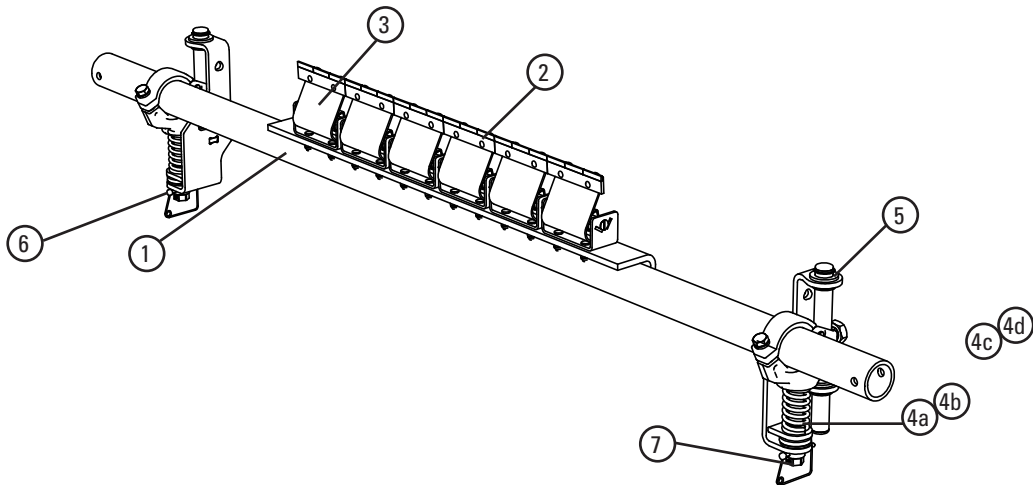

Replacement Parts

REF	DESCRIPTION		MILD STEEL			STAINLESS STEEL		
			ORDERING NUMBER	ITEM CODE	WT. KG.	ORDERING NUMBER	ITEM CODE	WT. KG.
	BELT WIDTH mm	POLE LENGTH mm						
1	600	1350	MHS-P600	77499	23.5	MHS-P600S/S	77508	24.0
	750	1500	MHS-P750	77500	26.0	MHS-P750S/S	77509	26.5
	900	1650	MHS-P900	77501	28.5	MHS-P900S/S	77510	29.0
	1050	1800	MHS-P1050	77502	31.0	MHS-P1050S/S	77511	31.7
	1200	1950	MHS-P1200	77527	33.5	MHS-P1200S/S	77528	34.3
	1350	2100	MHS-P1350	77503	36.0	MHS-P1350S/S	77512	36.8
	1500	2350	MHS-P1500	77504	38.5	MHS-P1500S/S	77513	39.3
	1800	2650	MHS-P1800	77505	43.5	MHS-P1800S/S	77514	44.4
	2100	3200	MHS-P2100	77506	51.0	MHS-P2100S/S	77515	52.0
	2400	3250	MHS-P2400	77507	58.0	MHS-P2400S/S	77516	59.3
2	C-Tip (suits mechanical fastened belt)		CT6	74535	0.4	N/A	N/A	—
	V-Tip (suits vulcanised belt)		RSA150	73628	0.4	RVT6-S/S	76205	0.4
—	Poly Tip Kit		PTK	65746	0.5	PTK	65746	0.5
3	PowerFlex™ Cushion		SPFC	79200	2.0	SPFC-S/S	79201	2.0
4a	Tension Spring - White (1 ea.) for belts 450-750mm		STS-W	75846	0.2	STS-W-S/S	77630	0.2
4b	Tension Spring - Silver (1 ea.) for belts 900-1350mm		STS-S	75843	0.4	STS-S-S/S	77631	0.4
4c	Tension Spring - Black (1 ea.) for belts 1500-1800mm		STS-B	75844	0.5	STS-B-S/S	77632	0.5
4d	Tension Spring - Gold (1 ea.) for belts over 2100mm		STS-G	78142	0.5	STS-G-S/S	79057	0.5
5	MST Bushing Kit (incl. 4 bushings)		MSTBBK	63067	0.1	MSTBBK	63067	0.1
6	MST Lock Pin		MSTLP	64930	0.1	MSTLP	64930	0.1
7	MST Adjustment Mechanism		MSTAM	79435	0.5	MSTAM-S/S	64931	0.5
—	MST HD Tensioner w/White Spring		MSTHD-W	79431	16.7	MSTHD-SS-W	90181	16.7
—	MST HD Tensioner w/Silver Spring		MSTHD-S	79432	17.0	MSTHD-SS-S	90182	17.0
—	MST HD Tensioner w/Black Spring		MSTHD-B	79433	17.3	MSTHD-SS-B	90183	17.3
—	MST HD Tensioner w/Gold Spring		MSTHD-G	63020	17.3	MSTHD-SS-G	90184	17.3

MST Spring Tensioner Selection Chart

CLEANER SIZE	White Spring	Silver Spring	Black Spring	Gold Spring
MHS 450 - 750mm	X			
MHS 900 - 1350mm		X		
MHS 1500 - 1800mm			X	
MHS 1800 - 2400mm				X

Stock items (non-shaded) refer to (*) for specific lead time, if not specified, standard lead time applies.

Non-stock items (shaded) please contact Flexco for dispatch options and lead times.

U.S. Patent No. 6,874,616; 6,823,983; 7,093,706

Replacement Parts List

MHS - MST Heavy Duty Secondary Cleaner

ATV Replacement Parts

REF	DESCRIPTION	ORDERING NUMBER	ITEM CODE	WT. KG.
1	Mounting Bracket LH	PMBL-S/S	75518	3.8
2	Mounting Bracket RH	PMBR-S/S	75521	3.8
3	Air Tensioner Slider	ATV-SLIDE	62425	0.2
4	Air Tension Cradle Blocks 60mm Kit	ATV-MOUNT	62424	2.4
5	Air Tension Cradle Blocks 73mm Kit	ATV-MOUNT	63073	2.4
6	Air Tension Adjusting Angle	ATV-ANGLE	62426	1.0
7	Air Bag	ATV-BAG	62036	0.2
8	Hex Nut S/S	HEX NUT	G1211	0.1
9	Air Line Adaptor	ATV-NIP	62037	0.1
10	PAT Control Box 60psi	PACB60	78683	5.0
11	PAT Control Box 100psi	PACB100	79656	5.0
-	Secondary Air Tension 60mm Complete Kit	ATVK-60	62409	13.0
-	Secondary Air Tension 73mm Complete Kit	ATVK-73	63072	15.0

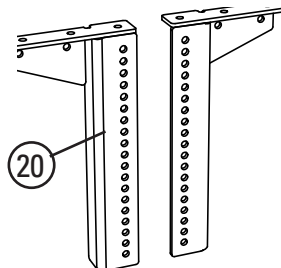
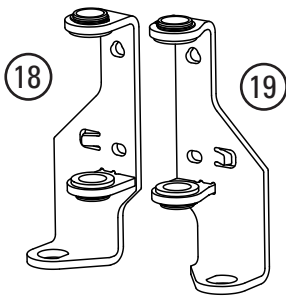
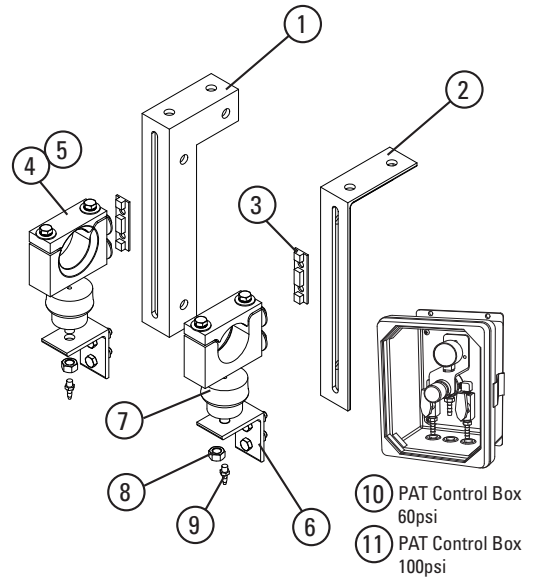

MST Tensioner Replacement Parts

REF	DESCRIPTION	ORDERING NUMBER	ITEM CODE	WT. KG.
18	MST Mounting Bracket LH (incl. bushings)	MST-MBL	79436	2.6
19	MST Mounting Bracket RH (incl. bushings)	MST-MBR	79437	2.6
20	MST Drop Brackets (2)	MSTDB	79434	12.6

*Hardware included
Shaded items are made to order. Lead time 3 weeks.

U.S. Patent No. 6,874,616; 6,823,983; 7,093,706

Stock items (non-shaded) refer to (*) for specific lead time, if not specified, standard lead time applies.
Non-stock items (shaded) please contact Flexco for dispatch options and lead times.

Product Ordering Information

MHS - BT Heavy Duty Secondary Cleaner



MHS HD with Bolt Tensioner (MHS-BT) Mild Steel

BELT WIDTH mm	ORDERING NUMBER	ITEM CODE	TIP WIDTH mm	POLE LENGTH mm	WT. KG.
600	MHS-600BTV	77481	600	1350	44.4
750	MHS-750BTV	77482	750	1500	49.3
900	MHS-900BTV	77483	900	1650	54.3
1050	MHS-1050BTV	77484	1050	1800	59.2
1200	MHS-1200BTV	77525	1200	1950	64.1
1350	MHS-1350BTV	77485	1350	2100	69.0
1500	MHS-1500BTV	77486	1500	2350	73.9
1800	MHS-1800BTV	77487	1800	2650	83.6
2100	MHS-2100BTV	77488	2100	3200	95.7
2400	MHS-2400BTV	77489	2400	3250	103.2

Lead time: 3 weeks

MHS HD with Bolt Tensioner (MHS-BT) Stainless Steel

BELT WIDTH mm	ORDERING NUMBER	ITEM CODE	TIP WIDTH mm	POLE LENGTH mm	WT. KG.
600	MHS-600BTV-S/S	77490	600	1350	45.3
750	MHS-750BTV-S/S	77491	750	1500	50.3
900	MHS-900BTV-S/S	77492	900	1650	55.3
1050	MHS-1050BTV-S/S	77493	1050	1800	60.4
1200	MHS-1200BTV-S/S	77526	1200	1950	65.4
1350	MHS-1350BTV-S/S	77494	1350	2100	70.4
1500	MHS-1500BTV-S/S	77495	1500	2350	75.4
1800	MHS-1800BTV-S/S	77496	1800	2650	85.3
2100	MHS-2100BTV-S/S	77497	2100	3200	97.6
2400	MHS-2400BTV-S/S	77498	2400	3250	105.3

Lead time: 3 weeks

U.S. Patent No. 6,874,616; 6,823,983; 7,093,706

Stock items (non-shaded) refer to (*) for specific lead time, if not specified, standard lead time applies.

Non-stock items (shaded) please contact Flexco for dispatch options and lead times.

Replacement Parts List

MHS - BT Heavy Duty Secondary Cleaner

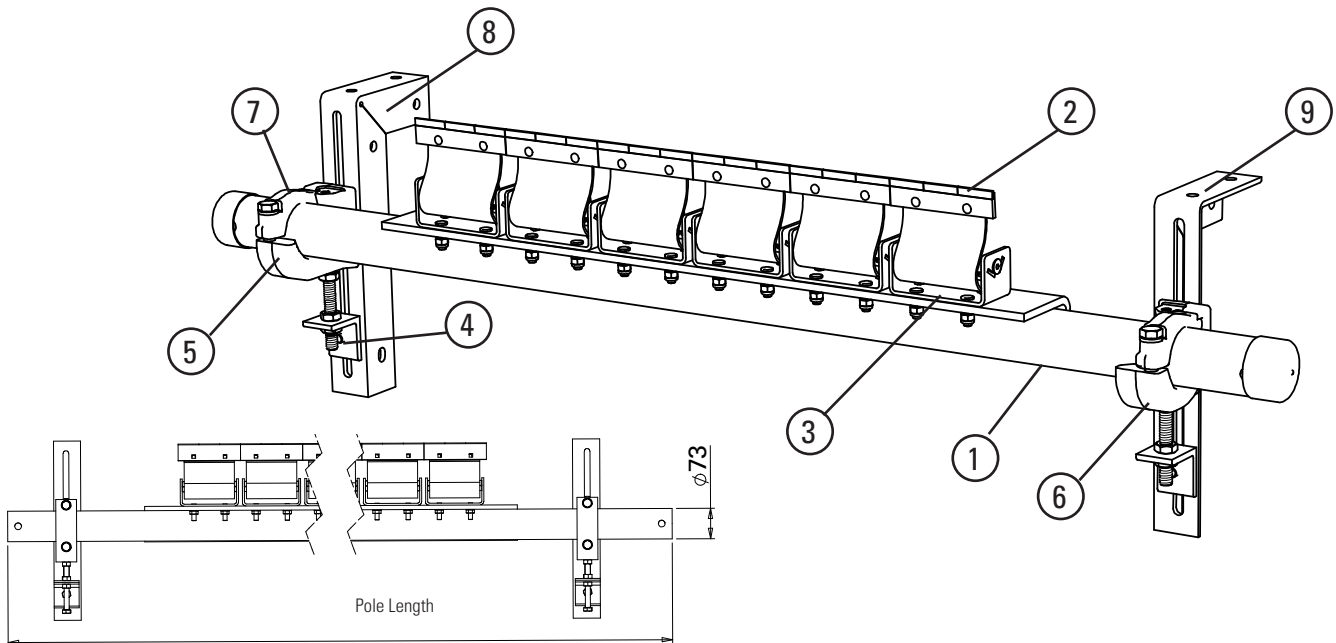

Replacement Parts

REF	DESCRIPTION		MILD STEEL			STAINLESS STEEL		
	BELT WIDTH mm	POLE LENGTH mm	ORDERING NUMBER	ITEM CODE	WT. KG.	ORDERING NUMBER	ITEM CODE	WT. KG.
1	600	1350	MHS-P600*	77499	21.0	MHS-P600S/S*	77508	21.5
	750	1500	MHS-P750*	77500	23.5	MHS-P750S/S*	77509	24.0
	900	1650	MHS-P900*	77501	26.0	MHS-P900S/S*	77510	26.5
	1050	1800	MHS-P1050*	77502	28.5	MHS-P1050S/S*	77511	29.0
	1200	1950	MHS-P1200*	77527	31.0	MHS-P1200S/S*	77528	31.8
	1350	2100	MHS-P1350*	77503	33.5	MHS-P1350S/S*	77512	34.3
	1500	2350	MHS-P1500*	77504	36.0	MHS-P1500S/S*	77513	36.8
	1800	2650	MHS-P1800*	77505	38.5	MHS-P1800S/S*	77514	39.3
	2100	3200	MHS-P2100*	77506	43.5	MHS-P2100S/S*	77515	44.5
	2400	3250	MHS-P2400*	77507	51.0	MHS-P2400S/S*	77516	52.0
2	R - V-Tip (for vulcanised belts only)		RSA150	73628	0.4	RVT6-S/S	76205	0.4
	C-Tip (for mechanically spliced and vulcanised belts)		CT6	74535	0.4			
-	Poly Tip Kit		PTK	65746	0.5	PTK	65746	0.5
3	PowerFlex™ Cushion		SPFC	79200	2.0	SPFC-S/S	79201	2.0
4	Adjusting Bracket Kit* (1ea.)		PAB	75513	0.7	PAB-S/S	75515	0.7
5	HD Pole Clamp Kit Left* (1ea.) (incl. item 9a) (for sizes 1200-2400mm)		CCKHDL	79225	4.0	CCKHDL-S/S	79227	4.0
6	HD Pole Clamp Kit Right* (1ea.) (incl. item 9a) (for sizes 1200-2400mm)		CCKHDR	79229	4.0	CCKHDR-S/S	79231	4.0
7	HD Cradle Clamp Top Strap (1ea.) (for use on L or R HD Pole Clamp Kit)		CCKHDTS	79233	0.8	CCKHDTS-S/S	73235	0.8
8	Mounting Bracket Kit Left		PMBL (left)	75516	3.8	PMBL-S/S (left)	75518	3.8
9	Mounting Bracket Kit Right		PMBL (right)	75519	3.8	PMBL-S/S (right)	75521	3.8
-	HD Cradle Clamp Mounting Kit* (for sizes 1200-2400mm) (incl. 2 ea. item 4, and 1 ea. items 5, 6, 8 & 9)		CCMKHD	78920	16.7	CCMKHD-S/S	78922	16.7

*Lead time: 3 weeks

Stock items (non-shaded) refer to (*) for specific lead time, if not specified, standard lead time applies.

Non-stock items (shaded) please contact Flexco for dispatch options and lead times.

U.S. Patent No. 6,874,616; 6,823,983; 7,093,706

Product Ordering Information

MHS - SST Heavy Duty Secondary Cleaner



MHS HD with SST Spring Tensioner (Complete MHS-FP Cleaner-V Tips)

BELT WIDTH mm	TIP WIDTH mm	POLE LENGTH mm	MILD STEEL			STAINLESS STEEL		
			ORDERING NUMBER	ITEM CODE	WT. KG.	ORDERING NUMBER	ITEM CODE	WT. KG.
600	600	1350	MHS-600FPV	77789	56.8	MHS-600FPV-S/S	77799	58.0
750	750	1500	MHS-750FPV	77790	61.8	MHS-750FPV-S/S	77800	63.0
900	900	1650	MHS-900FPV	77791	67.0	MHS-900FPV-S/S	77801	68.3
1050	1050	1800	MHS-1050FPV	77792	71.8	MHS-1050FPV-S/S	77802	73.3
1200	1200	1950	MHS-1200FPV	77793	76.8	MHS-1200FPV-S/S	77803	78.3
1350	1350	2100	MHS-1350FPV	77794	81.5	MHS-1350FPV-S/S	77804	83.3
1500	1500	2350	MHS-1500FPV	77795	86.5	MHS-1500FPV-S/S	77805	88.3
1800	1800	2650	MHS-1800FPV	77796	96.5	MHS-1800FPV-S/S	77806	98.5
2100	2100	3200	MHS-2100FPV	77797	108.5	MHS-2100FPV-S/S	77807	110.8
2400	2400	3250	MHS-2400FPV	77798	125.0	MHS-2400FPV-S/S	77808	127.0

Lead time: 3 weeks

U.S. Patent No. 6,874,616; 6,823,983; 7,093,706

Stock items (non-shaded) refer to (*) for specific lead time, if not specified, standard lead time applies.

Non-stock items (shaded) please contact Flexco for dispatch options and lead times.

Replacement Parts List

MHS - SST Heavy Duty Secondary Cleaner

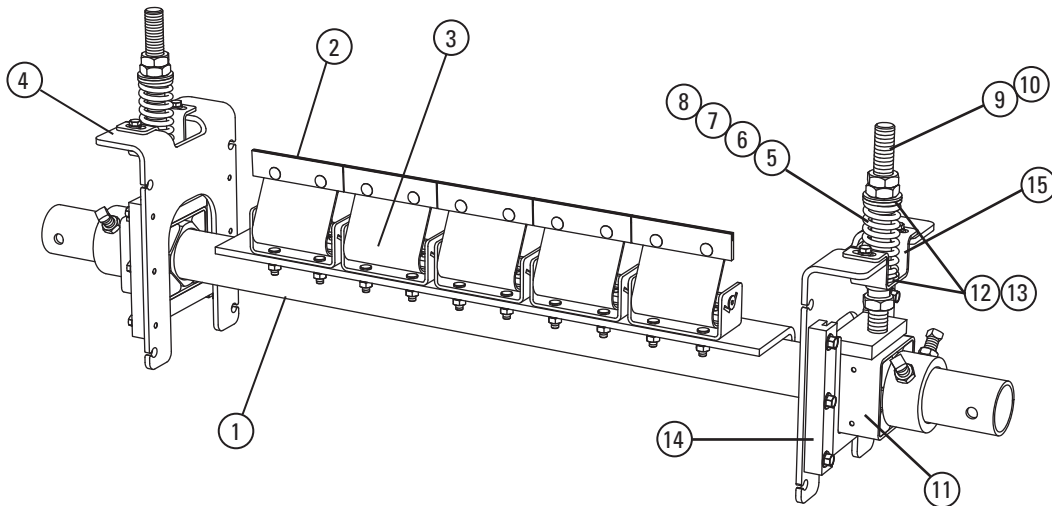

Replacement Parts

REF	DESCRIPTION		MILD STEEL			STAINLESS STEEL		
			ORDERING NUMBER	ITEM CODE	WT. KG.	ORDERING NUMBER	ITEM CODE	WT. KG.
	BELT WIDTH mm	POLE LENGTH mm						
1	600	1350	MHS-P600*	77499	23.5	MHS-P600S/S*	77508	24.0
	750	1500	MHS-P750*	77500	26.0	MHS-P750S/S*	77509	26.5
	900	1650	MHS-P900*	77501	28.5	MHS-P900S/S*	77510	29.0
	1050	1800	MHS-P1050*	77502	31.0	MHS-P1050S/S*	77511	31.7
	1200	1950	MHS-P1200*	77527	33.5	MHS-P1200S/S*	77528	34.3
	1350	2100	MHS-P1350*	77503	36.0	MHS-P1350S/S*	77512	36.8
	1500	2350	MHS-P1500*	77504	38.5	MHS-P1500S/S*	77513	39.3
	1800	2650	MHS-P1800*	77505	43.5	MHS-P1800S/S*	77514	44.4
	2100	3200	MHS-P2100*	77506	51.0	MHS-P2100S/S*	77515	52.0
	2400	3250	MHS-P2400*	77507	58.0	MHS-P2400S/S*	77516	59.3
2	C-Tip (suits mechanical fastened belt)		CT6	74535	0.4	N/A	N/A	—
	V-Tip (suits vulcanised belt)		RSA150	73628	0.4	RVT6-S/S	76205	0.4
-	Poly Tip Kit		PTK	65746	0.5	PTK	65746	0.5
3	PowerFlex™ Cushion		SPFC	79200	2.0	SPFC-S/S	79201	2.0
4	SST HD® Mounting Base Kit* (includes 1 mounting base and 2 slide guides)		SSTHDMK	77870	4.6	STHDMK2-S/S	77634	4.6
5	SST Spring - White (1 ea.) for belts 450-750mm		STS-W	75846	0.2	STS-W-S/S	77630	0.2
6	SST Spring - Silver (1 ea.) for belts 900-1500mm		STS-S	75843	0.4	STS-S-S/S	77631	0.4
7	SST Spring - Black (1 ea.) for belts 1800-2100mm		STS-B	75844	0.5	STS-B-S/S	77632	0.5
8	SST Spring - Gold (1 ea.) for belts over 2100mm		STS-G	78142	0.7			
9	SST Adj Rod Kit* (incl. 1 rod, 2 nuts, 2 bushings, 1 washer) for belts 450-1500 mm		STAK	75847	1.3	STAK	75847	1.3
10	SST HD Adj Rod Kit* (incl. 1 rod, 2 nuts, 2 HD bushings, 1 washer) for belts 1800-2100mm		STAKHD	75892	1.4	STAKHD	75892	1.4
11	SST HD Torsion Pole Mount* (1 ea.)		SSTHDPM	77868	6.8	STHDPM2-S/S	77633	6.8
12	SST Bushing Kit - White/Silver		SSTBK-W	76636	0.1	SSTBK-W	76636	0.1
13	SST Bushing Kit - Black/Gold		SSTBK-B	76637	0.1	SSTBK-B	76637	0.1
14	ST Slide Guide Kit		STGK2	77635	0.5	STGK2	77635	0.5
-	SST HD Cartridge Tensioner - White (includes 1 ea. item 5, 9, 12, 14) for belts 450-750 mm		SST1HDM-W	78517	13.7	SST1HDM-W-S/S	78394	13.7
-	SST HD Cartridge Tensioner - Silver (includes 1 ea. item 6, 9, 12, 14) for belts 900-1500 mm		SST1HDM-S	78518	13.9	SST1HDM-S-S/S	78395	13.9
-	SST HD Cartridge Tensioner - Black (includes 1 ea. item 7, 10, 13, 14) for belts 1800-2100 mm		SST1HDM-B	78519	14.1	SST1HDM-B-S/S	78396	14.1
-	SST HD Cartridge Tensioner - Gold (includes 1 ea. item 8, 10, 13, 14) for belts over 2100 mm		SST1HDM-G	79069	14.3			
15	SST Hat Channel Kit		SSTHK	79070	0.7	SSTHK-S/S	79071	0.7

*Lead time: 3 weeks

U.S. Patent No. 6,874,616; 6,823,983; 7,093,706

Stock items (non-shaded) refer to (*) for specific lead time, if not specified, standard lead time applies.

Non-stock items (shaded) please contact Flexco for dispatch options and lead times.

Replacement Parts List

MHS - SST Heavy Duty Secondary Cleaner

ATV Replacement Parts

REF	DESCRIPTION	ORDERING NUMBER	ITEM CODE	WT. KG.
1	Mounting Bracket LH	PMBL-S/S	75518	3.8
2	Mounting Bracket RH	PMBR-S/S	75521	3.8
3	Air Tensioner Slider	ATV-SLIDE	62425	0.2
4	Air Tension Cradle Blocks 60mm Kit	ATV-MOUNT	62424	2.4
5	Air Tension Cradle Blocks 73mm Kit	ATV-MOUNT	63073	2.4
6	Air Tension Adjusting Angle	ATV-ANGLE	62426	1.0
7	Air Bag	ATV-BAG	62079	0.2
8	Hex Nut S/S	HEX NUT	G1211	0.1
9	Air Line Adaptor	ATV-NIP	62037	0.1
10	PAT Control Box 60psi	PACB60	78683	5.0
11	PAT Control Box 100psi	PACB100	79656	5.0
-	Secondary Air Tension 60mm Complete Kit	ATVK-60	62409	13.0
-	Secondary Air Tension 73mm Complete Kit	ATVK-73	63072	15.0

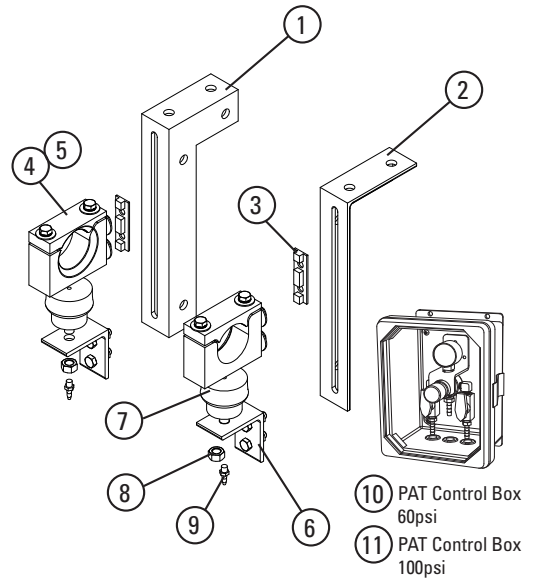

U.S. Patent No. 6,874,616; 6,823,983; 7,093,706

 **Stock items** (non-shaded) refer to (*) for specific lead time, if not specified, standard lead time applies.

 **Non-stock items** (shaded) please contact Flexco for dispatch options and lead times.

Specifications & Guidelines

MHS - SST Heavy Duty Secondary Cleaner

Clearance Guidelines for Installation

HORIZONTAL CLEARANCE REQUIRED mm	VERTICAL CLEARANCE REQUIRED mm
100	238

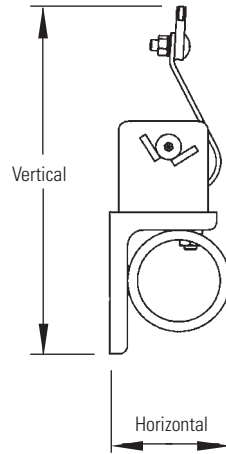

Spring Length Chart for SST Spring Tensioner

BLADE WIDTH mm	WHITE SPRINGS mm	SILVER SPRINGS mm	BLACK SPRINGS mm
450	80	100	N/A
600	70	90	N/A
750	70	90	N/A
900	N/A	90	90
1050	N/A	90	90
1200	N/A	80	90
1350	N/A	80	90
1500	N/A	80	80
1800	N/A	N/A	80
2100	N/A	N/A	70

Shading indicates preferred spring option.

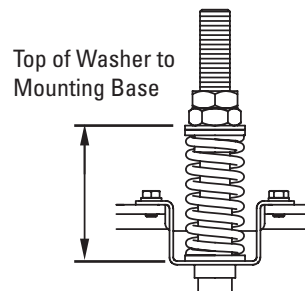

Specifications:

- Maximum Belt SpeedContact Flexco®
- Temperature Rating-35°C to 82°C
- Usable Blade Wear Length.....9 mm
- Blade MaterialsC-Tip: Impact Resistant Tungsten Carbide (works with mechanical fasteners)
V-Tip: Long Life Tungsten Carbide (for vulcanised belts only)

U.S. Patent No. 6,874,616; 6,823,983; 7,093,706

Product Ordering Information

Spring Covers and Tensioner Lock

Spring Covers

ORDERING NUMBER	ITEM CODE	WT. KG.
SPG-CVR-A	77387	0.14
SPG-CVR-B	77388	0.14
SPG-CVR-C	77389	0.14
SPG-CVR-D	77390	0.18
SPG-CVR-E	77391	0.18
SPG-CVR-F	77392	0.14
SPG-CVR-G	77393	0.14
SPG-CVR-H	7741	0.14

Includes 1 spring cover

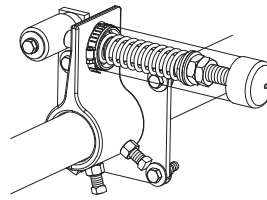
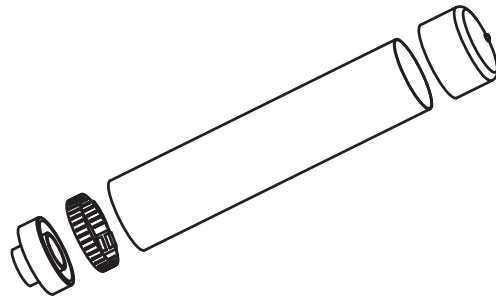

Spring cover on Primary Cleaner tensioner

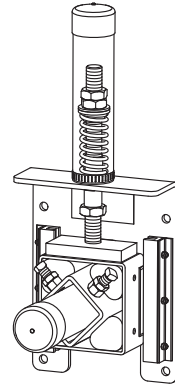

Spring cover on Secondary cleaner tensioner

Tensioner Lock

Designed to prevent tampering or unauthorized retensioning of the cleaner.

ORDERING NUMBER	ITEM CODE	WT. KG.
TEN-LOCK-KIT	77443	0.18

*For MSP, MMP, MHP, MHCP, H-Type® Primary Cleaner and MSS, MHS, MDWS Secondary Cleaners

Includes 1 tensioner lock

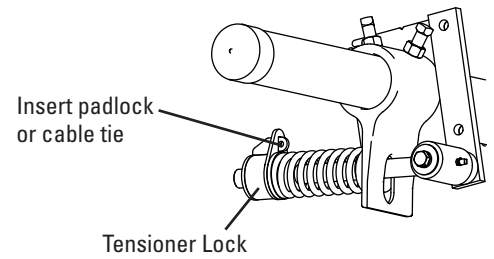
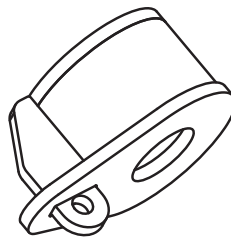

Tensioner Lock

(Primary Cleaner tensioner shown)

U.S. Patent No. D664,829

 **Stock items** (non-shaded) refer to (*) for specific lead time, if not specified, standard lead time applies.

 **Non-stock items** (shaded) please contact Flexco for dispatch options and lead times.

Product Ordering Information

P-Type® SAC Secondary Cleaner with Service Advantage Cartridge™

P-Type® SAC Secondary with V-Tips*

BELT WIDTH mm	ORDERING NUMBER	ITEM CODE	WT. KG.
600	PV600-SAC	78020	62.3
750	PV750-SAC	78021	68.4
900	PV900-SAC	78022	74.4
1050	PV1050-SAC	78023	80.4
1200	PV1200-SAC	78024	86.4
1350	PV1350-SAC	78025	92.5
1500	PV1500-SAC	78026	98.5
1800	PV1800-SAC	78027	110.6
1500	PV1500-2SAC	78028	137.8
1800	PV1800-2SAC	78029	150.0
2100	PV2100-2SAC	78030	162.5
2400	PV2400-2SAC	78031	174.7
3000	PV3000-2SAC	78032	201.3

*NOTE: V-Tips can be used ONLY on vulcanised belts.

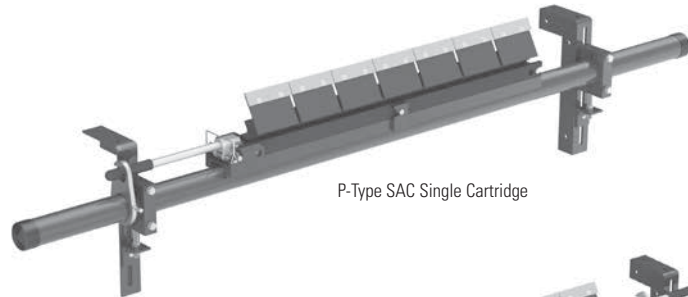

P-Type SAC Single Cartridge

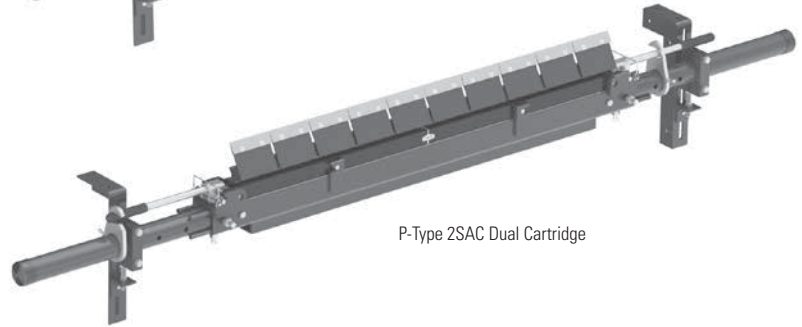

P-Type 2SAC Dual Cartridge

P-Type SAC Stainless Steel Secondary with V-Tips*

BELT WIDTH mm	ORDERING NUMBER	ITEM CODE	WT. KG.
600	PV600-SAC-S/S	78329	62.3
750	PV750-SAC-S/S	78330	68.4
900	PV900-SAC-S/S	78331	74.4
1050	PV1050-SAC-S/S	78332	80.4
1200	PV1200-SAC-S/S	78333	86.4
1350	PV1350-SAC-S/S	78334	92.5
1500	PV1500-SAC-S/S	78335	98.5
1800	PV1800-SAC-S/S	78336	110.6
1500	PV1500-2SAC-S/S	78337	137.8
1800	PV1800-2SAC-S/S	78338	150.0
1950	PV1950-2SAC-S/S	78656	156.2
2100	PV2100-2SAC-S/S	78339	162.5
2400	PV2400-2SAC-S/S	78340	174.7
3000	PV3000-2SAC-S/S	78341	201.3

*NOTE: V-Tips can be used ONLY on vulcanised belts.

Replacement Tips

ORDERING NUMBER	ITEM CODE	WT. KG.
CT6 (C-Tip)	74535	0.4
PSA150 (V-Tip)	73156	0.4

Tips Required Per Cleaner Size

BELT WIDTH mm	BLADE COVERAGE mm	V-TIPS REQUIRED
600	600	4
750	750	5
900	900	6
1050	1050	7
1200	1200	8
1350	1350	9
1500	1500	10
1800	1800	12
2100	2100	14
2400	2400	16
3000	3000	20

Product Notes:

- Patent-pending Service Advantage Cartridge™ allows for easy removal in even the dirtiest conditions.
- Pole Length: Belt width plus 1350 mm (single cartridge cleaners); Belt width plus 1500 mm (dual cartridge cleaners).
- Tips are set at a non-aggressive 70° angle to give quick relief for passing mechanical splices.
- C-Tips are for mechanically fastened or vulcanised belts. V-Tips are for vulcanised belts only.
- Tensioner mounting brackets included for fast and easy installation.
- Cartridge Removal Kit included for easy removal of the cartridge.

U.S. Patent No. 7,987,966; 8,757,360; 8,312,986; 8,640,856; 9,090,405; 9,085,419

Stock items (non-shaded) refer to (*) for specific lead time, if not specified, standard lead time applies.

Non-stock items (shaded) please contact Flexco for dispatch options and lead times.

Product Ordering Information

P-Type® SAC
Secondary Cleaner
with Service Advantage Cartridge™

P-Type® SAC Cartridge Kits with V-Tips*

BELT WIDTH mm	ORDERING NUMBER	ITEM CODE	WT. KG.
600	P-CARK-V24/600	78080	11.4
750	P-CARK-V30/750	78081	13.6
900	P-CARK-V36/900	78082	15.7
1050	P-CARK-V42/1050	78083	17.9
1200	P-CARK-V48/1200	78084	20.0
1350	P-CARK-V54/1350	78085	22.2
1500	P-CARK-V60/1500	78086	24.4
1800	P-CARK-V72/1800	78087	28.7
1500	P-CARK2-V60/1500	78093	39.7
1800	P-CARK2-V72/1800	78094	46.4
2100	P-CARK2-V84/2100	78095	53.2
2400	P-CARK2-V96/2400	78096	59.9
3000	P-CARK2-V120/3000	78097	73.6

*NOTE: V-Tips can be used ONLY on vulcanised belts.

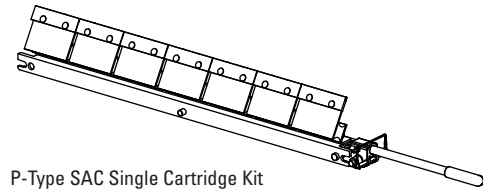

P-Type SAC Single Cartridge Kit

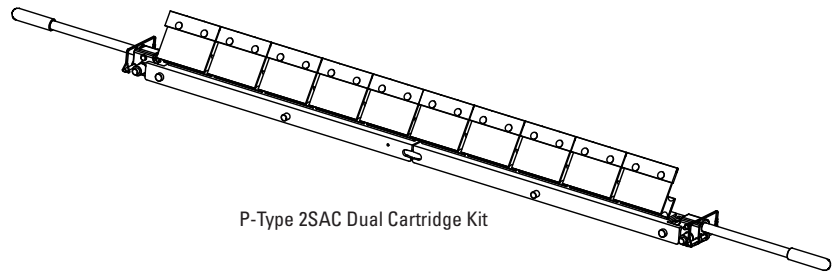

P-Type 2SAC Dual Cartridge Kit

P-Type SAC Stainless Steel Cartridge Kits with V-Tips*

BELT WIDTH mm	ORDERING NUMBER	ITEM CODE	WT. KG.
600	P-CARK-V24/600-S/S PVECKS/S	82815	11.4
750	P-CARK-V30/750-S/S PVECKS/S	82816	13.6
900	P-CARK-V36/900-S/S PVECKS/S	82817	15.7
1050	P-CARK-V42/1050-S/S PVECKS/S	82818	17.9
1200	P-CARK-V48/1200-S/S PVECKS/S	82819	20.0
1350	P-CARK-V54/1350-S/S PVECKS/S	82820	22.2
1500	P-CARK-V60/1500-S/S PVECKS/S	82821	24.4
1800	P-CARK-V72/1800-S/S PVECKS/S	82822	28.7
1500	P-CARK2-V60/1500-S/S PV2ECKSS	82823	39.7
1800	P-CARK2-V72/1800-S/S PV2ECKSS	82824	46.4
2000	P-CARK2-V78/1950-S/S PV2ECKSS	82876	49.2
2100	P-CARK2-V84/2100-S/S PV2ECKSS	82825	53.2
2400	P-CARK2-V96/2400-S/S PV2ECKSS	82826	59.9
3000	P-CARK2-V120/3000-S/S PV2ECKSS	82827	73.6

*NOTE: V-Tips can be used ONLY on vulcanised belts.

U.S. Patent No. 7,987,966; 8,757,360; 8,312,986;
 8,640,856; 9,090,405; 9,085,419

Stock items (non-shaded) refer to (*) for specific lead time, if not specified, standard lead time applies.

Non-stock items (shaded) please contact Flexco for dispatch options and lead times.

Replacement Parts List

P-Type® SAC (Mild Steel) Secondary Cleaner with Service Advantage Cartridge™

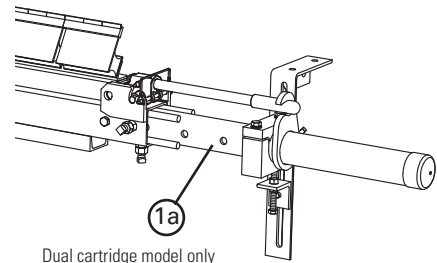
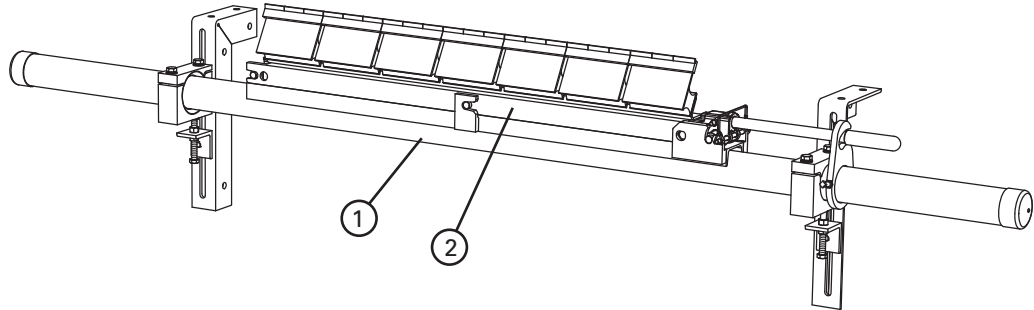

Replacement Parts

REF	DESCRIPTION	ORDERING NUMBER	ITEM CODE	WT. KG.
1	SAC Cartridge Pole 600 mm	SACPL-24/600	77887	29.7
	SAC Cartridge Pole 750 mm	SACPL-30/750	77888	32.3
	SAC Cartridge Pole 900 mm	SACPL-36/900	77889	35.0
	SAC Cartridge Pole 1050 mm	SACPL-42/1050	77890	37.6
	SAC Cartridge Pole 1200 mm	SACPL-48/1200	77891	40.3
	SAC Cartridge Pole 1350 mm	SACPL-54/1350	77892	42.9
	SAC Cartridge Pole 1500 mm	SACPL-60/1500	77893	45.6
	SAC Cartridge Pole 1800 mm	SACPL-72/1800	77894	50.9
	SAC Cartridge Center Pole 1500 mm (Dual)	SACPL2-60/1500	77895	35.1
	SAC Cartridge Center Pole 1800 mm (Dual)	SACPL2-72/1800	77896	40.6
	SAC Cartridge Center Pole 2100 mm (Dual)	SACPL2-84/2100	77897	46.2
	SAC Cartridge Center Pole 2400 mm (Dual)	SACPL2-96/2400	77898	51.8
	SAC Cartridge Center Pole 3000 mm (Dual)	SACPL2-120/3000	77899	64.5
	1a	Extender Pole (for use with Dual Cartridge Center Pole)	MHP-EP	76392
2	SAC Repl Cartridge S/S 600 mm	CART-24/600-S/S	78576	4.5
	SAC Repl Cartridge S/S 750 mm	CART-30/750-S/S	78577	5.6
	SAC Repl Cartridge S/S 900 mm	CART-36/900-S/S	78578	6.7
	SAC Repl Cartridge S/S 1050 mm	CART-42/1050-S/S	78579	7.8
	SAC Repl Cartridge S/S 1200 mm	CART-48/1200-S/S	78580	8.9
	SAC Repl Cartridge S/S 1350 mm	CART-54/1350-S/S	78581	10.0
	SAC Repl Cartridge S/S 1500 mm	CART-60/1500-S/S	78582	11.3
	SAC Repl Cartridge S/S 1800 mm	CART-72/1800-S/S	78583	13.5
	SAC Repl Cartridge S/S 1500 mm (Dual)	CART2-60/1500-S/S	78584	11.2
	SAC Repl Cartridge S/S 1800 mm (Dual)	CART2-72/1800-S/S	78585	13.4
	SAC Repl Cartridge S/S 1950 mm (Dual)	CART2-78/1950-S/S	78635	14.5
	SAC Repl Cartridge S/S 2100 mm (Dual)	CART2-84/2100-S/S	78586	15.6
	SAC Repl Cartridge S/S 2400 mm (Dual)	CART2-96/2400-S/S	78587	17.8
	SAC Repl Cartridge S/S 3000 mm (Dual)	CART2-120/3000-S/S	78588	22.6

U.S. Patent No. 7,987,966; 8,757,360; 8,312,986;
8,640,856; 9,090,405; 9,085,419

Stock items (non-shaded) refer to (*) for specific lead time, if not specified, standard lead time applies.
Non-stock items (shaded) please contact Flexco for dispatch options and lead times.

Replacement Parts List

P-Type® SAC (Mild Steel) Secondary Cleaner with Service Advantage Cartridge™

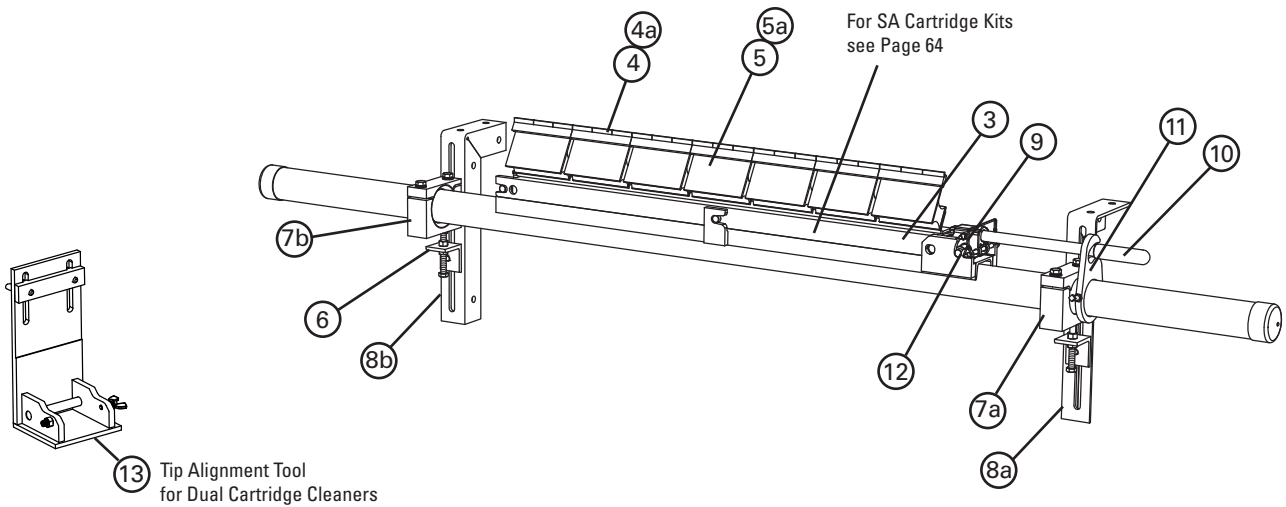

Replacement Parts (Continued)

REF	DESCRIPTION	ORDERING NUMBER	ITEM CODE	WT. KG.
3	SAC Cartridge P-Type® Adapter Plate 600 mm	PCAP-24/600	77913	2.1
	SAC Cartridge P-Type Adapter Plate 750 mm §	PCAP-30/750	77914	2.8
	SAC Cartridge P-Type Adapter Plate 900 mm §	PCAP-36/900	77915	3.3
	SAC Cartridge P-Type Adapter Plate 1050 mm §	PCAP-42/1050	77916	3.9
	SAC Cartridge P-Type Adapter Plate 1200 mm §	PCAP-48/1200	77917	4.4
	SAC Cartridge P-Type Adapter Plate 1350 mm	PCAP-54/1350	77918	5.0
	SAC Cartridge P-Type Adapter Plate 1500 mm §	PCAP-60/1500	77919	5.6
	SAC Cartridge P-Type Adapter Plate 1800 mm	PCAP-72/1800	77920	6.7
4	C-Tip*	CT6	74535	0.4
4a	P V-Tip* (for vulcanised belts only)	PSA150	73156	0.4
5	Cushion*	PHA	73626	1.6
5a	HD P-Type Cushion	70A	61003	1.0
6	P/R Adjusting Bracket	PAB	75513	0.4
7a	Cradle Clamp Block RH	SMR-CCB-R73	A2843	1.2
7b	Cradle Clamp Block LH	SMR-CCB-L73	A2842	1.2
8a	Mounting Bracket Kit, RH	PMBR	75519	3.8
8b	Mounting Bracket Kit, LH	PMBL	75516	3.8
9	SAC Removal Knuckle	SACRKN	77882	1.5
10	SAC Removal Handle	SACRH	77883	1.4
11	SAC Handle Lock Plate	SACRHL	77884	0.8
12	Knuckle Retainer Pin	SACKRP	77885	0.1
-	SAC Removal Kit (includes 1 ea. items 9,10,11,12)	SACRKT	77886	4.1
13	SAC Cartridge Tip Alignment Tool (Dual)	SAC2-TIP-TL	77866	1.1
-	Cradle Clamp Heavy-Duty Mounting Kit (incl. 2 ea. item 6; incl. 1 ea. items 7a, 7b, 8a, 8b)	CRHMK	62400	10.8

§ If using a dual cartridge, please take the cleaner size and divide by two. That dimension is the size of the brackets needed for conversion to a P-Type cleaner.

U.S. Patent No. 7,987,966; 8,757,360; 8,312,986;
8,640,856; 9,090,405; 9,085,419

Stock items (non-shaded) refer to (*) for specific lead time, if not specified, standard lead time applies.

Non-stock items (shaded) please contact Flexco for dispatch options and lead times.

Replacement Parts List

P-Type® SAC (Stainless Steel) Secondary Cleaner with Service Advantage Cartridge™

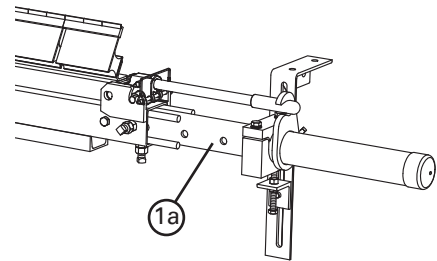
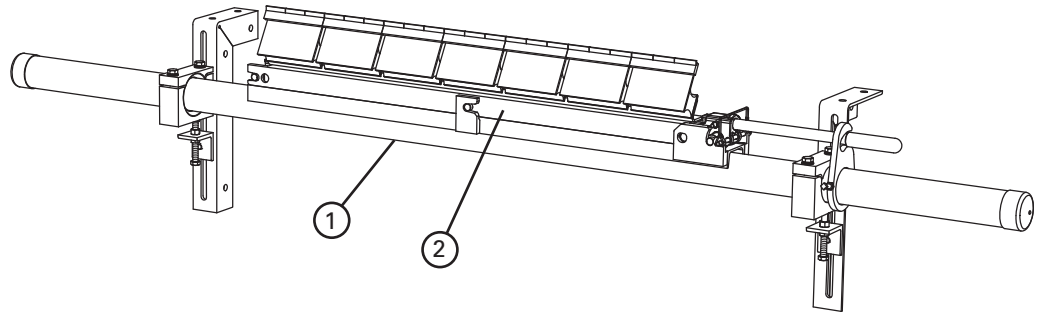

Dual cartridge model only

Replacement Parts

REF	DESCRIPTION	ORDERING NUMBER	ITEM CODE	WT. KG.
1	SAC S/S Cartridge Pole 600 mm	SACPL-24/600-S/S	78371	29.7
	SAC S/S Cartridge Pole 750 mm	SACPL-30/750-S/S	78372	32.3
	SAC S/S Cartridge Pole 900 mm	SACPL-36/900-S/S	78373	35.0
	SAC S/S Cartridge Pole 1050 mm	SACPL-42/1050-S/S	78374	37.6
	SAC S/S Cartridge Pole 1200 mm	SACPL-48/1200-S/S	78375	40.3
	SAC S/S Cartridge Pole 1350 mm	SACPL-54/1350-S/S	78376	42.9
	SAC S/S Cartridge Pole 1500 mm	SACPL-60/1500-S/S	78377	45.6
	SAC S/S Cartridge Pole 1800 mm	SACPL-72/1800-S/S	78378	50.9
	SAC S/S Cartridge Center Pole 1500 mm (Dual)	SACPL2-60/1500-S/S	78379	35.1
	SAC S/S Cartridge Center Pole 1800 mm (Dual)	SACPL2-72/1800-S/S	78380	40.6
	SAC S/S Cartridge Center Pole 1950 mm (Dual)	SACPL2-78/1950-S/S	78642	43.9
	SAC S/S Cartridge Center Pole 2100 mm (Dual)	SACPL2-84/2100-S/S	78381	46.2
	SAC S/S Cartridge Center Pole 2400 mm (Dual)	SACPL2-96/2400-S/S	78382	51.8
	SAC S/S Cartridge Center Pole 3000 mm (Dual)	SACPL2-120/3000-S/S	78383	64.5
1a	S/S Extender Pole (for use with S/S Dual Cartridge Center Pole)	MHP-EP-S/S	77599	24.5
2	SAC Repl Cartridge S/S 600 mm	CART-24/600-S/S	78576	4.5
	SAC Repl Cartridge S/S 750 mm	CART-30/750-S/S	78577	5.6
	SAC Repl Cartridge S/S 900 mm	CART-36/900-S/S	78578	6.7
	SAC Repl Cartridge S/S 1050 mm	CART-42/1050-S/S	78579	7.8
	SAC Repl Cartridge S/S 1200 mm	CART-48/1200-S/S	78580	8.9
	SAC Repl Cartridge S/S 1350 mm	CART-54/1350-S/S	78581	10.0
	SAC Repl Cartridge S/S 1500 mm	CART-60/1500-S/S	78582	11.3
	SAC Repl Cartridge S/S 1800 mm	CART-72/1800-S/S	78583	13.5
	SAC Repl Cartridge S/S 1500 mm (Dual)	CART2-60/1500-S/S	78584	11.2
	SAC Repl Cartridge S/S 1800 mm (Dual)	CART2-72/1800-S/S	78585	13.4
	SAC Repl Cartridge S/S 1950 mm (Dual)	CART2-78/1950-S/S	78635	14.5
	SAC Repl Cartridge S/S 2100 mm (Dual)	CART2-84/2100-S/S	78586	15.6
	SAC Repl Cartridge S/S 2400 mm (Dual)	CART2-96/2400-S/S	78587	17.8
	SAC Repl Cartridge S/S 3000 mm (Dual)	CART2-120/3000-S/S	78588	22.6

U.S. Patent No. 7,987,966; 8,757,360; 8,312,986; 8,640,856; 9,090,405; 9,085,419

Stock items (non-shaded) refer to (*) for specific lead time, if not specified, standard lead time applies.

Non-stock items (shaded) please contact Flexco for dispatch options and lead times.

Replacement Parts List

P-Type® SAC (Stainless Steel) Secondary Cleaner with Service Advantage Cartridge™

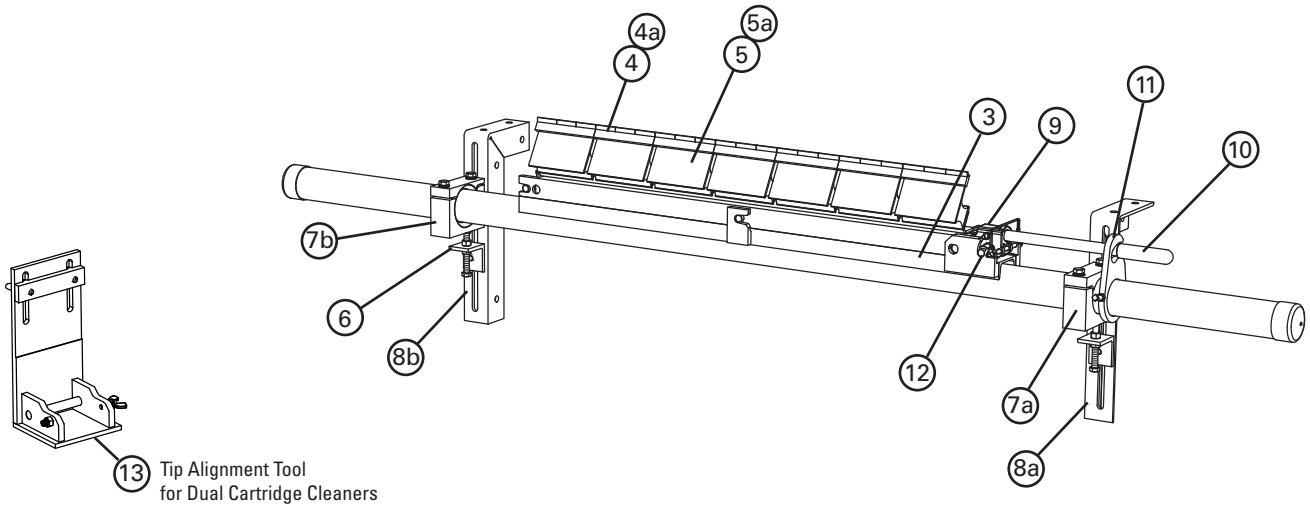

Replacement Parts (Continued)

REF	DESCRIPTION	ORDERING NUMBER	ITEM CODE	WT. KG.
3	SAC Cartridge P-Type® S/S Adapter Plate 600 mm	PCAP-24/600-S/S	78355	2.1
	SAC Cartridge P-Type S/S Adapter Plate 750 mm §	PCAP-30/750-S/S	78356	2.8
	SAC Cartridge P-Type S/S Adapter Plate 900 mm §	PCAP-36/900-S/S	78357	3.3
	SAC Cartridge P-Type S/S Adapter Plate 1050 mm §	PCAP-42/1050-S/S	78358	3.9
	SAC Cartridge P-Type S/S Adapter Plate 1200 mm §	PCAP-48/1200-S/S	78359	4.4
	SAC Cartridge P-Type S/S Adapter Plate 1350 mm	PCAP-54/1350-S/S	78360	5.0
	SAC Cartridge P-Type S/S Adapter Plate 1500 mm §	PCAP-60/1500-S/S	78361	5.6
	SAC Cartridge P-Type S/S Adapter Plate 1800 mm	PCAP-72/1800-S/S	78362	6.7
4	C-Tip	CT6	74535	0.4
4a	S/S P V-Tip	PVT6-S/S	75420	0.4
5	S/S P Cushion*	PHSC-S/S	73433	1.6
5a	HD P-Type Cushion S/S	HDPHSC-S/S	61001	1.0
6	P/R Adjusting Bracket S/S	PAB-S/S	75515	0.4
7a	Cradle Clamp LH S/S CRDLBLK-LH	CRDLBLK-RH-S/S	A2825	1.2
7b	Cradle Clamp RH S/S CRDLBLK-RH	CRDLBLK-LH-S/S	A2826	1.2
8a	Mounting Bracket Kit RH S/S	PMBR-S/S	75521	3.8
8b	Mounting Bracket Kit LH S/S	PMBL-S/S	75518	3.8
9	SAC Removal Knuckle	SACRKN	77882	1.5
10	SAC Removal Handle S/S	SACRH-S/S	78397	1.4
11	SAC Handle Lock Plate S/S	SACRHL-S/S	78398	0.8
12	Knuckle Retainer Pin S/S	SACKRP-S/S	78399	0.1
-	SAC Removal Kit S/S (includes 1 ea. items 9,10,11,12)	SACRKT-S/S	78401	4.1
13	SAC Cartridge Tip Alignment Tool (Dual)	SAC2-TIP-TL	77866	1.1
-	Cradle Clamp Stainless Steel Heavy-Duty Mounting Kit (incl. 2 ea. item 6; incl. 1 ea. items 7a, 7b, 8a, 8b)	CRHMK-S/S	62095	10.8

§ If using a dual cartridge, please take the cleaner size and divide by two. That dimension is the size of the brackets needed for conversion to a P-Type cleaner.

U.S. Patent No. 7,987,966; 8,757,360; 8,312,986; 8,640,856; 9,090,405; 9,085,419

Stock items (non-shaded) refer to (*) for specific lead time, if not specified, standard lead time applies.

Non-stock items (shaded) please contact Flexco for dispatch options and lead times.

Specifications & Guidelines

P-Type® SAC
Secondary Cleaner
with Service Advantage Cartridge™

Pole Length Specifications*

VERSION	CLEANER SIZE mm	BLADE WIDTH mm	POLE LENGTH mm	MAXIMUM CONVEYOR SPAN mm
Single	600	600	1950	1650
	750	750	2100	1800
	900	900	2250	1950
	1050	1050	2400	2100
	1200	1200	2550	2250
	1350	1350	2700	2400
	1500	1500	2850	2550
	1800	1800	3150	2850
Dual	1500	1500	3000	2700
	1800	1800	3300	3000
	2100	2100	3600	3300
	2400	2400 </td <td>3900</td> <td>3600</td>	3900	3600
	3000	3000	4500	4200

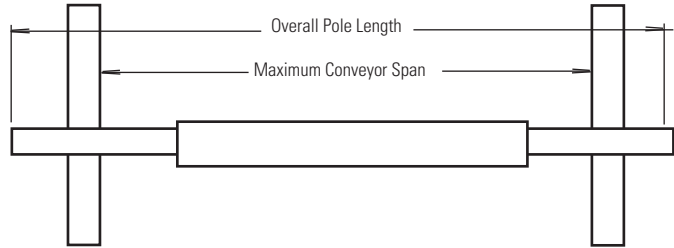

*For special extra long pole length requirements a Pole Extender Kit (#76024) is available that provides 750 mm of extended pole length.
 Pole Diameter - 73 mm

Clearance Guidelines for Installation

VERSION	HORIZONTAL CLEARANCE REQUIRED mm	VERTICAL CLEARANCE REQUIRED mm
Single	114	267
Dual	114	311

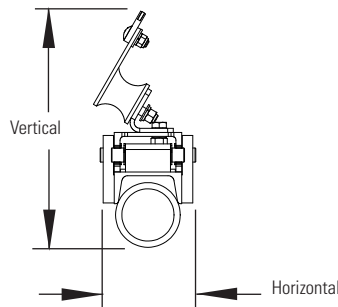

Specifications:

- Maximum Belt Speed5M/sec
- Temperature Rating-35°C to 82°C
- Usable Blade Wear Length.....9 mm
- Blade MaterialsC-Tip: Impact Resistant Tungsten Carbide (works with mechanical fasteners)
 V-Tip: Long Life Tungsten Carbide (for vulcanised belts only)
- Available for Belt Widths600 to 3000 mm. Other sizes available upon request.

U.S. Patent No. 7,987,966; 8,757,360; 8,312,986;
 8,640,856; 9,007,985; 9,083,419; Int Pending

Product Ordering Information

R-Type® SAC Secondary Cleaner with Service Advantage Cartridge™

R-Type® SAC Secondary with V-Tips*

BELT WIDTH mm	ORDERING NUMBER	ITEM CODE	WT. KG.
600	RV600-SAC	78033	58.3
750	RV750-SAC	78034	63.3
900	RV900-SAC	78035	68.3
1050	RV1050-SAC	78036	73.3
1200	RV1200-SAC	78037	78.3
1350	RV1350-SAC	78038	83.3
1500	RV1500-SAC	78039	88.4
1800	RV1800-SAC	78040	98.3
1500	RV1500-2SAC	78041	107.5
1800	RV1800-2SAC	78042	117.7
2100	RV2100-2SAC	78043	127.8
2400	RV2400-2SAC	78044	138.0
3000	RV3000-2SAC	78045	160.6

*NOTE: V-Tips can be used ONLY on vulcanised belts.

R-Type SAC Stainless Steel Secondary with V-Tips*

BELT WIDTH mm	ORDERING NUMBER	ITEM CODE	WT. KG.
600	RV600-SAC-S/S	78342	58.3
750	RV750-SAC-S/S	78343	63.3
900	RV900-SAC-S/S	78344	68.3
1050	RV1050-SAC-S/S	78345	73.3
1200	RV1200-SAC-S/S	78346	78.3
1350	RV1350-SAC-S/S	78347	83.3
1500	RV1500-SAC-S/S	78348	88.4
1800	RV1800-SAC-S/S	78349	98.3
1500	RV1500-2SAC-S/S	78350	107.5
1800	RV1800-2SAC-S/S	78351	117.7
1950	RV1950-2SAC-S/S	78663	122.7
2100	RV2100-2SAC-S/S	78352	127.8
2400	RV2400-2SAC-S/S	78353	138.0
3000	RV3000-2SAC-S/S	78354	160.6

*NOTE: V-Tips can be used ONLY on vulcanised belts.

Product Notes:

- Patent-pending Service Advantage Cartridge™ allows for easy removal in even the dirtiest conditions.
- Pole Length: Belt width plus 1350mm (single cartridge cleaners); Belt width plus 1500mm (dual cartridge cleaners).
- Two-way cushions allow cleaning in both directions.
- C-Tips are for mechanically fastened or vulcanised belts. V-Tips are for vulcanised belts only.
- Tensioner mounting brackets included for fast and easy installation.
- Cartridge Removal Kit included for easy removal of the cartridge.

U.S. Patent No. 7,987,966; 8,757,360; 8,312,986;
8,640,856; 9,090,405; 9,085,419

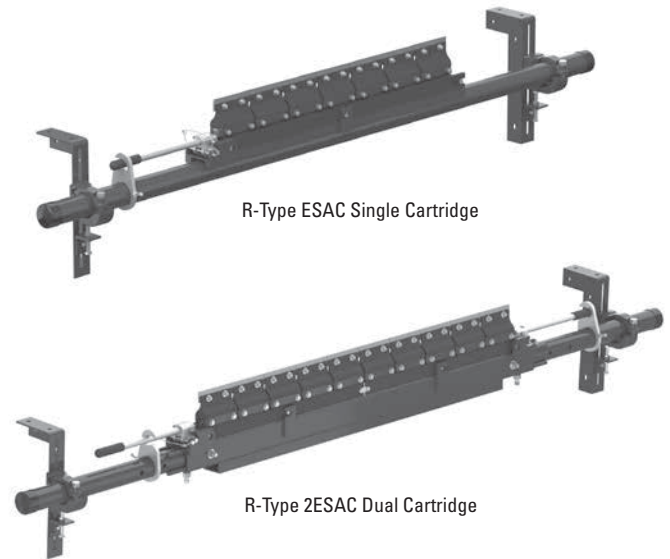

R-Type ESAC Single Cartridge

R-Type 2ESAC Dual Cartridge

Replacement Tips

ORDERING NUMBER	ITEM CODE	WT. KG.
CT6 (C-Tip)	74535	0.4
RSA150 (V-Tip)	73628	0.4

Tips Required Per Cleaner Size

BELT WIDTH mm	BLADE COVERAGE mm	V-TIPS REQUIRED
600	600	4
750	750	5
900	900	6
1050	1050	7
1200	1200	8
1350	1350	9
1500	1500	10
1800	1800	12
2100	2100	14
2400	2400	16
3000	3000	20

Stock items (non-shaded) refer to (*) for specific lead time, if not specified, standard lead time applies.

Non-stock items (shaded) please contact Flexco for dispatch options and lead times.

Product Ordering Information

R-Type® SAC
Secondary Cleaner
with Service Advantage Cartridge™

R-Type® SAC Cartridge Kits with V-Tips*

BELT WIDTH mm	ORDERING NUMBER	ITEM CODE	WT. KG.
600	R-CARK-V24/600	78106	12.3
750	R-CARK-V30/750	78107	14.7
900	R-CARK-V36/900	78108	16.5
1050	R-CARK-V42/1050	78109	19.3
1200	R-CARK-V48/1200	78110	21.6
1350	R-CARK-V54/1350	78111	24.0
1500	R-CARK-V60/1500	78112	26.4
1800	R-CARK-V72/1800	78113	31.1
1500	R-CARK2-V60/1500	78119	31.6
1800	R-CARK2-V72/1800	78120	33.9
2100	R-CARK2-V84/2100	78121	38.6
2400	R-CARK2-V96/2400	78122	43.3
3000	R-CARK2-V120/3000	78123	52.8

*NOTE: V-Tips can be used ONLY on vulcanised belts.

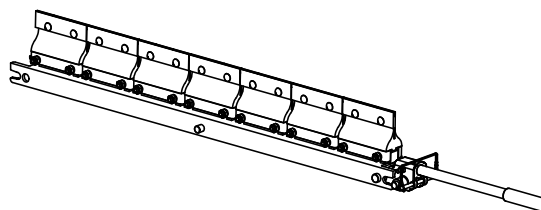

R-Type SAC Single Cartridge Kit

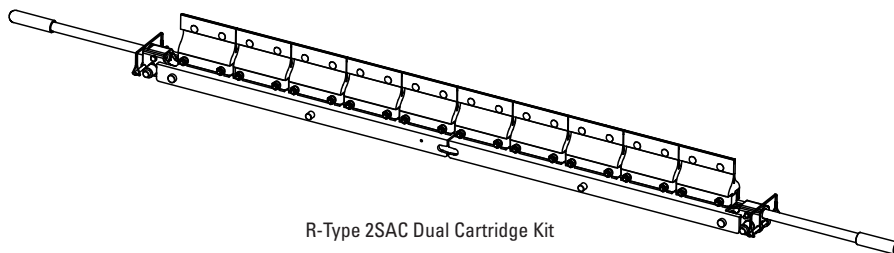

R-Type 2SAC Dual Cartridge Kit

R-Type SAC Stainless Steel Cartridge Kits with V-Tips*

BELT WIDTH mm	ORDERING NUMBER	ITEM CODE	WT. KG.
600	R-CARK-V24/600-S/S RVECKSS	82828	12.3
750	R-CARK-V30/750-S/S RVECKSS	82829	14.7
900	R-CARK-V36/900-S/S RVECKSS	82830	16.5
1050	R-CARK-V42/1050-S/S RVECKSS	82831	19.3
1200	R-CARK-V48/1200-S/S RVECKSS	82832	21.6
1350	R-CARK-V54/1350-S/S RVECKSS	82833	24.0
1500	R-CARK-V60/1500-S/S RVECKSS	82834	26.4
1800	R-CARK-V72/1800-S/S RVECKSS	82835	31.1
1500	R-CARK2-V60/1500-S/S RV2ECKSS	82836	31.6
1800	R-CARK2-V72/1800-S/S RV2ECKSS	82837	33.9
2100	R-CARK2-V84/2100-S/S RV2ECKSS	82838	38.6
2400	R-CARK2-V96/2400-S/S RV2ECKSS	82839	43.3
3000	R-CARK2-V120/3000-S/S RV2ECKSS	82840	52.8

*NOTE: V-Tips can be used ONLY on vulcanised belts.

Stock items (non-shaded) refer to (*) for specific lead time, if not specified, standard lead time applies.

Non-stock items (shaded) please contact Flexco for dispatch options and lead times.

U.S. Patent No. 7,987,966; 8,757,360; 8,312,986;
 8,640,856; 9,090,405; 9,085,419

Replacement Parts List

R-Type® SAC (Mild Steel) Secondary Cleaner with Service Advantage Cartridge™

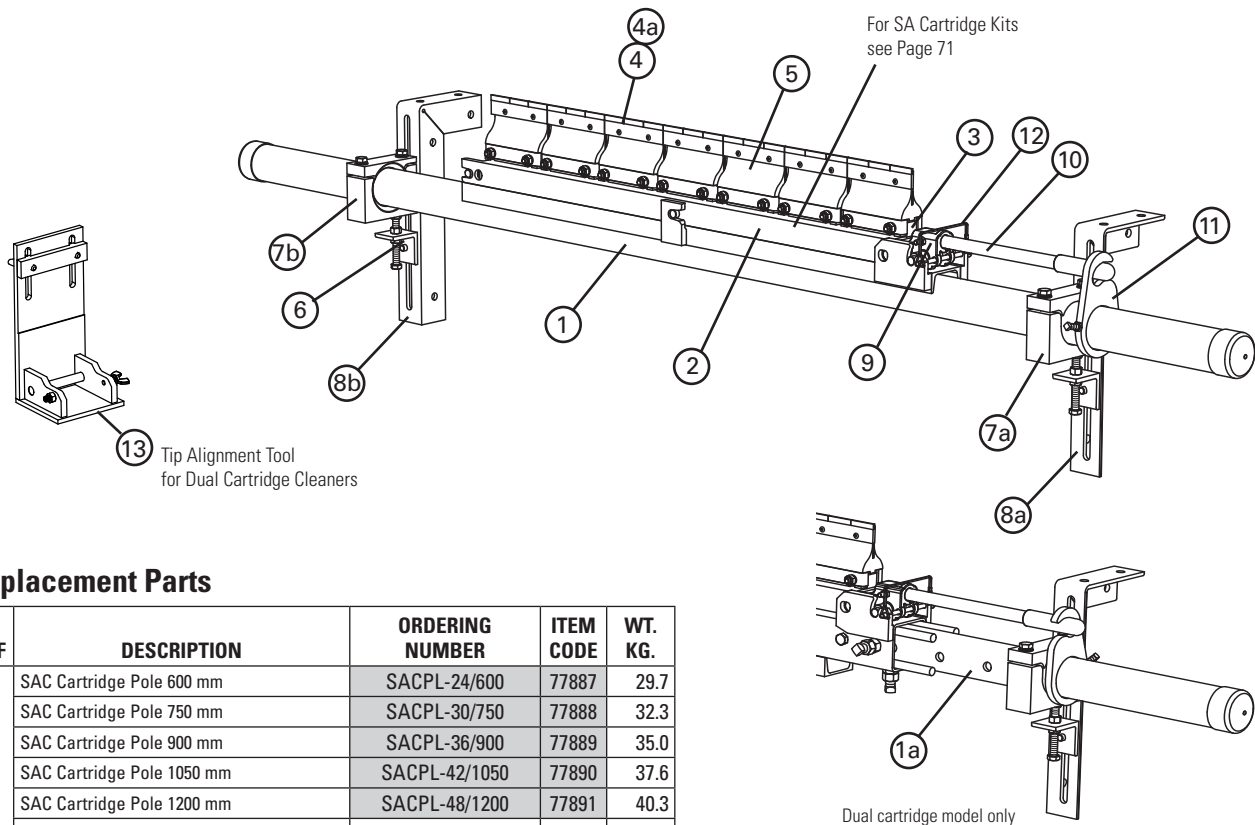

Replacement Parts

REF	DESCRIPTION	ORDERING NUMBER	ITEM CODE	WT. KG.
1	SAC Cartridge Pole 600 mm	SACPL-24/600	77887	29.7
	SAC Cartridge Pole 750 mm	SACPL-30/750	77888	32.3
	SAC Cartridge Pole 900 mm	SACPL-36/900	77889	35.0
	SAC Cartridge Pole 1050 mm	SACPL-42/1050	77890	37.6
	SAC Cartridge Pole 1200 mm	SACPL-48/1200	77891	40.3
	SAC Cartridge Pole 1350 mm	SACPL-54/1350	77892	42.9
	SAC Cartridge Pole 1500 mm	SACPL-60/1500	77893	45.6
	SAC Cartridge Pole 1800 mm	SACPL-72/1800	77894	50.9
	SAC Cartridge Center Pole 1500 mm (Dual)	SACPL2-60/1500	77895	35.1
	SAC Cartridge Center Pole 1800 mm (Dual)	SACPL2-72/1800	77896	40.6
	SAC Cartridge Center Pole 2100 mm (Dual)	SACPL2-84/2100	77897	46.2
	SAC Cartridge Center Pole 2400 mm (Dual)	SACPL2-96/2400	77898	51.8
	SAC Cartridge Center Pole 3000 mm (Dual)	SACPL2-120/3000	77899	64.5
1a	Extender Pole (for use with Dual Cartridge Center Pole)	MHP-EP	76392	24.5
2	SAC Repl Cartridge S/S 600 mm	CART-24/600-S/S	78576	4.5
	SAC Repl Cartridge S/S 750 mm	CART-30/750-S/S	78577	5.6
	SAC Repl Cartridge S/S 900 mm	CART-36/900-S/S	78578	6.7
	SAC Repl Cartridge S/S 1050 mm	CART-42/1050-S/S	78579	7.8
	SAC Repl Cartridge S/S 1200 mm	CART-48/1200-S/S	78580	8.9
	SAC Repl Cartridge S/S 1350 mm	CART-54/1350-S/S	78581	10.0
	SAC Repl Cartridge S/S 1500 mm	CART-60/1500-S/S	78582	11.3
	SAC Repl Cartridge S/S 1800 mm	CART-72/1800-S/S	78583	13.5
	SAC Repl Cartridge S/S 1500 mm (Dual)	CART2-60/1500-S/S	78584	11.2
	SAC Repl Cartridge S/S 1800 mm (Dual)	CART2-72/1800-S/S	78585	13.4
	SAC Repl Cartridge S/S 1950 mm (Dual)	CART2-78/1950-S/S	78635	14.5
	SAC Repl Cartridge S/S 2100 mm (Dual)	CART2-84/2100-S/S	78586	15.6
	SAC Repl Cartridge S/S 2400 mm (Dual)	CART2-96/2400-S/S	78587	17.8
	SAC Repl Cartridge S/S 3000 mm (Dual)	CART2-120/3000-S/S	78588	22.6

U.S. Patent No. 7,987,966; 8,757,360; 8,312,986;
8,640,856; 9,090,405; 9,085,419

Stock items (non-shaded) refer to (*) for specific lead time, if not specified, standard lead time applies.

Non-stock items (shaded) please contact Flexco for dispatch options and lead times.

Replacement Parts List

R-Type® SAC (Mild Steel) Secondary Cleaner with Service Advantage Cartridge™

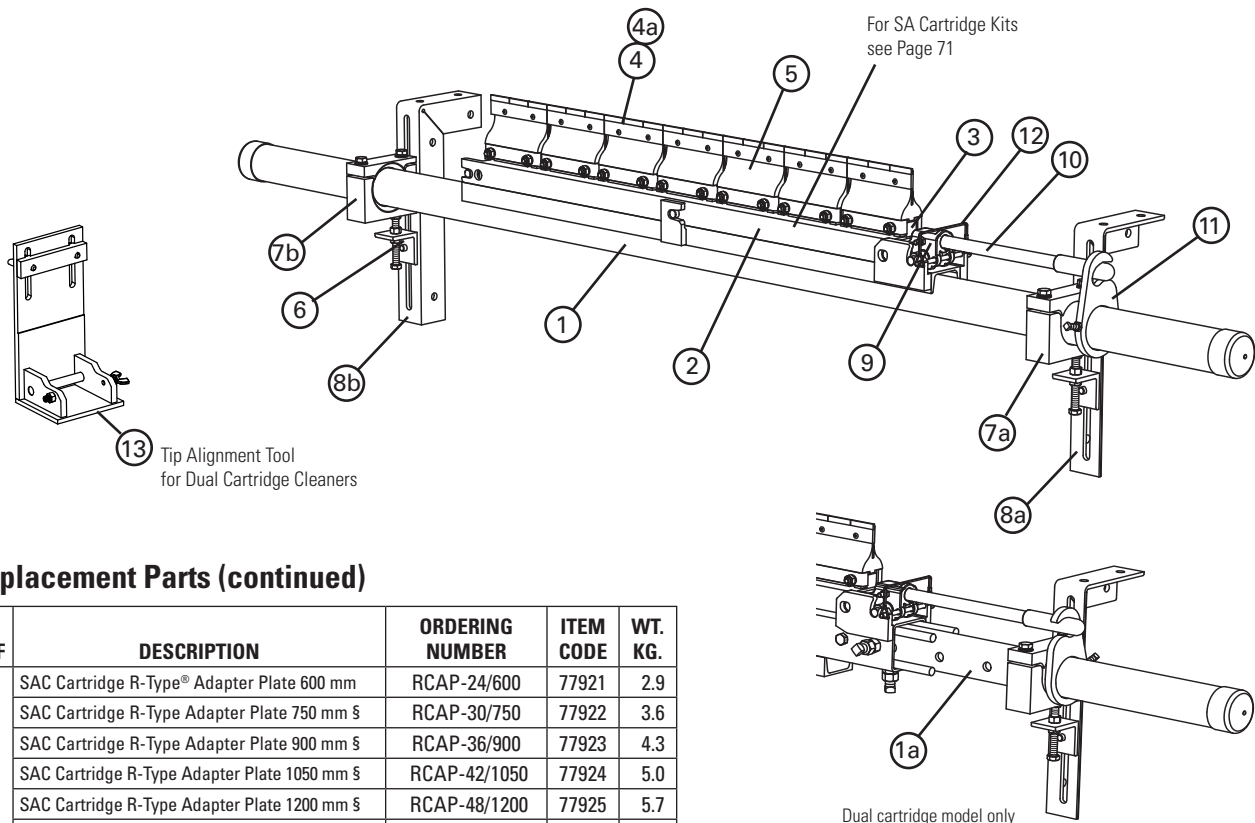

Replacement Parts (continued)

REF	DESCRIPTION	ORDERING NUMBER	ITEM CODE	WT. KG.
3	SAC Cartridge R-Type® Adapter Plate 600 mm	RCAP-24/600	77921	2.9
	SAC Cartridge R-Type Adapter Plate 750 mm §	RCAP-30/750	77922	3.6
	SAC Cartridge R-Type Adapter Plate 900 mm §	RCAP-36/900	77923	4.3
	SAC Cartridge R-Type Adapter Plate 1050 mm §	RCAP-42/1050	77924	5.0
	SAC Cartridge R-Type Adapter Plate 1200 mm §	RCAP-48/1200	77925	5.7
	SAC Cartridge R-Type Adapter Plate 1350 mm	RCAP-54/1350	77926	6.4
	SAC Cartridge R-Type Adapter Plate 1500 mm §	RCAP-60/1500	77927	7.2
	SAC Cartridge R-Type Adapter Plate 1800 mm	RCAP-72/1800	77928	8.6
4	C-Tip*	CT6	74535	0.4
4a	R V-Tip* (for vulcanised belts only)	RSA150	73628	0.4
	Cushion*	RSA	76249	0.4
	P/R Adjusting Bracket	PAB	75513	0.4
	7a Cradle Clamp Block RH	SMR-CCB-R73	A2843	1.2
	7b Cradle Clamp Block LH	SMR-CCB-L73	A2842	1.2
	8a Mounting Bracket Kit, RH	PMBR	75519	3.8
	8b Mounting Bracket Kit, LH	PMBL	75516	3.8
	9 SAC Removal Knuckle	SACRKN	77882	1.5
	10 SAC Removal Handle	SACRH	77883	1.4
	11 SAC Handle Lock Plate	SACRHL	77884	0.8
	12 Knuckle Retainer Pin	SACKRP	77885	0.1
-	SAC Removal Kit (includes 1 ea. items 9,10,11,12)	SACRKT	77886	4.1
13	SAC Cartridge Tip Alignment Tool (Dual)	SAC2-TIP-TL	77866	1.1
-	Cradle Clamp Heavy-Duty Mounting Kit (inc. 2 ea. items 6, 8; 1 ea. items 7a, 7b)	CRHMK	62400	10.8

§ If using a dual cartridge, please take the cleaner size and divide by two. That dimension is the size of the brackets needed for conversion to an R-Type cleaner.

U.S. Patent No. 7,987,966; 8,757,360; 8,312,986;
8,640,856; 9,090,405; 9,085,419

Stock items (non-shaded) refer to (*) for specific lead time, if not specified, standard lead time applies.
Non-stock items (shaded) please contact Flexco for dispatch options and lead times.

Replacement Parts List

R-Type® SAC (Stainless Steel) Secondary Cleaner with Service Advantage Cartridge™

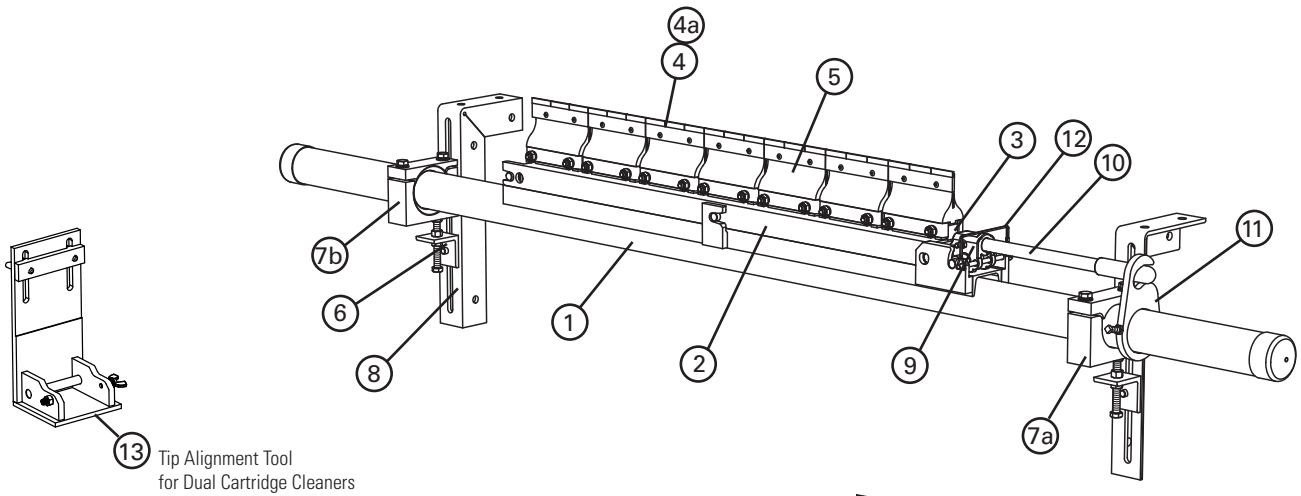

Replacement Parts

REF	DESCRIPTION	ORDERING NUMBER	ITEM CODE	WT. KG.
1	SAC S/S Cartridge Pole 600 mm	SACPL-24/600-S/S	78371	29.7
	SAC S/S Cartridge Pole 750 mm	SACPL-30/750-S/S	78372	32.3
	SAC S/S Cartridge Pole 900 mm	SACPL-36/900-S/S	78373	35.0
	SAC S/S Cartridge Pole 1050 mm	SACPL-42/1050-S/S	78374	37.6
	SAC S/S Cartridge Pole 1200 mm	SACPL-48/1200-S/S	78375	40.3
	SAC S/S Cartridge Pole 1350 mm	SACPL-54/1350-S/S	78376	42.9
	SAC S/S Cartridge Pole 1500 mm	SACPL-60/1500-S/S	78377	45.6
	SAC S/S Cartridge Pole 1800 mm	SACPL-72/1800-S/S	78378	50.9
	SAC S/S Cartridge Center Pole 1500 mm (Dual)	SACPL2-60/1500-S/S	78379	35.1
	SAC S/S Cartridge Center Pole 1800 mm (Dual)	SACPL2-72/1800-S/S	78380	40.6
	SAC S/S Cartridge Center Pole 1950 mm (Dual)	SACPL2-78/1950-S/S	78642	43.9
	SAC S/S Cartridge Center Pole 2100 mm (Dual)	SACPL2-84/2100-S/S	78381	46.2
	SAC S/S Cartridge Center Pole 2400 mm (Dual)	SACPL2-96/2400-S/S	78382	51.8
	SAC S/S Cartridge Center Pole 3000 mm (Dual)	SACPL2-120/3000-S/S	78383	64.5
1a	S/S Extender Pole (for use with S/S Dual Cartridge Center Pole)	MHP-EP-S/S	77599	24.5
2	SAC Repl Cartridge S/S 600 mm	CART-24/600-S/S	78576	4.5
	SAC Repl Cartridge S/S 750 mm	CART-30/750-S/S	78577	5.6
	SAC Repl Cartridge S/S 900 mm	CART-36/900-S/S	78578	6.7
	SAC Repl Cartridge S/S 1050 mm	CART-42/1050-S/S	78579	7.8
	SAC Repl Cartridge S/S 1200 mm	CART-48/1200-S/S	78580	8.9
	SAC Repl Cartridge S/S 1350 mm	CART-54/1350-S/S	78581	10.0
	SAC Repl Cartridge S/S 1500 mm	CART-60/1500-S/S	78582	11.3
	SAC Repl Cartridge S/S 1800 mm	CART-72/1800-S/S	78583	13.5
	SAC Repl Cartridge S/S 1500 mm (Dual)	CART2-60/1500-S/S	78584	11.2
	SAC Repl Cartridge S/S 1800 mm (Dual)	CART2-72/1800-S/S	78585	13.4
	SAC Repl Cartridge S/S 1950 mm (Dual)	CART2-78/1950-S/S	78635	14.5
	SAC Repl Cartridge S/S 2100 mm (Dual)	CART2-84/2100-S/S	78586	15.6
	SAC Repl Cartridge S/S 2400 mm (Dual)	CART2-96/2400-S/S	78587	17.8
	SAC Repl Cartridge S/S 3000 mm (Dual)	CART2-120/3000-S/S	78588	22.6

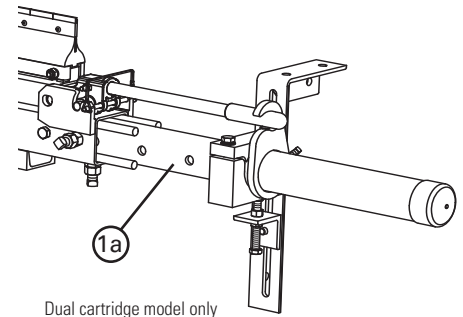

U.S. Patent No. 7,987,966; 8,757,360; 8,312,986; 8,640,856; 9,090,405; 9,085,419

Stock items (non-shaded) refer to (*) for specific lead time, if not specified, standard lead time applies.
 Non-stock items (shaded) please contact Flexco for dispatch options and lead times.

Replacement Parts List

R-Type® SAC (Stainless Steel) Secondary Cleaner with Service Advantage Cartridge™

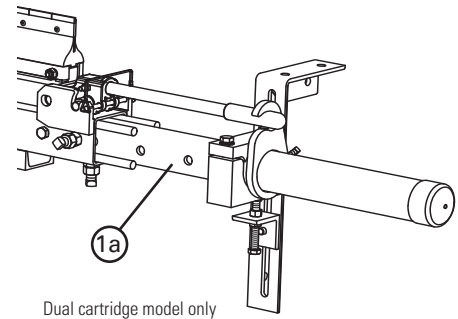
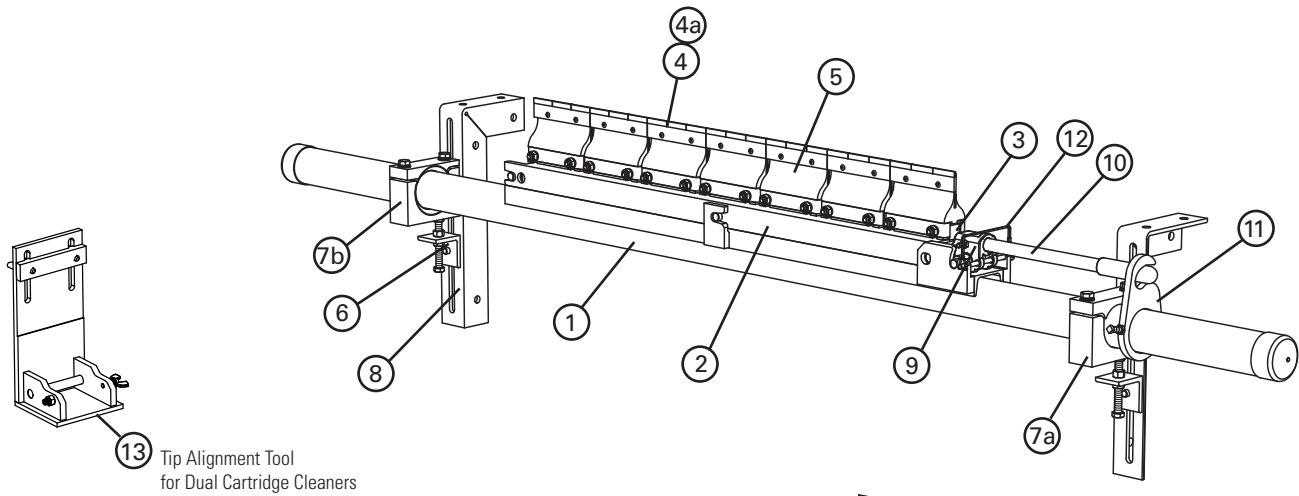

Replacement Parts (continued)

REF	DESCRIPTION	ORDERING NUMBER	ITEM CODE	WT. KG.
3	SAC Cartridge R-Type® S/S Adapter Plate 600 mm	RCAP-24/600-S/S	78363	2.9
	SAC Cartridge R-Type S/S Adapter Plate 750 mm §	RCAP-30/750-S/S	78364	3.6
	SAC Cartridge R-Type S/S Adapter Plate 900 mm §	RCAP-36/900-S/S	78365	4.3
	SAC Cartridge R-Type S/S Adapter Plate 1050 mm §	RCAP-42/1050-S/S	78366	5.0
	SAC Cartridge R-Type S/S Adapter Plate 1200 mm §	RCAP-48/1200-S/S	78367	5.7
	SAC Cartridge R-Type S/S Adapter Plate 1350 mm	RCAP-54/1350-S/S	78368	6.4
	SAC Cartridge R-Type S/S Adapter Plate 1500 mm §	RCAP-60/1500-S/S	78369	7.2
	SAC Cartridge R-Type S/S Adapter Plate 1800 mm	RCAP-72/1800-S/S	78370	8.6
4	C-Tip	CT6	74535	0.4
4a	S/S V-Tip* (for vulcanised belts only)	RVT6-S/S	76205	0.4
5	S/S R Cushion*	RC-S/S	76250	1.4
6	P/R Adjusting Bracket S/S	PAB-S/S	75515	0.4
7a	Cradle Clamp LH S/S CRDLBLK-LH	CRDLBLK-RH-S/S	A2825	1.2
7b	Cradle Clamp RH S/S CRDLBLK-RH	CRDLBLK-LH-S/S	A2826	1.2
8a	Mounting Bracket Kit RH S/S	PMBR-S/S	75521	3.8
8b	Mounting Bracket Kit LH S/S	PMBL-S/S	75518	3.8
9	SAC Removal Knuckle	SACRKN	77882	1.5
10	SAC Removal Handle S/S	SACRH-S/S	78397	1.4
11	SAC Handle Lock Plate S/S	SACRHL-S/S	78398	0.8
12	Knuckle Retainer Pin S/S	SACKRP-S/S	78399	0.1
-	SAC Removal Kit S/S (includes 1 ea. items 9,10,11,12)	SACRKT-S/S	78401	4.1
13	SAC Cartridge Tip Alignment Tool (Dual)	SAC2-TIP-TL	77866	1.1
-	Cradle Clamp Stainless Steel Heavy-Duty Mounting Kit (incl. 2 ea. item 6; incl. 1 ea. items 7a, 7b, 8a, 8b)	CRHMK-S/S	62095	10.8

§ If using a dual cartridge, please take the cleaner size and divide by two. That dimension is the size of the brackets needed for conversion to an R-Type cleaner.

U.S. Patent No. 7,987,966; 8,757,360; 8,312,986; 8,640,856; 9,090,405; 9,085,419

Stock items (non-shaded) refer to (*) for specific lead time, if not specified, standard lead time applies.
Non-stock items (shaded) please contact Flexco for dispatch options and lead times.

Specifications & Guidelines

R-Type® SAC
Secondary Cleaner
with Service Advantage Cartridge™

Pole Length Specifications*

VERSION	CLEANER SIZE mm	BLADE WIDTH mm	POLE LENGTH mm	MAXIMUM CONVEYOR SPAN mm
Single	600	600	1950	1650
	750	750	2100	1800
	900	900	2250	1950
	1050	1050	2400	2100
	1200	1200	2550	2250
	1350	1350	2700	2400
	1500	1500	2850	2550
Dual	1500	1500	3000	2700
	1800	1800	3300	3000
	2100	2100	3600	3300
	2400	2400	3900	3600
	3000	3000	4500	4200

*For special extra long pole length requirements a Pole Extender Kit (#76024) is available that provides 750 mm of extended pole length. Pole Diameter - 73 mm

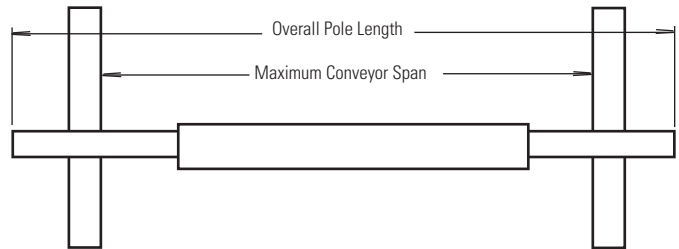

Clearance Guidelines for Installation

VERSION	HORIZONTAL CLEARANCE REQUIRED mm	VERTICAL CLEARANCE REQUIRED mm
Single	114	254
Dual	114	298

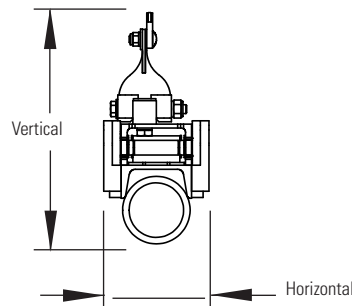

Specifications:

- Maximum Belt Speed5M/sec
- Temperature Rating-35°C to 82°C
- Usable Blade Wear Length.....9 mm
- Blade MaterialsC-Tip: Impact Resistant Tungsten Carbide (works with mechanical fasteners)
V-Tip: Long Life Tungsten Carbide (for vulcanised belts only)
- Available for Belt Widths600 to 3000 mm. Other sizes available upon request.

U.S. Patent No. 7,987,966; 8,757,360; 8,312,986;
8,640,856; 9,090,405; 9,085,419

Product Ordering Information

MHS SAC HD Secondary Cleaner with Service Advantage Cartridge™

MHS SAC Secondary with V-Tips*

BELT WIDTH mm	ORDERING NUMBER	ITEM CODE	WT. KG.
600	MHS-600V-SAC	78162	88.5
750	MHS-750V-SAC	78163	93.7
900	MHS-900V-SAC	78164	99.1
1050	MHS-1050V-SAC	78165	104.4
1200	MHS-1200V-SAC	78166	109.6
1350	MHS-1350V-SAC	78167	114.8
1500	MHS-1500V-SAC	78168	120.2
1800	MHS-1800V-SAC	78169	130.8
1500	MHS-1500V-2SAC	78170	140.2
1800	MHS-1800V-2SAC	78171	151.0
2100	MHS-2100V-2SAC	78172	161.8
2400	MHS-2400V-2SAC	78173	172.9
3000	MHS-3000V-2SAC	78174	196.2

*NOTE: V-Tips can be used ONLY on vulcanised belts.

MHS SAC Stainless Steel Secondary with V-Tips*

BELT WIDTH mm	ORDERING NUMBER	ITEM CODE	WT. KG.
600	MHS-600V-SAC-S/S	78537	88.5
750	MHS-750V-SAC-S/S	78538	93.7
900	MHS-900V-SAC-S/S	78539	99.1
1050	MHS-1050V-SAC-S/S	78540	104.4
1200	MHS-1200V-SAC-S/S	78541	109.6
1350	MHS-1350V-SAC-S/S	78542	114.8
1500	MHS-1500V-SAC-S/S	78543	120.2
1800	MHS-1800V-SAC-S/S	78544	130.8
1500	MHS-1500V-2SAC-S/S	78545	140.2
1800	MHS-1800V-2SAC-S/S	78546	151.0
1950	MHS-1950V-2SAC-S/S	78649	156.0
2100	MHS-2100V-2SAC-S/S	78547	161.8
2400	MHS-2400V-2SAC-S/S	78548	172.9
3000	MHS-3000V-2SAC-S/S	78549	196.2

*NOTE: V-Tips can be used ONLY on vulcanised belts.

Product Notes:

- Patent-pending Service Advantage Cartridge™ allows for easy removal in even the dirtiest conditions.
- Heavy-duty design to deliver maximum cleaning efficiency on the most demanding, abusive beltlines.
- Pole Length: Belt width plus 1350 mm (single cartridge cleaners); Belt width plus 1500 mm (dual cartridge cleaners).
- Patented PowerFlex™ cushion design to maintain continuous blade-to-belt contact and quick relief from passing mechanical splices.
- C-Tips are for mechanically fastened or vulcanised belts. V-Tips are for vulcanised belts only.
- Visual Blade Tension Check: Measure the tension spring and refer to Spring Length Chart on mounting base for the correct length for best cleaning performance.
- Tensioner mounting brackets included for fast and easy installation.
- Cartridge Removal Kit included for easy removal of the cartridge.

U.S. Patent No. 7,987,966; 8,757,360; 8,312,986;
8,640,856; 9,090,405; 9,085,419

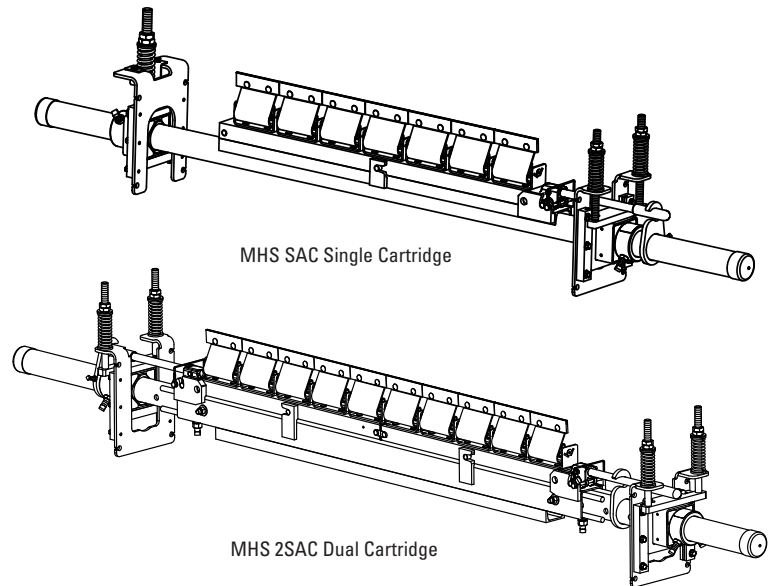

Replacement Tips

ORDERING NUMBER	ITEM CODE	WT. KG.
CT6 (C-Tip)	74535	0.4
RSA150 (V-Tip)	73628	0.4

Tips Required Per Cleaner Size

BELT WIDTH mm	BLADE COVERAGE mm	V-TIPS REQUIRED
600	600	4
750	750	5
900	900	6
1050	1050	7
1200	1200	8
1350	1350	9
1500	1500	10
1800	1800	12
2100	2100	14
2400	2400	16
3000	3000	20

Stock items (non-shaded) refer to (*) for specific lead time, if not specified, standard lead time applies.

Non-stock items (shaded) please contact Flexco for dispatch options and lead times.

Product Ordering Information

MHS SAC HD Secondary Cleaner with Service Advantage Cartridge™

MHS SAC Cartridge Kits with V-Tips*

BELT WIDTH mm	ORDERING NUMBER	ITEM CODE	WT. KG.
600	MHS-CARK-V24/600	77937	13.3
750	MHS-CARK-V30/750	77938	15.9
900	MHS-CARK-V36/900	77939	18.5
1050	MHS-CARK-V42/1050	77940	21.1
1200	MHS-CARK-V48/1200	77941	23.7
1350	MHS-CARK-V54/1350	77942	26.3
1500	MHS-CARK-V60/1500	77943	28.9
1800	MHS-CARK-V72/1800	77944	34.2
1500	MHS-CARK2-V60/1500	77950	31.8
1800	MHS-CARK2-V72/1800	77951	37.0
2100	MHS-CARK2-V84/2100	77952	42.2
2400	MHS-CARK2-V96/2400	77953	47.4
3000	MHS-CARK2-V120/3000	77954	57.9

*NOTE: V-Tips can be used ONLY on vulcanised belts.

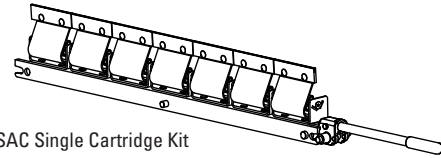

MHS SAC Single Cartridge Kit

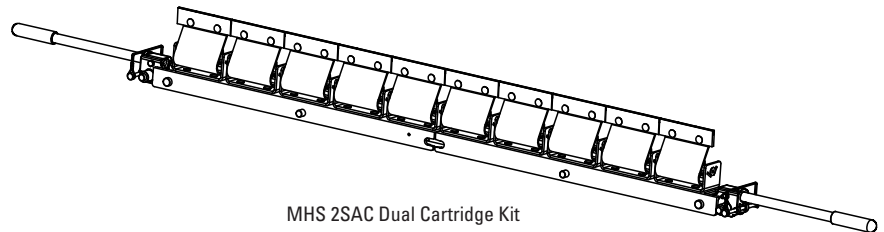

MHS 2SAC Dual Cartridge Kit

MHS SAC Stainless Steel Cartridge Kits with V-Tips*

BELT WIDTH mm	ORDERING NUMBER	ITEM CODE	WT. KG.
600	MHS-CARK-V24/600-S/S MVECKS/S	82841	13.3
750	MHS-CARK-V30/750-S/S MVECKS/S	82842	15.9
900	MHS-CARK-V36/900-S/S MVECKS/S	82843	18.5
1050	MHS-CARK-V42/1050-S/S MVECKS/S	82844	21.1
1200	MHS-CARK-V48/1200-S/S MVECKS/S	82845	23.7
1350	MHS-CARK-V54/1350-S/S MVECKS/S	82846	26.3
1500	MHS-CARK-V60/1500-S/S MVECKS/S	82847	28.9
1800	MHS-CARK-V72/1800-S/S MVECKS/S	82848	34.2
1500	MHS-CARK2-V60/1500-S/S MV2CKSS	82849	31.8
1800	MHS-CARK2-V72/1800-S/S MV2CKSS	82850	37.0
2100	MHS-CARK2-V84/2100-S/S MV2CKSS	82851	42.2
2400	MHS-CARK2-V96/2400-S/S MV2CKSS	82852	47.4
3000	MHS-CARK2-V120/3000-S/S MV2CKS	82853	57.9

*NOTE: V-Tips can be used ONLY on vulcanised belts.

U.S. Patent No. 7,987,966; 8,757,360; 8,312,986;
8,640,856; 9,090,405; 9,085,419

Stock items (non-shaded) refer to (*) for specific lead time, if not specified, standard lead time applies.

Non-stock items (shaded) please contact Flexco for dispatch options and lead times.

Replacement Parts List

MHS SAC (Mild Steel) HD Secondary Cleaner with Service Advantage Cartridge™

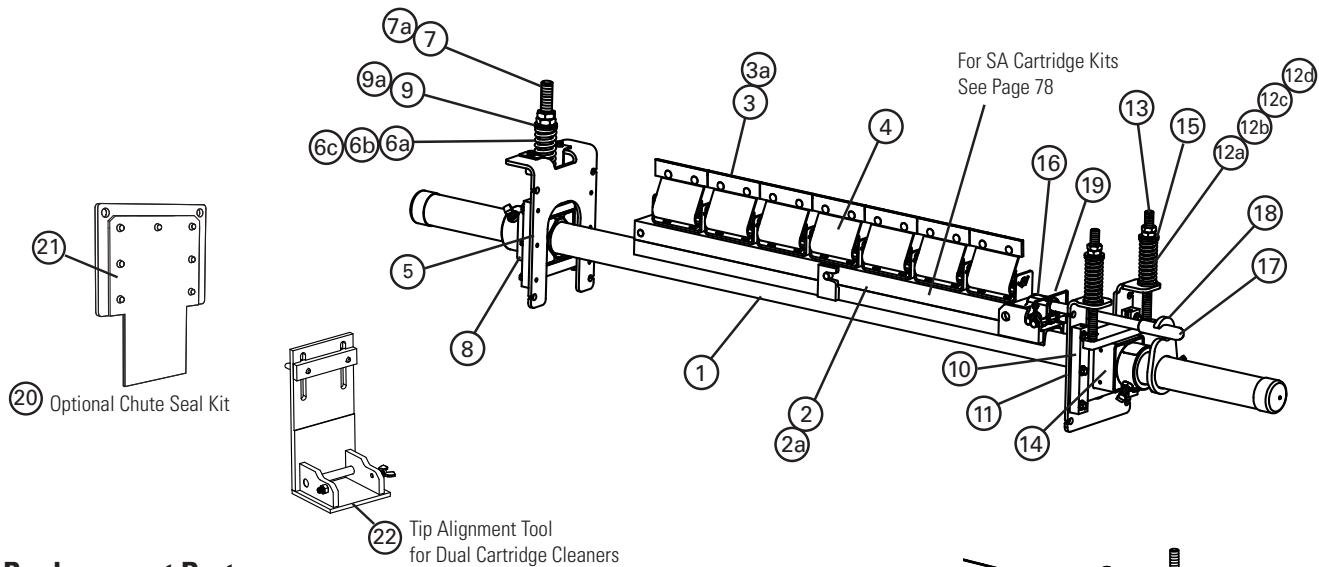

Replacement Parts

REF	DESCRIPTION	ORDERING NUMBER	ITEM CODE	WT. KG.
1	SAC Cartridge Pole 600mm	SACPL-24/600	77887	29.7
	SAC Cartridge Pole 750mm	SACPL-30/750	77888	32.3
	SAC Cartridge Pole 900mm	SACPL-36/900	77889	35.0
	SAC Cartridge Pole 1050mm	SACPL-42/1050	77890	37.6
	SAC Cartridge Pole 1200mm	SACPL-48/1200	77891	40.3
	SAC Cartridge Pole 1350mm	SACPL-54/1350	77892	42.9
	SAC Cartridge Pole 1500mm	SACPL-60/1500	77893	45.6
	SAC Cartridge Pole 1800mm	SACPL-72/1800	77894	50.9
	SAC Cartridge Center Pole 1500mm (Dual)	SACPL2-60/1500	77895	35.1
	SAC Cartridge Center Pole 1800mm (Dual)	SACPL2-72/1800	77896	40.6
	SAC Cartridge Center Pole 2100mm (Dual)	SACPL2-84/2100	77897	46.2
	SAC Cartridge Center Pole 2400mm (Dual)	SACPL2-96/2400	77898	51.8
	SAC Cartridge Center Pole 3000mm (Dual)	SACPL2-120/3000	77899	64.5
1a	Extender Pole (for use with Dual Cartridge Center Pole)	MHP-EP	76392	24.5
2	SAC Repl Cartridge S/S 600 mm	CART-24/600-S/S	78576	4.5
	SAC Repl Cartridge S/S 750 mm	CART-30/750-S/S	78577	5.6
	SAC Repl Cartridge S/S 900 mm	CART-36/900-S/S	78578	6.7
	SAC Repl Cartridge S/S 1050 mm	CART-42/1050-S/S	78579	7.8
	SAC Repl Cartridge S/S 1200 mm	CART-48/1200-S/S	78580	8.9
	SAC Repl Cartridge S/S 1350 mm	CART-54/1350-S/S	78581	10.0
	SAC Repl Cartridge S/S 1500 mm	CART-60/1500-S/S	78582	11.3
	SAC Repl Cartridge S/S 1800 mm	CART-72/1800-S/S	78583	13.5
	SAC Repl Cartridge S/S 1500 mm (Dual)	CART2-60/1500-S/S	78584	11.2
	SAC Repl Cartridge S/S 1800 mm (Dual)	CART2-72/1800-S/S	78585	13.4
	SAC Repl Cartridge S/S 1950 mm (Dual)	CART2-78/1950-S/S	78635	14.5
	SAC Repl Cartridge S/S 2100 mm (Dual)	CART2-84/2100-S/S	78586	15.6
	SAC Repl Cartridge S/S 2400 mm (Dual)	CART2-96/2400-S/S	78587	17.8
SAC Repl Cartridge S/S 3000 mm (Dual)	CART2-120/3000-S/S	78588	22.6	
3	C-Tip*	CT6	74535	0.4
3a	V-Tip* (for vulcanised belts only)	RSA150	73628	0.4
4	PowerFlex™ Cushion*	SPFC	79200	0.9
5	SST HD Mounting Base Kit* (includes 1 mounting base and 2 slide guides)	SSTHDMK	77870	4.6

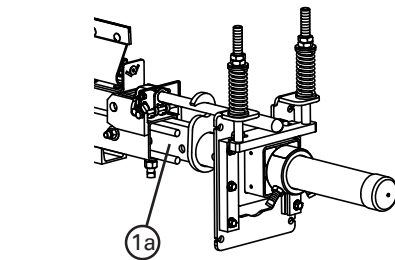

Dual cartridge model only

Stock items (non-shaded) refer to (*) for specific lead time, if not specified, standard lead time applies.
Non-stock items (shaded) please contact Flexco for dispatch options and lead times.

U.S. Patent No. 7,987,966; 8,757,360; 8,312,986; 8,640,856; 9,090,405; 9,085,419

Replacement Parts List

MHS SAC (Mild Steel) HD® Secondary Cleaner with Service Advantage Cartridge™

Replacement Parts (continued)

REF	DESCRIPTION	ORDERING NUMBER	ITEM CODE	WT. KG.
6a	SST Spring - White (1 ea.) for belts 450-750mm	STS-W	75846	0.2
6b	SST Spring - Silver (1 ea.) for belts 900-1500mm	STS-S	75843	0.4
6c	SST Spring - Black (1 ea.) for belts 1800-2100mm	STS-B	75844	0.5
6d	SST Spring - Gold (1 ea.) for belts over 2100mm	STS-G	78142	0.7
7	SST Adj Rod Kit*(incl. 1 rod, 2 nuts, 2 bushings, 1 washer) for belts 450-1500 mm	STAK	75847	1.3
7a	SST HD® Adj Rod Kit*(incl. 1 rod, 2 nuts, 2 HD bushings, 1 washer) for belts 1800-2100mm	STAKHD	75892	1.4
8	SST HD Torsion Pole Mount* (1 ea.)	SSTHDPM	77868	6.8
9	SST Bushing Kit - White/Silver	SSTBK-W	76636	0.1
9a	SST Bushing Kit - Black	SSTBK-B	76637	0.1
10	ST Slide Guide Kit	STGK2	77635	0.5
-	SST HD Cartridge Tensioner - White (includes 1 ea. item 5, 6a, 7, 8) for belts 450-750 mm	SST1HDM-W	78517	13.7
-	SST HD Cartridge Tensioner - Silver (includes 1 ea. item 5, 6b, 7, 8) for belts 900-1500 mm	SST1HDM-S	78518	13.9
-	SST HD Cartridge Tensioner - Black (includes 1 ea. item 5, 6c, 7a, 8) for belts 1800-2100 mm	SST1HDM-B	78519	14.1
-	SST HD Cartridge Tensioner - Gold (includes 1 ea. item 5, 6d, 7a, 8) for belts over 2100 mm	SST1HDM-G	79069	14.3
11	CST HD Mounting Base Kit*	CSTHDMK	77871	3.9
12a	CST Spring - White (1 ea.) for belts 450-750 mm	CTS-W	77742	0.2
12b	CST Spring - Silver (1 ea.) for belts 900-1500 mm	CTS-S	77743	0.2
12c	CST Spring - Black (1 ea.) for belts 1800-2100 mm	CTS-B	77744	0.3
12d	CST Spring - Gold (1 ea.) for belts 2400-3000 mm	CTS-G	77745	0.4

REF	DESCRIPTION	ORDERING NUMBER	ITEM CODE	WT. KG.
13	CST Adj Rod Kit (incl. 2 rods, 4 nuts, 4 bushings, 2 washers)	CSTAK	77031	1.5
14	CST HD Torsion Pole Mount* (1 ea.)	CSTHDPM	77869	7.4
15	CST Bushing Kit (includes 4 bushings)	CSTBK	77037	0.1
-	CST HD Cartridge Tensioner - White (incl. 1 ea. item 11,13,14 and 2 ea. item 12) for belts 450-750 mm	CST1HDM-W	78513	13.7
-	CST HD Cartridge Tensioner - Silver (incl. 1 ea. item 11,13,14 and 2 ea. item 12a) for belts 900-1500 mm	CST1HDM-S	78514	13.7
-	CST HD Cartridge Tensioner - Black (includes 1 ea. item 11,13,14 and 2 ea. item 12b) for belts 1800-2100 mm	CST1HDM-B	78515	13.7
-	CST HD Cartridge Tensioner - Gold (includes 1 ea. item 11,13,14 and 2 ea. item 12c) for belts 2400-3000 mm	CST1HDM-G	78516	13.9
16	SAC Removal Knuckle	SACRKN	77882	1.5
17	SAC Removal Handle	SACRH	77883	1.4
18	SAC Handle Lock Plate	SACRHL	77884	0.8
19	Knuckle Retainer Pin	SACKRP	77885	0.1
-	SAC Removal Kit (includes 1 ea. items 16,17,18,19)	SACRKT	77886	4.1
20	SAC Chute Seal Kit	SACSK	77052	1.8
21	SAC Chute Seal Replacement Cover	SACSRC	77065	0.2
22	SAC Cartridge Tip Alignment Tool (Dual)	SAC2-TIP-TL	77866	1.1

ATV Replacement Parts

REF	DESCRIPTION	ORDERING NUMBER	ITEM CODE	WT. KG.
1	Mounting Bracket LH	PMBL-S/S	75518	3.8
2	Mounting Bracket RH	PMBR-S/S	75521	3.8
3	Air Tensioner Slider	ATV-SLIDE	62425	0.2
4	Air Tension Cradle Blocks 60mm Kit	ATV-MOUNT	62424	2.4
5	Air Tension Cradle Blocks 73mm Kit	ATV-MOUNT	63073	2.4
6	Air Tension Adjusting Angle	ATV-ANGLE	62426	1.0
7	Air Bag	ATV-BAG	62079	0.2
8	Hex Nut S/S	HEX NUT	G1211	0.1
9	Air Line Adaptor	ATV-NIP	62037	0.1
10	PAT Control Box 60psi	PACB60	78683	5.0
11	PAT Control Box 100psi	PACB100	79656	5.0
-	Secondary Air Tension 60mm Complete Kit	ATVK-60	62409	13.0
-	Secondary Air Tension 73mm Complete Kit	ATVK-73	63072	15.0

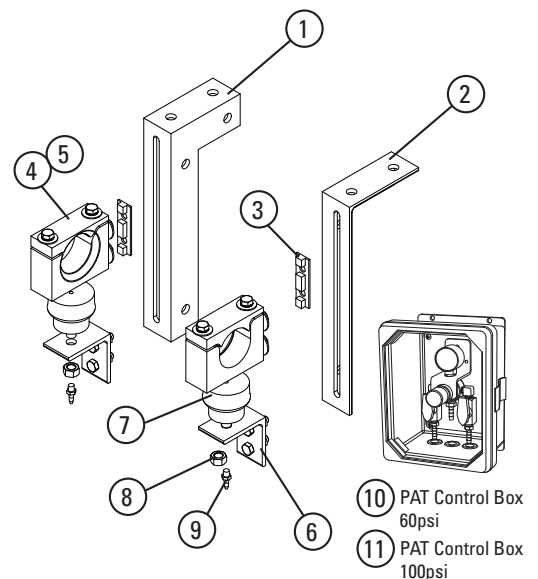

Stock items (non-shaded) refer to (*) for specific lead time, if not specified, standard lead time applies.
Non-stock items (shaded) please contact Flexco for dispatch options and lead times.

U.S. Patent No. 7,987,966; 8,757,360; 8,312,986;
8,640,856; 9,090,405; 9,085,419

Replacement Parts List

MHS SAC (Stainless Steel) HD® Secondary Cleaner with Service Advantage Cartridge™

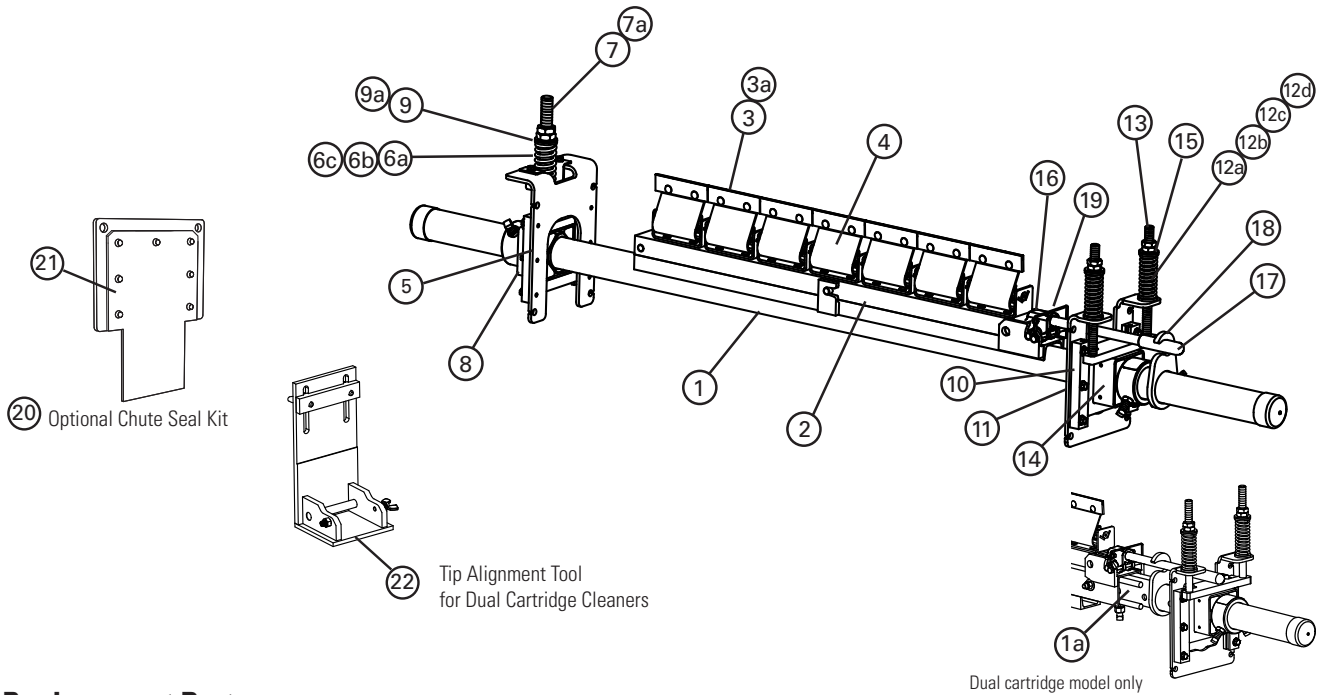

Replacement Parts

REF	DESCRIPTION	ORDERING NUMBER	ITEM CODE	WT. KG.
1	SAC S/S Cartridge Pole 600mm	SACPL-24/600-S/S	78371	29.7
	SAC S/S Cartridge Pole 750mm	SACPL-30/750-S/S	78372	32.3
	SAC S/S Cartridge Pole 900mm	SACPL-36/900-S/S	78373	35.0
	SAC S/S Cartridge Pole 1050mm	SACPL-42/1050-S/S	78374	37.6
	SAC S/S Cartridge Pole 1200mm	SACPL-48/1200-S/S	78375	40.3
	SAC S/S Cartridge Pole 1350mm	SACPL-54/1350-S/S	78376	42.9
	SAC S/S Cartridge Pole 1500mm	SACPL-60/1500-S/S	78377	45.6
	SAC S/S Cartridge Pole 1800mm	SACPL-72/1800-S/S	78378	50.9
	SAC S/S Cartridge Center Pole 1500mm (Dual)	SACPL2-60/1500-S/S	78379	35.1
	SAC S/S Cartridge Center Pole 1800mm (Dual)	SACPL2-72/1800-S/S	78380	40.6
	SAC S/S Cartridge Center Pole 1950mm (Dual)	SACPL2-78/1950-S/S	78642	43.9
	SAC S/S Cartridge Center Pole 2100mm (Dual)	SACPL2-84/2100-S/S	78381	46.2
	SAC S/S Cartridge Center Pole 2400mm (Dual)	SACPL2-96/2400-S/S	78382	51.8
	SAC S/S Cartridge Center Pole 3000mm (Dual)	SACPL2-120/3000-S/S	78383	64.5
1a	S/S Extender Pole (for use with S/S Dual Cartridge Center Pole)	MHP-EP-S/S	77599	24.5

REF	DESCRIPTION	ORDERING NUMBER	ITEM CODE	WT. KG.
2	SAC Repl Cartridge S/S 600 mm	CART-24/600-S/S	78576	4.5
	SAC Repl Cartridge S/S 750 mm	CART-30/750-S/S	78577	5.6
	SAC Repl Cartridge S/S 900 mm	CART-36/900-S/S	78578	6.7
	SAC Repl Cartridge S/S 1050 mm	CART-42/1050-S/S	78579	7.8
	SAC Repl Cartridge S/S 1200 mm	CART-48/1200-S/S	78580	8.9
	SAC Repl Cartridge S/S 1350 mm	CART-54/1350-S/S	78581	10.0
	SAC Repl Cartridge S/S 1500 mm	CART-60/1500-S/S	78582	11.3
	SAC Repl Cartridge S/S 1800 mm	CART-72/1800-S/S	78583	13.5
	SAC Repl Cartridge S/S 1500 mm (Dual)	CART2-60/1500-S/S	78584	11.2
	SAC Repl Cartridge S/S 1800 mm (Dual)	CART2-72/1800-S/S	78585	13.4
	SAC Repl Cartridge S/S 1950 mm (Dual)	CART2-78/1950-S/S	78635	14.5
	SAC Repl Cartridge S/S 2100 mm (Dual)	CART2-84/2100-S/S	78586	15.6
	SAC Repl Cartridge S/S 2400 mm (Dual)	CART2-96/2400-S/S	78587	17.8
	SAC Repl Cartridge S/S 3000 mm (Dual)	CART2-120/3000-S/S	78588	22.6

U.S. Patent No. 7,987,966; 8,757,360; 8,312,986;
8,640,856; 9,090,405; 9,085,419

Stock items (non-shaded) refer to (*) for specific lead time, if not specified, standard lead time applies.

Non-stock items (shaded) please contact Flexco for dispatch options and lead times.

Replacement Parts List

MHS SAC (Stainless Steel)
HD® Secondary Cleaner
 with Service Advantage Cartridge™

Replacement Parts (continued)

REF	DESCRIPTION	ORDERING NUMBER	ITEM CODE	WT. KG.
3	C-Tip	CT6	74535	0.4
3a	S/S V-Tip* (for vulcanised belts only)	RVT6-S/S	76205	0.4
4	PowerFlex™ Cushion, S/S*	SPFC-S/S	79201	0.9
5	SST HD® Mounting Base Kit, S/S*	STHDMK2-S/S	77634	4.6
6a	SST Spring - White S/S (1 ea.)	STS-W-S/S	77630	0.2
6b	SST Spring - Silver S/S (1 ea.)	STS-S-S/S	77631	0.4
6c	SST Spring - Black S/S (1 ea.)	STS-B-S/S	77632	0.5
7	SST Adj Rod Kit*(incl. 1 rod, 2 nuts, 2 bushings, 1 washer) for belts 450-1500 mm	STAK	75847	1.3
7a	SST HD Adj Rod Kit*(incl. 1 rod, 2 nuts, 2 HD bushings, 1 washer) for belts 1800-2100mm	STAKHD	75892	1.4
8	SST HD Torsion Pole Mount S/S* (1 ea.)	STHDPM2-S/S	77633	6.8
9	SST Bushing Kit - White/Silver	SSTBK-W	76636	0.1
9a	SST Bushing Kit - Black	SSTBK-B	76637	0.1
10	ST Slide Guide Kit	STGK2	77635	0.5
-	SST HD Cartridge Tensioner S/S - White (includes 1 ea. item 5, 6a, 7, 9) for belts 450-750 mm	SST1HDM-W-S/S	78394	13.7
-	SST HD Cartridge Tensioner S/S - Silver (includes 1 ea. item 5, 6b, 7, 9) for belts 900-1500 mm	SST1HDM-S-S/S	78395	13.9
-	SST HD Cartridge Tensioner S/S - Black (includes 1 ea. item 5, 6c, 7a, 9a) for belts 1800-2100 mm	SST1HDM-B-S/S	78396	14.1
11	CST HD Mounting Base Kit S/S*	CSTHDMK-S/S	78384	3.9
12a	CST Spring - White S/S (1 ea.) for belts 450-750 mm	CTS-W-S/S	78385	0.2
12b	CST Spring - Silver S/S (1 ea.) for belts 900-1500 mm	CTS-S-S/S	78386	0.2
12c	CST Spring - Black S/S (1 ea.) for belts 1800-2100 mm	CTS-B-S/S	78387	0.3
12d	CST Spring - Gold S/S (1 ea.) for belts 2400-3000 mm	CTS-G-S/S	78388	0.4
13	CST Adj Rod Kit (incl. 2 rods, 4 nuts, 4 bushings, 2 washers)	CSTAK	77031	1.5
14	CST HD Torsion Pole Mount S/S* (1 ea.)	CSTHDPM-S/S	78389	7.4
15	CST Bushing Kit (includes 4 bushings)	CSTBK	77037	0.1
-	CST HD Cartridge Tensioner S/S - White (incl. 1 ea. item 11,13,14 and 2 ea. item 12a) for belts 450-750 mm	CST1HDM-W-S/S	78390	13.7
-	CST HD Cartridge Tensioner S/S - Silver (incl. 1 ea. item 11,13,14 and 2 ea. item 12b) for belts 900-1500 mm	CST1HDM-S-S/S	78391	13.7
-	CST HD Cartridge Tensioner S/S - Black (includes 1 ea. item 11,13,14 and 2 ea. item 12c) for belts 1800-2100 mm	CST1HDM-B-S/S	78392	13.7
-	CST HD Cartridge Tensioner S/S - Gold (includes 1 ea. item 11,13,14 and 2 ea. item 12d) for belts 2400-3000 mm	CST1HDM-G-S/S	78393	13.9
16	SAC Removal Knuckle	SACRKN	77882	1.5
17	SAC Removal Handle S/S	SACRH-S/S	78397	1.4
18	SAC Handle Lock Plate S/S	SACRHL-S/S	78398	0.8
19	Knuckle Retainer Pin S/S	SACKRP-S/S	78399	0.1
-	SAC Removal Kit S/S (includes 1 ea. items 16,17,18,19)	SACRKT-S/S	78401	4.1
20	SAC Chute Seal Kit	SACSK	77052	1.8
21	SAC Chute Seal Replacement Cover	SACSRC	77065	0.2
22	SAC Cartridge Tip Alignment Tool (Dual)	SAC2-TIP-TL	77866	1.1

U.S. Patent No. 7,987,966; 8,757,360; 8,312,986;
 8,640,856; 9,090,405; 9,085,419

Stock items (non-shaded) refer to (*) for specific lead time, if not specified, standard lead time applies.

Non-stock items (shaded) please contact Flexco for dispatch options and lead times.

Specifications & Guidelines

MHS SAC
HD® Secondary Cleaner
 with Service Advantage Cartridge™

Pole Length Specifications*

VERSION	CLEANER SIZE mm	BLADE WIDTH mm	POLE LENGTH mm	MAXIMUM CONVEYOR SPAN mm
Single	600	600	1950	1650
	750	750	2100	1800
	900	900	2250	1950
	1050	1050	2400	2100
	1200	1200	2550	2250
	1350	1350	2700	2400
	1500	1500	2850	2550
Dual	1500	1500	3000	2700
	1800	1800	3300	3000
	2100	2100	3600	3300
	2400	2400	3900	3600
	3000	3000	4500	4200

*For special extra long pole length requirements a Pole Extender Kit (#76024) is available that provides 750 mm of extended pole length. Pole Diameter - 73 mm

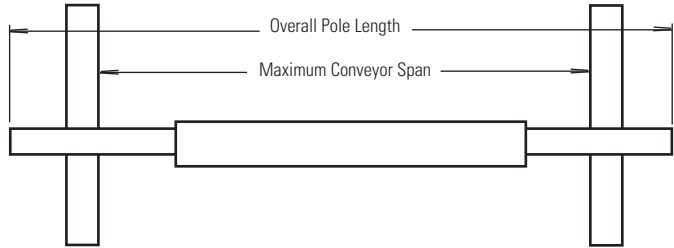

Clearance Guidelines for Installation

VERSION	HORIZONTAL CLEARANCE REQUIRED mm	VERTICAL CLEARANCE REQUIRED mm
Single	114	279
Dual	114	318

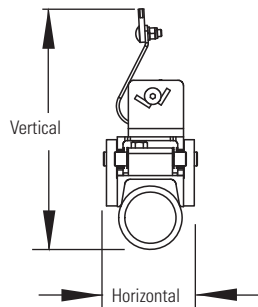

Aluminum Content

ALUMINUM ALLOY TYPE	PERCENT	
	MG MAGNESIUM	TI TITANIUM
6061	1.0%	0.0%

Spring Length Chart for SST Spring Tensioner (mm)

BLADE WIDTH	WHITE SPRING	SILVER SPRING	BLACK SPRING
600	78	99	N/A
750	72	97	N/A
900	N/A	94	98
1050	N/A	91	95
1200	N/A	88	93
1350	N/A	86	91
1500	N/A	83	89
1800	N/A	N/A	84

Shading indicates preferred spring option

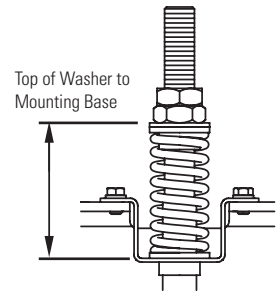

Spring Length Chart for CST Spring Tensioner (mm)

BLADE WIDTH	WHITE SPRING	SILVER SPRING	BLACK SPRING	GOLD SPRING
600	78	99	N/A	N/A
750	72	97	N/A	N/A
900	N/A	94	98	N/A
1050	N/A	91	95	N/A
1200	N/A	88	93	N/A
1350	N/A	86	91	N/A
1500	N/A	83	89	103
1800	N/A	N/A	84	101
2100	N/A	N/A	80	99
2400	N/A	N/A	N/A	97
3000	N/A	N/A	N/A	93

Shading indicates preferred spring option

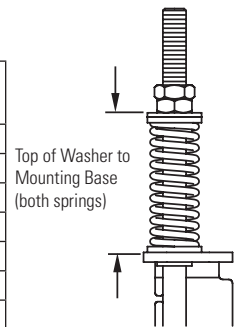

Specifications:

- Maximum Belt Speed 6M/sec
- Temperature Rating..... -35°C to 82°C
- Usable Blade Wear Length..... 9mm
- Blade Materials..... C-Tip: Impact Resistant Tungsten Carbide (works with mechanical fasteners)
 V-Tip: Long Life Tungsten Carbide (for vulcanised belts only)
- Available for Belt Widths..... 600 to 3000 mm. Other sizes available upon request.

U.S. Patent No. 7,987,966; 8,757,360; 8,312,986;
 8,640,856; 9,090,405; 9,085,419

Product Ordering Information

MHS SAC BT HD® Secondary Cleaner with Service Advantage Cartridge™ & Bolt Tensioner

MHS SAC Secondary with V-Tips*

BELT WIDTH mm	ORDERING NUMBER	ITEM CODE	WT. KG.
600	MHS-600BTV-SAC	78007	61.4
750	MHS-750BTV-SAC	78008	66.4
900	MHS-900BTV-SAC	78009	71.6
1050	MHS-1050BTV-SAC	78010	77.2
1200	MHS-1200BTV-SAC	78011	82.0
1350	MHS-1350BTV-SAC	78012	87.1
1500	MHS-1500BTV-SAC	78013	92.4
1800	MHS-1800BTV-SAC	78014	102.7
1500	MHS-1500BTV-2SAC	78015	105.2
1800	MHS-1800BTV-2SAC	78016	120.7
2100	MHS-2100BTV-2SAC	78017	131.4
2400	MHS-2400BTV-2SAC	78018	142.0
3000	MHS-3000BTV-2SAC	78019	165.0

*NOTE: V-Tips can be used ONLY on vulcanised belts.

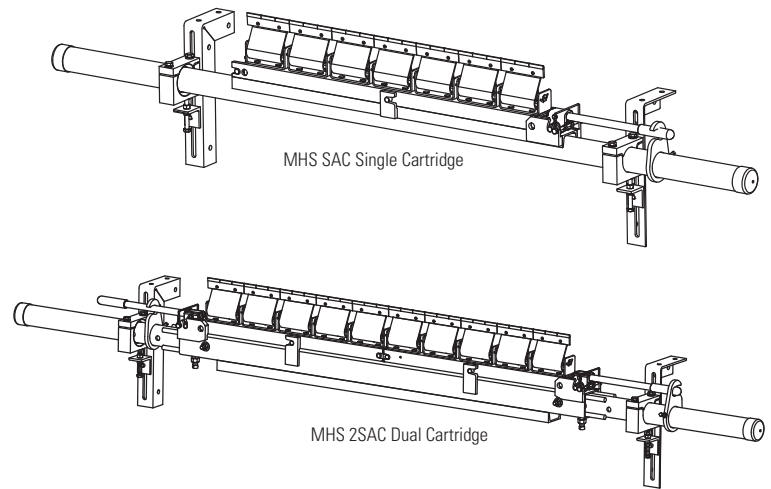

MHS SAC Stainless Steel Secondary with V-Tips*

BELT WIDTH mm	ORDERING NUMBER	ITEM CODE	WT. KG.
600	MHS-600BTV-SAC-S/S	78316	61.4
750	MHS-750BTV-SAC-S/S	78317	66.4
900	MHS-900BTV-SAC-S/S	78318	71.6
1050	MHS-1050BTV-SAC-S/S	78319	77.2
1200	MHS-1200BTV-SAC-S/S	78320	82.0
1350	MHS-1350BTV-SAC-S/S	78321	87.1
1500	MHS-1500BTV-SAC-S/S	78322	92.4
1800	MHS-1800BTV-SAC-S/S	78323	102.7
1500	MHS-1500BTV-2SAC-S/S	78324	105.2
1800	MHS-1800BTV-2SAC-S/S	78325	120.7
1950	MHS-1950BTV-2SAC-S/S	66255	126.0
2100	MHS-2100BTV-2SAC-S/S	78326	131.4
2400	MHS-2400BTV-2SAC-S/S	78327	142.0
3000	MHS-3000BTV-2SAC-S/S	78328	165.0

*NOTE: V-Tips can be used ONLY on vulcanised belts.

Replacement Tips

ORDERING NUMBER	ITEM CODE	WT. KG.
RSA150 (V-Tip)	73628	0.4

Tips Required Per Cleaner Size

BELT WIDTH mm	BLADE COVERAGE mm	V-TIPS REQUIRED
600	600	4
750	750	5
900	900	6
1050	1050	7
1200	1200	8
1350	1350	9
1500	1500	10
1800	1800	12
2100	2100	14
2400	2400	16
3000	3000	20

Product Notes:

- Patent-pending Service Advantage Cartridge™ allows for easy removal in even the dirtiest conditions.
- Heavy-duty design to deliver maximum cleaning efficiency on the most demanding, abusive beltlines.
- Pole Length: Belt width plus 1350mm (single cartridge cleaners); Belt width plus 1500 mm (dual cartridge cleaners).
- Patented PowerFlex™ cushion design to maintain continuous blade-to-belt contact and quick relief from passing mechanical splices.
- C-Tips are for mechanically fastened or vulcanised belts. V-Tips are for vulcanised belts only.
- Visual Blade Tension Check: Measure the tension spring and refer to Spring Length Chart on mounting base for the correct length for best cleaning performance.
- Tensioner mounting brackets included for fast and easy installation.
- Cartridge Removal Kit included for easy removal of the cartridge.

U.S. Patent No. 7,987,966; 8,757,360; 8,312,986;
8,640,856; 9,090,405; 9,085,419

Stock items (non-shaded) refer to (*) for specific lead time, if not specified, standard lead time applies.

Non-stock items (shaded) please contact Flexco for dispatch options and lead times.

Product Ordering Information

MHS SAC BT HD® Secondary Cleaner with Service Advantage Cartridge™ & Bolt Tensioner

MHS SAC Cartridge Kits with V-Tips*

BELT WIDTH mm	ORDERING NUMBER	ITEM CODE	WT. KG.
600	MHS-CARK-V24/600	77937	13.3
750	MHS-CARK-V30/750	77938	15.9
900	MHS-CARK-V36/900	77939	18.5
1050	MHS-CARK-V42/1050	77940	21.1
1200	MHS-CARK-V48/1200	77941	23.7
1350	MHS-CARK-V54/1350	77942	26.3
1500	MHS-CARK-V60/1500	77943	28.9
1800	MHS-CARK-V72/1800	77944	34.2
1500	MHS-CARK2-V60/1500	77950	31.8
1800	MHS-CARK2-V72/1800	77951	37.0
2100	MHS-CARK2-V84/2100	77952	42.2
2400	MHS-CARK2-V96/2400	77953	47.4
3000	MHS-CARK2-V120/3000	77954	57.9

*NOTE: V-Tips can be used ONLY on vulcanised belts.

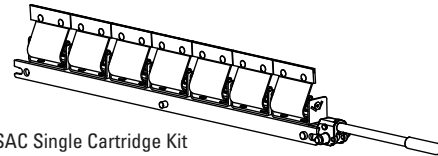

MHS SAC Single Cartridge Kit

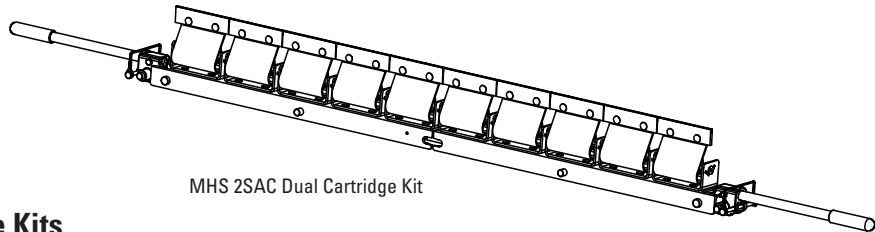

MHS 2SAC Dual Cartridge Kit

MHS SAC Stainless Steel Cartridge Kits with V-Tips*

BELT WIDTH mm	ORDERING NUMBER	ITEM CODE	WT. KG.
600	MHS-CARK-V24/600-S/S MVECKS/S	82841	13.3
750	MHS-CARK-V30/750-S/S MVECKS/S	82842	15.9
900	MHS-CARK-V36/900-S/S MVECKS/S	82843	18.5
1050	MHS-CARK-V42/1050-S/S MVECKS/S	82844	21.1
1200	MHS-CARK-V48/1200-S/S MVECKS/S	82845	23.7
1350	MHS-CARK-V54/1350-S/S MVECKS/S	82846	26.3
1500	MHS-CARK-V60/1500-S/S MVECKS/S	82847	28.9
1800	MHS-CARK-V72/1800-S/S MVECKS/S	82848	34.2
1500	MHS-CARK2-V60/1500-S/S MV2CKSS	82849	31.8
1800	MHS-CARK2-V72/1800-S/S MV2CKSS	82850	37.0
2100	MHS-CARK2-V84/2100-S/S MV2CKSS	82851	42.2
2400	MHS-CARK2-V96/2400-S/S MV2CKSS	82852	47.4
3000	MHS-CARK2-V120/3000-S/S MV2CKS	82853	57.9

*NOTE: V-Tips can be used ONLY on vulcanised belts.

Stock items (non-shaded) refer to (*) for specific lead time, if not specified, standard lead time applies.

Non-stock items (shaded) please contact Flexco for dispatch options and lead times.

U.S. Patent No. 7,987,966; 8,757,360; 8,312,986;
8,640,856; 9,090,405; 9,085,419

Replacement Parts List

MHS SAC BT (Mild Steel) HD® Secondary Cleaner with Service Advantage Cartridge™ & Bolt Tensioner

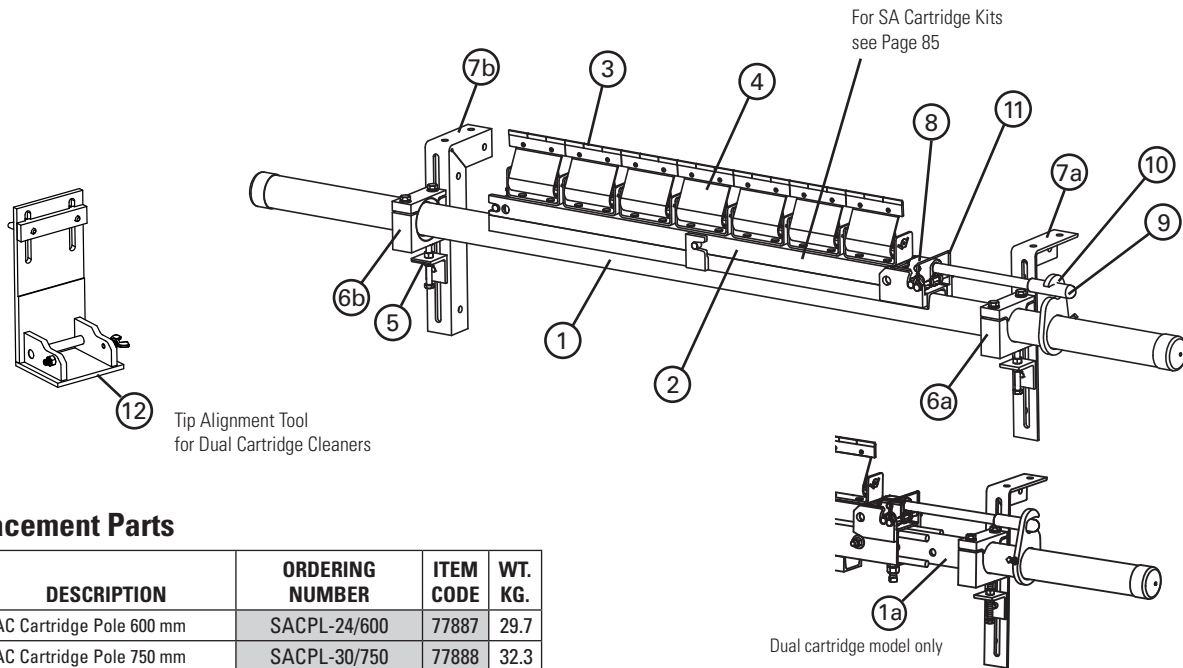

Replacement Parts

REF	DESCRIPTION	ORDERING NUMBER	ITEM CODE	WT. KG.
1	SAC Cartridge Pole 600 mm	SACPL-24/600	77887	29.7
	SAC Cartridge Pole 750 mm	SACPL-30/750	77888	32.3
	SAC Cartridge Pole 900 mm	SACPL-36/900	77889	35.0
	SAC Cartridge Pole 1050 mm	SACPL-42/1050	77890	37.6
	SAC Cartridge Pole 1200 mm	SACPL-48/1200	77891	40.3
	SAC Cartridge Pole 1350 mm	SACPL-54/1350	77892	42.9
	SAC Cartridge Pole 1500 mm	SACPL-60/1500	77893	45.6
	SAC Cartridge Pole 1800 mm	SACPL-72/1800	77894	50.9
	SAC Cartridge Center Pole 1500 mm (Dual)	SACPL2-60/1500	77895	35.1
	SAC Cartridge Center Pole 1800 mm (Dual)	SACPL2-72/1800	77896	40.6
	SAC Cartridge Center Pole 2100 mm (Dual)	SACPL2-84/2100	77897	46.2
	SAC Cartridge Center Pole 2400 mm (Dual)	SACPL2-96/2400	77898	51.8
	SAC Cartridge Center Pole 3000 mm (Dual)	SACPL2-120/3000	77899	64.5
1a	Extender Pole (for use with Dual Cartridge Center Pole)	MHP-EP	76392	24.5
2	SAC Repl Cartridge S/S 600 mm	CART-24/600-S/S	78576	4.5
	SAC Repl Cartridge S/S 750 mm	CART-30/750-S/S	78577	5.6
	SAC Repl Cartridge S/S 900 mm	CART-36/900-S/S	78578	6.7
	SAC Repl Cartridge S/S 1050 mm	CART-42/1050-S/S	78579	7.8
	SAC Repl Cartridge S/S 1200 mm	CART-48/1200-S/S	78580	8.9
	SAC Repl Cartridge S/S 1350 mm	CART-54/1350-S/S	78581	10.0
	SAC Repl Cartridge S/S 1500 mm	CART-60/1500-S/S	78582	11.3
	SAC Repl Cartridge S/S 1800 mm	CART-72/1800-S/S	78583	13.5
	SAC Repl Cartridge S/S 1500 mm (Dual)	CART2-60/1500-S/S	78584	11.2
	SAC Repl Cartridge S/S 1800 mm (Dual)	CART2-72/1800-S/S	78585	13.4
	SAC Repl Cartridge S/S 1950 mm (Dual)	CART2-78/1950-S/S	78635	14.5
	SAC Repl Cartridge S/S 2100 mm (Dual)	CART2-84/2100-S/S	78586	15.6
	SAC Repl Cartridge S/S 2400 mm (Dual)	CART2-96/2400-S/S	78587	17.8
	SAC Repl Cartridge S/S 3000 mm (Dual)	CART2-120/3000-S/S	78588	22.6

REF	DESCRIPTION	ORDERING NUMBER	ITEM CODE	WT. KG.
3	V-Tip* (for vulcanised belts only)	RSA150	73628	0.4
4	PowerFlex™ Cushion*	SPFC	79200	0.9
5	P/R Adjusting Bracket	PAB	75513	0.4
6a	Cradle Clamp Block RH	SMR-CCB-R73	A2843	1.2
6b	Cradle Clamp Block LH	SMR-CCB-L73	A2842	1.2
7a	Mounting Bracket Kit RH	PMBR	75519	3.8
7b	Mounting Bracket Kit LH	PMBL	75516	3.8
8	SAC Removal Knuckle	SACRKN	77882	1.5
9	SAC Removal Handle	SACRH	77883	1.4
10	SAC Handle Lock Plate	SACRHL	77884	0.8
11	Knuckle Retainer Pin	SACKRP	77885	0.1
-	SAC Removal Kit (incl. 1 ea. items 8,9,10,11)	SACRKT	77886	4.1
12	SAC Cartridge Tip Alignment Tool (Dual)	SAC2-TIP-TL	77866	1.1
-	Cradle Clamp Heavy-Duty Mounting Kit (incl. 2 ea. items 5, 7; 1 ea. items 6a, 6b)	CRHMK	62400	10.8

Stock items (non-shaded) refer to (*) for specific lead time, if not specified, standard lead time applies.
Non-stock items (shaded) please contact Flexco for dispatch options and lead times.

U.S. Patent No. 7,987,966; 8,757,360; 8,312,986; 8,640,856; 9,090,405; 9,085,419

Replacement Parts List

MHS SAC BT (Stainless Steel) HD[®] Secondary Cleaner with Service Advantage Cartridge™ & Bolt Tensioner

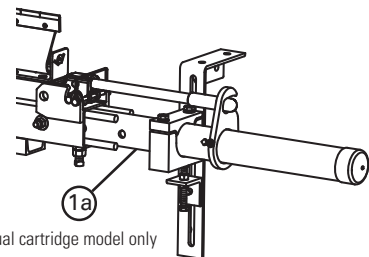
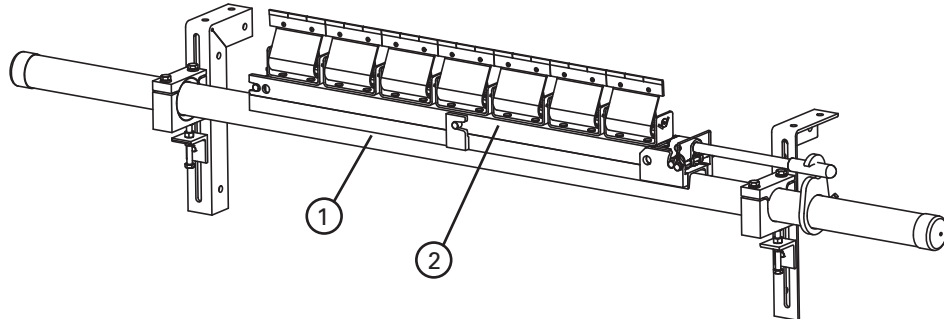

Replacement Parts

REF	DESCRIPTION	ORDERING NUMBER	ITEM CODE	WT. KG.
1	SAC S/S Cartridge Pole 600 mm	SACPL-24/600-S/S	78371	29.7
	SAC S/S Cartridge Pole 750 mm	SACPL-30/750-S/S	78372	32.3
	SAC S/S Cartridge Pole 900 mm	SACPL-36/900-S/S	78373	35.0
	SAC S/S Cartridge Pole 1050 mm	SACPL-42/1050-S/S	78374	37.6
	SAC S/S Cartridge Pole 1200 mm	SACPL-48/1200-S/S	78375	40.3
	SAC S/S Cartridge Pole 1350 mm	SACPL-54/1350-S/S	78376	42.9
	SAC S/S Cartridge Pole 1500 mm	SACPL-60/1500-S/S	78377	45.6
	SAC S/S Cartridge Pole 1800 mm	SACPL-72/1800-S/S	78378	50.9
	SAC S/S Cartridge Center Pole 1500 mm (Dual)	SACPL2-60/1500-S/S	78379	35.1
	SAC S/S Cartridge Center Pole 1800 mm (Dual)	SACPL2-72/1800-S/S	78380	40.6
	SAC S/S Cartridge Center Pole 1950 mm (Dual)	SACPL2-78/1950-S/S	78642	43.9
	SAC S/S Cartridge Center Pole 2100 mm (Dual)	SACPL2-84/2100-S/S	78381	46.2
	SAC S/S Cartridge Center Pole 2400 mm (Dual)	SACPL2-96/2400-S/S	78382	51.8
	SAC S/S Cartridge Center Pole 3000 mm (Dual)	SACPL2-120/3000-S/S	78383	64.5
1a	S/S Extender Pole (for use with S/S Dual Cartridge Center Pole)	MHP-EP-S/S	77599	24.5
2	SAC Repl Cartridge S/S 600 mm	CART-24/600-S/S	78576	4.5
	SAC Repl Cartridge S/S 750 mm	CART-30/750-S/S	78577	5.6
	SAC Repl Cartridge S/S 900 mm	CART-36/900-S/S	78578	6.7
	SAC Repl Cartridge S/S 1050 mm	CART-42/1050-S/S	78579	7.8
	SAC Repl Cartridge S/S 1200 mm	CART-48/1200-S/S	78580	8.9
	SAC Repl Cartridge S/S 1350 mm	CART-54/1350-S/S	78581	10.0
	SAC Repl Cartridge S/S 1500 mm	CART-60/1500-S/S	78582	11.3
	SAC Repl Cartridge S/S 1800 mm	CART-72/1800-S/S	78583	13.5

U.S. Patent No. 7,987,966; 8,757,360; 8,312,986;
8,640,856; 9,090,405; 9,085,419

Stock items (non-shaded) refer to (*) for specific lead time, if not specified, standard lead time applies.

Non-stock items (shaded) please contact Flexco for dispatch options and lead times.

Replacement Parts List

MHS SAC BT (Stainless Steel) HD® Secondary Cleaner with Service Advantage Cartridge™ & Bolt Tensioner

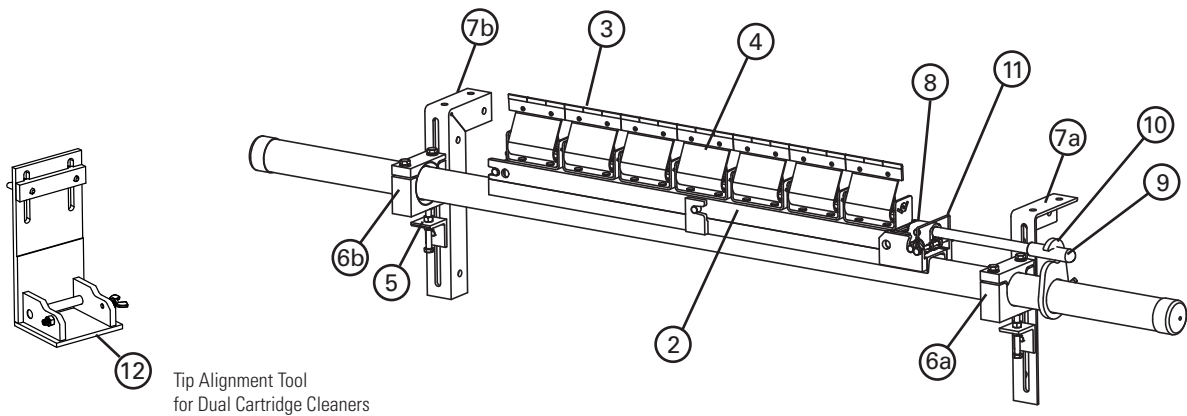

Tip Alignment Tool
for Dual Cartridge Cleaners

Replacement Parts (Continued)

REF	DESCRIPTION	ORDERING NUMBER	ITEM CODE	WT. KG.
2	SAC Repl Cartridge S/S 1500 mm (Dual)	CART2-60/1500-S/S	78584	11.2
	SAC Repl Cartridge S/S 1800 mm (Dual)	CART2-72/1800-S/S	78585	13.4
	SAC Repl Cartridge S/S 1950 mm (Dual)	CART2-78/1950-S/S	78635	14.5
	SAC Repl Cartridge S/S 2100 mm (Dual)	CART2-84/2100-S/S	78586	15.6
	SAC Repl Cartridge S/S 2400 mm (Dual)	CART2-96/2400-S/S	78587	17.8
	SAC Repl Cartridge S/S 3000 mm (Dual)	CART2-120/3000-S/S	78588	22.6
3	S/S V-Tip* (for vulcanised belts only)	RVT6-S/S	76205	0.4
4	PowerFlex™ Cushion S/S*	SPFC-S/S	79201	0.9
5	P/R Adjusting Bracket S/S	PAB-S/S	75515	0.4
6a	Cradle Clamp LH S/S CRDLBLK-LH	CRDLBLK-RH-S/S	A2825	1.2
6b	Cradle Clamp RH S/S CRDLBLK-RH	CRDLBLK-LH-S/S	A2826	1.2
7a	Mounting Bracket Kit RH S/S	PMBR-S/S	75521	3.8
7b	Mounting Bracket Kit LH S/S	PMBL-S/S	75518	3.8
8	SAC Removal Knuckle	SACRKN	77882	1.5
9	SAC Removal Handle S/S	SACRH-S/S	78397	1.4
10	SAC Handle Lock Plate S/S	SACRHL-S/S	78398	0.8
11	Knuckle Retainer Pin S/S	SACKRP-S/S	78399	0.1
-	SAC Removal Kit S/S (includes 1 ea. items 8,9,10,11)	SACRKT-S/S	78401	4.1
12	SAC Cartridge Tip Alignment Tool (Dual)	SAC2-TIP-TL	77866	1.1
-	Cradle Clamp Stainless Steel Heavy-Duty Mounting Kit (incl. 2 ea. item 5; incl. 1 ea. items 6a, 6b, 7a, 7b)	CRHMK-S/S	62095	10.8

U.S. Patent No. 7,987,966; 8,757,360; 8,312,986;
8,640,856; 9,090,405; 9,085,419

Stock items (non-shaded) refer to (*) for specific lead time, if not specified, standard lead time applies.

Non-stock items (shaded) please contact Flexco for dispatch options and lead times.

Specifications & Guidelines

MHS SAC BT HD® Secondary Cleaner with Service Advantage Cartridge™ & Bolt Tensioner

Pole Length Specifications*

VERSION	CLEANER SIZE mm	BLADE WIDTH mm	POLE LENGTH mm	MAXIMUM CONVEYOR SPAN mm
Single	600	600	1950	1650
	750	750	2100	1800
	900	900	2250	1950
	1050	1050	2400	2100
	1200	1200	2550	2250
	1350	1350	2700	2400
	1500	1500	2850	2550
Dual	1800	1800	3150	2850
	1500	1500	3000	2700
	1800	1800	3300	3000
	2100	2100	3600	3300
	2400	2400	3900	3600
	3000	3000	4500	4200

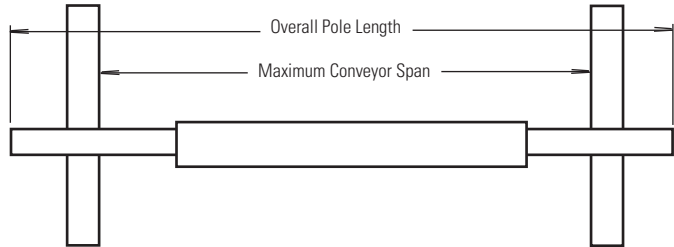

*For special extra long pole length requirements a Pole Extender Kit (#76024) is available that provides 750 mm of extended pole length.
Pole Diameter - 73 mm

Clearance Guidelines for Installation

VERSION	HORIZONTAL CLEARANCE REQUIRED mm	VERTICAL CLEARANCE REQUIRED mm
Single	114	279
Dual	114	318

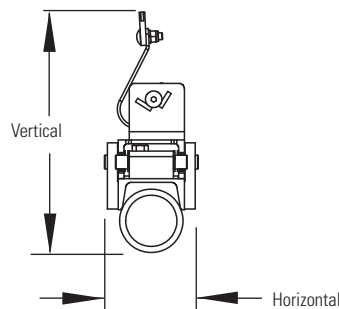

Specifications:

- Maximum Belt Speed5M/sec
- Temperature Rating-35°C to 82°C
- Usable Blade Wear Length.....9 mm
- Blade MaterialsC-Tip: Impact Resistant Tungsten Carbide (works with mechanical fasteners)
V-Tip: Long Life Tungsten Carbide (for vulcanised belts only)
- Available for Belt Widths600 to 3000 mm. Other sizes available upon request.

U.S. Patent No. 7,987,966; 8,757,360; 8,312,986;
8,640,856; 9,090,405; 9,085,419

Product Ordering Information

Spring Covers and Tensioner Lock

Spring Covers

ORDERING NUMBER	ITEM CODE	WT. KG.
SPG-CVR-A	77387	0.14
SPG-CVR-B	77388	0.14
SPG-CVR-C	77389	0.14
SPG-CVR-D	77390	0.18
SPG-CVR-E	77391	0.18
SPG-CVR-F	77392	0.14
SPG-CVR-G	77393	0.14
SPG-CVR-H	77741	0.14

Includes 1 spring cover

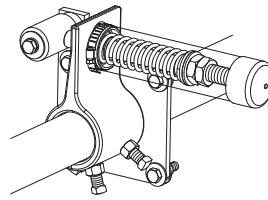
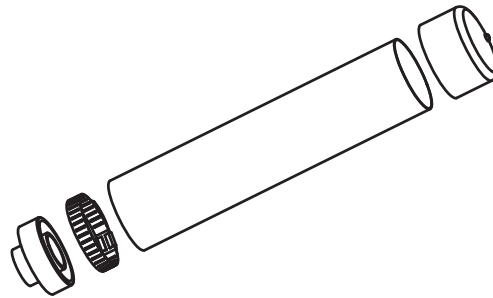

Spring cover on Primary Cleaner tensioner

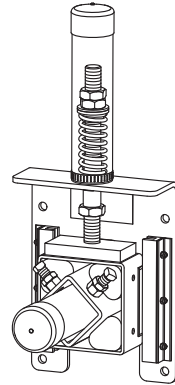

Spring cover on Secondary cleaner tensioner

Tensioner Lock

Designed to prevent tampering or unauthorized retensioning of the cleaner.

ORDERING NUMBER	ITEM CODE	WT. KG.
TEN-LOCK-KIT	77443	0.18

*For MSP, MMP, MHP, MHCP, H-Type® Primary Cleaners and MSS, MHS, MDWS Secondary Cleaners

Includes 1 tensioner lock

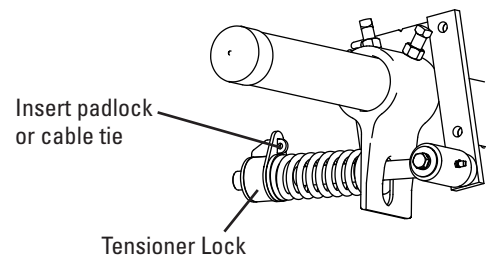
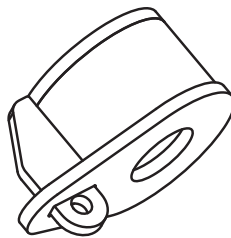

Tensioner Lock

(Primary Cleaner tensioner shown)

U.S. Patent No. D664,829

Stock items (non-shaded) refer to (*) for specific lead time, if not specified, standard lead time applies.

Non-stock items (shaded) please contact Flexco for dispatch options and lead times.

Product Ordering Information

U-Type® Secondary Cleaner with USTensioner



U-Type® with V-Blade (Tungsten Carbide)* and USTensioner, Mild Steel

CLEANER COMPLETE				REPLACEMENT V-BLADE		
BELT WIDTH mm	ORDERING NUMBER	ITEM CODE	WT. KG.	ORDERING NUMBER	ITEM CODE	WT. KG.
450	UTV450	77297	38.4	URVB18/450	76736	2.3
600	UTV600	77298	41.3	URVB24/600	76737	3.1
750	UTV750	77299	43.9	URVB30/750	76738	3.8
900	UTV900	77300	46.6	URVB36/900	76739	4.6
1050	UTV1050	77301	49.1	URVB42/1050	76740	5.3
1200	UTV1200	77302	51.9	URVB48/1200	76741	5.7
1350	UTV1350	77303	54.3	URVB54/1350	76742	6.8
1400	UTV1400	77304	55.1	URVB56/1400	77314	7.1
1500	UTV1500	77305	57.0	URVB60/1500	76743	7.6
1600	UTV1600	77306	59.0	URVB64/1600	77315	8.1
1800	UTV1800	77307	71.6	URVB72/1800	76744	9.2
2000	UTV2000	77308	75.3	URVB80/2000	77320	10.2
2100	UTV2100	77309	78.4	URVB84/2100	76745	10.7
2200	UTV2200	77310	81.7	URVB88/2200	77316	11.2
2400	UTV2400	77411	84.6	URVB94/2400	77421	12.0
2500	UTV2500	77412	87.1	URVB98/2500	77422	12.5

*NOTE: V-Blades (Tungsten Carbide) can be used on vulcanised belts and mechanically spliced belts ONLY IF the splice is skived (recessed into the belt's cover) (on solid plate splices the bolts must be ground).

CAUTION: The V-Blade CANNOT be used on belts with mechanical rip repair fasteners.

U-Type® with V-Blade (Tungsten Carbide)* and USTensioner, Stainless Steel

CLEANER COMPLETE				REPLACEMENT V-BLADE		
BELT WIDTH mm	ORDERING NUMBER	ITEM CODE	WT. KG.	ORDERING NUMBER	ITEM CODE	WT. KG.
450	UTV450-S/S	82707	17.0	URVB18/450	76736	2.3
600	UTV600-S/S	82708	18.2	URVB24/600	76737	3.1
750	UTV750-S/S	82709	19.6	URVB30/750	76738	3.8
900	UTV900-S/S	82710	21.7	URVB36/900	76739	4.6
1050	UTV1050-S/S	82711	23.1	URVB42/1050	76740	5.3
1200	UTV1200-S/S	82712	26.0	URVB48/1200	76741	5.7
1350	UTV1350-S/S	82713	27.7	URVB54/1350	76742	6.8
1400	UTV1400-S/S	82714	28.7	URVB56/1400	77314	7.1
1500	UTV1500-S/S	82715	31.0	URVB60/1500	76743	7.6
1600	UTV1600-S/S	82716	32.9	URVB64/1600	77315	8.1
1800	UTV1800-S/S	82717	36.4	URVB72/1800	76744	9.2
2000	UTV2000-S/S	82718	39.0	URVB80/2000	77320	10.2
2100	UTV2100-S/S	82719	41.7	URVB84/2100	76745	10.7
2200	UTV2200-S/S	82720	44.4	URVB88/2200	77316	11.2
2400	UTV2400-S/S	82721	47.1	URVB94/2400	77421	12.0
2500	UTV2500-S/S	82722	49.8	URVB98/2500	77422	12.5

*NOTE: V-Blades (Tungsten Carbide) can be used on vulcanised belts and mechanically spliced belts ONLY IF the splice is skived (recessed into the belt's cover) (on solid plate splices the bolts must be ground).

CAUTION: The V-Blade CANNOT be used on belts with mechanical rip repair fasteners.

Stock items (non-shaded) refer to (*) for specific lead time, if not specified, standard lead time applies.

Non-stock items (shaded) please contact Flexco for dispatch options and lead times.

U.S. Patent No. 7,950,519

Product Ordering Information

U-Type® Secondary Cleaner with J-Bolt Tensioner

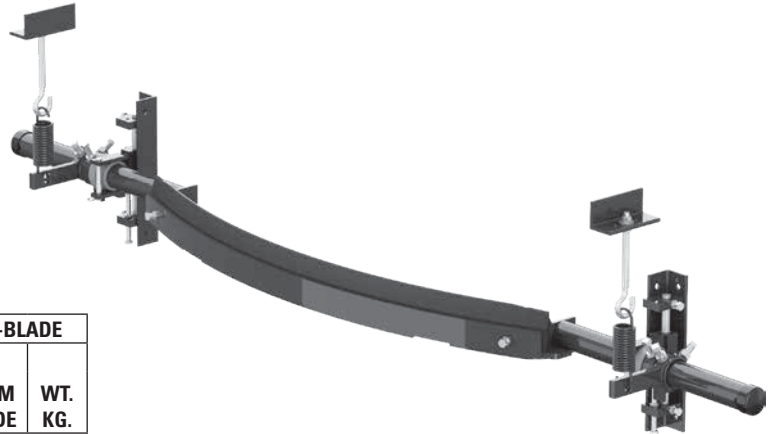

U-Type® with V-Blade (Tungsten Carbide)* and J-Bolt Tensioner, Mild Steel

CLEANER COMPLETE				REPLACEMENT V-BLADE		
BELT WIDTH mm	ORDERING NUMBER	ITEM CODE	WT. KG.	ORDERING NUMBER	ITEM CODE	WT. KG.
450	UTV450-J	77283	37.3	URVB18/450	76736	2.3
600	UTV600-J	77284	40.0	URVB24/600	76737	3.1
750	UTV750-J	77285	43.2	URVB30/750	76738	3.8
900	UTV900-J	77286	47.7	URVB36/900	76739	4.6
1050	UTV1050-J	77287	50.9	URVB42/1050	76740	5.3
1200	UTV1200-J	77288	57.3	URVB48/1200	76741	5.7
1350	UTV1350-J	77289	60.9	URVB54/1350	76742	6.8
1400	UTV1400-J	77290	63.2	URVB56/1400	77314	7.1
1500	UTV1500-J	77291	68.2	URVB60/1500	76743	7.6
1600	UTV1600-J	77292	72.3	URVB64/1600	77315	8.1
1800	UTV1800-J	77293	80.0	URVB72/1800	76744	9.2
2000	UTV2000-J	77294	85.9	URVB80/2000	77320	10.2
2100	UTV2100-J	77295	91.8	URVB84/2100	76745	10.7
2200	UTV2200-J	77296	97.7	URVB88/2200	77316	11.2
2400	UTV2400-J	77413	103.6	URVB94/2400	77421	12.0
2500	UTV2500-J	77414	109.6	URVB98/2500	77422	12.5

*NOTE: V-Blades (Tungsten Carbide) can be used on vulcanised belts and mechanically spliced belts ONLY IF the splice is skived (recessed into the belt's cover) (on solid plate splices the bolts must be ground).

CAUTION: The V-Blade CANNOT be used on belts with mechanical rip repair fasteners.

U-Type® with V-Blade (Tungsten Carbide)* and J-Bolt Tensioner, Stainless Steel

CLEANER COMPLETE				REPLACEMENT V-BLADE		
BELT WIDTH MM	ORDERING NUMBER	ITEM CODE	WT. KG.	ORDERING NUMBER	ITEM CODE	WT. KG.
450	UTV450J-S/S	77259	37.3	URVB18/450	76736	2.3
600	UTV600J-S/S	77260	40.0	URVB24/600	76737	3.1
750	UTV750J-S/S	77261	43.2	URVB30/750	76738	3.8
900	UTV900J-S/S	77262	47.7	URVB36/900	76739	4.6
1050	UTV1050J-S/S	77263	50.9	URVB42/1050	76740	5.3
1200	UTV1200J-S/S	77264	57.3	URVB48/1200	76741	5.7
1350	UTV1350J-S/S	77265	60.9	URVB54/1350	76742	6.8
1400	UTV1400J-S/S	77266	63.2	URVB56/1400	77314	7.1
1500	UTV1500J-S/S	77267	68.2	URVB60/1500	76743	7.6
1600	UTV1600J-S/S	77268	72.3	URVB64/1600	77315	8.1
1800	UTV1800J-S/S	77269	80.0	URVB72/1800	76744	9.2
2000	UTV2000J-S/S	77270	85.9	URVB80/2000	77320	10.2
2100	UTV2100J-S/S	77271	91.8	URVB84/2100	76745	10.7
2200	UTV2200J-S/S	77272	97.7	URVB88/2200	77316	11.2
2400	UTV2400J-S/S	77417	103.6	URVB94/2400	77421	12.0
2500	UTV2500J-S/S	77418	109.6	URVB98/2500	77422	12.5

*NOTE: V-Blades (Tungsten Carbide) can be used on vulcanised belts and mechanically spliced belts ONLY IF the splice is skived (recessed into the belt's cover) (on solid plate splices the bolts must be ground).

CAUTION: The V-Blade CANNOT be used on belts with mechanical rip repair fasteners.

**Stainless Steel U-Type with C or F blade
available by special order**

Stock items (non-shaded) refer to (*) for specific lead time, if not specified, standard lead time applies.

Non-stock items (shaded) please contact Flexco for dispatch options and lead times.

U.S. Patent No. 7,950,519

www.flexco.com • toll-free phone: +1300-098-435



Replacement Parts List

U-Type® Secondary Cleaner with UST Tensioner or J-Bolt Tensioner

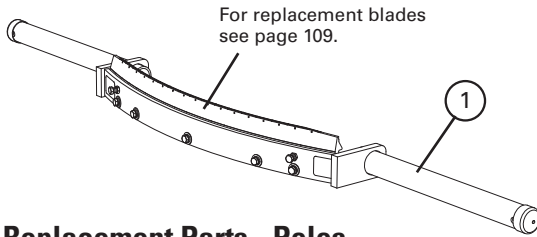

Replacement Parts - Poles

REF	DESCRIPTION	ORDERING NUMBER	ITEM CODE	WT. KG.
1	450mm Pole	USP18/450	82689	18.6
	600mm Pole	USP24/600	82690	20.1
	750mm Pole	USP30/750	82691	21.6
	900mm Pole	USP36/900	82692	23.2
	1050mm Pole	USP42/1050	82693	24.8
	1200mm Pole	USP48/1200	82694	26.3
	1350mm Pole	USP54/1350	82695	27.9
	1400mm Pole	USP56/1400	82696	28.4
	1500mm Pole	USP60/1500	82697	29.5
	1600mm Pole	USP64/1600	82698	30.5
	1800mm Pole	USP72/1800	82699	32.6
	2000mm Pole	USP80/2000	82700	34.6
	2100mm Pole	USP84/2100	82701	35.7
	2200mm Pole	USP88/2200	82702	36.7
	2400mm Pole	USP94/2400	82703	38.3
2500mm Pole	USP98/2500	82704	39.4	

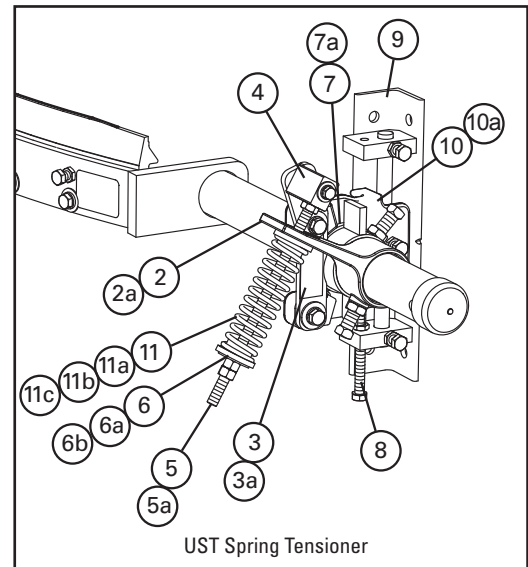

UST Spring Tensioner

Replacement Parts - UST Tensioner

REF	DESCRIPTION	ORDERING NUMBER	ITEM CODE	WT. KG.
2	Torque Arm Kit (1 ea.)	ESTAK	76406	1.6
2A	Torque Arm Kit HD (1 ea.)	C-PSTA	81045	5.2
3	Pivot Shaft Bracket Kit (1 ea.)	MUPSBK	82896	0.8
3A	Pivot Shaft Bracket Kit HD (1 ea.)	QMTPSBK-CN	82182	2.0
4	Pivot Block Kit (1 ea.)	MESPBL	87895	0.5
5	Pivot Rod Kit (1 ea.)	MESPKR	81896	0.5
5A	Pivot Rod Kit HD (1 ea.)	PTPK-MT	82343	2.0
6	EST Bush Kit P&S MET	MESBK-PS	82364	0.05
6A	QMT Bush Kit W&S MET	QMTBK-WS-MT	82175	0.05
6B	QMT Bush Kit G MET	QMTBK-GCN	82174	0.05
7	Standard Pole Bearing (1 ea.)	USPB2	79206	0.05
7A	HD Pole Bearing (1 ea.)	UHPB2	79207	0.1
8	Adjusting Bolt Kit (1 ea. incl. lock nut)	ABU	76788	0.1
9	Mounting Bracket Kit (1 ea. incl. L & R)	UMBK-M	82890	4.4
10	Slide Plate Kit (1 ea.)	USPK	76790	2.1
10A	HD Slide Plate Kit (1 ea.)	UHSPK-M	82887	2.4
11	Tension Spring Purple (1 ea.)	QMTS-P	75845	0.3
11A	Tension Spring Silver (1 ea.)	ESS-S	76412	0.5
11B	Tension Spring White (1 ea.)	PSTS-W	75898	0.8
11C	Tension Spring Gold (1 ea.)	QMT-G	76484	0.8
-	UST Spring Tensioner Mounting Kit* - Purple (Incl. 1 ea. Items 2, 3, 4, 5, 6, 8, 9, 10 & 11)	UST-P-MT	82897	9.5
-	UST Spring Tensioner Mounting Kit* - Silver (Incl. 1 ea. Items 2A, 4, 5A, 6A, 8, 9, 10A & 11A)	UST-S-MT	82898	13.1
-	Heavy-Duty UST Spring Tensioner* - White (Incl. 1 ea. Items 2A, 4, 5A, 6A, 8, 9, 10A & 11B)	UST-W-MT	82899	16.7
-	Heavy-Duty UST Spring Tensioner* - Gold (Incl. 1 ea. Items 2A, 4, 5A, 6A, 8, 9, 10A & 11C)	UST-G-MT	82900	16.7

*Hardware included

Note: For belt widths equal to and larger than 1600mm use heavy-duty components.

Stock items (non-shaded) refer to (*) for specific lead time, if not specified, standard lead time applies.

Non-stock items (shaded) please contact Flexco for dispatch options and lead times.

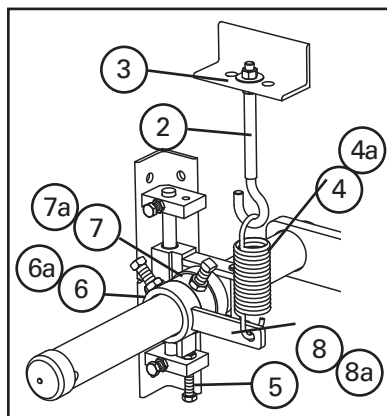

For use in changing UST Spring Tensioner to a J-Bolt Tensioner

Replacement Parts - J-bolt Tensioner

REF	DESCRIPTION	ORDERING NUMBER	ITEM CODE	WT. KG.
2	J-Bolt Kit* (incl. locknut and washer)	STJK-S/S	74417	0.3
3	J-Bolt Mount (1 ea.)	STJM	74775	1.4
4	450-1500mm Tension Spring (1 ea.)	STTS	74419	0.5
4a	1600 mm+ Tension Spring (1 ea.)	HDTSS	74502	0.7
5	Adjusting Bolt Kit (incl. locknut)	ABU	76788	0.5
6	450-1500 mm UHMW Bearing (1 ea.)	USPB	76786	0.5
6a	1600 mm+ UHMW Bearing (1 ea.)	UHPB	79206	0.5
7	450-1500 mm Stop Collar* (1 ea.)	SCU60	82812	0.9
7a	1600 mm+ Stop Collar* (1 ea.)	SCUHD	82813	0.9
8	450-1500 mm Adjusting Arm* (1 ea.)	HARK	73069	0.9
8a	1600mm+ Adjusting Arm* (1 ea.)	HDARK	77329	0.9
-	450-1500 mm Mounting Kit* (incl. 2 of items 2, 3, 4, 5, 6, 7, 8, 9 & incl. 1 of Item 5)	MMKU	77324	18.2
-	1600 mm+ Mounting Kit* (incl. 2 of items 2, 3, 4a, 6, 7a, 8a, 9a & incl. 1 of item 5)	MMKUHD	77327	19.6

*Hardware included

Replacement Parts List

Stainless Steel U-Type[®] Secondary Cleaner with UST Tensioner or J-Bolt Tensioner

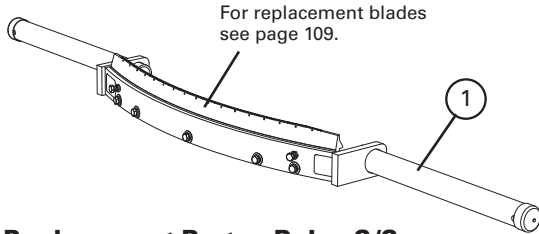

Replacement Parts - Poles S/S

REF	DESCRIPTION	ORDERING NUMBER	ITEM CODE	WT. KG.
1	450mm Pole	USP18/450-S/S	77339	18.6
	600mm Pole	USP24/600-S/S	77340	20.1
	750mm Pole	USP30/750-S/S	77341	21.6
	900mm Pole	USP36/900-S/S	77342	23.2
	1050mm Pole	USP42/1050-S/S	77343	24.8
	1200mm Pole	USP48/1200-S/S	77344	26.3
	1350mm Pole	USP54/1350-S/S	77345	27.9
	1400mm Pole	USP56/1400-S/S	77346	28.4
	1500mm Pole	USP60/1500-S/S	77347	29.5
	1600mm Pole	USP64/1600-S/S	77348	30.5
	1800mm Pole	USP72/1800-S/S	77349	32.6
	2000mm Pole	USP80/2000-S/S	77350	34.6
	2100mm Pole	USP84/2100-S/S	77351	35.7
	2200mm Pole	USP88/2200-S/S	77352	36.7
	2400mm Pole	USP94/2400-S/S	77419	38.3
2500mm Pole	USP98/2500-S/S	77420	39.4	

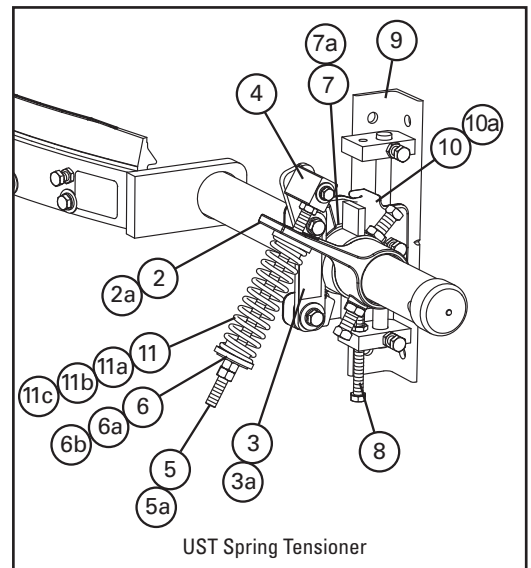

UST Spring Tensioner

Replacement Parts - UST Tensioner S/S

REF	DESCRIPTION	ORDERING NUMBER	ITEM CODE	WT. KG.
2	Torque Arm Kit (1 ea.)	ESTAK-SS	78849	1.6
2A	Torque Arm Kit HD (1 ea.)	MPSTA-S/S	82289	5.2
3	Pivot Shaft Bracket Kit (1 ea.)	MUPSBK-SS	82893	0.8
3A	Pivot Shaft Bracket Kit HD (1 ea.)	MQMTSBK-SS	82895	2.0
4	Pivot Block Kit (1 ea.)	MESPBL-SS	82892	0.5
5	Pivot Rod Kit (1 ea.)	MESPKR-SS	82894	0.5
5A	Pivot Rod Kit HD (1 ea.)	PTPK-MT-S/S	82342	2.0
6	EST Bush Kit P&S MET	MESBK-PS	82364	0.05
6A	QMT Bush Kit W&S MET	QMTBK-WS-MT	82175	0.05
6B	QMT Bush Kit G MET	QMTBK-GCN	82174	0.05
7	Standard Pole Bearing (1 ea.)	USPB2	79206	0.05
7A	HD Pole Bearing (1 ea.)	UHPB2	79207	0.1
8	Adjusting Bolt Kit (1 ea. incl. lock nut)	ABU	76788	0.1
9	Mounting Bracket Kit (1 ea. incl. L & R)	UMBK-SS-M	82891	4.4
10	Slide Plate Kit (1 ea.)	USPK-SS-M	82888	2.1
10A	HD Slide Plate Kit (1 ea.)	UHSPK-SS-M	82889	2.4
11	Tension Spring Purple (1 ea.)	QMTS-P-SS	77450	0.3
11A	Tension Spring Silver (1 ea.)	ESS-S-S/S	79288	0.5
11B	Tension Spring White (1 ea.)	QMTS-W-SS	77451	0.8
11C	Tension Spring Gold (1 ea.)	QMTS-G-SS	77452	0.8
-	UST Spring Tensioner Mounting Kit* - Purple (Incl. 1 ea. Items 2, 3, 4, 5, 6, 8, 9, 10 & 11)	UST-P-MT-SS	82901	9.5
-	UST Spring Tensioner Mounting Kit* - Silver (Incl. 1 ea. Items 2A, 4, 5A, 6A, 8, 9, 10A & 11A)	UST-S-MT-SS	82902	13.1
-	Heavy-Duty UST Spring Tensioner* - White (Incl. 1 ea. Items 2A, 4, 5A, 6A, 8, 9, 10A & 11B)	UST-W-MT-SS	82903	16.7
-	Heavy-Duty UST Spring Tensioner* - Gold (Incl. 1 ea. Items 2A, 4, 5A, 6A, 8, 9, 10A & 11C)	UST-G-MT-SS	82904	16.7

*Hardware included

Note: For belt widths equal to and larger than 1600mm use heavy-duty components.

Stock items (non-shaded) refer to (*) for specific lead time, if not specified, standard lead time applies.

Non-stock items (shaded) please contact Flexco for dispatch options and lead times.

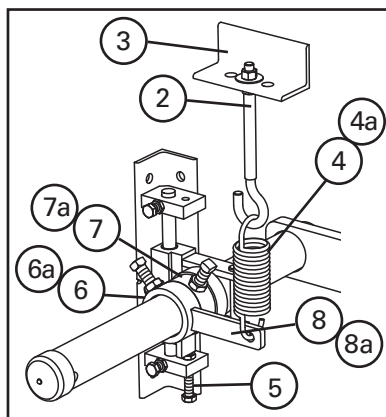

For use in changing UST Spring Tensioner to a J-Bolt Tensioner

Replacement Parts - J-bolt Tensioner S/S

REF	DESCRIPTION	ORDERING NUMBER	ITEM CODE	WT. KG.
2	J-Bolt Kit* (incl. locknut and washer)	STJK-S/S	74417	0.3
3	J-Bolt Mount (1 ea.)	STJM-S/S	75426	1.4
4	450-1500mm Tension Spring (1 ea.)	STTS-S/S	75585	0.5
4a	1600 mm+ Tension Spring (1 ea.)	HDTS-S/S	75586	0.7
5	Adjusting Bolt Kit (incl. locknut)	ABU	76788	0.5
6	450-1500 mm UHMW Bearing (1 ea.)	USPB	79206	0.5
6a	1600 mm+ UHMW Bearing (1 ea.)	UHPB	76787	0.5
7	450-1500 mm Stop Collar* (1 ea.)	SCU60-S/S	82810	0.9
7a	1600 mm+ Stop Collar* (1 ea.)	SCUHD-S/S	82811	0.9
8	450-1500 mm Adjusting Arm* (1 ea.)	HARK-S/S	77364	0.9
8a	1600mm+ Adjusting Arm* (1 ea.)	HDARK-S/S	77331	0.9
-	450-1500 mm Mounting Kit* (incl. 2 of items 2, 3, 4, 5, 6, 7, 8, 9 & incl. 1 of Item 5)	MMKU-SS	77357	18.2
-	1600 mm+ Mounting Kit* (incl. 2 of items 2, 3, 4a, 6, 7a, 8a, 9a & incl. 1 of item 5)	MMKUHD-SS	77358	19.6

*Hardware included

Replacement Parts List

U-Type® Secondary Cleaner with USTensioner



U-Type® V-Blades (Tungsten Carbide)*

BELT WIDTH mm	ORDERING NUMBER	ITEM CODE	WT. KG.
450	URVB18/450	76736	2.3
600	URVB24/600	76737	3.1
750	URVB30/750	76738	3.8
900	URVB36/900	76739	4.6
1050	URVB42/1050	76740	5.3
1200	URVB48/1200	76741	6.1
1350	URVB54/1350	76742	6.8
1400	URVB56/1400	77314	7.1
1500	URVB60/1500	76743	7.6
1600	URVB64/1600	77315	8.1
1800	URVB72/1800	76744	9.2
2000	URVB80/2000	77320	10.2
2100	URVB84/2100	76745	10.7
2200	URVB88/2200	77316	11.2
2400	URVB94/2400	77421	12.0
2500	URVB98/2500	77422	12.5

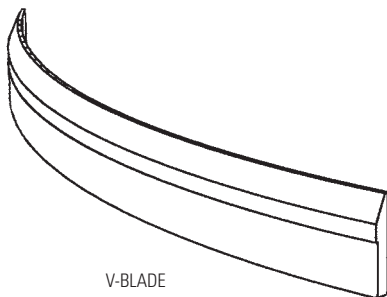
*NOTE: V-Blades (Tungsten Carbide) can be used on vulcanised belts. CAUTION: The V-Blade CANNOT be used on belts with mechanical rip repair fasteners. Use the F-Blade. Replacement blades also available in FRAS. Contact Flexco® for more information.



V-BLADE

 Stock items (non-shaded) refer to (*) for specific lead time, if not specified, standard lead time applies.
 Non-stock items (shaded) please contact Flexco for dispatch options and lead times.

U-Type® C-Blades (Impact-Resistant Tungsten Carbide)*

BELT WIDTH mm	ORDERING NUMBER	ITEM CODE	WT. KG.
450	URCB18/450	76748	2.3
600	URCB24/600	76749	3.1
750	URCB30/750	76750	3.8
900	URCB36/900	76751	4.6
1050	URCB42/1050	76752	5.3
1200	URCB48/1200	76753	6.1
1350	URCB54/1350	76754	6.8
1400	URCB56/1400	77317	7.1
1500	URCB60/1500	76755	7.6
1600	URCB64/1600	77318	8.1
1800	URCB72/1800	76756	9.2
2000	URCB80/2000	77321	10.2
2100	URCB84/2100	76757	10.7
2200	URCB88/2200	76319	11.2
2400	URCB94/2400	77448	12.0
2500	URCB98/2500	77449	12.5

*NOTE: C-Blades can be used on Flexco Solid Plate, mechanically fastened and vulcanised belts. Replacement blades also available in FRAS. Contact Flexco® for more information.

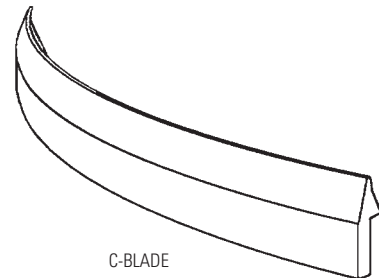

C-BLADE

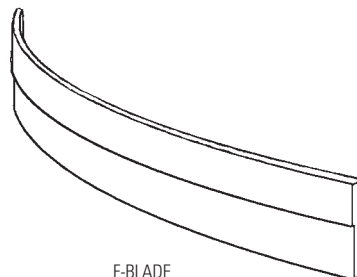

F-BLADE

U-Type® F-Blades (Purple Urethane)*

BELT WIDTH mm	ORDERING NUMBER	ITEM CODE	WT. KG.
450	UFB18	74448	1.4
600	UFB24	74449	1.8
750	UFB30	74450	2.3
900	UFB36	74451	2.7
1050	UFB42	74452	3.2
1200	UFB48	74453	3.6
1350	UFB54	74454	4.1
1500	UFB60	74455	4.6
1800	UFB72	74456	5.5
2100	UFB84	74460	6.4

*NOTE: F-Blades (Urethane) can be used on mechanically fastened belts and vulcanised belts.

U.S. Patent No. 7,950,519

U-Type® F-Blades FRAS (Blue Polyurethane)*

BELT WIDTH mm	ORDERING NUMBER	ITEM CODE	WT. KG.
450	UFB18-B	67327	1.4
600	UFB24-B	67328	1.8
750	UFB30-B	67329	2.3
900	UFB36-B	67330	2.7
1050	UFB42-B	67331	3.2
1200	UFB48-B	67332	3.6
1350	UFB54-B	67333	4.1
1500	UFB60-B	67334	4.6
1800	UFB72-B	67335	5.5
2100	UFB84-B	67336	6.4

*NOTE: F-Blades (Polyurethane) can be used on mechanically fastened belts and vulcanised belts.

Specifications & Guidelines

Pole Length Specifications

CLEANER SIZE mm	POLE LENGTH mm	MAXIMUM CONVEYOR SPAN mm
450	1375	1125
600	1575	1325
750	1825	1575
900	1975	1925
1050	2125	1875
1200	2375	2125
1350	2525	2275
1500	2650	2400
1800	2950	2700

Pole Diameter - 450-1500 mm cleaners: 60 mm
Pole Diameter - 1600 mm+ cleaners: 75 mm

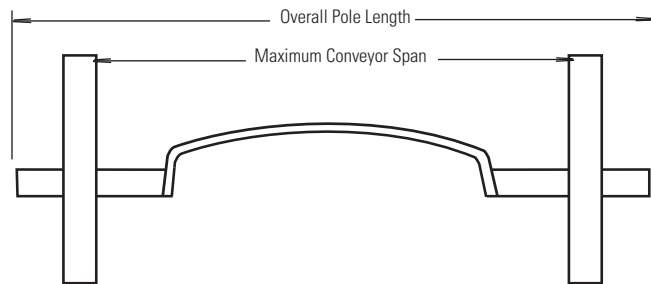

Clearance Guidelines For Installation

BELT WIDTH/ CLEANER SIZE mm	CLEARANCE REQUIRED mm
450	140
600	166
750	191
900	171
1050	217
1200	242
1350	242
1500	242
1800	261
2100	261

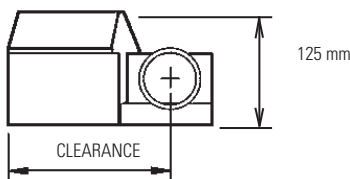

Spring Length Chart

(For Cleaners with UST Tensioners)

Blade Width mm	Purple Spring mm	Silver Spring mm	White Spring mm
450	154	160	162
600	148	148	160
750	140	156	158
900	136	152	156
1050	128	150	154
1200	N/A	146	152
1350	N/A	142	150
1500	N/A	140	150
1800	N/A	N/A	140
2100	N/A	N/A	136
2400	N/A	N/A	132

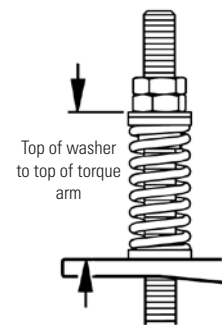

Spring Tensioner Guidelines

(For Cleaners with J-Bolt Tensioners)

- Spring gap = .7 mm minimum
- Gauge provided

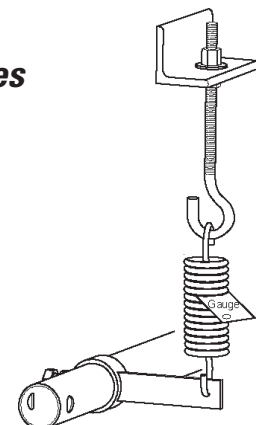

Specifications:

- Maximum Belt SpeedContact Flexco®
- Temperature Rating-35°C to 82°C
- Usable Blade Wear Length.....V-Blade and C-Blade - 9 mm; F-Blade - 44 mm
- Available for Belt Widths450 to 2500 mm.
Other sizes available upon request

U.S. Patent No. 7,950,519

Product Ordering Information

MDWS Secondary Cleaner DryWipe for Removing Water



MDWS Mild Steel Secondary Belt Cleaner with SST Tensioner

BELT WIDTH		ORDERING NUMBER	ITEM CODE	WT. KG	PRICE AUD
mm	in				
600	24	MDWS-24	75868	52.2	\$ 2,451.09
750	30	MDWS-30	75869	55.7	2,583.65
900	36	MDWS-36	75870	58.0	2,738.13
1050	42	MDWS-42	75871	62.7	2,870.68
1200	48	MDWS-48	75872	66.6	3,027.16
1350	54	MDWS-54	75873	70.1	3,163.73
1500	60	MDWS-60	75874	73.6	3,315.22
1800	72	MDWS-72	75875	80.6	3,607.28
2100	84	MDWS-84	76806	87.6	4,028.72
2400	96	MDWS-96	79063	94.7	4,589.58



MDWS Mild Steel Secondary Belt Cleaner with MST Tensioner

BELT WIDTH		ORDERING NUMBER	ITEM CODE	WT. KG	PRICE AUD
mm	in				
600	24	MDWS-MST-600	67559	52.2	\$ 2,226.09
750	30	MDWS-MST-750	67560	55.7	2,358.65
900	36	MDWS-MST-900	67561	58.0	2,513.13
1050	42	MDWS-MST-1050	67562	62.7	2,645.68
1200	48	MDWS-MST-1200	67563	66.6	2,802.16
1350	54	MDWS-MST-1350	67564	70.1	2,938.73
1500	60	MDWS-MST-1500	67565	73.6	3,090.22
1800	72	MDWS-MST-1800	67566	80.6	3,382.28
2100	84	MDWS-MST-2100	67567	87.6	3,803.72
2400	96	MDWS-MST-2400	67568	94.7	4,364.58

MDWS Stainless Steel Secondary Belt Cleaner with SST Tensioner

BELT WIDTH		ORDERING NUMBER	ITEM CODE	WT. KG	PRICE AUD
mm	in				
600	24	MDWS-600-S/S	67466	52.5	\$ 4,091.40
750	30	MDWS-750-S/S	67467	56.0	4,259.01
900	36	MDWS-900-S/S	67468	58.3	4,448.55
1050	42	MDWS-1050-S/S	67469	63.0	4,616.15
1200	48	MDWS-1200-S/S	67470	67.0	4,807.67
1350	54	MDWS-1350-S/S	67471	70.5	4,979.31
1500	60	MDWS-1500-S/S	67472	74.0	5,165.87
1800	72	MDWS-1800-S/S	67473	81.1	5,497.30
2100	84	MDWS-2100-S/S	67474	88.1	6,307.77
2400	96	MDWS-2400-S/S	67475	95.3	6,984.18

MDWS Stainless Steel Secondary Belt Cleaner with MST Tensioner

BELT WIDTH		ORDERING NUMBER	ITEM CODE	WT. KG	PRICE AUD
mm	in				
600	24	MDWS-MST-600-S/S	67476	42.5	\$ 3,056.40
750	30	MDWS-MST-750-S/S	67477	46.0	3,224.01
900	36	MDWS-MST-900-S/S	67478	48.3	3,413.55
1050	42	MDWS-MST-1050-S/S	67479	53.0	3,581.15
1200	48	MDWS-MST-1200-S/S	67480	57.0	3,772.67
1350	54	MDWS-MST-1350-S/S	67481	60.5	3,944.31
1500	60	MDWS-MST-1500-S/S	67482	64.0	4,130.87
1800	72	MDWS-MST-1800-S/S	67483	71.1	4,462.30
2100	84	MDWS-MST-2100-S/S	67484	78.1	5,272.77
2400	96	MDWS-MST-2400-S/S	67485	85.3	5,949.18

Product Notes:

- The ConShear™ "DryWipe" (DW) Blade is excellent for removing water from the belt. Use as the final cleaner in a cleaning system.
- Actual blade width is belt width plus 100mm (4"). The extra length ensures the water is removed from the belt.
- Pole Length: Belt width plus 1500mm (60") for cleaners up to 1500mm (60"), belt width plus 1350mm (54") for cleaners over 1500mm (60").
- Visual Blade Tension Check: Measure the tension spring and refer to the Spring Length Chart on mounting base for the correct length for best cleaning performance.

Stock items (non-shaded) refer to (*) for specific lead time, if not specified, standard lead time applies.

Non-stock items (shaded) please contact Flexco for dispatch options and lead times.

Replacement Parts List

MDWS
Secondary Cleaner
DryWipe for Removing Water

Replacement Poles

BELT WIDTH		MILD STEEL			STAINLESS STEEL		
		ORDERING NUMBER	ITEM CODE	WT. KG	ORDERING NUMBER	ITEM CODE	WT. KG
mm	in						
600	24	MSPP30	75804	46.0	MSPP30-S/S	77473	46.3
750	30	MSPP36	75805	50.5	MSPP36-S/S	77474	50.8
900	36	MSPP42	75806	55.5	MSPP42-S/S	77475	55.9
1050	42	MSPP48	75807	60.0	MSPP48-S/S	77476	60.4
1200	48	MSPP54	75808	64.0	MSPP54-S/S	77477	64.4
1350	54	MSPP60	75809	67.0	MSPP60-S/S	77478	67.4
1500	60	MSPP66	76695	76.0	MSPP66-S/S	77479	76.5
1800	72	DWP72	75883	90.0	DWP72-S/S	67409	90.6
2100	84	DWP84	76815	100.0	DWP84-S/S	67486	100.6
2400	96	DWP96	79060	116.0	DWP96-S/S	67487	110.7

MST Replacement Parts

DESCRIPTION		MILD STEEL			STAINLESS STEEL		
		ORDERING NUMBER	ITEM CODE	WT. KG.	ORDERING NUMBER	ITEM CODE	WT. KG.
Belt Width	Pole Length						
Tension Spring - White (1 ea.) for belts 450-750mm		STS-W	75846	0.2	STS-W-S/S	77630	0.2
Tension Spring - Silver (1 ea.) for belts 900-1350mm		STS-S	75843	0.4	STS-S-S/S	77631	0.4
Tension Spring - Black (1 ea.) for belts 1500-1800mm		STS-B	75844	0.5	STS-B-S/S	77632	0.5
Tension Spring - Gold (1 ea.) for belts over 2100mm		STS-G	78142	0.5	STS-G-S/S	79057	0.5
MST Bushing Kit (incl. 4 bushings)		MSTBBK	63067	0.1	MSTBBK	63067	0.1
MST Lock Pin		MSTLP	64930	0.1	MSTLP	64930	0.1
MST Adjusting Mechanism		MSTAM	79435	0.5	MSTAM-S/S	64931	0.5
MST HD Tensioner w/White Spring		MSTHD-W	79431	16.7	MSTHD-W-S/S	90181	16.7
MST HD Tensioner w/Silver Spring		MSTHD-S	79432	17.0	MSTHD-S-S/S	90182	17.0
MST HD Tensioner w/Black Spring		MSTHD-B	79433	17.3	MSTHD-B-S/S	90183	17.3
MST HD Tensioner w/Gold Spring		MSTHD-G	63020	17.3	MSTHD-G-S/S	90184	17.3

For 2100mm and 2400mm options, please contact Flexco for pricing and availability

SST Replacement Parts

DESCRIPTION	MILD STEEL			STAINLESS STEEL		
	ORDERING NUMBER	ITEM CODE	WT. KG.	ORDERING NUMBER	ITEM CODE	WT. KG.
SST HD® Mounting Base Kit* (includes 1 mounting base and 2 slide guides)	SSTHDMK	77870	4.6	STHDMK2-S/S	77634	4.6
SST Spring - White (1 ea.) for belts 450-750mm	STS-W	75846	0.2	STS-W-S/S	77630	0.2
SST Spring - Silver (1 ea.) for belts 900-1500mm	STS-S	75843	0.4	STS-S-S/S	77631	0.4
SST Spring - Black (1 ea.) for belts 1800-2100mm	STS-B	75844	0.5	STS-B-S/S	77632	0.5
SST Spring - Gold (1 ea.) for belts over 2100mm	STS-G	78142	0.7			
SST Adj Rod Kit* (incl. 1 rod, 2 nuts, 2 bushings, 1 washer) for belts 450-1500 mm	STAK	75847	1.3	STAK	75847	1.3
SST HD Adj Rod Kit* (incl. 1 rod, 2 nuts, 2 HD bushings, 1 washer) for belts 1800-2100mm	STAKHD	75892	1.4	STAKHD	75892	1.4
SST HD Torsion Pole Mount* (1 ea.)	SSTHDPM	77868	6.8	STHDPM2-S/S	77633	6.8
SST Bushing Kit - White/Silver	SSTBK-W	76636	0.1	SSTBK-W	76636	0.1
SST Bushing Kit - Black/Gold	SSTBK-B	76637	0.1	SSTBK-B	76637	0.1
ST Slide Guide Kit	STGK2	77635	0.5	STGK2	77635	0.5
SST HD Cartridge Tensioner - White (includes 1 ea. item 5, 9, 12, 14) for belts 450-750 mm	SST1HDM-W	78517	13.7	SST1HDM-W-S/S	78394	13.7
SST HD Cartridge Tensioner - Silver (includes 1 ea. item 6, 9, 12, 14) for belts 900-1500 mm	SST1HDM-S	78518	13.9	SST1HDM-S-S/S	78395	13.9
SST HD Cartridge Tensioner - Black (includes 1 ea. item 7, 10, 13, 14) for belts 1800-2100 mm	SST1HDM-B	78519	14.1	SST1HDM-B-S/S	78396	14.1
SST HD Cartridge Tensioner - Gold (includes 1 ea. item 8, 10, 13, 14) for belts over 2100 mm	SST1HDM-G	79069	14.3			
SST Hat Channel Kit	SSTHK	79070	0.7	SSTHK-S/S	79071	0.7

Replacement Parts List

MDWS
Secondary Cleaner
DryWipe for Removing Water

ConShear™ DW Replacement Blades

BELT WIDTH		ORDERING NUMBER	ITEM CODE	WT. KG
mm	in			
600	24	CDWB24	75884	5.8
750	30	CDWB30	75885	7.0
900	36	CDWB36	75886	8.3
1050	42	CDWB42	75887	9.5
1200	48	CDWB48	75888	10.8
1350	54	CDWB54	75889	12.0
1500	60	CDWB60	75890	13.2
1800	72	CDWB72	75891	15.7
2100	84	CDWB84	76942	18.4
2400	96	CDWB96	79062	21.0

Optional Mounting Kits

DESCRIPTION	ORDERING NUMBER	ITEM CODE	WT. KG
Blade Pins	MST LOCK PIN SS	G2309	0.1
Spring Mounting kit	SST1HDM-S Cartridge Tensioner	78518	13.5
Replacement Spring SST	STS-S Tension Spring	75843	0.4
Replacement Bush SST Kit	SSTBK-W Bushing Kit (Pair)	76636	9.1

Stock items (non-shaded) refer to (*) for specific lead time, if not specified, standard lead time applies.

Non-stock items (shaded) please contact Flexco for dispatch options and lead times.

Specifications & Guidelines

MDWS Secondary Cleaner DryWipe for Removing Water

CLEANER SIZE	BLADE WIDTH	POLE LENGTH	MAXIMUM CONVEYOR SPAN
mm	mm	mm	mm
600	700	2100	1700
750	850	2250	1850
900	1000	2400	2000
1050	1150	2550	2150
1200	1300	2700	2300
1350	1450	2850	2450
1500	1600	3000	2600
1800	1900	3150	2900
2100	2200	3450	3200
2400	2500	3750	3500

*For special extra long pole length requirements a Pole Extender Kit (#76024) is available that provides 750mm (30") of extended pole length. Pole Diameter – 73mm (2-7/8")

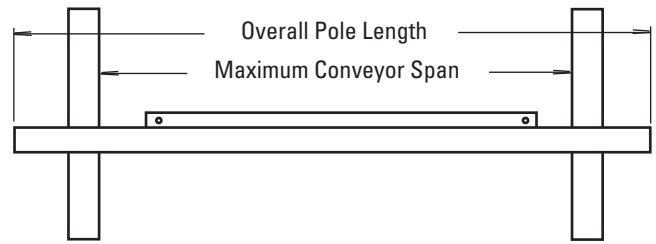

Clearance Guidelines for Installation

HORIZONTAL CLEARANCE REQUIRED		VERTICAL CLEARANCE REQUIRED	
mm	in.	mm	in.
100	4	250	10

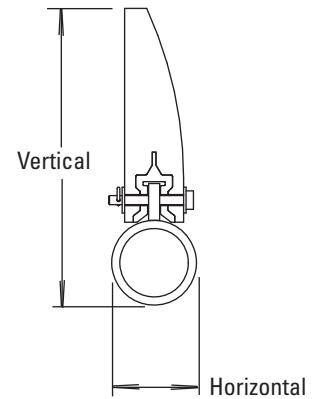

Spring Length Chart

with SST Spring Tensioner

Blade Width		White Spring		Silver Spring		Black Spring		Gold Spring	
mm	in.	mm	in.	mm	in.	mm	in.	mm	in.
450	18	86	3 3/8	102	4	N/A	N/A	N/A	N/A
600	24	79	3 1/8	98	3 7/8	N/A	N/A	N/A	N/A
750	30	73	2 7/8	95	3 3/4	N/A	N/A	N/A	N/A
900	36	N/A	N/A	95	3 3/4	98	3 7/8	N/A	N/A
1050	42	N/A	N/A	92	3 5/8	95	3 3/4	N/A	N/A
1200	48	N/A	N/A	89	3 1/2	92	3 5/8	N/A	N/A
1350	54	N/A	N/A	86	3 3/8	92	3 5/8	95	3 3/4
1500	60	N/A	N/A	83	3 1/4	89	3 1/2	95	3 3/4
1800	72	N/A	N/A	N/A	N/A	86	3 3/8	92	3 5/8
2100	84	N/A	N/A	N/A	N/A	79	3 1/8	89	3 1/2
2400	96	N/A	N/A	N/A	N/A	N/A	N/A	86	3 3/8
2700	108	N/A	N/A	N/A	N/A	N/A	N/A	89	3 1/2
3000	120	N/A	N/A	N/A	N/A	N/A	N/A	86	3 3/8

Shading indicates preferred spring option

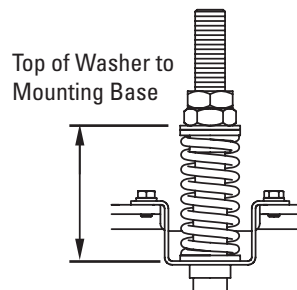

Shading indicates preferred spring option

PAT Pressure Chart

Blade Width		Blades	Psi
mm	in.		
600	24"	4	19#
750	30"	5	23#
900	36"	6	27#
1050	42"	7	31#
1200	48"	8	35#
1350	54"	9	39#
1500	60"	10	43#
1800	72"	12	51#
2100	84"	14	59#
2400	96"	15	67#

Specifications:

- Maximum Belt Speed5m/s (1000 FPM)
- Temperature Rating-35°C to 82°C (-30°F to 180°F)
- Usable Blade Wear Length113mm (4-1/2")
- Blade Height.....185 mm (7-1/4")
- BladePolyurethane with UHMW additive (softer durometer to squeegee water off and additive to enhance blade life)
- Available for Belt Widths600 to 2400 mm (24" to 96")
Other sizes available upon request.
- CEMA Cleaner RatingClass 4

U.S. Patent No. D482,508S

Product Ordering Information

Motorised Brush Cleaner



Motorised Brush Cleaner

Motorized Brush Cleaner

BELT WIDTH		ORDERING NUMBER	ITEM CODE	WT. KG.
mm	in.			
450	18	MBC-18	79494	62.1
600	24	MBC-24	79495	66.6
750	30	MBC-30	79496	68.3
900	36	MBC-36	79497	71.1
1050	42	MBC-42	79498	73.9
1200	48	MBC-48	79499	81.4
1350	54	MBC-54	79500	84.5
1500	60	MBC-60	79501	87.3
1800	72	MBC-72	79502	93.2
2100	84	MBC-84	79503	98.9

Replacement Brushes

BELT WIDTH		ORDERING NUMBER	ITEM CODE	WT. LBS.
mm	in.			
450	18	MBRD-18	79514	9.6
600	24	MBRD-24	79515	13.5
750	30	MBRD-30	79516	17.1
900	36	MBRD-36	79517	20.5
1050	42	MBRD-42	79518	23.7
1200	48	MBRD-48	79519	26.8
1350	54	MBRD-54	79520	30.7
1500	60	MBRD-60	79521	33.9
1800	72	MBRD-72	79522	41.0
2100	84	MBRD-84	79523	47.5

Optional Mounting Brackets (Pair)

ORDERING NUMBER	ITEM CODE	WT. LBS.
MBCDBK	79536	28.9

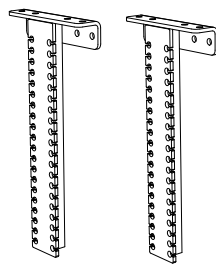

Product Notes:

- Spins opposite the belt direction for optimal cleaning.
- Uniquely patterned bristles aid in reducing material buildup and clogging.
- Adjustable tensioners allow easy brush-to-belt adjustment as the bristles wear.
- Works on mechanically spliced or vulcanised belts.

Stock items (non-shaded) refer to (*) for specific lead time, if not specified, standard lead time applies.

Non-stock items (shaded) please contact Flexco for dispatch options and lead times.

Specifications & Guidelines

Motorised Brush Cleaner

Specifications

Belt Speed	3.5M/sec (Up to 700 fpm)
Vertical and Horizontal Clearance	305mm (12")
Temperature Range	-30°C to 82°C (-20°F to 180°F)
Maximum Chevron or Cleat Height	13mm (1/2")
Bristle Length	83mm (3-1/4")
Overall Diameter	305mm (12")
Shaft Length	Belt Width plus 915mm (36")
Shaft Diameter	38mm (1-1/2")
Motor HP	1 HP cleaners 450-1050mm (1050mm)
	2 HP cleaners 1200-2100mm (48-84")
Motor voltage	230/400V

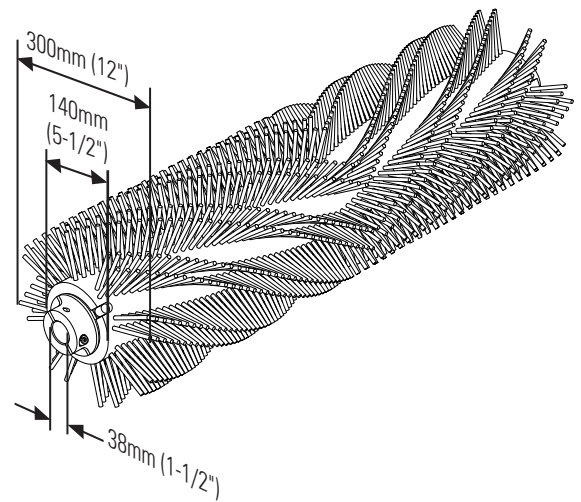
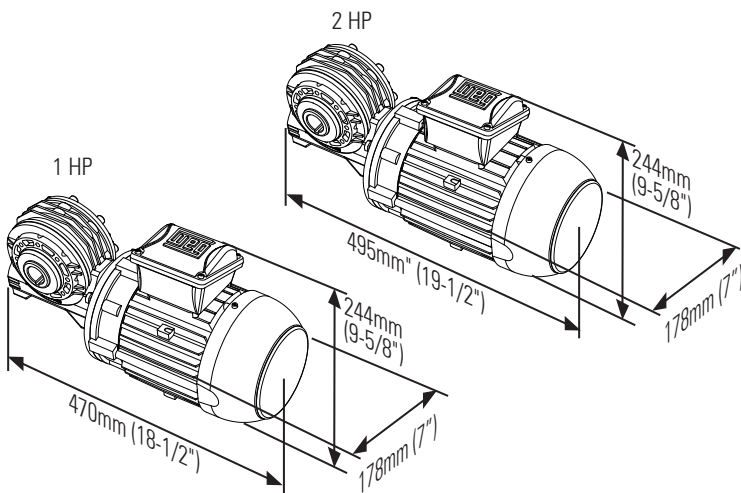
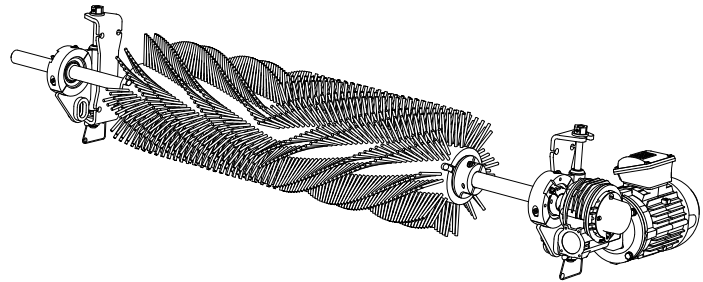

Replacement Parts List

Motorised Brush Cleaner

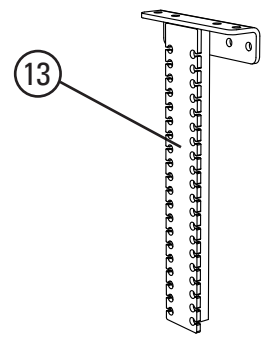
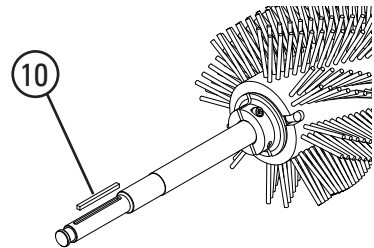
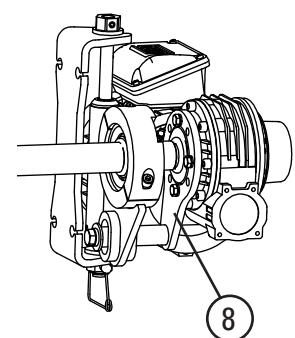
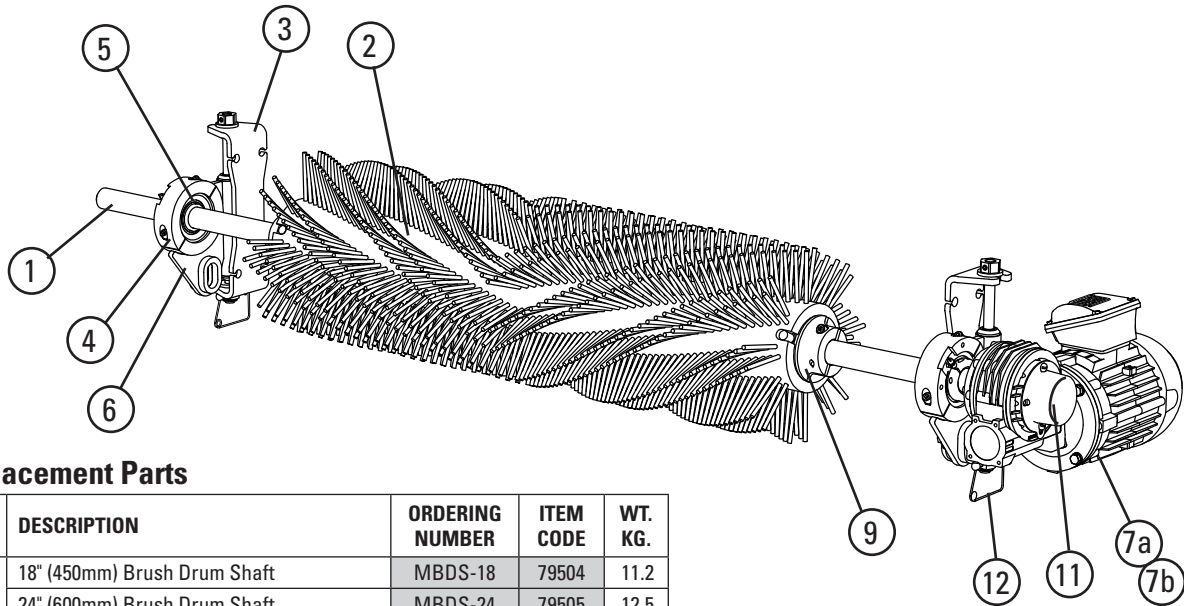

Replacement Parts

REF	DESCRIPTION	ORDERING NUMBER	ITEM CODE	WT. KG.
1	18" (450mm) Brush Drum Shaft	MBDS-18	79504	11.2
	24" (600mm) Brush Drum Shaft	MBDS-24	79505	12.5
	30" (750mm) Brush Drum Shaft	MBDS-30	79506	13.9
	36" (900mm) Brush Drum Shaft	MBDS-36	79507	15.3
	42" (1050mm) Brush Drum Shaft	MBDS-42	79508	16.6
	48" (1200mm) Brush Drum Shaft	MBDS-48	79509	18.0
	54" (1350mm) Brush Drum Shaft	MBDS-54	79510	19.3
	60" (1500mm) Brush Drum Shaft	MBDS-60	79511	20.7
	72" (1800mm) Brush Drum Shaft	MBDS-72	79512	23.4
84" (2100mm) Brush Drum Shaft	MBDS-84	79513	26.1	
2	18" (450mm) Replacement Brush Drum	MBRD-18	79514	4.4
	24" (600mm) Replacement Brush Drum	MBRD-24	79515	6.1
	30" (750mm) Replacement Brush Drum	MBRD-30	79516	7.8
	36" (900mm) Replacement Brush Drum	MBRD-36	79517	9.3
	42" (1050mm) Replacement Brush Drum	MBRD-42	79518	10.8
	48" (1200mm) Replacement Brush Drum	MBRD-48	79519	12.2
	54" (1350mm) Replacement Brush Drum	MBRD-54	79520	14.0
	60" (1500mm) Replacement Brush Drum	MBRD-60	79521	15.4
	72" (1800mm) Replacement Brush Drum	MBRD-72	79522	18.6
84" (2100mm) Replacement Brush Drum	MBRD-84	79523	21.6	
3	Brush Mounting Base* (1)	MBCM	79524	2.1
4	Brush Bearing Clamp* (1)	MBCBC	79525	0.9
5	Brush Cleaner Bearings (2)	MBCB	79526	3.3
6	Brush Bearing Mount* (1)	MBCBM	79528	4.4
7a	Gearmotor Assy, 1 HP for belts up to 42" (1050mm)	MBCM-1	79529	25.0
7b	Gearmotor Assy, 2 HP for belts 48" (1200mm) and up	MBCM-2	79530	29.5
8	Brush Cleaner Torque Arm* (1)	MBCTA	79531	1.1
9	Brush Locks* (2)	MBCBL	79532	4.3
10	Brush Motor Key Kit (1)	MBCMCK	79533	0.1
11	MBC Shaft End Cap* (1)	MBCCEC	79534	0.0
12	Tensioner Lock Pins (2)	STLP	79535	0.1
13	Brush Cleaner Drop Brackets* (2)	MBCDBK	79536	13.1
-	Brush Cleaner Adjusting Bracket (1) (incl. bearing and 1 ea. items 3,4,6,&12)	MBADB	79527	8.2

*Hardware Included

Stock items (non-shaded) refer to (*) for specific lead time, if not specified, standard lead time applies.

Non-stock items (shaded) please contact Flexco for dispatch options and lead times.

Product Ordering Information

Chevron Belt Cleaner

Chevron Belt Cleaner

BELT WIDTH		DRUM WIDTH		ORDERING NUMBER	ITEM CODE	WT. KG.
mm	in.	mm	in.			
450	18	450	18	CBC18	76668	34.9
600	24	600	24	CBC24	76669	40.0
750	30	750	30	CBC30	76670	45.0
900	36	900	36	CBC36	76671	50.1
1050	42	1050	42	CBC42	76672	55.1
1200	48	1200	48	CBC48	76673	60.2
1350	54	1350	54	CBC54	76674	65.2
1500	60	1500	60	CBC60	76675	70.3

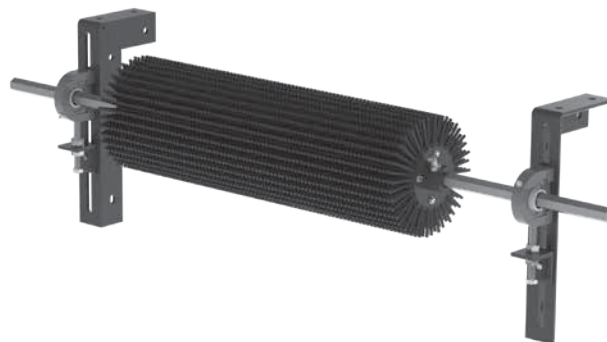

Replacement Parts

REF	DESCRIPTION	ORDERING NUMBER	ITEM CODE	WT. KG.
1	450 mm Drum Shaft	CBCS18	90537	6.9
	600 mm Drum Shaft	CBCS24	90538	7.7
	750 mm Drum Shaft	CBCS30	90539	8.6
	900 mm Drum Shaft	CBCS36	90540	9.5
	1050 mm Drum Shaft	CBCS42	90541	10.3
	1200 mm Drum Shaft	CBCS48	90542	11.2
	1350 mm Drum Shaft	CBCS54	90543	12.0
	1500 mm Drum Shaft	CBCS60	90544	12.9
2	Chevron Pillow Block*	CPB	76692	0.6
3	450 mm Replacement Drum w/Fingers*	CRDF18	90631	12.6
	600 mm Replacement Drum w/Fingers*	CRDF24	90632	16.8
	750 mm Replacement Drum w/Fingers*	CRDF30	90633	21.0
	900 mm Replacement Drum w/Fingers*	CRDF36	90634	25.2
	1050 mm Replacement Drum w/Fingers*	CRDF42	90635	29.4
	1200 mm Replacement Drum w/Fingers*	CRDF48	90636	33.6
	1350 mm Replacement Drum w/Fingers*	CRDF54	90637	37.8
	1500 mm Replacement Drum w/Fingers*	CRDF60	90638	42.0
4	75mm Replacement Finger Ring	CBC3R	90641	1.1
5	Mounting Bracket, Right	PMBR	75519	3.8
	Mounting Bracket, Left	PMBL	75516	3.8
6	Adjusting Bracket Kit* (1 ea.)	PAB	75513	0.9

*Hardware Included

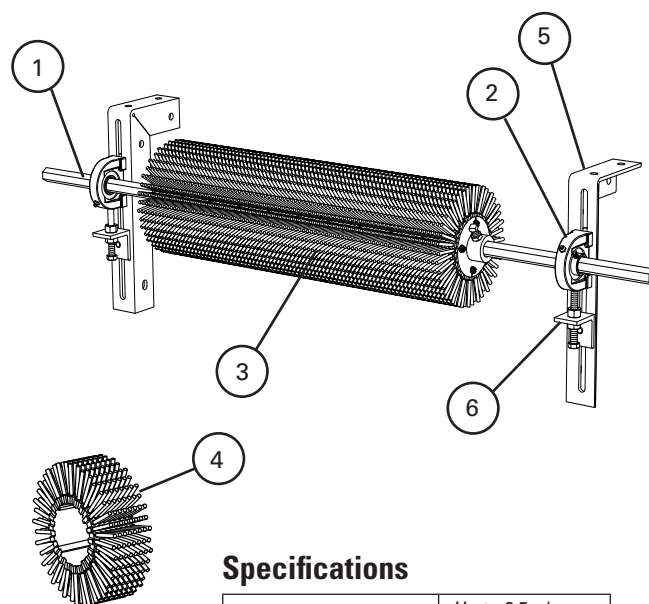

Specifications

Belt Speed	Up to 2.5m/s (500 fpm)
Vertical and Horizontal Clearance	250mm (10")
Temperature Range	-35°C to 82°C (-30°F to 180°F)
Maximum Chevron or Cleat Height	25mm (1")
Finger Length	50mm (2")
Rubber Durometer	45A
Overall Diameter	238mm (9-1/2")
Shaft Length	Belt Width plus 750mm (30")
Shaft	25mm (1") Hex
CEMA Cleaner Rating	Class 3

Product Notes:

- Free-rotating. Works only when the belt is running.
- Self-cleaning. Finger length, spacing and the rotary action allows carryback to fall free instead of clogging.
- Easy to install. Few parts and step-by-step instructions make the job simple.
- Long-wearing SBR rubber. Drum life ranges from 1 to 3 years depending upon the application conditions and the material being conveyed.
- Works on reversing belts.
- Finger rings can be replaced individually or all at once by replacing the drum.

Stock items (non-shaded) refer to (*) for specific lead time, if not specified, standard lead time applies.

Non-stock items (shaded) please contact Flexco for dispatch options and lead times.

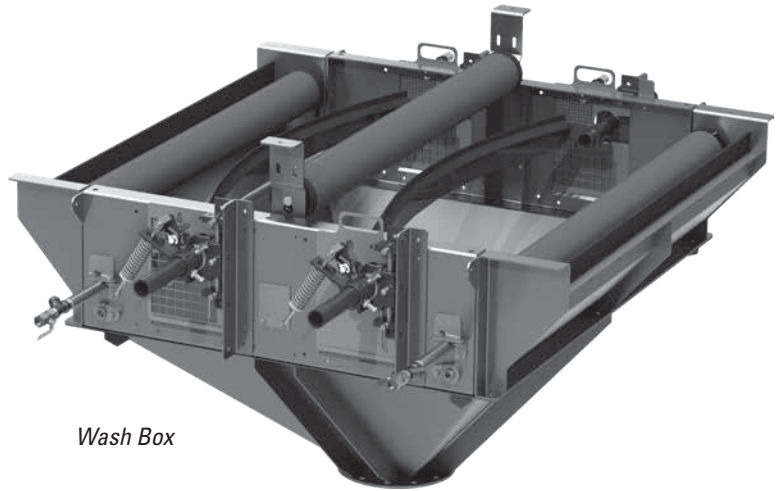

Wash Box

Wash Box

Belt Width	"A"	"B"	"C"	"D"	MASS	VOLUME
	Outside Conveyor Stringers (mm)	Mounting Hole Centres (mm)	Overall Width (mm)	Height to Outlet Flange (mm)	Excludes Cleaners & Rollers (kg)	Enclosed in Wash Box (m ³)
600	910	850	1,085	940	295	0.7
750	1,060	1,000	1,235	955	310	0.8
900	1,210	1,150	1,385	995	330	1.0
1,050	1,360	1,300	1,535	1,015	345	1.1
1,200	1,510	1,450	1,685	1,060	365	1.3
1,350	1,710	1,650	1,885	1,110	390	1.5
1,400	1,760	1,700	1,935	1,125	395	1.6
1,500	1,860	1,800	2,035	1,150	410	1.7
1,600	2,060	2,000	2,235	1,210	435	1.9
1,800	2,260	2,200	2,435	1,265	465	2.2
2,000	2,460	2,400	2,635	1,325	505	2.4

Product Notes:

- Please contact Flexco for pricing and lead time.
- The dimensions, mass and volumes shown here are nominal for a standard Flexco Wash Box and will be confirmed to suit each specific application.
- Each Stainless Steel Wash Box comes equipped with a combination of pressure rollers, spray bars and recovery system.
- The Wash Box is designed to accommodate any two secondary cleaners from the Flexco range, the belt cleaners are sold separately.
- Non-standard sizes available, please contact Flexco.

Stock items (non-shaded) refer to (*) for specific lead time, if not specified, standard lead time applies.

Non-stock items (shaded) please contact Flexco for dispatch options and lead times.

Product Ordering Information

Universal Lightweight Pole For use with H-Type, FMS, MHS and P-Type Cleaners

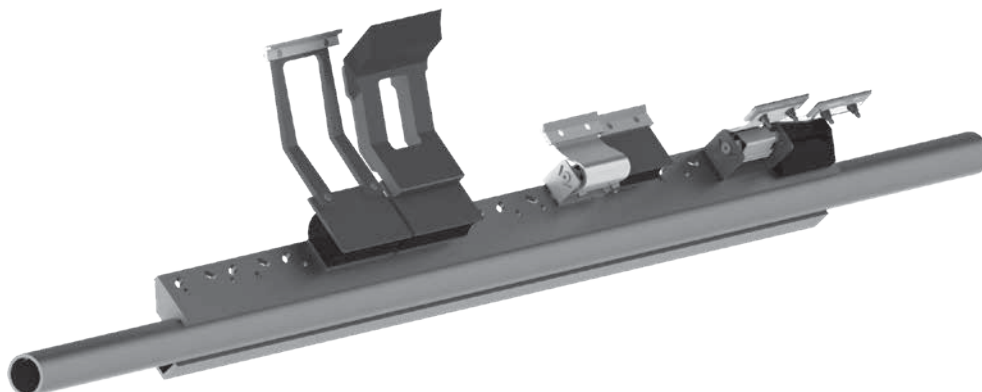



Universal Lightweight Pole

BELT WIDTH mm	ITEM CODE	ORDERING NUMBER	WT. KG
450	66122	ULP450	5.8
600	66123	ULP600	6.6
750	66124	ULP750	7.5
900	66125	ULP900	8.5
1050	66126	ULP1050	12.2
1200	66127	ULP1200	13.6
1350	66128	ULP1350	15.3
1500	66129	ULP1500	16.6
1650	66130	ULP1650	18.0
1800	67057	ULP1800	19.4
2000	67084	ULP2000	21.6
2200	67085	ULP2200	22.9
2400	67058	ULP2400	24.6
2600	67086	ULP2600	26.6
2800	67087	ULP2800	28.4
3000	67088	ULP3000	30.1

Product Notes:

- **Safety Driven Engineering.** The lightest cleaner pole on the market, engineered with safe lifting in mind.
- **Versatile.** Compatible with Flexco H-Type®, FMS, MHS & P-Type® Cleaners.
- **Made for Australian Mining Conditions.** Although lightweight, the universal pole has been tested to withstand the harshest mining conditions in Australia.

 **Stock items** (non-shaded) refer to (*) for specific lead time, if not specified, standard lead time applies.

 **Non-stock items** (shaded) please contact Flexco for dispatch options and lead times.

Product Ordering Information

Inspection Doors

Flexco can create inspection doors and cleaner mount inspection doors to suit your system. Please contact customer service for more details.

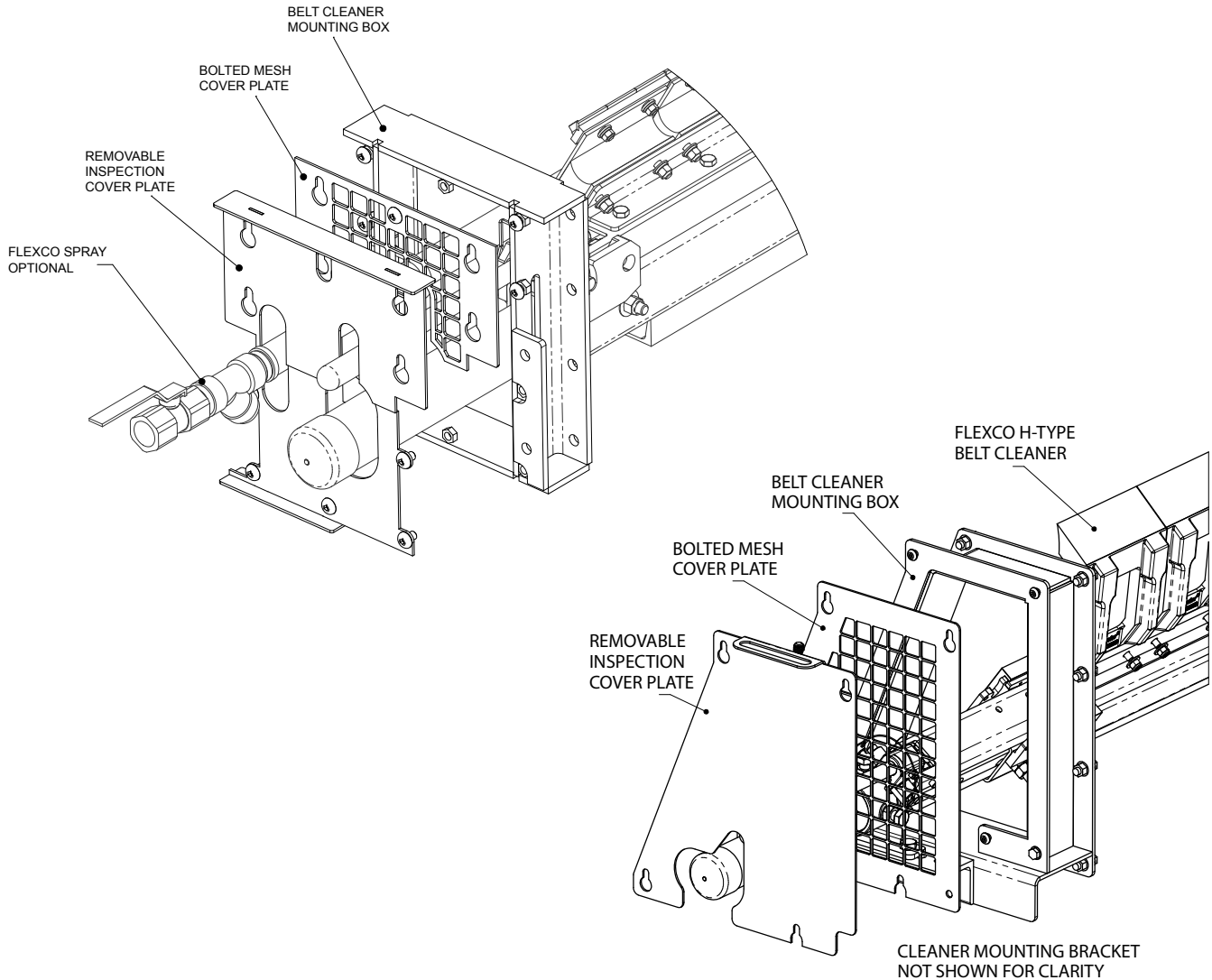

Product Notes:

- Please contact Flexco for pricing and lead times.
- Inspection doors are available in a range of sizes, please contact your Flexco representative or customer service for more information.
- Inspection doors can also be designed to your specifications.
- Constructed from heavy-duty grade 316 Stainless Steel.
- The solid outer door can be safely opened by hand without the need for any tools during normal operation of the equipment.
- The inner door features 3mm mesh at 50mm spacing and requires tools to remove ensuring workers remain safe behind the mesh.
- Cleaner tensions sit outside the mesh, allowing for staff to safely and effectively tension cleaners.

Stock items (non-shaded) refer to (*) for specific lead time, if not specified, standard lead time applies.

Non-stock items (shaded) please contact Flexco for dispatch options and lead times.

SAMPLE SPECIFICATIONS AND GUIDELINES

Inspection Door 300 mm x 300 mm

Chute Opening:	300 mm x 300 mm
Outer Door:	Solid c/w Lockable Handle
Inner Mesh Door:	3 mm mesh @ 50 mm spacing
Material:	Grade 316 Stainless Steel
Overall Weight:	8 kg

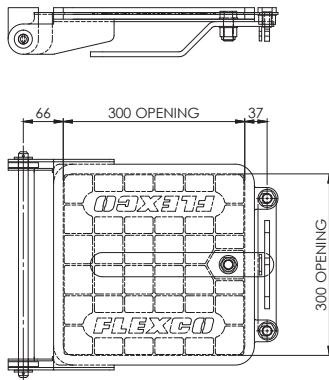

Inspection Door 400 mm x 400 mm

Chute Opening:	400 mm x 400 mm
Outer Door:	Solid c/w Lockable Handle
Inner Mesh Door:	3 mm mesh @ 50 mm spacing
Material:	Grade 316 Stainless Steel
Overall Weight:	13 kg

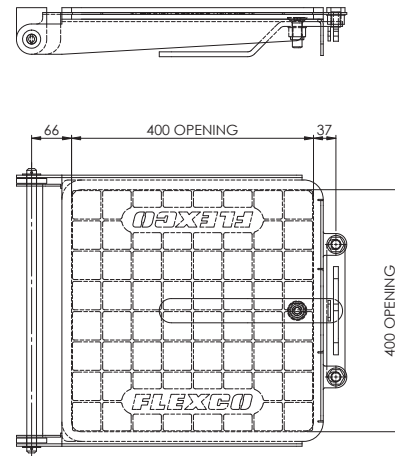

Inspection Door 500 mm x 500 mm

Chute Opening:	500 mm x 500 mm
Outer Door:	Solid c/w Lockable Handle
Inner Mesh Door:	3 mm mesh @ 50 mm spacing
Material:	Grade 316 Stainless Steel
Overall Weight:	18 kg

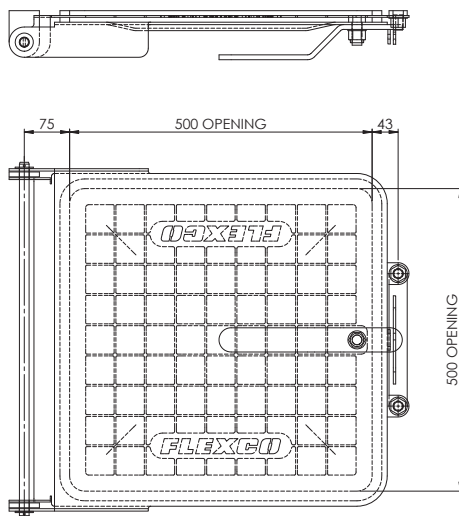

Inspection Door 600 mm x 600 mm

Chute Opening:	600 mm x 600 mm
Outer Door:	Solid c/w Lockable Handle
Inner Mesh Door:	3 mm mesh @ 50 mm spacing
Material:	Grade 316 Stainless Steel
Overall Weight:	32 kg

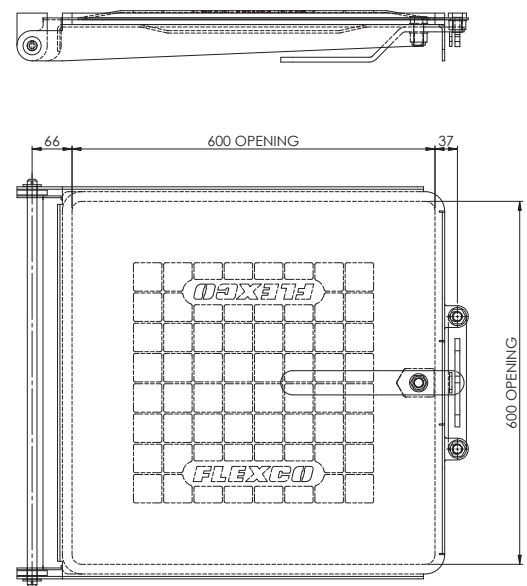

Product Ordering Information

Water Spray Pole Systems Belt Cleaner Accessories

Stand-Alone Spraybar Assemblies 38 mm dia.

BELT WIDTH mm	ORDERING NUMBER	ITEM CODE	WT. KG.
600	SB600A	A0887	4.0
750	SB750A	A0407	5.0
900	SB900A	A0912	5.5
1050	SB1050A	A0435	6.0
1200	SB1200A	A0316	7.0
1400	SB1400A	A1620	8.0
1500	SB1500A	A1838	9.0
1800	SB1800A	A1357	10.0

Spray Assembly includes spraybar, brass plug, y strainer, nozzles, and brackets to mount independently to structure.



Secondary Spraybar Assemblies

BELT WIDTH mm	ORDERING NUMBER	ITEM CODE	WT. KG.
600	SB600-SEC	61063	4.0
750	SB750-SEC	61064	5.0
900	SB900-SEC	61065	5.5
1050	SB1050-SEC	61066	6.0
1200	SB1200-SEC	61067	7.0
1400	SB1400-SEC	61068	8.0
1500	SB1500-SEC	61069	9.0
1800	SB1800-SEC	61070	10.0

Secondary Cleaner Spraybar Assemblies are designed to be clamped to secondary cleaners. Each assembly includes spraybar, nozzles, brass plug, y strainer, and clamping brackets to mount to secondary cleaner.

Lead time: 3 weeks

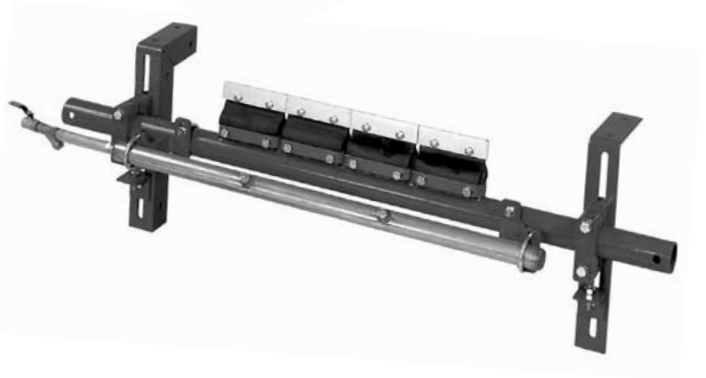

Water Control Manifold

ORDERING NUMBER	ITEM CODE	WT. KG.
WCB	A0012	10.0

Water Control Manifolds come complete with the following:

- 13 mm BSP connections
- Solenoid valve (24V DC Standard)
- Pressure regulator
- Filter strainer
- Lockable ball valves
- Manual bypass line
- Stainless steel backing plate



Spray Nozzles Per Cleaner Size

mm	450	600	750	900	1050	1200	1350	1500	1800	2100	2400	3000
Spray Nozzles	1	2	2	3	3	4	4	5	6	7	8	10

 Stock items (non-shaded) refer to (*) for specific lead time, if not specified, standard lead time applies.

 Non-stock items (shaded) please contact Flexco for dispatch options and lead times.

Product Ordering Information

Water Spray Pole Systems Belt Cleaner Accessories

PS Spraywash with V-Tips

BELT WIDTH mm	ORDERING NUMBER	ITEM CODE	WT. KG.
600	PS600	73014	27.0
750	PS750	73541	31.0
900	PS900	73542	33.0
1050	PS1050	73543	37.0
1200	PS1200	73544	40.0
1400	PS1400	73546	42.0
1500	PS1500	73545	47.0
1800	PS1800	73537	62.0
2000	PS2000	73539	68.0

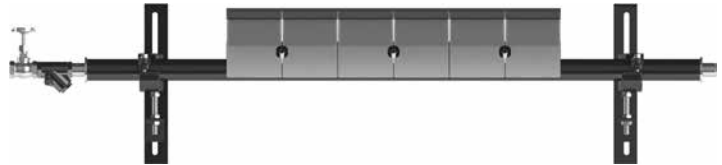

All Stainless Steel construction. Spraywash cleaners supplied standard with nozzles, deflector shields, Brass plug, and brass Y strainer.
Lead time: 3 weeks

Replacement Tips and Nozzles

BELT WIDTH mm	600	750	900	1050	1200	1400	1500	1800	2000
Tips/Cushions Required	4	5	6	7	8	9	10	12	13
Nozzles Required	2	3	3	3	4	5	5	6	7

Replacement Parts

REF	DESCRIPTION	POLE DIAMETER	BELT WIDTH	POLE LENGTH	ORDERING NUMBER	ITEM CODE	WT. KG.
1	PS Spray Poles	60	600	1350	PS600PL*	73582	15.0
			750	1500	PS750PL*	73583	16.0
			900	1650	PS900PL*	73584	19.0
			1050	1800	PS1050PL*	73585	22.0
		73	1200	1950	PS1200PL*	73586	26.0
			1400	2200	PS1400PL*	73587	29.0
			1500	2350	PS1500PL*	73588	33.0
			1800	2650	PS1800PL*	74049	36.0
	2000	2850	PS2000 PL*	74050	40.0		
2	P-V Tip				PVT6-S/S	75420	0.4
3	PH High Speed Cushion - Stainless				PHSC-S/S	73433	1.0
4	Spray Nozzle				PSN11010	74053	1.0
5	Valve Assembly				PSVA	73434	1.0
6	Water Control Board - 24 Volt DC				WCB	A0012	10.0
-	Stainless Shield - Notch				PSSS-N	73221	0.5
-	Stainless Shield - Hole				PSSS-H	73222	0.5

Hardware included
*Lead time: 3 weeks

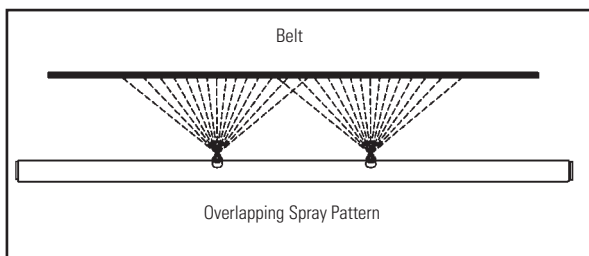

Specifications

- Stainless steel pole with stainless steel clamping brackets.
- Spray nozzles are spaced on 300 mm centers.
- Spray nozzles delivers 5 litres per minute, per nozzle at 500 kPa.
- Maximum inlet pressure is 1000 kPa.
- Typical pressure setting is 200-600 kPa.

 Stock items (non-shaded) refer to (*) for specific lead time, if not specified, standard lead time applies.

 Non-stock items (shaded) please contact Flexco for dispatch options and lead times.

Product Ordering Information

Mandrel Safety Removal Systems Belt Cleaner Accessories

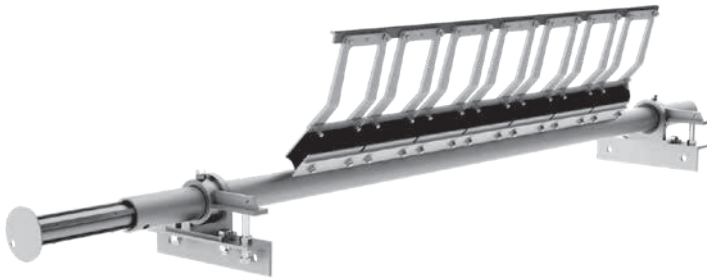

H-Type® primary cleaner shown (cleaner not included)

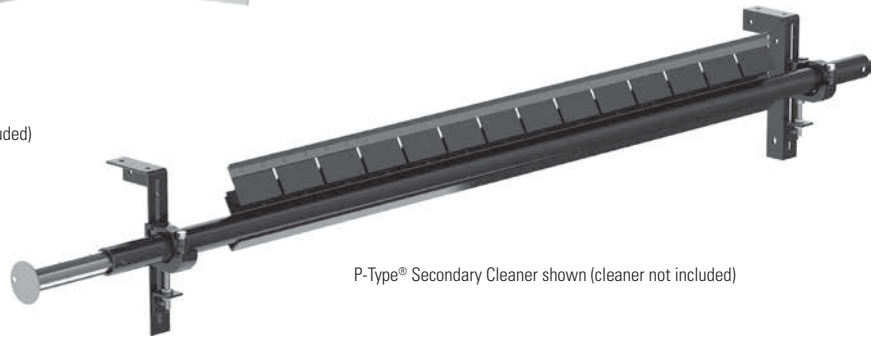

P-Type® Secondary Cleaner shown (cleaner not included)

Mandrel Poles

BELT WIDTH mm	CLEANER POLE DIA.	GALVANISED MANDREL POLE		
		ORDERING NUMBER	ITEM CODE	WT. KG.
450	60	MR-450PG	A2836	5.0
600	60	MR-600PG	A2837	6.0
750	60	MR-750PG	A2838	6.5
900	60	MR-900PG	A2839	7.5
1050	60	MR-1050PG	A2840	8.5
1200	60	MR-1200PG	A2841	9.0
1500	73	MR-1500PG	A2829	10.0
1600	73	MR-1600PG	A2830	11.0
1800	73	MR-1800PG	A2831	12.0
2100	73	MR-2100PG	A2832	13.5
2400	73	MR-2400PG	A2833	15.0
2600	73	MR-2600PG	A2834	16.5
3000	73	MR-3000PG	A2835	19.0

A Mandrel Kit requires 1 pole, 1 left hand block and 1 right hand block.

Lead time: 3 weeks

Cradle H Bearings Primary Cleaners

POWDER COATED			
ORDERING NUMBER	ITEM CODE	POLE DIA.	WT. KG.
PMR-CHB-L73	61075	73	1.5
PMR-CHB-R73	61076	73	1.5
PMR-CHB-L60	61073	60	1.3
PMR-CHB-R60	61074	60	1.3

Cradle Clamp Blocks Secondary Cleaners

POWDER COATED		
ORDERING NUMBER	ITEM CODE	POLE DIA.
SMR-CCB-L73	A2842	73
SMR-CCB-R73	A2843	73
SMR-CCB-L60	A2844	60
SMR-CCB-R60	A2845	60

Stock items (non-shaded) refer to (*) for specific lead time, if not specified, standard lead time applies.

Non-stock items (shaded) please contact Flexco for dispatch options and lead times.

Product Ordering Information

Live-Shaft Hold-Down Roll Belt Cleaner Accessories

Live-Shaft Hold-Down Roll

BELT WIDTH		ROLL DIAMETER		ORDERING NUMBER	ITEM CODE	WT. KG.
mm	in.	mm	in.			
600	24	114	4 1/2	HDR24	79010	72.3
750	30	114	4 1/2	HDR30	79011	76.8
900	36	114	4 1/2	HDR36	79012	81.8
1050	42	114	4 1/2	HDR42	79013	86.4
1200	48	114	4 1/2	HDR48	79014	113.2
1350	54	114	4 1/2	HDR54	79015	115.9
1500	60	114	4 1/2	HDR60	79016	120.5
1800	72	127	5	HDRS72*	79017	256.8
2100	84	127	5	HDRS84*	79018	279.5

*1800mm and 2100mm (72" and 84") feature solid roll

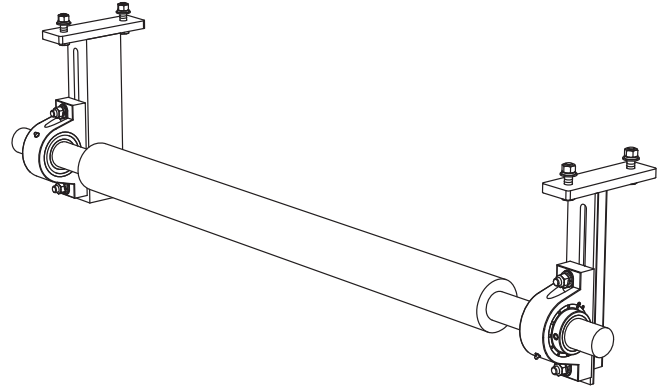

Replacement Roll

BELT WIDTH		ROLL DIAMETER		ORDERING NUMBER	ITEM CODE	WT. KG.
mm	in.	mm	in.			
600	24	114	4 1/2	HDRR24	79019	51.8
750	30	114	4 1/2	HDRR30	79020	56.4
900	36	114	4 1/2	HDRR36	79021	61.4
1050	42	114	4 1/2	HDRR42	79022	65.9
1200	48	114	4 1/2	HDRR48	79023	92.7
1350	54	114	4 1/2	HDRR54	79024	95.5
1500	60	114	4 1/2	HDRR60	79025	100.0
1800	72	127	5	HDRRS72*	79026	236.4
2100	84	127	5	HDRRS84*	79027	259.1

*1800mm and 2100mm (72" and 84") feature solid roll

Roller Bracket Kit*

DESCRIPTION	ORDERING NUMBER	ITEM CODE	WT. KG.
Hold Down Roll Bracket Kit - 600mm to 1500mm	HDRBK	79009	20.5
HD Hold Down Roll Bracket Kit - 1800mm to 2100mm	HDRBK-HD	79072	20.5

*Includes Left and Right Bracket

Add-On Grease Hose Extension Kit

DESCRIPTION	ORDERING NUMBER	ITEM CODE	WT. KG.
Grease Hose Extension Kit (incl. 2 ea. 400mm (16") hose w/fittings and tie-downs)	HDRGEK	79236	0.5

Specifications:

- Overall Roll Length..... Belt Width 150mm (+6")
- Overall Shaft Length Belt Width 750mm (+30")
- Shaft Diameter..... 600-1050mm (24" - 42") - 49.2mm (1-15/16") diameter
1200-1500mm (48" - 60") - 61.9mm (2-7/16") diameter
1800-2100mm (72" - 84") - 74.6 (2-15/16") diameter
- Shaft Construction 600-1500mm (24" - 60") - 1045 CD
1800-2100mm (72" - 84") - turned from solid 4140 round stock

Product Notes:

- For use in applications with belt cup or belt flap.
- By preventing these issues secondary cleaner performance and blade/tip life is enhanced.

Stock items (non-shaded) refer to (*) for specific lead time, if not specified, standard lead time applies.

Non-stock items (shaded) please contact Flexco for dispatch options and lead times.

Product Ordering Information

Standard Pulley Lifters

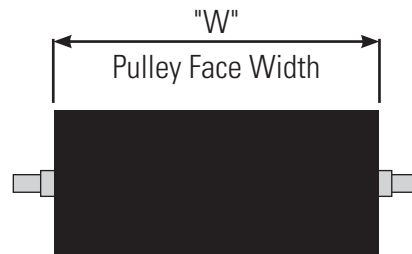
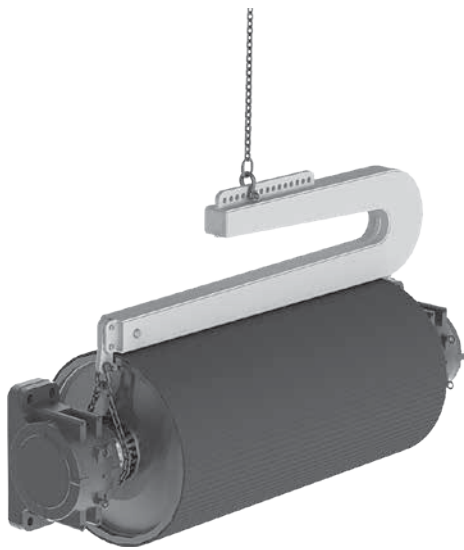



Pulley Face Widths

	800-1200	1200-1600	1600-2000	2000-2400
3 TONNE CAPACITY	1-PL-800-1200-3	1-PL-1200-1600-3	1-PL-1600-2000-3	1-PL-2000-2400-3
6 TONNE CAPACITY	1-PL-800-1200-6	1-PL-1200-1600-6	1-PL-1600-2000-6	1-PL-2000-2400-6
12 TONNE CAPACITY	1-PL-800-1200-12	1-PL-1200-1600-12	1-PL-1600-2000-12	1-PL-2000-2400-12

Product Notes:

- Please contact Flexco for pricing and lead times.
- Made from high strength steel to Australian Standards.
- Each pulley lifter proof load tested after manufacture and supplied with certificate of compliance and a safety operations and maintenance manual.
- Supplied in safety yellow as standard (other colours available on request).

 **Stock items** (non-shaded) refer to (*) for specific lead time, if not specified, standard lead time applies.

 **Non-stock items** (shaded) please contact Flexco for dispatch options and lead times.

Product Ordering Information

Belt Cleaner Accessories

Stabilising Roller Bracket Kit*

Provides universal brackets to mount the user's return roller as a hold-down (stabilising) roller on top of the return side belt. Holds the belt flat so the belt cleaner can maximize its cleaning performance.

DESCRIPTION	ORDERING NUMBER	ITEM CODE	WT. KG.
Stabilising Roller Bracket Kit	SRBK	74941	15.5

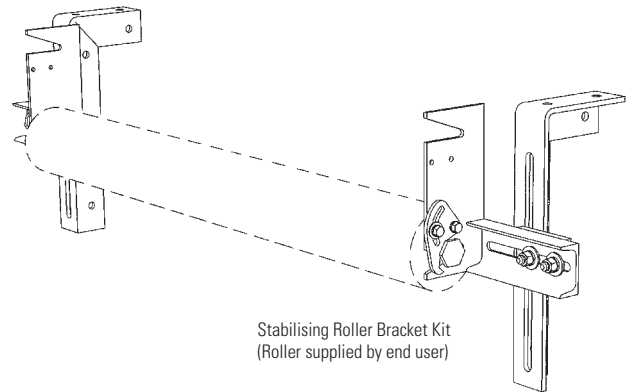

Hold Down Roll Assembly Kits

DESCRIPTION	ORDERING NUMBER	ITEM CODE	WT. KG.
Hold Down Roll Assembly Kit S/S 17mm*	HDRP17	63679	1.9
Hold Down Roll Assembly Kit S/S 22mm*	HDRP22	63678	1.9

Kit includes:

- Stainless Steel Hold Down Roller Pole Kit to suit 17mm or 22mm A/F Roller
- S/S Mounting Kit

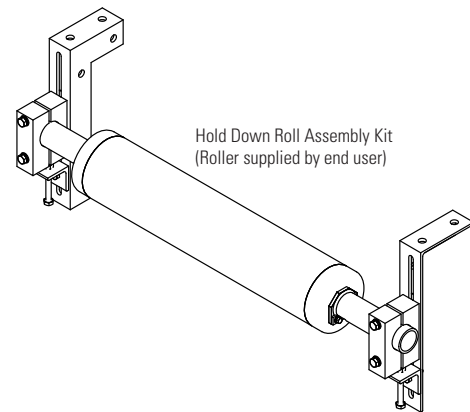

Tip Tension Scale

For easy checking of blade tension on all H-Type® Primary Cleaners.

DESCRIPTION	ORDERING NUMBER	ITEM CODE	WT. KG.
H Tip Tension Scale	HTTS	74141	0.1

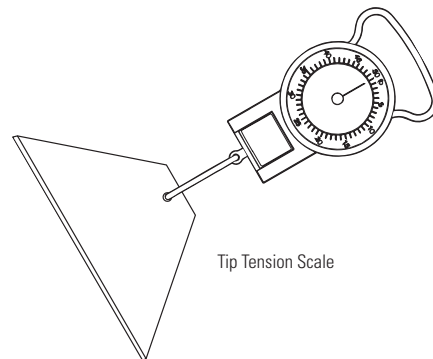

Spring Tension Chart (recommended tensions)

CLEANER	HXF	H V-TIP	H PROTECTED V-TIP	HI-TEMP V-TIP
Kg	12.7	8.2	8.2	8.2

For installation and for retensioning blades during maintenance.

Belt Cleaner Handy Wrench

A ratcheting wrench with 2 common socket sizes (11/16" & 3/4", 17mm & 19mm) for belt cleaner installation and maintenance.

DESCRIPTION	ORDERING NUMBER	ITEM CODE	WT. KG.
Belt Cleaner Handy Wrench	HW-BC	74100	0.6

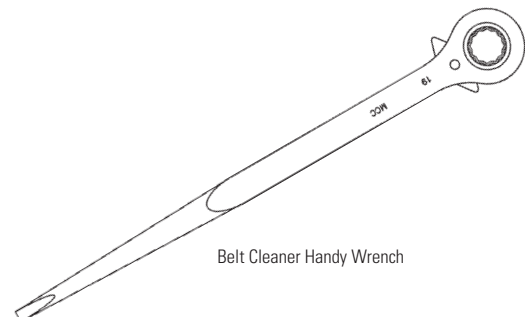

Stock items (non-shaded) refer to (*) for specific lead time, if not specified, standard lead time applies.

Non-stock items (shaded) please contact Flexco for dispatch options and lead times.

Product Ordering Information

Optional Mounting Kits

OPTIONAL MOUNTING KITS FOR BELT CLEANERS

Versatile, adjustable brackets and plates that can be mounted on the conveyor structure so Primary Cleaners and secondary cleaners can be easily and quickly bolted into place.

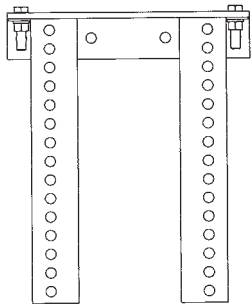

76071
Standard Mounting Bracket Kit
• For most secondary cleaner installs.

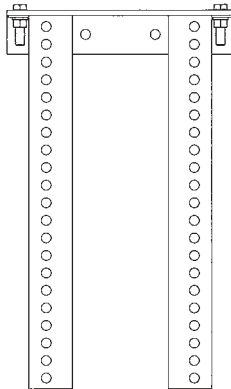

76072
Long Mounting Bracket Kit
• For installations that require extra length legs.

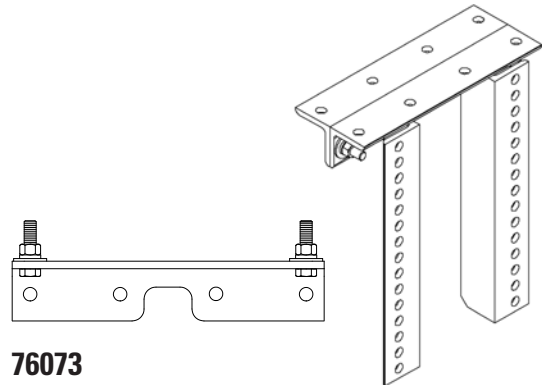

76073
Optional Top Angle Kit
• Used with both standard and long mounting bracket kits for additional mounting options.

Optional Mounting Kits

(includes 2 brackets/bars)

DESCRIPTION	ORDERING NUMBER	ITEM CODE	WT. KG.
Standard Mounting Bracket Kit*	SSTSMB	76071	15.6
Long Mounting Bracket Kit*	SSTLMB	76072	19.7

Hardware Included

Specifications

- Standard brackets are 330 mm W x 394 mm L.
- Long brackets are 330 mm W x 546 mm L.
- Mounting bars are 38 mm W x 406 mm L with (4) 16-279 mm tapped holes.
- Mounting plates are 406 mm W x 813 mm L with (4) 16 mm holes.

Pole Extender Kit

(includes 2 pole extenders)

DESCRIPTION	ORDERING NUMBER	ITEM CODE	WT. KG.
Pole Extender Kit	MAPEK	76024	9.9

Provides 750 mm of extended pole length.

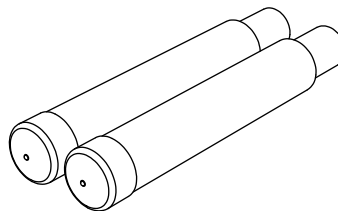

Stock items (non-shaded) refer to (*) for specific lead time, if not specified, standard lead time applies.

Non-stock items (shaded) please contact Flexco for dispatch options and lead times.

Specifications & Guidelines

Flexco® Slider/Impact Beds

Easy Solution for Load Zone Problems

- Complete load zone offering with slider beds through impact beds for up to 100 kg-m of force.
- No specifying trough angle; each bed is adjustable for 20°, 35° and 45° trough settings (ships at 35° setting)
- Low-profile installation. Because Flexco® beds feature trough wings that are adjustable, they lay flat during installation, providing more clearance.
- Full UHMW slider bars included on outside bar to provide proper sealing and long life.
- Unique Impact Bar Supports protect the impact bars from damage, extending service life. An Anti-Migratory Tab on each support secures the bar and prevents it from sliding in the direction of belt travel.
- All beds are manufactured for mounting holes belt width + 250mm (600-1200mm beds), + 300mm (1350-1500mm beds), and + 400mm (1800mm beds). For wider structure, contact Customer Service for special quote.

How to spec the correct slider/impact bed for your conveyor transfer point

Roller Size
 127mm 152mm 178mm
Belt Width: _____
Bed Length: 1200mm 1500mm

Impact Energy Calculation Chart

Impact Energy

Lump Weight (**w**) _____
 Drop Height (**h**) **x** _____

Total = **kg-m** See Below

0 kg-m — **EZSB-C**
 0 - 25kg-m — **EZSB-I or EZIB-L**
 25-100 kg-m — **EZIB-M**

Product Ordering Information

EZSB-C
Flexco® Slider Beds
CoreTech™ Rolls

Contact Flexco for information and pricing on shorter lead times and non-standard impact beds. Please note that freight for all impact beds are ex-works



Flexco Slider Bed with CoreTech™ Rolls 1200mm

(for non-impact areas)

BELT WIDTH mm	ORDERING NUMBER	ITEM CODE	WT. KG.
600	EZSB600-1200C	82185	110.7
750	EZSB750-1200C	82186	119.4
900	EZSB900-1200C	82187	131.1
1050	EZSB1050-1200C	82188	162.7
1200	EZSB1200-1200C	82189	175.0
1350	EZSB1350-1200C	82190	206.4
1500	EZSB1500-1200C	82191	217.1
1800	EZSB1800-1200C	82192	232.7

Lead time: 4 weeks

Flexco Slider Bed with CoreTech™ Rolls 1500mm

(for non-impact areas)

BELT WIDTH mm	ORDERING NUMBER	ITEM CODE	WT. KG.
600	EZSB600-1500C	82193	118.4
750	EZSB750-1500C	82194	126.9
900	EZSB900-1500C	82195	138.6
1050	EZSB1050-1500C	82196	173.7
1200	EZSB1200-1500C	82197	186.2
1350	EZSB1350-1500C	82198	221.4
1500	EZSB1500-1500C	82199	232.1
1800	EZSB1800-1500C	82200	247.6

Lead time: 4 weeks

Adjustable Idler Set with CoreTech™ Rolls

(for placement in between 3 or more beds)



BELT WIDTH mm	ORDERING NUMBER	ITEM CODE	WT. KG.
600	EZAI-600	82410	36.2
750	EZAI-750	82411	40.8
900	EZAI-900	82412	45.7
1050	EZAI-1050	82413	49.9
1200	EZAI-1200	82414	55.9
1350	EZAI-1350	82415	60.1
1500	EZAI-1500	82416	64.1
1800	EZAI-1800	82417	74.2

Lead time: 4 weeks

Product Notes:

- No need to specify troughing angle—designed to adjust to 20°, 35°, 45°.
- Designed for containment in the load zone, but not intended for impact zones.
- Slider bars are solid 25mm UHMW providing longer wear life and consistent load zone sealing.
- Product ships with two idlers. Additional idlers can be added by purchasing a EZRMK and the appropriate corresponding idler.

Replacement Parts List

EZSB-C
Flexco® Slider Beds
CoreTech™ Rolls

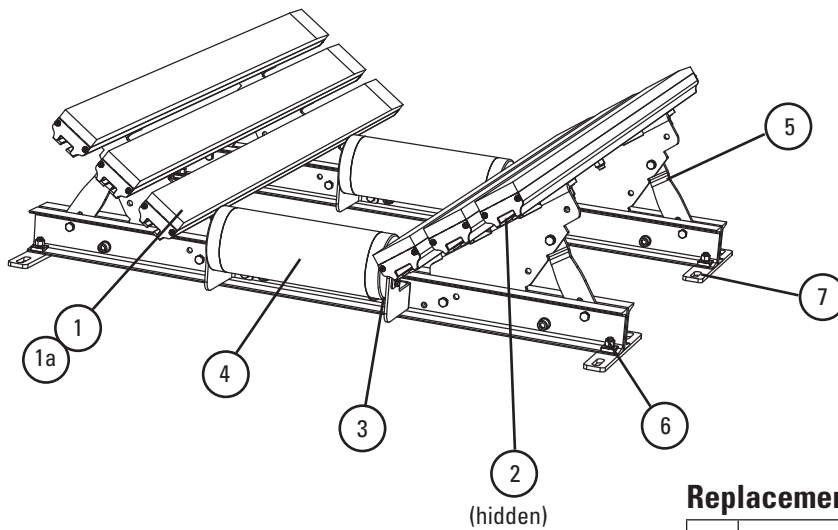

Replacement Parts

REF	DESCRIPTION	ORDERING NUMBER	ITEM CODE	WT. KG.
1	Slider Bar, 1200mm	SB4	78789	9.1
1a	Slider Bar, 1500mm	SB5	78790	10.9
2	Bar Bolt Kit (incl. 1 ea. 16mm carriage bolt, square washer, flat washer, lock washer, Nylock nut)	RIBBK	81250	0.2
3	Slider Roll Mount Kit*	EZRMKM	82344	2.3
4	CoreTech™ Roll 600mm	N6D3T-24-9-A45	26107	4.1
	CoreTech Roll 750mm	N6D3T-30-11-A45	26108	4.8
	CoreTech Roll 900mm	N6D3T-36-13-A45	26109	5.6
	CoreTech Roll 1050mm	N6D3T-42-15-A45	26110	6.3
	CoreTech Roll 1200mm	N6D3T-48-17-A45	26111	7.3
	CoreTech Roll 1350mm	N6D3T-54-19-A45	26112	7.7
	CoreTech Roll 1500mm	N6D3T-60-21-A45	26113	8.2
	CoreTech Roll 1800mm	N6D3T-72-25-A45	26114	9.8
5	Wing Plate Kit 600mm*	EZWPK-600	82345	7.7
	Wing Plate Kit 750mm*	EZWPK-750	82346	7.9
	Wing Plate Kit 900mm*	EZWPK-900	82347	9.6
	Wing Plate Kit 1050mm*	EZWPK-1050	82348	11.9
	Wing Plate Kit 1200mm*	EZWPK-1200	82349	13.7
	Wing Plate Kit 1350mm*	EZWPK-1350	82350	16.1
	Wing Plate Kit 1500mm*	EZWPK-1500	82351	17.7
	Wing Plate Kit 1800mm*	EZWPK-1800	82352	21.2
6	Cross Stringer Kit 600mm*	EZCSK-600	82353	22.3
	Cross Stringer Kit 750mm*	EZCSK-750	82354	25.6
	Cross Stringer Kit 900mm*	EZCSK-900	82355	28.9
	Cross Stringer Kit 1050mm*	EZCSK-1050	82356	32.1
	Cross Stringer Kit 1200mm*	EZCSK-1200	82357	35.6
	Cross Stringer Kit 1350mm*	EZCSK-1350	82358	38.9
	Cross Stringer Kit 1500mm*	EZCSK-1500	82359	42.2
	Cross Stringer Kit 1800mm*	EZCSK-1800	82360	45.0
7	Shim Kit Light Duty (incl. 4 shims)	SHIM-LDKIT	82393	6.2

*Hardware Included. Lead time: 4 weeks.

Replacement Quantities for EZSB-C

mm	600	750	900	1050	1200	1350	1500	1800
ROLLS REQUIRED	2	2	2	2	2	2	2	2
BARS REQUIRED	SLIDER	4	4	4	6	6	8	8
BAR BOLT KITS REQUIRED	8	8	8	12	12	16	16	16

Product Ordering Information

EZSB-I Flexco® Slider Beds CoreTech™ Impact Rolls

Contact Flexco for information and pricing on shorter lead times and non-standard impact beds.
Please note that freight for all impact beds are ex-works



Flexco Slider Bed with CoreTech™ Impact Rolls 1200mm

(for impact zones with less than 25 Kg-m energy)

BELT WIDTH mm	ORDERING NUMBER	ITEM CODE	WT. KG.
600	EZSB600-1200I	82201	125.6
750	EZSB750-1200I	82202	136.1
900	EZSB900-1200I	82203	149.7
1050	EZSB1050-1200I	82204	184.7
1200	EZSB1200-1200I	82205	198.2
1350	EZSB1350-1200I	82206	233.1
1500	EZSB1500-1200I	82207	246.3
1800	EZSB1800-1200I	82208	265.8

Lead time: 4 weeks

Flexco Slider Bed with CoreTech™ Impact Rolls 1500mm

(for impact zones with less than 25 Kg-m energy)

BELT WIDTH mm	ORDERING NUMBER	ITEM CODE	WT. KG.
600	EZSB600-1500I	82209	133.4
750	EZSB750-1500I	82210	143.8
900	EZSB900-1500I	82211	157.5
1050	EZSB1050-1500I	82212	196.4
1200	EZSB1200-1500I	82213	210.0
1350	EZSB1350-1500I	82214	248.9
1500	EZSB1500-1500I	82215	262.1
1800	EZSB1800-1500I	82216	281.3

Product Notes:

- No need to specify troughing angle—designed to adjust to 20°, 35°, 45°.
- Outermost trough bar features 25mm solid UHMW slider bar to provide longer wear life and consistent load zone sealing where impact is not present.

Replacement Parts List

EZSB-I
Flexco® Slider Beds
 CoreTech™ Impact Rolls

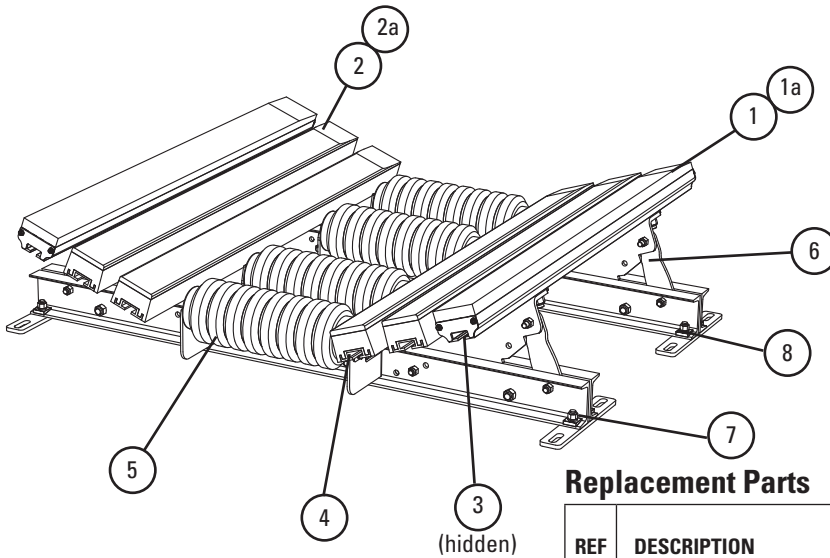

Replacement Parts

REF	DESCRIPTION	ORDERING NUMBER	ITEM CODE	WT. KG.
1	Slider Bar, 1200mm	SB4	78789	9.1
1a	Slider Bar, 1500mm	SB5	78790	10.9
2	Impact Bar, 1200mm	IB4	76926	7.7
2a	Impact Bar, 1500mm	IB5	76927	9.5
3	Bar Bolt Kit (incl. 1 ea. 16mm carriage bolt, square washer, flat washer, lock washer, Nylock nut)	RIBBK	81250	0.2
4	Slider Roll Mount Kit*	EZRMMK	82344	2.3
5	Impact CoreTech™ Roll 600mm	NI6D3T-24-9-A45	26184	4.6
	Impact CoreTech Roll 750mm	NI6D3T-30-11-A45	26185	5.4
	Impact CoreTech Roll 900mm	NI6D3T-36-13-A45	26186	6.3
	Impact CoreTech Roll 1050mm	NI6D3T-42-15-A45	26187	7.3
	Impact CoreTech Roll 1200mm	NI6D3T-48-17-A45	26188	8.1
	Impact CoreTech Roll 1350mm	NI6D3T-54-19-A45	26189	9.0
	Impact CoreTech Roll 1500mm	NI6D3T-60-21-A45	26190	9.8
	Impact CoreTech Roll 1800mm	NI6D3T-72-25-A45	26191	11.6
6	Wing Plate Kit 600mm*	EZWPK-600	82345	7.7
	Wing Plate Kit 750mm*	EZWPK-750	82346	7.9
	Wing Plate Kit 900mm*	EZWPK-900	82347	9.6
	Wing Plate Kit 1050mm*	EZWPK-1050	82348	11.9
	Wing Plate Kit 1200mm*	EZWPK-1200	82349	13.7
	Wing Plate Kit 1350mm*	EZWPK-1350	82350	16.1
	Wing Plate Kit 1500mm*	EZWPK-1500	82351	17.7
	Wing Plate Kit 1800mm*	EZWPK-1800	82352	21.2
7	Cross Stringer Kit 600mm*	EZCSK-600	82353	22.3
	Cross Stringer Kit 750mm*	EZCSK-750	82354	25.6
	Cross Stringer Kit 900mm*	EZCSK-900	82355	28.9
	Cross Stringer Kit 1050mm*	EZCSK-1050	82356	32.1
	Cross Stringer Kit 1200mm*	EZCSK-1200	82357	35.6
	Cross Stringer Kit 1350mm*	EZCSK-1350	82358	38.9
	Cross Stringer Kit 1500mm*	EZCSK-1500	82359	42.2
	Cross Stringer Kit 1800mm*	EZCSK-1800	82360	45.0
8	Shim Kit Light Duty (incl. 4 shims)	SHIM-LDKIT	82393	6.2

*Hardware Included. Lead time: 4 weeks.

Replacement Quantities for EZSB-I

mm	600	750	900	1050	1200	1350	1500	1800
ROLLS REQUIRED	4	4	4	4	4	4	4	4
BARS REQUIRED	SLIDER	2	2	2	2	2	2	2
	IMPACT	2	2	2	4	4	6	6
BAR BOLT KITS REQUIRED	8	8	8	12	12	16	16	16

Product Ordering Information

EZIB-L **Flexco® Impact Beds** *All Bars - Light Duty*

Contact Flexco for information and pricing on shorter lead times and non-standard impact beds. Please note that freight for all impact beds are ex-works



Flexco® Impact Bed Light Duty 1200mm

(for impact zones with less than 25 Kg-m energy)

BELT WIDTH mm	ORDERING NUMBER	ITEM CODE	WT. KG.
600	EZIB600-1200L	82217	138.0
750	EZIB750-1200L	82218	145.6
900	EZIB900-1200L	82219	174.5
1050	EZIB1050-1200L	82220	206.1
1200	EZIB1200-1200L	82221	235.1
1350	EZIB1350-1200L	82222	267.2
1500	EZIB1500-1200L	82223	295.7
1800	EZIB1800-1200L	82224	327.3

Lead time: 4 weeks

Flexco Impact Bed Light Duty 1500mm

(for impact zones with less than 25 Kg-m energy)

BELT WIDTH mm	ORDERING NUMBER	ITEM CODE	WT. KG.
600	EZIB600-1500L	82225	153.7
750	EZIB750-1500L	82226	161.3
900	EZIB900-1500L	82227	194.2
1050	EZIB1050-1500L	82228	229.7
1200	EZIB1200-1500L	82229	262.8
1350	EZIB1350-1500L	82230	298.8
1500	EZIB1500-1500L	82231	331.1
1800	EZIB1800-1500L	82232	366.8

Lead time: 4 weeks

Product Notes:

- No need to specify troughing angle—designed to adjust to 20°, 35°, 45°.
- Outermost trough bar features 25mm solid UHMW slider bar to provide longer wear life and consistent load zone sealing where impact is not present.

Replacement Parts List

EZIB-L
Flexco® Impact Beds
All Bars - Light Duty

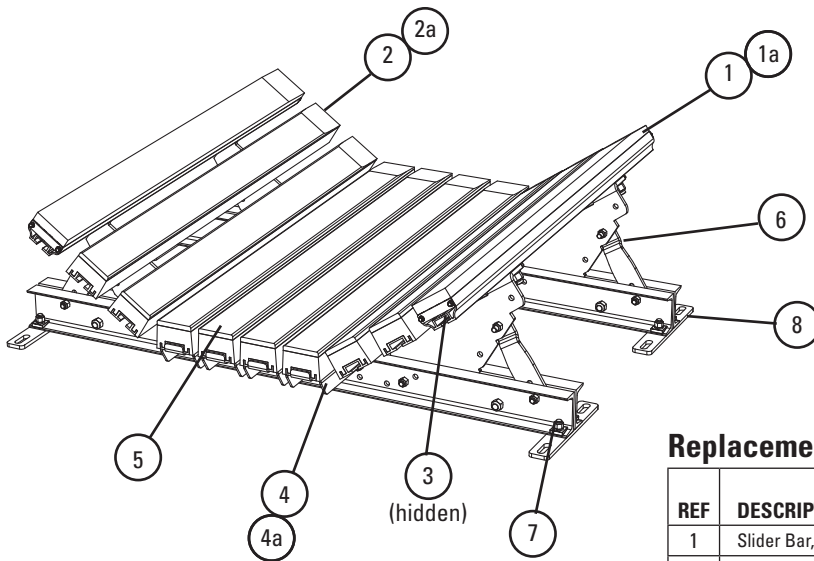

Replacement Parts

REF	DESCRIPTION	ORDERING NUMBER	ITEM CODE	WT. KG.
1	Slider Bar, 1200mm	SB4	78789	9.1
1a	Slider Bar, 1500mm	SB5	78790	10.9
2	Impact Bar, 1200mm	IB4	76926	7.7
2a	Impact Bar, 1500mm	IB5	76927	9.5
3	Bar Bolt Kit (incl. 1 ea. 16mm carriage bolt, square washer, flat washer, lock washer, Nylock nut)	RIBBK	81250	0.2
4	Impact Bar Support - 1.2M*	EZBS-1200	82361	7.3
4a	Impact Bar Support - 1.5M*	EZBS-1500	82362	9.3
5	Centre Bar Mount Kit 600mm*	EZBMK-600	82281	2.4
	Centre Bar Mount Kit 750mm*	EZBMK-750	82282	2.6
	Centre Bar Mount Kit 900mm*	EZBMK-900	82283	3.4
	Centre Bar Mount Kit 1050mm*	EZBMK-1050	82284	3.6
	Centre Bar Mount Kit 1200mm*	EZBMK-1200	82285	4.4
	Centre Bar Mount Kit 1350mm*	EZBMK-1350	82286	4.8
	Centre Bar Mount Kit 1500mm*	EZBMK-1500	82287	5.6
	Centre Bar Mount Kit 1800mm*	EZBMK-1800	82288	6.6
6	Wing Plate Kit 600mm*	EZWPK-600	82345	7.7
	Wing Plate Kit 750mm*	EZWPK-750	82346	7.9
	Wing Plate Kit 900mm*	EZWPK-900	82347	9.6
	Wing Plate Kit 1050mm*	EZWPK-1050	82348	11.9
	Wing Plate Kit 1200mm*	EZWPK-1200	82349	13.7
	Wing Plate Kit 1350mm*	EZWPK-1350	82350	16.1
	Wing Plate Kit 1500mm*	EZWPK-1500	82351	17.7
	Wing Plate Kit 1800mm*	EZWPK-1800	82352	21.2
7	Cross Stringer Kit 600mm*	EZCSK-600	82353	22.3
	Cross Stringer Kit 750mm*	EZCSK-750	82354	25.6
	Cross Stringer Kit 900mm*	EZCSK-900	82355	28.9
	Cross Stringer Kit 1050mm*	EZCSK-1050	82356	32.1
	Cross Stringer Kit 1200mm*	EZCSK-1200	82357	35.6
	Cross Stringer Kit 1350mm*	EZCSK-1350	82358	38.9
	Cross Stringer Kit 1500mm*	EZCSK-1500	82359	42.2
	Cross Stringer Kit 1800mm*	EZCSK-1800	82360	45.0
8	Shim Kit Light Duty (incl. 4 shims)	SHIM-LDKIT	82393	6.2

*Hardware Included. Lead time: 4 weeks.

Replacement Quantities for EZIB-L

mm		600	750	900	1050	1200	1350	1500	1800
BARS REQUIRED	SLIDER	2	2	2	2	2	2	2	2
	IMPACT	4	4	5	7	8	10	11	12
BAR BOLT KITS REQUIRED		14	14	17	21	24	28	31	34
BAR SUPPORTS REQUIRED		2	2	3	3	4	4	5	6

Product Ordering Information

EZIB-M **Flexco® Impact Beds** *All Bars - Medium Duty*

Contact Flexco for information and pricing on shorter lead times and non-standard impact beds.
Please note that freight for all impact beds are ex-works



Flexco® Impact Bed Medium Duty 1200mm

(for impact zones with 25-100 Kg-m energy)

BELT WIDTH mm	ORDERING NUMBER	ITEM CODE	WT. KG.
600	EZIB600-1200M	82233	185.7
750	EZIB750-1200M	82234	197.1
900	EZIB900-1200M	82235	214.7
1050	EZIB1050-1200M	82236	269.9
1200	EZIB1200-1200M	82237	305.2
1350	EZIB1350-1200M	82238	343.8
1500	EZIB1500-1200M	82239	361.1
1800	EZIB1800-1200M	82240	382.9

Lead time: 4 weeks

Flexco Impact Bed Medium Duty 1500mm

(for impact zones with 25-100 Kg-m energy)

BELT WIDTH mm	ORDERING NUMBER	ITEM CODE	WT. KG.
600	EZIB600-1500M	82241	205.3
750	EZIB750-1500M	82242	216.6
900	EZIB900-1500M	82243	234.3
1050	EZIB1050-1500M	82244	297.4
1200	EZIB1200-1500M	82245	336.7
1350	EZIB1350-1500M	82246	379.3
1500	EZIB1500-1500M	82247	396.6
1800	EZIB1800-1500M	82248	461.0

Lead time: 4 weeks

Product Notes:

- No need to specify troughing angle—designed to adjust to 20°, 35°, 45°.
- Outermost trough bar features 25mm solid UHMW slider bar to provide longer wear life and consistent load zone sealing where impact is not present.

Replacement Parts List

EZIB-M
Flexco® Impact Beds
 All Bars - Medium Duty

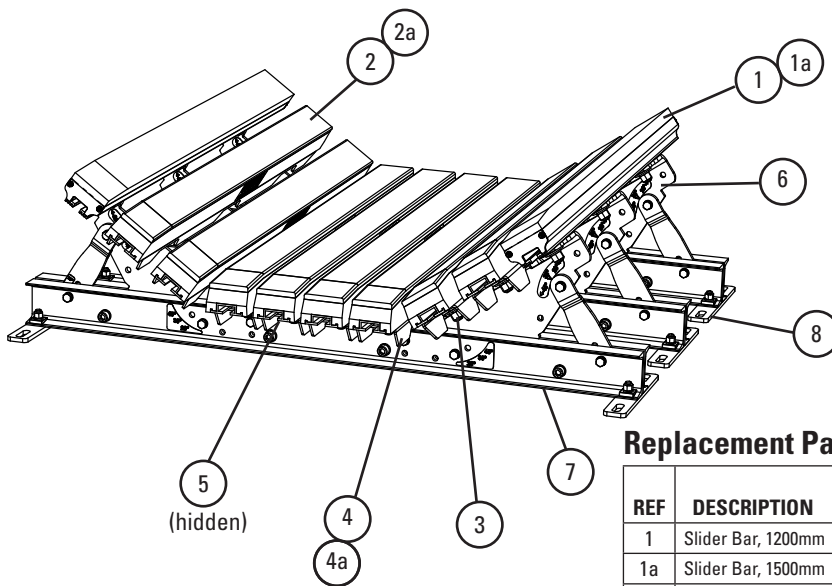

Replacement Parts

REF	DESCRIPTION	ORDERING NUMBER	ITEM CODE	WT. KG.
1	Slider Bar, 1200mm	SB4	78789	9.1
1a	Slider Bar, 1500mm	SB5	78790	10.9
2	Impact Bar, 1200mm	IB4	76926	7.7
2a	Impact Bar, 1500mm	IB5	76927	9.5
3	Bar Bolt Kit (incl. 1 ea. 16mm carriage bolt, square washer, flat washer, lock washer, Nylock nut)	RIBBK	81250	0.2
4	Impact Bar Support - 1200mm*	IBS-M1200	82397	7.7
4a	Impact Bar Support - 1500mm*	IBS-M1500	82398	9.6
5	Centre Bar Mount Kit 600mm*	EZBMK-600	82281	2.4
	Centre Bar Mount Kit 750mm*	EZBMK-750	82282	2.6
	Centre Bar Mount Kit 900mm*	EZBMK-900	82283	3.4
	Centre Bar Mount Kit 1050mm*	EZBMK-1050	82284	3.6
	Centre Bar Mount Kit 1200mm*	EZBMK-1200	82285	4.4
	Centre Bar Mount Kit 1350mm*	EZBMK-1350	82286	4.8
	Centre Bar Mount Kit 1500mm*	EZBMK-1500	82287	5.6
	Centre Bar Mount Kit 1800mm*	EZBMK-1800	82288	6.6
6	Wing Plate Kit 600mm*	EZWPK-600	82345	7.7
	Wing Plate Kit 750mm*	EZWPK-750	82346	7.9
	Wing Plate Kit 900mm*	EZWPK-900	82347	9.6
	Wing Plate Kit 1050mm*	EZWPK-1050	82348	11.9
	Wing Plate Kit 1200mm*	EZWPK-1200	82349	13.7
	Wing Plate Kit 1350mm*	EZWPK-1350	82350	16.1
	Wing Plate Kit 1500mm*	EZWPK-1500	82351	17.7
	Wing Plate Kit 1800mm*	EZWPK-1800	82352	21.2
7	Cross Stringer Kit 600mm*	EZCSK-600	82353	22.3
	Cross Stringer Kit 750mm*	EZCSK-750	82354	25.6
	Cross Stringer Kit 900mm*	EZCSK-900	82355	28.9
	Cross Stringer Kit 1050mm*	EZCSK-1050	82356	32.1
	Cross Stringer Kit 1200mm*	EZCSK-1200	82357	35.6
	Cross Stringer Kit 1350mm*	EZCSK-1350	82358	38.9
	Cross Stringer Kit 1500mm*	EZCSK-1500	82359	42.2
	Cross Stringer Kit 1800mm*	EZCSK-1800	82360	45.0
8	Shim Kit Medium Duty (incl. 4 shims)	SHIM-MDKIT	82394	9.3

*Hardware Included. Lead time: 4 weeks.

Replacement Quantities for EZIB-M

mm		600	750	900	1050	1200	1350	1500	1800
BARS REQUIRED	SLIDER	2	2	2	2	2	2	2	2
	IMPACT	4	4	5	7	8	10	11	12
BAR BOLT KITS REQUIRED		26	26	31	37	42	48	53	58
BAR SUPPORTS REQUIRED		4	4	5	5	6	6	7	8

It's the Structure, not the bars

It absorbs more impact to save your belt. Our exclusive Velocity Reduction Technology™ provides two levels of impact relief.

Level 1: **Impact Bars** first absorb impact energy. Unique Impact Bar Supports on all DRX™ Impact Beds allow the impact bars to function properly - expanding and absorbing more impact energy.

Level 2: On DRX200, 750 and 1500 impact beds, **Isolation Mounts** provide a second level of reaction force reduction, absorbing additional impact energy and minimising transmission back to the belt. The DRX3000 Dynamic has **Impact Energy Absorbers** to disperse an immense amount of impact, even in extremely severe applications.

User-Friendly Slide-Out Service™

- All DRX Impact Beds separate in the middle to slide apart and out.
- Can be easily and safely converted from the run position to the service position.
- Impact bars are easy to get to for changeout. A complete changeout can be done in one or two hours.

Unique Impact Bar Supports protect the impact bars from damage, extending service life. An Anti-Migratory Tab on each support secures the bar and prevents it from sliding in the direction of the belt.

Other Features and Benefits

- Uses exclusive anti-spin square washers. Allows use of carriage bolts to secure impact bars instead of expensive T bolts.
- Centre bars are tilted 3° inward to help centre the load on the belt.

How to spec the correct impact bed for your conveyor transfer point

Impact Energy Calculation Chart

Largest Material Lump Weight (w)

Drop Height (h)

ROLLER SIZE

127 mm 152 mm

Belt Width _____

Troughing Angle: 20° 35°

Bed Length: 1.2 M 1.5 M

IMPACT ENERGY

Lump Weight (w) _____

Drop Height (h) x _____

Total=kg/Mtr _____ See Below

Up to 25 kg-m—DRX200
 25 to 100 kg-m—DRX750
 100 to 200 kg-m—DRX1500
 200 to 400 kg-m—DRX3000

Product Ordering Information

DRX™200
Impact Beds

DRX™200

1.2 M Beds, 20° Trough

BELT WIDTH mm	ORDERING NUMBER	ITEM CODE	WT. KG.
600	DRXL-24-420	76816	118.2
750	DRXL-30-420	76817	128.2
900	DRXL-36-420	76818	146.8
1050	DRXL-42-420	76819	187.3
1200	DRXL-48-420	76820	196.8
1350	DRXL-54-420	76821	226.4
1500	DRXL-60-420	76822	246.8
1800	DRXL-72-420	76823	279.6

DRX200

1.5 M Beds, 20° Trough

BELT WIDTH mm	ORDERING NUMBER	ITEM CODE	WT. KG.
600	DRXL-24-520	76824	131.8
750	DRXL-30-520	76825	141.4
900	DRXL-36-520	76826	162.3
1050	DRXL-42-520	76827	208.6
1200	DRXL-48-520	76828	218.2
1350	DRXL-54-520	76829	251.8
1500	DRXL-60-520	76830	273.6
1800	DRXL-72-520	76831	308.6

DRX200

1.2 M Beds, 35° Trough

BELT WIDTH mm	ORDERING NUMBER	ITEM CODE	WT. KG.
600	DRXL-24-435	76832	118.2
750	DRXL-30-435	76833	128.2
900	DRXL-36-435	76834	146.8
1050	DRXL-42-435	76835	187.3
1200	DRXL-48-435	76836	196.8
1350	DRXL-54-435	76837	226.4
1500	DRXL-60-435	76838	246.8
1800	DRXL-72-435	76839	279.6

DRX200

1.5 M Beds, 35° Trough

BELT WIDTH mm	ORDERING NUMBER	ITEM CODE	WT. KG.
600	DRXL-24-535	76840	131.8
750	DRXL-30-535	76841	141.4
900	DRXL-36-535	76842	162.3
1050	DRXL-42-535	76843	208.6
1200	DRXL-48-535	76844	218.2
1350	DRXL-54-535	76845	251.8
1500	DRXL-60-535	76846	273.6
1800	DRXL-72-535	76847	308.6

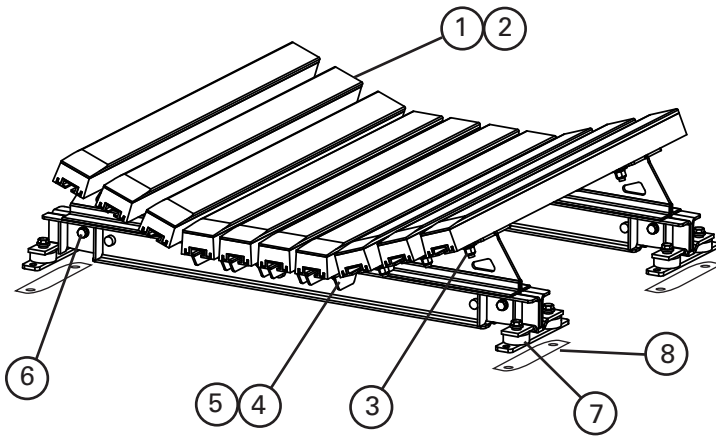

Replacement Bars and Bolt Kits Required per Belt Width-DRX200

BELT WIDTH mm	600	750	900	1050	1200	1350	1500	1800
Impact Bar Supports Required	2	2	3	4	4	4	5	6
Impact Bars Required	6	6	7	10	10	12	13	14
Impact Bar Bolt Kits Required	14	14	17	24	24	28	31	34

Replacement Parts

REF	DESCRIPTION	ORDERING NUMBER	ITEM CODE	WT. KG.
1	Impact Bar, 1.2 M	IB4	76926	7.7
2	Impact Bar, 1.5 M	IB5	76927	9.6
3	Impact Bar Bolt Kit incl. (1) ea 16 mm carriage bolt, square washer, flat washer, lock washer, Nylock nut	IBBK	76928	0.2
4	Impact Bar Support -L 1.2 M incl. (1) ea bar support, carriage bolt, square washer, lock washer, Nylock nut	IBS-L4	76929	7.6
5	Impact Bar Support -L 1.5 M incl. (1) ea bar support, carriage bolt, square washer, lock washer, Nylock nut	IBS-L5	76930	9.6
6	Sliding Support Arm Bolt Kit incl. (2) 50 mm bolts, (2) lock washers, (2) Nylock nuts	ISABK-LMH	77529	0.9
7	Isolation Mount Kit	IMK	76936	1.7
8	DRX200 Shim Kit (incl. 4 shims)	SHIM-KITL	77548	6.1

U.S. Patent No. 7,815,010; 9,296,564

Standard items: (shaded) are standard items. (unshaded) are optional items. (unshaded) are not standard items. (shaded) are not standard items. (unshaded) are not standard items.

Non-standard items: (unshaded) are non-standard items. (shaded) are non-standard items. (unshaded) are non-standard items. (shaded) are non-standard items.

Product Ordering Information

DRX™750
Impact Beds

DRX™750

1.2 M Beds, 20° Trough

BELT WIDTH mm	ORDERING NUMBER	ITEM CODE	WT. KG.
600	DRXM-24-420	76848	165.9
750	DRXM-30-420	76849	180.5
900	DRXM-36-420	76850	212.3
1050	DRXM-42-420	76851	269.1
1200	DRXM-48-420	76852	283.2
1350	DRXM-54-420	76853	320.0
1500	DRXM-60-420	76854	354.1
1800	DRXM-72-420	76855	407.3

DRX750

1.5 M Beds, 20° Trough

BELT WIDTH mm	ORDERING NUMBER	ITEM CODE	WT. KG.
600	DRXM-24-520	76856	183.2
750	DRXM-30-520	76857	197.7
900	DRXM-36-520	76858	233.6
1050	DRXM-42-520	76859	298.2
1200	DRXM-48-520	76860	312.3
1350	DRXM-54-520	76861	353.2
1500	DRXM-60-520	76862	391.4
1800	DRXM-72-520	76863	447.7

DRX750

1.2 M Beds, 35° Trough

BELT WIDTH mm	ORDERING NUMBER	ITEM CODE	WT. KG.
600	DRXM-24-435	76864	165.9
750	DRXM-30-435	76865	180.5
900	DRXM-36-435	76866	212.3
1050	DRXM-42-435	76867	269.1
1200	DRXM-48-435	76868	283.2
1350	DRXM-54-435	76869	320.0
1500	DRXM-60-435	76870	354.1
1800	DRXM-72-435	76871	407.3

DRX750

1.5 M Beds, 35° Trough

BELT WIDTH mm	ORDERING NUMBER	ITEM CODE	WT. KG.
600	DRXM-24-535	76872	183.2
750	DRXM-30-535	76873	197.7
900	DRXM-36-535	76874	233.6
1050	DRXM-42-535	76875	298.2
1200	DRXM-48-535	76876	312.3
1350	DRXM-54-535	76877	353.2
1500	DRXM-60-535	76878	391.4
1800	DRXM-72-535	76879	447.7

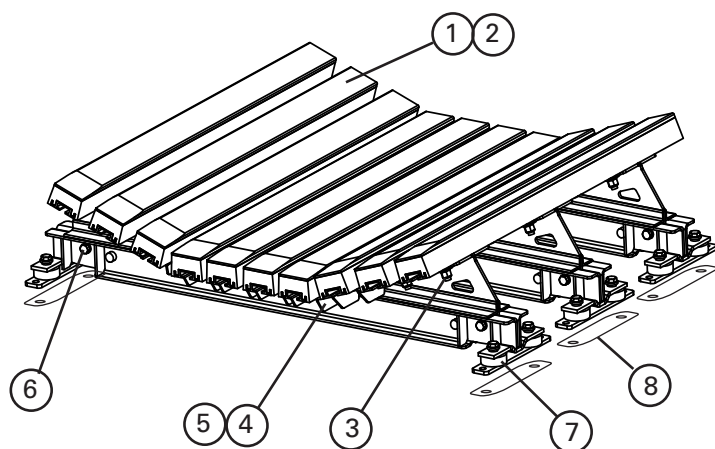

Replacement Parts

REF	DESCRIPTION	ORDERING NUMBER	ITEM CODE	WT. KG.
1	Impact Bar, 1.2 M	IB4	76926	7.7
2	Impact Bar, 1.5 M	IB5	76927	9.6
3	Impact Bar Bolt Kit incl. (1) ea 16 mm carriage bolt, square washer, flat washer, lock washer, Nylock nut	IBBK	76928	0.2
4	Impact Bar Support -M 1.2 M incl. (1) bar support, (2) ea carriage bolt, square washer, lock washer, Nylock nut	IBS-M4	76931	7.7
5	Impact Bar Support -M 1.5 M incl. (1) bar support, (2) ea carriage bolt, square washer, lock washer, Nylock nut	IBS-M5	76932	9.6
6	Sliding Support Arm Bolt Kit incl. (2) 50 mm bolts, (2) lock washers, (2) Nylock nuts	ISABK-LMH	77529	0.9
7	Isolation Mount Kit	IMK	76936	1.7
8	DRX750 Shim Kit (incl. 6 shims)	SHIM-KITM	77549	9.3

Replacement Bars and Bolt Kits Required per Belt Width-DRX750

BELT WIDTH mm	600	750	900	1050	1200	1350	1500	1800
Impact Bar Supports Required	4	4	5	6	6	6	7	8
Impact Bars Required	6	6	7	10	10	12	13	14
Impact Bar Bolt Kits Required	26	26	31	42	42	48	53	58

© 2011 Flexco. All rights reserved. Flexco and DRX are trademarks of Flexco. All other trademarks are the property of their respective owners.

U.S. Patent No. 7,815,010; 9,296,564

Product Ordering Information

DRX™ 1500
Impact Beds

DRX™1500

1.2 M Beds, 20° Trough

BELT WIDTH mm	ORDERING NUMBER	ITEM CODE	WT. KG.
600	DRXH-24-420	76880	228.6
750	DRXH-30-420	76881	247.7
900	DRXH-36-420	76882	285.5
1050	DRXH-42-420	76883	366.4
1200	DRXH-48-420	76884	385.0
1350	DRXH-54-420	76885	444.1
1500	DRXH-60-420	76886	484.6
1800	DRXH-72-420	76887	550.0

DRX1500

1.5 M Beds, 20° Trough

BELT WIDTH mm	ORDERING NUMBER	ITEM CODE	WT. KG.
600	DRXH-24-520	76888	253.6
750	DRXH-30-520	76889	273.2
900	DRXH-36-520	76890	314.6
1050	DRXH-42-520	76891	407.3
1200	DRXH-48-520	76892	425.9
1350	DRXH-54-520	76893	492.7
1500	DRXH-60-520	76894	536.8
1800	DRXH-72-520	76895	606.4

DRX1500

1.2 M Beds, 35° Trough

BELT WIDTH mm	ORDERING NUMBER	ITEM CODE	WT. KG.
600	DRXH-24-435	76896	228.6
750	DRXH-30-435	76897	247.7
900	DRXH-36-435	76898	285.5
1050	DRXH-42-435	76899	366.4
1200	DRXH-48-435	76900	385.0
1350	DRXH-54-435	76901	444.1
1500	DRXH-60-435	76902	484.6
1800	DRXH-72-435	76903	550.0

DRX1500

1.5 M Beds, 35° Trough

BELT WIDTH mm	ORDERING NUMBER	ITEM CODE	WT. KG.
600	DRXH-24-535	76904	253.6
750	DRXH-30-535	76905	273.2
900	DRXH-36-535	76906	314.6
1050	DRXH-42-535	76907	407.3
1200	DRXH-48-535	76908	425.9
1350	DRXH-54-535	76909	492.7
1500	DRXH-60-535	76910	536.8
1800	DRXH-72-535	76911	606.4

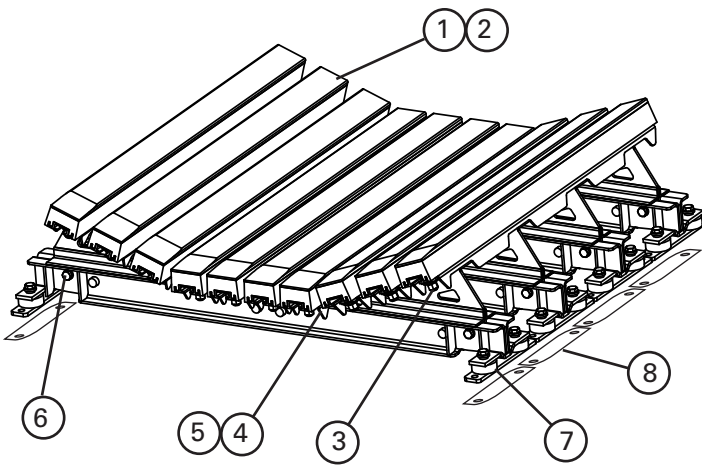

Replacement Parts

REF	DESCRIPTION	ORDERING NUMBER	ITEM CODE	WT. KG.
1	Impact Bar, 1.2 M	IB4	76926	7.7
2	Impact Bar, 1.5 M	IB5	76927	9.6
3	Impact Bar Bolt Kit incl. (1) ea 16 mm carriage bolt, square washer, flat washer, lock washer, Nylock nut	IBBK	76928	0.2
4	Impact Bar Support -H 1.2 M incl. (1) bar support, (2) ea carriage bolt, square washer, lock washer, Nylock nut	IBS-H4	76933	7.6
5	Impact Bar Support -DH 1.5 M incl. (1) bar support, (2) ea carriage bolt, square washer, lock washer, Nylock nut	IBS-DH5	76934	9.6
6	Sliding Support Arm Bolt Kit incl. (2) 50 mm bolts, (2) lock washers, (2) Nylock nuts	ISABK-LMH	77529	0.9
7	Isolation Mount Kit	IMK	76936	1.7
8	DRX1500 Shim Kit (incl. 8 shims)	SHIM-KITH	77550	12.3

Replacement Bars and Bolt Kits Required per Belt Width-DRX1500

BELT WIDTH mm	600	750	900	1050	1200	1350	1500	1800
Impact Bar Supports Required	6	6	7	10	10	12	13	14
Impact Bars Required	6	6	7	10	10	12	13	14
Impact Bar Bolt Kits Required	36	36	42	60	60	72	78	84

Stop! Do not use this information for any other purpose than the one intended. If you are not a Flexco customer, please do not use this information for any other purpose than the one intended.

No! Do not use this information for any other purpose than the one intended. If you are not a Flexco customer, please do not use this information for any other purpose than the one intended.

U.S. Patent No. 7,815,010; 9,296,564

Product Ordering Information

DRX™3000
Dynamic Beds

DRX™3000

1.5 M Beds, 20° Trough

BELT WIDTH mm	ORDERING NUMBER	ITEM CODE	WT. KG.
1050	DRXD-42-520	76912	614.1
1200	DRXD-48-520	76913	639.6
1350	DRXD-54-520	76914	712.7
1500	DRXD-60-520	76915	761.8
1800	DRXD-72-520	76916	953.6
2100	DRXD-84-520	76917	1027.7
2400	DRXD-96-520	76918	1185.9

DRX3000

1.5 M Beds, 35° Trough

BELT WIDTH mm	ORDERING NUMBER	ITEM CODE	WT. KG.
1050	DRXD-42-535	76919	614.1
1200	DRXD-48-535	76920	639.6
1350	DRXD-54-535	76921	712.7
1500	DRXD-60-535	76922	761.8
1800	DRXD-72-535	76923	953.6
2100	DRXD-84-535	76924	1027.7
2400	DRXD-96-535	76925	1185.9

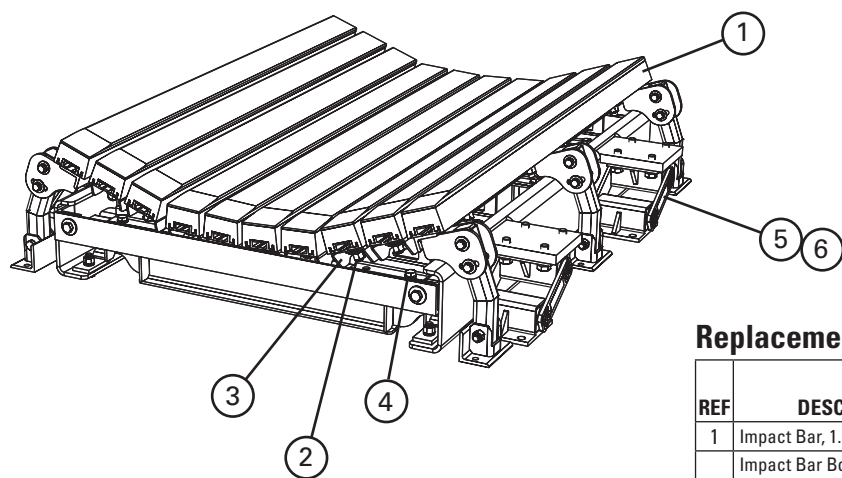

Replacement Bars and Bolt Kits Required per Belt Width-DRX3000

BELT WIDTH mm	1050	1200	1350	1500	1800	2100	2400
Impact Bars Required	10	10	12	13	16	16	20
Impact Bar Bolt Kits Required	56	56	64	70	88	88	112

Replacement Parts

REF	DESCRIPTION	ORDERING NUMBER	ITEM CODE	WT. KG.
1	Impact Bar, 1.5 M	IB5	76927	9.6
2	Impact Bar Bolt Kit incl. (1) ea 16 mm carriage bolt, square washer, flat washer, lock washer, Nylock nut	IBBK	76928	0.2
3	Impact Bar Support - DH 1.5 M incl. (1) bar support, (2) ea carriage bolt, square washer, lock washer, Nylock nut	IBS-DH5	76934	9.6
4	Sliding Support Arm Bolt Kit incl. (4) 38 mm bolts, (2) 51 mm bolts, (6) lock washers, (6) Nylock nuts	ISABK	76935	0.9
5	Impact Energy Absorber 42-60	IEA42-60D	76937	19.1
6	Impact Energy Absorber 72-96	IEA72-96D	76938	30.0

Impact Bar Supports per Belt Width

BELT WIDTH mm	1050	1200	1350	1500	1800	2100	2400
Impact Bar Supports	8	8	8	9	12	12	16

Product Notes:

- For extreme impact applications up to 400 kgs.-M (lump size x drop height).
- Impact Energy Absorbers compress up to 75 mm to absorb extreme impact energy to minimize damaging forces and protect the belt.
- Slide-Out System™ allows direct access to service the impact bars.

Selecções de materiais e de referências são apenas sugestões, não obrigatórias e não representam garantia de desempenho. Consulte o manual de instruções para mais detalhes.

Material selection and references are only suggestions and do not represent a guarantee of performance. Consult the instruction manual for more details.

U.S. Patent No. 7,815,010; 9,296,564

Product Ordering Information

DRX™ Impact Beds Optional Parts and Tools

Impact Bars with 25 mm UHMW

For impact beds that have heavy abrasive wear on the impact bars.

DESCRIPTION	ORDERING NUMBER	ITEM CODE	WT. KG.
1.2 M Impact Bar with 25 mm UHMW	IB4-1U	76965	7.7
1.5 M Impact Bar with 25 mm UHMW	IB5-1U	76966	9.6

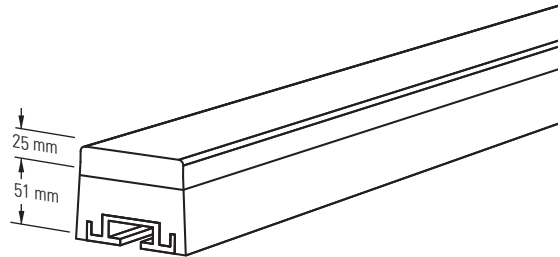

Impact Bar with 25 mm UHMW Cover

Impact Bar Bolt Kit for Other OEM Impact Beds*

13 mm carriage bolts, square washer, flat washer and Nylock nut to mount DRX Impact Bars on other OEM beds that use 13 mm T-bolts.

DESCRIPTION	ORDERING NUMBER	ITEM CODE	WT. KG.
Optional Impact Bar Bolt Kit	OIBBK	76950	0.2

*Kit includes 1 ea. bolt, square washer, flat washer and nut.

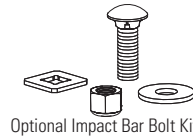

Optional Impact Bar Bolt Kit

Impact Bed Handy Wrench

A ratcheting wrench with 2 common socket sizes 19 mm & 24 mm for installation and maintenance of impact beds.

DESCRIPTION	ORDERING NUMBER	ITEM CODE	WT. KG.
Impact Bed Handy Wrench	HW-IMPB	76939	0.7

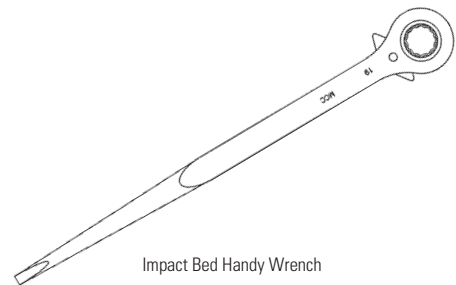

Impact Bed Handy Wrench

 **Stock items** (non-shaded) refer to (*) for specific lead time, if not specified, standard lead time applies.

 **Non-stock items** (shaded) please contact Flexco for dispatch options and lead times.

Product Ordering Information

V-Plough

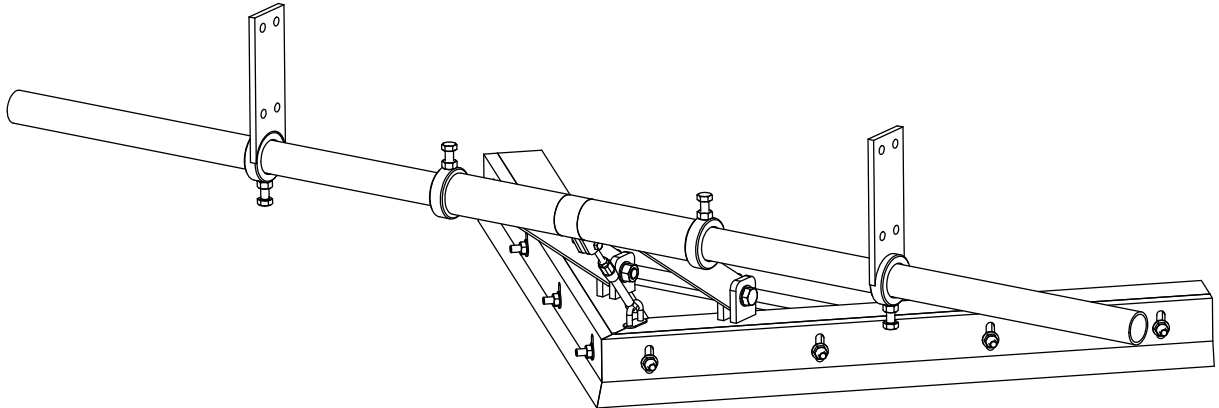

Deflector™ V Plough-Mild Steel

BELT WIDTH mm	ORDERING NUMBER	ITEM CODE	WT. KG.
450	BP450	73102	23
600	BP600	73104	25
750	BP750	73106	26
800	BP800	73107	28
900	BP900	73108	29
1050	BP1050	73110	31
1200	BP1200	73112	38
1400	BP1400	73113	42
1500	BP1500	73114	43
1600	BP1600	73115	44
1800	BP1800	73117	65

Note: Polyurethane Blades are approved for use in underground mines.
For belt widths over 1800 mm contact Flexco®.

Deflector™ V Plough-Stainless Steel

BELT WIDTH mm	ORDERING NUMBER	ITEM CODE	WT. KG.
450	BP450-S/S	76337	24
600	BP600-S/S	76338	25
750	BP750-S/S	76339	27
800	BP800-S/S	76340	29
900	BP900-S/S	76341	30
1050	BP1050-S/S	76342	32
1200	BP1200-S/S	76343	39
1400	BP1400-S/S	76344	44
1500	BP1500-S/S	76345	45
1600	BP1600-S/S	76346	46
1800	BP1800-S/S	76347	67

Note: Polyurethane Blades are approved for use in underground mines.
For belt widths over 1800 mm contact Flexco.

Product Notes:

- Exclusive blade design - 20° slant on leading edge spirals debris off the belt.
- Self-adjusting blade - the blade floats on the belt and self-adjusts as it wears.
- Unique blade adjuster - turnbuckle-type adjuster allows the blade to be accurately positioned to the belt.
- Easy to install - comes fully assembled and can be placed right into position on the conveyor.

Stock items (non-shaded) refer to (*) for specific lead time, if not specified, standard lead time applies.

Non-stock items (shaded) please contact Flexco for dispatch options and lead times.

Replacement Parts List

V-Plough

Replacement Parts		POWDER COATED			STAINLESS STEEL		
DESCRIPTION	BELT WIDTH mm	ORDERING NUMBER	ITEM CODE	WT. KG.	ORDERING NUMBER	ITEM CODE	WT. KG.
PL Pole	450-750	BP450-750-PL	73109	2.8	BP450-750-PL-S/S	A0683	2.7
	800-1050	BP800-1050-PL	73111	3.2	BP800-1050-PL-S/S	A0613	3.2
	1200-1400	BP1200-1400-PL	73118	3.6	BP1200-1400-PL-S/S	A0621	3.6
	1500-1600	BP1500-1600-PL	73119	4.6	BP1500-1600-PL-S/S	A0647	5.0
	1800	BP1800-PL	73121	5.5	BP1800-PL-S/S	A1547	5.9
Frame	450-750	BP450-750MF	73152	6.7	BP450-750MF-S/S MAIN FRAME	A0682	6.7
	800-1050	BP800-1050MF	73153	9.8	BP800-1050MF-S/S MAIN FRAME	A0612	9.8
	1200-1400	BP1200-1400MF	73154	12.6	BP1200-1400MF-S/S MAIN FRAME	A0620	12.6
	1500-1600	BP1500-1600MF	73147	16.0	BP1500-1600MF-S/S MAIN FRAME	A0646	16.0
	1800	BP1800MF	73148	18.3	BP1800MF-S/S MAIN FRAME	A1546	18.3
	2000	BP2000MF	A1996	19.7			
Blades - Polyurethane Pair - 110mm	450	BP450-B	74055	0.9			
	600	BP600-B	73777	0.9			
	750	BP750-B	73778	1.8			
	800	BP800-B	74057	1.8			
	900	BP900-B	73779	1.8			
	1050	BP1050-B	73780	1.8			
	1200	BP1200-B	73781	1.8			
	1400	BP1400-B	73782	2.3			
	1500	BP1500-B	73783	2.7			
	1600	BP1600-B	73784	2.7			
Blades - Polyurethane Pair - 180mm (Heavy-Duty)	750	HBP750-B	A0223	5.2			
	900	HBP900-B	A0224	6.3			
	1050	HBP1050-B	A2237	7.2			
	1200	HBP1200-B	73301	8.4			
	1400	HBP1400-B	73302	9.7			
	1500	HBP1500-B	73303	10.6			
	1600	HBP1600-B	73304	11.6			
	1800	HBP1800-B	73306	13.0			
	2000	HBP2000-B	73307	14.5			
	2200	HBP2200-B	73308	15.9			
	2400	HBP2400-B	73309	16.9			
	2500	HBP2500-B	73311	17.8			
Mounting Bracket		BP-MB	73123	0.5	BP-MB-S/S	A0615	0.5
Shaft Collar		BP-SC	73125	0.5	BP-SC-S/S	A0616	0.5
Linkage Arm		BP-LA	73127	0.9	BP-LA-S/S	A0614	0.9
Turnbuckle Linkage		BP-TL	73141	0.5	BP-TL-S/S	A0617	0.5
Standard Turnbuckle					BP-TB	73138	0.5
Standard U-Bolt					BP-UB	73139	0.5

Lead time: 3 weeks

Stock items (non-shaded) refer to (*) for specific lead time, if not specified, standard lead time applies.

Non-stock items (shaded) please contact Flexco for dispatch options and lead times.

Product Ordering Information

Twin Pole V-Plough



Deflector™ Twin Pole V Plough-Mild Steel UHMPE Blade

BELT WIDTH mm	ORDERING NUMBER	ITEM CODE	WT. KG.
900	HBP900-TP	A2283	93.0
1050	HBP1050-TP	A2284	99.0
1200	HBP1200-TP	A2285	106.0
1400	HBP1400-TP	A2286	115.0
1500	HBP1500-TP	A2287	119.0
1600	HBP1600-TP	A2288	124.0
1800	HBP1800-TP	A2289	133.0
2000	HBP2000-TP	A2290	142.0
2200	HBP2200-TP	A2291	151.0
2400	HBP2400-TP	A2292	162.0
2500	HBP2500-TP	A2293	165.0

Note: Scraping blades are UHMPE material.
Blades are not FRAS approved.
For belt widths over 2500 mm contact Flexco®.
Lead time: 3 weeks

Deflector™ Twin Pole V Plough-Stainless Steel UHMPE Blade

BELT WIDTH mm	ORDERING NUMBER	ITEM CODE	WT. KG.
900	HBP-TP-900 S/S	A2474	94.0
1050	HBP-TP-1050 S/S	A2475	100.0
1200	HBP-TP-1200 S/S	A2476	107.0
1400	HBP-TP-1400 S/S	A2477	116.0
1500	HBP-TP-1500 S/S	A2478	120.0
1600	HBP-TP-1600 S/S	A2479	125.0
1800	HBP-TP-1800 S/S	A2480	134.0
2000	HBP-TP-2000 S/S	A2481	143.0
2200	HBP-TP-2200 S/S	A2482	152.0
2400	HBP-TP-2400 S/S	A2483	163.0
2500	HBP-TP-2500 S/S	A2484	166.0

Note: Scraping blades are UHMPE material.
Blades are not FRAS approved.
For belt widths over 2500 mm contact Flexco.
Lead time: 3 weeks

Stock items (non-shaded) refer to (*) for specific lead time, if not specified, standard lead time applies.

Non-stock items (shaded) please contact Flexco for dispatch options and lead times.

Replacement Parts List

Twin Pole V-Plough

Replacement Parts		POWDER COATED			STAINLESS STEEL		
DESCRIPTION	BELT WIDTH mm	ORDERING NUMBER	ITEM CODE	WT. KG.	ORDERING NUMBER	ITEM CODE	WT. KG.
PL Pole	900	HBP900-PL-TP	A2294	14.0	HBP900-PL-TP-S/S	A2492	15.0
	1050	HBP1050-PL-TP	A2295	15.0	HBP1050-PL-TP-S/S	A2493	16.0
	1200	HBP1200-PL-TP	A2296	16.0	HBP1200-PL-TP-S/S	A2494	17.0
	1400	HBP1400-PL-TP	A2297	18.0	HBP1400-PL-TP-S/S	A2495	19.0
	1500	HBP1500-PL-TP	A2298	20.0	HBP1500-PL-TP-S/S	A2496	21.0
	1600	HBP1600-PL-TP	A2299	21.0	HBP1600-PL-TP-S/S	A2497	22.0
	1800	HBP1800-PL-TP	A2300	22.0	HBP1800-PL-TP-S/S	A2498	23.0
	2000	HBP2000-PL-TP	A2301	24.0	HBP2000-PL-TP-S/S	A2499	25.0
	2200	HBP2200-PL-TP	A2303	26.0	HBP2200-PL-TP-S/S	A2500	27.0
	2400	HBP2400-PL-TP	A2302	28.0	HBP2400-PL-TP-S/S	A2501	29.0
	2500	HBP2500-PL-TP	A2304	29.0	HBP2500-PL-TP-S/S	A2502	30.0
Frame	900	HBP900-MF-TP	A2305	26.0	HBP900-MF-TP-S/S	A2504	27.0
	1050	HBP1050-MF-TP	A2306	28.0	HBP1050-MF-TP-S/S	A2505	29.0
	1200	HBP1200-MF-TP	A2307	30.0	HBP1200-MF-TP-S/S	A2506	31.0
	1400	HBP1400-MF-TP	A2308	33.0	HBP1400-MF-TP-S/S	A2507	34.0
	1500	HBP1500-MF-TP	A2309	34.0	HBP1500-MF-TP-S/S	A2508	35.0
	1600	HBP1600-MF-TP	A2310	35.5	HBP1600-MF-TP-S/S	A2509	36.5
	1800	HBP1800-MF-TP	A2311	38.0	HBP1800-MF-TP-S/S	A2510	39.0
	2000	HBP2000-MF-TP	A2312	41.0	HBP2000-MF-TP-S/S	A2511	42.0
	2200	HBP2200-MF-TP	A2314	44.0	HBP2200-MF-TP-S/S	A2512	45.0
	2400	HBP2400-MF-TP	A2313	52.0	HBP2400-MF-TP-S/S	A2513	53.0
	2500	HBP2500-MF-TP	A2315	54.0	HBP2500-MF-TP-S/S	A2514	55.0
Blades	900	HBP900-B-TP	A2316	4.5			
	1050	HBP1050-B-TP	A2317	5.0			
	1200	HBP1200-B-TP	A2318	5.5			
	1400	HBP1400-B-TP	A2319	6.3			
	1500	HBP1500-B-TP	A2320	7.0			
	1600	HBP1600-B-TP	A2321	7.5			
	1800	HBP1800-B-TP	A2322	8.2			
	2000	HBP2000-B-TP	A2323	9.0			
	2200	HBP2200-B-TP	A2325	9.8			
	2400	HBP2400-B-TP	A2324	10.7			
	2500	HBP2500-B-TP	A2326	11.2			
Linkage Arm	900-2500	HBP-LA-TP	A2330	5.0	HBP-LA-TP-S/S	A2515	5.0
Mounting Bracket	900-2500	HBP-MB-TP	73922	2.1	HBP-MB-TP-S/S	A1155	2.1
Shaft Collar	900-2500	HBP-SC-TP	74490	0.7	HBP-SC-TP-S/S	A2189	0.7

Lead time: 3 weeks

Stock items (non-shaded) refer to (*) for specific lead time, if not specified, standard lead time applies.

Non-stock items (shaded) please contact Flexco for dispatch options and lead times.

Product Ordering Information

HD[®] Floating V-Plough



HD[®] Floating V Plough-Mild Steel UHMPE Blade

BELT WIDTH mm	ORDERING NUMBER	ITEM CODE	WT. KG.
900	FBP900-TP	61750	133
1050	FBP1050-TP	61751	137
1200	FBP1200-TP	61752	163
1400	FBP1400-TP	61753	167
1500	FBP1500-TP	61754	189
1600	FBP1600-TP	61755	192
1800	FBP1800-TP	61756	218
2000	FBP2000-TP	61757	224
2200	FBP2200-TP	61758	256
2400	FBP2400-TP	61759	261
2500	FBP2500-TP	61760	284
2600	FBP2600-TP	61761	287

Note: Scraping blades are UHMPE material.
Blades are not FRAS approved.
For belt widths over 2600 mm contact Flexco[®].
Lead time: 3 weeks

HD Floating V Plough Stainless Steel UHMPE Blade

BELT WIDTH mm	ORDERING NUMBER	ITEM CODE	WT. KG.
900	FBP900-TP S/S	61765	135
1050	FBP1050-TP S/S	61766	141
1200	FBP1200-TP S/S	61767	167
1400	FBP1400-TP S/S	61768	171
1500	FBP1500-TP S/S	61769	194
1600	FBP1600-TP S/S	61770	197
1800	FBP1800-TP S/S	61771	224
2000	FBP2000-TP S/S	61772	230
2200	FBP2200-TP S/S	61773	263
2400	FBP2400-TP S/S	61774	268
2500	FBP2500-TP S/S	61775	291
2600	FBP2600-TP S/S	61776	294

Note: Scraping blades are UHMPE material.
Blades are not FRAS approved.
For belt widths over 2600 mm contact Flexco.
Lead time: 3 weeks

Replacement Blades

UHMPE - pair

BELT WIDTH mm	ORDERING NUMBER	ITEM CODE	WT. KG.
900	FBP900-B	61780	11.0
1050	FBP1050-B	61781	12.6
1200	FBP1200-B	61782	14.3
1400	FBP1400-B	61783	16.4
1500	FBP1500-B	61784	17.5
1600	FBP1600-B	61785	18.5
1800	FBP1800-B	61786	20.5
2000	FBP2000-B	61787	22.6
2200	FBP2200-B	61788	24.6
2400	FBP2400-B	61789	26.7
2500	FBP2500-B	61790	28.3
2600	FBP2600-B	61791	29.8

Lead time: 3 weeks

Product Notes:

- Cleans the inside/clean side of the return belt.
- Eliminates conveyor damage and belt mistracking caused by debris lodging in the tail pulley or take-up.
- Floating design self-adjusts as blade wears, eliminating the need for manual adjustment.
- Available in a range of sizes for multiple belt widths.
- Removes carryback on both sides of the conveyor
- UHMWPE blades provide long life and easy change-out.

 Stock items (non-shaded) refer to (*) for specific lead time, if not specified, standard lead time applies.

 Non-stock items (shaded) please contact Flexco for dispatch options and lead times.

Replacement Parts List

HD® Floating V-Plough

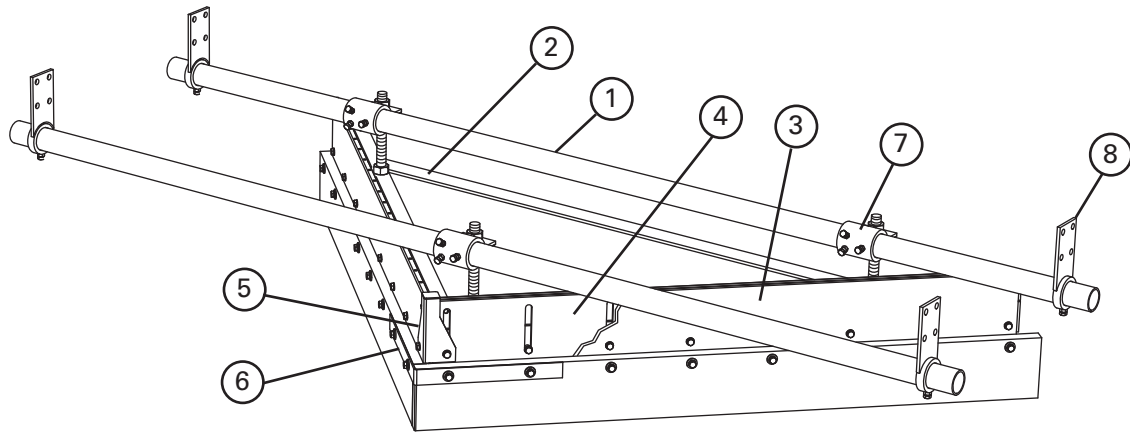

Replacement Parts

REF	DESCRIPTION	BELT WIDTH mm	MILD STEEL			STAINLESS STEEL		
			ORDERING NUMBER	ITEM CODE	WT. KG.	ORDERING NUMBER	ITEM CODE	WT. KG.
1	Pole	900	HBP900-PL-TP	A2294		HBP900-PL-TP-S/S	A2492	
		1050	HBP1050-PL-TP	A2295		HBP1050-PL-TP-S/S	A2493	
		1200	HBP1200-PL-TP	A2296		HBP1200-PL-TP-S/S	A2494	
		1400	HBP1400-PL-TP	A2297		HBP1400-PL-TP-S/S	A2495	
		1500	HBP1500-PL-TP	A2298		HBP1500-PL-TP-S/S	A2496	
		1600	HBP1600-PL-TP	A2299		HBP1600-PL-TP-S/S	A2497	
		1800	HBP1800-PL-TP	A2300		HBP1800-PL-TP-S/S	A2498	
		2000	HBP2000-PL-TP	A2301		HBP2000-PL-TP-S/S	A2499	
		2200	HBP2200-PL-TP	A2303		HBP2200-PL-TP-S/S	A2500	
		2400	HBP2400-PL-TP	A2302		HBP2400-PL-TP-S/S	A2501	
		2500	HBP2500-PL-TP	A2304		HBP2500-PL-TP-S/S	A2502	
		2600	HBP2600-PL-TP	A0151		HBP2600-PL-TP-S/S	61877	
2	Frame	900-1050	FBP900-1050-MF	61795		FBP900-1050-MF-S/S	61803	
		1200-1400	FBP1200-1400-MF	61796		FBP1200-1400-MF-S/S	61804	
		1500-1600	FBP1500-1600-MF	61797		FBP1500-1600-MF-S/S	61805	
		1800-2000	FBP1800-2000-MF	61798		FBP1800-2000-MF-S/S	61806	
		2200-2400	FBP2200-2400-MF	61799		FBP2200-2400-MF-S/S	61807	
		2500-2600	FBP2500-2600-MF	61800		FBP2500-2600-MF-S/S	61808	
3	Protection Plate Kit	900-1050	FBP900-1050-PP	61890		FBP900-1050-PP-S/S	61898	
		1200-1400	FBP1200-1400-PP	61891		FBP1200-1400-PP-S/S	61899	
		1500-1600	FBP1500-1600-PP	61892		FBP1500-1600-PP-S/S	61900	
		1800-2000	FBP1800-2000-PP	61893		FBP1800-2000-PP-S/S	61901	
		2200-2400	FBP2200-2400-PP	61894		FBP2200-2400-PP-S/S	61902	
4	Slotted Plate Kit	2500-2600	FBP2500-2600-PP	61895		FBP2500-2600-PP-S/S	61903	
		900-1050	FBP900-1050-SP	61906		FBP900-1050-SP-S/S	61914	
		1200-1400	FBP1200-1400-SP	61907		FBP1200-1400-SP-S/S	61915	
		1500-1600	FBP1500-1600-SP	61908		FBP1500-1600-SP-S/S	61916	
		1800-2000	FBP1800-2000-SP	61909		FBP1800-2000-SP-S/S	61917	
5	Nose Protection	All	FBP-NP	61875		FBP-NP-S/S	61876	
6	Faceplate	All	FBP-FP	61888		FBP-FP-S/S	61889	
7	Linkage Mount Kit	All	FBP-LM	61882		FBP-LM-S/S	61883	
8	Mounting Bracket	All	HBP-MB-TP	73922		HBP-MB-TP-S/S	A1155	

Lead time: 3 weeks

Stock items (non-shaded) refer to (*) for specific lead time, if not specified, standard lead time applies.

Non-stock items (shaded) please contact Flexco for dispatch options and lead times.

Product Ordering Information

Diagonal Plough

Diagonal Ploughs - Mild Steel*

BELT WIDTH mm	ORDERING NUMBER	ITEM CODE	WT. KG.
450-750	CBD-S	76442	20.0
900-1050	CBD-M	76443	25.0
1200-1500	CBD-L	76444	32.0
1600-1800	CBD-XL	76445	43.0
2000-2400	CBD-XXL	64787	54.0

*Use next larger size for Belt Widths between ranges.



Diagonal Plough* - Stainless Steel*

BELT WIDTH mm	ORDERING NUMBER	ITEM CODE	WT. KG.
450-750	CBD-S-S/S	64178	20.0
900-1050	CBD-M-S/S	A1854	25.0
1200-1500	CBD-L-S/S	A1856	32.0
1600-1800	CBD-XL-S/S	76318	43.0
2000-2400	CBD-XXL-S/S	63554	54.0

*Use next larger size for Belt Widths between ranges.

Replacement Blade Kits-Polyurethane Blades

BELT WIDTH mm	ORDERING NUMBER	ITEM CODE	WT. KG.
450-750	DBK-S	76446	2.0
900-1050	DBK-M	76447	3.0
1200-1500	DBK-L	76448	4.0
1600-2000	DBK-XL	76449	5.0
2100-2400	DBK-XXL	62595	6.0

Kit includes blade and replacement blade bolts.
Diagonal Plough requires 1 blade; Reversing Plough requires 2 blades.

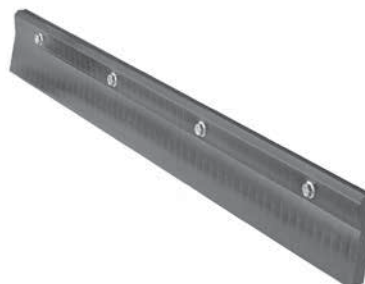

Deflector™ Reversible Plough with Polyurethane Blades-Mild Steel

BELT WIDTH mm	ORDERING NUMBER	ITEM CODE	WT. KG.
450-750	CBR-S	72483	40.0
900-1050	CBR-M	72484	48.0
1200-1500	CBR-L	72485	60.0
1600-2000	CBR-XL	72486	80.0

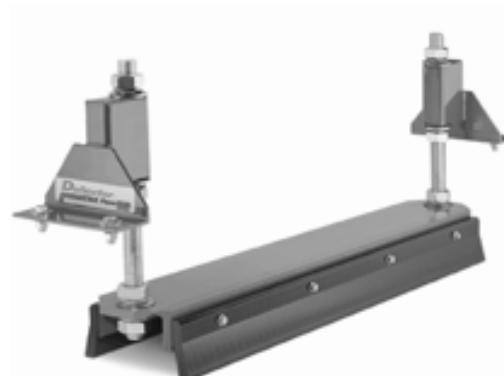

Product Notes:

- A belt cleaner for the tail pulley. Prevents damage to the belt, pulley, lagging, and belt splice.
- Keeps fugitive materials off the inside of the belt and out of the tail pulley.
- Installed at a 45° angle across the belt to discharge material to one predetermined side.
- The blade is installed in a fixed position, eliminating any bouncing problems.
- Exclusive 20° angled blade quickly spirals material off the belt.

 Stock items (non-shaded) refer to (*) for specific lead time, if not specified, standard lead time applies.

 Non-stock items (shaded) please contact Flexco for dispatch options and lead times.

Product Ordering Information & Replacement Parts

Diagonal Plough
HD® Spring Tensioned

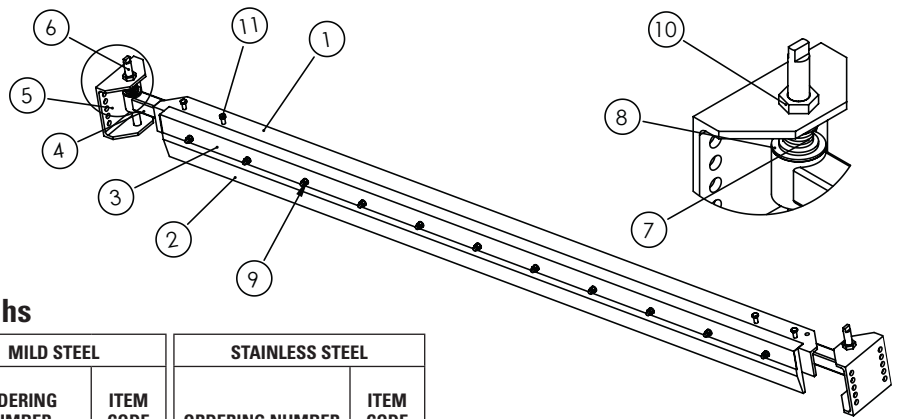

HD® Spring Tensioned Diagonal Ploughs

DESCRIPTION	BELT WIDTH mm	MILD STEEL		STAINLESS STEEL	
		ORDERING NUMBER	ITEM CODE	ORDERING NUMBER	ITEM CODE
Heavy-Duty Spring Tensioned Diagonal Plough	900-1050	CBD-ST-M	61077	CBD-ST-M-S/S	61079
	1200-1500	CBD-ST-L	61050	CBD-ST-L-S/S	61080
	1600-1800	CBD-ST-XL	61051	CBD-ST-XL-S/S	A2138
	2000-2400	CBD-ST-XXL	63747	CBD-ST-XXL-S/S	63748
Heavy-Duty Spring Tensioned Diagonal Plough with Polyurethane Blade	900-1050	CBD-ST-M-P	64772	CBD-ST-M-P-S/S	64623
	1200-1500	CBD-ST-L-P	64773	CBD-ST-L-P-S/S	64624
	1600-1800	CBD-ST-XL-P	64774	CBD-ST-XL-P-S/S	64625
	2000-2400	CBD-ST-XXL-P	64775	CBD-ST-XXL-P-S/S	64626
Heavy-Duty Spring Tensioned Diagonal Plough with Polyurethane Blade and Shield	900-1050	CBD-ST-M-PSS	64776	CBD-ST-M-PS-S/S	64780
	1200-1500	CBD-ST-L-PS	64777	CBD-ST-L-PS-S/S	64781
	1600-1800	CBD-ST-XL-PS	64778	CBD-ST-XL-PS-S/S	64782
	2000-2400	CBD-ST-XXL-PS	64779	CBD-ST-XXL-PS-S/S	64783

Lead time: 3 weeks

Replacement Parts

REF	DESCRIPTION	BELT WIDTH mm	BLADE WIDTH mm	MILD STEEL		STAINLESS STEEL	
				ORDERING NUMBER	ITEM CODE	ORDERING NUMBER	ITEM CODE
1	Diagonal Plough Main Frame	900-1050	N/A	CBD-ST-M-MF	61105	CBD-ST-M-MF-S/S	61108
		1200-1500	N/A	CBD-ST-L-MF	61106	CBD-ST-L-MF-S/S	61109
		1600-1800	N/A	CBD-ST-XL-MF	61107	CBD-ST-XL-MF-S/S	61110
		2000-2400	N/A	CBD-ST-XXL-MF	63749	CBD-ST-XXL-MF-S/S	63750
2	Standard Blade (FRAS)	900-1050	1750	CBD-ST-FR-B	61111		
		1200-1500	2250	CBD-ST-L-FR-B	A2218		
		1600-1800	2750	CBD-ST-XL-FR-B	A1784		
		2000-2400	3250	CBD-ST-XXL-FR-B	63752		
	Polyurethane Blade	900-1050	1750	CBD-ST-B	64620		
		1200-1500	2250	CBD-ST-L-B	64621		
		1600-1800	2750	CBD-ST-XL-B	64482		
		2000-2400	3250	CBD-ST-XXL-B	64622		
3	Stainless Steel Face Plate	900-1050	N/A	CBD-ST-M-FP	61112		
		1200-1500	N/A	CBD-ST-L-FP	61113		
		1600-1800	N/A	CBD-ST-XL-FP	61114		
		2000-2400	N/A	CBD-ST-XXL-FP	63751		
-	Diagonal Plough Shields	900-1050	N/A	CBD-ST-M-S	64784		
		1200-1500	N/A	CBD-ST-L-S	64785		
		1600-1800	N/A	CBD-ST-XL-S	63024		
		2000-2400	N/A	CBD-ST-XXL-S	63791		
4	Adjusting Arm	N/A		CBD-ST-AA	61096		
5	Mounting Channel	N/A		CBD-ST-MC	B0092		
6	Threaded Bar	N/A		CBD-ST-TB-S/S	A2629		
7	Compression Spring	N/A		CBD-ST-CS-S/S	A2215		
8	Poly Bush	N/A		CBD-ST-PB	A2449		
	Bush with Brass Insert	N/A		CBD-ST-BB	64310		
9	M12 NYLOC, S/S 316 nut & flat washer	N/A		N/A	N/A		
10	Fasteners kit (M24 half nuts & flat washers - SS304) Qty: 4 each	N/A		CBD-ST-HN-S/S	61100		
11	M12 X40 Hex bolt & nuts (SS316) Qty: 8 each	N/A		N/A	N/A		

Lead time: 3 weeks

Product Ordering Information

Belt Positioner™

Belt Positioners with CoreTech™ Rollers

SIZE	BELT WIDTH (MIN-MAX) mm	POSITIONER WIDTH (MIN-MAX) mm	ORDERING NUMBER	ITEM CODE	WT. KG.
Small	450-600	600-850	PSR-S	74558	29.2
Medium	750-1200	850-1400	PSR-M	74559	34.5
Large	1350-1800	1400-2075	PSR-L	74560	44.3
Extra Large	1800-2400	1800-3000	PSR-XL	74561	82.1

Note:

- Use next larger size for belt widths between ranges.
- Idler rollers on sizes:
 - S-M-L are 127 mm diameter
 - X are 152 mm diameter
- Finish: All steel parts are powder coated. All nuts and set screws are metric in 300 series Stainless Steel.
- This product is also available in Stainless Steel. Please contact Flexco® for pricing.





Belt Positioners with Steel Rollers

SIZE	BELT WIDTH (MIN-MAX) mm	POSITIONER WIDTH (MIN-MAX) mm	ORDERING NUMBER	ITEM CODE	WT. KG.
Small	450-600	600-850	PSR-S-F	62350	31.7
Medium	750-1200	850-1400	PSR-M-F	62351	38.5
Large	1350-1800	1400-2075	PSR-L-F	62352	49.8
Extra Large	1800-2400	1800-3000	PSR-XL-F	62353	90.7

Product Notes:

- The Positioner should be centered between two standard return rollers. For general applications-standard belts up to 1800 mm: position the unit no closer than 900 mm to a return roller and no farther than 1.8 meters.
- Works on the return side of the conveyor using simple angled rollers mounted in a fixed position to quickly and continuously funnel the belt into the correct path.
- A “quick fix” solution for belts that consistently wander to one side.
- Typically installed before the tail pulley to keep the belt centred at the critical loading point. Centre loading is the key to solving many top side tracking problems.
- Idler rollers make smooth contact with the return belt’s bottom cover, eliminating excessive wear and damage to the belt’s edges.
- Has no pivoting mechanism to freeze up and cause the unit to stop working.
- Once installed, no further adjustment is required.

 **Stock items** (non-shaded) refer to (*) for specific lead time, if not specified, standard lead time applies.

 **Non-stock items** (shaded) please contact Flexco for dispatch options and lead times.

Replacement Parts List

Belt Positioner™

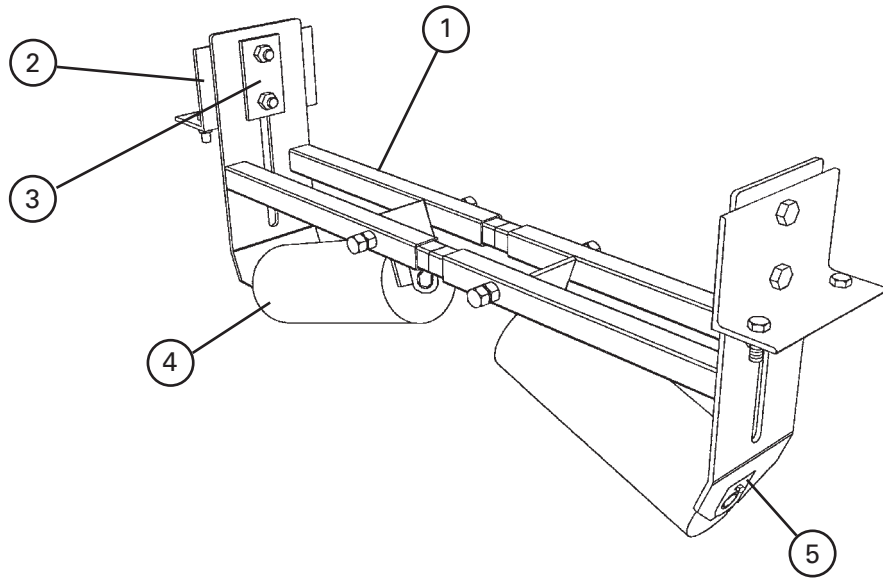

Replacement Parts

REF	DESCRIPTION	BELT WIDTH (MIN-MAX) mm	ORDERING NUMBER	ITEM CODE	WT. KG.
1	Small Frame Kit* (1 ea.)	450-650	RBPFK-S	73946	5.7
	Medium Frame Kit* (1 ea.)	750-1200	RBPFK-M	73947	6.5
	Large Frame Kit* (1ea.)	1350-1600	RBPFK-L	73948	8.8
	Extra Large Frame Kit* (1 ea.)	1800-2400	RBPFK-XL	73949	13.0
2	Mounting Bracket Kit* (1 ea.)		RBPMBK	74327	2.7
3	Clamp Plate	450-2400	RBPCP	73162	0.5

* Hardware included

Replacement Rollers

REF	DESCRIPTION	ORDERING NUMBER	ITEM CODE	WT. KG.
4	Small Steel Roller	RBPSR-S	74562	5.5
	Medium Steel Roller	RBPSR-M	74563	7.5
	Large Steel Roller	RBPSR-L	74564	10.5
	Extra Large Steel Roller	RBPSR-XL	74565	16.6
	Small CoreTech™ Roller	RBPSR-S-CCT	28250	3
	Medium CoreTech Roller	RBPSR-M-CCT	28251	3.5
	Large CoreTech Roller	RBPSR-L-CCT	28253	5
	Extra Large CoreTech Roller	RBPSR-XL-CCT	28254	8
5	Roller Retainer Kit*	RBPRET	A1622	0.2

Positioners come standard with Steel rollers.

Stock items (non-shaded) refer to (*) for specific lead time, if not specified, standard lead time applies.

Non-stock items (shaded) please contact Flexco for dispatch options and lead times.

Product Ordering Information

PTEZ™
Belt Trainer

PTEZ™ Belt Trainer

BELT WIDTH		ORDERING NUMBER	ITEM CODE	WT. Kg.
mm	in.			
450	18	PTEZ-450	90265	54.4
600	24	PTEZ-600	90266	58.9
750	30	PTEZ-750	90267	63.5
900	36	PTEZ-900	90268	68
1050	42	PTEZ-1050	90269	72.6
1200	48	PTEZ-1200	90270	77.1



HD PTEZ™ Belt Trainer

BELT WIDTH		ORDERING NUMBER	ITEM CODE	WT. Kg.
mm	in.			
1050	42	PTEZHD-1050	90616	103.6
1200	48	PTEZHD-1200	90617	114.5
1350	54	PTEZHD-1350	90618	125.9
1400	56	PTEZHD-1500	90795	129.5
1500	60	PTEZHD-1500	90619	136.8
1600	64	PTEZHD-1600	90796	144.1
1800	72	PTEZHD-1800	90620	158.6
2000	80	PTEZHD-2000	90797	173.6
2100	84	PTEZHD-2100	90621	180.9

Product Notes:

- Simple adjustable mounting brackets ensure quick and accurate installation.
- Urethane roller cover ensures long-lasting performance.
- Works in multiple applications, yet economical. Single-direction and reversing belts. Wet or dry conditions. Belts with edge damage or wear. Belts mistracking to one or both sides.
- Easy ordering and installation. Enhanced to meet instant demands for training solutions, the PTEZ is available on a one-working-day lead time. The simple brackets and component construction also ensure a quick and easy installation.
- Uses tapered and patterned roller to activate the trainer movement. Pivot influences direction while Tilt increases the tension on the mistracked side—the result is two forces quickly moving the belt back to center.
- Works with mechanically fastened or vulcanized belts.

Replacement Parts List

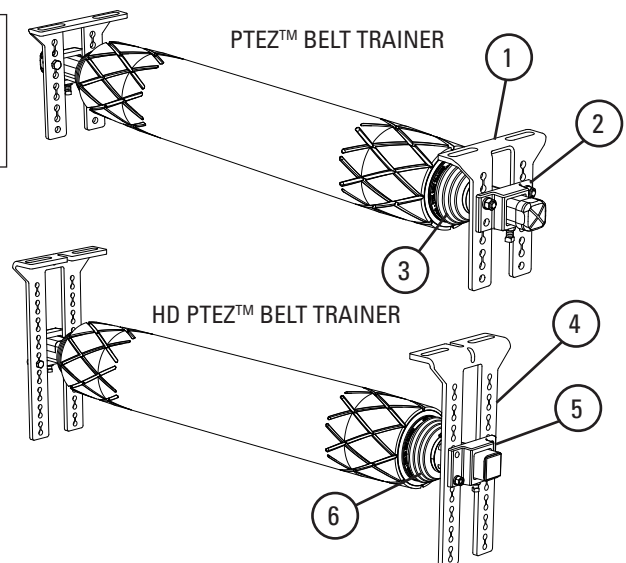
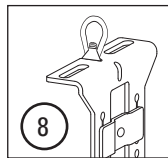
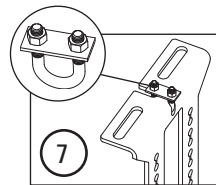

PTEZ™ Replacement Parts

REF	DESCRIPTION	ORDERING NUMBER	ITEM CODE	WT. KG.
1	PTEZ Mounting Bracket (2 ea.)	PTEZMB	90351	3.6
2	PTEZ Main Shaft Bracket (2 ea.)	PTEZPB	90352	2.7
3	PTEZ Main Shaft Dust Cover (2 ea.)	PTEZDC	90353	0.5
4	PTEZ HD Mount Bracket Kit (2 ea.)	PTEZHD-MBK	90803	8.6
5	PTEZ HD Pole Bracket Kit (2 ea.)	PTEZHD-PBK	90804	3.2
6	PTEZ HD Dust Cover Kit (2 ea.)	PTEZHD-DCK	90805	0.5
7	PTEZ HD Wire Rope Bolt Kit (2 ea.)	PTEZHD-WRBK	90806	0.5
8	PTEZ HD J Bolt Bracket Kit (2 ea.)	PTEZHD-JBBK	90807	0.9

*Bracket set for 1 roller

U.S. Patent No. 9,884,730

Specifications & Guidelines

PTEZ™
Belt Trainer

PART NUMBER	BELT WIDTH	DIM "A"	DIM "B"
90265	18"	18.75" [476mm]	36" [914mm]
90266	24"	24.75" [629mm]	42" [1067mm]
90267	30"	30.75" [781mm]	48" [1219mm]
90268	36"	36.75" [933mm]	54" [1372mm]
90269	42"	42.75" [1086mm]	60" [1524mm]
90270	48"	48.75" [1238mm]	66" [1676mm]

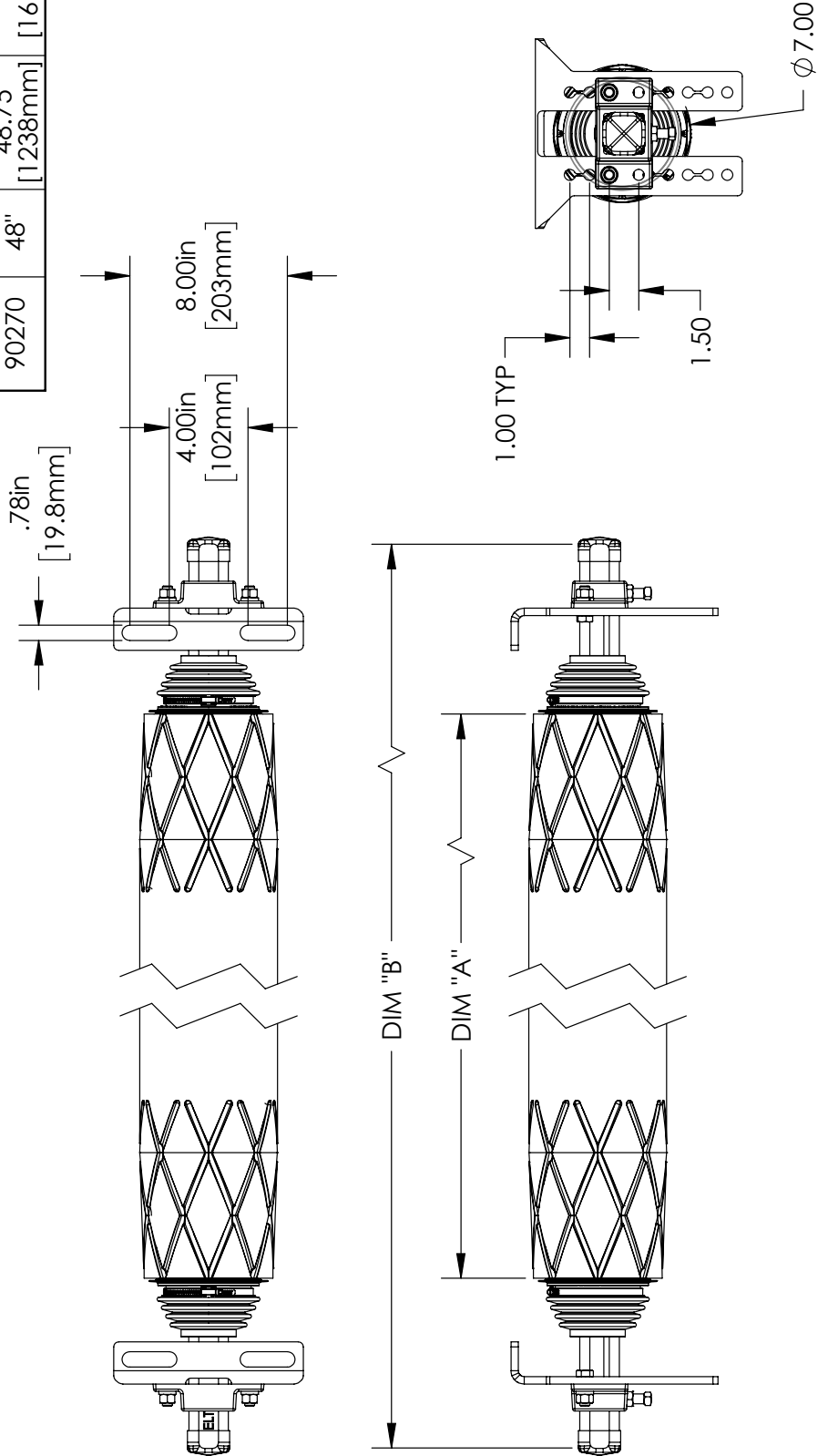

U.S. Patent No. 9,884,730

Specifications & Guidelines

HD PTEZ™
Belt Trainer

SPECIFICATIONS

BELT WIDTH (in)	BELT WIDTH (mm)	ROLL LENGTH 'A' (in)	ROLL LENGTH 'A' (mm)	SHAFT LENGTH 'B' (in)	SHAFT LENGTH 'B' (mm)	ORDERING NUMBER	ITEM CODE
42	1050	42.75	1086	60	1524	PTEZHD-42/1050	90616
48	1200	48.75	1238	66	1676	PTEZHD-48/1200	90617
54	1350	54.75	1391	72	1829	PTEZHD-54/1350	90618
56	1400	56.75	1441	74	1880	PTEZHD-56/1400	90795
60	1500	60.75	1543	78	1981	PTEZHD-60/1500	90619
64	1600	64.75	1645	82	2083	PTEZHD-64/1600	90796
72	1800	72.75	1848	90	2286	PTEZHD-72/1800	90620
80	2000	80.75	2051	98	2489	PTEZHD-80/2000	90797
84	2100	84.75	2153	102	2591	PTEZHD-84/2100	90621

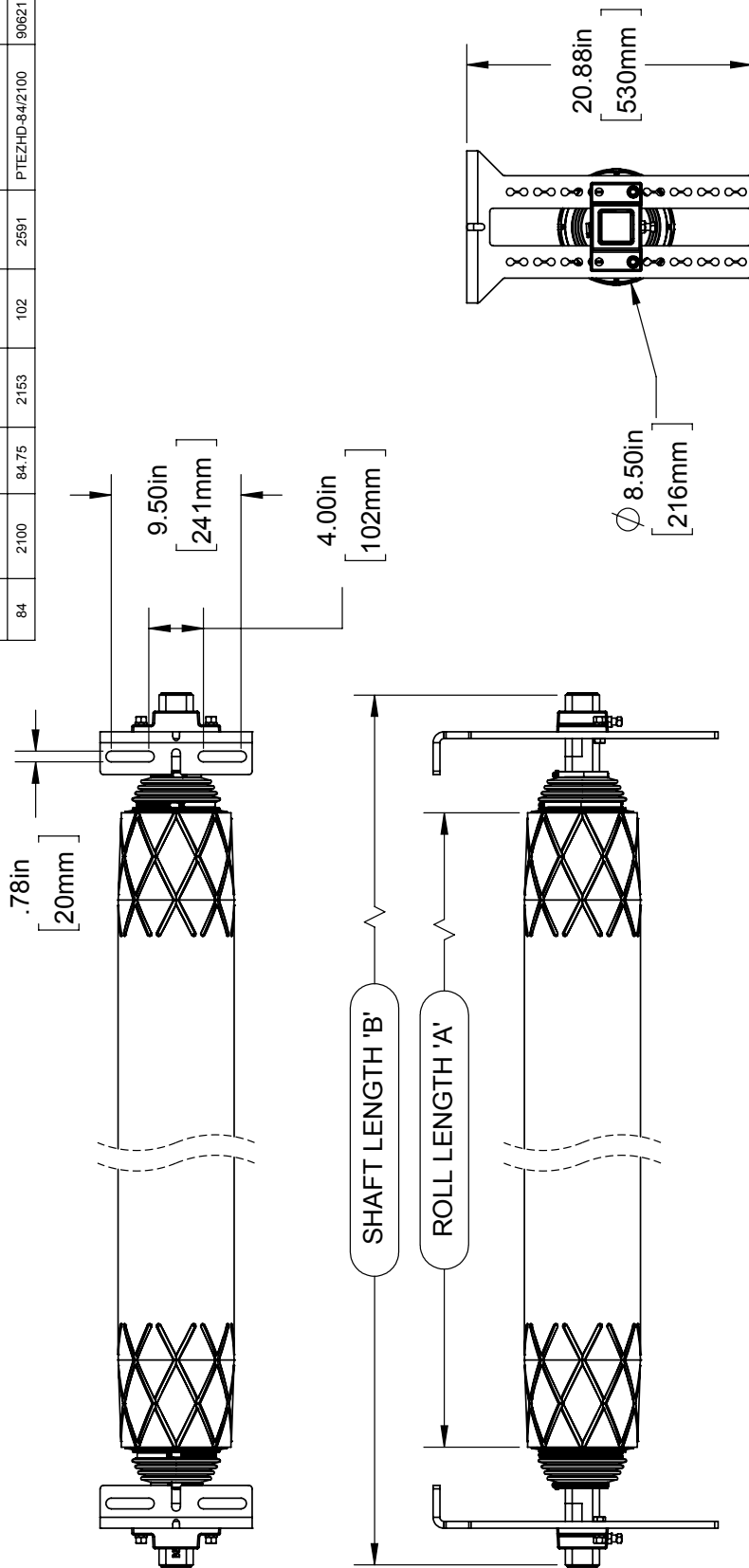

U.S. Patent No. 9,884,730

Specifications & Guidelines

HD PTEZ™ Underground Belt Trainer

SPECIFICATIONS					
BELT WIDTH (in)	ROLL LENGTH 'A' (in)	ROLL LENGTH 'A' (mm)	SHAFT LENGTH 'B' (in)	SHAFT LENGTH 'B' (mm)	ITEM CODE
42	42.75	1086	60	1524	PTEZHD-42/1050-UG 90798
48	48.75	1238	66	1676	PTEZHD-48/1200-UG 90799
54	54.75	1391	72	1829	PTEZHD-54/1350-UG 90800
60	60.75	1543	78	1981	PTEZHD-60/1500-UG 90801
72	72.75	1848	90	2286	PTEZHD-72/1800-UG 90802

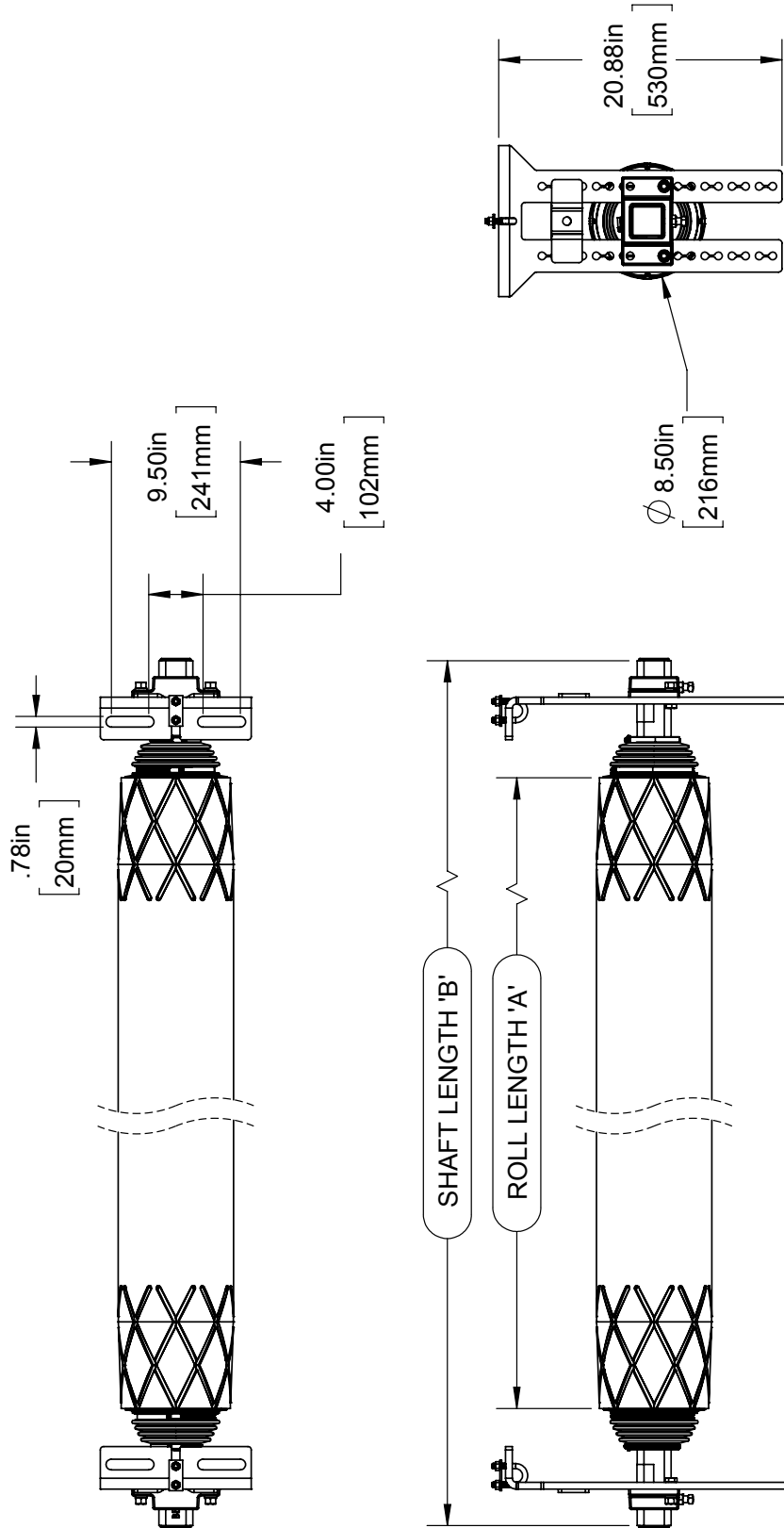

U.S. Patent No. 9,884,730

Product Ordering Information

PT Smart™
Belt Trainer



PT Smart Standard Belt Trainer (Roller Included)

PT Smart™ Belt Trainer

BELT TRAINER COMPLETE			REPLACEMENT ROLLERS	
BELT WIDTH MM	ORDERING NUMBER	ITEM CODE	ORDERING NUMBER	ITEM CODE
450	PTS-18R	77664	PTS-RR21	77680
600	PTS-24R	77665	PTS-RR27	77681
750	PTS-30R	77666	PTS-RR33	77682
900	PTS-36R	77667	PTS-RR39	77683
1050	PTS-42R	77668	PTS-RR45	77684
1200	PTS-48R	77669	PTS-RR51	77685
1350	PTS-54R	77670	PTS-RR57	77686
1500	PTS-60R	77671	PTS-RR63	77687
1800	PTS-72R	77672	PTS-RR75	77689

Lead time: 1 week

Selection Guidelines

CONVEYOR CRITERIA	PT SMART™
Top side mistracking	NO
Return side mistracking	YES
Belt mistracking to one side	EXCELLENT
Belt mistracking to both sides	EXCELLENT
Inconsistent tracking problem	EXCELLENT
Belt is cupped (heavy)	GOOD
Belt has low running tension	EXCELLENT
Belt has medium running tension	EXCELLENT
Belt has high running tension	GOOD
Approx. "upstream" effect*	6 M
Approx. "downstream" effect*	36 - 45 M

Specifications:

- Maximum Belt Speed5M/sec
- Temperature Rating-40°C to 71°C
- Belt DirectionOne way
- Available for Belt Widths450 to 1800 mm
- Application Range.....Medium-duty belts up to 1600 PIW max tension.
Belt width + 75 mm idler.
Belt thickness 25 mm maximum.

 Stock items (non-shaded) refer to (*) for specific lead time, if not specified, standard lead time applies.

 Non-stock items (shaded) please contact Flexco for dispatch options and lead times.

U.S. Patent No. 8,556,068

Replacement Parts List

PT Smart™
Belt Trainer

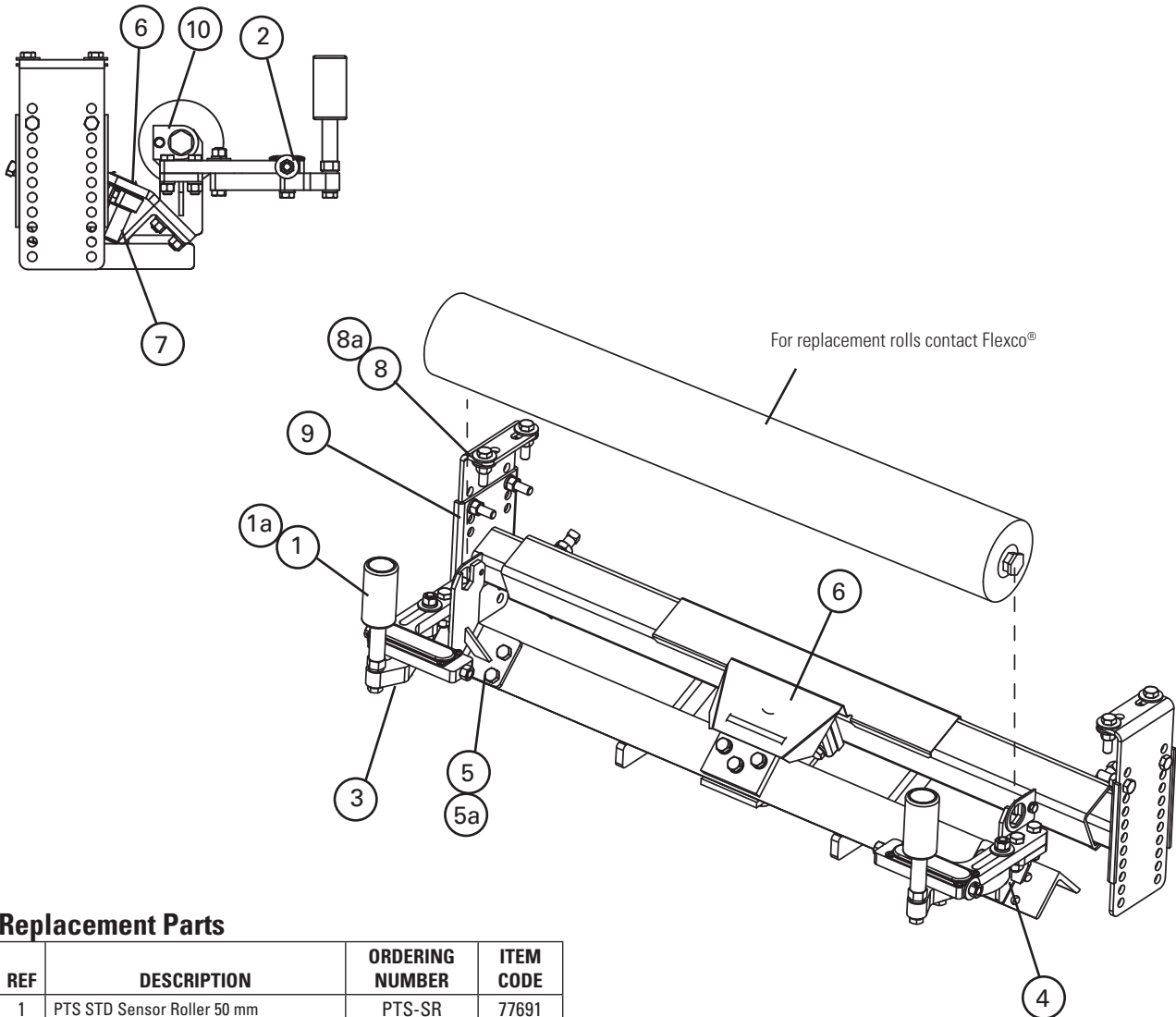

Replacement Parts

REF	DESCRIPTION	ORDERING NUMBER	ITEM CODE
1	PTS STD Sensor Roller 50 mm	PTS-SR	77691
1a	PTS HD® Sensor Roller 75 mm	PTS-HDSR	77692
2	PTS Adjusting Bolt Kit	PTS-ABK	77693
3	PTS Sensor Arm Kit (incl. 1 ea.)	PTS-SAK	77694
4	PTS RH Sensor Adjuster Assy	PTS-RHSAA	77755
	PTS LH Sensor Adjuster Assy	PTS-LHSAA	77756
5	PTS Idler Bracket Kit (incl. L & R)	PTS-IBK	77696
5a	PTS HD Idler Bracket Kit (incl. L & R)	PTS-HIBK	77697
6	PTS Pivot Shield	PTS-PS	77698
7	PTS Pivot Assy (Axle and housing)	PTS-PA	77699
8	PTS Mounting Bracket Kit	PTS-MBK	77700
8a	PTS Mounting Bracket Kit U/G	PTS-MBKUG	77701
9	PTS Extending Bracket Kit (incl. L & R)	PTS-EBK	77702
10	Roller Retainer Kit	RBPRET	73163

*Hardware included

U.S. Patent No. 8,556,068

Stock items (non-shaded) refer to (*) for specific lead time, if not specified, standard lead time applies.

Non-stock items (shaded) please contact Flexco for dispatch options and lead times.

www.flexco.com • toll-free phone: +1300-098-435

PRODUCT GUIDE

FLEXCO

PRODUCT GUIDE

165

Specifications & Guidelines

PT Smart™
Belt Trainer

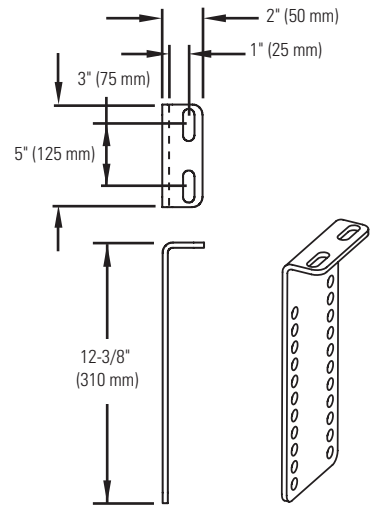
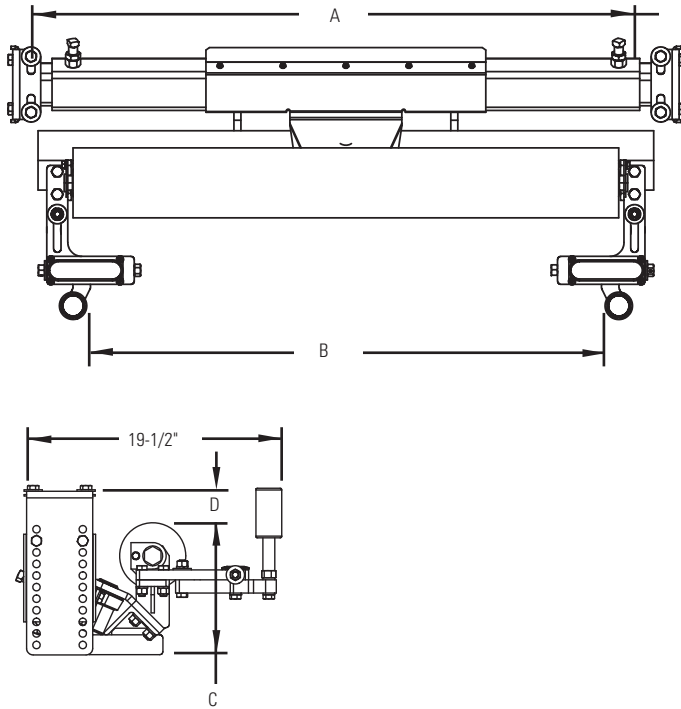

PT Smart™ Standard

BELT WIDTH mm	ITEM CODE	A	B	C	D (VERTICAL ADJUSTMENT)
450	77664	575-875mm	250-575 mm	250 mm	0-250 mm
600	77665	725-1025mm	400-725 mm		
750	77666	875-1175mm	550-875 mm		
900	77667	1025-1325mm	700-1025 mm		
1050	77668	1175-1475mm	825-1175 mm		
1200	77669	1325-1625mm	1000-1325 mm		
1350	77670	1475-1775mm	1150-1475 mm		
1500	77671	1625-1925mm	1300-1625 mm		
1800	77672	1925-2225mm	1600-1925 mm		

U.S. Patent No. 8,556,068

Product Ordering Information

PT Max™ Belt Trainer - Mild Steel

Please note that freight for all PT Max™ are ex-works.

PT Max™ Top Side

BELT WIDTH mm	ORDERING NUMBER	WT. KG.
750	PTM-750-3	130.0
900	PTM-900-3	140.0
1050	PTM-1050-3	147.0
1200	PTM-1200-3	155.0
1350	PTM-1350-3	161.0
1500	PTM-1500-3	164.0
1600	PTM-1600-3	168.0
1800	PTM-1800-3	186.0
2000	PTM-2000-3	204.0
2400	PTM-2400-3	240.0
2600	PTM-2600-3	258.0
3000	PTM-3000-3	294.0

Finish: Steel parts are sandblasted, primed, and powder coated



PT MAX TOP SIDE BELT TRAINER:
The PT MAX is delivered without rollers, but is manufactured to accommodate on site rollers.
Includes Servo Rollers.

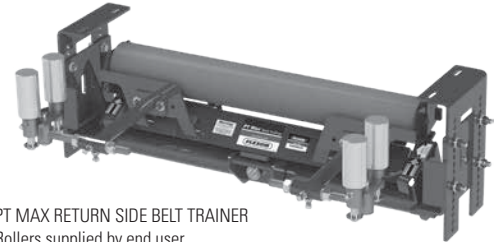

PT MAX RETURN SIDE BELT TRAINER
Rollers supplied by end user.

PT Max™ Return Side

BELT WIDTH mm	ORDERING NUMBER	WT. KG.
750	PTM-750-1	130.0
900	PTM-900-1	140.0
1050	PTM-1050-1	147.0
1200	PTM-1200-1	155.0
1350	PTM-1350-1	161.0
1500	PTM-1500-1	164.0
1600	PTM-1600-1	168.0
1800	PTM-1800-1	186.0
2000	PTM-2000-1	204.0
2400	PTM-2400-1	240.0
2600	PTM-2600-1	258.0
3000	PTM-3000-1	294.0

Finish: Steel parts are sandblasted, primed, and powder coated

PT Max™ V-Return

BELT WIDTH mm	ORDERING NUMBER	WT. KG.
750	PTM-750-2	130.0
900	PTM-900-2	140.0
1050	PTM-1050-2	147.0
1200	PTM-1200-2	155.0
1350	PTM-1350-2	161.0
1500	PTM-1500-2	164.0
1600	PTM-1600-2	168.0
1800	PTM-1800-2	186.0
2000	PTM-2000-2	204.0
2400	PTM-2400-2	240.0
2600	PTM-2600-2	258.0
3000	PTM-3000-2	294.0

Finish: Steel parts are sandblasted, primed, and powder coated

Replacement Servo Rollers

DESCRIPTION	ORDERING NUMBER	ITEM CODE	WT. KG.
SERVO 149x102	PTMSR	A0235	2.0
PTM Sensor Roller 75mmx102	MSR	74914	3.0



PT MAX V-RETURN BELT TRAINER

Product Notes:

- Please note PT Max™ no longer utilises generic item codes. Each PT Max is specifically engineered and is allocated a unique 6 digit item code upon manufacture which is also the serial number.
- FPT Max™ is custom manufactured to suit your requirements. Manufacture cannot commence without a data sheet; contact Flexco® for specification order sheet.
- For larger sizes please contact Flexco (Aust) Pty Ltd.
- Also available in other roller configurations—please contact Flexco.
- PT Max™ lead time is 4 weeks ex-Sydney from the receipt of an order and all data requirements.

U.S. Patent No. 5,358,098

Product Ordering Information

PT Max™ Belt Trainer - Stainless Steel

Please note that freight for all PT Max™ are ex-works.

PT Max™ Top Side

BELT WIDTH mm	ORDERING NUMBER	WT. KG.
750	PTM-750-3-S/S	130.0
900	PTM-900-3-S/S	140.0
1050	PTM-1050-3-S/S	147.0
1200	PTM-1200-3-S/S	155.0
1350	PTM-1350-3-S/S	161.0
1600	PTM-1600-3-S/S	168.0
1800	PTM-1800-3-S/S	186.0
2000	PTM-2000-3-S/S	204.0
2400	PTM-2400-3-S/S	240.0
2600	PTM-2600-3-S/S	258.0
3000	PTM-3000-3-S/S	294.0

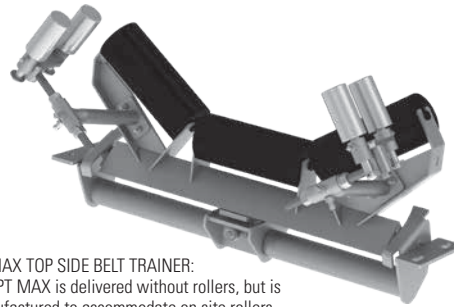

PT MAX TOP SIDE BELT TRAINER:
The PT MAX is delivered without rollers, but is manufactured to accommodate on site rollers.
Includes Servo Rollers.

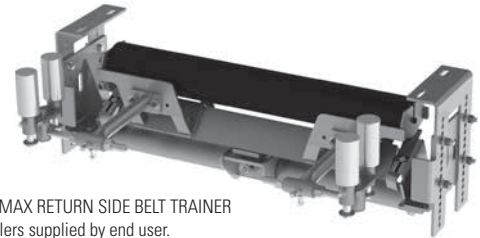

PT MAX RETURN SIDE BELT TRAINER
Rollers supplied by end user.

PT Max™ Return Side

BELT WIDTH mm	ORDERING NUMBER	WT. KG.
750	PTM-750-1-S/S	130.0
900	PTM-900-1-S/S	140.0
1050	PTM-1050-1-S/S	147.0
1200	PTM-1200-1-S/S	155.0
1350	PTM-1350-1-S/S	161.0
1600	PTM-1600-1-S/S	168.0
1800	PTM-1800-1-S/S	186.0
2000	PTM-2000-1-S/S	204.0
2400	PTM-2400-1-S/S	240.0
2600	PTM-2600-1-S/S	258.0
3000	PTM-3000-1-S/S	294.0

PT Max™ V-Return

BELT WIDTH mm	ORDERING NUMBER	WT. KG.
750	PTM-750-2-S/S	130.0
900	PTM-900-2-S/S	140.0
1050	PTM-1050-2-S/S	147.0
1200	PTM-1200-2-S/S	155.0
1350	PTM-1350-2-S/S	161.0
1600	PTM-1600-2-S/S	168.0
1800	PTM-1800-2-S/S	186.0
2000	PTM-2000-2-S/S	204.0
2400	PTM-2400-2-S/S	240.0
2600	PTM-2600-2-S/S	258.0
3000	PTM-3000-2-S/S	294.0

Replacement Servo Rollers

DESCRIPTION	ORDERING NUMBER	ITEM CODE	WT. KG.
PTM Sensor Roller 75mmx102	MSR2-S/S	79378	3.0

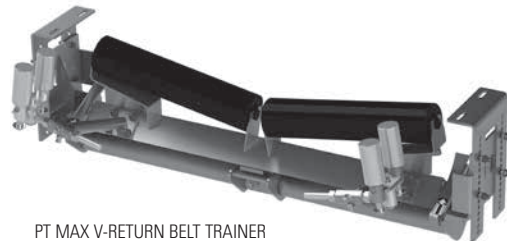

PT MAX V-RETURN BELT TRAINER

Product Notes:

- Please note PT Max™ no longer utilises generic item codes. Each PT Max is specifically engineered and is allocated a unique 6 digit item code upon manufacture which is also the serial number.
- PT Max™ is custom manufactured to suit your requirements. Manufacture cannot commence without a data sheet; contact Flexco® for specification order sheet.
- Stainless Steel PT Max™ is made from 304 Stainless Steel as standard, please specify specific requirements in the data sheet.
- For larger sizes please contact Flexco (Aust) Pty Ltd.
- Please note that PT Max™ freight terms are ex-works Sydney.
- Also available in other roller configurations—please contact Flexco.

Replacement Parts List

PT Max™
Belt Trainer

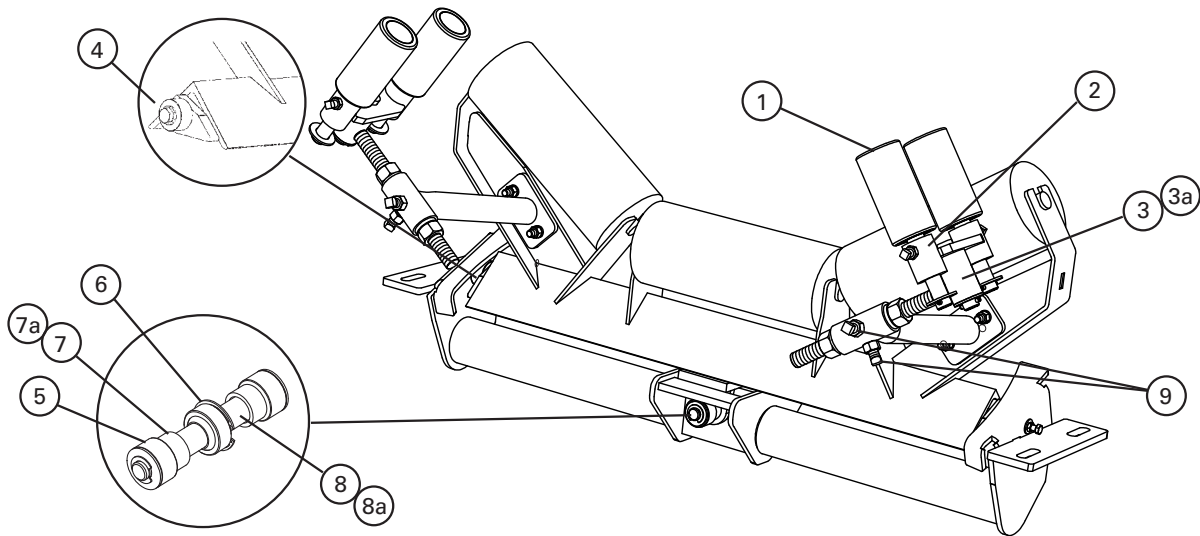

Replacement Parts

REF	DESCRIPTION	BELT WIDTH (mm)	MILD STEEL		STAINLESS STEEL	
			ORDERING NUMBER	ITEM CODE	ORDERING NUMBER	ITEM CODE
1	Sensor Roller* (3" solid roller) (1 ea.)	750-2100	MSR	74914	MSR-S/S	64924
2	Swivel Mount Kit*	750-2100	PMSMK	74916	PMSMK-S/S	64925
3	Adjusting Arm Kit*	750-1500	MAK	74918	MAK-S/S	64926
3a	HD Adjusting Arm Kit*	1350-2100	MAKHD	74919	MAKHD	74919
4	Outer Roller Kit* (incl. 2 rollers, roller thimbles and bolts, nuts and washers)	750-2100	MORK	74921	MORK	74921
5	Center Roller Kit* (incl. 2 rollers, 2 washers, and 2 cotter pins)	750-2100	MCRK	74923	MCRK	74923
6	Center Bearing*	750-2100	MCB	74925	MCB	74925
7	Center Shaft Spacer Kit (incl. 2 spacers)	750-1500	MCSK	74927	MCSK	74927
7a	HD Center Shaft Spacer Kit (incl. 2 spacers)	1350-2100	MCSKHD	74928	MCSKHD	74928
8	Center Shaft	750-1500	MCS	74930	MCS	74930
8a	HD Center Shaft	1350-2100	MCSHD	74931	MCSHD	74931
9	Frame Arm Set Screw Kit (incl. 2 setscrews and 2 jam nuts)	750-3000	MFASK	75531	MFASK	75531
-	Center Bearing Kit (incl. 1 ea. items 5, 6, 7, 8)	750-1500	MCBK	76025	MCBK	76025
-	HD Center Bearing Kit (incl. 1 ea. items 5, 6, 7a, 8a)	1350-2100	MCBKHD	76026	MCBKHD	76026

Lead time: 3 weeks

 Stock items (non-shaded) refer to (*) for specific lead time, if not specified, standard lead time applies.

 Non-stock items (shaded) please contact Flexco for dispatch options and lead times.

Product Ordering Information

RMC1 Skirt Clamps

Flex-Lok™ Skirt Clamp-Mild Steel

- One Standard Skirt Clamp includes one 2 M mounting channel, 4 clamp plates, 4 clamp pins and one 2 M restraining bar.
- One Mini Skirt Clamp includes one 2 M mounting channel, 3 clamp plates, 3 clamp pins and one 2 M restraining bar.
- Skirt board and rubber not included.

DESCRIPTION	ORDERING NUMBER	ITEM CODE	WT. KG.
Flex-Lok™ Skirt Clamp Complete	FLSC2000	71053	18.0
Mini Flex-Lok™ Skirt Clamp Complete	FLSCM2000	71148	15.0
REPLACEMENT PARTS			
Toggle Pin	FLSC-TP	71056	1.0
Clamp Plate	FLSC-CP	71057	1.0
Mini Clamp Plate	FLSCM-CP	71140	1.0
Clamp Bar-2000 mm	FLSC2000-CB	71061	5.0
Mounting Channel-2000 mm	FLSC2000-MC	71059	3.0

Finish: Clamp plates and clamp bars are powder coated steel. Mounting channel is powder coated. Toggle pins are zinc passivated steel. Skirt rubber is not included.

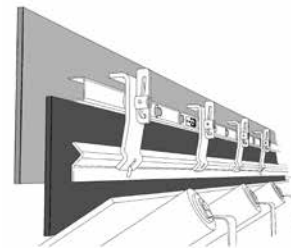

Standard

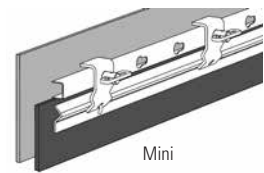

Mini

Flex-Lok™ Skirt Clamp-Stainless Steel

- One Standard Skirt Clamp includes one 2 M mounting channel, 4 clamp plates, 4 clamp pins and one 2 M restraining bar.
- One Mini Skirt Clamp includes one 2 M mounting channel, 3 clamp plates, 3 clamp pins and one 2 M restraining bar.
- Skirt board and rubber not included.

DESCRIPTION	ORDERING NUMBER	ITEM CODE	WT. KG.
Flex-Lok™ Skirt Clamp Complete	FLSC2000-S/S	A1436	20.0
Mini Flex-Lok™ Skirt Clamp Complete	FLSCM2000-S/S	61471	15.0
REPLACEMENT PARTS			
Toggle Pin	FLSC-TP-S/S	A1437	1.0
Clamp Plate	FLSC-CP-S/S	A1438	1.0
Mini Clamp Plate	FLSCM-CP-S/S	A2596	1.0
Clamp Bar-2000 mm	FLSC2000-CB-S/S	A1439	5.0
Mounting Channel-2000 mm	FLSC2000-MC-S/S	A1440	3.0

All components supplied in 300 Series Stainless.

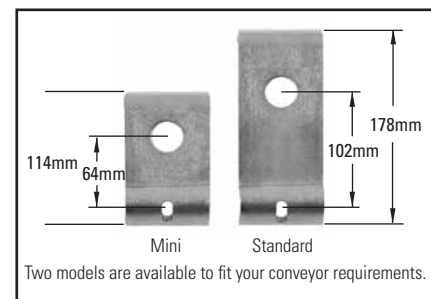

Flex-Lok™ Specifications

SKIRT RUBBER THICKNESS RANGE	
Thickness Range	8-25 mm

Product Notes:

- Solves material spillage problems in the conveyor loading zone.
- Stops material loss, eliminates safety hazards, and reduces wear on conveyor components.

 **Stock items** (non-shaded) refer to (*) for specific lead time, if not specified, standard lead time applies.

 **Non-stock items** (shaded) please contact Flexco for dispatch options and lead times.

Product Ordering Information

RMC1 Skirt Clamps

Flex-Seal™ Skirt System

DESCRIPTION	ORDERING NUMBER	ITEM CODE	WT. KG.
Flex-Seal™ Skirt System*	RMC-FS	76558	13.4
REPLACEMENT PARTS**			
Angle Plate	RMC2-AP	76559	8.6
Angle Plate Stainless Steel	RMC2-AP-S/S	A2704	8.6
PAL PAK	RMC1-PP	75832	3.0
Bolt-On PAL PAK	RMC1-BPP	76415	3.0
Clamp Bar	RMC1-CB	75817	1.8

*Flex-Seal Skirt System includes angle plate, one Bolt-On PAL PAK, and one 1.2 M clamp bar. Skirt board and rubber not included. Skirt rubber thickness range: 8 mm to 19 mm

**Replacement parts include two Bolt-On clamp pins and two clamp plates.

Flex-Seal™ Specifications

SKIRT RUBBER THICKNESS RANGE	
Width Required	150 mm
Thickness Range	8-19 mm



Bolt-On PAL PAK

Product Ordering Information

Dual Seal Polyurethane Skirting

Dual Seal Polyurethane Skirting

Height		Thickness		Length		CHAMFER	ORDERING NUMBER	ITEM CODE	WT. KG.
mm	in	mm	in	m	ft				
150	6	12	1/2	7.6	25	35°	SKPU-DUAL-6X1/2X25	91400	21.3
150	6	20	3/4				SKPU-DUAL-6X3/4X25	91401	30.8
200	8	12	1/2				SKPU-DUAL-8X1/2X25	91402	27.4
200	8	20	3/4				SKPU-DUAL-8X3/4X25	91403	40.0
150	6	12	1/2	15.2	50		SKPU-DUAL-6X1/2X50	91404	42.6
150	6	20	3/4				SKPU-DUAL-6X3/4X50	91405	61.5
200	8	12	1/2				SKPU-DUAL-8X1/2X50	91406	54.9
200	8	20	3/4				SKPU-DUAL-8X3/4X50	91407	79.9

Lead time: 1 working day

Shaded items are made to order; please contact Flexco for availability

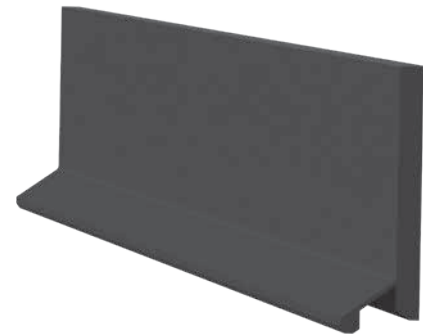

Product Notes:

- Secondary seal provides a floating contact area behind the main slab to prevent spillage.
- Polyurethane skirting offers a more wear-resistant material than typical rubber, often providing as much as 3-4 times the wear life in similar applications. The lower coefficient of friction reduces strain on the system.
- Works with Flexco series of skirt clamps that offer simple serviceability: RMC1/PAL-Pak, Flex-Lok™, and Flex-Seal™.
- Uses soft durometer (65A) polyurethane with exceptional tear resistance to ensure a good seal and long belt life.
- 7.6m (25') roll size ensures easy transportation, while the 35° chamfer eliminates the typical skirting break-in period.
- Suitable for most applications: single direction or reversing belts, wet or dry conditions, old or new belts, vulcanized or mechanically-spliced systems.
- Rated for temperatures from -30°C to 82°C (-20°F to 180°F).

 **Stock items** (non-shaded) refer to (*) for specific lead time, if not specified, standard lead time applies.

 **Non-stock items** (shaded) please contact Flexco for dispatch options and lead times.

Product Ordering Information

Standard Urethane Skirting

Standard Urethane Skirting with 35° Chamfer* - 7.6 M (25')

Height		Thickness		Length		ORDERING NUMBER	ITEM CODE	WT. KG.
mm	in	mm	in	m	ft			
100	4	10	3/8	7.6	25	SKPU-4X3/8X25	91288	21.2
100	4	12	1/2	7.6	25	SKPU-4X1/2X25	91289	28.2
100	4	16	5/8	7.6	25	SKPU-4X5/8X25	91290	35.3
100	4	19	3/4	7.6	25	SKPU-4X3/4X25	91291	42.3
100	4	25	1	7.6	25	SKPU-4X1X25	91292	56.4
150	6	10	3/8	7.6	25	SKPU-6X3/8X25	91298	31.7
150	6	12	1/2	7.6	25	SKPU-6x1/2x25	90283	18.1
150	6	16	5/8	7.6	25	SKPU-6X5/8X25	91299	52.9
150	6	20	25/32	7.6	25	SKPU-6x3/4x25	90284	27.3
150	6	25	1	7.6	25	SKPU-6X1X25	91300	84.6
200	8	10	3/8	7.6	25	SKPU-8X3/8X35	91304	42.3
200	8	12	1/2	7.6	25	SKPU-6x1/2x25	90285	26.4
200	8	16	5/8	7.6	25	SKPU-8X5/8X35	91305	70.5
200	8	20	25/32	7.6	25	SKPU-8x3/4x25	90286	40.0
200	8	25	1	7.6	25	SKPU-8X1X25	91306	112.8
250	10	10	3/8	7.6	25	SKPU-10X3/8X25	91310	52.9
250	10	12	1/2	7.6	25	SKPU-10X1/2X25	91311	70.5
250	10	16	5/8	7.6	25	SKPU-10X5/8X25	91312	88.1
250	10	19	3/4	7.6	25	SKPU-10X3/4X25	91313	105.8
250	10	25	1	7.6	25	SKPU-10X1X25	91314	141.0
300	12	10	3/8	7.6	25	SKPU-12X3/8X25	91320	63.5
300	12	12	1/2	7.6	25	SKPU-12X1/2X25	91321	84.6
300	12	16	5/8	7.6	25	SKPU-12X5/8X25	91322	105.8
300	12	19	3/4	7.6	25	SKPU-12X3/4X25	91323	126.9
300	12	25	1	7.6	25	SKPU-12X1X35	91234	169.2

Standard Urethane Skirting with 35° Chamfer* - 15.2 M (50')

Height		Thickness		Length		ORDERING NUMBER	ITEM CODE	WT. KG.
mm	in	mm	in	m	ft			
100	4	10	3/8	15.2	50	SKPU-4X3/8X50	91293	42.3
100	4	12	1/2	15.2	50	SKPU-4X1/2X50	91294	56.4
100	4	16	5/8	15.2	50	SKPU-4X5/8X50	91295	70.5
100	4	19	3/4	15.2	50	SKPU-4X3/4X50	91296	84.6
100	4	25	1	15.2	50	SKPU-4X1X50	91297	112.8
150	6	10	3/8	15.2	50	SKPU-6X3/8X50	91301	63.5
150	6	12	1/2	15.2	50	SKPU-6X1/2X50	91222	84.6
150	6	16	5/8	15.2	50	SKPU-6X5/8X50	91302	105.8
150	6	19	3/4	15.2	50	SKPU-6X3/4X50	91223	126.9
150	6	25	1	15.2	50	SKPU-6X1X50	91303	169.2
200	8	10	3/8	15.2	50	SKPU-8X3/8X50	91307	84.6
200	8	12	1/2	15.2	50	SKPU-8X1X50	91224	112.8
200	8	16	5/8	15.2	50	SKPU-8X5/8X50	91308	141.0
200	8	19	3/4	15.2	50	SKPU-8X3/4X50	91225	169.2
200	8	25	1	15.2	50	SKPU-8X1X50	91309	225.6
250	10	10	3/8	15.2	50	SKPU-10X3/8X50	91315	105.8
250	10	12	1/2	15.2	50	SKPU-10X1/2X50	91316	141.0
250	10	16	5/8	15.2	50	SKPU-10X5/8X50	91317	176.3
250	10	19	3/4	15.2	50	SKPU-10X3/4X50	91318	211.5
250	10	25	1	15.2	50	SKPU-10X1X50	91319	282.0
300	12	10	3/8	15.2	50	SKPU-12X3/8X50	91325	126.9
300	12	12	1/2	15.2	50	SKPU-12X1/2X50	91326	169.2
300	12	16	5/8	15.2	50	SKPUT-12X5/8X50	91327	211.5
300	12	19	3/4	15.2	50	SKPU-12X3/4/50	91328	253.8
300	12	25	1	15.2	50	SKPU-12X1X50	91329	338.4

*Please contact Flexco for pricing and availability



Product Notes:

- Urethane skirting offers a more wear-resistant material than typical rubber, often providing as much as 3-4 times the wear life in similar applications. The lower coefficient of friction reduces strain on the system.
- Works with Flexco series of skirt clamps that offer simple serviceability: RMC1/PAL-Pak, Flex-Lok, and Flex-Seal.
- Uses soft durometer (65A) urethane with exceptional tear resistance to ensure a good seal and long belt life.
- 7.6M (25') roll size ensures easy transportation, while the 35° chamfer eliminates the typical skirting break-in period.
- Suitable for most applications: single direction or reversing belts, wet or dry conditions, old or new belts, vulcanised or mechanically-spliced systems.
- Rated for temperatures from -30°C to 82°C (-20°F to 180°F)

 Stock items (non-shaded) refer to (*) for specific lead time, if not specified, standard lead time applies.

 Non-stock items (shaded) please contact Flexco for dispatch options and lead times.

Product Ordering Information

Enclosed Skirt System

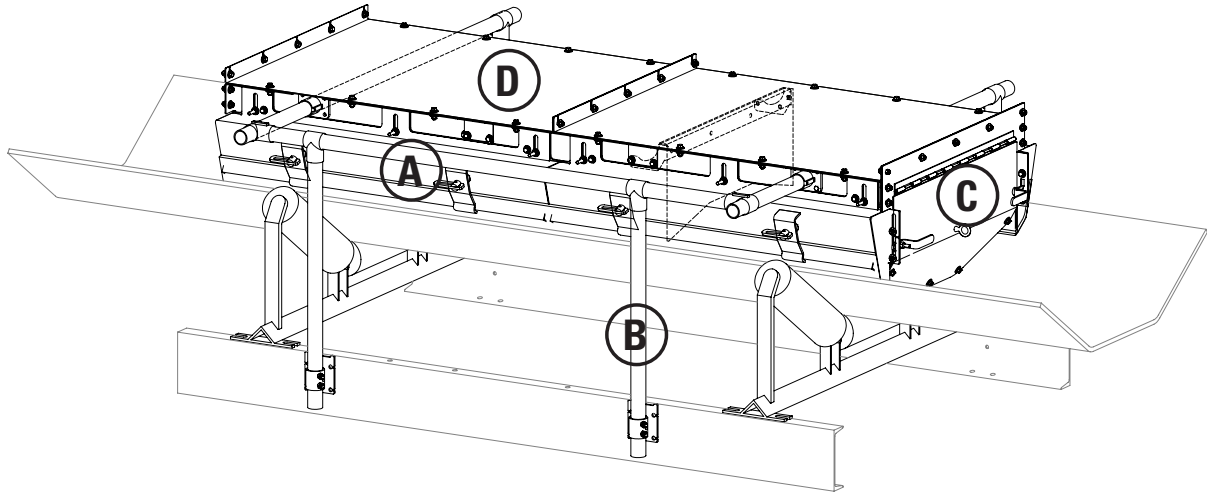

COMPONENTS

- | | |
|---|--|
| A. SKIRT BOARD – required
Available in 1200 or 2400 mm sections | C. END PLATE – optional
For belt widths 600 - 2400 mm |
| B. SUPPORT LEGS – required
For belt widths 600 - 2400 mm
Sold as two legs with a cross bar support | D. COVER PLATE – optional
Available in 1200 mm sections
For belt widths 600 - 2400 mm |

PRODUCT/ORDERING NOTES

- Maximum span between support legs is 2400mm (or 2.4M) and they are to be attached to the conveyor stringer or truss
- Skirting solutions do not include required skirt rubber; purchase from local Flexco distribution
- Straight skirt wall and tangential skirt wall available for different skirt rubber sealing options
- Product is built and sold to CEMA standards
- Skirt board liners are made with AR400 abrasive resistant plate steel

ORDERING EXAMPLE

For a covered 1200mm belt skirting system to cover 2.4M of conveyor, as shown above, with (2) 1200 skirt covers, (4) 1200mm tangential skirt walls, (1) rear seal, and (2) support legs the following should be ordered:

- (2) Covers, order number: SC-7-48
- (4) 48" Tangential Skirt Wall, order number: 4-X-15-4-T-1 or (2) 2400mm skirt walls, use 8-X-15-4-T-1
- (2) Support Legs, order number: LA-48
- (1) Rear Seal, order number: RS-1-15-48-35

 Stock items (non-shaded) refer to (*) for specific lead time, if not specified, standard lead time applies.

 Non-stock items (shaded) please contact Flexco for dispatch options and lead times.

Product Ordering Information

Enclosed Skirt System

Skirt Walls

Skirting sections do not include required skirt rubber; purchase from local Flexco distribution.

WALL LENGTH		STRAIGHT SKIRT WALL	
mm	in.	ORDERING NUMBER	WEIGHT KG.
1219	48	4-X-15-4-S-1	29.50
2438	96	8-X-15-4-S-1	59.00

WALL LENGTH		TANGENTIAL SKIRT WALL	
mm	in.	ORDERING NUMBER	WEIGHT KG.
1219	48	4-X-15-4-T-1	41.3
2438	96	8-X-15-4-T-1	83.0

*Tangential skirt wall option requires a properly tracked belt within CEMA recommendations.

Rear Seal

A rear seal can be used to enclose the rear of a skirting while providing access into the system.

BELT WIDTH		REAR SEAL	
mm	in.	ORDERING NUMBER	WEIGHT KG.
600	24	RS-1-15-24-35	7.7
750	30	RS-1-15-30-35	9.5
900	36	RS-1-15-36-35	11.3
1050	42	RS-1-15-42-35	13.6
1200	48	RS-1-15-48-35	15.4
1350	54	RS-1-15-54-35	17.7
1500	60	RS-1-15-60-35	20.0
1650	66	RS-1-15-66-35	21.8
1800	72	RS-1-15-72-35	24.5
2100	84	RS-1-15-84-35	30.0
2400	96	RS-1-15-96-35	35.8

* Do not use a rear seal for a reversing conveyor belt.

Skirt Cover

BELT WIDTH		1200mm SKIRT COVER	
mm	in.	ORDERING NUMBER	WEIGHT KG.
600	24	SC-7-24	4.5
750	30	SC-7-30	5.4
900	36	SC-7-36	6.4
1050	42	SC-7-42	7.3
1200	48	SC-7-48	6.2
1350	54	SC-7-54	9.1
1500	60	SC-7-60	10.0
1650	66	SC-7-66	10.7
1800	72	SC-7-72	12.2
2100	84	SC-7-84	14.1
2400	96	SC-7-96	15.9

*Skirt covers are made out of aluminum.

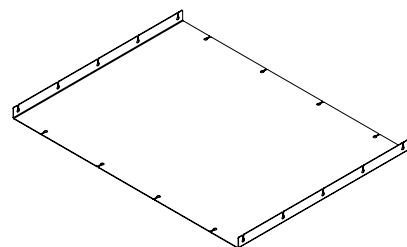
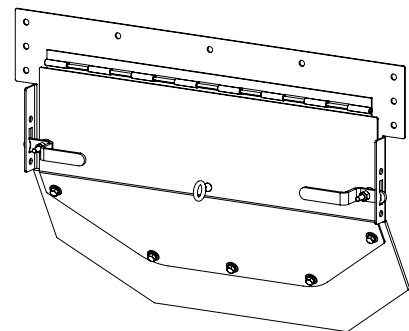
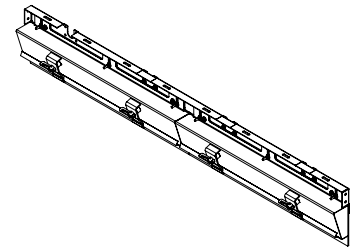
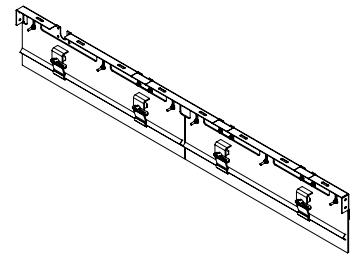

Stock items (non-shaded) refer to (*) for specific lead time, if not specified, standard lead time applies.
 Non-stock items (shaded) please contact Flexco for dispatch options and lead times.

Product Ordering Information

Enclosed Skirt System

Dust Curtain

BELT WIDTH		DUST CURTAIN (OPTIONAL)	
mm	in.	ORDERING NUMBER	WEIGHT KG.
600	24	DC-1-15-24-35	2.3
750	30	DC-1-15-30-35	2.7
900	36	DC-1-15-36-35	3.2
1050	42	DC-1-15-42-35	3.6
1200	48	DC-1-15-48-35	3.6
1350	54	DC-1-15-54-35	4.1
1500	60	DC-1-15-60-35	4.5
1650	66	DC-1-15-66-35	4.5
1800	72	DC-1-15-72-35	5.0
2100	84	DC-1-15-84-35	5.4
2400	96	DC-1-15-96-35	5.4

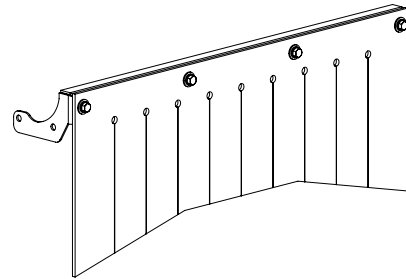

Support Leg Assembly

BELT WIDTH		SUPPORT LEG ASSEMBLY	
mm	in.	ORDERING NUMBER	WEIGHT KG.
600	24	LA-24	14.1
750	30	LA-30	14.5
900	36	LA-36	15.4
1050	42	LA-42	16.3
1200	48	LA-48	17.2
1350	54	LA-54	17.7
1500	60	LA-60	19.1
1650	66	LA-66	19.5
1800	72	LA-72	20.0
2100	84	LA-84	21.8
2400	96	LA-96	23.6

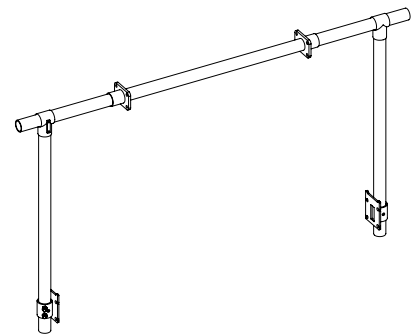



*Locate a support leg at a maximum every 2400mm (or 2.4M).
Skirt walls can accommodate support legs every 600mm (or 0.6M).

Cross Brace Spanner

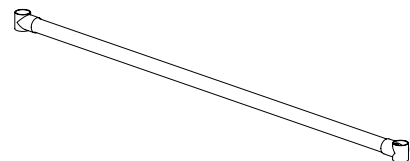
SPANNER LEG		CROSS BRACE SPANNER (OPTIONAL)	
mm	in.	ORDERING NUMBER	WEIGHT KG.
609	24	SP-24	2.7
1219	48	SP-48	5.0
1829	72	SP-72	7.3
2438	96	SP-96	10.0



*Cross brace spanner can be used to connect between cross braces to locate the vertical section of the support leg assembly anywhere along the cross brace spanner. Support legs need to be located at a maximum of every 2400mm (or 2.4M).

 **Stock items** (non-shaded) refer to (*) for specific lead time, if not specified, standard lead time applies.
 **Non-stock items** (shaded) please contact Flexco for dispatch options and lead times.

Product Ordering Information

Flexco® Belt Maintenance Tools Belt Lifters & Clamps

Flex-Lifter™ Conveyor Belt Lifter

Easy and safe way to lift tensioned belts so mechanical splicing or other maintenance work can be done.

DESCRIPTION	ORDERING NUMBER	ITEM CODE	WT. KG.
Medium Flex-Lifter 900 - 1500 mm	FLM	76979	27.3
Large Flex-Lifter 1200 - 1800 mm	FLL	76980	33.6
XL Flex-Lifter 1800 - 2400 mm	FLXL	76983	68.5
REPLACEMENT PARTS			
Extension Leg - Medium	FLEL-M	76472	1.4
Extension Leg - Large	FLEL-L	76473	1.7
Extension Leg - XL (includes 2 ext. legs)	FLELK-XL	76986	5.9
Extension Leg Pin (with lanyard)	FLELP	76474	0.1
Trough Wing - Medium (with brace)	FLTW-M	76476	0.6
Trough Wing - Large (with brace)	FLTW-L	76477	0.7
Trough Wing - XL (with brace)	FLTW-XL	76985	2.0
Retainer Pin Pack (includes 4 pins)	FLRP	76478	0.5
Retainer Clip Pack (includes 4 clips)	FLCP	76479	0.1
M-L Shear Pin Kit	FL-PKIT-ML	77250	0.1
XL Shear Pin Kit	FL-PKIT-XL	77251	0.2
Return Lift Bar - Medium	FLRLB-M	76482	8.4
Return Lift Bar - Large	FLRLB-L	76481	18.2
V-Return Lift Bar - XL	FLVRL-XL	76984	28.6
Flex-Trolley	FLCK	77729	N/A

Return lift bars included with medium and large models. Sold separately with XL models.

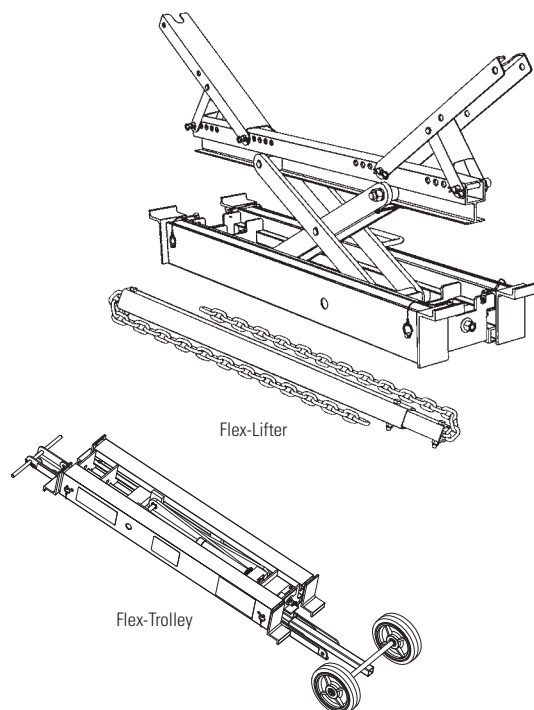

Aluminum Content Flex-Lifter

ALUMINUM ALLOY TYPE	PERCENT	
	MG-MAGNESIUM	TI-TITANIUM
4043	0.05%	0.2%
5356	5.5%	0.2%
6005	0.6%	0.1%
6061	1.0%	0.0%
6063	0.7%	0.0%
7075	2.5%	0.0%

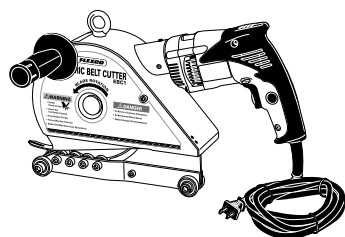

Electric Belt Cutter

Cutting Capacity

BELT TYPE	EBC-1	EBC-2
Rubber	Up to 25 mm	Up to 50 mm
PVC	Up to 630 EP	Up to 2000 EP

Electric Belt Cutter

DESCRIPTION	ORDERING NUMBER	ITEM CODE	WT. KG.
Electric Cutter Complete - 25 mm	EBC-1	30001	9.0
Electric Cutter Complete - 50 mm	EBC-2	30002	10.0
Cordless Electric Cutter Complete - 25 mm	CEBC-1	30018	9.0
Cordless Electric Cutter Complete - 50 mm	CEBC-2	30019	10.0
REPLACEMENT PARTS			
Replacement blade for EBC-1	EBC-1-B	30003	1.0
Replacement blade for EBC-2	EBC-2-B	30004	1.0
Retrofit Rail Kit for EBC1/CEBC1/PBC1	EBC1-RK	30033	0.6
Retrofit Rail Kit for EBC2/CEBC2/PBC2	EBC2-RK	30034	0.8

Pneumatic Belt Cutter

DESCRIPTION	ORDERING NUMBER	ITEM CODE	WT. KG.
Pneumatic Cutter Complete - 25 mm	PBC-1	61356	12.5
Pneumatic Cutter Complete - 50 mm	PBC-2	61357	13.5
REPLACEMENT PARTS			
Filter Set	PBC-FR	61358	2.0

Stock items (non-shaded) refer to (*) for specific lead time, if not specified, standard lead time applies.

Non-stock items (shaded) please contact Flexco for dispatch options and lead times.

U.S. Patent No. 7,810,788

INDEX By Ordering Number

Ordering Number	Item Code	Page #	Ordering Number	Item Code	Page #	Ordering Number	Item Code	Page #	Ordering Number	Item Code	Page #
66122	ULP450	125	AWTA	75907	26	BP750-S/S	76339	150	CART-60/1500-S/S	78582	54
66123	ULP600	125	AWTA	75907	32	BP800	73107	150	CART-60/1500-S/S	78582	84
66124	ULP750	125	AWTB	75905	26	BP800-1050-PL	73111	151	CART-60/1500-S/S	78582	86
66125	ULP900	125	AWTB	75905	32	BP800-1050-PL-S/S	A0613	151	CART-60/1500-S/S	78582	91
66126	ULP1050	125	AWTCB	75908	26	BP800-1050MF	73153	151	CART-60/1500-S/S	78582	93
66127	ULP1200	125	AWTCB	75908	32	BP800-1050MF-S/S			CART-60/1500-S/S	78582	98
66128	ULP1350	125	AWTHK	75909	26	MAIN FRAME	A0612	151	CART-60/1500-S/S	78582	100
66129	ULP1500	125	AWTHK	75909	32	BP800-B	74057	151	CART-60/1500-S/S	78582	105
66130	ULP1650	125	AWTMB	75906	26	BP800-S/S	76340	150	CART-60/1500-S/S	78582	106
67057	ULP1800	125	AWTMB	75906	32	BP900	73108	150	CART-72/1800-S/S	78583	48
67058	ULP2400	125	AWTNCB	76069	26	BP900-B	73779	151	CART-72/1800-S/S	78583	54
67084	ULP2000	125	AWTNCB	76069	32	BP900-S/S	76341	150	CART-72/1800-S/S	78583	84
67085	ULP2200	125	BP-LA	73127	151	C-PSTA	81045	112	CART-72/1800-S/S	78583	86
67086	ULP2600	125	BP-LA-S/S	A0614	151	CART-24/600-S/S	78576	48	CART-72/1800-S/S	78583	91
67087	ULP2800	125	BP-MB	73123	151	CART-24/600-S/S	78576	54	CART-72/1800-S/S	78583	93
67088	ULP3000	125	BP-MB-S/S	A0615	151	CART-24/600-S/S	78576	84	CART-72/1800-S/S	78583	98
4-X-15-4-S-1		174	BP-SC	73125	151	CART-24/600-S/S	78576	86	CART-72/1800-S/S	78583	100
4-X-15-4-T-1		174	BP-SC-S/S	A0616	151	CART-24/600-S/S	78576	91	CART-72/1800-S/S	78583	105
70A	61003	66	BP-TB	73138	151	CART-24/600-S/S	78576	93	CART-72/1800-S/S	78583	106
70A	61003	85	BP-TL	73141	151	CART-24/600-S/S	78576	98	CART2-114/2850-S/S	78639	49
8-X-15-4-S-1		174	BP-TL-S/S	A0617	151	CART-24/600-S/S	78576	100	CART2-114/2850-S/S	78639	55
8-X-15-4-T-1		174	BP-UB	73139	151	CART-24/600-S/S	78576	105	CART2-120/3000-S/S	78588	49
ABU	76788	112	BP1050	73110	150	CART-24/600-S/S	78576	106	CART2-120/3000-S/S	78588	55
ABU	76788	112	BP1050-B	73780	151	CART-30/750-S/S	78577	84	CART2-120/3000-S/S	78588	84
ABU	76788	113	BP1050-S/S	76342	150	CART-30/750-S/S	78577	86	CART2-120/3000-S/S	78588	86
ABU	76788	113	BP1200	73112	150	CART-30/750-S/S	78577	91	CART2-120/3000-S/S	78588	91
ACME-N	62591	43	BP1200-1400-PL	73118	151	CART-30/750-S/S	78577	93	CART2-120/3000-S/S	78588	93
ACME-N	62591	43	BP1200-1400-PL-S/S	A0621	151	CART-30/750-S/S	78577	98	CART2-120/3000-S/S	78588	98
ACME-N	62591	43	BP1200-1400MF	73154	151	CART-30/750-S/S	78577	100	CART2-120/3000-S/S	78588	100
ACME-N	62591	43	BP1200-1400MF-S/S			CART-30/750-S/S	78577	105	CART2-120/3000-S/S	78588	105
ACME-PRK	62496	43	MAIN FRAME	A0620	151	CART-30/750-S/S	78577	106	CART2-120/3000-S/S	78588	107
ACME-PRK	62496	43	BP1200-B	73781	151	CART-36/900-S/S	78578	48	CART2-126/3150-S/S	78640	49
ACME-PRK	62496	43	BP1200-S/S	76343	150	CART-36/900-S/S	78578	54	CART2-126/3150-S/S	78640	55
ACME-PRK	62496	43	BP1400	73113	150	CART-36/900-S/S	78578	84	CART2-48/1200-S/S	78580	48
AIR BAG P	62036	43	BP1400-B	73782	151	CART-36/900-S/S	78578	86	CART2-48/1200-S/S	78580	54
AIR HARK-S/S-60	62035	43	BP1400-S/S	76344	150	CART-36/900-S/S	78578	91	CART2-60/1500-S/S	78584	49
AIR HARK-S/S-73	64175	43	BP1500	73114	150	CART-36/900-S/S	78578	93	CART2-60/1500-S/S	78584	55
AIR HDMRK S/S	62034	43	BP1500-1600-PL	73119	151	CART-36/900-S/S	78578	98	CART2-60/1500-S/S	78584	84
ATV-ANGLE	62426	74	BP1500-1600-PL-S/S	A0647	151	CART-36/900-S/S	78578	100	CART2-60/1500-S/S	78584	86
ATV-ANGLE	62426	79	BP1500-1600MF	73147	151	CART-36/900-S/S	78578	105	CART2-60/1500-S/S	78584	91
ATV-ANGLE	62426	99	BP1500-1600MF-S/S			CART-36/900-S/S	78578	106	CART2-60/1500-S/S	78584	93
ATV-BAG	62036	74	MAIN FRAME	A0646	151	CART-42/1050-S/S	78579	48	CART2-60/1500-S/S	78584	98
ATV-BAG	62079	79	BP1500-B	73783	151	CART-42/1050-S/S	78579	54	CART2-60/1500-S/S	78584	100
ATV-BAG	62079	99	BP1500-S/S	76345	150	CART-42/1050-S/S	78579	84	CART2-60/1500-S/S	78584	105
ATV-MOUNT	62424	74	BP1600	73115	150	CART-42/1050-S/S	78579	86	CART2-60/1500-S/S	78584	107
ATV-MOUNT	63073	74	BP1600-B	73784	151	CART-42/1050-S/S	78579	91	CART2-66/1650-S/S	78634	49
ATV-MOUNT	62424	79	BP1600-S/S	76346	150	CART-42/1050-S/S	78579	93	CART2-66/1650-S/S	78634	55
ATV-MOUNT	63073	79	BP1800	73117	150	CART-42/1050-S/S	78579	98	CART2-72/1800-S/S	78585	49
ATV-MOUNT	62424	99	BP1800-B	73785	151	CART-42/1050-S/S	78579	100	CART2-72/1800-S/S	78585	55
ATV-MOUNT	63073	99	BP1800-PL	73121	151	CART-42/1050-S/S	78579	105	CART2-72/1800-S/S	78585	84
ATV-NIP	62037	43	BP1800-PL-S/S	A1547	151	CART-42/1050-S/S	78579	106	CART2-72/1800-S/S	78585	86
ATV-NIP	62037	74	BP1800-S/S	76347	150	CART-48/1200-S/S	78580	84	CART2-72/1800-S/S	78585	91
ATV-NIP	62037	79	BP1800MF	73148	151	CART-48/1200-S/S	78580	86	CART2-72/1800-S/S	78585	93
ATV-NIP	62037	99	BP1800MF-S/S	A1546	151	CART-48/1200-S/S	78580	91	CART2-72/1800-S/S	78585	98
ATV-SLIDE	62425	74	BP2000MF	A1996	151	CART-48/1200-S/S	78580	93	CART2-72/1800-S/S	78585	100
ATV-SLIDE	62425	79	BP450	73102	150	CART-48/1200-S/S	78580	98	CART2-72/1800-S/S	78585	105
ATV-SLIDE	62425	99	BP450-750-PL	73109	151	CART-48/1200-S/S	78580	100	CART2-72/1800-S/S	78585	107
ATVK-60	62409	74	BP450-750-PL-S/S	A0683	151	CART-48/1200-S/S	78580	105	CART2-78/1950-S/S	78635	49
ATVK-60	62409	79	BP450-750MF	73152	151	CART-48/1200-S/S	78580	106	CART2-78/1950-S/S	78635	55
ATVK-60	62409	99	BP450-750MF-S/S			CART-54/1350-S/S	78581	84	CART2-78/1950-S/S	78635	84
ATVK-73	63072	74	MAIN FRAME	A0682	151	CART-54/1350-S/S	78581	86	CART2-78/1950-S/S	78635	86
ATVK-73	63072	79	BP450-B	74055	151	CART-54/1350-S/S	78581	91	CART2-78/1950-S/S	78635	91
ATVK-73	63072	99	BP450-S/S	76337	150	CART-54/1350-S/S	78581	93	CART2-78/1950-S/S	78635	93
AWT	75904	26	BP600	73104	150	CART-54/1350-S/S	78581	98	CART2-78/1950-S/S	78635	98
AWT	75904	32	BP600-B	73777	151	CART-54/1350-S/S	78581	100	CART2-78/1950-S/S	78635	100
AWT-1S	76375	26	BP600-S/S	76338	150	CART-54/1350-S/S	78581	105	CART2-78/1950-S/S	78635	105
AWT-1S	76375	32	BP750	73106	150	CART-54/1350-S/S	78581	106	CART2-78/1950-S/S	78635	107
			BP750-B	73778	151	CART-60/1500-S/S	78582	48	CART2-84/2100-S/S	78586	49

INDEX By Ordering Number

Ordering Number	Item Code	Page #	Ordering Number	Item Code	Page #	Ordering Number	Item Code	Page #	Ordering Number	Item Code	Page #
CART2-84/2100-S/S	78586	55	CBD-ST-M-S	64784	157	CCMK	78919	66	CRB-LS40HT	77556	14
CART2-84/2100-S/S	78586	84	CBD-ST-M-S/S	61079	157	CCMK	78919	68	CRB-LS40W	77102	14
CART2-84/2100-S/S	78586	86	CBD-ST-MC	60092	157	CCMK-S/S	78921	66	CRB-LS46	77094	14
CART2-84/2100-S/S	78586	91	CBD-ST-PB	A2449	157	CCMK-S/S	78921	68	CRB-LS46HT	77557	14
CART2-84/2100-S/S	78586	93	CBD-ST-TB-S/S	A2629	157	CCMKHD	78920	66	CRB-LS46W	77103	14
CART2-84/2100-S/S	78586	98	CBD-ST-XL	61051	157	CCMKHD	78920	68	CRB-LS52	77095	14
CART2-84/2100-S/S	78586	100	CBD-ST-XL-B	64482	157	CCMKHD	78920	76	CRB-LS52HT	77558	14
CART2-84/2100-S/S	78586	105	CBD-ST-XL-FP	61114	157	CCMKHD-S/S	78922	66	CRB-LS52W	77104	14
CART2-84/2100-S/S	78586	107	CBD-ST-XL-FR-B	A1784	157	CCMKHD-S/S	78922	68	CRB-LS58	77096	14
CART2-96/2400-S/S	78587	49	CBD-ST-XL-MF	61107	157	CCMKHD-S/S	78922	76	CRB-LS58W	77105	14
CART2-96/2400-S/S	78587	55	CBD-ST-XL-MF-S/S	61110	157	CDWB24	75884	118	CRB-UHT-1000	91258	19
CART2-96/2400-S/S	78587	84	CBD-ST-XL-P	64774	157	CDWB30	75885	118	CRB-UHT-1150	91259	19
CART2-96/2400-S/S	78587	86	CBD-ST-XL-P-S/S	64625	157	CDWB36	75886	118	CRB-UHT-1300	91260	19
CART2-96/2400-S/S	78587	91	CBD-ST-XL-PS	64778	157	CDWB42	75887	118	CRB-UHT-1450	91261	19
CART2-96/2400-S/S	78587	93	CBD-ST-XL-PS-S/S	64782	157	CDWB48	75888	118	CRB-UHT-1570	91263	19
CART2-96/2400-S/S	78587	98	CBD-ST-XL-S	63024	157	CDWB54	75889	118	CRB-UHT-400	91254	19
CART2-96/2400-S/S	78587	100	CBD-ST-XL-S/S	A2138	157	CDWB60	75890	118	CRB-UHT-550	91255	19
CART2-96/2400-S/S	78587	105	CBD-ST-XXL	63747	157	CDWB72	75891	118	CRB-UHT-700	91256	19
CART2-96/2400-S/S	78587	107	CBD-ST-XXL-B	64622	157	CDWB84	76942	118	CRB-UHT-850	91257	19
CBC18	76668	123	CBD-ST-XXL-FP	63751	157	CDWB96	79062	118	CRB-W16	78472	19
CBC24	76669	123	CBD-ST-XXL-FR-B	63752	157	CEBC-1	30018	176	CRB-W22	78473	19
CBC30	76670	123	CBD-ST-XXL-MF	63749	157	CEBC-2	30019	176	CRB-W28	78474	19
CBC36	76671	123	CBD-ST-XXL-MF-S/S	63750	157	CFG-212	78838	15	CRB-W34	78475	19
CBC3R	90641	123	CBD-ST-XXL-P	64775	157	CFG-218	78839	15	CRB-W40	78476	19
CBC42	76672	123	CBD-ST-XXL-P-S/S	64626	157	CFG-224	78840	15	CRB-W46	78477	19
CBC48	76673	123	CBD-ST-XXL-PS	64779	157	CFG-230	78841	15	CRB-W52	78478	19
CBC54	76674	123	CBD-ST-XXL-PS-S/S	64783	157	CFG-236	78842	15	CRB-W58	78479	19
CBC60	76675	123	CBD-ST-XXL-S	63791	157	CFG-242	78843	15	CRB-W64	78480	19
CBCS18	90537	123	CBD-ST-XXL-S/S	63748	157	CFG-248	78844	15	CRB-W70	78481	19
CBCS24	90538	123	CBD-XL	76445	156	CFG-254	78845	15	CRB16	75629	19
CBCS30	90539	123	CBD-XL-S/S	76318	156	CFG-260	78846	15	CRB22	75630	19
CBCS36	90540	123	CBD-XXL	64787	156	CFG-272	78847	15	CRB28	75631	19
CBCS42	90541	123	CBD-XXL-S/S	63554	156	CLSFG-212	77144	10	CRB34	75632	19
CBCS48	90542	123	CBR-L	72485	156	CLSFG-218	77145	10	CRB40	75633	19
CBCS54	90543	123	CBR-M	72484	156	CLSFG-224	77146	10	CRB46	75634	19
CBCS60	90544	123	CBR-S	72483	156	CLSFG-230	77147	10	CRB52	75635	19
CBD-L	76444	156	CBR-XL	72486	156	CLSFG-236	77148	10	CRB58	75636	19
CBD-L-S/S	A1856	156	CCKHDL	79225	66	CLSFG-242	77149	10	CRB64	75775	19
CBD-M	76443	156	CCKHDL	79225	68	CLSFG-248	77150	10	CRB70	75773	19
CBD-M-S/S	A1854	156	CCKHDL	79225	76	CLSFG-254	77151	10	CRDF18	90631	123
CBD-S	76442	156	CCKHDL-S/S	79227	66	CLSFG-260	77152	10	CRDF24	90632	123
CBD-S-S/S	64178	156	CCKHDL-S/S	79227	68	CPB	76692	123	CRDF30	90633	123
CBD-ST-AA	61096	157	CCKHDL-S/S	79227	76	CRB-HT10	76593	19	CRDF36	90634	123
CBD-ST-B	64620	157	CCKHDR	79229	66	CRB-HT16	76594	19	CRDF42	90635	123
CBD-ST-BB	64310	157	CCKHDR	79229	68	CRB-HT22	76595	19	CRDF48	90636	123
CBD-ST-CS-S/S	A2215	157	CCKHDR	79229	76	CRB-HT28	76596	19	CRDF54	90637	123
CBD-ST-FR-B	61111	157	CCKHDR-S/S	79231	66	CRB-HT34	76597	19	CRDF60	90638	123
CBD-ST-HN-S/S	61100	157	CCKHDR-S/S	79231	68	CRB-HT40	76598	19	CRDLBLK-LH-S/S	A2826	87
CBD-ST-L	61050	157	CCKHDR-S/S	79231	76	CRB-HT46	76599	19	CRDLBLK-LH-S/S	A2826	94
CBD-ST-L-B	64621	157	CCKHDS	79233	66	CRB-HT52	76600	19	CRDLBLK-LH-S/S	A2826	107
CBD-ST-L-FP	61113	157	CCKHDS	79233	68	CRB-HT58	76601	19	CRDLBLK-RH-S/S	A2825	87
CBD-ST-L-FR-B	A2218	157	CCKHDS	79233	76	CRB-HT64	76602	19	CRDLBLK-RH-S/S	A2825	94
CBD-ST-L-MF	61106	157	CCKHDS-S/S	73235	66	CRB-HT70	76603	19	CRDLBLK-RH-S/S	A2825	107
CBD-ST-L-MF-S/S	61109	157	CCKHDS-S/S	73235	68	CRB-LS10	77088	14	CRHMK	62400	85
CBD-ST-L-P	64773	157	CCKHDS-S/S	73235	76	CRB-LS10W	77097	14	CRHMK	62400	92
CBD-ST-L-P-S/S	64624	157	CCKL	79224	66	CRB-LS16	77089	14	CRHMK	62400	105
CBD-ST-L-PS	64777	157	CCKL	79224	68	CRB-LS16HT	77552	14	CRHMK-S/S	62095	87
CBD-ST-L-PS-S/S	64781	157	CCKL-S/S	79226	66	CRB-LS16W	77098	14	CRHMK-S/S	62095	94
CBD-ST-L-S	64785	157	CCKL-S/S	79226	68	CRB-LS22	77090	14	CRHMK-S/S	62095	107
CBD-ST-L-S/S	61080	157	CCMKHD	78920	63	CRB-LS22HT	77553	14	CST1HDM-B	78515	99
CBD-ST-M	61077	157	CCKR	79228	66	CRB-LS22W	77099	14	CST1HDM-B-S/S	78392	101
CBD-ST-M-FP	61112	157	CCKR	79228	68	CRB-LS28	77091	14	CST1HDM-G	78516	99
CBD-ST-M-MF	61105	157	CCKR-S/S	79230	66	CRB-LS28HT	77554	14	CST1HDM-G-S/S	78393	101
CBD-ST-M-MF-S/S	61108	157	CCKR-S/S	79230	68	CRB-LS28W	77100	14	CST1HDM-S	78514	99
CBD-ST-M-P	64772	157	CCKTS	79232	66	CRB-LS34	77092	14	CST1HDM-S-S/S	78391	101
CBD-ST-M-P-S/S	64623	157	CCKTS	79232	68	CRB-LS34HT	77555	14	CST1HDM-W	78513	99
CBD-ST-M-PS-S/S	64780	157	CCKTS-S/S	79234	66	CRB-LS34W	77101	14	CST1HDM-W-S/S	78390	101
CBD-ST-M-PSS	64776	157	CCKTS-S/S	79234	68	CRB-LS40	77093	14	CSTAK	77031	99

INDEX By Ordering Number

Ordering Number	Item Code	Page #	Ordering Number	Item Code	Page #	Ordering Number	Item Code	Page #	Ordering Number	Item Code	Page #
CSTAK	77031	101	DRXH-30-435	76897	147	DRXM-36-435	76866	146	EZAI-600	82410	136
CSTBK	77037	99	DRXH-30-520	76889	147	DRXM-36-520	76858	146	EZAI-750	82411	136
CSTBK	77037	101	DRXH-30-535	76905	147	DRXM-36-535	76874	146	EZAI-900	82412	136
CSTHDMK	77871	99	DRXH-36-420	76882	147	DRXM-42-420	76851	146	EZBMK-1050	82284	141
CSTHDMK-S/S	78384	101	DRXH-36-435	76898	147	DRXM-42-435	76867	146	EZBMK-1050	82284	143
CSTHDPM	77869	99	DRXH-36-520	76890	147	DRXM-42-520	76859	146	EZBMK-1200	82285	141
CSTHDPM-S/S	78389	101	DRXH-36-535	76906	147	DRXM-42-535	76875	146	EZBMK-1200	82285	143
CT6	74535	66	DRXH-42-420	76883	147	DRXM-48-420	76852	146	EZBMK-1350	82286	141
CT6	74535	68	DRXH-42-435	76899	147	DRXM-48-435	76868	146	EZBMK-1350	82286	143
CT6	74535	69	DRXH-42-520	76891	147	DRXM-48-520	76860	146	EZBMK-1500	82287	141
CT6	74535	71	DRXH-42-535	76907	147	DRXM-48-535	76876	146	EZBMK-1500	82287	143
CT6	74535	73	DRXH-48-420	76884	147	DRXM-54-420	76853	146	EZBMK-1800	82288	141
CT6	74535	76	DRXH-48-435	76900	147	DRXM-54-435	76869	146	EZBMK-1800	82288	143
CT6	74535	78	DRXH-48-520	76892	147	DRXM-54-520	76861	146	EZBMK-600	82281	141
CT6	74535	85	DRXH-48-535	76908	147	DRXM-54-535	76877	146	EZBMK-600	82281	143
CT6	74535	87	DRXH-54-420	76885	147	DRXM-60-420	76854	146	EZBMK-750	82282	141
CT6	74535	92	DRXH-54-435	76901	147	DRXM-60-435	76870	146	EZBMK-750	82282	143
CT6	74535	94	DRXH-54-520	76893	147	DRXM-60-520	76862	146	EZBMK-900	82283	143
CT6	74535	98	DRXH-54-535	76909	147	DRXM-60-535	76878	146	EZBMK-9000	82283	141
CT6	74535	101	DRXH-60-420	76886	147	DRXM-72-420	76855	146	EZBS-1200	82361	141
CT6 (C-Tip)	74535	82	DRXH-60-435	76902	147	DRXM-72-435	76871	146	EZBS-1500	82362	141
CT6 (C-Tip)	74535	89	DRXH-60-520	76894	147	DRXM-72-520	76863	146	EZCSK-1050	82356	137
CT6 (C-Tip)	74535	96	DRXH-60-535	76910	147	DRXM-72-535	76879	146	EZCSK-1050	82356	139
CTS-B	77744	99	DRXH-72-420	76887	147	DWP72	75883	117	EZCSK-1050	82356	141
CTS-B-S/S	78387	13	DRXH-72-435	76903	147	DWP72-S/S	67409	117	EZCSK-1050	82356	143
CTS-B-S/S	78387	101	DRXH-72-520	76895	147	DWP84	76815	117	EZCSK-1200	82357	137
CTS-G	77745	99	DRXH-72-535	76911	147	DWP84-S/S	67486	117	EZCSK-1200	82357	139
CTS-G-S/S	78388	101	DRXL-24-420	76816	145	DWP96	79060	117	EZCSK-1200	82357	141
CTS-S	77743	62	DRXL-24-435	76832	145	DWP96-S/S	67487	117	EZCSK-1200	82357	143
CTS-S	77743	99	DRXL-24-520	76824	145	EBC-1	30001	176	EZCSK-1350	82358	137
CTS-S-S/S	78386	101	DRXL-24-535	76840	145	EBC-1-B	30003	176	EZCSK-1350	82358	139
CTS-W	77742	99	DRXL-30-420	76817	145	EBC-2	30002	176	EZCSK-1350	82358	141
CTS-W-S/S	78385	101	DRXL-30-435	76833	145	EBC-2-B	30004	176	EZCSK-1350	82358	143
DBK-L	76448	156	DRXL-30-520	76825	145	EBC1-RK	30033	176	EZCSK-1500	82359	137
DBK-M	76447	156	DRXL-30-535	76841	145	EBC2-RK	30034	176	EZCSK-1500	82359	139
DBK-S	76446	156	DRXL-36-420	76818	145	ESBK-ATEX	90264	18	EZCSK-1500	82359	141
DBK-XL	76449	156	DRXL-36-435	76834	145	ESBK-B	76411	17	EZCSK-1500	82359	143
DBK-XXL	62595	156	DRXL-36-520	76826	145	ESBK-B	76411	18	EZCSK-1800	82360	137
DC-1-15-24-35		175	DRXL-36-535	76842	145	ESBK-B EST	76411	18	EZCSK-1800	82360	139
DC-1-15-30-35		175	DRXL-42-420	76819	145	ESBK-PS	76410	17	EZCSK-1800	82360	141
DC-1-15-36-35		175	DRXL-42-435	76835	145	ESBK-PS	76410	18	EZCSK-1800	82360	143
DC-1-15-42-35		175	DRXL-42-520	76827	145	ESPBK	76408	17	EZCSK-600	82353	137
DC-1-15-48-35		175	DRXL-42-535	76843	145	ESPRK	76409	17	EZCSK-600	82353	139
DC-1-15-54-35		175	DRXL-48-420	76820	145	ESPSBK	76407	17	EZCSK-600	82353	141
DC-1-15-60-35		175	DRXL-48-435	76836	145	ESS-B	76413	17	EZCSK-600	82353	143
DC-1-15-66-35		175	DRXL-48-520	76828	145	ESS-S	76412	17	EZCSK-750	82354	137
DC-1-15-72-35		175	DRXL-48-535	76844	145	ESS-S	76412	112	EZCSK-750	82354	139
DC-1-15-84-35		175	DRXL-54-420	76821	145	ESS-S-S/S	79288	113	EZCSK-750	82354	141
DC-1-15-96-35		175	DRXL-54-435	76837	145	EST-B	76405	17	EZCSK-750	82354	143
DRXD-42-520	76912	148	DRXL-54-520	76829	145	EST-G-S/S	78810	18	EZCSK-900	82355	137
DRXD-42-535	76919	148	DRXL-54-535	76845	145	EST-G-S/S-UHT	66995	18	EZCSK-900	82355	139
DRXD-48-520	76913	148	DRXL-60-420	76822	145	EST-P	76403	17	EZCSK-900	82355	141
DRXD-48-535	76920	148	DRXL-60-435	76838	145	EST-P-S/S	78808	18	EZCSK-900	82355	143
DRXD-54-520	76914	148	DRXL-60-520	76830	145	EST-P-S/S-UHT	66993	18	EZIB 1050-1200L	82220	140
DRXD-54-535	76921	148	DRXL-60-535	76846	145	EST-S	76404	17	EZIB 1050-1200M	82236	142
DRXD-60-520	76915	148	DRXL-72-420	76823	145	EST-W-S/S	78809	18	EZIB 1050-1500L	82228	140
DRXD-60-535	76922	148	DRXL-72-435	76839	145	EST-W-S/S-UHT	66994	18	EZIB 1050-1500M	82244	142
DRXD-72-520	76916	148	DRXL-72-520	76831	145	ESTAK	76406	17	EZIB 1200-1200L	82221	140
DRXD-72-535	76923	148	DRXL-72-535	76847	145	ESTAK	76406	112	EZIB 1200-1200M	82237	142
DRXD-84-520	76917	148	DRXM-24-420	76848	146	ESTAK-EST	76406	43	EZIB 1200-1500L	82229	140
DRXD-84-535	76924	148	DRXM-24-435	76864	146	ESTAK-EST-S/S	78849	18	EZIB 1200-1500M	82245	142
DRXD-96-520	76918	148	DRXM-24-520	76856	146	ESTAK-EST-S/S	78849	43	EZIB 1350-1200L	82222	140
DRXD-96-535	76925	148	DRXM-24-535	76872	146	ESTAK-SS	78849	113	EZIB 1350-1200M	82238	142
DRXH-24-420	76880	147	DRXM-30-420	76849	146	EZAI-1050	82413	136	EZIB 1350-1500L	82230	140
DRXH-24-435	76896	147	DRXM-30-435	76865	146	EZAI-1200	82414	136	EZIB 1350-1500M	82246	142
DRXH-24-520	76888	147	DRXM-30-520	76857	146	EZAI-1350	82415	136	EZIB 1500-1200L	82223	140
DRXH-24-535	76904	147	DRXM-30-535	76873	146	EZAI-1500	82416	136	EZIB 1500-1200M	82239	142
DRXH-30-420	76881	147	DRXM-36-420	76850	146	EZAI-1800	82417	136	EZIB 1500-1500L	82231	140

INDEX By Ordering Number

Ordering Number	Item Code	Page #	Ordering Number	Item Code	Page #	Ordering Number	Item Code	Page #	Ordering Number	Item Code	Page #
EZIB1500-1500M	82247	142	EZP1-260-S/S	61086	15	EZRMKM	82344	139	FBP-LM-S/S	61883	155
EZIB1800-1200L	82224	140	EZP1-272	75771	15	EZSB1050-1200C	82188	136	FBP-NP	61875	155
EZIB1800-1200M	82240	142	EZP1-272-S/S	61087	15	EZSB1050-1200I	82204	138	FBP-NP-S/S	61876	155
EZIB1800-1500L	82232	140	EZP1-UHT2-1050-S/S	66960	15	EZSB1050-1500C	82196	136	FBP1050-B	61781	154
EZIB1800-1500M	82248	142	EZP1-UHT2-1200-S/S	66961	15	EZSB1050-1500I	82212	138	FBP1050-TP	61751	154
EZIB600-1200L	82217	140	EZP1-UHT2-1350-S/S	66962	15	EZSB1200-1200C	82189	136	FBP1050-TP S/S	61766	154
EZIB600-1200M	82233	142	EZP1-UHT2-1500-S/S	66963	15	EZSB1200-1200I	82205	138	FBP1200-1400-MF	61796	155
EZIB600-1500L	82225	140	EZP1-UHT2-1800-S/S	66964	15	EZSB1200-1500C	82197	136	FBP1200-1400-MF-S/S	61804	155
EZIB600-1500M	82241	142	EZP1-UHT2-450-S/S	66956	15	EZSB1200-1500I	82213	138	FBP1200-1400-PP	61891	155
EZIB750-1200L	82218	140	EZP1-UHT2-600-S/S	66957	15	EZSB1350-1200C	82190	136	FBP1200-1400-PP-S/S	61899	155
EZIB750-1200M	82234	142	EZP1-UHT2-750-S/S	66958	15	EZSB1350-1200I	82206	138	FBP1200-1400-SP	61907	155
EZIB750-1500L	82226	140	EZP1-UHT2-900-S/S	66959	15	EZSB1350-1500C	82198	136	FBP1200-1400-SP-S/S	61915	155
EZIB750-1500M	82242	142	EZP1BP	75642	17	EZSB1350-1500I	82214	138	FBP1200-B	61782	154
EZIB900-1200L	82219	140	EZP1BP	75642	17	EZSB1500-1200C	82191	136	FBP1200-TP	61752	154
EZIB900-1200M	82235	142	EZP1MPK	75637	21	EZSB1500-1200I	82207	138	FBP1200-TP S/S	61767	154
EZIB900-1500L	82227	140	EZP1MPK-S/S	78923	18	EZSB1500-1500C	82199	136	FBP1400-B	61783	154
EZIB900-1500M	82243	142	EZP1P12	75619	17	EZSB1500-1500I	82215	138	FBP1400-TP	61753	154
EZP-LS212	77127	10	EZP1P12	75619	21	EZSB1800-1200C	82192	136	FBP1400-TP S/S	61768	154
EZP-LS212-S/S	62836	10	EZP1P12-S/S	78812	18	EZSB1800-1200I	82208	138	FBP1500-1600-MF	61797	155
EZP-LS212HT	77746	10	EZP1P18	75620	17	EZSB1800-1500C	82200	136	FBP1500-1600-MF-S/S	61805	155
EZP-LS212HT-S/S	62845	10	EZP1P18	75620	21	EZSB1800-1500I	82216	138	FBP1500-1600-PP	61892	155
EZP-LS218	77128	10	EZP1P18-S/S	61182	18	EZSB600-1200C	82185	136	FBP1500-1600-PP-S/S	61900	155
EZP-LS218-S/S	62837	10	EZP1P24	75621	17	EZSB600-1200I	82201	138	FBP1500-1600-SP	61908	155
EZP-LS218HT	77747	10	EZP1P24	75621	21	EZSB600-1500C	82193	136	FBP1500-1600-SP-S/S	61916	155
EZP-LS218HT-S/S	62846	10	EZP1P24-S/S	A2988	18	EZSB600-1500I	82209	138	FBP1500-B	61784	154
EZP-LS224	77129	10	EZP1P30	75622	17	EZSB750-1200C	82186	136	FBP1500-TP	61754	154
EZP-LS224-S/S	62838	10	EZP1P30	75622	21	EZSB750-1200I	82202	138	FBP1500-TP S/S	61769	154
EZP-LS224HT	77748	10	EZP1P30-S/S	A3041	18	EZSB750-1500C	82194	136	FBP1600-B	61785	154
EZP-LS224HT-S/S	62847	10	EZP1P36	75623	17	EZSB750-1500I	82210	138	FBP1600-TP	61755	154
EZP-LS230	77130	10	EZP1P36	75623	21	EZSB900-1200C	82187	136	FBP1600-TP S/S	61770	154
EZP-LS230-S/S	62839	10	EZP1P36-S/S	A3119	18	EZSB900-1200I	82203	138	FBP1800-2000-MF	61798	155
EZP-LS230HT	77749	10	EZP1P42	75624	17	EZSB900-1500C	82195	136	FBP1800-2000-MF-S/S	61806	155
EZP-LS230HT-S/S	62848	10	EZP1P42	75624	21	EZSB900-1500I	82211	138	FBP1800-2000-PP	61893	155
EZP-LS236	77131	10	EZP1P42-S/S	61183	18	EZWPK-1050	82348	137	FBP1800-2000-PP-S/S	61901	155
EZP-LS236-S/S	62840	10	EZP1P48	75625	17	EZWPK-1050	82348	139	FBP1800-2000-SP	61909	155
EZP-LS236HT	77750	10	EZP1P48	75625	21	EZWPK-1050	82348	141	FBP1800-2000-SP-S/S	61917	155
EZP-LS236HT-S/S	62849	10	EZP1P48-S/S	61491	18	EZWPK-1050	82348	143	FBP1800-B	61786	154
EZP-LS242	77132	10	EZP1P54	75626	17	EZWPK-1200	82349	137	FBP1800-TP	61756	154
EZP-LS242-S/S	62841	10	EZP1P54	75626	21	EZWPK-1200	82349	139	FBP1800-TP S/S	61771	154
EZP-LS242HT	77751	10	EZP1P54-S/S	61184	18	EZWPK-1200	82349	141	FBP2000-B	61787	154
EZP-LS242HT-S/S	62850	10	EZP1P60	75627	17	EZWPK-1200	82349	143	FBP2000-TP	61757	154
EZP-LS248	77133	10	EZP1P60	75627	21	EZWPK-1350	82350	137	FBP2000-TP S/S	61772	154
EZP-LS248-S/S	62842	10	EZP1P60-S/S	61185	18	EZWPK-1350	82350	141	FBP2200-2400-MF	61799	155
EZP-LS248HT	77752	10	EZP1P72	75772	17	EZWPK-1350	82350	143	FBP2200-2400-MF-S/S	61807	155
EZP-LS248HT-S/S	62851	10	EZP1P72	75772	21	EZWPK-1350S	82350	139	FBP2200-2400-PP	61894	155
EZP-LS254	77134	10	EZP1P72-S/S	61186	18	EZWPK-1500	82351	137	FBP2200-2400-PP-S/S	61902	155
EZP-LS254-S/S	62843	10	EZP1PL	75641	17	EZWPK-1500	82351	139	FBP2200-2400-SP	61910	155
EZP-LS254HT	77753	10	EZP1PL	75641	21	EZWPK-1500	82351	141	FBP2200-2400-SP-S/S	61918	155
EZP-LS254HT-S/S	62852	10	EZP1PL-S/S	78848	18	EZWPK-1500	82351	143	FBP2200-B	61788	154
EZP-LS260	77135	10	EZP1T-212	78488	20	EZWPK-1800	82352	137	FBP2200-TP	61758	154
EZP-LS260-S/S	62844	10	EZP1T-218	78489	20	EZWPK-1800	82352	139	FBP2200-TP S/S	61773	154
EZP-LS260HT	77754	10	EZP1T-224	78490	20	EZWPK-1800	82352	141	FBP2400-B	61789	154
EZP-LS260HT-S/S	62853	10	EZP1T-230	78491	20	EZWPK-1800	82352	143	FBP2400-TP	61759	154
EZP1-218	75611	15	EZP1T-236	78492	20	EZWPK-600	82345	137	FBP2400-TP S/S	61774	154
EZP1-218-S/S	61081	15	EZP1T-242	78493	20	EZWPK-600	82345	139	FBP2500-2600-MF	61800	155
EZP1-224	75612	15	EZP1T-248	78494	20	EZWPK-600	82345	141	FBP2500-2600-MF-S/S	61808	155
EZP1-224-S/S	61082	15	EZP1T-254	78495	20	EZWPK-600	82345	143	FBP2500-2600-PP	61895	155
EZP1-230	75613	15	EZP1T-260	78496	20	EZWPK-750	82346	137	FBP2500-2600-PP-S/S	61903	155
EZP1-230-S/S	61017	15	EZP1T-272	78497	20	EZWPK-750	82346	139	FBP2500-2600-SP	61911	155
EZP1-236	75614	15	EZPTBT	77384	21	EZWPK-750	82346	141	FBP2500-2600-SP-S/S	61919	155
EZP1-236-S/S	61083	15	EZPTBTHD	77385	21	EZWPK-750	82346	143	FBP2500-B	61790	154
EZP1-242	75615	15	EZPTCK	78508	21	EZWPK-900	82347	137	FBP2500-TP	61760	154
EZP1-242-S/S	61016	15	EZPTCKHD	78509	21	EZWPK-900	82347	139	FBP2500-TP S/S	61775	154
EZP1-248	75616	15	EZPTMPK	78507	21	EZWPK-900	82347	141	FBP2600-B	61791	154
EZP1-248-S/S	61084	15	EZPTSK	78511	21	EZWPK-900	82347	143	FBP2600-TP	61761	154
EZP1-254	75617	15	EZPTSKHD	78512	21	FBP-FP	61888	155	FBP2600-TP S/S	61776	154
EZP1-254-S/S	61085	15	EZPTSR	78510	21	FBP-FP-S/S	61889	155	FBP900-1050-MF	61795	155
EZP1-260	75618	15	EZRMKM	82344	137	FBP-LM	61882	155	FBP900-1050-MF-S/S	61803	155

INDEX By Ordering Number

Ordering Number	Item Code	Page #	Ordering Number	Item Code	Page #	Ordering Number	Item Code	Page #	Ordering Number	Item Code	Page #
FBP900-1050-PP	61890	155	FMS-900V	79649	69	H-CARK-1600-CM-EL15	63647	51	H-CARK2-1800-CL-S/S-EL15	63611	53
FBP900-1050-PP-S/S	61898	155	FMS-900V-S/S	66108	69	H-CARK-1600-CS	62551	45	H-CARK2-1800-CLL	62612	45
FBP900-1050-SP	61906	155	FMSC2	91444	71	H-CARK-1600-CS-EL15	63646	51	H-CARK2-1800-CLL-EL15	63580	51
FBP900-1050-SP-S/S	61914	155	FMSC2	91444	71	H-CARK-1800-CL	62556	45	H-CARK2-1800-CLL-S/S	62718	47
FBP900-B	61780	154	FRPU150	61742	66	H-CARK-1800-CL-EL15	63651	51	H-CARK2-1800-CLL-S/S-EL15	63612	53
FBP900-TP	61750	154	H CARK-1000-CL-S/S	62660	47	H-CARK-1800-CM	62555	45	H-CARK2-1800-CM	62610	45
FBP900-TP S/S	61765	154	H CARK-1000-CL-S/S-EL15	63660	53	H-CARK-1800-CM-EL15	63650	51	H-CARK2-1800-CM-EL15	63578	51
FL-PKIT-ML	77250	176	H CARK-1000-CM-S/S	62659	47	H-CARK-1800-CS	62554	45	H-CARK2-1800-CM-S/S	62716	47
FL-PKIT-XL	77251	176	H CARK-1000-CM-S/S-EL15	63659	53	H-CARK-1800-CS-EL15	63649	51	H-CARK2-1800-CM-S/S-EL15	63610	53
FLL	76980	176	H CARK-1000-CS-S/S	62658	47	H-CARK-600-CL	62538	45	H-CARK2-2000-CL	62614	45
FLM	76979	176	H CARK-1000-CS-S/S-EL15	63658	53	H-CARK-600-CL-EL15	63633	51	H-CARK2-2000-CL-EL15	63582	51
FLXL	76983	176	H CARK-1200-CL-S/S	62663	47	H-CARK-600-CM	62537	45	H-CARK2-2000-CL-S/S	62720	47
FLCP	76479	176	H CARK-1200-CL-S/S-EL15	63663	53	H-CARK-600-CM-EL15	63632	51	H-CARK2-2000-CL-S/S-EL15	63614	53
FLEL-L	76473	176	H CARK-1200-CM-S/S	62662	47	H-CARK-600-CS	62536	45	H-CARK2-2000-CLL	62615	45
FLEL-M	76472	176	H CARK-1200-CM-S/S-EL15	63662	53	H-CARK-600-CS-EL15	63631	51	H-CARK2-2000-CLL-EL15	63583	51
FLELK-XL	76986	176	H CARK-1200-CS-S/S	62661	47	H-CARK-800-CL	62541	45	H-CARK2-2000-CLL-S/S	62721	47
FLELP	76474	176	H CARK-1200-CS-S/S-EL15	63661	53	H-CARK-800-CL-EL15	63636	51	H-CARK2-2000-CLL-S/S-EL15	63615	53
FLRLB-L	76482	176	H CARK-1400-CL-S/S	62666	47	H-CARK-800-CM	62540	45	H-CARK2-2000-CM	62613	45
FLRLB-M	76481	176	H CARK-1400-CL-S/S-EL15	63666	53	H-CARK-800-CM-EL15	63635	51	H-CARK2-2000-CM-EL15	63581	51
FLRP	76478	176	H CARK-1400-CM-S/S	62665	47	H-CARK-800-CS	62539	45	H-CARK2-2000-CM-S/S	62719	47
FLSC-CP	71057	170	H CARK-1400-CM-S/S-EL15	63665	53	H-CARK-800-CS-EL15	63634	51	H-CARK2-2000-CM-S/S-EL15	63613	53
FLSC-CP-S/S	A1438	170	H CARK-1400-CS-S/S	62664	47	H-CARK2-1200-CL	62601	45	H-CARK2-2200-CL	62617	45
FLSC-TP	71056	170	H CARK-1400-CS-S/S-EL15	63664	53	H-CARK2-1200-CL-EL15	63569	51	H-CARK2-2200-CL-EL15	63585	51
FLSC-TP-S/S	A1437	170	H CARK-1600-CL-S/S	62669	47	H-CARK2-1200-CL-S/S	62707	47	H-CARK2-2200-CL-S/S	62723	47
FLSC2000	71053	170	H CARK-1600-CL-S/S-EL15	63669	53	H-CARK2-1200-CL-S/S-EL15	63601	53	H-CARK2-2200-CL-S/S-EL15	63617	53
FLSC2000-CB	71061	170	H CARK-1600-CM-S/S	62668	47	H-CARK2-1200-CLL	62602	45	H-CARK2-2200-CLL	62618	45
FLSC2000-CB-S/S	A1439	170	H CARK-1600-CM-S/S-EL15	63668	53	H-CARK2-1200-CLL-EL15	63570	51	H-CARK2-2200-CLL-EL15	63586	51
FLSC2000-MC	71059	170	H CARK-1600-CS-S/S	62667	47	H-CARK2-1200-CLL-S/S	62708	47	H-CARK2-2200-CLL-S/S	62724	47
FLSC2000-MC-S/S	A1440	170	H CARK-1600-CS-S/S-EL15	63667	53	H-CARK2-1200-CLL-S/S-EL15	63602	53	H-CARK2-2200-CLL-S/S-EL15	63618	53
FLSC2000-S/S	A1436	170	H CARK-1800-CL-S/S	62672	47	H-CARK2-1200-CM	62600	45	H-CARK2-2200-CM	62616	45
FLSCM-CP	71140	170	H CARK-1800-CL-S/S-EL15	63672	53	H-CARK2-1200-CM-EL15	63568	51	H-CARK2-2200-CM-EL15	63584	51
FLSCM-CP-S/S	A2596	170	H CARK-1800-CM-S/S	62671	47	H-CARK2-1200-CM-S/S	62706	47	H-CARK2-2200-CM-S/S	62722	47
FLSCM2000	71148	170	H CARK-1800-CM-S/S-EL15	63671	53	H-CARK2-1200-CM-S/S-EL15	63600	53	H-CARK2-2200-CM-S/S-EL15	63616	53
FLSCM2000-S/S	61471	170	H CARK-1800-CS-S/S	62670	47	H-CARK2-1200-CS	62599	45	H-CARK2-2400-CL	62620	45
FLTW-L	76477	176	H CARK-1800-CS-S/S-EL15	63670	53	H-CARK2-1200-CS-EL15	63567	51	H-CARK2-2400-CL-EL15	63588	51
FLTW-M	76476	176	H CARK-600-CL-S/S	62654	47	H-CARK2-1200-CS-S/S	62705	47	H-CARK2-2400-CL-S/S	62726	47
FLTW-XL	76985	176	H CARK-600-CL-S/S-EL15	63654	53	H-CARK2-1200-CS-S/S-EL15	63599	53	H-CARK2-2400-CL-S/S-EL15	63620	53
FLVRL-XL	76984	176	H CARK-600-CM-S/S	62653	47	H-CARK2-1400-CL	62605	45	H-CARK2-2400-CLL	62621	45
FMS-1050-EL15	65663	69	H CARK-600-CM-S/S-EL15	63653	53	H-CARK2-1400-CL-EL15	63573	51	H-CARK2-2400-CLL-EL15	63589	51
FMS-1050-EL15-S/S	65673	69	H CARK-600-CS-S/S	62652	47	H-CARK2-1400-CL-S/S	62711	47	H-CARK2-2400-CLL-S/S	62727	47
FMS-1050V	79650	69	H CARK-600-CS-S/S-EL15	63652	53	H-CARK2-1400-CL-S/S-EL15	63605	53	H-CARK2-2400-CLL-S/S-EL15	63621	53
FMS-1050V-S/S	66109	69	H CARK-800-CL-S/S	62657	47	H-CARK2-1400-CLL	62606	45	H-CARK2-2400-CM	62619	45
FMS-1200-EL15	65664	69	H CARK-800-CL-S/S-EL15	63657	53	H-CARK2-1400-CLL-EL15	63574	51	H-CARK2-2400-CM-EL15	63587	51
FMS-1200-EL15-S/S	65674	69	H CARK-800-CM-S/S	62656	47	H-CARK2-1400-CLL-S/S	62712	47	H-CARK2-2400-CM-S/S	62725	47
FMS-1200V	79651	69	H CARK-800-CM-S/S-EL15	63656	53	H-CARK2-1400-CLL-S/S-EL15	63606	53	H-CARK2-2400-CM-S/S-EL15	63619	53
FMS-1200V-S/S	66110	69	H CARK-800-CS-S/S	62655	47	H-CARK2-1400-CM	62604	45	H-CARK2-2600-CL	62623	45
FMS-1350-EL15	65665	69	H CARK-800-CS-S/S-EL15	63655	53	H-CARK2-1400-CM-EL15	63572	51	H-CARK2-2600-CL-EL15	63591	51
FMS-1350-EL15-S/S	65675	69	H-CARK-1000-CL	62544	45	H-CARK2-1400-CM-S/S	62710	47	H-CARK2-2600-CL-S/S	62729	47
FMS-1350V	79652	69	H-CARK-1000-CL-EL15	63639	51	H-CARK2-1400-CM-S/S-EL15	63604	53	H-CARK2-2600-CL-S/S-EL15	63623	53
FMS-1350V-S/S	66111	69	H-CARK-1000-CM	62543	45	H-CARK2-1400-CS	62603	45	H-CARK2-2600-CLL	62624	45
FMS-1500-EL15	65666	69	H-CARK-1000-CM-EL15	63638	51	H-CARK2-1400-CS-EL15	63571	51	H-CARK2-2600-CLL-EL15	63592	51
FMS-1500-EL15-S/S	65676	69	H-CARK-1000-CS	62542	45	H-CARK2-1400-CS-S/S	62709	47	H-CARK2-2600-CLL-S/S	62730	47
FMS-1500V	79653	69	H-CARK-1000-CS-EL15	63637	51	H-CARK2-1400-CS-S/S-EL15	63603	53	H-CARK2-2600-CLL-S/S-EL15	63624	53
FMS-1500V-S/S	66112	69	H-CARK-1200-CL	62547	45	H-CARK2-1600-CL	62608	45	H-CARK2-2600-CM	62622	45
FMS-1800-EL15	65667	69	H-CARK-1200-CL-EL15	63642	51	H-CARK2-1600-CL-EL15	63576	51	H-CARK2-2600-CM-EL15	63590	51
FMS-1800-EL15-S/S	65677	69	H-CARK-1200-CM	62546	45	H-CARK2-1600-CL-S/S	62714	47	H-CARK2-2600-CM-S/S	62728	47
FMS-1800V	79654	69	H-CARK-1200-CM-EL15	63641	51	H-CARK2-1600-CL-S/S-EL15	63608	53	H-CARK2-2600-CM-S/S-EL15	63622	53
FMS-1800V-S/S	66113	69	H-CARK-1200-CS	62545	45	H-CARK2-1600-CLL	62609	45	H-CARK2-2800-CL	62626	45
FMS-600-EL15	65660	69	H-CARK-1200-CS-EL15	63640	51	H-CARK2-1600-CLL-EL15	63577	51	H-CARK2-2800-CL-EL15	63594	51
FMS-600-EL15-S/S	65670	69	H-CARK-1400-CL	62550	45	H-CARK2-1600-CLL-S/S	62715	47	H-CARK2-2800-CL-S/S	62732	47
FMS-600V	79647	69	H-CARK-1400-CL-EL15	63645	51	H-CARK2-1600-CLL-S/S-EL15	63609	53	H-CARK2-2800-CL-S/S-EL15	63626	53
FMS-600V-S/S	66106	69	H-CARK-1400-CM	62549	45	H-CARK2-1600-CM	62607	45	H-CARK2-2800-CLL	62627	45
FMS-750-EL15	65661	69	H-CARK-1400-CM-EL15	63644	51	H-CARK2-1600-CM-EL15	63575	51	H-CARK2-2800-CLL-EL15	63595	51
FMS-750-EL15-S/S	65671	69	H-CARK-1400-CS	62548	45	H-CARK2-1600-CM-S/S	62713	47	H-CARK2-2800-CLL-S/S	62733	47
FMS-750V	79648	69	H-CARK-1400-CS-EL15	63643	51	H-CARK2-1600-CM-S/S-EL15	63607	53	H-CARK2-2800-CLL-S/S-EL15	63627	53
FMS-750V-S/S	66107	69	H-CARK-1600-CL	62553	45	H-CARK2-1800-CL	62611	45	H-CARK2-2800-CM	62625	45
FMS-900-EL15	65662	69	H-CARK-1600-CL-EL15	63648	51	H-CARK2-1800-CL-EL15	63579	51	H-CARK2-2800-CM-EL15	63593	51
FMS-900-EL15-S/S	65672	69	H-CARK-1600-CM	62552	45	H-CARK2-1800-CL-S/S	62717	47	H-CARK2-2800-CM-S/S	62731	47

INDEX By Ordering Number

Ordering Number	Item Code	Page #	Ordering Number	Item Code	Page #	Ordering Number	Item Code	Page #	Ordering Number	Item Code	Page #
H-CARK2-2800-CM-S/S-EL15	63625	53	H2CP-1200	62763	55	H73CSK-G-S/S	62744	49	HBP1500-TP	A2287	152
H-CARK2-3000-CL	62629	45	H2CP-1200-S/S	62801	49	H73CSK-G-S/S	62744	54	HBP1600-B	73304	151
H-CARK2-3000-CL-EL15	63597	51	H2CP-1200-S/S	62801	55	H73CSK-G-S/S	62744	55	HBP1600-B-TP	A2321	153
H-CARK2-3000-CL-S/S	62735	47	H2CP-1400	62764	49	H73CSK-S	62745	43	HBP1600-MF-TP	A2310	153
H-CARK2-3000-CL-S/S-EL15	63629	53	H2CP-1400	62764	55	H73CSK-S	62745	49	HBP1600-MF-TP-S/S	A2509	153
H-CARK2-3000-CLL	62630	45	H2CP-1400-S/S	62802	49	H73CSK-S	62745	55	HBP1600-PL-TP	A2299	153
H-CARK2-3000-CLL-EL15	63598	51	H2CP-1400-S/S	62802	55	H73CSK-S-S/S	62746	43	HBP1600-PL-TP	A2299	155
H-CARK2-3000-CLL-S/S	62736	47	H2CP-1600	62765	49	H73CSK-S-S/S	62746	49	HBP1600-PL-TP-S/S	A2497	153
H-CARK2-3000-CLL-S/S-EL15	63630	53	H2CP-1600	62765	55	H73CSK-S-S/S	62746	55	HBP1600-PL-TP-S/S	A2497	155
H-CARK2-3000-CM	62628	45	H2CP-1600-S/S	62803	49	HARK	73069	42	HBP1600-TP	A2288	152
H-CARK2-3000-CM-EL15	63596	51	H2CP-1600-S/S	62803	55	HARK	73069	112	HBP1800-B	73306	151
H-CARK2-3000-CM-S/S	62734	47	H2CP-1800	62766	49	HARK-S/S	75423	42	HBP1800-B-TP	A2322	153
H-CARK2-3000-CM-S/S-EL15	63628	53	H2CP-1800	62766	55	HARK-S/S	77364	113	HBP1800-MF-TP	A2311	153
H-SAC-AP-1000	62454	48	H2CP-1800-S/S	62804	49	HATDMK-S/S	63861	43	HBP1800-MF-TP-S/S	A2510	153
H-SAC-AP-1000	62454	49	H2CP-1800-S/S	62804	55	HBP-LA-TP	A2330	153	HBP1800-PL-TP	A2300	153
H-SAC-AP-1000	62454	49	H2CP-2000	62767	49	HBP-LA-TP-S/S	A2515	153	HBP1800-PL-TP	A2300	155
H-SAC-AP-1000	62454	49	H2CP-2000	62767	55	HBP-MB-TP	73922	153	HBP1800-PL-TP-S/S	A2498	153
H-SAC-AP-1000	62454	49	H2CP-2000-S/S	62805	49	HBP-MB-TP	73922	155	HBP1800-PL-TP-S/S	A2498	155
H-SAC-AP-1000	62454	54	H2CP-2000-S/S	62805	55	HBP-MB-TP-S/S	A1155	153	HBP1800-TP	A2289	152
H-SAC-AP-1000	62454	55	H2CP-2400	62768	49	HBP-MB-TP-S/S	A1155	155	HBP2000-B	73307	151
H-SAC-AP-1000	62454	55	H2CP-2400	62768	55	HBP-SC-TP	74490	153	HBP2000-B-TP	A2323	153
H-SAC-AP-1000	62454	55	H2CP-2400-S/S	62806	49	HBP-SC-TP-S/S	A2189	153	HBP2000-MF-TP	A2312	153
H-SAC-AP-1000	62454	55	H2CP-2400-S/S	62806	55	HBP-TP-1050 S/S	A2475	152	HBP2000-MF-TP-S/S	A2511	153
H-SAC-AP-1200	62455	48	H2CP-2600	62769	49	HBP-TP-1200 S/S	A2476	152	HBP2000-PL-TP	A2301	153
H-SAC-AP-1200	62455	49	H2CP-2600	62769	55	HBP-TP-1400 S/S	A2477	152	HBP2000-PL-TP	A2301	155
H-SAC-AP-1200	62455	49	H2CP-2600-S/S	62807	49	HBP-TP-1500 S/S	A2478	152	HBP2000-PL-TP-S/S	A2499	153
H-SAC-AP-1200	62455	49	H2CP-2600-S/S	62807	55	HBP-TP-1600 S/S	A2479	152	HBP2000-PL-TP-S/S	A2499	155
H-SAC-AP-1200	62455	49	H2CP-2800	62770	49	HBP-TP-1800 S/S	A2480	152	HBP2000-TP	A2290	152
H-SAC-AP-1200	62455	54	H2CP-2800	62770	55	HBP-TP-2000 S/S	A2481	152	HBP2200-B	73308	151
H-SAC-AP-1200	62455	55	H2CP-2800-S/S	62808	49	HBP-TP-2200 S/S	A2482	152	HBP2200-B-TP	A2325	153
H-SAC-AP-1200	62455	55	H2CP-2800-S/S	62808	55	HBP-TP-2400 S/S	A2483	152	HBP2200-MF-TP	A2314	153
H-SAC-AP-1200	62455	55	H2CP-3000	62771	49	HBP-TP-2500 S/S	A2484	152	HBP2200-MF-TP-S/S	A2512	153
H-SAC-AP-1200	62455	55	H2CP-3000	62771	55	HBP-TP-900 S/S	A2474	152	HBP2200-PL-TP	A2303	153
H-SAC-AP-1400	62456	48	H2CP-3000-S/S	62809	49	HBP1050-B	A2237	151	HBP2200-PL-TP	A2303	155
H-SAC-AP-1400	62456	49	H2CP-3000-S/S	62809	55	HBP1050-B-TP	A2317	153	HBP2200-PL-TP-S/S	A2500	153
H-SAC-AP-1400	62456	49	H60CSK-B	62747	43	HBP1050-MF-TP	A2306	153	HBP2200-PL-TP-S/S	A2500	155
H-SAC-AP-1400	62456	49	H60CSK-B-S/S	62748	43	HBP1050-MF-TP-S/S	A2505	153	HBP2200-TP	A2291	152
H-SAC-AP-1400	62456	49	H60CSK-G	62741	43	HBP1050-PL-TP	A2295	153	HBP2400-B	73309	151
H-SAC-AP-1400	62456	54	H60CSK-G-S/S	62742	43	HBP1050-PL-TP	A2295	155	HBP2400-B-TP	A2324	153
H-SAC-AP-1400	62456	55	H73BTK	63079	48	HBP1050-PL-TP-S/S	A2493	153	HBP2400-MF-TP	A2313	153
H-SAC-AP-1400	62456	55	H73BTK	63079	49	HBP1050-PL-TP-S/S	A2493	155	HBP2400-MF-TP-S/S	A2513	153
H-SAC-AP-1400	62456	55	H73BTK	63079	54	HBP1050-TP	A2284	152	HBP2400-PL-TP	A2302	153
H-SAC-AP-1400	62456	55	H73BTK	63079	55	HBP1200-B	73301	151	HBP2400-PL-TP	A2302	155
H-SAC-AP-1600	62457	48	H73BTK-S/S	63080	48	HBP1200-B-TP	A2318	153	HBP2400-PL-TP-S/S	A2501	153
H-SAC-AP-1600	62457	49	H73BTK-S/S	63080	49	HBP1200-MF-TP	A2307	153	HBP2400-PL-TP-S/S	A2501	155
H-SAC-AP-1600	62457	54	H73BTK-S/S	63080	54	HBP1200-MF-TP-S/S	A2506	153	HBP2400-TP	A2292	152
H-SAC-AP-1600	62457	55	H73BTK-S/S	63080	55	HBP1200-PL-TP	A2296	153	HBP2500-B	73311	151
H-SAC-AP-1800	62458	48	H73CSK-B	62749	42	HBP1200-PL-TP	A2296	155	HBP2500-B-TP	A2326	153
H-SAC-AP-1800	62458	54	H73CSK-B	62749	43	HBP1200-PL-TP-S/S	A2494	153	HBP2500-MF-TP	A2315	153
H-SAC-AP-600	62452	48	H73CSK-B	62749	48	HBP1200-PL-TP-S/S	A2494	155	HBP2500-MF-TP-S/S	A2514	153
H-SAC-AP-600	62452	49	H73CSK-B	62749	49	HBP1200-PL-TP	A2285	152	HBP2500-PL-TP	A2304	153
H-SAC-AP-600	62452	49	H73CSK-B	62749	54	HBP1400-B	73302	151	HBP2500-PL-TP	A2304	155
H-SAC-AP-600	62452	49	H73CSK-B	62749	55	HBP1400-B-TP	A2319	153	HBP2500-PL-TP-S/S	A2502	153
H-SAC-AP-600	62452	54	H73CSK-B-S/S	62750	42	HBP1400-MF-TP	A2308	153	HBP2500-PL-TP-S/S	A2502	155
H-SAC-AP-600	62452	55	H73CSK-B-S/S	62750	43	HBP1400-MF-TP-S/S	A2507	153	HBP2500-TP	A2293	152
H-SAC-AP-600	62452	55	H73CSK-B-S/S	62750	48	HBP1400-PL-TP	A2297	153	HBP2600-PL-TP	A0151	155
H-SAC-AP-600	62452	55	H73CSK-B-S/S	62750	49	HBP1400-PL-TP	A2297	155	HBP2600-PL-TP-S/S	61877	155
H-SAC-AP-800	62453	48	H73CSK-B-S/S	62750	54	HBP1400-PL-TP-S/S	A2495	153	HBP750-B	A0223	151
H-SAC-AP-800	62453	49	H73CSK-B-S/S	62750	55	HBP1400-PL-TP-S/S	A2495	155	HBP900-B	A0224	151
H-SAC-AP-800	62453	49	H73CSK-G	62743	42	HBP1400-TP	A2286	152	HBP900-B-TP	A2316	153
H-SAC-AP-800	62453	49	H73CSK-G	62743	43	HBP1500-B	73303	151	HBP900-MF-TP	A2305	153
H-SAC-AP-800	62453	49	H73CSK-G	62743	48	HBP1500-B-TP	A2320	153	HBP900-MF-TP-S/S	A2504	153
H-SAC-AP-800	62453	54	H73CSK-G	62743	49	HBP1500-MF-TP	A2309	153	HBP900-PL-TP	A2294	153
H-SAC-AP-800	62453	55	H73CSK-G	62743	54	HBP1500-MF-TP-S/S	A2508	153	HBP900-PL-TP	A2294	155
H-SAC-AP-800	62453	55	H73CSK-G	62743	55	HBP1500-PL-TP	A2298	153	HBP900-PL-TP-S/S	A2492	153
H-SAC-AP-800	62453	55	H73CSK-G-S/S	62744	42	HBP1500-PL-TP	A2298	155	HBP900-PL-TP-S/S	A2492	155
H-SAC-AP-800	62453	55	H73CSK-G-S/S	62744	43	HBP1500-PL-TP-S/S	A2496	153	HBP900-TP	A2283	152
H2CP-1200	62763	49	H73CSK-G-S/S	62744	48	HBP1500-PL-TP-S/S	A2496	155	HBRK	73068	42

INDEX By Ordering Number

Ordering Number	Item Code	Page #	Ordering Number	Item Code	Page #	Ordering Number	Item Code	Page #	Ordering Number	Item Code	Page #
HBRK-S/S	75422	42	HDRGK	79236	131	HSA8CL	62507	54	HSHD-S/S	76467	42
HBRK-S/S -73	76246	43	HDRP17	63679	133	HSA8CL	62507	55	HSHD-S/S	76467	48
HBRK-S/S-60	75422	43	HDRP22	63678	133	HSA8CL-S/S	62511	46	HSHD-S/S	76467	49
HBRKX	74549	42	HDRR24	79019	131	HSA8CL-S/S	62511	48	HSHD-S/S	76467	54
HBRKX-S/S	76246	42	HDRR30	79020	131	HSA8CL-S/S	62511	49	HSHD-S/S	76467	55
HCP-1000	62753	48	HDRR36	79021	131	HSA8CL-S/S	62511	52	HSTSS	61173	42
HCP-1000	62753	54	HDRR42	79022	131	HSA8CL-S/S	62511	54	HTF212	76658	15
HCP-1000-S/S	62759	48	HDRR48	79023	131	HSA8CL-S/S	62511	55	HTF212-S/S	62826	15
HCP-1000-S/S	62759	54	HDRR54	79024	131	HSA8CLL	62508	48	HTF218	76659	15
HCP-1200	62754	48	HDRR60	79025	131	HSA8CLL	62508	49	HTF218-S/S	62827	15
HCP-1200	62754	54	HDRR72	79026	131	HSA8CLL	62508	50	HTF224	76660	15
HCP-1200-S/S	62760	48	HDRR84	79027	131	HSA8CLL	62508	54	HTF224-S/S	62828	15
HCP-1200-S/S	62760	54	HDRS72	79017	131	HSA8CLL	62508	55	HTF230	76661	15
HCP-1400	62755	48	HDRS84	79018	131	HSA8CLL-S/S	62512	46	HTF230-S/S	62829	15
HCP-1400	62755	54	HDSTCK-S/S	A2189	42	HSA8CLL-S/S	62512	48	HTF236	76662	15
HCP-1400-S/S	62761	48	HDSTKD	A2518	42	HSA8CLL-S/S	62512	49	HTF236-S/S	62830	15
HCP-1400-S/S	62761	54	HDSTKD-S/S	A2519	42	HSA8CLL-S/S	62512	52	HTF242	76663	15
HCP-1800	62756	48	HDS	74502	112	HSA8CLL-S/S	62512	54	HTF242-S/S	62831	15
HCP-1800	62756	54	HDS-S/S	75586	113	HSA8CLL-S/S	62512	55	HTF248	76664	15
HCP-1800-S/S	62762	48	HEX NUT	G1211	43	HSA8CM	62506	48	HTF248-S/S	62832	15
HCP-1800-S/S	62762	54	HEX NUT	G1211	74	HSA8CM	62506	49	HTF254	76665	15
HCP-600	62751	48	HEX NUT	G1211	79	HSA8CM	62506	50	HTF254-S/S	62833	15
HCP-600	62751	54	HEX NUT	G1211	99	HSA8CM	62506	54	HTF260	76666	15
HCP-600-S/S	62757	48	HMK	73054	42	HSA8CM	62506	55	HTF260-S/S	62834	15
HCP-600-S/S	62757	54	HMK-S/S	75424	42	HSA8CM-S/S	62510	46	HTF272	76667	15
HCP-800	62752	48	HP1050	73035	42	HSA8CM-S/S	62510	48	HTF272-S/S	62835	15
HCP-800	62752	54	HP1050-S/S	75377	42	HSA8CM-S/S	62510	49	HTTS	74141	133
HCP-800-S/S	62758	48	HP1200	73037	42	HSA8CM-S/S	62510	52	HV-1000-SAC-CL	62523	44
HCP-800-S/S	62758	54	HP1200-S/S	75378	42	HSA8CM-S/S	62510	54	HV-1000-SAC-CL-EL15	63214	50
HCSBB-60	62513	43	HP1500	73066	42	HSA8CM-S/S	62510	55	HV-1000-SAC-CL-S/S	62639	46
HCSBB-60	62513	43	HP1500-S/S	75379	42	HSA8CS	62505	48	HV-1000-SAC-CL-S/S-EL15	63235	52
HCSBB-73	62514	43	HP1600	73739	42	HSA8CS	62505	49	HV-1000-SAC-CM	62522	44
HCSBB-73	62514	43	HP1600-S/S	75380	42	HSA8CS	62505	50	HV-1000-SAC-CM-EL15	63213	50
HCSSB-B/G	62589	43	HP450	73027	42	HSA8CS	62505	54	HV-1000-SAC-CM-S/S	62638	46
HCSSB-B/G	62589	43	HP450-S/S	75373	42	HSA8CS	62505	55	HV-1000-SAC-CM-S/S-EL15	63234	52
HCSSB-B/G	62589	43	HP600	73029	42	HSA8CS-S/S	62509	46	HV-1000-SAC-CS	62521	44
HCSSB-B/G	62589	43	HP600-S/S	75374	42	HSA8CS-S/S	62509	48	HV-1000-SAC-CS-EL15	63212	50
HCSSB-S	62590	43	HP750	73031	42	HSA8CS-S/S	62509	49	HV-1000-SAC-CS-S/S	62637	46
HCSSB-S	62590	43	HP750-S/S	75375	42	HSA8CS-S/S	62509	52	HV-1000-SAC-CS-S/S-EL15	63233	52
HCSTAK	62494	43	HP900	73033	42	HSA8CS-S/S	62509	54	HV-1200-2SAC-CL	62559	44
HCSTAK-S/S	62495	43	HP900-S/S	75376	42	HSA8CS-S/S	62509	55	HV-1200-2SAC-CL-EL15	63423	50
HCSTK-60-B	62747	42	HPHD1800	74601	42	HSA8L	73063	38	HV-1200-2SAC-CL-S/S	62675	46
HCSTK-60-B-S/S	62748	42	HPHD1800-S/S	A2063	42	HSA8L	73063	40	HV-1200-2SAC-CL-S/S-EL15	63455	52
HCSTK-60-G	62741	42	HPHD2000	74547	42	HSA8L-S/S	73774	39	HV-1200-2SAC-CLL	62560	44
HCSTK-60-G-S/S	62742	42	HPHD2000-S/S	A1783	42	HSA8L-S/S	73774	41	HV-1200-2SAC-CLL-EL15	63424	50
HDARK	74550	42	HPHD2400	74548	42	HSA8LL	73064	38	HV-1200-2SAC-CLL-S/S	62676	46
HDARK	77329	112	HPHD2400-S/S	A2590	42	HSA8LL	73064	40	HV-1200-2SAC-CLL-S/S-EL15	63456	52
HDARK-S/S	76247	42	HPS8	73050	42	HSA8LL-S/S	74033	39	HV-1200-2SAC-CM	62558	44
HDARK-S/S	77331	113	HSA	73486	42	HSA8LL-S/S	74033	41	HV-1200-2SAC-CM-EL15	63422	50
HDATDMK-S/S	63862	43	HSA200	73489	38	HSA8M	73049	38	HV-1200-2SAC-CM-S/S	62674	46
HDCK	74490	42	HSA200	73489	40	HSA8M	73049	40	HV-1200-2SAC-CM-S/S-EL15	63454	52
HDMK	74551	42	HSA200	73489	42	HSA8M-S/S	73773	39	HV-1200-2SAC-CS	62557	44
HDMK-S/S	76248	42	HSA200	73489	44	HSA8M-S/S	73773	41	HV-1200-2SAC-CS-EL15	63421	50
HDMRK	74582	42	HSA200	73489	44	HSA8S	73048	38	HV-1200-2SAC-CS-S/S	62673	46
HDMRK	74582	42	HSA200	73489	44	HSA8S	73048	40	HV-1200-2SAC-CS-S/S-EL15	63453	52
HDMRK-S/S	76245	42	HSA200	73489	44	HSA8S-S/S	73772	39	HV-1200-SAC-CL	62526	44
HDMRK-S/S	76245	42	HSA200	73489	44	HSA8S-S/S	73772	41	HV-1200-SAC-CL-EL15	63217	50
HDPHSC-S/S	61001	66	HSA200	73489	48	HSA8SS	73047	38	HV-1200-SAC-CL-S/S	62642	46
HDPHSC-S/S	61001	87	HSA200	73489	49	HSA8SS	73047	40	HV-1200-SAC-CL-S/S-EL15	63238	52
HDR24	79010	131	HSA200	73489	50	HSA8SS-S/S	73771	39	HV-1200-SAC-CM	62525	44
HDR30	79011	131	HSA200	73489	54	HSA8SS-S/S	73771	41	HV-1200-SAC-CM-EL15	63216	50
HDR36	79012	131	HSA200	73489	55	HSA8SSS	75565	39	HV-1200-SAC-CM-S/S	62641	46
HDR42	79013	131	HSA200-EL15	76027	50	HSA8SSS	75565	40	HV-1200-SAC-CM-S/S-EL15	63237	52
HDR48	79014	131	HSA200-EL15	76027	54	HSHD	73483	42	HV-1200-SAC-CS	62524	44
HDR54	79015	131	HSA200-EL15	76027	55	HSHD	73483	48	HV-1200-SAC-CS-EL15	63215	50
HDR60	79016	131	HSA8CL	62507	48	HSHD	73483	49	HV-1200-SAC-CS-S/S	62640	46
HDRBK	79009	131	HSA8CL	62507	49	HSHD	73483	54	HV-1200-SAC-CS-S/S-EL15	63236	52
HDRBK-HD	79072	131	HSA8CL	62507	50	HSHD	73483	55	HV-1400-2SAC-CL	62563	44

INDEX By Ordering Number

Ordering Number	Item Code	Page #	Ordering Number	Item Code	Page #	Ordering Number	Item Code	Page #	Ordering Number	Item Code	Page #
HV-1400-2SAC-CL-EL15	63427	50	HV-1800-SAC-CLL-EL15	63226	50	HV-3000-2SAC-CL-EL15	63451	50	HV1500L-PCST	63958	40
HV-1400-2SAC-CL-S/S	62679	46	HV-1800-SAC-CLL-S/S	62651	46	HV-3000-2SAC-CL-S/S	62703	46	HV1500L-PCST-S/S	64000	41
HV-1400-2SAC-CL-S/S-EL15	63459	52	HV-1800-SAC-CLL-S/S-EL15	63247	52	HV-3000-2SAC-CL-S/S-EL15	63483	52	HV1500L-S/S	75315	39
HV-1400-2SAC-CLL	62564	44	HV-1800-SAC-CM	62533	44	HV-3000-2SAC-CLL	62588	44	HV1500LL	73215	38
HV-1400-2SAC-CLL-EL15	63428	50	HV-1800-SAC-CM-EL15	63224	50	HV-3000-2SAC-CLL-EL15	63452	50	HV1500LL-PCST	63959	40
HV-1400-2SAC-CLL-S/S	62680	46	HV-1800-SAC-CM-S/S	62649	46	HV-3000-2SAC-CLL-S/S	62704	46	HV1500LL-PCST-S/S	64001	41
HV-1400-2SAC-CLL-S/S-EL15	63460	52	HV-1800-SAC-CM-S/S-EL15	63245	52	HV-3000-2SAC-CLL-S/S-EL15	63484	52	HV1500LL-S/S	75316	39
HV-1400-2SAC-CM	62562	44	HV-2000-2SAC-CL	62572	44	HV-3000-2SAC-CM	62586	44	HV1500M	73177	38
HV-1400-2SAC-CM-EL15	63426	50	HV-2000-2SAC-CL-EL15	63436	50	HV-3000-2SAC-CM-EL15	63450	50	HV1500M-PCST	63957	40
HV-1400-2SAC-CM-S/S	62678	46	HV-2000-2SAC-CL-S/S	62688	46	HV-3000-2SAC-CM-S/S	62702	46	HV1500M-PCST-S/S	63999	41
HV-1400-2SAC-CM-S/S-EL15	63458	52	HV-2000-2SAC-CL-S/S-EL15	63468	52	HV-3000-2SAC-CM-S/S-EL15	63482	52	HV1500M-S/S	75314	39
HV-1400-2SAC-CS	62561	44	HV-2000-2SAC-CLL	62573	44	HV-600-SAC-CL	62517	44	HV1600L	73638	38
HV-1400-2SAC-CS-EL15	63425	50	HV-2000-2SAC-CLL-EL15	63437	50	HV-600-SAC-CL-EL15	63208	50	HV1600L-PCST	63961	40
HV-1400-2SAC-CS-S/S	62677	46	HV-2000-2SAC-CLL-S/S	62689	46	HV-600-SAC-CL-S/S	62633	46	HV1600L-PCST-S/S	64003	41
HV-1400-2SAC-CS-S/S-EL15	63457	52	HV-2000-2SAC-CLL-S/S-EL15	63469	52	HV-600-SAC-CL-S/S-EL15	63229	52	HV1600L-S/S	75318	39
HV-1400-SAC-CL	62529	44	HV-2000-2SAC-CM	62571	44	HV-600-SAC-CM	62516	44	HV1600LL	73639	38
HV-1400-SAC-CL-EL15	63220	50	HV-2000-2SAC-CM-EL15	63435	50	HV-600-SAC-CM-EL15	63207	50	HV1600LL-PCST	63962	40
HV-1400-SAC-CL-S/S	62645	46	HV-2000-2SAC-CM-S/S	62687	46	HV-600-SAC-CM-S/S	62632	46	HV1600LL-PCST-S/S	64004	41
HV-1400-SAC-CL-S/S-EL15	63241	52	HV-2000-2SAC-CM-S/S-EL15	63467	52	HV-600-SAC-CM-S/S-EL15	63228	52	HV1600LL-S/S	75319	39
HV-1400-SAC-CM	62528	44	HV-2200-2SAC-CL	62575	44	HV-600-SAC-CS	62515	44	HV1600M	73637	38
HV-1400-SAC-CM-EL15	63219	50	HV-2200-2SAC-CL-EL15	63439	50	HV-600-SAC-CS-EL15	63206	50	HV1600M-PCST	63960	40
HV-1400-SAC-CM-S/S	62644	46	HV-2200-2SAC-CL-S/S	62691	46	HV-600-SAC-CS-S/S	62631	46	HV1600M-PCST-S/S	64002	41
HV-1400-SAC-CM-S/S-EL15	63240	52	HV-2200-2SAC-CL-S/S-EL15	63471	52	HV-600-SAC-CS-S/S-EL15	63227	52	HV1600M-S/S	75317	39
HV-1400-SAC-CS	62527	44	HV-2200-2SAC-CLL	62576	44	HV-800-SAC-CL	62520	44	HV1800L-PCST	63964	40
HV-1400-SAC-CS-EL15	63218	50	HV-2200-2SAC-CLL-EL15	63440	50	HV-800-SAC-CL-EL15	63211	50	HV1800LL-PCST	63965	40
HV-1400-SAC-CS-S/S	62643	46	HV-2200-2SAC-CLL-S/S	62692	46	HV-800-SAC-CL-S/S	62636	46	HV1800M-PCST	63963	40
HV-1400-SAC-CS-S/S-EL15	63239	52	HV-2200-2SAC-CLL-S/S-EL15	63472	52	HV-800-SAC-CL-S/S-EL15	63232	52	HV2100L-PCST	63967	40
HV-1600-2SAC-CL	62566	44	HV-2200-2SAC-CM	62574	44	HV-800-SAC-CM	62519	44	HV2100LL-PCST	63968	40
HV-1600-2SAC-CL-EL15	63430	50	HV-2200-2SAC-CM-EL15	63438	50	HV-800-SAC-CM-EL15	63210	50	HV2100M-PCST	63966	40
HV-1600-2SAC-CL-S/S	62582	46	HV-2200-2SAC-CM-S/S	62690	46	HV-800-SAC-CM-S/S	62635	46	HV2400L-PCST	63970	40
HV-1600-2SAC-CL-S/S-EL15	63462	52	HV-2200-2SAC-CM-S/S-EL15	63470	52	HV-800-SAC-CM-S/S-EL15	63231	52	HV2400LL-PCST	63971	40
HV-1600-2SAC-CLL	62567	44	HV-2400-2SAC-CL	62578	44	HV-800-SAC-CS	62518	44	HV2400M-PCST	63969	40
HV-1600-2SAC-CLL-EL15	63431	50	HV-2400-2SAC-CL-EL15	63442	50	HV-800-SAC-CS-EL15	63209	50	HV2600L-PCST	63973	40
HV-1600-2SAC-CLL-S/S	62683	46	HV-2400-2SAC-CL-S/S	62694	46	HV-800-SAC-CS-S/S	62634	46	HV2600LL-PCST	63974	40
HV-1600-2SAC-CLL-S/S-EL15	63463	52	HV-2400-2SAC-CL-S/S-EL15	63474	52	HV-800-SAC-CS-S/S-EL15	63230	52	HV2600M-PCST	63972	40
HV-1600-2SAC-CM	62565	44	HV-2400-2SAC-CLL	62579	44	HV1050L	73179	38	HV3000L-PCST	63976	40
HV-1600-2SAC-CM-EL15	63429	50	HV-2400-2SAC-CLL-EL15	63443	50	HV1050L-PCST	63952	40	HV3000LL-PCST	63977	40
HV-1600-2SAC-CM-S/S	62681	46	HV-2400-2SAC-CLL-S/S	62695	46	HV1050L-PCST-S/S	63994	41	HV3000M-PCST	63975	40
HV-1600-2SAC-CM-S/S-EL15	63461	52	HV-2400-2SAC-CLL-S/S-EL15	63475	52	HV1050L-S/S	75309	39	HV450M	73019	38
HV-1600-SAC-CL	62531	44	HV-2400-2SAC-CM	62577	44	HV1050M	73036	38	HV450M-PCST	63938	40
HV-1600-SAC-CL-EL15	63222	50	HV-2400-2SAC-CM-EL15	63441	50	HV1050M-PCST	63951	40	HV450M-PCST-S/S	63980	41
HV-1600-SAC-CL-S/S	62647	46	HV-2400-2SAC-CM-S/S	62693	46	HV1050M-PCST-S/S	63993	41	HV450M-S/S	75295	39
HV-1600-SAC-CL-S/S-EL15	63243	52	HV-2400-2SAC-CM-S/S-EL15	63473	52	HV1050M-S/S	75308	39	HV450S	73028	38
HV-1600-SAC-CLL	62532	44	HV-2600-2SAC-CL	62581	44	HV1050S	73056	38	HV450S-PCST	63937	40
HV-1600-SAC-CLL-EL15	63223	50	HV-2600-2SAC-CL-EL15	63445	50	HV1050S-PCST	63950	40	HV450S-PCST-S/S	63979	41
HV-1600-SAC-CLL-S/S	62648	46	HV-2600-2SAC-CL-S/S	62697	46	HV1050S-PCST-S/S	63992	41	HV450S-S/S	75294	39
HV-1600-SAC-CLL-S/S-EL15	63244	52	HV-2600-2SAC-CL-S/S-EL15	63477	52	HV1050S-S/S	75307	39	HV450SS	73026	38
HV-1600-SAC-CM	62530	44	HV-2600-2SAC-CLL	62582	44	HV1050SS	73057	38	HV450SS-PCST	63936	40
HV-1600-SAC-CM-EL15	63221	50	HV-2600-2SAC-CLL-EL15	63446	50	HV1050SS-PCST	64045	40	HV450SS-PCST-S/S	63978	41
HV-1600-SAC-CM-S/S	62646	46	HV-2600-2SAC-CLL-S/S	62698	46	HV1050SS-PCST-S/S	63991	41	HV450SS-S/S	75293	39
HV-1600-SAC-CM-S/S-EL15	63242	52	HV-2600-2SAC-CLL-S/S-EL15	63478	52	HV1050SS-S/S	75306	39	HV600M	73173	38
HV-1800-2SAC-CL	62569	44	HV-2600-2SAC-CM	62580	44	HV1200L	73180	38	HV600M-PCST	63941	40
HV-1800-2SAC-CL-EL15	63433	50	HV-2600-2SAC-CM-EL15	63444	50	HV1200L-PCST	63956	40	HV600M-PCST-S/S	63983	41
HV-1800-2SAC-CL-S/S	62685	46	HV-2600-2SAC-CM-S/S	62696	46	HV1200L-PCST-S/S	63998	41	HV600M-S/S	75298	39
HV-1800-2SAC-CL-S/S-EL15	63465	52	HV-2600-2SAC-CM-S/S-EL15	63476	52	HV1200L-S/S	75313	39	HV600S	73030	38
HV-1800-2SAC-CLL	62570	44	HV-2800-2SAC-CL	62584	44	HV1200M	73038	38	HV600S-PCST	63940	40
HV-1800-2SAC-CLL-EL15	63434	50	HV-2800-2SAC-CL-EL15	63448	50	HV1200M-PCST	63955	40	HV600S-PCST-S/S	63982	41
HV-1800-2SAC-CLL-S/S	62686	46	HV-2800-2SAC-CL-S/S	62700	46	HV1200M-PCST-S/S	63997	41	HV600S-S/S	75297	39
HV-1800-2SAC-CLL-S/S-EL15	63466	52	HV-2800-2SAC-CL-S/S-EL15	63480	52	HV1200M-S/S	75312	39	HV600SS	73045	38
HV-1800-2SAC-CM	62568	44	HV-2800-2SAC-CLL	62585	44	HV1200S	73058	38	HV600SS-PCST	63939	40
HV-1800-2SAC-CM-EL15	63432	50	HV-2800-2SAC-CLL-EL15	63449	50	HV1200S-PCST	63954	40	HV600SS-PCST-S/S	63981	41
HV-1800-2SAC-CM-S/S	62684	46	HV-2800-2SAC-CLL-S/S	62701	46	HV1200S-PCST-S/S	63996	41	HV600SS-S/S	75296	39
HV-1800-2SAC-CM-S/S-EL15	63464	52	HV-2800-2SAC-CLL-S/S-EL15	63481	52	HV1200S-S/S	75311	39	HV750M	73174	38
HV-1800-SAC-CL	62534	44	HV-2800-2SAC-CM	62583	44	HV1200SS	73059	38	HV750M-PCST	63944	40
HV-1800-SAC-CL-EL15	63225	50	HV-2800-2SAC-CM-EL15	63447	50	HV1200SS-PCST	63953	40	HV750M-PCST-S/S	63986	41
HV-1800-SAC-CL-S/S	62650	46	HV-2800-2SAC-CM-S/S	62699	46	HV1200SS-PCST-S/S	63995	41	HV750M-S/S	75301	39
HV-1800-SAC-CL-S/S-EL15	63246	52	HV-2800-2SAC-CM-S/S-EL15	63479	52	HV1200SS-S/S	75310	39	HV750S	73032	38
HV-1800-SAC-CLL	62535	44	HV-3000-2SAC-CL	62587	44	HV1500L	73158	38	HV750S-PCST	63943	40

INDEX By Ordering Number

Ordering Number	Item Code	Page #	Ordering Number	Item Code	Page #	Ordering Number	Item Code	Page #	Ordering Number	Item Code	Page #
HV750S-PCST-S/S	63985	41	HVPT-S/S	73631	38	HXF8M	74690	36	LA-30		175
HV750S-S/S	75300	39	HVPT-S/S	73631	39	HXF8M	74690	37	LA-36		175
HV750SS	73053	38	HVPT-S/S	73631	40	HXF8M-Blue	77520	36	LA-42		175
HV750SS-PCST	63942	40	HVPT-S/S	73631	41	HXF8M-Blue	77520	37	LA-48		175
HV750SS-PCST-S/S	63984	41	HVPT-S/S	73631	42	HXF8S	74689	36	LA-54		175
HV750SS-S/S	75299	39	HVPT-S/S	73631	46	HXF8S	74689	37	LA-60		175
HV900L	73178	38	HVPT-S/S	73631	48	HXF8S-Blue	77519	36	LA-66		175
HV900L-PCST	63948	40	HVPT-S/S	73631	49	HXF8S-Blue	77519	37	LA-72		175
HV900L-PCST-S/S	63990	41	HVPT-S/S	73631	52	HXF8SS	74307	36	LA-84		175
HV900L-S/S	75305	39	HVPT-S/S	73631	54	HXF8SS	74307	37	LA-96		
HV900M	73175	38	HVPT-S/S	73631	55	HXF8SS-Blue	77518	36	LS-BP	77114	12
HV900M-PCST	63947	40	HVT8-EL15-S/S	62254	54	HXF8SS-Blue	77518	37	LS-BP-S/S	77115	13
HV900M-PCST-S/S	63989	41	HVT8-EL15-S/S	63566	55	HXF900L	74667	36	LS-SP	77365	12
HV900M-S/S	75304	39	HVT8-S/S	75419	39	HXF900L-S/S	75274	37	LS-SS	77118	12
HV900S	73034	38	HVT8-S/S	75419	41	HXF900M	74666	36	LS-SS	77118	13
HV900S-PCST	63946	40	HVT8-S/S	75419	42	HXF900M-S/S	75273	37	LS-SW	77117	12
HV900S-PCST-S/S	63988	41	HVT8-S/S	75419	46	HXF900S	74665	36	LS-SW-S/S	78850	13
HV900S-S/S	75303	39	HVT8-S/S	75419	48	HXF900S-S/S	75272	37	LSP12	77070	12
HV900SS	73055	38	HVT8-S/S	75419	49	HXFHD1800L	74682	36	LSP12-S/S	77079	13
HV900SS-PCST	63945	40	HVT8-S/S	75419	52	HXFHD1800L-S/S	A1589	37	LSP18	77071	12
HV900SS-PCST-S/S	63987	41	HVT8-S/S	75419	54	HXFHD1800M	74681	36	LSP18-S/S	77080	13
HV900SS-S/S	75302	39	HVT8-S/S	75419	55	HXFHD1800M-S/S	A1588	37	LSP24	77072	12
HVC-S/S	73494	42	HW-BC	74100	133	HXFHD2100L	74684	36	LSP24-S/S	77081	13
HVHD1800L	74477	38	HW-IMPB	76939	149	HXFHD2100L-S/S	A1591	37	LSP30	77073	12
HVHD1800L-PCST-S/S	64006	41	HXF1050L	74670	36	HXFHD2100M	74683	36	LSP30-S/S	77082	13
HVHD1800L-S/S	A1595	39	HXF1050L-S/S	75277	37	HXFHD2100M-S/S	A1590	37	LSP36	77074	12
HVHD1800LL	74478	38	HXF1050M	74669	36	HXFHD2400L	74686	36	LSP36-S/S	77083	13
HVHD1800LL-PCST-S/S	64007	41	HXF1050M-S/S	75276	37	HXFHD2400L-S/S	A1593	37	LSP42	77075	12
HVHD1800LL-S/S	A1596	39	HXF1050S	74668	36	HXFHD2400M	74685	36	LSP42-S/S	77084	13
HVHD1800M	74602	38	HXF1050S-S/S	75275	37	HXFHD2400M-S/S	A1592	37	LSP48	77076	12
HVHD1800M-PCST-S/S	64005	41	HXF1200L	74673	36	IB4	76926	139	LSP48-S/S	77085	13
HVHD1800M-S/S	A1594	39	HXF1200L-S/S	75280	37	IB4	76926	141	LSP54	77077	12
HVHD2100L	74540	38	HXF1200M	74672	36	IB4	76926	143	LSP54-S/S	77086	13
HVHD2100L-PCST-S/S	64009	41	HXF1200M-S/S	75279	37	IB4	76926	145	LSP60	77078	12
HVHD2100L-S/S	A1598	39	HXF1200S	74671	36	IB4	76926	146	LSP60-S/S	77087	13
HVHD2100LL	74541	38	HXF1200S-S/S	75278	37	IB4	76926	147	LST-B-S/S	77124	13
HVHD2100LL-PCST-S/S	64010	41	HXF1500L	74678	36	IB4-1U	76965	149	LST-P	77121	12
HVHD2100LL-S/S	A1599	39	HXF1500L-S/S	75282	37	IB5	76927	139	LST-S	77123	12
HVHD2100M	74539	38	HXF1500M	74677	36	IB5	76927	141	LST-TAK	77120	12
HVHD2100M-PCST-S/S	64008	41	HXF1500M-S/S	75281	37	IB5	76927	143	LST-TAK	77120	13
HVHD2100M-S/S	A1597	39	HXF1600L	73444	36	IB5	76927	145	LST-W	77122	12
HVHD2400L	74545	38	HXF1600L-S/S	75284	37	IB5	76927	146	LST-W-S/S	77125	13
HVHD2400L-PCST-S/S	64012	41	HXF1600M	73443	36	IB5	76927	147	LST-W-S/S-2	77126	13
HVHD2400L-S/S	A1601	39	HXF1600M-S/S	75283	37	IB5	76927	148	LSTMPK	77366	12
HVHD2400LL	74546	38	HXF2-L	75982	36	IB5-1U	76966	149	LSTMPK-S/S	78933	13
HVHD2400LL-PCST-S/S	64013	41	HXF2-L	75982	37	IBBK	76928	145	LSTMPK2-S/S	78462	13
HVHD2400LL-S/S	A1602	39	HXF2-M	75981	36	IBBK	76928	146	LSTPB-RK	77367	12
HVHD2400M	74544	38	HXF2-M	75981	37	IBBK	76928	147	LSTPB-RK	77367	13
HVHD2400M-PCST-S/S	64011	41	HXF2-S	75980	36	IBBK	76928	148	MAIN FRAME		151
HVHD2400M-S/S	A1600	39	HXF2-S	75980	37	IBS-DH5	76934	147	MAK	74918	169
HVHD2600L	A2461	38	HXF2-SS	75979	36	IBS-DH5	76934	148	MAK-S/S	64926	169
HVHD2600L-PCST-S/S	64015	41	HXF2-SS	75979	37	IBS-H4	76933	147	MAKHD	74919	169
HVHD2600L-S/S	A2463	39	HXF450M	74660	36	IBS-L4	76929	145	MAKHD	74919	169
HVHD2600LL	A2397	38	HXF450M-S/S	75267	37	IBS-L5	76930	145	MAPEK	76024	134
HVHD2600LL-PCST-S/S	64016	41	HXF450S	74659	36	IBS-M1200	82397	143	MBADB	79527	122
HVHD2600LL-S/S	A2464	39	HXF450S-S/S	75266	37	IBS-M1500	82398	143	MBC-18	79494	120
HVHD2600M	A2396	38	HXF600M	74662	36	IBS-M4	76931	146	MBC-24	79495	120
HVHD2600M-PCST-S/S	64014	41	HXF600M-S/S	75269	37	IBS-M5	76932	146	MBC-30	79496	120
HVHD2600M-S/S	A2462	39	HXF600S	74661	36	IEA42-60D	76937	148	MBC-36	79497	120
HVHD3000L	74592	38	HXF600S-S/S	75268	37	IEA72-96D	76938	148	MBC-42	79498	120
HVHD3000L-PCST-S/S	64018	41	HXF750M	74664	36	IMK	76936	145	MBC-48	79499	120
HVHD3000L-S/S	A2466	39	HXF750M-S/S	75271	37	IMK	76936	146	MBC-54	79500	120
HVHD3000LL	74593	38	HXF750S	74663	36	IMK	76936	147	MBC-60	79501	120
HVHD3000LL-PCST-S/S	64019	41	HXF750S-S/S	75270	37	ISABK	76935	148	MBC-72	79502	120
HVHD3000LL-S/S	A2467	39	HXF8L	74691	36	ISABK-LMH	77529	145	MBC-84	79503	120
HVHD3000M	74591	38	HXF8L	74691	37	ISABK-LMH	77529	146	MBCB	79526	122
HVHD3000M-PCST-S/S	64017	41	HXF8L-Blue	77521	36	ISABK-LMH	77529	147	MBCBC	79525	122
HVHD3000M-S/S	A2465	39	HXF8L-Blue	77521	37	LA-24		175	MBCBL	79532	122

INDEX By Ordering Number

Ordering Number	Item Code	Page #	Ordering Number	Item Code	Page #	Ordering Number	Item Code	Page #	Ordering Number	Item Code	Page #
MBCBM	79528	122	MDWS-60	75874	116	MHCP-54A	75942	30	MHS-1050-MST-S/S	64033	72
MBCDBK	79536	120	MDWS-600-S/S	67466	116	MHCP-54S	75934	30	MHS-1050BTV	77484	75
MBCEC	79534	122	MDWS-72	75875	116	MHCP-600S-S/S	61504	33	MHS-1050BTV-S/S	77493	75
MBCM-1	79529	122	MDWS-750-S/S	67467	116	MHCP-600S-S/S-FR	61624	33	MHS-1050BTV-SAC	78010	103
MBCM-2	79530	122	MDWS-84	76806	116	MHCP-60A	75943	30	MHS-1050BTV-SAC-S/S	78319	103
MBCMCK	79524	122	MDWS-900-S/S	67468	116	MHCP-60S	75935	30	MHS-1050FPV	77792	77
MBCMCK	79533	122	MDWS-96	79063	116	MHCP-72A	75944	30	MHS-1050FPV-S/S	77802	77
MBCTA	79531	122	MDWS-MST-1050	67562	116	MHCP-72S	75936	30	MHS-1050V-SAC	78165	96
MBDS-18	79504	122	MDWS-MST-1050-S/S	67479	116	MHCP-750S-S/S	61505	33	MHS-1050V-SAC-S/S	78540	96
MBDS-24	79505	122	MDWS-MST-1200	67563	116	MHCP-750S-S/S-FR	61625	33	MHS-1200-MST	64024	72
MBDS-30	79506	122	MDWS-MST-1200-S/S	67480	116	MHCP-84A	76801	30	MHS-1200-MST-S/S	64034	72
MBDS-36	79507	122	MDWS-MST-1350	67564	116	MHCP-84S	76800	30	MHS-1200BTV	77525	75
MBDS-42	79508	122	MDWS-MST-1350-S/S	67481	116	MHCP-900S-S/S	61506	33	MHS-1200BTV-S/S	77526	75
MBDS-48	79509	122	MDWS-MST-1500	67565	116	MHCP-900S-S/S-FR	61626	33	MHS-1200BTV-SAC	78011	103
MBDS-54	79510	122	MDWS-MST-1500-S/S	67482	116	MHCP-BS	76394	32	MHS-1200BTV-SAC-S/S	78320	103
MBDS-60	79511	122	MDWS-MST-1800	67566	116	MHCP-CH	76393	32	MHS-1200FPV	77793	77
MBDS-72	79512	122	MDWS-MST-1800-S/S	67483	116	MHCP-S/S-CBK	61550	35	MHS-1200FPV-S/S	77803	77
MBDS-84	79513	122	MDWS-MST-2100	67567	116	MHCP-S/S-CEB	61549	35	MHS-1200V-SAC	78166	96
MBRD-18	79514	120	MDWS-MST-2100-S/S	67484	116	MHCP-S/S-CH	61548	35	MHS-1200V-SAC-S/S	78541	96
MBRD-18	79514	122	MDWS-MST-2400	67568	116	MHCP-S/S-CK1050	61538	35	MHS-1350-MST	64025	72
MBRD-24	79515	120	MDWS-MST-2400-S/S	67485	116	MHCP-S/S-CK1200	61539	35	MHS-1350-MST-S/S	64035	72
MBRD-24	79515	122	MDWS-MST-600	67559	116	MHCP-S/S-CK1350	61540	35	MHS-1350BTV	77485	75
MBRD-30	79516	120	MDWS-MST-600-S/S	67476	116	MHCP-S/S-CK1500	61541	35	MHS-1350BTV-S/S	77494	75
MBRD-30	79516	122	MDWS-MST-750	67560	116	MHCP-S/S-CK1650	61542	35	MHS-1350BTV-SAC	78012	103
MBRD-36	79517	120	MDWS-MST-750-S/S	67477	116	MHCP-S/S-CK1800	61543	35	MHS-1350BTV-SAC-S/S	78321	103
MBRD-36	79517	122	MDWS-MST-900	67561	116	MHCP-S/S-CK2100	61544	35	MHS-1350FPV	77794	77
MBRD-42	79518	120	MDWS-MST-900-S/S	67478	116	MHCP-S/S-CK2600	61535	35	MHS-1350FPV-S/S	77804	77
MBRD-42	79518	122	MESBK-PS	82364	112	MHCP-S/S-CK750	61536	35	MHS-1350V-SAC	78167	96
MBRD-42	79518	122	MESBK-PS	82364	113	MHCP-S/S-CK900	61537	35	MHS-1350V-SAC-S/S	78542	96
MBRD-48	79519	120	MESPBL	87895	112	MHCP-S/S-CKP	61545	35	MHS-1500-MST	64026	72
MBRD-48	79519	122	MESPBL-SS	82892	113	MHCP-S/S-CP 1050	61527	35	MHS-1500-MST-S/S	64036	72
MBRD-54	79520	120	MESPKR	81896	112	MHCP-S/S-CP 1200	61528	35	MHS-1500BTV	77486	75
MBRD-54	79520	122	MESPKR-SS	82894	113	MHCP-S/S-CP 1350	61529	35	MHS-1500BTV-2SAC	78015	103
MBRD-60	79521	120	MFASK	75531	169	MHCP-S/S-CP 1500	61530	35	MHS-1500BTV-2SAC-S/S	78324	103
MBRD-60	79521	122	MFASK	75531	169	MHCP-S/S-CP 1650	61531	35	MHS-1500BTV-S/S	77495	75
MBRD-72	79522	120	MHCP-1050S-S/S	61507	33	MHCP-S/S-CP 1800	61532	35	MHS-1500BTV-SAC	78013	103
MBRD-72	79522	122	MHCP-1050S-S/S-FR	61627	33	MHCP-S/S-CP 2100	61533	35	MHS-1500BTV-SAC-S/S	78322	103
MBRD-84	79523	120	MHCP-1200S-S/S	61508	33	MHCP-S/S-CP 600	61634	35	MHS-1500FPV	77795	77
MBRD-84	79523	122	MHCP-1200S-S/S-FR	61628	33	MHCP-S/S-CP 750	61525	35	MHS-1500FPV-S/S	77805	77
MCB	74925	169	MHCP-1350S-S/S	61509	33	MHCP-S/S-CP 900	61526	35	MHS-1500V-2SAC	78170	96
MCB	74925	169	MHCP-1350S-S/S-FR	61629	33	MHCP-S/S-PSTS	61547	35	MHS-1500V-2SAC-S/S	78545	96
MCBK	76025	169	MHCP-1500S-S/S	61510	33	MHCP-S/S-PSTW	61546	35	MHS-1500V-SAC	78168	96
MCBK	76025	169	MHCP-1500S-S/S-FR	61630	33	MHCP-SS/EP	61534	35	MHS-1500V-SAC-S/S	78543	96
MCBKHD	76026	169	MHCP-1650S-S/S	61511	33	MHP-CP1050	75964	32	MHS-1800-MST	64027	72
MCBKHD	76026	169	MHCP-1650S-S/S-FR	61631	33	MHP-CP1200	75965	32	MHS-1800-MST-S/S	64037	72
MCRK	74923	169	MHCP-1800S-S/S	61512	33	MHP-CP1400	75966	32	MHS-1800BTV	77487	75
MCRK	74923	169	MHCP-1800S-S/S-FR	61632	33	MHP-CP1500	75967	32	MHS-1800BTV-2SAC	78016	103
MCS	74930	169	MHCP-2100S-S/S	61513	33	MHP-CP1800	75968	32	MHS-1800BTV-2SAC-S/S	78325	103
MCS	74930	169	MHCP-2100S-S/S-FR	61633	33	MHP-CP2100	76811	32	MHS-1800BTV-S/S	77496	75
MCSHD	74931	169	MHCP-24A	75937	30	MHP-CP600	75961	32	MHS-1800BTV-SAC	78014	103
MCSHD	74931	169	MHCP-24S	75929	30	MHP-CP750	75962	32	MHS-1800BTV-SAC-S/S	78323	103
MCSK	74927	169	MHCP-2BC24	76638	32	MHP-CP900	75963	32	MHS-1800FPV	77796	77
MCSK	74927	169	MHCP-2BC30	76639	32	MHP-EP	76392	25	MHS-1800FPV-S/S	77806	77
MCSKHD	74928	169	MHCP-2BC36	76640	32	MHP-EP	76392	32	MHS-1800V-2SAC	78171	96
MCSKHD	74928	169	MHCP-2BC42	76641	32	MHP-EP	76392	49	MHS-1800V-2SAC-S/S	78546	96
MDWS-1050-S/S	67469	116	MHCP-2BC48	76642	32	MHP-EP	76392	55	MHS-1800V-SAC	78169	96
MDWS-1200-S/S	67470	116	MHCP-2BC54	76643	32	MHP-EP	76392	84	MHS-1800V-SAC-S/S	78544	96
MDWS-1350-S/S	67471	116	MHCP-2BC60	76644	32	MHP-EP	76392	91	MHS-1950BTV-2SAC-S/S	66255	103
MDWS-1500-S/S	67472	116	MHCP-2BC72	76645	32	MHP-EP	76392	98	MHS-1950V-2SAC-S/S	78649	96
MDWS-1800-S/S	67473	116	MHCP-2BC84	76812	32	MHP-EP	76392	105	MHS-2100-MST	64028	72
MDWS-2100-S/S	67474	116	MHCP-30A	75938	30	MHP-EP-S/S	77599	27	MHS-2100-MST-S/S	64038	72
MDWS-24	75868	116	MHCP-30S	75930	30	MHP-EP-S/S	77599	49	MHS-2100BTV	77488	75
MDWS-2400-S/S	67475	116	MHCP-36A	75939	30	MHP-EP-S/S	77599	55	MHS-2100BTV-2SAC	78017	103
MDWS-30	75869	116	MHCP-36S	75931	30	MHP-EP-S/S	77599	86	MHS-2100BTV-2SAC-S/S	78326	103
MDWS-36	75870	116	MHCP-42A	75940	30	MHP-EP-S/S	77599	93	MHS-2100BTV-S/S	77497	75
MDWS-42	75871	116	MHCP-42S	75932	30	MHP-EP-S/S	77599	100	MHS-2100FPV	77797	77
MDWS-48	75872	116	MHCP-48A	75941	30	MHP-EP-S/S	77599	106	MHS-2100FPV-S/S	77807	77
MDWS-54	75873	116	MHCP-48S	75933	30	MHS-1050-MST	64023	72	MHS-2100V-2SAC	78172	96

INDEX By Ordering Number

Ordering Number	Item Code	Page #	Ordering Number	Item Code	Page #	Ordering Number	Item Code	Page #	Ordering Number	Item Code	Page #
MHS-2100V-2SAC-S/S	78547	96	MHS-CARK-V48/1200	77941	97	MHS-P1350	77503	73	MMP-636-S/S	77426	24
MHS-2400-MST	64029	72	MHS-CARK-V48/1200	77941	104	MHS-P1350	77503	78	MMP-642	76453	23
MHS-2400-MST-S/S	64039	72	MHS-CARK-V48/1200-S/S			MHS-P1350	77503	76	MMP-642-S/S	77427	24
MHS-2400BTV	77489	75	MVECKS/S	82845	97	MHS-P1350S/S	77512	71	MMP-648	76454	23
MHS-2400BTV-2SAC	78018	103	MHS-CARK-V48/1200-S/S			MHS-P1350S/S	77512	73	MMP-648-S/S	77428	24
MHS-2400BTV-2SAC-S/S	78327	103	MVECKS/S	82845	104	MHS-P1350S/S	77512	78	MMP-654	76455	23
MHS-2400BTV-S/S	77498	75	MHS-CARK-V54/1350	77942	97	MHS-P1350S/S	77512	76	MMP-654-S/S	77429	24
MHS-2400FPV	77798	77	MHS-CARK-V54/1350	77942	104	MHS-P1500	77504	71	MMP-660	76456	23
MHS-2400FPV-S/S	77808	77	MHS-CARK-V54/1350-S/S			MHS-P1500	77504	73	MMP-660-S/S	77430	24
MHS-2400V-2SAC	78173	96	MVECKS/S	82846	97	MHS-P1500	77504	78	MMP-672	76457	23
MHS-2400V-2SAC-S/S	78548	96	MHS-CARK-V54/1350-S/S			MHS-P1500	77504	76	MMP-672-S/S	77431	24
MHS-3000BTV-2SAC	78019	103	MVECKS/S	82846	104	MHS-P1500S/S	77513	71	MMP-684	76798	23
MHS-3000BTV-2SAC-S/S	78328	103	MHS-CARK-V60/1500	77943	97	MHS-P1500S/S	77513	73	MMP-684-S/S	77432	24
MHS-3000V-2SAC	78174	96	MHS-CARK-V60/1500	77943	104	MHS-P1500S/S	77513	78	MMPBPK	76466	25
MHS-3000V-2SAC-S/S	78549	96	MVECKS/S	82847	97	MHS-P1500S/S	77513	76	MMPBPK-S/S	77600	27
MHS-600-MST	64020	72	MHS-CARK-V60/1500-S/S			MHS-P1800	77505	71	MMPCP24	76458	25
MHS-600-MST-S/S	64030	72	MVECKS/S	82847	104	MHS-P1800	77505	73	MMPCP24-S/S	77590	27
MHS-600BTV	77481	75	MHS-CARK-V72/1800	77944	97	MHS-P1800	77505	78	MMPCP30	76459	25
MHS-600BTV-S/S	77490	75	MHS-CARK-V72/1800	77944	104	MHS-P1800	77505	76	MMPCP30-S/S	77591	27
MHS-600BTV-SAC	78007	103	MHS-CARK-V72/1800-S/S			MHS-P1800S/S	77514	71	MMPCP36	76460	25
MHS-600BTV-SAC-S/S	78316	103	MVECKS/S	82848	97	MHS-P1800S/S	77514	73	MMPCP36-S/S	77592	27
MHS-600FPV	77789	77	MHS-CARK-V72/1800-S/S			MHS-P1800S/S	77514	78	MMPCP42	76461	25
MHS-600FPV-S/S	77799	77	MVECKS/S	82848	104	MHS-P1800S/S	77514	76	MMPCP42-S/S	77593	27
MHS-600V-SAC	78162	96	MHS-CARK2-V120/3000	77954	97	MHS-P2100	77506	73	MMPCP48	76462	25
MHS-600V-SAC-S/S	78537	96	MHS-CARK2-V120/3000	77954	104	MHS-P2100	77506	78	MMPCP48-S/S	77594	27
MHS-750-MST	64021	72	MHS-CARK2-V120/3000-S/S			MHS-P2100	77506	76	MMPCP54	76463	25
MHS-750-MST-S/S	64031	72	MV2CKS	82853	97	MHS-P2100S/S	77515	73	MMPCP54-S/S	77595	27
MHS-750BTV	77482	75	MHS-CARK2-V120/3000-S/S			MHS-P2100S/S	77515	78	MMPCP60	76464	25
MHS-750BTV-S/S	77491	75	MV2CKS	82853	104	MHS-P2100S/S	77515	76	MMPCP60-S/S	77596	27
MHS-750BTV-SAC	78008	103	MHS-CARK2-V60/1500	77950	97	MHS-P2400	77507	73	MMPCP72	76465	25
MHS-750BTV-SAC-S/S	78317	103	MHS-CARK2-V60/1500	77950	104	MHS-P2400	77507	78	MMPCP72-S/S	77597	27
MHS-750FPV	77790	77	MVECKS/S	82849	97	MHS-P2400	77507	76	MMPCP84	76808	25
MHS-750FPV-S/S	77800	77	MHS-CARK2-V60/1500-S/S			MHS-P2400S/S	77516	73	MMPCP84-S/S	77598	27
MHS-750V-SAC	78163	96	MV2CKSS	82849	104	MHS-P2400S/S	77516	78	MORK	74921	169
MHS-750V-SAC-S/S	78538	96	MHS-CARK2-V72/1800	77951	97	MHS-P2400S/S	77516	76	MORK	74921	169
MHS-900-MST	64022	72	MHS-CARK2-V72/1800	77951	104	MHS-P600	77499	71	MPSTA-S/S	82289	113
MHS-900-MST-S/S	64032	72	MHS-CARK2-V72/1800-S/S			MHS-P600	77499	73	MQMTSBK-SS	82895	113
MHS-900BTV	77483	75	MV2CKSS	82850	97	MHS-P600	77499	78	MR-1050PG	A2840	130
MHS-900BTV-S/S	77492	75	MHS-CARK2-V72/1800-S/S			MHS-P600	77499	76	MR-1200PG	A2841	130
MHS-900BTV-SAC	78009	103	MV2CKSS	82850	104	MHS-P600S/S	77508	71	MR-1500PG	A2829	130
MHS-900BTV-SAC-S/S	78318	103	MHS-CARK2-V84/2100	77952	97	MHS-P600S/S	77508	73	MR-1600PG	A2830	130
MHS-900FPV	77791	77	MHS-CARK2-V84/2100	77952	104	MHS-P600S/S	77508	78	MR-1800PG	A2831	130
MHS-900FPV-S/S	77801	77	MV2CKSS	82851	97	MHS-P600S/S	77508	76	MR-2100PG	A2832	130
MHS-900V-SAC	78164	96	MHS-CARK2-V84/2100-S/S			MHS-P750	77500	71	MR-2400PG	A2833	130
MHS-900V-SAC-S/S	78539	96	MV2CKSS	82851	104	MHS-P750	77500	73	MR-2600PG	A2834	130
MHS-CARK-V24/600	77937	97	MHS-CARK2-V96/2400	77953	97	MHS-P750	77500	78	MR-3000PG	A2835	130
MHS-CARK-V24/600	77937	104	MHS-CARK2-V96/2400	77953	104	MHS-P750	77500	76	MR-450PG	A2836	130
MHS-CARK-V24/600-S/S			MV2CKSS	82852	97	MHS-P750S/S	77509	71	MR-600PG	A2837	130
MVECKS/S	82841	97	MHS-CARK2-V96/2400-S/S			MHS-P750S/S	77509	73	MR-750PG	A2838	130
MHS-CARK-V24/600-S/S			MV2CKSS	82852	104	MHS-P750S/S	77509	78	MR-900PG	A2839	130
MVECKS/S	82841	104	MHS-P1050	77502	71	MHS-P750S/S	77509	76	MSPBPK-S/S	77583	18
MHS-CARK-V30/750	77938	97	MHS-P1050	77502	73	MHS-P900	77501	71	MSPMPK	75811	25
MHS-CARK-V30/750	77938	104	MHS-P1050	77502	78	MHS-P900	77501	73	MSPMPK-S/S	77582	27
MHS-CARK-V30/750-S/S			MHS-P1050	77502	76	MHS-P900	77501	78	MSPP30	75804	117
MVECKS/S	82842	97	MHS-P1050	77502	76	MHS-P900*	77501	76	MSPP30-S/S	77473	117
MHS-CARK-V30/750-S/S			MHS-P1050S/S	77511	71	MHS-P900S/S	77510	71	MSPP36	75805	117
MVECKS/S	82842	104	MHS-P1050S/S	77511	73	MHS-P900S/S	77510	73	MSPP36-S/S	77474	117
MHS-CARK-V36/900	77939	97	MHS-P1050S/S	77511	78	MHS-P900S/S	77510	78	MSPP42	75806	117
MHS-CARK-V36/900	77939	104	MHS-P1200	77527	71	MHS-P900S/S	77510	76	MSPP42-S/S	77475	117
MHS-CARK-V36/900-S/S			MHS-P1200	77527	73	MMKU	77324	112	MSPP48	75807	117
MVECKS/S	82843	97	MHS-P1200	77527	78	MMKU-SS	77357	113	MSPP48-S/S	77476	117
MHS-CARK-V36/900-S/S			MHS-P1200*	77527	76	MMKUHD-SS	77358	113	MSPP54	75808	117
MVECKS/S	82843	104	MHS-P1200S/S	77528	71	MMP-624	76450	23	MSPP54-S/S	77477	117
MHS-CARK-V42/1050	77940	97	MHS-P1200S/S	77528	73	MMP-624-S/S	77424	24	MSPP60	75809	117
MHS-CARK-V42/1050	77940	104	MHS-P1200S/S	77528	78	MMP-630	76451	23	MSPP60-S/S	77478	117
MHS-CARK-V42/1050-S/S			MHS-P1200S/S	77528	76	MMP-630-S/S	77425	24	MSPP66	76695	117
MVECKS/S	82844	97	MHS-P1350	77503	71	MMP-636	76452	23	MSPP66-S/S	77479	117
MHS-CARK-V42/1050-S/S									MSR	74914	167
MVECKS/S	82844	104									

INDEX By Ordering Number

Ordering Number	Item Code	Page #	Ordering Number	Item Code	Page #	Ordering Number	Item Code	Page #	Ordering Number	Item Code	Page #
MSR	74914	169	NI6D3T-48-17-A45	26188	139	PATHK	78794	29	PMR-CHB-L73	61075	130
MSR-S/S	64924	169	NI6D3T-54-19-A45	26189	139	PATLK	78791	29	PMR-CHB-R60	61074	130
MSR2-S/S	79378	168	NI6D3T-60-21-A45	26190	139	PBC-1	61356	176	PMR-CHB-R73	61076	130
MST LOCK PIN SS	G2309	118	NI6D3T-72-25-A45	26191	139	PBC-2	61357	176	PMSMK	74916	169
MST-MBL	79436	74	OIBBK	76950	149	PBC-FR	61358	176	PMSMK-S/S	64925	169
MST-MBR	79437	74	P-CARK-V24/600	78080	83	PCAP-24/600	77913	85	PP1050	73011	66
MSTAM	79435	71	P-CARK-V24/600-S/S			PCAP-24/600-S/S	78355	87	PP1050-S/S	75386	66
MSTAM	79435	73	PVECKS/S	82815	83	PCAP-30/750	77914	85	PP1200	73013	66
MSTAM	79435	117	P-CARK-V30/750	78081	83	PCAP-30/750-S/S	78356	87	PP1200-S/S	75387	66
MSTAM-S/S	64931	71	P-CARK-V30/750-S/S			PCAP-36/900	77915	85	PP1400	73015	66
MSTAM-S/S	64931	73	PVECKS/S	82816	83	PCAP-36/900-S/S	78357	87	PP1400-S/S	75388	66
MSTAM-S/S	64931	117	P-CARK-V36/900	78082	83	PCAP-42/1050	77916	85	PP1500	73016	66
MSTBBK	63067	71	P-CARK-V36/900-S/S			PCAP-42/1050-S/S	78358	87	PP1500-S/S	75389	66
MSTBBK	63067	71	PVECKS/S	82817	83	PCAP-48/1200	77917	85	PP450	73003	66
MSTBBK	63067	73	P-CARK-V42/1050	78083	83	PCAP-48/1200-S/S	78359	87	PP450-S/S	75382	66
MSTBBK	63067	73	P-CARK-V42/1050-S/S			PCAP-54/1350	77918	85	PP600	73005	66
MSTBBK	63067	73	PVECKS/S	82818	83	PCAP-54/1350-S/S	78360	87	PP600-S/S	75383	66
MSTBBK	63067	117	P-CARK-V48/1200	78084	83	PCAP-60/1500	77919	85	PP750	73007	66
MSTBBK	63067	117	P-CARK-V48/1200-S/S			PCAP-60/1500-S/S	78361	87	PP750-S/S	75384	66
MSTDB	79434	74	PVECKS/S	82819	83	PCAP-72/1800	77920	85	PP900	73009	66
MSTHD-B	79433	71	P-CARK-V54/1350	78085	83	PCAP-72/1800-S/S	78362	87	PP900-S/S	75385	66
MSTHD-B	79433	73	P-CARK-V54/1350-S/S			PCB	75507	62	PPHD1800	74597	66
MSTHD-B	79433	117	PVECKS/S	82820	83	PFC-P-S/S	79289	66	PPHD1800-S/S	A1781	66
MSTHD-B-S/S	90183	64	P-CARK-V60/1500	78086	83	PHA	73626	66	PPHD2000	74556	66
MSTHD-B-S/S	90183	71	P-CARK-V60/1500-S/S			PHA	73626	85	PPHD2000-S/S	A2120	66
MSTHD-B-S/S	90183	117	PVECKS/S	82821	83	PHDCB	75510	63	PPHD2100	A2803	66
MSTHD-G	63020	71	P-CARK-V72/1800	78087	83	PHSC-S/S	73433	66	PPHD2100-S/S	A1613	66
MSTHD-G	63020	73	P-CARK-V72/1800-S/S			PHSC-S/S	73433	87	PPHD2400	74557	66
MSTHD-G	63020	117	PVECKS/S	82822	83	PHSC-S/S	73433	129	PPHD2400-S/S	A1775	66
MSTHD-G-S/S	90184	64	P-CARK2-V120/3000	78097	83	PMB	75895	32	PPS6	73024	66
MSTHD-G-S/S	90184	71	P-CARK2-V120/3000-S/S			PMBL	75516	85	PS1050	73543	129
MSTHD-G-S/S	90184	117	PV2ECKSS	82827	83	PMBL	75516	92	PS1050PL	73585	129
MSTHD-S	79432	71	P-CARK2-V60/1500	78093	83	PMBL	75516	105	PS1200	73544	129
MSTHD-S	79432	73	P-CARK2-V60/1500-S/S			PMBL	75516	123	PS1200PL	73586	129
MSTHD-S	79432	117	PV2ECKSS	82823	83	PMBL (left)	75516	62	PS1400	73546	129
MSTHD-S-S/S	90182	64	P-CARK2-V72/1800	78094	83	PMBL (left)	75516	63	PS1400PL	73587	129
MSTHD-S-S/S	90182	71	P-CARK2-V72/1800-S/S			PMBL (left)	75516	66	PS1500	73545	129
MSTHD-S-S/S	90182	117	PV2ECKSS	82824	83	PMBL (left)	75516	68	PS1500PL	73588	129
MSTHD-SS-B	90183	73	P-CARK2-V78/1950-S/S	82876	83	PMBL (left)	75516	76	PS1800	73537	129
MSTHD-SS-G	90184	73	PV2ECKSS	82876	83	PMBL (left)	75516	68	PS1800PL	74049	129
MSTHD-SS-S	90184	73	P-CARK2-V84/2100	78095	83	PMBL (left)	75516	68	PS2000	73539	129
MSTHD-SS-S	90182	73	P-CARK2-V84/2100-S/S			PMBL (right)	75519	66	PS2000 PL	74050	129
MSTHD-SS-W	90181	73	PV2ECKSS	82825	83	PMBL (right)	75519	68	PS600	73014	129
MSTHD-W	79431	71	P-CARK2-V96/2400	78096	83	PMBL (right)	75519	76	PS600PL	73582	129
MSTHD-W	79431	73	P-CARK2-V96/2400-S/S			PMBL (right)	75519	76	PS750	73541	129
MSTHD-W	79431	117	PV2ECKSS	82826	83	PMBL-S/S	75518	74	PS750PL	73583	129
MSTHD-W-S/S	90181	71	CCMK	78919	62	PMBL-S/S	75518	79	PS900	73542	129
MSTHD-W-S/S	90181	117	PAB	75513	62	PMBL-S/S	75518	87	PS900PL	73584	129
MSTLP	64930	71	PAB	75513	63	PMBL-S/S	75518	94	PSA150	73156	66
MSTLP	64930	71	PAB	75513	66	PMBL-S/S	75518	99	PSA150 (V-Tip)	73156	82
MSTLP	64930	71	PAB	75513	68	PMBL-S/S	75518	107	PSN11010	74053	129
MSTLP	64930	73	PAB	75513	76	PMBL-S/S (left)	75518	66	PSR-L	74560	158
MSTLP	64930	73	PAB	75513	85	PMBL-S/S (left)	75518	68	PSR-L-F	62352	158
MSTLP	64930	117	PAB	75513	92	PMBL-S/S (left)	75518	76	PSR-M	74559	158
MSTLP	64930	117	PAB	75513	105	PMBL-S/S (left)	75518	76	PSR-M-F	62351	158
MUPSBK	82896	112	PAB	75513	123	PMBL-S/S (right)	75521	66	PSR-S	74558	158
MUPSBK-SS	82893	113	PAB	75513	66	PMBL-S/S (right)	75521	68	PSR-S-F	62350	158
FLCK	77729	176	PAB-S/S	75515	68	PMBL-S/S (right)	75521	76	PSR-XL	74561	158
N6D3T-24-9-A45	26107	137	PAB-S/S	75515	68	PMBR	75519	85	PSR-XL-F	62353	158
N6D3T-30-11-A45	26108	137	PAB-S/S	75515	76	PMBR	75519	92	PSSS	74773	66
N6D3T-36-13-A45	26109	137	PAB-S/S	75515	87	PMBR	75519	105	PSSS-H	73222	129
N6D3T-42-15-A45	26110	137	PAB-S/S	75515	94	PMBR	75519	123	PSSS-N	73221	129
N6D3T-48-17-A45	26111	137	PAB-S/S	75515	107	PMBR (right)	75519	62	PST2-S	77724	32
N6D3T-54-19-A45	26112	137	PACB100	79656	74	PMBR (right)	75519	63	PST2-W	77723	32
N6D3T-60-21-A45	26113	137	PACB100	79656	79	PMBR-S/S	75521	74	PSTA	75896	25
N6D3T-72-25-A45	26114	137	PACB100	79656	99	PMBR-S/S	75521	79	PSTA	75896	32
N6D3T-72-25-A45	26114	137	PACB60	78683	74	PMBR-S/S	75521	87			
NI6D3T-24-9-A45	26184	139	PACB60	78683	79	PMBR-S/S	75521	94			
NI6D3T-30-11-A45	26185	139	PACB60	78683	99	PMBR-S/S	75521	99			
NI6D3T-36-13-A45	26186	139	PAT1	78684	29	PMBR-S/S	75521	107			
NI6D3T-42-15-A45	26187	139	PAT2	78685	29	PMR-CHB-L60	61073	130			

INDEX By Ordering Number

Ordering Number	Item Code	Page #	Ordering Number	Item Code	Page #	Ordering Number	Item Code	Page #	Ordering Number	Item Code	Page #
PSTA-S/S	77442	27	PTM-1800-2		167	PTS-RR45	77684	164	QMTBK-G	76540	25
PSTS-S	75899	32	PTM-1800-2-S/S		168	PTS-RR51	77685	164	QMTBK-G	76540	27
PSTS-S	75899	35	PTM-1800-3		167	PTS-RR57	77686	164	QMTBK-GCN	82174	112
PSTS-S	75899	43	PTM-1800-3-S/S		168	PTS-RR63	77687	164	QMTBK-GCN	82174	113
PSTS-S-S/S	79056	43	PTM-2000-1		167	PTS-RR75	77689	164	QMTBK-P	76097	25
PSTS-W	75898	25	PTM-2000-1-S/S		168	PTS-SAK	77694	165	QMTBK-P	76097	27
PSTS-W	75898	32	PTM-2000-2		167	PTS-SR	77691	165	QMTBK-W	76098	25
PSTS-W	75898	35	PTM-2000-2-S/S		168	PV1050	73010	65	QMTBK-W	76098	27
PSTS-W	75898	112	PTM-2000-3		167	PV1050-S/S	75327	65	QMTBK-W	76098	32
PSVA	73434	129	PTM-2000-3-S/S		168	PV1050-SAC	78023	82	QMTBK-W	76098	35
PTEZ-1050	90269	160	PTM-2400-1		167	PV1050-SAC-S/S	78332	82	QMTBK-WS-MT	82175	112
PTEZ-1200	90270	160	PTM-2400-1-S/S		168	PV1200	73012	65	QMTBK-WS-MT	82175	113
PTEZ-450	90265	160	PTM-2400-2		167	PV1200-S/S	75328	65	QMTPAK	76096	25
PTEZ-600	90266	160	PTM-2400-2-S/S		168	PV1200-SAC	78024	82	QMTPAK-S/S	77587	27
PTEZ-750	90267	160	PTM-2400-3		167	PV1200-SAC-S/S	78333	82	QMTPSBK	76099	25
PTEZ-900	90268	160	PTM-2400-3-S/S		168	PV1350-SAC	78025	82	QMTPSBK-CN	82182	112
PTEZDC	90353	160	PTM-2600-1		167	PV1350-SAC-S/S	78334	82	QMTPSBK-S/S	77588	27
PTEZHD-1050	90616	160	PTM-2600-1-S/S		168	PV1400	73436	65	QMTS-G	76484	25
PTEZHD-1200	90617	160	PTM-2600-2		167	PV1400-S/S	75329	65	QMTS-G-S/S	77452	18
PTEZHD-1350	90618	160	PTM-2600-2-S/S		168	PV1500	73437	65	QMTS-G-S/S	77452	27
PTEZHD-1500	90795	160	PTM-2600-3		167	PV1500-2SAC	78028	82	QMTS-G-SS	77452	113
PTEZHD-1500	90619	160	PTM-2600-3-S/S		168	PV1500-2SAC-S/S	78337	82	QMTS-P	75845	17
PTEZHD-1600	90796	160	PTM-3000-1		167	PV1500-S/S	75330	65	QMTS-P	75845	25
PTEZHD-1800	90620	160	PTM-3000-1-S/S		168	PV1500-SAC	78026	82	QMTS-P	75845	112
PTEZHD-2000	90797	160	PTM-3000-2		167	PV1500-SAC-S/S	78335	82	QMTS-P-S/S	77450	18
PTEZHD-2100	90621	160	PTM-3000-2-S/S		168	PV1800-2SAC	78029	82	QMTS-P-S/S	77450	27
PTEZHD-DCK	90805	160	PTM-3000-3		167	PV1800-2SAC-S/S	78338	82	QMTS-P-SS	77450	113
PTEZHD-JBBK	90807	160	PTM-3000-3-S/S		168	PV1800-SAC	78027	82	QMTS-W-S/S	77451	18
PTEZHD-MBK	90803	160	PTM-750-1		167	PV1800-SAC-S/S	78336	82	QMTS-W-SS	77451	113
PTEZHD-PBK	90804	160	PTM-750-1-S/S		168	PV1950-2SAC-S/S	78656	82	QSTS-W-S/S	77451	27
PTEZHD-WRBK	90806	160	PTM-750-2		167	PV2100-2SAC	78030	82	R-CARK-V24/600	78106	90
PTEZMB	90351	160	PTM-750-2-S/S		168	PV2100-2SAC-S/S	78339	82	R-CARK-V24/600-S/S		
PTEZPB	90352	160	PTM-750-3		167	PV2400-2SAC	78031	82	RVECKS/S	82828	90
PTK	65746	73	PTM-750-3-S/S		168	PV2400-2SAC-S/S	78340	82	R-CARK-V30/750	78107	90
PTK	65746	73	PTM-900-1		167	PV3000-2SAC	78032	82	R-CARK-V30/750-S/S		
PTK	65746	76	PTM-900-1-S/S		168	PV3000-2SAC-S/S	78341	82	RVECKS/S	82829	90
PTK	65746	76	PTM-900-2		167	PV450	73435	65	R-CARK-V36/900	78108	90
PTK	65746	78	PTM-900-2-S/S		168	PV450-S/S	75323	65	R-CARK-V36/900-S/S		
PTK	65746	78	PTM-900-3		167	PV600	73004	65	RVECKS/S	82830	90
PTM-1050-1		167	PTM-900-3-S/S		168	PV600-S/S	75324	65	R-CARK-V42/1050	78109	90
PTM-1050-1-S/S		168	PTMSR	A0235	167	PV600-SAC	78020	82	R-CARK-V42/1050-S/S		
PTM-1050-2		167	PTPK	75897	32	PV600-SAC-S/S	78329	82	RVECKS/S	82831	90
PTM-1050-2-S/S		168	PTPK-MT	82343	112	PV750	73006	65	R-CARK-V48/1200	78110	90
PTM-1050-3		167	PTPK-MT-S/S	82342	113	PV750-S/S	75325	65	R-CARK-V48/1200-S/S		
PTM-1050-3-S/S		168	PTS-18R	77664	164	PV750-SAC	78021	82	RVECKS/S	82832	90
PTM-1200-1		167	PTS-24R	77665	164	PV750-SAC-S/S	78330	82	R-CARK-V54/1350	78111	90
PTM-1200-1-S/S		168	PTS-30R	77666	164	PV900	73008	65	R-CARK-V54/1350-S/S		
PTM-1200-2		167	PTS-36R	77667	164	PV900-S/S	75326	65	RVECKS/S	82833	90
PTM-1200-2-S/S		168	PTS-42R	77668	164	PV900-SAC	78022	82	R-CARK-V60/1500	78112	90
PTM-1200-3		167	PTS-48R	77669	164	PV900-SAC-S/S	78331	82	R-CARK-V60/1500-S/S		
PTM-1200-3-S/S		168	PTS-54R	77670	164	PVHD1800	74598	65	RVECKS/S	82834	90
PTM-1350-1		167	PTS-60R	77671	164	PVHD1800-S/S	A1603	65	R-CARK-V72/1800	78113	90
PTM-1350-1-S/S		168	PTS-72R	77672	164	PVHD2000	75452	65	R-CARK-V72/1800-S/S		
PTM-1350-2		167	PTS-ABK	77693	165	PVHD2000-S/S	A2046	65	RVECKS/S	82835	90
PTM-1350-2-S/S		168	PTS-EBK	77702	165	PVHD2100	74553	65	R-CARK2-V120/3000	78123	90
PTM-1350-3		167	PTS-HDSR	77692	165	PVHD2100-S/S	A1604	65	R-CARK2-V120/3000-S/S		
PTM-1350-3-S/S		168	PTS-HIBK	77697	165	PVHD2400	74555	65	RV2ECKSS	82840	90
PTM-1500-1		167	PTS-IBK	77696	165	PVHD2400-S/S	A1605	65	R-CARK2-V60/1500	78119	90
PTM-1500-2		167	PTS-LHSAA	77756	165	PVT6-S/S	75420	66	R-CARK2-V60/1500-S/S		
PTM-1500-3		167	PTS-MBK	77700	165	PVT6-S/S	75420	87	RV2ECKSS	82836	90
PTM-1600-1		167	PTS-MBKUG	77701	165	PVT6-S/S	75420	129	R-CARK2-V72/1800	78120	90
PTM-1600-1-S/S		168	PTS-PA	77699	165	QMT-G	76483	25	R-CARK2-V72/1800-S/S		
PTM-1600-2		167	PTS-PS	77698	165	QMT-G	76484	112	RV2ECKSS	82837	90
PTM-1600-2-S/S		168	PTS-RHSAA	77755	165	QMT-G-S/S	77586	27	R-CARK2-V84/2100	78121	90
PTM-1600-3		167	PTS-RR21	77680	164	QMT-P	76074	25	RV2ECKSS	82838	90
PTM-1600-3-S/S		168	PTS-RR27	77681	164	QMT-P	77584	27	R-CARK2-V96/2400	78122	90
PTM-1800-1		167	PTS-RR33	77682	164	QMT-P-S/S	77584	27	R-CARK2-V96/2400-S/S		
PTM-1800-1-S/S		168	PTS-RR39	77683	164	QMT-W	76075	25	RV2ECKSS	82839	90
						QMT-W-S/S	77585	27	RBPCP	73162	159

INDEX By Ordering Number

Ordering Number	Item Code	Page #	Ordering Number	Item Code	Page #	Ordering Number	Item Code	Page #	Ordering Number	Item Code	Page #
RBPBK-L	73948	159	RS-1-15-30-35		174	RV900-SAC	78035	89	SACPL-48/1200	77891	91
RBPBK-M	73947	159	RS-1-15-36-35		174	RV900-SAC-S/S	78344	89	SACPL-48/1200	77891	98
RBPBK-S	73946	159	RS-1-15-42-35		174	RVHD1800	74642	67	SACPL-48/1200	77891	105
RBPBK-XL	73949	159	RS-1-15-48-35		174	RVHD1800-S/S	A1626	67	SACPL-48/1200-S/S	78375	86
RBPMBK	74327	159	RS-1-15-54-35		174	RVHD2000	75463	67	SACPL-48/1200-S/S	78375	93
RBPRET	A1622	159	RS-1-15-60-35		174	RVHD2100	74643	67	SACPL-48/1200-S/S	78375	100
RBPRET	73163	165	RS-1-15-66-35		174	RVHD2100-S/S	A1628	67	SACPL-48/1200-S/S	78375	106
RBPSR-L	74564	159	RS-1-15-72-35		174	RVHD2400	74644	67	SACPL-54/1350	77892	84
RBPSR-L-CCT	28253	159	RS-1-15-84-35		174	RVHD2400-S/S	A1610	67	SACPL-54/1350	77892	91
RBPSR-M	74563	159	RS-1-15-96-35		174	RVT6-S/S	76205	68	SACPL-54/1350	77892	98
RBPSR-M-CCT	28251	159	RSA	76249	68	RVT6-S/S	76205	69	SACPL-54/1350	77892	105
RBPSR-S	74562	159	RSA	76249	92	RVT6-S/S	76205	71	SACPL-54/1350-S/S	78376	86
RBPSR-S-CCT	28250	159	RSA150	73628	68	RVT6-S/S	76205	73	SACPL-54/1350-S/S	78376	93
RBPSR-XL	74565	159	RSA150	73628	69	RVT6-S/S	76205	76	SACPL-54/1350-S/S	78376	100
RBPSR-XL-CCT	28254	159	RSA150	73628	71	RVT6-S/S	76205	78	SACPL-54/1350-S/S	78376	106
RC-S/S	76250	68	RSA150	73628	73	RVT6-S/S	76205	94	SACPL-60/1500	77893	84
RC-S/S	76250	94	RSA150	73628	76	RVT6-S/S	76205	101	SACPL-60/1500	77893	91
RCAP-24/600	77921	92	RSA150	73628	78	RVT6-S/S	76205	107	SACPL-60/1500	77893	98
RCAP-24/600-S/S	78363	94	RSA150	73628	92	SAC2-TIP-TL	77866	85	SACPL-60/1500	77893	105
RCAP-30/750	77922	92	RSA150	73628	98	SAC2-TIP-TL	77866	87	SACPL-60/1500-S/S	78377	86
RCAP-30/750-S/S	78364	94	RSA150	73628	105	SAC2-TIP-TL	77866	92	SACPL-60/1500-S/S	78377	93
RCAP-36/900	77923	92	RSA150 (V-Tip)	73628	89	SAC2-TIP-TL	77866	94	SACPL-60/1500-S/S	78377	100
RCAP-36/900-S/S	78365	94	RSA150 (V-Tip)	73628	96	SAC2-TIP-TL	77866	99	SACPL-60/1500-S/S	78377	106
RCAP-42/1050	77924	92	RSA150 (V-Tip)	73628	103	SAC2-TIP-TL	77866	101	SACPL-72/1800	77894	84
RCAP-42/1050-S/S	78366	94	RSA150-EL	61141	69	SAC2-TIP-TL	77866	105	SACPL-72/1800	77894	91
RCAP-48/1200	77925	92	RSA150-EL	61141	71	SAC2-TIP-TL	77866	107	SACPL-72/1800	77894	98
RCAP-48/1200-S/S	78367	94	RSA150-EL	61141	71	SACKRP	77885	48	SACPL-72/1800	77894	105
RCAP-54/1350	77926	92	RV1050	74637	67	SACKRP	77885	85	SACPL-72/1800-S/S	78378	86
RCAP-54/1350-S/S	78368	94	RV1050-S/S	75345	67	SACKRP	77885	92	SACPL-72/1800-S/S	78378	93
RCAP-60/1500	77927	92	RV1050-SAC	78036	89	SACKRP	77885	99	SACPL-72/1800-S/S	78378	100
RCAP-60/1500-S/S	78369	94	RV1050-SAC-S/S	78345	89	SACKRP	77885	105	SACPL-72/1800-S/S	78378	106
RCAP-72/1800	77928	92	RV1200	74638	67	SACKRP-S/S	78399	87	SACPL2-120/3000	77899	84
RCAP-72/1800-S/S	78370	94	RV1200-S/S	75346	67	SACKRP-S/S	78399	94	SACPL2-120/3000	77899	91
RIBBK	81250	137	RV1200-SAC	78037	89	SACKRP-S/S	78399	101	SACPL2-120/3000	77899	98
RIBBK	81250	139	RV1200-SAC-S/S	78346	89	SACKRP-S/S	78399	107	SACPL2-120/3000	77899	105
RIBBK	81250	141	RV1350-SAC	78038	89	SACPL-24/600	77887	84	SACPL2-120/3000-S/S	78383	86
RIBBK	81250	143	RV1350-SAC-S/S	78347	89	SACPL-24/600	77887	91	SACPL2-120/3000-S/S	78383	93
RMC-FS	76558	171	RV1400	74639	67	SACPL-24/600	77887	98	SACPL2-120/3000-S/S	78383	100
RMC1-BPP	76415	171	RV1400-S/S	75347	67	SACPL-24/600	77887	105	SACPL2-120/3000-S/S	78383	106
RMC1-CB	75817	171	RV1500	74640	67	SACPL-24/600-S/S	78371	86	SACPL2-60/1500	77895	84
RMC1-PP	75832	171	RV1500-2SAC	78041	89	SACPL-24/600-S/S	78371	93	SACPL2-60/1500	77895	91
RM2-AP	76559	171	RV1500-2SAC-S/S	78350	89	SACPL-24/600-S/S	78371	100	SACPL2-60/1500	77895	98
RM2-AP-S/S	A2704	171	RV1500-S/S	75348	67	SACPL-24/600-S/S	78371	106	SACPL2-60/1500	77895	105
RP1050	74608	68	RV1500-SAC	78039	89	SACPL-30/750	77888	84	SACPL2-60/1500-S/S	78379	86
RP1050-S/S	75404	68	RV1500-SAC-S/S	78348	89	SACPL-30/750	77888	91	SACPL2-60/1500-S/S	78379	93
RP1200	74609	68	RV1800-2SAC	78042	89	SACPL-30/750	77888	98	SACPL2-60/1500-S/S	78379	100
RP1200-S/S	75405	68	RV1800-2SAC-S/S	78351	89	SACPL-30/750	77888	105	SACPL2-60/1500-S/S	78379	106
RP1400	74610	68	RV1800-SAC	78040	89	SACPL-30/750-S/S	78372	86	SACPL2-72/1800	77896	84
RP1400-S/S	75406	68	RV1800-SAC-S/S	78349	89	SACPL-30/750-S/S	78372	93	SACPL2-72/1800	77896	91
RP1500	74611	68	RV1950-2SAC-S/S	78663	89	SACPL-30/750-S/S	78372	100	SACPL2-72/1800	77896	98
RP1500-S/S	75407	68	RV2100-2SAC	78043	89	SACPL-30/750-S/S	78372	106	SACPL2-72/1800	77896	105
RP450	74604	68	RV2100-2SAC-S/S	78352	89	SACPL-36/900	77889	84	SACPL2-72/1800-S/S	78380	86
RP450-S/S	75400	68	RV2400-2SAC	78044	89	SACPL-36/900	77889	91	SACPL2-72/1800-S/S	78380	93
RP600	74605	68	RV2400-2SAC-S/S	78353	89	SACPL-36/900	77889	98	SACPL2-72/1800-S/S	78380	100
RP600-S/S	75401	68	RV3000-2SAC	78045	89	SACPL-36/900	77889	105	SACPL2-72/1800-S/S	78380	106
RP750	74606	68	RV3000-2SAC-S/S	78354	89	SACPL-36/900-S/S	78373	86	SACPL2-78/1950-S/S	78642	86
RP750-S/S	75402	68	RV450	74633	67	SACPL-36/900-S/S	78373	93	SACPL2-78/1950-S/S	78642	93
RP900	74607	68	RV450-S/S	75341	67	SACPL-36/900-S/S	78373	100	SACPL2-78/1950-S/S	78642	100
RP900-S/S	75403	68	RV600	74634	67	SACPL-36/900-S/S	78373	106	SACPL2-78/1950-S/S	78642	106
RPHD1800	74613	68	RV600-S/S	75342	67	SACPL-42/1050	77890	84	SACPL2-84/2100	77897	84
RPHD1800-S/S	A1575	68	RV600-SAC	78033	89	SACPL-42/1050	77890	91	SACPL2-84/2100	77897	91
RPHD2000	74614	68	RV600-SAC-S/S	78342	89	SACPL-42/1050	77890	98	SACPL2-84/2100	77897	98
RPHD2000-S/S	61270	68	RV750	74635	67	SACPL-42/1050	77890	105	SACPL2-84/2100	77897	105
RPHD2100	A2527	68	RV750-S/S	75343	67	SACPL-42/1050-S/S	78374	86	SACPL2-84/2100-S/S	78381	86
RPHD2100-S/S	A1629	68	RV750-SAC	78034	89	SACPL-42/1050-S/S	78374	93	SACPL2-84/2100-S/S	78381	93
RPHD2400	74615	68	RV750-SAC-S/S	78343	89	SACPL-42/1050-S/S	78374	100	SACPL2-84/2100-S/S	78381	100
RPHD2400-S/S	61271	68	RV900	74636	67	SACPL-42/1050-S/S	78374	106	SACPL2-84/2100-S/S	78381	106
RS-1-15-24-35		174	RV900-S/S	75344	67	SACPL-48/1200	77891	84	SACPL2-96/2400	77898	84

INDEX By Ordering Number

Ordering Number	Item Code	Page #	Ordering Number	Item Code	Page #	Ordering Number	Item Code	Page #	Ordering Number	Item Code	Page #
SACPL2-96/2400	77898	91	SB900-SEC	61065	128	SKPU-8X3/4X50	91225	172	SST1HDM-B	78519	99
SACPL2-96/2400	77898	98	SB900A	A0912	128	SKPU-8X3/8X35	91304	172	SST1HDM-B	78519	117
SACPL2-96/2400	77898	105	SC-7-24		174	SKPU-8X3/8X50	91307	172	SST1HDM-B-S/S	78396	78
SACPL2-96/2400-S/S	78382	86	SC-7-30		174	SKPU-8X5/8X35	91305	172	SST1HDM-B-S/S	78396	101
SACPL2-96/2400-S/S	78382	93	SC-7-36		174	SKPU-8X5/8X50	91308	172	SST1HDM-B-S/S	78396	117
SACPL2-96/2400-S/S	78382	100	SC-7-42		174	SKPU-DUAL-6X1/2X25	91400	171	SST1HDM-G	79069	78
SACPL2-96/2400-S/S	78382	106	SC-7-48		174	SKPU-DUAL-6X1/2X50	91404	171	SST1HDM-G	79069	99
SACRH	77883	48	SC-7-54		174	SKPU-DUAL-6X3/4X25	91401	171	SST1HDM-G	79069	117
SACRH	77883	85	SC-7-60		174	SKPU-DUAL-6X3/4X50	91405	171	SST1HDM-S	78518	78
SACRH	77883	92	SC-7-66		174	SKPU-DUAL-8X1/2X25	91402	171	SST1HDM-S	78518	99
SACRH	77883	99	SC-7-72		174	SKPU-DUAL-8X1/2X50	91406	171	SST1HDM-S	78518	117
SACRH	77883	105	SC-7-84		174	SKPU-DUAL-8X3/4X25	91403	171	SST1HDM-S	78518	118
SACRH-S/S	78397	87	SC-7-96		174	SKPU-DUAL-8X3/4X50	91407	171	SST1HDM-S-S/S	78395	78
SACRH-S/S	78397	94	SCU60	82812	112	SKPUT-12X5/8X50	91327	172	SST1HDM-S-S/S	78395	101
SACRH-S/S	78397	101	SCU60-S/S	82810	113	SMR-CCB-L60	A2844	130	SST1HDM-S-S/S	78395	117
SACRH-S/S	78397	107	SCUHD	82813	112	SMR-CCB-L73	A2842	85	SST1HDM-W	78517	78
SACRHL	77884	48	SCUHD-S/S	82811	113	SMR-CCB-L73	A2842	92	SST1HDM-W	78517	99
SACRHL	77884	85	SHIM-KITH	77550	147	SMR-CCB-L73	A2842	105	SST1HDM-W	78517	117
SACRHL	77884	92	SHIM-KITL	77548	145	SMR-CCB-L73	A2842	130	SST1HDM-W-S/S	78394	78
SACRHL	77884	99	SHIM-KITM	77549	146	SMR-CCB-R60	A2845	130	SST1HDM-W-S/S	78394	101
SACRHL	77884	105	SHIM-LDKIT	82393	137	SMR-CCB-R73	A2843	85	SST1HDM-W-S/S	78394	117
SACRHL-S/S	78398	87	SHIM-LDKIT	82393	139	SMR-CCB-R73	A2843	92	SSTBK-B	76637	78
SACRHL-S/S	78398	94	SHIM-LDKIT	82393	141	SMR-CCB-R73	A2843	105	SSTBK-B	76637	78
SACRHL-S/S	78398	101	SHIM-MDKIT	82394	143	SMR-CCB-R73	A2843	130	SSTBK-B	76637	99
SACRHL-S/S	78398	107	SKPU-10X1/2X25	91311	172	SP-24		175	SSTBK-B	76637	101
SACRKN	77882	48	SKPU-10X1/2X50	91316	172	SP-48		175	SSTBK-B	76637	117
SACRKN	77882	85	SKPU-10X1X25	91314	172	SP-72		175	SSTBK-B	76637	117
SACRKN	77882	87	SKPU-10X1X50	91319	172	SP-96		175	SSTBK-W	76636	78
SACRKN	77882	92	SKPU-10X3/4X25	91313	172	SPFC	79200	73	SSTBK-W	76636	78
SACRKN	77882	94	SKPU-10X3/4X50	91318	172	SPFC	79200	76	SSTBK-W	76636	99
SACRKN	77882	99	SKPU-10X3/8X25	91310	172	SPFC	79200	78	SSTBK-W	76636	101
SACRKN	77882	101	SKPU-10X3/8X50	91315	172	SPFC	79200	98	SSTBK-W	76636	117
SACRKN	77882	105	SKPU-10X5/8X25	91312	172	SPFC	79200	105	SSTBK-W	76636	117
SACRKN	77882	107	SKPU-10X5/8X50	91317	172	SPFC-S/S	79201	73	SSTBK-W	76636	118
SACRKT	77886	85	SKPU-12X1/2X25	91321	172	SPFC-S/S	79201	76	SSTHDMK	77870	78
SACRKT	77886	92	SKPU-12X1/2X50	91326	172	SPFC-S/S	79201	78	SSTHDMK	77870	98
SACRKT	77886	99	SKPU-12X1X35	91234	172	SPFC-S/S	79201	101	SSTHDMK	77870	117
SACRKT	77886	105	SKPU-12X1X50	91329	172	SPFC-S/S	79201	107	SSTHDPM	77868	78
SACRKT-S/S	78401	87	SKPU-12X3/4/50	91328	172	SPG-CVR-A	77387	22	SSTHDPM	77868	99
SACRKT-S/S	78401	94	SKPU-12X3/4X25	91323	172	SPG-CVR-A	77387	81	SSTHDPM	77868	117
SACRKT-S/S	78401	101	SKPU-12X3/8X25	91320	172	SPG-CVR-A	77387	109	SSTHK	79070	78
SACRKT-S/S	78401	107	SKPU-12X3/8X50	91325	172	SPG-CVR-B	77388	22	SSTHK	79070	117
SACSK	77052	99	SKPU-12X5/8X25	91322	172	SPG-CVR-B	77388	81	SSTHK-S/S	79071	78
SACSK	77052	101	SKPU-4X1/2X25	91289	172	SPG-CVR-B	77388	109	SSTHK-S/S	79071	117
SACSRC	77065	99	SKPU-4X1/2X50	91294	172	SPG-CVR-C	77389	22	SSTLMB	76072	134
SACSRC	77065	101	SKPU-4X1X25	91292	172	SPG-CVR-C	77389	81	SSTLMB	76071	134
SB1050-SEC	61066	128	SKPU-4X1X50	91297	172	SPG-CVR-C	77389	109	STAK	75847	78
SB1050A	A0435	128	SKPU-4X3/4X25	91291	172	SPG-CVR-D	77390	22	STAK	75847	78
SB1200-SEC	61067	128	SKPU-4X3/4X50	91296	172	SPG-CVR-D	77390	81	STAK	75847	99
SB1200A	A0316	128	SKPU-4X3/8X25	91288	172	SPG-CVR-D	77390	109	STAK	75847	101
SB1400-SEC	61068	128	SKPU-4X3/8X50	91293	172	SPG-CVR-E	77391	22	STAK	75847	117
SB1400A	A1620	128	SKPU-4X5/8X25	91290	172	SPG-CVR-E	77391	81	STAK	75847	117
SB1500-SEC	61069	128	SKPU-4X5/8X50	91295	172	SPG-CVR-E	77391	109	STAKHD	75892	78
SB1500A	A1838	128	SKPU-6x1/2x25	90283	172	SPG-CVR-F	77392	22	STAKHD	75892	78
SB1800-SEC	61070	128	SKPU-6x1/2x25	90285	172	SPG-CVR-F	77392	81	STAKHD	75892	99
SB1800A	A1357	128	SKPU-6X1/2X50	91222	172	SPG-CVR-F	77392	109	STAKHD	75892	101
SB4	78789	137	SKPU-6X1X25	91300	172	SPG-CVR-G	77393	22	STAKHD	75892	117
SB4	78789	139	SKPU-6X1X50	91303	172	SPG-CVR-G	77393	81	STAKHD	75892	117
SB4	78789	141	SKPU-6x3/4x25	90284	172	SPG-CVR-G	77393	109	STCK	74506	42
SB4	78789	143	SKPU-6X3/4X50	91223	172	SPG-CVR-H	77741	22	STCK-S/S	75425	42
SB5	78790	137	SKPU-6X3/8X25	91298	172	SPG-CVR-H	77741	81	STGK2	77635	78
SB5	78790	139	SKPU-6X3/8X50	91301	172	SPG-CVR-H	77741	109	STGK2	77635	78
SB5	78790	141	SKPU-6X5/8X25	91299	172	SRBK	74941	133	STGK2	77635	99
SB5	78790	143	SKPU-6X5/8X50	91302	172	SSFRB	78456	32	STGK2	77635	101
SB600-SEC	61063	128	SKPU-8X1X25	91306	172	SSFRB	78456	35	STGK2	77635	117
SB600A	A0887	128	SKPU-8X1X50	91224	172	SSRB	75978	32	STGK2	77635	117
SB750-SEC	61064	128	SKPU-8X1X50	91309	172	SSRB	75978	35	STHDMK2-S/S	77634	78
SB750A	A0407	128	SKPU-8x3/4x25	90286	172	SST1HDM-B	78519	78	STHDMK2-S/S	77634	101

INDEX By Ordering Number

Ordering Number	Item Code	Page #	Ordering Number	Item Code	Page #	Ordering Number	Item Code	Page #	Ordering Number	Item Code	Page #
STHDMK2-S/S	77634	117	STS-W-S/S	77630	73	UHPB	76787	112	URVB60/1500	76743	111
STHDPM2-S/S	77633	78	STS-W-S/S	77630	78	UHPB	76787	113	URVB60/1500	76743	111
STHDPM2-S/S	77633	101	STS-W-S/S	77630	101	UHPB2	79207	112	URVB60/1500	76743	114
STHDPM2-S/S	77633	117	STS-W-S/S	77630	117	UHPB2	79207	113	URVB64/1600	77315	110
STJ-S/S	75426	113	STS-W-S/S	77630	117	UHSPK-M	82887	112	URVB64/1600	77315	110
STJK	74417	42	STTS	74419	42	UHSPK-SS-M	82889	113	URVB64/1600	77315	111
STJK	74417	42	STTS	74419	112	UMBK-M	82890	112	URVB64/1600	77315	111
STJK-S/S	74417	112	STTS-S/S	75585	113	UMBK-SS-M	82891	113	URVB64/1600	77315	114
STJK-S/S	74417	113	TEN-LOCK-KIT	77443	22	UNB60	61369	42	URVB72/1800	76744	110
STJM	74775	42	TEN-LOCK-KIT	77443	81	UNB73	A2671	42	URVB72/1800	76744	110
STJM	74775	42	TEN-LOCK-KIT	77443	109	URCB18/450	76748	114	URVB72/1800	76744	111
STJM	74775	112	TRB18	76485	23	URCB24/600	76749	114	URVB72/1800	76744	111
STJM-S/S	75426	42	TRB18	76485	25	URCB30/750	76750	114	URVB72/1800	76744	114
STJM-S/S	75426	42	TRB18	76485	27	URCB36/900	76751	114	URVB80/2000	77320	110
STKD	74504	42	TRB24	76486	23	URCB42/1050	76752	114	URVB80/2000	77320	110
STKD-S/S	75427	42	TRB24	76486	25	URCB48/1200	76753	114	URVB80/2000	77320	111
STLP	79535	122	TRB24	76486	27	URCB54/1350	76754	114	URVB80/2000	77320	111
STS-B	75844	43	TRB30	76487	23	URCB56/1400	77317	114	URVB80/2000	77320	114
STS-B	75844	43	TRB30	76487	25	URCB60/1500	76755	114	URVB84/2100	76745	110
STS-B	75844	63	TRB30	76487	27	URCB64/1600	77318	114	URVB84/2100	76745	110
STS-B	75844	71	TRB36	76488	23	URCB72/1800	76756	114	URVB84/2100	76745	111
STS-B	75844	73	TRB36	76488	25	URCB80/2000	77321	114	URVB84/2100	76745	111
STS-B	75844	78	TRB36	76488	27	URCB84/2100	76757	114	URVB84/2100	76745	114
STS-B	75844	99	TRB42	76489	23	URCB88/2200	76319	114	URVB88/2200	77316	110
STS-B	75844	117	TRB42	76489	25	URCB94/2400	77448	114	URVB88/2200	77316	110
STS-B	75844	117	TRB42	76489	27	URCB98/2500	77449	114	URVB88/2200	77316	111
STS-B-S/S	77632	43	TRB48	76490	23	URVB18/450	76736	110	URVB88/2200	77316	111
STS-B-S/S	77632	43	TRB48	76490	25	URVB18/450	76736	110	URVB88/2200	77316	114
STS-B-S/S	77632	71	TRB48	76490	27	URVB18/450	76736	111	URVB94/2400	77421	110
STS-B-S/S	77632	73	TRB54	76491	23	URVB18/450	76736	111	URVB94/2400	77421	110
STS-B-S/S	77632	78	TRB54	76491	25	URVB18/450	76736	114	URVB94/2400	77421	111
STS-B-S/S	77632	101	TRB54	76491	27	URVB24/600	76737	110	URVB94/2400	77421	111
STS-B-S/S	77632	117	TRB60	76492	23	URVB24/600	76737	110	URVB94/2400	77421	114
STS-B-S/S	77632	117	TRB60	76492	25	URVB24/600	76737	111	URVB98/2500	77422	110
STS-G	78142	43	TRB60	76492	27	URVB24/600	76737	111	URVB98/2500	77422	110
STS-G	78142	43	TRB66	76493	23	URVB24/600	76737	114	URVB98/2500	77422	111
STS-G	78142	71	TRB66	76493	25	URVB30/750	76738	110	URVB98/2500	77422	111
STS-G	78142	73	TRB66	76493	27	URVB30/750	76738	110	URVB98/2500	77422	114
STS-G	78142	78	TRB72	76494	23	URVB30/750	76738	111	USP18/450	82689	112
STS-G	78142	99	TRB72	76494	25	URVB30/750	76738	111	USP18/450-S/S	77339	113
STS-G	78142	117	TRB72	76494	27	URVB30/750	76738	114	USP24/600	82690	112
STS-G	78142	117	TRB78	76697	23	URVB36/900	76739	110	USP24/600-S/S	77340	113
STS-G-S/S	79057	43	TRB78	76697	25	URVB36/900	76739	110	USP30/750	82691	112
STS-G-S/S	79057	43	TRB78	76697	27	URVB36/900	76739	111	USP30/750-S/S	77341	113
STS-G-S/S	79057	71	TRB84	77047	25	URVB36/900	76739	111	USP36/900	82692	112
STS-G-S/S	79057	73	TRB84	77047	27	URVB36/900	76739	114	USP36/900-S/S	77342	113
STS-G-S/S	79057	117	TRB90	77048	25	URVB42/1050	76740	110	USP42/1050	82693	112
STS-S	75843	63	TRB90	77048	27	URVB42/1050	76740	110	USP42/1050-S/S	77343	113
STS-S	75843	71	UFB18	74448	114	URVB42/1050	76740	111	USP48/1200	82694	112
STS-S	75843	73	UFB18-B	67327	114	URVB42/1050	76740	111	USP48/1200-S/S	77344	113
STS-S	75843	78	UFB24	74449	114	URVB42/1050	76740	114	USP54/1350	82695	112
STS-S	75843	99	UFB24-B	67328	114	URVB48/1200	76741	110	USP54/1350-S/S	77345	113
STS-S	75843	117	UFB30	74450	114	URVB48/1200	76741	110	USP56/1400	82696	112
STS-S	75843	117	UFB30-B	67329	114	URVB48/1200	76741	111	USP56/1400-S/S	77346	113
STS-S	75843	118	UFB36	74451	114	URVB48/1200	76741	111	USP60/1500	82697	112
STS-S-S/S	77631	71	UFB36-B	67330	114	URVB48/1200	76741	114	USP60/1500-S/S	77347	113
STS-S-S/S	77631	73	UFB42	74452	114	URVB54/1350	76742	110	USP64/1600	82698	112
STS-S-S/S	77631	78	UFB42-B	67331	114	URVB54/1350	76742	110	USP64/1600-S/S	77348	113
STS-S-S/S	77631	101	UFB48	74453	114	URVB54/1350	76742	111	USP72/1800	82699	112
STS-S-S/S	77631	117	UFB48-B	67332	114	URVB54/1350	76742	111	USP72/1800-S/S	77349	113
STS-S-S/S	77631	117	UFB54	74454	114	URVB54/1350	76742	114	USP80/2000	82700	112
STS-W	75846	71	UFB54-B	67333	114	URVB56/1400	77314	110	USP80/2000-S/S	77350	113
STS-W	75846	73	UFB60	74455	114	URVB56/1400	77314	110	USP84/2100	82701	112
STS-W	75846	78	UFB60-B	67334	114	URVB56/1400	77314	111	USP84/2100-S/S	77351	113
STS-W	75846	99	UFB72	74456	114	URVB56/1400	77314	111	USP88/2200	82702	112
STS-W	75846	117	UFB72-B	67335	114	URVB56/1400	77314	114	USP88/2200-S/S	77352	113
STS-W	75846	117	UFB84	74460	114	URVB60/1500	76743	110	USP94/2400	82703	112
STS-W-S/S	77630	71	UFB84-B	67336	114	URVB60/1500	76743	110	USP94/2400-S/S	77419	113

INDEX By Ordering Number

Ordering Number	Item Code	Page #	Ordering Number	Item Code	Page #	Ordering Number	Item Code	Page #	Ordering Number	Item Code	Page #
USP98/2500	82704	112	UTV450J-S/S	77259	111	YSTANK	79858	63	YTCHD-1050	83100	57
USP98/2500-S/S	77420	113	UTV600	77298	110	YSTDBK	79844	62	YTCHD-1200	83101	57
USPB	79206	112	UTV600-J	77284	111	YSTGBK	79845	62	YTCHD-1350	83102	57
USPB	79206	113	UTV600-S/S	82708	110	YSTHD-BK	79842	63	YTCHD-1500	83103	57
USPB2	79206	112	UTV600J-S/S	77260	111	YSTHD-BL	79841	63	YTCHD-1800	83105	57
USPB2	79206	113	UTV750	77299	110	YSTHD-GR	79839	63	YTCHD-900	83099	57
USPK	76790	112	UTV750-J	77285	111	YSTHD-S	79840	63	YTCHD1050-BT-S/S		
USPK-SS-M	82888	113	UTV750-S/S	82709	110	YSTHDBK-B	79856	63	SECONDARY	67291	58
UST-G-MT	82900	112	UTV750J-S/S	77261	111	YSTHDBK-W	79853	63	YTCHD1050-MST-S/S		
UST-G-MT-SS	82904	113	UTV900	77300	110	YSTHDDBK	79850	63	SECONDARY	67309	58
UST-P-MT	82897	112	UTV900-J	77286	111	YSTHDGBK	79851	63	YTCHD1200-BT-S/S		
UST-P-MT-SS	82901	113	UTV900-S/S	82710	110	YSTHDLBK	79852	63	SECONDARY	67292	58
UST-S-MT	82898	112	UTV900J-S/S	77262	111	YSTHDMB	79849	63	YTCHD1200-MST-S/S		
UST-S-MT-SS	82902	113	WCB	A0012	128	YSTHDS-BL	79798	63	SECONDARY	67310	58
UST-W-MT	82899	112	WCB	A0012	129	YSTHDS-GR	79797	63	YTCHD1350-BT-S/S		
UST-W-MT-SS	82903	113	YCART-18/450-P	79617	59	YSTLBK	79846	62	SECONDARY	67293	58
UTS	74420	42	YCART-18/450-TC	79811	59	YSTMB	79843	62	YTCHD1350-MST-S/S		
UTV1050	77301	110	YCART-24/600-P	79618	59	YSTPHDMK	79854	63	SECONDARY	67311	58
UTV1050-J	77287	111	YCART-24/600-TC	79812	59	YSTPMK	79848	62	YTCHD1500-BT-S/S		
UTV1050-S/S	82711	110	YCART-30/750-P	79619	59	YSTS-P	79796	62	SECONDARY	67294	58
UTV1050J-S/S	77263	111	YCART-30/750-TC	79813	59	YSTS-Y	79795	62	YTCHD1500-MST-S/S		
UTV1200	77302	110	YCART-36/900-HDP	79817	59	YSTTBK-B	79855	62	SECONDARY	67312	58
UTV1200-J	77288	111	YCART-36/900-HDTC	79829	59	YSTTBK-W	79847	62	YTCHD1800-BT-S/S		
UTV1200-S/S	82712	110	YCART-36/900-P	79620	59	YT-1050S	83233	56	SECONDARY	67295	58
UTV1200J-S/S	77264	111	YCART-36/900-TC	79814	59	YT-1200S	83234	56	YTCHD1800-MST-S/S		
UTV1350	77303	110	YCART-42/1050-HDP	79818	59	YT-450S	83229	56	SECONDARY	67313	58
UTV1350-J	77289	111	YCART-42/1050-HDTC	79830	59	YT-600S	83230	56	YTCHD900-BT-S/S		
UTV1350-S/S	82713	110	YCART-42/1050-P	79621	59	YT-750S	83231	56	SECONDARY	67290	58
UTV1350J-S/S	77265	111	YCART-42/1050-TC	79815	59	YT-900S	83232	56	YTCHD900-MST-S/S		
UTV1400	77304	110	YCART-48/1200-HDP	79819	59	YT-C	79574	59	SECONDARY	67308	58
UTV1400-J	77290	111	YCART-48/1200-HDTC	79831	59	YT-HDC	79728	59	YTFHD1050-MST-S/S		
UTV1400-S/S	82714	110	YCART-48/1200-P	79622	59	YT-HDP	79677	59	SECONDARY	67315	58
UTV1400J-S/S	77266	111	YCART-48/1200-TC	79816	59	YT-P	79573	59	YTFHD1200-MST-S/S		
UTV1500	77305	110	YCART-54/1350-HDP	79820	59	YT-TC-1050S	83245	56	SECONDARY	67316	58
UTV1500-J	77291	111	YCART-54/1350-HDTC	79832	59	YT-TC-1200S	83246	56	YTFHD1350-MST-S/S		
UTV1500-S/S	82715	110	YCART-60/1500-HDP	79821	59	YT-TC-450S	83241	56	SECONDARY	67317	58
UTV1500J-S/S	77267	111	YCART-60/1500-HDTC	79833	59	YT-TC-600S	83242	56	YTFHD1500-MST-S/S		
UTV1600	77306	110	YCART-72/1800-HDP	79822	59	YT-TC-750S	83243	56	SECONDARY	67318	58
UTV1600-J	77292	111	YCART-72/1800-HDTC	79834	59	YT-TC-900S	83244	56	YTFHD1800-MST-S/S		
UTV1600-S/S	82716	110	YCART-S/S-24/600-SDTC	66749	64	YTA-18/450	82949	62	SECONDARY	67319	58
UTV1600J-S/S	77268	111	YCART-S/S-30/750-SDTC	67750	64	YTA-24/600	82950	62	YTFHD900-MST-S/S		
UTV1800	77307	110	YCART-S/S-36/900-HDP	67417	64	YTA-30/750	82951	62	SECONDARY	67314	58
UTV1800-J	77293	111	YCART-S/S-36/900-HDTC	67411	64	YTA-36/900	82952	62	YTFHD1500-MST-S/S		
UTV1800-S/S	82717	110	YCART-S/S-36/900-SDTC	67751	64	YTA-42/1050	82953	62	SECONDARY	67315	58
UTV1800J-S/S	77269	111	YCART-S/S-42/1050-HDP	67418	64	YTA-48/1200	82954	62	YTFHD1800-MST-S/S		
UTV2000	77308	110	YCART-S/S-42/1050-HDTC	67412	64	YTAC	79623	62	SECONDARY	67316	58
UTV2000-J	77294	111	YCART-S/S-42/1050-SDTC	67752	64	YTACHD	79835	63	YTHD-1050S	83121	57
UTV2000-S/S	82718	110	YCART-S/S-48/1200-HDP	67419	64	YTAHD-36/900	79805	63	YTHD-1200S	83122	57
UTV2000J-S/S	77270	111	YCART-S/S-48/1200-HDTC	67413	64	YTAHD-42/1050	79806	63	YTHD-1350S	83123	57
UTV2100	77309	110	YCART-S/S-48/1200-SDTC	67753	64	YTAHD-48/1200	79807	63	YTHD-1500S	83124	57
UTV2100-J	77295	111	YCART-S/S-54/1350-HDP	67420	64	YTAHD-54/1350	79808	63	YTHD-1800S	83126	57
UTV2100-S/S	82719	110	YCART-S/S-54/1350-HDTC	67414	64	YTAHD-60/1500	79809	63	YTHD-900S	83120	57
UTV2100J-S/S	77271	111	YCART-S/S-60/1500-HDP	67421	64	YTAHD-72/1800	79810	63	YTHD-TC-1050S	83135	57
UTV2200	77310	110	YCART-S/S-60/1500-HDTC	67415	64	YTC-1050	83227	56	YTHD-TC-1200S	83136	57
UTV2200-J	77296	111	YCART-S/S-72/1800-HDP	67422	64	YTC-1200	83228	56	YTHD-TC-1350S	83137	57
UTV2200-S/S	82720	110	YCART-S/S-72/1800-HDTC	67416	64	YTC-450	83223	56	YTHD-TC-1500S	83138	57
UTV2200J-S/S	77272	111	YPHD1050-S/S POLE	64199	64	YTC-600	83224	56	YTHD-TC-1800S	83140	57
UTV2400	77411	110	YPHD1200-S/S POLE	64200	64	YTC-750	83225	56	YTHD-TC-900S	83134	57
UTV2400-J	77413	111	YPHD1350-S/S POLE	64201	64	YTC-900	83226	56	YTP-18/450	82932	62
UTV2400-S/S	82721	110	YPHD1500-S/S POLE	64202	64	YTC1050-BT-S/S			YTP-24/600	82933	62
UTV2400J-S/S	77417	111	YPHD1800-S/S POLE	64204	64	SECONDARY	67288	58	YTP-30/750	82934	62
UTV2500	77412	110	YPHD600-S/S POLE	67322	64	YTC1200-BT-S/S			YTP-36/900	82935	62
UTV2500-J	77414	111	YPHD750-S/S POLE	67323	64	SECONDARY	67289	58	YTP-42/1050	82936	62
UTV2500-S/S	82722	110	YPHD900-S/S POLE	64198	64	YTC600-BT-S/S			YTP-48/1200	82937	62
UTV2500J-S/S	77418	111	YST-P	79837	62	SECONDARY	67285	58	YTPHD-36/900	83106	63
UTV450	77297	110	YST-S	79838	62	YTC750-BT-S/S			YTPHD-42/1050	83107	63
UTV450-J	77283	111	YST-Y	79836	62	SECONDARY	67286	58	YTPHD-48/1200	83108	63
UTV450-S/S	82707	110	YSTANK	79857	62	YTC900-BT-S/S			YTPHD-54/1350	83109	63
						SECONDARY	67287	58	YTPHD-60/1500	83110	63
									YTPHD-72/1800	83112	63
										67325	64
										64205	64
										64206	64
										64207	64
										64205	64
										64206	64

INDEX By Ordering Number

Ordering Number	Item Code	Page #	Ordering Number	Item Code	Page #	Ordering Number	Item Code	Page #	Ordering Number	Item Code	Page #
	64207	64									
	64208	64									
	64209	64									
	64211	64									
	GR298	64									
	B0536	64									

INDEX By Item Code

Item Code	Ordering Number	Page #	Item Code	Ordering Number	Page #	Item Code	Ordering Number	Page #	Item Code	Ordering Number	Page #
26107	N6D3T-24-9-A45	137	61113	CBD-ST-L-FP	157	61751	FBP1050-TP	154	61908	FBP1500-1600-SP	155
26108	N6D3T-30-11-A45	137	61114	CBD-ST-XL-FP	157	61752	FBP1200-TP	154	61909	FBP1800-2000-SP	155
26109	N6D3T-36-13-A45	137	61141	RSA150-EL	69	61753	FBP1400-TP	154	61910	FBP2200-2400-SP	155
26110	N6D3T-42-15-A45	137	61141	RSA150-EL	71	61754	FBP1500-TP	154	61911	FBP2500-2600-SP	155
26111	N6D3T-48-17-A45	137	61141	RSA150-EL	71	61755	FBP1600-TP	154	61914	FBP900-1050-SP-S/S	155
26112	N6D3T-54-19-A45	137	61173	HSTSS	42	61756	FBP1800-TP	154	61915	FBP1200-1400-SP-S/S	155
26113	N6D3T-60-21-A45	137	61182	EZP1P18-S/S	18	61757	FBP2000-TP	154	61916	FBP1500-1600-SP-S/S	155
26114	N6D3T-72-25-A45	137	61183	EZP1P42-S/S	18	61758	FBP2200-TP	154	61917	FBP1800-2000-SP-S/S	155
26184	NI6D3T-24-9-A45	139	61184	EZP1P54-S/S	18	61759	FBP2400-TP	154	61918	FBP2200-2400-SP-S/S	155
26185	NI6D3T-30-11-A45	139	61185	EZP1P60-S/S	18	61760	FBP2500-TP	154	61919	FBP2500-2600-SP-S/S	155
26186	NI6D3T-36-13-A45	139	61186	EZP1P72-S/S	18	61761	FBP2600-TP	154	62034	AIR HDMRK S/S	43
26187	NI6D3T-42-15-A45	139	61270	RPHD2000-S/S	68	61765	FBP900-TP S/S	154	62035	AIR HARK-S/S-60	43
26188	NI6D3T-48-17-A45	139	61271	RPHD2400-S/S	68	61766	FBP1050-TP S/S	154	62036	AIR BAG P	43
26189	NI6D3T-54-19-A45	139	61356	PBC-1	176	61767	FBP1200-TP S/S	154	62036	ATV-BAG	74
26190	NI6D3T-60-21-A45	139	61357	PBC-2	176	61768	FBP1400-TP S/S	154	62037	ATV-NIP	43
26191	NI6D3T-72-25-A45	139	61358	PBC-FR	176	61769	FBP1500-TP S/S	154	62037	ATV-NIP	74
28250	RBPSR-S-CCT	159	61369	UNB60	42	61770	FBP1600-TP S/S	154	62037	ATV-NIP	79
28251	RBPSR-M-CCT	159	61471	FLSCM2000-S/S	170	61771	FBP1800-TP S/S	154	62037	ATV-NIP	99
28253	RBPSR-L-CCT	159	61491	EZP1P48-S/S	18	61772	FBP2000-TP S/S	154	62079	ATV-BAG	79
28254	RBPSR-XL-CCT	159	61504	MHCP-600S-S/S	33	61773	FBP2200-TP S/S	154	62079	ATV-BAG	99
30001	EBC-1	176	61505	MHCP-750S-S/S	33	61774	FBP2400-TP S/S	154	62095	CRHMK-S/S	87
30002	EBC-2	176	61506	MHCP-900S-S/S	33	61775	FBP2500-TP S/S	154	62095	CRHMK-S/S	94
30003	EBC-1-B	176	61507	MHCP-1050S-S/S	33	61776	FBP2600-TP S/S	154	62095	CRHMK-S/S	107
30004	EBC-2-B	176	61508	MHCP-1200S-S/S	33	61780	FBP900-B	154	62254	HVT8-EL15-S/S	54
30018	CEBC-1	176	61509	MHCP-1350S-S/S	33	61781	FBP1050-B	154	62350	PSR-S-F	158
30019	CEBC-2	176	61510	MHCP-1500S-S/S	33	61782	FBP1200-B	154	62351	PSR-M-F	158
30033	EBC1-RK	176	61511	MHCP-1650S-S/S	33	61783	FBP1400-B	154	62352	PSR-L-F	158
30034	EBC2-RK	176	61512	MHCP-1800S-S/S	33	61784	FBP1500-B	154	62353	PSR-XL-F	158
61001	HDPHSC-S/S	66	61513	MHCP-2100S-S/S	33	61785	FBP1600-B	154	62400	CRHMK	85
61001	HDPHSC-S/S	87	61525	MHCP-S/S-CP 750	35	61786	FBP1800-B	154	62400	CRHMK	92
61003	70A	66	61526	MHCP-S/S-CP 900	35	61787	FBP2000-B	154	62400	CRHMK	105
61003	70A	85	61527	MHCP-S/S-CP 1050	35	61788	FBP2200-B	154	62409	ATVK-60	74
61016	EZP1-242-S/S	15	61528	MHCP-S/S-CP 1200	35	61789	FBP2400-B	154	62409	ATVK-60	79
61017	EZP1-230-S/S	15	61529	MHCP-S/S-CP 1350	35	61790	FBP2500-B	154	62409	ATVK-60	99
61050	CBD-ST-L	157	61530	MHCP-S/S-CP 1500	35	61791	FBP2600-B	154	62424	ATV-MOUNT	74
61051	CBD-ST-XL	157	61531	MHCP-S/S-CP 1650	35	61795	FBP900-1050-MF	155	62424	ATV-MOUNT	79
61063	SB600-SEC	128	61532	MHCP-S/S-CP 1800	35	61796	FBP1200-1400-MF	155	62424	ATV-MOUNT	99
61064	SB750-SEC	128	61533	MHCP-S/S-CP 2100	35	61797	FBP1500-1600-MF	155	62425	ATV-SLIDE	74
61065	SB900-SEC	128	61534	MHCP-SS/EP	35	61798	FBP1800-2000-MF	155	62425	ATV-SLIDE	79
61066	SB1050-SEC	128	61535	MHCP-S/S-CK600	35	61799	FBP2200-2400-MF	155	62425	ATV-SLIDE	99
61067	SB1200-SEC	128	61536	MHCP-S/S-CK750	35	61800	FBP2500-2600-MF	155	62426	ATV-ANGLE	74
61068	SB1400-SEC	128	61537	MHCP-S/S-CK900	35	61803	FBP900-1050-MF-S/S	155	62426	ATV-ANGLE	79
61069	SB1500-SEC	128	61538	MHCP-S/S-CK1050	35	61804	FBP1200-1400-MF-S/S	155	62426	ATV-ANGLE	99
61070	SB1800-SEC	128	61539	MHCP-S/S-CK1200	35	61805	FBP1500-1600-MF-S/S	155	62452	H-SAC-AP-600	48
61073	PMR-CHB-L60	130	61540	MHCP-S/S-CK1350	35	61806	FBP1800-2000-MF-S/S	155	62452	H-SAC-AP-600	49
61074	PMR-CHB-R60	130	61541	MHCP-S/S-CK1500	35	61807	FBP2200-2400-MF-S/S	155	62452	H-SAC-AP-600	49
61075	PMR-CHB-L73	130	61542	MHCP-S/S-CK1650	35	61808	FBP2500-2600-MF-S/S	155	62452	H-SAC-AP-600	49
61076	PMR-CHB-R73	130	61543	MHCP-S/S-CK1800	35	61875	FBP-NP	155	62452	H-SAC-AP-600	54
61077	CBD-ST-M	157	61544	MHCP-S/S-CK2100	35	61876	FBP-NP-S/S	155	62452	H-SAC-AP-600	55
61079	CBD-ST-M-S/S	157	61545	MHCP-S/S-CLP	35	61877	HBP2600-PL-TP-S/S	155	62452	H-SAC-AP-600	55
61080	CBD-ST-L-S/S	157	61546	MHCP-S/S-PSTW	35	61882	FBP-LM	155	62452	H-SAC-AP-600	55
61081	EZP1-218-S/S	15	61547	MHCP-S/S-PSTS	35	61883	FBP-LM-S/S	155	62453	H-SAC-AP-800	48
61082	EZP1-224-S/S	15	61548	MHCP-S/S-CH	35	61888	FBP-FP	155	62453	H-SAC-AP-800	49
61083	EZP1-236-S/S	15	61549	MHCP-S/S-CEB	35	61889	FBP-FP-S/S	155	62453	H-SAC-AP-800	49
61084	EZP1-248-S/S	15	61550	MHCP-S/S-CBK	35	61890	FBP900-1050-PP	155	62453	H-SAC-AP-800	49
61085	EZP1-254-S/S	15	61624	MHCP-600S-S/S-FR	33	61891	FBP1200-1400-PP	155	62453	H-SAC-AP-800	49
61086	EZP1-260-S/S	15	61625	MHCP-750S-S/S-FR	33	61892	FBP1500-1600-PP	155	62453	H-SAC-AP-800	54
61087	EZP1-272-S/S	15	61626	MHCP-900S-S/S-FR	33	61893	FBP1800-2000-PP	155	62453	H-SAC-AP-800	55
61096	CBD-ST-AA	157	61627	MHCP-1050S-S/S-FR	33	61894	FBP2200-2400-PP	155	62453	H-SAC-AP-800	55
61100	CBD-ST-HN-S/S	157	61628	MHCP-1200S-S/S-FR	33	61895	FBP2500-2600-PP	155	62453	H-SAC-AP-800	55
61105	CBD-ST-M-MF	157	61629	MHCP-1350S-S/S-FR	33	61898	FBP900-1050-PP-S/S	155	62453	H-SAC-AP-800	55
61106	CBD-ST-L-MF	157	61630	MHCP-1500S-S/S-FR	33	61899	FBP1200-1400-PP-S/S	155	62454	H-SAC-AP-1000	48
61107	CBD-ST-XL-MF	157	61631	MHCP-1650S-S/S-FR	33	61900	FBP1500-1600-PP-S/S	155	62454	H-SAC-AP-1000	49
61108	CBD-ST-M-MF-S/S	157	61632	MHCP-1800S-S/S-FR	33	61901	FBP1800-2000-PP-S/S	155	62454	H-SAC-AP-1000	49
61109	CBD-ST-L-MF-S/S	157	61633	MHCP-2100S-S/S-FR	33	61902	FBP2200-2400-PP-S/S	155	62454	H-SAC-AP-1000	49
61110	CBD-ST-XL-MF-S/S	157	61634	MHCP-S/S-CP 600	35	61903	FBP2500-2600-PP-S/S	155	62454	H-SAC-AP-1000	49
61111	CBD-ST-FR-B	157	61742	FRPU150	66	61906	FBP900-1050-SP	155	62454	H-SAC-AP-1000	54
61112	CBD-ST-M-FP	157	61750	FBP900-TP	154	61907	FBP1200-1400-SP	155	62454	H-SAC-AP-1000	55

INDEX By Item Code

Item Code	Ordering Number	Page #	Item Code	Ordering Number	Page #	Item Code	Ordering Number	Page #	Item Code	Ordering Number	Page #
62454	H-SAC-AP-1000	55	62511	HSA8CL-S/S	48	62568	HV-1800-2SAC-CM	44	62634	HV-800-SAC-CS-S/S	46
62454	H-SAC-AP-1000	55	62511	HSA8CL-S/S	49	62569	HV-1800-2SAC-CL	44	62635	HV-800-SAC-CM-S/S	46
62454	H-SAC-AP-1000	55	62511	HSA8CL-S/S	52	62570	HV-1800-2SAC-CLL	44	62636	HV-800-SAC-CL-S/S	46
62455	H-SAC-AP-1200	48	62511	HSA8CL-S/S	54	62571	HV-2000-2SAC-CM	44	62637	HV-1000-SAC-CS-S/S	46
62455	H-SAC-AP-1200	49	62511	HSA8CL-S/S	55	62572	HV-2000-2SAC-CL	44	62638	HV-1000-SAC-CM-S/S	46
62455	H-SAC-AP-1200	49	62512	HSA8CLL-S/S	46	62573	HV-2000-2SAC-CLL	44	62639	HV-1000-SAC-CL-S/S	46
62455	H-SAC-AP-1200	49	62512	HSA8CLL-S/S	48	62574	HV-2200-2SAC-CM	44	62640	HV-1200-SAC-CS-S/S	46
62455	H-SAC-AP-1200	49	62512	HSA8CLL-S/S	49	62575	HV-2200-2SAC-CL	44	62641	HV-1200-SAC-CM-S/S	46
62455	H-SAC-AP-1200	54	62512	HSA8CLL-S/S	52	62576	HV-2200-2SAC-CLL	44	62642	HV-1200-SAC-CL-S/S	46
62455	H-SAC-AP-1200	55	62512	HSA8CLL-S/S	54	62577	HV-2400-2SAC-CM	44	62643	HV-1400-SAC-CS-S/S	46
62455	H-SAC-AP-1200	55	62512	HSA8CLL-S/S	55	62578	HV-2400-2SAC-CL	44	62644	HV-1400-SAC-CM-S/S	46
62455	H-SAC-AP-1200	55	62513	HCSBB-60	43	62579	HV-2400-2SAC-CLL	44	62645	HV-1400-SAC-CL-S/S	46
62455	H-SAC-AP-1200	55	62513	HCSBB-60	43	62580	HV-2600-2SAC-CM	44	62646	HV-1600-SAC-CM-S/S	46
62456	H-SAC-AP-1400	48	62514	HCSBB-73	43	62581	HV-2600-2SAC-CL	44	62647	HV-1600-SAC-CL-S/S	46
62456	H-SAC-AP-1400	49	62514	HCSBB-73	43	62582	HV-1600-2SAC-CL-S/S	46	62648	HV-1600-SAC-CLL-S/S	46
62456	H-SAC-AP-1400	49	62515	HV-600-SAC-CS	44	62582	HV-2600-2SAC-CLL	44	62649	HV-1800-SAC-CM-S/S	46
62456	H-SAC-AP-1400	49	62516	HV-600-SAC-CM	44	62583	HV-2800-2SAC-CM	44	62650	HV-1800-SAC-CL-S/S	46
62456	H-SAC-AP-1400	49	62517	HV-600-SAC-CL	44	62584	HV-2800-2SAC-CL	44	62651	HV-1800-SAC-CLL-S/S	46
62456	H-SAC-AP-1400	54	62518	HV-800-SAC-CS	44	62585	HV-2800-2SAC-CLL	44	62652	H CARK-600-CS-S/S	47
62456	H-SAC-AP-1400	55	62519	HV-800-SAC-CM	44	62586	HV-3000-2SAC-CM	44	62653	H CARK-600-CM-S/S	47
62456	H-SAC-AP-1400	55	62520	HV-800-SAC-CL	44	62587	HV-3000-2SAC-CL	44	62654	H CARK-600-CL-S/S	47
62456	H-SAC-AP-1400	55	62521	HV-1000-SAC-CS	44	62588	HV-3000-2SAC-CLL	44	62655	H CARK-800-CS-S/S	47
62456	H-SAC-AP-1400	55	62522	HV-1000-SAC-CM	44	62589	HCSB-B/G	43	62656	H CARK-800-CM-S/S	47
62457	H-SAC-AP-1600	48	62523	HV-1000-SAC-CL	44	62589	HCSB-B/G	43	62657	H CARK-800-CL-S/S	47
62457	H-SAC-AP-1600	49	62524	HV-1200-SAC-CS	44	62589	HCSB-B/G	43	62658	H CARK-1000-CS-S/S	47
62457	H-SAC-AP-1600	54	62525	HV-1200-SAC-CM	44	62589	HCSB-B/G	43	62659	H CARK-1000-CM-S/S	47
62457	H-SAC-AP-1600	55	62526	HV-1200-SAC-CL	44	62590	HCSB-S	43	62660	H CARK-1000-CL-S/S	47
62458	H-SAC-AP-1800	48	62527	HV-1400-SAC-CS	44	62590	HCSB-S	43	62661	H CARK-1200-CS-S/S	47
62458	H-SAC-AP-1800	54	62528	HV-1400-SAC-CM	44	62591	ACME-N	43	62662	H CARK-1200-CM-S/S	47
62494	HCSTAK	43	62529	HV-1400-SAC-CL	44	62591	ACME-N	43	62663	H CARK-1200-CL-S/S	47
62495	HCSTAK-S/S	43	62530	HV-1600-SAC-CM	44	62591	ACME-N	43	62664	H CARK-1400-CS-S/S	47
62496	ACME-PRK	43	62531	HV-1600-SAC-CL	44	62591	ACME-N	43	62665	H CARK-1400-CM-S/S	47
62496	ACME-PRK	43	62532	HV-1600-SAC-CLL	44	62595	DBK-XXL	156	62666	H CARK-1400-CL-S/S	47
62496	ACME-PRK	43	62533	HV-1800-SAC-CM	44	62599	H-CARK2-1200-CS	45	62667	H CARK-1600-CS-S/S	47
62496	ACME-PRK	43	62534	HV-1800-SAC-CL	44	62600	H-CARK2-1200-CM	45	62668	H CARK-1600-CM-S/S	47
62505	HSA8CS	48	62535	HV-1800-SAC-CLL	44	62601	H-CARK2-1200-CL	45	62669	H CARK-1600-CL-S/S	47
62505	HSA8CS	49	62536	H-CARK-600-CS	45	62602	H-CARK2-1200-CLL	45	62670	H CARK-1800-CS-S/S	47
62505	HSA8CS	50	62537	H-CARK-600-CM	45	62603	H-CARK2-1400-CS	45	62671	H CARK-1800-CM-S/S	47
62505	HSA8CS	54	62538	H-CARK-600-CL	45	62604	H-CARK2-1400-CM	45	62672	H CARK-1800-CL-S/S	47
62505	HSA8CS	55	62539	H-CARK-800-CS	45	62605	H-CARK2-1400-CL	45	62673	HV-1200-2SAC-CS-S/S	46
62506	HSA8CM	48	62540	H-CARK-800-CM	45	62606	H-CARK2-1400-CLL	45	62674	HV-1200-2SAC-CM-S/S	46
62506	HSA8CM	49	62541	H-CARK-800-CL	45	62607	H-CARK2-1600-CM	45	62675	HV-1200-2SAC-CL-S/S	46
62506	HSA8CM	50	62542	H-CARK-1000-CS	45	62608	H-CARK2-1600-CL	45	62676	HV-1200-2SAC-CLL-S/S	46
62506	HSA8CM	54	62543	H-CARK-1000-CM	45	62609	H-CARK2-1600-CLL	45	62677	HV-1400-2SAC-CS-S/S	46
62506	HSA8CM	55	62544	H-CARK-1000-CL	45	62610	H-CARK2-1800-CM	45	62678	HV-1400-2SAC-CM-S/S	46
62507	HSA8CL	48	62545	H-CARK-1200-CS	45	62611	H-CARK2-1800-CL	45	62679	HV-1400-2SAC-CL-S/S	46
62507	HSA8CL	49	62546	H-CARK-1200-CM	45	62612	H-CARK2-1800-CLL	45	62680	HV-1400-2SAC-CLL-S/S	46
62507	HSA8CL	50	62547	H-CARK-1200-CL	45	62613	H-CARK2-2000-CM	45	62681	HV-1600-2SAC-CM-S/S	46
62507	HSA8CL	54	62548	H-CARK-1400-CS	45	62614	H-CARK2-2000-CL	45	62683	HV-1600-2SAC-CLL-S/S	46
62507	HSA8CL	55	62549	H-CARK-1400-CM	45	62615	H-CARK2-2000-CLL	45	62684	HV-1800-2SAC-CM-S/S	46
62508	HSA8CLL	48	62550	H-CARK-1400-CL	45	62616	H-CARK2-2200-CM	45	62685	HV-1800-2SAC-CL-S/S	46
62508	HSA8CLL	49	62551	H-CARK-1600-CS	45	62617	H-CARK2-2200-CL	45	62686	HV-1800-2SAC-CLL-S/S	46
62508	HSA8CLL	50	62552	H-CARK-1600-CM	45	62618	H-CARK2-2200-CLL	45	62687	HV-2000-2SAC-CM-S/S	46
62508	HSA8CLL	54	62553	H-CARK-1600-CL	45	62619	H-CARK2-2400-CM	45	62688	HV-2000-2SAC-CL-S/S	46
62508	HSA8CLL	55	62554	H-CARK-1800-CS	45	62620	H-CARK2-2400-CL	45	62689	HV-2000-2SAC-CLL-S/S	46
62509	HSA8CS-S/S	46	62555	H-CARK-1800-CM	45	62621	H-CARK2-2400-CLL	45	62690	HV-2200-2SAC-CM-S/S	46
62509	HSA8CS-S/S	48	62556	H-CARK-1800-CL	45	62622	H-CARK2-2600-CM	45	62691	HV-2200-2SAC-CL-S/S	46
62509	HSA8CS-S/S	49	62557	HV-1200-2SAC-CS	44	62623	H-CARK2-2600-CL	45	62692	HV-2200-2SAC-CLL-S/S	46
62509	HSA8CS-S/S	52	62558	HV-1200-2SAC-CM	44	62624	H-CARK2-2600-CLL	45	62693	HV-2400-2SAC-CM-S/S	46
62509	HSA8CS-S/S	54	62559	HV-1200-2SAC-CL	44	62625	H-CARK2-2800-CM	45	62694	HV-2400-2SAC-CL-S/S	46
62509	HSA8CS-S/S	55	62560	HV-1200-2SAC-CLL	44	62626	H-CARK2-2800-CL	45	62695	HV-2400-2SAC-CLL-S/S	46
62510	HSA8CM-S/S	46	62561	HV-1400-2SAC-CS	44	62627	H-CARK2-2800-CLL	45	62696	HV-2600-2SAC-CM-S/S	46
62510	HSA8CM-S/S	48	62562	HV-1400-2SAC-CM	44	62628	H-CARK2-3000-CM	45	62697	HV-2600-2SAC-CL-S/S	46
62510	HSA8CM-S/S	49	62563	HV-1400-2SAC-CL	44	62629	H-CARK2-3000-CL	45	62698	HV-2600-2SAC-CLL-S/S	46
62510	HSA8CM-S/S	52	62564	HV-1400-2SAC-CLL	44	62630	H-CARK2-3000-CLL	45	62699	HV-2800-2SAC-CM-S/S	46
62510	HSA8CM-S/S	54	62565	HV-1600-2SAC-CM	44	62631	HV-600-SAC-CS-S/S	46	62700	HV-2800-2SAC-CL-S/S	46
62510	HSA8CM-S/S	55	62566	HV-1600-2SAC-CL	44	62632	HV-600-SAC-CM-S/S	46	62701	HV-2800-2SAC-CLL-S/S	46
62511	HSA8CL-S/S	46	62567	HV-1600-2SAC-CLL	44	62633	HV-600-SAC-CL-S/S	46	62702	HV-3000-2SAC-CM-S/S	46

INDEX By Item Code

Item Code	Ordering Number	Page #	Item Code	Ordering Number	Page #	Item Code	Ordering Number	Page #	Item Code	Ordering Number	Page #
62703	HV-3000-2SAC-CL-S/S	46	62750	H73CSK-B-S/S	48	62830	HTF236-S/S	15	63226	HV-1800-SAC-CLL-EL15	50
62704	HV-3000-2SAC-CLL-S/S	46	62750	H73CSK-B-S/S	49	62831	HTF242-S/S	15	63227	HV-600-SAC-CS-S/S-EL15	52
62705	H-CARK2-1200-CS-S/S	47	62750	H73CSK-B-S/S	54	62832	HTF248-S/S	15	63228	HV-600-SAC-CM-S/S-EL15	52
62706	H-CARK2-1200-CM-S/S	47	62750	H73CSK-B-S/S	55	62833	HTF254-S/S	15	63229	HV-600-SAC-CL-S/S-EL15	52
62707	H-CARK2-1200-CL-S/S	47	62751	HCP-600	48	62834	HTF260-S/S	15	63230	HV-800-SAC-CS-S/S-EL15	52
62708	H-CARK2-1200-CLL-S/S	47	62751	HCP-600	54	62835	HTF272-S/S	15	63231	HV-800-SAC-CM-S/S-EL15	52
62709	H-CARK2-1400-CS-S/S	47	62752	HCP-800	48	62836	EZP-LS212-S/S	10	63232	HV-800-SAC-CL-S/S-EL15	52
62710	H-CARK2-1400-CM-S/S	47	62752	HCP-800	54	62837	EZP-LS218-S/S	10	63233	HV-1000-SAC-CS-S/S-EL15	52
62711	H-CARK2-1400-CL-S/S	47	62753	HCP-1000	48	62838	EZP-LS224-S/S	10	63234	HV-1000-SAC-CM-S/S-EL15	52
62712	H-CARK2-1400-CLL-S/S	47	62753	HCP-1000	54	62839	EZP-LS230-S/S	10	63235	HV-1000-SAC-CL-S/S-EL15	52
62713	H-CARK2-1600-CM-S/S	47	62754	HCP-1200	48	62840	EZP-LS236-S/S	10	63236	HV-1200-SAC-CS-S/S-EL15	52
62714	H-CARK2-1600-CL-S/S	47	62754	HCP-1200	54	62841	EZP-LS242-S/S	10	63237	HV-1200-SAC-CM-S/S-EL15	52
62715	H-CARK2-1600-CLL-S/S	47	62755	HCP-1400	48	62842	EZP-LS248-S/S	10	63238	HV-1200-SAC-CL-S/S-EL15	52
62716	H-CARK2-1800-CM-S/S	47	62755	HCP-1400	54	62843	EZP-LS254-S/S	10	63239	HV-1400-SAC-CS-S/S-EL15	52
62717	H-CARK2-1800-CL-S/S	47	62756	HCP-1800	48	62844	EZP-LS260-S/S	10	63240	HV-1400-SAC-CM-S/S-EL15	52
62718	H-CARK2-1800-CLL-S/S	47	62756	HCP-1800	54	62845	EZP-LS212HT-S/S	10	63241	HV-1400-SAC-CL-S/S-EL15	52
62719	H-CARK2-2000-CM-S/S	47	62757	HCP-600-S/S	48	62846	EZP-LS218HT-S/S	10	63242	HV-1600-SAC-CM-S/S-EL15	52
62720	H-CARK2-2000-CL-S/S	47	62757	HCP-600-S/S	54	62847	EZP-LS224HT-S/S	10	63243	HV-1600-SAC-CL-S/S-EL15	52
62721	H-CARK2-2000-CLL-S/S	47	62758	HCP-800-S/S	48	62848	EZP-LS230HT-S/S	10	63244	HV-1600-SAC-CLL-S/S-EL15	52
62722	H-CARK2-2200-CM-S/S	47	62758	HCP-800-S/S	54	62849	EZP-LS236HT-S/S	10	63245	HV-1800-SAC-CM-S/S-EL15	52
62723	H-CARK2-2200-CL-S/S	47	62759	HCP-1000-S/S	48	62850	EZP-LS242HT-S/S	10	63246	HV-1800-SAC-CL-S/S-EL15	52
62724	H-CARK2-2200-CLL-S/S	47	62759	HCP-1000-S/S	54	62851	EZP-LS248HT-S/S	10	63247	HV-1800-SAC-CLL-S/S-EL15	52
62725	H-CARK2-2400-CM-S/S	47	62760	HCP-1200-S/S	48	62852	EZP-LS254HT-S/S	10	63421	HV-1200-2SAC-CS-EL15	50
62726	H-CARK2-2400-CL-S/S	47	62760	HCP-1200-S/S	54	62853	EZP-LS260HT-S/S	10	63422	HV-1200-2SAC-CM-EL15	50
62727	H-CARK2-2400-CLL-S/S	47	62761	HCP-1400-S/S	48	63020	MSTHD-G	71	63423	HV-1200-2SAC-CL-EL15	50
62728	H-CARK2-2600-CM-S/S	47	62761	HCP-1400-S/S	54	63020	MSTHD-G	73	63424	HV-1200-2SAC-CLL-EL15	50
62729	H-CARK2-2600-CL-S/S	47	62762	HCP-1800-S/S	48	63020	MSTHD-G	117	63425	HV-1400-2SAC-CS-EL15	50
62730	H-CARK2-2600-CLL-S/S	47	62762	HCP-1800-S/S	54	63024	CBD-ST-XL-S	157	63426	HV-1400-2SAC-CM-EL15	50
62731	H-CARK2-2800-CM-S/S	47	62763	H2CP-1200	49	63067	MSTBBK	71	63427	HV-1400-2SAC-CL-EL15	50
62732	H-CARK2-2800-CL-S/S	47	62763	H2CP-1200	55	63067	MSTBBK	71	63428	HV-1400-2SAC-CLL-EL15	50
62733	H-CARK2-2800-CLL-S/S	47	62764	H2CP-1400	49	63067	MSTBBK	73	63429	HV-1600-2SAC-CM-EL15	50
62734	H-CARK2-3000-CM-S/S	47	62764	H2CP-1400	55	63067	MSTBBK	73	63430	HV-1600-2SAC-CL-EL15	50
62735	H-CARK2-3000-CL-S/S	47	62765	H2CP-1600	49	63067	MSTBBK	117	63431	HV-1600-2SAC-CLL-EL15	50
62736	H-CARK2-3000-CLL-S/S	47	62765	H2CP-1600	55	63067	MSTBBK	117	63432	HV-1800-2SAC-CM-EL15	50
62741	H60CSK-G	43	62766	H2CP-1800	49	63072	ATVK-73	74	63433	HV-1800-2SAC-CL-EL15	50
62741	HCSTK-60-G	42	62766	H2CP-1800	55	63072	ATVK-73	79	63434	HV-1800-2SAC-CLL-EL15	50
62742	H60CSK-G-S/S	43	62767	H2CP-2000	49	63072	ATVK-73	99	63435	HV-2000-2SAC-CM-EL15	50
62742	HCSTK-60-G-S/S	42	62767	H2CP-2000	55	63073	ATV-MOUNT	74	63436	HV-2000-2SAC-CL-EL15	50
62743	H73CSK-G	42	62768	H2CP-2400	49	63073	ATV-MOUNT	79	63437	HV-2000-2SAC-CLL-EL15	50
62743	H73CSK-G	43	62768	H2CP-2400	55	63073	ATV-MOUNT	99	63438	HV-2200-2SAC-CM-EL15	50
62743	H73CSK-G	48	62769	H2CP-2600	49	63079	H73BTK	48	63439	HV-2200-2SAC-CL-EL15	50
62743	H73CSK-G	49	62769	H2CP-2600	55	63079	H73BTK	49	63440	HV-2200-2SAC-CLL-EL15	50
62743	H73CSK-G	54	62770	H2CP-2800	49	63079	H73BTK	54	63441	HV-2400-2SAC-CM-EL15	50
62743	H73CSK-G	55	62770	H2CP-2800	55	63079	H73BTK	55	63442	HV-2400-2SAC-CL-EL15	50
62744	H73CSK-G-S/S	42	62771	H2CP-3000	49	63080	H73BTK-S/S	48	63443	HV-2400-2SAC-CLL-EL15	50
62744	H73CSK-G-S/S	43	62771	H2CP-3000	55	63080	H73BTK-S/S	49	63444	HV-2600-2SAC-CM-EL15	50
62744	H73CSK-G-S/S	48	62801	H2CP-1200-S/S	49	63080	H73BTK-S/S	54	63445	HV-2600-2SAC-CL-EL15	50
62744	H73CSK-G-S/S	49	62801	H2CP-1200-S/S	55	63080	H73BTK-S/S	55	63446	HV-2600-2SAC-CLL-EL15	50
62744	H73CSK-G-S/S	54	62802	H2CP-1400-S/S	49	63206	HV-600-SAC-CS-EL15	50	63447	HV-2800-2SAC-CM-EL15	50
62744	H73CSK-G-S/S	55	62802	H2CP-1400-S/S	55	63207	HV-600-SAC-CM-EL15	50	63448	HV-2800-2SAC-CL-EL15	50
62745	H73CSK-S	43	62803	H2CP-1600-S/S	49	63208	HV-600-SAC-CL-EL15	50	63449	HV-2800-2SAC-CLL-EL15	50
62745	H73CSK-S	49	62803	H2CP-1600-S/S	55	63209	HV-800-SAC-CS-EL15	50	63450	HV-3000-2SAC-CM-EL15	50
62745	H73CSK-S	55	62804	H2CP-1800-S/S	49	63210	HV-800-SAC-CM-EL15	50	63451	HV-3000-2SAC-CL-EL15	50
62746	H73CSK-S-S/S	43	62804	H2CP-1800-S/S	55	63211	HV-800-SAC-CL-EL15	50	63452	HV-3000-2SAC-CLL-EL15	50
62746	H73CSK-S-S/S	49	62805	H2CP-2000-S/S	49	63212	HV-1000-SAC-CS-EL15	50	63453	HV-1200-2SAC-CS-S/S-EL15	52
62746	H73CSK-S-S/S	55	62805	H2CP-2000-S/S	55	63213	HV-1000-SAC-CM-EL15	50	63454	HV-1200-2SAC-CM-S/S-EL15	52
62747	H60CSK-B	43	62806	H2CP-2400-S/S	49	63214	HV-1000-SAC-CL-EL15	50	63455	HV-1200-2SAC-CL-S/S-EL15	52
62747	HCSTK-60-B	42	62806	H2CP-2400-S/S	55	63215	HV-1200-SAC-CS-EL15	50	63456	HV-1200-2SAC-CLL-S/S-EL15	52
62748	H60CSK-B-S/S	43	62807	H2CP-2600-S/S	49	63216	HV-1200-SAC-CM-EL15	50	63457	HV-1400-2SAC-CS-S/S-EL15	52
62748	HCSTK-60-B-S/S	42	62807	H2CP-2600-S/S	55	63217	HV-1200-SAC-CL-EL15	50	63458	HV-1400-2SAC-CM-S/S-EL15	52
62749	H73CSK-B	42	62808	H2CP-2800-S/S	49	63218	HV-1400-SAC-CS-EL15	50	63459	HV-1400-2SAC-CL-S/S-EL15	52
62749	H73CSK-B	43	62808	H2CP-2800-S/S	55	63219	HV-1400-SAC-CM-EL15	50	63460	HV-1400-2SAC-CLL-S/S-EL15	52
62749	H73CSK-B	48	62809	H2CP-3000-S/S	49	63220	HV-1400-SAC-CL-EL15	50	63461	HV-1600-2SAC-CM-S/S-EL15	52
62749	H73CSK-B	49	62809	H2CP-3000-S/S	55	63221	HV-1600-SAC-CM-EL15	50	63462	HV-1600-2SAC-CL-S/S-EL15	52
62749	H73CSK-B	54	62826	HTF212-S/S	15	63222	HV-1600-SAC-CL-EL15	50	63463	HV-1600-2SAC-CLL-S/S-EL15	52
62749	H73CSK-B	55	62827	HTF218-S/S	15	63223	HV-1600-SAC-CLL-EL15	50	63464	HV-1800-2SAC-CM-S/S-EL15	52
62750	H73CSK-B-S/S	42	62828	HTF224-S/S	15	63224	HV-1800-SAC-CM-EL15	50	63465	HV-1800-2SAC-CL-S/S-EL15	52
62750	H73CSK-B-S/S	43	62829	HTF230-S/S	15	63225	HV-1800-SAC-CL-EL15	50	63466	HV-1800-2SAC-CLL-S/S-EL15	52

INDEX By Item Code

Item Code	Ordering Number	Page #	Item Code	Ordering Number	Page #	Item Code	Ordering Number	Page #	Item Code	Ordering Number	Page #
63467	HV-2000-2SAC-CM-S/S-EL15	52	63599	H-CARK2-1200-CS-S/S-EL15	53	63641	H-CARK-1200-CM-EL15	51	63962	HV1600LL-PCST	40
63468	HV-2000-2SAC-CL-S/S-EL15	52	63600	H-CARK2-1200-CM-S/S-EL15	53	63642	H-CARK-1200-CL-EL15	51	63963	HV1800M-PCST	40
63469	HV-2000-2SAC-CLL-S/S-EL15	52	63601	H-CARK2-1200-CL-S/S-EL15	53	63643	H-CARK-1400-CS-EL15	51	63964	HV1800LL-PCST	40
63470	HV-2200-2SAC-CM-S/S-EL15	52	63602	H-CARK2-1200-CLL-S/S-EL15	53	63644	H-CARK-1400-CM-EL15	51	63965	HV1800LL-PCST	40
63471	HV-2200-2SAC-CL-S/S-EL15	52	63603	H-CARK2-1400-CS-S/S-EL15	53	63645	H-CARK-1400-CL-EL15	51	63966	HV2100M-PCST	40
63472	HV-2200-2SAC-CLL-S/S-EL15	52	63604	H-CARK2-1400-CM-S/S-EL15	53	63646	H-CARK-1600-CS-EL15	51	63967	HV2100LL-PCST	40
63473	HV-2400-2SAC-CM-S/S-EL15	52	63605	H-CARK2-1400-CL-S/S-EL15	53	63647	H-CARK-1600-CM-EL15	51	63968	HV2100LL-PCST	40
63474	HV-2400-2SAC-CL-S/S-EL15	52	63606	H-CARK2-1400-CLL-S/S-EL15	53	63648	H-CARK-1600-CL-EL15	51	63969	HV2400M-PCST	40
63475	HV-2400-2SAC-CLL-S/S-EL15	52	63607	H-CARK2-1600-CM-S/S-EL15	53	63649	H-CARK-1800-CS-EL15	51	63970	HV2400LL-PCST	40
63476	HV-2600-2SAC-CM-S/S-EL15	52	63608	H-CARK2-1600-CL-S/S-EL15	53	63650	H-CARK-1800-CM-EL15	51	63971	HV2400LL-PCST	40
63477	HV-2600-2SAC-CL-S/S-EL15	52	63609	H-CARK2-1600-CLL-S/S-EL15	53	63651	H-CARK-1800-CL-EL15	51	63972	HV2600M-PCST	40
63478	HV-2600-2SAC-CLL-S/S-EL15	52	63610	H-CARK2-1800-CM-S/S-EL15	53	63652	H-CARK-600-CS-S/S-EL15	53	63973	HV2600LL-PCST	40
63479	HV-2800-2SAC-CM-S/S-EL15	52	63611	H-CARK2-1800-CL-S/S-EL15	53	63653	H-CARK-600-CM-S/S-EL15	53	63974	HV2600LL-PCST	40
63480	HV-2800-2SAC-CL-S/S-EL15	52	63612	H-CARK2-1800-CLL-S/S-EL15	53	63654	H-CARK-600-CL-S/S-EL15	53	63975	HV3000M-PCST	40
63481	HV-2800-2SAC-CLL-S/S-EL15	52	63613	H-CARK2-2000-CM-S/S-EL15	53	63655	H-CARK-800-CS-S/S-EL15	53	63976	HV3000LL-PCST	40
63482	HV-3000-2SAC-CM-S/S-EL15	52	63614	H-CARK2-2000-CL-S/S-EL15	53	63656	H-CARK-800-CM-S/S-EL15	53	63977	HV3000LL-PCST	40
63483	HV-3000-2SAC-CL-S/S-EL15	52	63615	H-CARK2-2000-CLL-S/S-EL15	53	63657	H-CARK-800-CL-S/S-EL15	53	63978	HV450SS-PCST-S/S	41
63484	HV-3000-2SAC-CLL-S/S-EL15	52	63616	H-CARK2-2200-CM-S/S-EL15	53	63658	H-CARK-1000-CS-S/S-EL15	53	63979	HV450S-PCST-S/S	41
63554	CBD-XXL-S/S	156	63617	H-CARK2-2200-CL-S/S-EL15	53	63659	H-CARK-1000-CM-S/S-EL15	53	63980	HV450M-PCST-S/S	41
63566	HVT8-EL15-S/S	55	63618	H-CARK2-2200-CLL-S/S-EL15	53	63660	H-CARK-1000-CL-S/S-EL15	53	63981	HV600SS-PCST-S/S	41
63567	H-CARK2-1200-CS-EL15	51	63619	H-CARK2-2400-CM-S/S-EL15	53	63661	H-CARK-1200-CS-S/S-EL15	53	63982	HV600S-PCST-S/S	41
63568	H-CARK2-1200-CM-EL15	51	63620	H-CARK2-2400-CL-S/S-EL15	53	63662	H-CARK-1200-CM-S/S-EL15	53	63983	HV600M-PCST-S/S	41
63569	H-CARK2-1200-CL-EL15	51	63621	H-CARK2-2400-CLL-S/S-EL15	53	63663	H-CARK-1200-CL-S/S-EL15	53	63984	HV750SS-PCST-S/S	41
63570	H-CARK2-1200-CLL-EL15	51	63622	H-CARK2-2600-CM-S/S-EL15	53	63664	H-CARK-1400-CS-S/S-EL15	53	63985	HV750S-PCST-S/S	41
63571	H-CARK2-1400-CS-EL15	51	63623	H-CARK2-2600-CL-S/S-EL15	53	63665	H-CARK-1400-CM-S/S-EL15	53	63986	HV750M-PCST-S/S	41
63572	H-CARK2-1400-CM-EL15	51	63624	H-CARK2-2600-CLL-S/S-EL15	53	63666	H-CARK-1400-CL-S/S-EL15	53	63987	HV900SS-PCST-S/S	41
63573	H-CARK2-1400-CL-EL15	51	63625	H-CARK2-2800-CM-S/S-EL15	53	63667	H-CARK-1600-CS-S/S-EL15	53	63988	HV900S-PCST-S/S	41
63574	H-CARK2-1400-CLL-EL15	51	63626	H-CARK2-2800-CL-S/S-EL15	53	63668	H-CARK-1600-CM-S/S-EL15	53	63989	HV900M-PCST-S/S	41
63575	H-CARK2-1600-CM-EL15	51	63627	H-CARK2-2800-CLL-S/S-EL15	53	63669	H-CARK-1600-CL-S/S-EL15	53	63990	HV900L-PCST-S/S	41
63576	H-CARK2-1600-CL-EL15	51	63628	H-CARK2-3000-CM-S/S-EL15	53	63670	H-CARK-1800-CS-S/S-EL15	53	63991	HV1050SS-PCST-S/S	41
63577	H-CARK2-1600-CLL-EL15	51	63629	H-CARK2-3000-CL-S/S-EL15	53	63671	H-CARK-1800-CM-S/S-EL15	53	63992	HV1050S-PCST-S/S	41
63578	H-CARK2-1800-CM-EL15	51	63630	H-CARK2-3000-CLL-S/S-EL15	53	63672	H-CARK-1800-CL-S/S-EL15	53	63993	HV1050M-PCST-S/S	41
63579	H-CARK2-1800-CL-EL15	51	63631	H-CARK-600-CS-EL15	51	63678	HDRP22	133	63994	HV1050L-PCST-S/S	41
63580	H-CARK2-1800-CLL-EL15	51	63632	H-CARK-600-CM-EL15	51	63679	HDRP17	133	63995	HV1200SS-PCST-S/S	41
63581	H-CARK2-2000-CM-EL15	51	63633	H-CARK-600-CL-EL15	51	63747	CBD-ST-XXL	157	63996	HV1200S-PCST-S/S	41
63582	H-CARK2-2000-CL-EL15	51	63634	H-CARK-800-CS-EL15	51	63748	CBD-ST-XXL-S/S	157	63997	HV1200M-PCST-S/S	41
63583	H-CARK2-2000-CLL-EL15	51	63635	H-CARK-800-CM-EL15	51	63749	CBD-ST-XXL-MF	157	63998	HV1200L-PCST-S/S	41
63584	H-CARK2-2200-CM-EL15	51	63636	H-CARK-800-CL-EL15	51	63750	CBD-ST-XXL-MF-S/S	157	63999	HV1500M-PCST-S/S	41
63585	H-CARK2-2200-CL-EL15	51	63637	H-CARK-1000-CS-EL15	51	63751	CBD-ST-XXL-FP	157	64000	HV1500L-PCST-S/S	41
63586	H-CARK2-2200-CLL-EL15	51	63638	H-CARK-1000-CM-EL15	51	63752	CBD-ST-XXL-FR-B	157	64001	HV1500LL-PCST-S/S	41
63587	H-CARK2-2400-CM-EL15	51	63639	H-CARK-1000-CL-EL15	51	63791	CBD-ST-XXL-S	157	64002	HV1600M-PCST-S/S	41
63588	H-CARK2-2400-CL-EL15	51	63640	H-CARK-1200-CS-EL15	51	63861	HATDMK-S/S	43	64003	HV1600L-PCST-S/S	41
63589	H-CARK2-2400-CLL-EL15	51				63862	HDATDMK-S/S	43	64004	HV1600LL-PCST-S/S	41
63590	H-CARK2-2600-CM-EL15	51				63936	HV450SS-PCST	40	64005	HVHD1800M-PCST-S/S	41
63591	H-CARK2-2600-CL-EL15	51				63937	HV450S-PCST	40	64006	HVHD1800L-PCST-S/S	41
63592	H-CARK2-2600-CLL-EL15	51				63938	HV450M-PCST	40	64007	HVHD1800LL-PCST-S/S	41
63593	H-CARK2-2800-CM-EL15	51				63939	HV600SS-PCST	40	64008	HVHD2100M-PCST-S/S	41
63594	H-CARK2-2800-CL-EL15	51				63940	HV600S-PCST	40	64009	HVHD2100L-PCST-S/S	41
63595	H-CARK2-2800-CLL-EL15	51				63941	HV600M-PCST	40	64010	HVHD2100LL-PCST-S/S	41
63596	H-CARK2-3000-CM-EL15	51				63942	HV750SS-PCST	40	64011	HVHD2400M-PCST-S/S	41
63597	H-CARK2-3000-CL-EL15	51				63943	HV750S-PCST	40	64012	HVHD2400L-PCST-S/S	41
63598	H-CARK2-3000-CLL-EL15	51				63944	HV750M-PCST	40	64013	HVHD2400LL-PCST-S/S	41
						63945	HV900SS-PCST	40	64014	HVHD2600M-PCST-S/S	41
						63946	HV900S-PCST	40	64015	HVHD2600L-PCST-S/S	41
						63947	HV900M-PCST	40	64016	HVHD2600LL-PCST-S/S	41
						63948	HV900L-PCST	40	64017	HVHD3000M-PCST-S/S	41
						63950	HV1050S-PCST	40	64018	HVHD3000L-PCST-S/S	41
						63951	HV1050M-PCST	40	64019	HVHD3000LL-PCST-S/S	41
						63952	HV1050L-PCST	40	64020	MHS-600-MST	72
						63953	HV1200SS-PCST	40	64021	MHS-750-MST	72
						63954	HV1200S-PCST	40	64022	MHS-900-MST	72
						63955	HV1200M-PCST	40	64023	MHS-1050-MST	72
						63956	HV1200L-PCST	40	64024	MHS-1200-MST	72
						63957	HV1500M-PCST	40	64025	MHS-1350-MST	72
						63958	HV1500L-PCST	40	64026	MHS-1500-MST	72
						63959	HV1500LL-PCST	40	64027	MHS-1800-MST	72
						63960	HV1600M-PCST	40	64028	MHS-2100-MST	72
						63961	HV1600L-PCST	40	64029	MHS-2400-MST	72

INDEX By Item Code

Item Code	Ordering Number	Page #	Item Code	Ordering Number	Page #	Item Code	Ordering Number	Page #	Item Code	Ordering Number	Page #
64030	MHS-600-MST-S/S	72	65664	FMS-1200-EL15	69	67312	YTCHD1500-MST-S/S SECONDARY	58	67563	MDWS-MST-1200	116
64031	MHS-750-MST-S/S	72	65665	FMS-1350-EL15	69				67564	MDWS-MST-1350	116
64032	MHS-900-MST-S/S	72	65666	FMS-1500-EL15	69	67313	YTCHD1800-MST-S/S SECONDARY	58	67565	MDWS-MST-1500	116
64033	MHS-1050-MST-S/S	72	65667	FMS-1800-EL15	69				67566	MDWS-MST-1800	116
64034	MHS-1200-MST-S/S	72	65670	FMS-600-EL15-S/S	69	67314	YTFHD900-MST-S/S SECONDARY	58	67567	MDWS-MST-2100	116
64035	MHS-1350-MST-S/S	72	65671	FMS-750-EL15-S/S	69				67568	MDWS-MST-2400	116
64036	MHS-1500-MST-S/S	72	65672	FMS-900-EL15-S/S	69	67315	YTFHD1050-MST-S/S SECONDARY	58	67750	YCART-S/S-30/750-SDTC	64
64037	MHS-1800-MST-S/S	72	65673	FMS-1050-EL15-S/S	69	67316	YTFHD1200-MST-S/S SECONDARY	58	67751	YCART-S/S-36/900-SDTC	64
64038	MHS-2100-MST-S/S	72	65674	FMS-1200-EL15-S/S	69				67752	YCART-S/S-42/1050-SDTC	64
64039	MHS-2400-MST-S/S	72	65675	FMS-1350-EL15-S/S	69	67317	YTFHD1350-MST-S/S SECONDARY	58	67753	YCART-S/S-48/1200-SDTC	64
64045	HV1050SS-PCST	40	65676	FMS-1500-EL15-S/S	69				71053	FLSC2000	170
64175	AIR HARK-S/S-73	43	65677	FMS-1800-EL15-S/S	69	67318	YTFHD1500-MST-S/S SECONDARY	58	71056	FLSC-TP	170
64178	CBD-S-S/S	156	65746	PTK	73				71057	FLSC-CP	170
64198	YPHD900-S/S POLE	64	65746	PTK	73	67319	YTFHD1800-MST-S/S SECONDARY	58	71059	FLSC2000-MC	170
64199	YPHD1050-S/S POLE	64	65746	PTK	76				71061	FLSC2000-CB	170
64200	YPHD1200-S/S POLE	64	65746	PTK	76	67322	YPHD600-S/S POLE	64	71140	FLSCM-CP	170
64201	YPHD1350-S/S POLE	64	65746	PTK	78	67323	YPHD750-S/S POLE	64	71148	FLSCM2000	170
64202	YPHD1500-S/S POLE	64	65746	PTK	78				72483	CBR-S	156
64204	YPHD1800-S/S POLE	64	66106	FMS-600V-S/S	69	67325		64	72484	CBR-M	156
64205		64	66107	FMS-750V-S/S	69	67327	UFB18-B	114	72485	CBR-L	156
64205		64	66108	FMS-900V-S/S	69	67328	UFB24-B	114	72486	CBR-XL	156
64206		64	66109	FMS-1050V-S/S	69	67329	UFB30-B	114	73003	PP450	66
64206		64	66110	FMS-1200V-S/S	69	67330	UFB36-B	114	73004	PV600	65
64207		64	66111	FMS-1350V-S/S	69	67331	UFB42-B	114	73005	PP600	66
64207		64	66112	FMS-1500V-S/S	69	67332	UFB48-B	114	73006	PV750	65
64208		64	66113	FMS-1800V-S/S	69	67333	UFB54-B	114	73007	PP750	66
64209		64	66255	MHS-1950BTV-2SAC-S/S	103	67334	UFB60-B	114	73008	PV900	65
64211		64	66749	YCART-S/S-24/600-SDTC	64	67335	UFB72-B	114	73009	PP900	66
64310	CBD-ST-BB	157	66956	EZP1-UHT2-450-S/S	15	67336	UFB84-B	114	73010	PV1050	65
64482	CBD-ST-XL-B	157	66957	EZP1-UHT2-600-S/S	15	67409	DWP72-S/S	117	73011	PP1050	66
64620	CBD-ST-B	157	66958	EZP1-UHT2-750-S/S	15	67411	YCART-S/S-36/900-HDTC	64	73012	PV1200	65
64621	CBD-ST-L-B	157	66959	EZP1-UHT2-900-S/S	15	67412	YCART-S/S-42/1050-HDTC	64	73013	PP1200	66
64622	CBD-ST-XXL-B	157	66960	EZP1-UHT2-1050-S/S	15	67413	YCART-S/S-48/1200-HDTC	64	73014	PS600	129
64623	CBD-ST-M-P-S/S	157	66961	EZP1-UHT2-1200-S/S	15	67414	YCART-S/S-54/1350-HDTC	64	73015	PP1400	66
64624	CBD-ST-L-P-S/S	157	66962	EZP1-UHT2-1350-S/S	15	67415	YCART-S/S-60/1500-HDTC	64	73016	PP1500	66
64625	CBD-ST-XL-P-S/S	157	66963	EZP1-UHT2-1500-S/S	15	67416	YCART-S/S-72/1800-HDTC	64	73019	HV450M	38
64626	CBD-ST-XXL-P-S/S	157	66964	EZP1-UHT2-1800-S/S	15	67417	YCART-S/S-36/900-HDP	64	73024	PPS6	66
64772	CBD-ST-M-P	157	66993	EST-P-S/S-UHT	18	67418	YCART-S/S-42/1050-HDP	64	78919	CCMK	62
64773	CBD-ST-L-P	157	66994	EST-W-S/S-UHT	18	67419	YCART-S/S-48/1200-HDP	64	73026	HV450SS	38
64774	CBD-ST-XL-P	157	66995	EST-G-S/S-UHT	18	67420	YCART-S/S-54/1350-HDP	64	73027	HP450	42
64775	CBD-ST-XXL-P	157	67285	YTC600-BT-S/S SECONDARY	58	67421	YCART-S/S-60/1500-HDP	64	73028	HV450S	38
64776	CBD-ST-M-PSS	157	67286	YTC750-BT-S/S SECONDARY	58	67422	YCART-S/S-72/1800-HDP	64	73029	HP600	42
64777	CBD-ST-L-PS	157	67287	YTC900-BT-S/S SECONDARY	58	67466	MDWS-600-S/S	116	73030	HV600S	38
64778	CBD-ST-XL-PS	157	67288	YTC1050-BT-S/S SECONDARY	58	67467	MDWS-750-S/S	116	73031	HP750	42
64779	CBD-ST-XXL-PS	157	67289	YTC1200-BT-S/S SECONDARY	58	67468	MDWS-900-S/S	116	73032	HV750S	38
64780	CBD-ST-M-PS-S/S	157	67290	YTCHD900-BT-S/S SECONDARY	58	67469	MDWS-1050-S/S	116	73033	HP900	42
64781	CBD-ST-L-PS-S/S	157	67291	YTCHD1050-BT-S/S SECONDARY	58	67470	MDWS-1200-S/S	116	73034	HV900S	38
64782	CBD-ST-XL-PS-S/S	157	67292	YTCHD1200-BT-S/S SECONDARY	58	67471	MDWS-1350-S/S	116	73035	HP1050	42
64783	CBD-ST-XXL-PS-S/S	157	67293	YTCHD1350-BT-S/S SECONDARY	58	67472	MDWS-1500-S/S	116	73036	HV1050M	38
64784	CBD-ST-M-S	157	67294	YTCHD1500-BT-S/S SECONDARY	58	67473	MDWS-1800-S/S	116	73037	HP1200	42
64785	CBD-ST-L-S	156	67295	YTCHD1800-BT-S/S SECONDARY	58	67474	MDWS-2100-S/S	116	73038	HV1200M	38
64787	CBD-XXL	156	67308	YTCHD900-MST-S/S SECONDARY	58	67475	MDWS-2400-S/S	116	73045	HV600SS	38
64924	MSR-S/S	169	67309	YTCHD1050-MST-S/S SECONDARY	58	67476	MDWS-MST-600-S/S	116	73047	HSA8SS	38
64925	PMSMK-S/S	169	67310	YTCHD1200-MST-S/S SECONDARY	58	67477	MDWS-MST-750-S/S	116	73047	HSA8SS	40
64926	MAK-S/S	169	67311	YTCHD1350-MST-S/S SECONDARY	58	67478	MDWS-MST-900-S/S	116	73048	HSA8S	38
64930	MSTLP	71				67479	MDWS-MST-1050-S/S	116	73048	HSA8S	40
64930	MSTLP	73				67480	MDWS-MST-1200-S/S	116	73049	HSA8M	38
64930	MSTLP	73				67481	MDWS-MST-1350-S/S	116	73049	HSA8M	40
64930	MSTLP	117				67482	MDWS-MST-1500-S/S	116	73050	HPS8	42
64930	MSTLP	117				67483	MDWS-MST-1800-S/S	116	73053	HV750SS	38
64931	MSTAM-S/S	71				67484	MDWS-MST-2100-S/S	116	73054	HMK	42
64931	MSTAM-S/S	73				67485	MDWS-MST-2400-S/S	116	73055	HV900SS	38
64931	MSTAM-S/S	117				67486	DWP84-S/S	117	73056	HV1050S	38
65660	FMS-600-EL15	69				67487	DWP96-S/S	117	73057	HV1050SS	38
65661	FMS-750-EL15	69				67559	MDWS-MST-600	116	73058	HV1200S	38
65662	FMS-900-EL15	69				67560	MDWS-MST-750	116	73059	HV1200SS	38
65663	FMS-1050-EL15	69				67561	MDWS-MST-900	116	73063	HSA8L	38
						67562	MDWS-MST-1050	116	73063	HSA8L	40

INDEX By Item Code

Item Code	Ordering Number	Page #	Item Code	Ordering Number	Page #	Item Code	Ordering Number	Page #	Item Code	Ordering Number	Page #
73064	HSA8LL	38	73443	HXF1600M	36	73772	HSA8S-S/S	39	74535	CT6	98
73064	HSA8LL	40	73444	HXF1600L	36	73772	HSA8S-S/S	41	74535	CT6	101
73066	HP1500	42	73483	HSJD	42	73773	HSA8M-S/S	39	74535	CT6 (C-Tip)	82
73068	HBRK	42	73483	HSJD	48	73773	HSA8M-S/S	41	74535	CT6 (C-Tip)	89
73069	HARK	42	73483	HSJD	49	73774	HSA8L-S/S	39	74535	CT6 (C-Tip)	96
73069	HARK	112	73483	HSJD	54	73774	HSA8L-S/S	41	74539	HVHD2100M	38
73102	BP450	150	73483	HSJD	55	73777	BP600-B	151	74540	HVHD2100L	38
73104	BP600	150	73486	HSA	42	73778	BP750-B	151	74541	HVHD2100LL	38
73106	BP750	150	73489	HSA200	38	73779	BP900-B	151	74544	HVHD2400M	38
73107	BP800	150	73489	HSA200	40	73780	BP1050-B	151	74545	HVHD2400L	38
73108	BP900	150	73489	HSA200	42	73781	BP1200-B	151	74546	HVHD2400LL	38
73109	BP450-750-PL	151	73489	HSA200	44	73782	BP1400-B	151	74547	HPHD2000	42
73110	BP1050	150	73489	HSA200	44	73783	BP1500-B	151	74548	HPHD2400	42
73111	BP800-1050-PL	151	73489	HSA200	44	73784	BP1600-B	151	74549	HBRKX	42
73112	BP1200	150	73489	HSA200	44	73785	BP1800-B	151	74550	HDARK	42
73113	BP1400	150	73489	HSA200	44	73922	HBP-MB-TP	153	74551	HDMK	42
73114	BP1500	150	73489	HSA200	48	73922	HBP-MB-TP	155	74553	PVHD2100	65
73115	BP1600	150	73489	HSA200	49	73946	RBPFK-S	159	74555	PVHD2400	65
73117	BP1800	150	73489	HSA200	50	73947	RBPFK-M	159	74556	PPHD2000	66
73118	BP1200-1400-PL	151	73489	HSA200	54	73948	RBPFK-L	159	74557	PPHD2400	66
73119	BP1500-1600-PL	151	73489	HSA200	55	73949	RBPFK-XL	159	74558	PSR-S	158
73121	BP1800-PL	151	73494	HVC-S/S	42	74033	HSA8LL-S/S	39	74559	PSR-M	158
73123	BP-MB	151	73537	PS1800	129	74033	HSA8LL-S/S	41	74560	PSR-L	158
73125	BP-SC	151	73539	PS2000	129	74049	PS1800PL	129	74561	PSR-XL	158
73127	BP-LA	151	73541	PS750	129	74050	PS2000 PL	129	74562	RBPSR-S	159
73138	BP-TB	151	73542	PS900	129	74053	PSN11010	129	74563	RBPSR-M	159
73139	BP-UB	151	73543	PS1050	129	74055	BP450-B	151	74564	RBPSR-L	159
73141	BP-TL	151	73544	PS1200	129	74057	BP800-B	151	74565	RBPSR-XL	159
73147	BP1500-1600MF	151	73545	PS1500	129	74100	HW-BC	133	74582	HDMRK	42
73148	BP1800MF	151	73546	PS1400	129	74141	HTTS	133	74582	HDMRK	42
73152	BP450-750MF	151	73582	PS600PL	129	74307	HXF8SS	36	74591	HVHD3000M	38
73153	BP800-1050MF	151	73583	PS750PL	129	74307	HXF8SS	37	74592	HVHD3000L	38
73154	BP1200-1400MF	151	73584	PS900PL	129	74327	RBPMBK	159	74593	HVHD3000LL	38
73156	PSA150	66	73585	PS1050PL	129	74417	STJK	42	74597	PPHD1800	66
73156	PSA150	85	73586	PS1200PL	129	74417	STJK	42	74598	PVHD1800	65
73156	PSA150 (V-Tip)	82	73587	PS1400PL	129	74417	STJK-S/S	112	74601	HPHD1800	42
73158	HV1500L	38	73588	PS1500PL	129	74417	STJK-S/S	113	74602	HVHD1800M	38
73162	RBPCP	159	73626	PHA	66	74419	STTS	42	74604	RP450	68
73163	RBPRET	165	73626	PHA	85	74419	STTS	112	74605	RP600	68
73173	HV600M	38	73628	RSA150	68	74420	UTS	42	74606	RP750	68
73174	HV750M	38	73628	RSA150	69	74448	UFB18	114	74607	RP900	68
73175	HV900M	38	73628	RSA150	71	74449	UFB24	114	74608	RP1050	68
73177	HV1500M	38	73628	RSA150	73	74450	UFB30	114	74609	RP1200	68
73178	HV900L	38	73628	RSA150	76	74451	UFB36	114	74610	RP1400	68
73179	HV1050L	38	73628	RSA150	78	74452	UFB42	114	74611	RP1500	68
73180	HV1200L	38	73628	RSA150	92	74453	UFB48	114	74613	RPHD1800	68
73215	HV1500LL	38	73628	RSA150	98	74454	UFB54	114	74614	RPHD2000	68
73221	PSSS-N	129	73628	RSA150	105	74455	UFB60	114	74615	RPHD2400	68
73222	PSSS-H	129	73628	RSA150 (V-Tip)	89	74456	UFB72	114	74633	RV450	67
73235	CCKHDT S-S/S	66	73628	RSA150 (V-Tip)	96	74460	UFB84	114	74634	RV600	67
73235	CCKHDT S-S/S	68	73628	RSA150 (V-Tip)	103	74477	HVHD1800L	38	74635	RV750	67
73235	CCKHDT S-S/S	76	73631	HVPT-S/S	38	74478	HVHD1800LL	38	74636	RV900	67
73301	HBP1200-B	151	73631	HVPT-S/S	39	74490	HBP-SC-TP	153	74637	RV1050	67
73302	HBP1400-B	151	73631	HVPT-S/S	40	74490	HDCK	42	74638	RV1200	67
73303	HBP1500-B	151	73631	HVPT-S/S	41	74502	HDTS	112	74639	RV1400	67
73304	HBP1600-B	151	73631	HVPT-S/S	42	74504	STKD	42	74640	RV1500	67
73306	HBP1800-B	151	73631	HVPT-S/S	46	74506	STCK	42	74642	RVHD1800	67
73307	HBP2000-B	151	73631	HVPT-S/S	48	74535	CT6	66	74643	RVHD2100	67
73308	HBP2200-B	151	73631	HVPT-S/S	49	74535	CT6	68	74644	RVHD2400	67
73309	HBP2400-B	151	73631	HVPT-S/S	52	74535	CT6	69	74659	HXF450S	36
73311	HBP2500-B	151	73631	HVPT-S/S	54	74535	CT6	71	74660	HXF450M	36
73433	PHSC-S/S	66	73631	HVPT-S/S	55	74535	CT6	73	74661	HXF600S	36
73433	PHSC-S/S	87	73637	HV1600M	38	74535	CT6	76	74662	HXF600M	36
73433	PHSC-S/S	129	73638	HV1600L	38	74535	CT6	78	74663	HXF750S	36
73434	PSVA	129	73639	HV1600LL	38	74535	CT6	85	74664	HXF750M	36
73435	PV450	65	73739	HP1600	42	74535	CT6	87	74665	HXF900S	36
73436	PV1400	65	73771	HSA8SS-S/S	39	74535	CT6	92	74666	HXF900M	36
73437	PV1500	65	73771	HSA8SS-S/S	41	74535	CT6	94	74667	HXF900L	36

INDEX By Item Code

Item Code	Ordering Number	Page #	Item Code	Ordering Number	Page #	Item Code	Ordering Number	Page #	Item Code	Ordering Number	Page #
74668	HXF1050S	36	75297	HV600S-S/S	39	75419	HVT8-S/S	49	75521	PMBR-S/S	94
74669	HXF1050M	36	75298	HV600M-S/S	39	75419	HVT8-S/S	52	75521	PMBR-S/S	99
74670	HXF1050L	36	75299	HV750SS-S/S	39	75419	HVT8-S/S	54	75521	PMBR-S/S	107
74671	HXF1200S	36	75300	HV750S-S/S	39	75419	HVT8-S/S	55	75531	MFASK	169
74672	HXF1200M	36	75301	HV750M-S/S	39	75420	PVT6-S/S	66	75531	MFASK	169
74673	HXF1200L	36	75302	HV900SS-S/S	39	75420	PVT6-S/S	87	75565	HSA8SSS	39
74677	HXF1500M	36	75303	HV900S-S/S	39	75420	PVT6-S/S	129	75565	HSA8SSS	40
74678	HXF1500L	36	75304	HV900M-S/S	39	75422	HBRK-S/S	42	75585	STTS-S/S	113
74681	HXFHD1800M	36	75305	HV900L-S/S	39	75422	HBRK-S/S-60	43	75586	HDT8-S/S	113
74682	HXFHD1800L	36	75306	HV1050SS-S/S	39	75423	HARK-S/S	42	75611	EZP1-218	15
74683	HXFHD2100M	36	75307	HV1050S-S/S	39	75424	HMK-S/S	42	75612	EZP1-224	15
74684	HXFHD2100L	36	75308	HV1050M-S/S	39	75425	STCK-S/S	42	75613	EZP1-230	15
74685	HXFHD2400M	36	75309	HV1050L-S/S	39	75426	STJ-S/S	113	75614	EZP1-236	15
74686	HXFHD2400L	36	75310	HV1200SS-S/S	39	75426	STJM-S/S	42	75615	EZP1-242	15
74689	HXF8S	36	75311	HV1200S-S/S	39	75426	STJM-S/S	42	75616	EZP1-248	15
74689	HXF8S	37	75312	HV1200M-S/S	39	75427	STKD-S/S	42	75617	EZP1-254	15
74690	HXF8M	36	75313	HV1200L-S/S	39	75452	PVHD2000	65	75618	EZP1-260	15
74690	HXF8M	37	75314	HV1500M-S/S	39	75463	RVHD2000	67	75619	EZP1P12	17
74691	HXF8L	36	75315	HV1500L-S/S	39	75507	PCB	62	75619	EZP1P12	21
74691	HXF8L	37	75316	HV1500LL-S/S	39	75510	PHDCB	63	75620	EZP1P18	17
74773	PSSS	66	75317	HV1600M-S/S	39	75513	PAB	62	75620	EZP1P18	21
74775	STJM	42	75318	HV1600L-S/S	39	75513	PAB	63	75621	EZP1P24	17
74775	STJM	42	75319	HV1600LL-S/S	39	75513	PAB	66	75621	EZP1P24	21
74775	STJM	112	75323	PV450-S/S	65	75513	PAB	68	75622	EZP1P30	17
74914	MSR	167	75324	PV600-S/S	65	75513	PAB	76	75622	EZP1P30	21
74914	MSR	169	75325	PV750-S/S	65	75513	PAB	85	75623	EZP1P36	17
74916	PMSMK	169	75326	PV900-S/S	65	75513	PAB	92	75623	EZP1P36	21
74918	MAK	169	75327	PV1050-S/S	65	75513	PAB	105	75624	EZP1P42	17
74919	MAKHD	169	75328	PV1200-S/S	65	75513	PAB	123	75624	EZP1P42	21
74919	MAKHD	169	75329	PV1400-S/S	65	75515	PAB-S/S	66	75625	EZP1P48	17
74921	MORK	169	75330	PV1500-S/S	65	75515	PAB-S/S	68	75625	EZP1P48	21
74921	MORK	169	75341	RV450-S/S	67	75515	PAB-S/S	76	75626	EZP1P54	17
74923	MCRK	169	75342	RV600-S/S	67	75515	PAB-S/S	87	75626	EZP1P54	21
74923	MCRK	169	75343	RV750-S/S	67	75515	PAB-S/S	94	75627	EZP1P60	17
74925	MCB	169	75344	RV900-S/S	67	75515	PAB-S/S	107	75627	EZP1P60	21
74925	MCB	169	75345	RV1050-S/S	67	75516	PMBL	85	75629	CRB16	19
74927	MCSK	169	75346	RV1200-S/S	67	75516	PMBL	92	75630	CRB22	19
74927	MCSK	169	75347	RV1400-S/S	67	75516	PMBL	105	75631	CRB28	19
74928	MCSKHD	169	75348	RV1500-S/S	67	75516	PMBL	123	75632	CRB34	19
74928	MCSKHD	169	75373	HP450-S/S	42	75516	PMBL (left)	62	75633	CRB40	19
74930	MCS	169	75374	HP600-S/S	42	75516	PMBL (left)	63	75634	CRB46	19
74930	MCS	169	75375	HP750-S/S	42	75516	PMBL (left)	66	75635	CRB52	19
74931	MCSHD	169	75376	HP900-S/S	42	75516	PMBL (left)	68	75636	CRB58	19
74931	MCSHD	169	75377	HP1050-S/S	42	75516	PMBL (left)	76	75637	EZP1MPK	17
74941	SRBK	133	75378	HP1200-S/S	42	75518	PMBL-S/S	74	75641	EZP1P72	17
75266	HXF450S-S/S	37	75379	HP1500-S/S	42	75518	PMBL-S/S	79	75641	EZP1PL	21
75267	HXF450M-S/S	37	75380	HP1600-S/S	42	75518	PMBL-S/S	87	75642	EZP1BP	17
75268	HXF600S-S/S	37	75382	PP450-S/S	66	75518	PMBL-S/S	94	75642	EZP1BP	21
75269	HXF600M-S/S	37	75383	PP600-S/S	66	75518	PMBL-S/S	99	75771	EZP1-272	15
75270	HXF750S-S/S	37	75384	PP750-S/S	66	75518	PMBL-S/S	107	75772	EZP1P72	17
75271	HXF750M-S/S	37	75385	PP900-S/S	66	75518	PMBL-S/S (left)	66	75772	EZP1P72	21
75272	HXF900S-S/S	37	75386	PP1050-S/S	66	75518	PMBL-S/S (left)	68	75773	CRB70	19
75273	HXF900M-S/S	37	75387	PP1200-S/S	66	75518	PMBL-S/S (left)	76	75775	CRB64	19
75274	HXF900L-S/S	37	75388	PP1400-S/S	66	75519	PMBL (right)	66	75804	MSPP30	117
75275	HXF1050S-S/S	37	75389	PP1500-S/S	66	75519	PMBL (right)	68	75805	MSPP36	117
75276	HXF1050M-S/S	37	75400	RP450-S/S	68	75519	PMBL (right)	76	75806	MSPP42	117
75277	HXF1050L-S/S	37	75401	RP600-S/S	68	75519	PMBR	85	75807	MSPP48	117
75278	HXF1200S-S/S	37	75402	RP750-S/S	68	75519	PMBR	92	75808	MSPP54	117
75279	HXF1200M-S/S	37	75403	RP900-S/S	68	75519	PMBR	105	75809	MSPP60	117
75280	HXF1200L-S/S	37	75404	RP1050-S/S	68	75519	PMBR	123	75811	MSPMPK	25
75281	HXF1500M-S/S	37	75405	RP1200-S/S	68	75519	PMBR (right)	62	75817	RMC1-CB	171
75282	HXF1500L-S/S	37	75406	RP1400-S/S	68	75519	PMBR (right)	63	75832	RMC1-PP	171
75283	HXF1600M-S/S	37	75407	RP1500-S/S	68	75521	PMBL-S/S (right)	66	75843	STS-S	63
75284	HXF1600L-S/S	37	75419	HVT8-S/S	39	75521	PMBL-S/S (right)	68	75843	STS-S	71
75293	HV450SS-S/S	39	75419	HVT8-S/S	41	75521	PMBL-S/S (right)	76	75843	STS-S	73
75294	HV450S-S/S	39	75419	HVT8-S/S	42	75521	PMBR-S/S	74	75843	STS-S	78
75295	HV450M-S/S	39	75419	HVT8-S/S	46	75521	PMBR-S/S	79	75843	STS-S	99
75296	HV600SS-S/S	39	75419	HVT8-S/S	48	75521	PMBR-S/S	87	75843	STS-S	117

INDEX By Item Code

Item Code	Ordering Number	Page #	Item Code	Ordering Number	Page #	Item Code	Ordering Number	Page #	Item Code	Ordering Number	Page #
75843	STS-S	117	75908	AWTCB	26	76205	RVT6-S/S	107	76456	MMP-660	23
75843	STS-S	118	75908	AWTCB	32	76245	HDMRK-S/S	42	76457	MMP-672	23
75844	STS-B	43	75909	AWTHK	26	76245	HDMRK-S/S	42	76458	MMPCP24	25
75844	STS-B	43	75909	AWTHK	32	76246	HBKR-S/S -73	43	76459	MMPCP30	25
75844	STS-B	63	75929	MHCP-24S	30	76246	HBRKX-S/S	42	76460	MMPCP36	25
75844	STS-B	71	75930	MHCP-30S	30	76247	HDARK-S/S	42	76461	MMPCP42	25
75844	STS-B	73	75931	MHCP-36S	30	76248	HDMK-S/S	42	76462	MMPCP48	25
75844	STS-B	78	75932	MHCP-42S	30	76249	RSA	68	76463	MMPCP54	25
75844	STS-B	99	75933	MHCP-48S	30	76249	RSA	92	76464	MMPCP60	25
75844	STS-B	117	75934	MHCP-54S	30	76250	RC-S/S	68	76465	MMPCP72	25
75844	STS-B	117	75935	MHCP-60S	30	76250	RC-S/S	94	76466	MMPBPK	25
75845	QMTS-P	17	75936	MHCP-72S	30	76318	CBD-XL-S/S	156	76467	HSKD-S/S	42
75845	QMTS-P	25	75937	MHCP-24A	30	76319	URCB88/2200	114	76467	HSKD-S/S	48
75845	QMTS-P	112	75938	MHCP-30A	30	76337	BP450-S/S	150	76467	HSKD-S/S	49
75846	STS-W	71	75939	MHCP-36A	30	76338	BP600-S/S	150	76467	HSKD-S/S	54
75846	STS-W	73	75940	MHCP-42A	30	76339	BP750-S/S	150	76467	HSKD-S/S	55
75846	STS-W	78	75941	MHCP-48A	30	76340	BP800-S/S	150	76472	FLEL-M	176
75846	STS-W	99	75942	MHCP-54A	30	76341	BP900-S/S	150	76473	FLEL-L	176
75846	STS-W	117	75943	MHCP-60A	30	76342	BP1050-S/S	150	76474	FLELP	176
75846	STS-W	117	75944	MHCP-72A	30	76343	BP1200-S/S	150	76476	FLTW-M	176
75847	STAK	78	75961	MHP-CP600	32	76344	BP1400-S/S	150	76477	FLTW-L	176
75847	STAK	78	75962	MHP-CP750	32	76345	BP1500-S/S	150	76478	FLRP	176
75847	STAK	99	75963	MHP-CP900	32	76346	BP1600-S/S	150	76479	FLCP	176
75847	STAK	101	75964	MHP-CP1050	32	76347	BP1800-S/S	150	76481	FLRLB-M	176
75847	STAK	117	75965	MHP-CP1200	32	76375	AWT-1S	26	76482	FLRLB-L	176
75847	STAK	117	75966	MHP-CP1400	32	76375	AWT-1S	32	76483	QMT-G	25
75868	MDWS-24	116	75967	MHP-CP1500	32	76392	MHP-EP	25	76484	QMT-G	112
75869	MDWS-30	116	75968	MHP-CP1800	32	76392	MHP-EP	32	76484	QMTS-G	25
75870	MDWS-36	116	75978	SSRB	32	76392	MHP-EP	49	76485	TRB18	23
75871	MDWS-42	116	75978	SSRB	35	76392	MHP-EP	55	76485	TRB18	25
75872	MDWS-48	116	75979	HXF2-SS	36	76392	MHP-EP	84	76485	TRB18	27
75873	MDWS-54	116	75979	HXF2-SS	37	76392	MHP-EP	91	76486	TRB24	23
75874	MDWS-60	116	75980	HXF2-S	36	76392	MHP-EP	98	76486	TRB24	25
75875	MDWS-72	116	75980	HXF2-S	37	76392	MHP-EP	105	76486	TRB24	27
75883	DWP72	117	75981	HXF2-M	36	76393	MHCP-CH	32	76487	TRB30	23
75884	CDWB24	118	75981	HXF2-M	37	76394	MHCP-BS	32	76487	TRB30	25
75885	CDWB30	118	75982	HXF2-L	36	76403	EST-P	17	76487	TRB30	27
75886	CDWB36	118	75982	HXF2-L	37	76404	EST-S	17	76488	TRB36	23
75887	CDWB42	118	76024	MAPEK	134	76405	EST-B	17	76488	TRB36	25
75888	CDWB48	118	76025	MCBK	169	76406	ESTAK	17	76488	TRB36	27
75889	CDWB54	118	76025	MCBK	169	76406	ESTAK	112	76489	TRB42	23
75890	CDWB60	118	76026	MCBKHD	169	76406	ESTAK-EST	43	76489	TRB42	25
75891	CDWB72	118	76026	MCBKHD	169	76407	ESPSBK	17	76489	TRB42	27
75892	STAKHD	78	76027	HSA200-EL15	50	76408	ESPBK	17	76490	TRB48	23
75892	STAKHD	78	76027	HSA200-EL15	54	76409	ESPRK	17	76490	TRB48	25
75892	STAKHD	99	76027	HSA200-EL15	55	76410	ESBK-PS	17	76490	TRB48	27
75892	STAKHD	101	76069	AWTNCB	26	76410	ESBK-PS	18	76491	TRB54	23
75892	STAKHD	117	76069	AWTNCB	32	76411	ESBK-B	17	76491	TRB54	25
75892	STAKHD	117	76071	SSTSMB	134	76411	ESBK-B	18	76491	TRB54	27
75895	PMB	32	76072	SSTLMB	134	76411	ESBK-B EST	18	76492	TRB60	23
75896	PSTA	25	76074	QMT-P	25	76412	ESS-S	17	76492	TRB60	25
75896	PSTA	32	76075	QMT-W	25	76412	ESS-S	112	76492	TRB60	27
75897	PTPK	32	76096	QMTPAK	25	76413	ESS-B	17	76493	TRB66	23
75898	PSTS-W	25	76097	QMTBK-P	25	76415	RMC1-BPP	171	76493	TRB66	25
75898	PSTS-W	32	76097	QMTBK-P	27	76442	CBD-S	156	76493	TRB66	27
75898	PSTS-W	35	76098	QMTBK-W	25	76443	CBD-M	156	76494	TRB72	23
75898	PSTS-W	112	76098	QMTBK-W	27	76444	CBD-L	156	76494	TRB72	25
75899	PSTS-S	32	76098	QMTBK-W	32	76445	CBD-XL	156	76494	TRB72	27
75899	PSTS-S	35	76098	QMTBK-W	35	76446	DBK-S	156	76540	QMTBK-G	25
75899	PSTS-S	43	76099	QMTPSBK	25	76447	DBK-M	156	76540	QMTBK-G	27
75904	AWT	26	76205	RVT6-S/S	68	76448	DBK-L	156	76558	RMC-FS	171
75904	AWT	32	76205	RVT6-S/S	69	76449	DBK-XL	156	76559	RMC2-AP	171
75905	AWTB	26	76205	RVT6-S/S	71	76450	MMP-624	23	76593	CRB-HT10	19
75905	AWTB	32	76205	RVT6-S/S	73	76451	MMP-630	23	76594	CRB-HT16	19
75906	AWTMB	26	76205	RVT6-S/S	76	76452	MMP-636	23	76595	CRB-HT22	19
75906	AWTMB	32	76205	RVT6-S/S	78	76453	MMP-642	23	76596	CRB-HT28	19
75907	AWTA	26	76205	RVT6-S/S	94	76454	MMP-648	23	76597	CRB-HT34	19
75907	AWTA	32	76205	RVT6-S/S	101	76455	MMP-654	23	76598	CRB-HT40	19

INDEX By Item Code

Item Code	Ordering Number	Page #	Item Code	Ordering Number	Page #	Item Code	Ordering Number	Page #	Item Code	Ordering Number	Page #
76599	CRB-HT46	19	76739	URVB36/900	114	76828	DRXL-48-520	145	76896	DRXH-24-435	147
76600	CRB-HT52	19	76740	URVB42/1050	110	76829	DRXL-54-520	145	76897	DRXH-30-435	147
76601	CRB-HT58	19	76740	URVB42/1050	110	76830	DRXL-60-520	145	76898	DRXH-36-435	147
76602	CRB-HT64	19	76740	URVB42/1050	111	76831	DRXL-72-520	145	76899	DRXH-42-435	147
76603	CRB-HT70	19	76740	URVB42/1050	111	76832	DRXL-24-435	145	76900	DRXH-48-435	147
76636	SSTBK-W	78	76740	URVB42/1050	114	76833	DRXL-30-435	145	76901	DRXH-54-435	147
76636	SSTBK-W	78	76741	URVB48/1200	110	76834	DRXL-36-435	145	76902	DRXH-60-435	147
76636	SSTBK-W	99	76741	URVB48/1200	110	76835	DRXL-42-435	145	76903	DRXH-72-435	147
76636	SSTBK-W	101	76741	URVB48/1200	111	76836	DRXL-48-435	145	76904	DRXH-24-535	147
76636	SSTBK-W	117	76741	URVB48/1200	111	76837	DRXL-54-435	145	76905	DRXH-30-535	147
76636	SSTBK-W	117	76741	URVB48/1200	114	76838	DRXL-60-435	145	76906	DRXH-36-535	147
76636	SSTBK-W	118	76742	URVB54/1350	110	76839	DRXL-72-435	145	76907	DRXH-42-535	147
76637	SSTBK-B	78	76742	URVB54/1350	110	76840	DRXL-24-535	145	76908	DRXH-48-535	147
76637	SSTBK-B	78	76742	URVB54/1350	111	76841	DRXL-30-535	145	76909	DRXH-54-535	147
76637	SSTBK-B	99	76742	URVB54/1350	111	76842	DRXL-36-535	145	76910	DRXH-60-535	147
76637	SSTBK-B	101	76742	URVB54/1350	114	76843	DRXL-42-535	145	76911	DRXH-72-535	147
76637	SSTBK-B	117	76743	URVB60/1500	110	76844	DRXL-48-535	145	76912	DRXD-42-520	148
76637	SSTBK-B	117	76743	URVB60/1500	110	76845	DRXL-54-535	145	76913	DRXD-48-520	148
76638	MHCP-2BC24	32	76743	URVB60/1500	111	76846	DRXL-60-535	145	76914	DRXD-54-520	148
76639	MHCP-2BC30	32	76743	URVB60/1500	111	76847	DRXL-72-535	145	76915	DRXD-60-520	148
76640	MHCP-2BC36	32	76743	URVB60/1500	114	76848	DRXM-24-420	146	76916	DRXD-72-520	148
76641	MHCP-2BC42	32	76744	URVB72/1800	110	76849	DRXM-30-420	146	76917	DRXD-84-520	148
76642	MHCP-2BC48	32	76744	URVB72/1800	110	76850	DRXM-36-420	146	76918	DRXD-96-520	148
76643	MHCP-2BC54	32	76744	URVB72/1800	111	76851	DRXM-42-420	146	76919	DRXD-42-535	148
76644	MHCP-2BC60	32	76744	URVB72/1800	111	76852	DRXM-48-420	146	76920	DRXD-48-535	148
76645	MHCP-2BC72	32	76744	URVB72/1800	114	76853	DRXM-54-420	146	76921	DRXD-54-535	148
76658	HTF212	15	76745	URVB84/2100	110	76854	DRXM-60-420	146	76922	DRXD-60-535	148
76659	HTF218	15	76745	URVB84/2100	110	76855	DRXM-72-420	146	76923	DRXD-72-535	148
76660	HTF224	15	76745	URVB84/2100	111	76856	DRXM-24-520	146	76924	DRXD-84-535	148
76661	HTF230	15	76745	URVB84/2100	111	76857	DRXM-30-520	146	76925	DRXD-96-535	148
76662	HTF236	15	76745	URVB84/2100	114	76858	DRXM-36-520	146	76926	IB4	139
76663	HTF242	15	76748	URCB18/450	114	76859	DRXM-42-520	146	76926	IB4	141
76664	HTF248	15	76749	URCB24/600	114	76860	DRXM-48-520	146	76926	IB4	143
76665	HTF254	15	76750	URCB30/750	114	76861	DRXM-54-520	146	76926	IB4	145
76666	HTF260	15	76751	URCB36/900	114	76862	DRXM-60-520	146	76926	IB4	146
76667	HTF272	15	76752	URCB42/1050	114	76863	DRXM-72-520	146	76926	IB4	147
76668	CBC18	123	76753	URCB48/1200	114	76864	DRXM-24-435	146	76927	IB5	139
76669	CBC24	123	76754	URCB54/1350	114	76865	DRXM-30-435	146	76927	IB5	141
76670	CBC30	123	76755	URCB60/1500	114	76866	DRXM-36-435	146	76927	IB5	143
76671	CBC36	123	76756	URCB72/1800	114	76867	DRXM-42-435	146	76927	IB5	145
76672	CBC42	123	76757	URCB84/2100	114	76868	DRXM-48-435	146	76927	IB5	146
76673	CBC48	123	76787	UHPB	112	76869	DRXM-54-435	146	76927	IB5	147
76674	CBC54	123	76787	UHPB	113	76870	DRXM-60-435	146	76927	IB5	148
76675	CBC60	123	76788	ABU	112	76871	DRXM-72-435	146	76928	IBBK	145
76692	CPB	123	76788	ABU	112	76872	DRXM-24-535	146	76928	IBBK	146
76695	MSPP66	117	76788	ABU	113	76873	DRXM-30-535	146	76928	IBBK	147
76697	TRB78	23	76788	ABU	113	76874	DRXM-36-535	146	76928	IBBK	148
76697	TRB78	25	76790	USPK	112	76875	DRXM-42-535	146	76929	IBS-L4	145
76697	TRB78	27	76798	MMP-684	23	76876	DRXM-48-535	146	76930	IBS-L5	145
76736	URVB18/450	110	76800	MHCP-84S	30	76877	DRXM-54-535	146	76931	IBS-M4	146
76736	URVB18/450	110	76801	MHCP-84A	30	76878	DRXM-60-535	146	76932	IBS-M5	146
76736	URVB18/450	111	76806	MDWS-84	116	76879	DRXM-72-535	146	76933	IBS-H4	147
76736	URVB18/450	111	76808	MMPCP84	25	76880	DRXH-24-420	147	76934	IBS-DH5	147
76736	URVB18/450	114	76811	MHP-CP2100	32	76881	DRXH-30-420	147	76934	IBS-DH5	148
76737	URVB24/600	110	76812	MHCP-2BC84	32	76882	DRXH-36-420	147	76935	ISABK	148
76737	URVB24/600	110	76815	DWP84	117	76883	DRXH-42-420	147	76936	IMK	145
76737	URVB24/600	111	76816	DRXL-24-420	145	76884	DRXH-48-420	147	76936	IMK	146
76737	URVB24/600	111	76817	DRXL-30-420	145	76885	DRXH-54-420	147	76936	IMK	147
76737	URVB24/600	114	76818	DRXL-36-420	145	76886	DRXH-60-420	147	76937	IEA42-60D	148
76738	URVB30/750	110	76819	DRXL-42-420	145	76887	DRXH-72-420	147	76938	IEA72-96D	148
76738	URVB30/750	110	76820	DRXL-48-420	145	76888	DRXH-24-520	147	76939	HW-IMPB	149
76738	URVB30/750	111	76821	DRXL-54-420	145	76889	DRXH-30-520	147	76942	CDWB84	118
76738	URVB30/750	111	76822	DRXL-60-420	145	76890	DRXH-36-520	147	76950	OIBBK	149
76738	URVB30/750	114	76823	DRXL-72-420	145	76891	DRXH-42-520	147	76965	IB4-1U	149
76739	URVB36/900	110	76824	DRXL-24-520	145	76892	DRXH-48-520	147	76966	IB5-1U	149
76739	URVB36/900	110	76825	DRXL-30-520	145	76893	DRXH-54-520	147	76979	FLM	176
76739	URVB36/900	111	76826	DRXL-36-520	145	76894	DRXH-60-520	147	76980	FLL	176
76739	URVB36/900	111	76827	DRXL-42-520	145	76895	DRXH-72-520	147	76983	FLXL	176

INDEX By Item Code

Item Code	Ordering Number	Page #	Item Code	Ordering Number	Page #	Item Code	Ordering Number	Page #	Item Code	Ordering Number	Page #
76984	FLVRL-XL	176	77131	EZP-LS236	10	77316	URVB88/2200	110	77420	USP98/2500-S/S	113
76985	FLTW-XL	176	77132	EZP-LS242	10	77316	URVB88/2200	110	77421	URVB94/2400	110
76986	FLELK-XL	176	77133	EZP-LS248	10	77316	URVB88/2200	111	77421	URVB94/2400	110
77031	CSTAK	99	77134	EZP-LS254	10	77316	URVB88/2200	111	77421	URVB94/2400	111
77031	CSTAK	101	77135	EZP-LS260	10	77316	URVB88/2200	114	77421	URVB94/2400	111
77037	CSTBK	99	77144	CLSFG-212	10	77317	URCB56/1400	114	77421	URVB94/2400	114
77037	CSTBK	101	77145	CLSFG-218	10	77318	URCB64/1600	114	77422	URVB98/2500	110
77047	TRB84	25	77146	CLSFG-224	10	77320	URVB80/2000	110	77422	URVB98/2500	110
77047	TRB84	27	77147	CLSFG-230	10	77320	URVB80/2000	110	77422	URVB98/2500	111
77048	TRB90	25	77148	CLSFG-236	10	77320	URVB80/2000	111	77422	URVB98/2500	111
77048	TRB90	27	77149	CLSFG-242	10	77320	URVB80/2000	111	77422	URVB98/2500	114
77052	SACSK	99	77150	CLSFG-248	10	77320	URVB80/2000	114	77424	MMP-624-S/S	24
77052	SACSK	101	77151	CLSFG-254	10	77321	URCB80/2000	114	77425	MMP-630-S/S	24
77065	SACSRC	99	77152	CLSFG-260	10	77324	MMKU	112	77426	MMP-636-S/S	24
77065	SACSRC	101	77250	FL-PKIT-ML	176	77327	MMKUHD	112	77427	MMP-642-S/S	24
77070	LSP12	12	77251	FL-PKIT-XL	176	77329	HDARK	112	77428	MMP-648-S/S	24
77071	LSP18	12	77259	UTV450J-S/S	111	77331	HDARK-S/S	113	77429	MMP-654-S/S	24
77072	LSP24	12	77260	UTV600J-S/S	111	77339	USP18/450-S/S	113	77430	MMP-660-S/S	24
77073	LSP30	12	77261	UTV750J-S/S	111	77340	USP24/600-S/S	113	77431	MMP-672-S/S	24
77074	LSP36	12	77262	UTV900J-S/S	111	77341	USP30/750-S/S	113	77432	MMP-684-S/S	24
77075	LSP42	12	77263	UTV1050J-S/S	111	77342	USP36/900-S/S	113	77442	PSTA-S/S	27
77076	LSP48	12	77264	UTV1200J-S/S	111	77343	USP42/1050-S/S	113	77443	TEN-LOCK-KIT	22
77077	LSP54	12	77265	UTV1350J-S/S	111	77344	USP48/1200-S/S	113	77443	TEN-LOCK-KIT	81
77078	LSP60	12	77266	UTV1400J-S/S	111	77345	USP54/1350-S/S	113	77443	TEN-LOCK-KIT	109
77079	LSP12-S/S	13	77267	UTV1500J-S/S	111	77346	USP56/1400-S/S	113	77448	URCB94/2400	114
77080	LSP18-S/S	13	77268	UTV1600J-S/S	111	77347	USP60/1500-S/S	113	77449	URCB98/2500	114
77081	LSP24-S/S	13	77269	UTV1800J-S/S	111	77348	USP64/1600-S/S	113	77450	QMTS-P-S/S	18
77082	LSP30-S/S	13	77270	UTV2000J-S/S	111	77349	USP72/1800-S/S	113	77450	QMTS-P-S/S	27
77083	LSP36-S/S	13	77271	UTV2100J-S/S	111	77350	USP80/2000-S/S	113	77450	QMTS-P-SS	113
77084	LSP42-S/S	13	77272	UTV2200J-S/S	111	77351	USP84/2100-S/S	113	77451	QMTS-W-S/S	18
77085	LSP48-S/S	13	77283	UTV450-J	111	77352	USP88/2200-S/S	113	77451	QMTS-W-S/S	113
77086	LSP54-S/S	13	77284	UTV600-J	111	77357	MMKU-SS	113	77451	QSTS-W-S/S	27
77087	LSP60-S/S	13	77285	UTV750-J	111	77358	MMKUHD-SS	113	77452	QMTS-G-S/S	18
77088	CRB-LS10	14	77286	UTV900-J	111	77364	HARK-S/S	113	77452	QMTS-G-S/S	27
77089	CRB-LS16	14	77287	UTV1050-J	111	77365	LS-SP	12	77452	QMTS-G-SS	113
77090	CRB-LS22	14	77288	UTV1200-J	111	77366	LSTMPK	12	77473	MSPP30-S/S	117
77091	CRB-LS28	14	77289	UTV1350-J	111	77367	LSTPB-RK	12	77474	MSPP36-S/S	117
77092	CRB-LS34	14	77290	UTV1400-J	111	77367	LSTPB-RK	13	77475	MSPP42-S/S	117
77093	CRB-LS40	14	77291	UTV1500-J	111	77384	EZPTBT	21	77476	MSPP48-S/S	117
77094	CRB-LS46	14	77292	UTV1600-J	111	77385	EZPTBTHD	21	77477	MSPP54-S/S	117
77095	CRB-LS52	14	77293	UTV1800-J	111	77387	SPG-CVR-A	22	77478	MSPP60-S/S	117
77096	CRB-LS58	14	77294	UTV2000-J	111	77387	SPG-CVR-A	81	77479	MSPP66-S/S	117
77097	CRB-LS10W	14	77295	UTV2100-J	111	77387	SPG-CVR-A	109	77481	MHS-600BTV	75
77098	CRB-LS16W	14	77296	UTV2200-J	111	77388	SPG-CVR-B	22	77482	MHS-750BTV	75
77099	CRB-LS22W	14	77297	UTV450	110	77388	SPG-CVR-B	81	77483	MHS-900BTV	75
77100	CRB-LS28W	14	77298	UTV600	110	77388	SPG-CVR-B	109	77484	MHS-1050BTV	75
77101	CRB-LS34W	14	77299	UTV750	110	77389	SPG-CVR-C	22	77485	MHS-1350BTV	75
77102	CRB-LS40W	14	77300	UTV900	110	77389	SPG-CVR-C	81	77486	MHS-1500BTV	75
77103	CRB-LS46W	14	77301	UTV1050	110	77389	SPG-CVR-C	109	77487	MHS-1800BTV	75
77104	CRB-LS52W	14	77302	UTV1200	110	77390	SPG-CVR-D	22	77488	MHS-2100BTV	75
77105	CRB-LS58W	14	77303	UTV1350	110	77390	SPG-CVR-D	81	77489	MHS-2400BTV	75
77114	LS-BP	12	77304	UTV1400	110	77390	SPG-CVR-D	109	77490	MHS-600BTV-S/S	75
77115	LS-BP-S/S	13	77305	UTV1500	110	77391	SPG-CVR-E	22	77491	MHS-750BTV-S/S	75
77117	LS-SW	12	77306	UTV1600	110	77391	SPG-CVR-E	81	77492	MHS-900BTV-S/S	75
77118	LS-SS	12	77307	UTV1800	110	77391	SPG-CVR-E	109	77493	MHS-1050BTV-S/S	75
77118	LS-SS	13	77308	UTV2000	110	77392	SPG-CVR-F	22	77494	MHS-1350BTV-S/S	75
77120	LST-TAK	12	77309	UTV2100	110	77392	SPG-CVR-F	81	77495	MHS-1500BTV-S/S	75
77120	LST-TAK	13	77310	UTV2200	110	77392	SPG-CVR-F	109	77496	MHS-1800BTV-S/S	75
77121	LST-P	12	77314	URVB56/1400	110	77393	SPG-CVR-G	22	77497	MHS-2100BTV-S/S	75
77122	LST-W	12	77314	URVB56/1400	110	77393	SPG-CVR-G	81	77498	MHS-2400BTV-S/S	75
77123	LST-S	12	77314	URVB56/1400	111	77393	SPG-CVR-G	109	77499	MHS-P600	71
77124	LST-B-S/S	13	77314	URVB56/1400	111	77411	UTV2400	110	77499	MHS-P600	73
77125	LST-W-S/S	13	77314	URVB56/1400	114	77412	UTV2500	110	77499	MHS-P600	78
77126	LST-W-S/S-2	13	77315	URVB64/1600	110	77413	UTV2400-J	111	77499	MHS-P600	76
77127	EZP-LS212	10	77315	URVB64/1600	110	77414	UTV2500-J	111	77500	MHS-P750	71
77128	EZP-LS218	10	77315	URVB64/1600	111	77417	UTV2400J-S/S	111	77500	MHS-P750	73
77129	EZP-LS224	10	77315	URVB64/1600	111	77418	UTV2500J-S/S	111	77500	MHS-P750	78
77130	EZP-LS230	10	77315	URVB64/1600	114	77419	USP94/2400-S/S	113	77500	MHS-P750	76

INDEX By Item Code

Item Code	Ordering Number	Page #	Item Code	Ordering Number	Page #	Item Code	Ordering Number	Page #	Item Code	Ordering Number	Page #
77501	MHS-P900	71	77525	MHS-1200BTV	75	77633	STHDPM2-S/S	101	77795	MHS-1500FPV	77
77501	MHS-P900	73	77526	MHS-1200BTV-S/S	75	77633	STHDPM2-S/S	117	77796	MHS-1800FPV	77
77501	MHS-P900	78	77527	MHS-P1200	71	77634	STHDMK2-S/S	78	77797	MHS-2100FPV	77
77501	MHS-P900*	76	77527	MHS-P1200	73	77634	STHDMK2-S/S	101	77798	MHS-2400FPV	77
77502	MHS-P1050	71	77527	MHS-P1200	78	77634	STHDMK2-S/S	117	77799	MHS-600FPV-S/S	77
77502	MHS-P1050	73	77527	MHS-P1200*	76	77635	STGK2	78	77800	MHS-750FPV-S/S	77
77502	MHS-P1050	78	77528	MHS-P1200S/S	71	77635	STGK2	78	77801	MHS-900FPV-S/S	77
77502	MHS-P1050	76	77528	MHS-P1200S/S	73	77635	STGK2	99	77802	MHS-1050FPV-S/S	77
77503	MHS-P1350	71	77528	MHS-P1200S/S	78	77635	STGK2	101	77803	MHS-1200FPV-S/S	77
77503	MHS-P1350	73	77528	MHS-P1200S/S	76	77635	STGK2	117	77804	MHS-1350FPV-S/S	77
77503	MHS-P1350	78	77529	ISABK-LMH	145	77635	STGK2	117	77805	MHS-1500FPV-S/S	77
77503	MHS-P1350	76	77529	ISABK-LMH	146	77664	PTS-18R	164	77806	MHS-1800FPV-S/S	77
77504	MHS-P1500	71	77529	ISABK-LMH	147	77665	PTS-24R	164	77807	MHS-2100FPV-S/S	77
77504	MHS-P1500	73	77548	SHIM-KITL	145	77666	PTS-30R	164	77808	MHS-2400FPV-S/S	77
77504	MHS-P1500	78	77549	SHIM-KITM	146	77667	PTS-36R	164	77866	SAC2-TIP-TL	85
77504	MHS-P1500	76	77550	SHIM-KITH	147	77668	PTS-42R	164	77866	SAC2-TIP-TL	87
77505	MHS-P1800	71	77552	CRB-LS16HT	14	77669	PTS-48R	164	77866	SAC2-TIP-TL	92
77505	MHS-P1800	73	77553	CRB-LS22HT	14	77670	PTS-54R	164	77866	SAC2-TIP-TL	94
77505	MHS-P1800	78	77554	CRB-LS28HT	14	77671	PTS-60R	164	77866	SAC2-TIP-TL	99
77505	MHS-P1800	76	77555	CRB-LS34HT	14	77672	PTS-72R	164	77866	SAC2-TIP-TL	101
77506	MHS-P2100	73	77556	CRB-LS40HT	14	77680	PTS-RR21	164	77866	SAC2-TIP-TL	105
77506	MHS-P2100	78	77557	CRB-LS46HT	14	77681	PTS-RR27	164	77866	SAC2-TIP-TL	107
77506	MHS-P2100	76	77558	CRB-LS52HT	14	77682	PTS-RR33	164	77868	SSTHDPM	78
77507	MHS-P2400	73	77582	MSPMPK-S/S	27	77683	PTS-RR39	164	77868	SSTHDPM	99
77507	MHS-P2400	78	77583	MSPBPK-S/S	18	77684	PTS-RR45	164	77868	SSTHDPM	117
77507	MHS-P2400	76	77584	QMT-P-S/S	27	77685	PTS-RR51	164	77869	CSTHDPM	99
77508	MHS-P600S/S	71	77585	QMT-W-S/S	27	77686	PTS-RR57	164	77870	SSTHDMK	78
77508	MHS-P600S/S	73	77586	QMT-G-S/S	27	77687	PTS-RR63	164	77870	SSTHDMK	98
77508	MHS-P600S/S	78	77587	QMTPAK-S/S	27	77689	PTS-RR75	164	77870	SSTHDMK	117
77508	MHS-P600S/S	76	77588	QMTPSBK-S/S	27	77691	PTS-SR	165	77871	CSTHDMK	99
77509	MHS-P750S/S	71	77590	MMPCP24-S/S	27	77692	PTS-HDSR	165	77882	SACRKN	48
77509	MHS-P750S/S	73	77591	MMPCP30-S/S	27	77693	PTS-ABK	165	77882	SACRKN	85
77509	MHS-P750S/S	78	77592	MMPCP36-S/S	27	77694	PTS-SAK	165	77882	SACRKN	87
77509	MHS-P750S/S	76	77593	MMPCP42-S/S	27	77696	PTS-IBK	165	77882	SACRKN	92
77510	MHS-P900S/S	71	77594	MMPCP48-S/S	27	77697	PTS-HIBK	165	77882	SACRKN	94
77510	MHS-P900S/S	73	77595	MMPCP54-S/S	27	77698	PTS-PS	165	77882	SACRKN	99
77510	MHS-P900S/S	78	77596	MMPCP60-S/S	27	77699	PTS-PA	165	77882	SACRKN	101
77510	MHS-P900S/S	76	77597	MMPCP72-S/S	27	77700	PTS-MBK	165	77882	SACRKN	105
77511	MHS-P1050S/S	71	77598	MMPCP84-S/S	27	77701	PTS-MBKUG	165	77882	SACRKN	107
77511	MHS-P1050S/S	73	77599	MHP-EP-S/S	27	77702	PTS-EBK	165	77883	SACRH	48
77511	MHS-P1050S/S	78	77599	MHP-EP-S/S	49	77723	PST2-W	32	77883	SACRH	85
77511	MHS-P1050S/S	76	77599	MHP-EP-S/S	55	77724	PST2-S	32	77883	SACRH	92
77512	MHS-P1350S/S	71	77599	MHP-EP-S/S	86	77729	FLCK	176	77883	SACRH	99
77512	MHS-P1350S/S	73	77599	MHP-EP-S/S	93	77741	SPG-CVR-H	22	77883	SACRH	105
77512	MHS-P1350S/S	78	77599	MHP-EP-S/S	100	77741	SPG-CVR-H	81	77884	SACRHL	48
77512	MHS-P1350S/S	76	77599	MHP-EP-S/S	106	77741	SPG-CVR-H	109	77884	SACRHL	85
77513	MHS-P1500S/S	71	77600	MMPBPK-S/S	27	77742	CTS-W	99	77884	SACRHL	92
77513	MHS-P1500S/S	73	77630	STS-W-S/S	71	77743	CTS-S	62	77884	SACRHL	99
77513	MHS-P1500S/S	78	77630	STS-W-S/S	73	77743	CTS-S	99	77884	SACRHL	105
77513	MHS-P1500S/S	76	77630	STS-W-S/S	78	77744	CTS-B	99	77885	SACKRP	48
77514	MHS-P1800S/S	71	77630	STS-W-S/S	101	77745	CTS-G	99	77885	SACKRP	85
77514	MHS-P1800S/S	73	77630	STS-W-S/S	117	77746	EZP-LS212HT	10	77885	SACKRP	92
77514	MHS-P1800S/S	78	77630	STS-W-S/S	117	77747	EZP-LS218HT	10	77885	SACKRP	99
77514	MHS-P1800S/S	76	77631	STS-S-S/S	71	77748	EZP-LS224HT	10	77885	SACKRP	105
77515	MHS-P2100S/S	73	77631	STS-S-S/S	73	77749	EZP-LS230HT	10	77886	SACRKT	85
77515	MHS-P2100S/S	78	77631	STS-S-S/S	78	77750	EZP-LS236HT	10	77886	SACRKT	92
77515	MHS-P2100S/S	76	77631	STS-S-S/S	101	77751	EZP-LS242HT	10	77886	SACRKT	99
77516	MHS-P2400S/S	73	77631	STS-S-S/S	117	77752	EZP-LS248HT	10	77886	SACRKT	105
77516	MHS-P2400S/S	78	77631	STS-S-S/S	117	77753	EZP-LS254HT	10	77887	SACPL-24/600	84
77516	MHS-P2400S/S	76	77632	STS-B-S/S	43	77754	EZP-LS260HT	10	77887	SACPL-24/600	91
77518	HXF8SS-Blue	36	77632	STS-B-S/S	43	77755	PTS-RHSAA	165	77887	SACPL-24/600	98
77518	HXF8SS-Blue	37	77632	STS-B-S/S	71	77756	PTS-LHSAA	165	77887	SACPL-24/600	105
77519	HXF8S-Blue	36	77632	STS-B-S/S	73	77789	MHS-600FPV	77	77888	SACPL-30/750	84
77519	HXF8S-Blue	37	77632	STS-B-S/S	78	77790	MHS-750FPV	77	77888	SACPL-30/750	91
77520	HXF8M-Blue	36	77632	STS-B-S/S	101	77791	MHS-900FPV	77	77888	SACPL-30/750	98
77520	HXF8M-Blue	37	77632	STS-B-S/S	117	77792	MHS-1050FPV	77	77888	SACPL-30/750	105
77521	HXF8L-Blue	36	77632	STS-B-S/S	117	77793	MHS-1200FPV	77	77889	SACPL-36/900	84
77521	HXF8L-Blue	37	77633	STHDPM2-S/S	78	77794	MHS-1350FPV	77	77889	SACPL-36/900	91

INDEX By Item Code

Item Code	Ordering Number	Page #	Item Code	Ordering Number	Page #	Item Code	Ordering Number	Page #	Item Code	Ordering Number	Page #
77889	SACPL-36/900	98	77942	MHS-CARK-V54/1350	97	78106	R-CARK-V24/600	90	78350	RV1500-2SAC-S/S	89
77889	SACPL-36/900	105	77942	MHS-CARK-V54/1350	104	78107	R-CARK-V30/750	90	78351	RV1800-2SAC-S/S	89
77890	SACPL-42/1050	84	77943	MHS-CARK-V60/1500	97	78108	R-CARK-V36/900	90	78352	RV2100-2SAC-S/S	89
77890	SACPL-42/1050	91	77943	MHS-CARK-V60/1500	104	78109	R-CARK-V42/1050	90	78353	RV2400-2SAC-S/S	89
77890	SACPL-42/1050	98	77944	MHS-CARK-V72/1800	97	78110	R-CARK-V48/1200	90	78354	RV3000-2SAC-S/S	89
77890	SACPL-42/1050	105	77944	MHS-CARK-V72/1800	104	78111	R-CARK-V54/1350	90	78355	PCAP-24/600-S/S	87
77891	SACPL-48/1200	84	77950	MHS-CARK2-V60/1500	97	78112	R-CARK-V60/1500	90	78356	PCAP-30/750-S/S	87
77891	SACPL-48/1200	91	77950	MHS-CARK2-V60/1500	104	78113	R-CARK-V72/1800	90	78357	PCAP-36/900-S/S	87
77891	SACPL-48/1200	98	77951	MHS-CARK2-V72/1800	97	78119	R-CARK2-V60/1500	90	78358	PCAP-42/1050-S/S	87
77891	SACPL-48/1200	105	77951	MHS-CARK2-V72/1800	104	78120	R-CARK2-V72/1800	90	78359	PCAP-48/1200-S/S	87
77892	SACPL-54/1350	84	77952	MHS-CARK2-V84/2100	97	78121	R-CARK2-V84/2100	90	78360	PCAP-54/1350-S/S	87
77892	SACPL-54/1350	91	77952	MHS-CARK2-V84/2100	104	78122	R-CARK2-V96/2400	90	78361	PCAP-60/1500-S/S	87
77892	SACPL-54/1350	98	77953	MHS-CARK2-V96/2400	97	78123	R-CARK2-V120/3000	90	78362	PCAP-72/1800-S/S	87
77892	SACPL-54/1350	105	77953	MHS-CARK2-V96/2400	104	78142	STS-G	43	78363	RCAP-24/600-S/S	94
77893	SACPL-60/1500	84	77954	MHS-CARK2-V120/3000	97	78142	STS-G	43	78364	RCAP-30/750-S/S	94
77893	SACPL-60/1500	91	77954	MHS-CARK2-V120/3000	104	78142	STS-G	71	78365	RCAP-36/900-S/S	94
77893	SACPL-60/1500	98	78007	MHS-600BTB-SAC	103	78142	STS-G	73	78366	RCAP-42/1050-S/S	94
77893	SACPL-60/1500	105	78008	MHS-750BTB-SAC	103	78142	STS-G	78	78367	RCAP-48/1200-S/S	94
77894	SACPL-72/1800	84	78009	MHS-900BTB-SAC	103	78142	STS-G	99	78368	RCAP-54/1350-S/S	94
77894	SACPL-72/1800	91	78010	MHS-1050BTB-SAC	103	78142	STS-G	117	78369	RCAP-60/1500-S/S	94
77894	SACPL-72/1800	98	78011	MHS-1200BTB-SAC	103	78142	STS-G	117	78370	RCAP-72/1800-S/S	94
77894	SACPL-72/1800	105	78012	MHS-1350BTB-SAC	103	78162	MHS-600V-SAC	96	78371	SACPL-24/600-S/S	86
77895	SACPL2-60/1500	84	78013	MHS-1500BTB-SAC	103	78163	MHS-750V-SAC	96	78371	SACPL-24/600-S/S	93
77895	SACPL2-60/1500	91	78014	MHS-1800BTB-SAC	103	78164	MHS-900V-SAC	96	78371	SACPL-24/600-S/S	100
77895	SACPL2-60/1500	98	78015	MHS-1500BTB-2SAC	103	78165	MHS-1050V-SAC	96	78371	SACPL-24/600-S/S	106
77895	SACPL2-60/1500	105	78016	MHS-1800BTB-2SAC	103	78166	MHS-1200V-SAC	96	78372	SACPL-30/750-S/S	86
77896	SACPL2-72/1800	84	78017	MHS-2100BTB-2SAC	103	78167	MHS-1350V-SAC	96	78372	SACPL-30/750-S/S	93
77896	SACPL2-72/1800	91	78018	MHS-2400BTB-2SAC	103	78168	MHS-1500V-SAC	96	78372	SACPL-30/750-S/S	100
77896	SACPL2-72/1800	98	78019	MHS-3000BTB-2SAC	103	78169	MHS-1800V-SAC	96	78372	SACPL-30/750-S/S	106
77896	SACPL2-72/1800	105	78020	PV600-SAC	82	78170	MHS-1500V-2SAC	96	78373	SACPL-36/900-S/S	86
77897	SACPL2-84/2100	84	78021	PV750-SAC	82	78171	MHS-1800V-2SAC	96	78373	SACPL-36/900-S/S	93
77897	SACPL2-84/2100	91	78022	PV900-SAC	82	78172	MHS-2100V-2SAC	96	78373	SACPL-36/900-S/S	100
77897	SACPL2-84/2100	98	78023	PV1050-SAC	82	78173	MHS-2400V-2SAC	96	78373	SACPL-36/900-S/S	106
77897	SACPL2-84/2100	105	78024	PV1200-SAC	82	78174	MHS-3000V-2SAC	96	78374	SACPL-42/1050-S/S	86
77898	SACPL2-96/2400	84	78025	PV1350-SAC	82	78316	MHS-600BTB-SAC-S/S	103	78374	SACPL-42/1050-S/S	93
77898	SACPL2-96/2400	91	78026	PV1500-SAC	82	78317	MHS-750BTB-SAC-S/S	103	78374	SACPL-42/1050-S/S	100
77898	SACPL2-96/2400	98	78027	PV1800-SAC	82	78318	MHS-900BTB-SAC-S/S	103	78374	SACPL-42/1050-S/S	106
77898	SACPL2-96/2400	105	78028	PV1500-2SAC	82	78319	MHS-1050BTB-SAC-S/S	103	78375	SACPL-48/1200-S/S	86
77899	SACPL2-120/3000	84	78029	PV1800-2SAC	82	78320	MHS-1200BTB-SAC-S/S	103	78375	SACPL-48/1200-S/S	93
77899	SACPL2-120/3000	91	78030	PV2100-2SAC	82	78321	MHS-1350BTB-SAC-S/S	103	78375	SACPL-48/1200-S/S	100
77899	SACPL2-120/3000	98	78031	PV2400-2SAC	82	78322	MHS-1500BTB-SAC-S/S	103	78375	SACPL-48/1200-S/S	106
77899	SACPL2-120/3000	105	78032	PV3000-2SAC	82	78323	MHS-1800BTB-SAC-S/S	103	78376	SACPL-54/1350-S/S	86
77913	PCAP-24/600	85	78033	RV600-SAC	89	78324	MHS-1500BTB-2SAC-S/S	103	78376	SACPL-54/1350-S/S	93
77914	PCAP-30/750	85	78034	RV750-SAC	89	78325	MHS-1800BTB-2SAC-S/S	103	78376	SACPL-54/1350-S/S	100
77915	PCAP-36/900	85	78035	RV900-SAC	89	78326	MHS-2100BTB-2SAC-S/S	103	78376	SACPL-54/1350-S/S	106
77916	PCAP-42/1050	85	78036	RV1050-SAC	89	78327	MHS-2400BTB-2SAC-S/S	103	78377	SACPL-60/1500-S/S	86
77917	PCAP-48/1200	85	78037	RV1200-SAC	89	78328	MHS-3000BTB-2SAC-S/S	103	78377	SACPL-60/1500-S/S	93
77918	PCAP-54/1350	85	78038	RV1350-SAC	89	78329	PV600-SAC-S/S	82	78377	SACPL-60/1500-S/S	100
77919	PCAP-60/1500	85	78039	RV1500-SAC	89	78330	PV750-SAC-S/S	82	78377	SACPL-60/1500-S/S	106
77920	PCAP-72/1800	85	78040	RV1800-SAC	89	78331	PV900-SAC-S/S	82	78378	SACPL-72/1800-S/S	86
77921	RCAP-24/600	92	78041	RV1500-2SAC	89	78332	PV1050-SAC-S/S	82	78378	SACPL-72/1800-S/S	93
77922	RCAP-30/750	92	78042	RV1800-2SAC	89	78333	PV1200-SAC-S/S	82	78378	SACPL-72/1800-S/S	100
77923	RCAP-36/900	92	78043	RV2100-2SAC	89	78334	PV1350-SAC-S/S	82	78378	SACPL-72/1800-S/S	106
77924	RCAP-42/1050	92	78044	RV2400-2SAC	89	78335	PV1500-SAC-S/S	82	78379	SACPL2-60/1500-S/S	86
77925	RCAP-48/1200	92	78045	RV3000-2SAC	89	78336	PV1800-SAC-S/S	82	78379	SACPL2-60/1500-S/S	93
77926	RCAP-54/1350	92	78080	P-CARK-V24/600	83	78337	PV1500-2SAC-S/S	82	78379	SACPL2-60/1500-S/S	100
77927	RCAP-60/1500	92	78081	P-CARK-V30/750	83	78338	PV1800-2SAC-S/S	82	78379	SACPL2-60/1500-S/S	106
77928	RCAP-72/1800	92	78082	P-CARK-V36/900	83	78339	PV2100-2SAC-S/S	82	78380	SACPL2-72/1800-S/S	86
77937	MHS-CARK-V24/600	97	78083	P-CARK-V42/1050	83	78340	PV2400-2SAC-S/S	82	78380	SACPL2-72/1800-S/S	93
77937	MHS-CARK-V24/600	104	78084	P-CARK-V48/1200	83	78341	PV3000-2SAC-S/S	82	78380	SACPL2-72/1800-S/S	100
77938	MHS-CARK-V30/750	97	78085	P-CARK-V54/1350	83	78342	RV600-SAC-S/S	89	78380	SACPL2-72/1800-S/S	106
77938	MHS-CARK-V30/750	104	78086	P-CARK-V60/1500	83	78343	RV750-SAC-S/S	89	78381	SACPL2-84/2100-S/S	86
77939	MHS-CARK-V36/900	97	78087	P-CARK-V72/1800	83	78344	RV900-SAC-S/S	89	78381	SACPL2-84/2100-S/S	93
77939	MHS-CARK-V36/900	104	78093	P-CARK2-V60/1500	83	78345	RV1050-SAC-S/S	89	78381	SACPL2-84/2100-S/S	100
77940	MHS-CARK-V42/1050	97	78094	P-CARK2-V72/1800	83	78346	RV1200-SAC-S/S	89	78381	SACPL2-84/2100-S/S	106
77940	MHS-CARK-V42/1050	104	78095	P-CARK2-V84/2100	83	78347	RV1350-SAC-S/S	89	78382	SACPL2-96/2400-S/S	86
77941	MHS-CARK-V48/1200	97	78096	P-CARK2-V96/2400	83	78348	RV1500-SAC-S/S	89	78382	SACPL2-96/2400-S/S	93
77941	MHS-CARK-V48/1200	104	78097	P-CARK2-V120/3000	83	78349	RV1800-SAC-S/S	89	78382	SACPL2-96/2400-S/S	100

INDEX By Item Code

Item Code	Ordering Number	Page #	Item Code	Ordering Number	Page #	Item Code	Ordering Number	Page #	Item Code	Ordering Number	Page #
78382	SACPL2-96/2400-S/S	106	78511	EZPTSK	21	78580	CART-48/1200-S/S	86	78587	CART2-96/2400-S/S	55
78383	SACPL2-120/3000-S/S	86	78512	EZPTSKHD	21	78580	CART-48/1200-S/S	91	78587	CART2-96/2400-S/S	84
78383	SACPL2-120/3000-S/S	93	78513	CST1HDM-W	99	78580	CART-48/1200-S/S	93	78587	CART2-96/2400-S/S	86
78383	SACPL2-120/3000-S/S	100	78514	CST1HDM-S	99	78580	CART-48/1200-S/S	98	78587	CART2-96/2400-S/S	91
78383	SACPL2-120/3000-S/S	106	78515	CST1HDM-B	99	78580	CART-48/1200-S/S	100	78587	CART2-96/2400-S/S	93
78384	CSTHDMK-S/S	101	78516	CST1HDM-G	99	78580	CART-48/1200-S/S	105	78587	CART2-96/2400-S/S	98
78385	CTS-W-S/S	101	78517	SST1HDM-W	78	78580	CART-48/1200-S/S	106	78587	CART2-96/2400-S/S	100
78386	CTS-S-S/S	101	78517	SST1HDM-W	99	78580	CART2-48/1200-S/S	48	78587	CART2-96/2400-S/S	105
78387	CTS-B-S/S	13	78517	SST1HDM-W	117	78580	CART2-48/1200-S/S	54	78587	CART2-96/2400-S/S	107
78387	CTS-B-S/S	101	78518	SST1HDM-S	78	78581	CART-54/1350-S/S	84	78588	CART2-120/3000-S/S	49
78388	CTS-G-S/S	101	78518	SST1HDM-S	99	78581	CART-54/1350-S/S	86	78588	CART2-120/3000-S/S	55
78389	CSTHDPM-S/S	101	78518	SST1HDM-S	117	78581	CART-54/1350-S/S	91	78588	CART2-120/3000-S/S	84
78390	CST1HDM-W-S/S	101	78518	SST1HDM-S	118	78581	CART-54/1350-S/S	93	78588	CART2-120/3000-S/S	86
78391	CST1HDM-S-S/S	101	78519	SST1HDM-B	78	78581	CART-54/1350-S/S	98	78588	CART2-120/3000-S/S	91
78392	CST1HDM-B-S/S	101	78519	SST1HDM-B	99	78581	CART-54/1350-S/S	100	78588	CART2-120/3000-S/S	93
78393	CST1HDM-G-S/S	101	78519	SST1HDM-B	117	78581	CART-54/1350-S/S	105	78588	CART2-120/3000-S/S	98
78394	SST1HDM-W-S/S	78	78537	MHS-600V-SAC-S/S	96	78581	CART-54/1350-S/S	106	78588	CART2-120/3000-S/S	100
78394	SST1HDM-W-S/S	101	78538	MHS-750V-SAC-S/S	96	78582	CART-60/1500-S/S	48	78588	CART2-120/3000-S/S	105
78394	SST1HDM-W-S/S	117	78539	MHS-900V-SAC-S/S	96	78582	CART-60/1500-S/S	54	78588	CART2-120/3000-S/S	107
78395	SST1HDM-S-S/S	78	78540	MHS-1050V-SAC-S/S	96	78582	CART-60/1500-S/S	84	78634	CART2-66/1650-S/S	49
78395	SST1HDM-S-S/S	101	78541	MHS-1200V-SAC-S/S	96	78582	CART-60/1500-S/S	86	78634	CART2-66/1650-S/S	55
78395	SST1HDM-S-S/S	117	78542	MHS-1350V-SAC-S/S	96	78582	CART-60/1500-S/S	91	78635	CART2-78/1950-S/S	49
78396	SST1HDM-B-S/S	78	78543	MHS-1500V-SAC-S/S	96	78582	CART-60/1500-S/S	93	78635	CART2-78/1950-S/S	55
78396	SST1HDM-B-S/S	101	78544	MHS-1800V-SAC-S/S	96	78582	CART-60/1500-S/S	98	78635	CART2-78/1950-S/S	84
78396	SST1HDM-B-S/S	117	78545	MHS-1500V-2SAC-S/S	96	78582	CART-60/1500-S/S	100	78635	CART2-78/1950-S/S	86
78397	SACRH-S/S	87	78546	MHS-1800V-2SAC-S/S	96	78582	CART-60/1500-S/S	105	78635	CART2-78/1950-S/S	91
78397	SACRH-S/S	94	78547	MHS-2100V-2SAC-S/S	96	78582	CART-60/1500-S/S	106	78635	CART2-78/1950-S/S	93
78397	SACRH-S/S	101	78548	MHS-2400V-2SAC-S/S	96	78583	CART-72/1800-S/S	48	78635	CART2-78/1950-S/S	98
78397	SACRH-S/S	107	78549	MHS-3000V-2SAC-S/S	96	78583	CART-72/1800-S/S	54	78635	CART2-78/1950-S/S	100
78398	SACRHL-S/S	87	78576	CART-24/600-S/S	48	78583	CART-72/1800-S/S	84	78635	CART2-78/1950-S/S	105
78398	SACRHL-S/S	94	78576	CART-24/600-S/S	54	78583	CART-72/1800-S/S	86	78635	CART2-78/1950-S/S	107
78398	SACRHL-S/S	101	78576	CART-24/600-S/S	84	78583	CART-72/1800-S/S	91	78639	CART2-114/2850-S/S	49
78398	SACRHL-S/S	107	78576	CART-24/600-S/S	86	78583	CART-72/1800-S/S	93	78639	CART2-114/2850-S/S	55
78399	SACKRP-S/S	87	78576	CART-24/600-S/S	91	78583	CART-72/1800-S/S	98	78640	CART2-126/3150-S/S	49
78399	SACKRP-S/S	94	78576	CART-24/600-S/S	93	78583	CART-72/1800-S/S	100	78640	CART2-126/3150-S/S	55
78399	SACKRP-S/S	101	78576	CART-24/600-S/S	98	78583	CART-72/1800-S/S	105	78642	SACPL2-78/1950-S/S	86
78399	SACKRP-S/S	107	78576	CART-24/600-S/S	100	78583	CART-72/1800-S/S	106	78642	SACPL2-78/1950-S/S	93
78401	SACRKT-S/S	87	78576	CART-24/600-S/S	105	78584	CART-60/1500-S/S	49	78642	SACPL2-78/1950-S/S	100
78401	SACRKT-S/S	94	78576	CART-24/600-S/S	106	78584	CART2-60/1500-S/S	55	78642	SACPL2-78/1950-S/S	106
78401	SACRKT-S/S	101	78577	CART-30/750-S/S	84	78584	CART2-60/1500-S/S	84	78649	MHS-1950V-2SAC-S/S	96
78401	SACRKT-S/S	107	78577	CART-30/750-S/S	86	78584	CART2-60/1500-S/S	86	78656	PV1950-2SAC-S/S	82
78456	SSFRB	32	78577	CART-30/750-S/S	91	78584	CART2-60/1500-S/S	91	78663	RV1950-2SAC-S/S	89
78456	SSFRB	35	78577	CART-30/750-S/S	93	78584	CART2-60/1500-S/S	93	78683	PACB60	74
78462	LSTMPK2-S/S	13	78577	CART-30/750-S/S	98	78584	CART2-60/1500-S/S	98	78683	PACB60	79
78472	CRB-W16	19	78577	CART-30/750-S/S	100	78584	CART2-60/1500-S/S	100	78683	PACB60	99
78473	CRB-W22	19	78577	CART-30/750-S/S	105	78584	CART2-60/1500-S/S	105	78684	PAT1	29
78474	CRB-W28	19	78577	CART-30/750-S/S	106	78584	CART2-60/1500-S/S	107	78685	PAT2	29
78475	CRB-W34	19	78578	CART-36/900-S/S	48	78585	CART2-72/1800-S/S	49	78789	SB4	137
78476	CRB-W40	19	78578	CART-36/900-S/S	54	78585	CART2-72/1800-S/S	55	78789	SB4	139
78477	CRB-W46	19	78578	CART-36/900-S/S	84	78585	CART2-72/1800-S/S	84	78789	SB4	141
78478	CRB-W52	19	78578	CART-36/900-S/S	86	78585	CART2-72/1800-S/S	86	78789	SB4	143
78479	CRB-W58	19	78578	CART-36/900-S/S	91	78585	CART2-72/1800-S/S	91	78790	SB5	137
78480	CRB-W64	19	78578	CART-36/900-S/S	93	78585	CART2-72/1800-S/S	93	78790	SB5	139
78481	CRB-W70	19	78578	CART-36/900-S/S	98	78585	CART2-72/1800-S/S	98	78790	SB5	141
78488	EZP1T-212	20	78578	CART-36/900-S/S	100	78585	CART2-72/1800-S/S	100	78790	SB5	143
78489	EZP1T-218	20	78578	CART-36/900-S/S	105	78585	CART2-72/1800-S/S	105	78791	PATLK	29
78490	EZP1T-224	20	78578	CART-36/900-S/S	106	78585	CART2-72/1800-S/S	107	78794	PATHK	29
78491	EZP1T-230	20	78579	CART-42/1050-S/S	48	78586	CART2-84/2100-S/S	49	78808	EST-P-S/S	18
78492	EZP1T-236	20	78579	CART-42/1050-S/S	54	78586	CART2-84/2100-S/S	55	78809	EST-W-S/S	18
78493	EZP1T-242	20	78579	CART-42/1050-S/S	84	78586	CART2-84/2100-S/S	84	78810	EST-G-S/S	18
78494	EZP1T-248	20	78579	CART-42/1050-S/S	86	78586	CART2-84/2100-S/S	86	78812	EZP1P12-S/S	18
78495	EZP1T-254	20	78579	CART-42/1050-S/S	91	78586	CART2-84/2100-S/S	91	78838	CFG-212	15
78496	EZP1T-260	20	78579	CART-42/1050-S/S	93	78586	CART2-84/2100-S/S	93	78839	CFG-218	15
78497	EZP1T-272	20	78579	CART-42/1050-S/S	98	78586	CART2-84/2100-S/S	98	78840	CFG-224	15
78507	EZPTMPK	21	78579	CART-42/1050-S/S	100	78586	CART2-84/2100-S/S	100	78841	CFG-230	15
78508	EZPTCK	21	78579	CART-42/1050-S/S	105	78586	CART2-84/2100-S/S	105	78842	CFG-236	15
78509	EZPTCKHD	21	78579	CART-42/1050-S/S	106	78586	CART2-84/2100-S/S	107	78843	CFG-242	15
78510	EZPTSR	21	78580	CART-48/1200-S/S	84	78587	CART2-96/2400-S/S	49	78844	CFG-248	15

INDEX By Item Code

Item Code	Ordering Number	Page #	Item Code	Ordering Number	Page #	Item Code	Ordering Number	Page #	Item Code	Ordering Number	Page #
78845	CFG-254	15	79206	USPB	113	79511	MBDS-60	122	79810	YTAHD-72/1800	63
78846	CFG-260	15	79206	USPB2	112	79512	MBDS-72	122	79811	YCART-18/450-TC	59
78847	CFG-272	15	79206	USPB2	113	79513	MBDS-84	122	79812	YCART-24/600-TC	59
78848	EZP1PL-S/S	18	79207	UHPB2	112	79514	MBRD-18	120	79813	YCART-30/750-TC	59
78849	ESTAK-EST-S/S	18	79207	UHPB2	113	79514	MBRD-18	122	79814	YCART-36/900-TC	59
78849	ESTAK-EST-S/S	43	79224	CCKL	66	79515	MBRD-24	120	79815	YCART-42/1050-TC	59
78849	ESTAK-SS	113	79224	CCKL	68	79515	MBRD-24	122	79816	YCART-48/1200-TC	59
78850	LS-SW-S/S	13	79225	CCKHDL	66	79516	MBRD-30	120	79817	YCART-36/900-HDP	59
78919	CCMK	66	79225	CCKHDL	68	79516	MBRD-30	122	79818	YCART-42/1050-HDP	59
78919	CCMK	68	79225	CCKHDL	76	79517	MBRD-36	120	79819	YCART-48/1200-HDP	59
78920	CCMKHD	63	79226	CCKL-S/S	66	79517	MBRD-36	122	79820	YCART-54/1350-HDP	59
78920	CCMKHD	66	79226	CCKL-S/S	68	79518	MBRD-42	120	79821	YCART-60/1500-HDP	59
78920	CCMKHD	68	79227	CCKHDL-S/S	66	79518	MBRD-42	122	79822	YCART-72/1800-HDP	59
78920	CCMKHD	76	79227	CCKHDL-S/S	68	79519	MBRD-48	120	79829	YCART-36/900-HDTC	59
78921	CCMK-S/S	66	79227	CCKHDL-S/S	76	79519	MBRD-48	122	79830	YCART-42/1050-HDTC	59
78921	CCMK-S/S	68	79228	CCKR	66	79520	MBRD-54	120	79831	YCART-48/1200-HDTC	59
78922	CCMKHD-S/S	66	79228	CCKR	68	79520	MBRD-54	122	79832	YCART-54/1350-HDTC	59
78922	CCMKHD-S/S	68	79228	CCKR	68	79521	MBRD-60	120	79833	YCART-60/1500-HDTC	59
78922	CCMKHD-S/S	76	79229	CCKHDR	68	79521	MBRD-60	122	79834	YCART-72/1800-HDTC	59
78923	EZP1MPK-S/S	18	79229	CCKHDR	76	79522	MBRD-72	120	79835	YTACHD	63
78933	LSTMPK-S/S	13	79230	CCKR-S/S	66	79522	MBRD-72	122	79836	YST-Y	62
79009	HDRBK	131	79230	CCKR-S/S	68	79523	MBRD-84	120	79837	YST-P	62
79010	HDR24	131	79231	CCKHDR-S/S	66	79523	MBRD-84	122	79838	YST-S	62
79011	HDR30	131	79231	CCKHDR-S/S	68	79524	MBCMK	122	79839	YSTDH-GR	63
79012	HDR36	131	79231	CCKHDR-S/S	76	79525	MBCBC	122	79840	YSTDH-S	63
79013	HDR42	131	79232	CCKTS	66	79526	MBCB	122	79841	YSTDH-BL	63
79014	HDR48	131	79232	CCKTS	68	79527	MBADB	122	79842	YSTDH-BK	63
79015	HDR54	131	79233	CCKHDTs	66	79528	MBCBM	122	79843	YSTMB	62
79016	HDR60	131	79233	CCKHDTs	68	79529	MBCM-1	122	79844	YSTDBK	62
79017	HDRS72	131	79233	CCKHDTs	76	79530	MBCM-2	122	79845	YSTGBK	62
79018	HDRS84	131	79234	CCKTS-S/S	66	79531	MBCTA	122	79846	YSTLBK	62
79019	HDRR24	131	79234	CCKTS-S/S	68	79532	MBCBL	122	79847	YSTTBK-W	62
79020	HDRR30	131	79236	HDRGEK	131	79533	MBCMKK	122	79848	YSTPMK	62
79021	HDRR36	131	79288	ESS-S-S/S	113	79534	MBCEC	122	79849	YSTDHMB	63
79022	HDRR42	131	79289	PFC-P-S/S	66	79535	STLP	122	79850	YSTDHDBK	63
79023	HDRR48	131	79378	MSR2-S/S	168	79536	MBCDBK	120	79851	YSTDHGBK	63
79024	HDRR54	131	79431	MSTHD-W	71	79536	MBCDBK	122	79852	YSTDHLBK	63
79025	HDRR60	131	79431	MSTHD-W	73	79573	YT-P	59	79853	YSTDHDK-W	63
79026	HDRRS72	131	79431	MSTHD-W	117	79574	YT-C	59	79854	YSTPHDMK	63
79027	HDRRS84	131	79432	MSTHD-S	71	79617	YCART-18/450-P	59	79855	YSTTBK-B	62
79056	PSTS-S-S/S	43	79432	MSTHD-S	73	79618	YCART-24/600-P	59	79856	YSTDHDK-B	63
79057	STS-G-S/S	43	79432	MSTHD-S	117	79619	YCART-30/750-P	59	79857	YSTANK	62
79057	STS-G-S/S	43	79433	MSTHD-B	71	79620	YCART-36/900-P	59	79858	YSTANK	63
79057	STS-G-S/S	71	79433	MSTHD-B	73	79621	YCART-42/1050-P	59	81045	C-PSTA	112
79057	STS-G-S/S	73	79433	MSTHD-B	117	79622	YCART-48/1200-P	59	81250	RIBBK	137
79057	STS-G-S/S	117	79434	MSTDB	74	79623	YTAC	62	81250	RIBBK	139
79060	DWVP96	117	79435	MSTAM	71	79647	FMS-600V	69	81250	RIBBK	141
79062	CDWB96	118	79435	MSTAM	73	79648	FMS-750V	69	81250	RIBBK	143
79063	MDWS-96	116	79435	MSTAM	117	79649	FMS-900V	69	81896	MESPKR	112
79069	SST1HDM-G	78	79436	MST-MBL	74	79650	FMS-1050V	69	82174	QMTBK-GCN	112
79069	SST1HDM-G	99	79437	MST-MBR	74	79651	FMS-1200V	69	82174	QMTBK-GCN	113
79069	SST1HDM-G	117	79494	MBC-18	120	79652	FMS-1350V	69	82175	QMTBK-WS-MT	112
79070	SSTHK	78	79495	MBC-24	120	79653	FMS-1500V	69	82175	QMTBK-WS-MT	113
79070	SSTHK	117	79496	MBC-30	120	79654	FMS-1800V	69	82182	QMTPSBK-CN	112
79071	SSTHK-S/S	78	79497	MBC-36	120	79656	PACB100	74	82185	EZSB600-1200C	136
79071	SSTHK-S/S	117	79498	MBC-42	120	79656	PACB100	79	82186	EZSB750-1200C	136
79072	HDRBK-HD	131	79499	MBC-48	120	79656	PACB100	99	82187	EZSB900-1200C	136
79200	SPFC	73	79500	MBC-54	120	79677	YT-HDP	59	82188	EZSB1050-1200C	136
79200	SPFC	76	79501	MBC-60	120	79728	YT-HDC	59	82189	EZSB1200-1200C	136
79200	SPFC	78	79502	MBC-72	120	79795	YSTS-Y	62	82190	EZSB1350-1200C	136
79200	SPFC	98	79503	MBC-84	120	79796	YSTS-P	62	82191	EZSB1500-1200C	136
79200	SPFC	105	79504	MBDS-18	122	79797	YSTDHDS-GR	63	82192	EZSB1800-1200C	136
79201	SPFC-S/S	73	79505	MBDS-24	122	79798	YSTDHDS-BL	63	82193	EZSB600-1500C	136
79201	SPFC-S/S	76	79506	MBDS-30	122	79805	YTAHD-36/900	63	82194	EZSB750-1500C	136
79201	SPFC-S/S	78	79507	MBDS-36	122	79806	YTAHD-42/1050	63	82195	EZSB900-1500C	136
79201	SPFC-S/S	101	79508	MBDS-42	122	79807	YTAHD-48/1200	63	82196	EZSB1050-1500C	136
79201	SPFC-S/S	107	79509	MBDS-48	122	79808	YTAHD-54/1350	63	82197	EZSB1200-1500C	136
79206	USPB	112	79510	MBDS-54	122	79809	YTAHD-60/1500	63	82198	EZSB1350-1500C	136

INDEX By Item Code

Item Code	Ordering Number	Page #	Item Code	Ordering Number	Page #	Item Code	Ordering Number	Page #	Item Code	Ordering Number	Page #
82199	EZSB1500-1500C	136	82343	PTPK-MT	112	82362	EZBS-1500	141	82823	P-CARK2-V60/1500-S/S	
82200	EZSB1800-1500C	136	82344	EZRMMK	137	82364	MESBK-PS	112		PV2ECKSS	83
82201	EZSB600-1200I	138	82344	EZRMMK	139	82364	MESBK-PS	113	82824	P-CARK2-V72/1800-S/S	
82202	EZSB750-1200I	138	82345	EZWPK-600	137	82393	SHIM-LDKIT	137		PV2ECKSS	83
82203	EZSB900-1200I	138	82345	EZWPK-600	139	82393	SHIM-LDKIT	139	82825	P-CARK2-V84/2100-S/S	
82204	EZSB1050-1200I	138	82345	EZWPK-600	141	82393	SHIM-LDKIT	141		PV2ECKSS	83
82205	EZSB1200-1200I	138	82345	EZWPK-600	143	82394	SHIM-MDKIT	143	82826	P-CARK2-V96/2400-S/S	
82206	EZSB1350-1200I	138	82346	EZWPK-750	137	82397	IBS-M1200	143		PV2ECKSS	83
82207	EZSB1500-1200I	138	82346	EZWPK-750	139	82398	IBS-M1500	143	82827	P-CARK2-V120/3000-S/S	
82208	EZSB1800-1200I	138	82346	EZWPK-750	141	82410	EZAI-600	136		PV2ECKSS	83
82209	EZSB600-1500I	138	82346	EZWPK-750	143	82411	EZAI-750	136	82828	R-CARK-V24/600-S/S	
82210	EZSB750-1500I	138	82347	EZWPK-900	137	82412	EZAI-900	136		RVECKSS	90
82211	EZSB900-1500I	138	82347	EZWPK-900	139	82413	EZAI-1050	136	82829	R-CARK-V30/750-S/S	
82212	EZSB1050-1500I	138	82347	EZWPK-900	141	82414	EZAI-1200	136		RVECKSS	90
82213	EZSB1200-1500I	138	82347	EZWPK-900	143	82415	EZAI-1350	136	82830	R-CARK-V36/900-S/S	
82214	EZSB1350-1500I	138	82348	EZWPK-1050	137	82416	EZAI-1500	136		RVECKSS	90
82215	EZSB1500-1500I	138	82348	EZWPK-1050	139	82417	EZAI-1800	136	82831	R-CARK-V42/1050-S/S	
82216	EZSB1800-1500I	138	82348	EZWPK-1050	141	82689	USP18/450	112		RVECKSS	90
82217	EZIB600-1200L	140	82348	EZWPK-1050	143	82690	USP24/600	112	82832	R-CARK-V48/1200-S/S	
82218	EZIB750-1200L	140	82349	EZWPK-1200	137	82691	USP30/750	112		RVECKSS	90
82219	EZIB900-1200L	140	82349	EZWPK-1200	139	82692	USP36/900	112	82833	R-CARK-V54/1350-S/S	
82220	EZIB1050-1200L	140	82349	EZWPK-1200	141	82693	USP42/1050	112		RVECKSS	90
82221	EZIB1200-1200L	140	82349	EZWPK-1200	143	82694	USP48/1200	112	82834	R-CARK-V60/1500-S/S	
82222	EZIB1350-1200L	140	82350	EZWPK-1350	137	82695	USP54/1350	112		RVECKSS	90
82223	EZIB1500-1200L	140	82350	EZWPK-1350	141	82696	USP56/1400	112	82835	R-CARK-V72/1800-S/S	
82224	EZIB1800-1200L	140	82350	EZWPK-1350	143	82697	USP60/1500	112		RVECKSS	90
82225	EZIB600-1500L	140	82350	EZWPK-13500	139	82698	USP64/1600	112	82836	R-CARK2-V60/1500-S/S	
82226	EZIB750-1500L	140	82351	EZWPK-1500	137	82699	USP72/1800	112		RV2ECKSS	90
82227	EZIB900-1500L	140	82351	EZWPK-1500	139	82700	USP80/2000	112	82837	R-CARK2-V72/1800-S/S	
82228	EZIB1050-1500L	140	82351	EZWPK-1500	141	82701	USP84/2100	112		RV2ECKSS	90
82229	EZIB1200-1500L	140	82351	EZWPK-1500	143	82702	USP88/2200	112	82838	R-CARK2-V84/2100-S/S	
82230	EZIB1350-1500L	140	82352	EZWPK-1800	137	82703	USP94/2400	112		RV2ECKSS	90
82231	EZIB1500-1500L	140	82352	EZWPK-1800	139	82704	USP98/2500	112	82839	R-CARK2-V96/2400-S/S	
82232	EZIB1800-1500L	140	82352	EZWPK-1800	141	82707	UTV450-S/S	110		RV2ECKSS	90
82233	EZIB600-1200M	142	82352	EZWPK-1800	143	82708	UTV600-S/S	110	82841	MHS-CARK-V24/600-S/S	
82234	EZIB750-1200M	142	82353	EZCSK-600	137	82709	UTV750-S/S	110		MVECKSS	104
82235	EZIB900-1200M	142	82353	EZCSK-600	139	82710	UTV900-S/S	110	82842	MHS-CARK-V30/750-S/S	
82236	EZIB1050-1200M	142	82353	EZCSK-600	141	82711	UTV1050-S/S	110		MVECKSS	97
82237	EZIB1200-1200M	142	82353	EZCSK-600	143	82712	UTV1200-S/S	110	82842	MHS-CARK-V30/750-S/S	
82238	EZIB1350-1200M	142	82354	EZCSK-750	137	82713	UTV1350-S/S	110		MVECKSS	104
82239	EZIB1500-1200M	142	82354	EZCSK-750	139	82714	UTV1400-S/S	110	82843	MHS-CARK-V36/900-S/S	
82240	EZIB1800-1200M	142	82354	EZCSK-750	141	82715	UTV1500-S/S	110		MVECKSS	97
82241	EZIB600-1500M	142	82354	EZCSK-750	143	82716	UTV1600-S/S	110	82843	MHS-CARK-V36/900-S/S	
82242	EZIB750-1500M	142	82355	EZCSK-900	137	82717	UTV1800-S/S	110		MVECKSS	104
82243	EZIB900-1500M	142	82355	EZCSK-900	139	82718	UTV2000-S/S	110	82844	MHS-CARK-V42/1050-S/S	
82244	EZIB1050-1500M	142	82355	EZCSK-900	141	82719	UTV2100-S/S	110		MVECKSS	97
82245	EZIB1200-1500M	142	82355	EZCSK-900	143	82720	UTV2200-S/S	110	82844	MHS-CARK-V42/1050-S/S	
82246	EZIB1350-1500M	142	82356	EZCSK-1050	137	82721	UTV2400-S/S	110		MVECKSS	104
82247	EZIB1500-1500M	142	82356	EZCSK-1050	139	82722	UTV2500-S/S	110	82845	MHS-CARK-V48/1200-S/S	
82248	EZIB1800-1500M	142	82356	EZCSK-1050	141	82810	SCU60-S/S	113		MVECKSS	104
82281	EZBMK-600	141	82356	EZCSK-1050	143	82811	SCUHD-S/S	113	82845	MHS-CARK-V48/1200-S/S	
82281	EZBMK-600	143	82357	EZCSK-1200	137	82812	SCU60	112		MVECKSS	97
82282	EZBMK-750	141	82357	EZCSK-1200	139	82813	SCUHD	112	82846	MHS-CARK-V54/1350-S/S	
82282	EZBMK-750	143	82357	EZCSK-1200	141	82815	P-CARK-V24/600-S/S			MVECKSS	104
82283	EZBMK-900	143	82357	EZCSK-1200	143		PVECKSS	83	82847	MHS-CARK-V60/1500-S/S	
82283	EZBMK-9000	141	82358	EZCSK-1350	137	82816	P-CARK-V30/750-S/S			MVECKSS	97
82284	EZBMK-1050	141	82358	EZCSK-1350	139		PVECKSS	83	82847	MHS-CARK-V60/1500-S/S	
82284	EZBMK-1050	143	82358	EZCSK-1350	141	82817	P-CARK-V36/900-S/S			MVECKSS	104
82285	EZBMK-1200	141	82358	EZCSK-1350	143		PVECKSS	83	82848	MHS-CARK-V72/1800-S/S	
82285	EZBMK-1200	143	82359	EZCSK-1500	137	82818	P-CARK-V42/1050-S/S			MVECKSS	97
82286	EZBMK-1350	141	82359	EZCSK-1500	139		PVECKSS	83	82848	MHS-CARK-V72/1800-S/S	
82286	EZBMK-1350	143	82359	EZCSK-1500	141	82819	P-CARK-V48/1200-S/S			MVECKSS	104
82287	EZBMK-1500	141	82359	EZCSK-1500	143		PVECKSS	83	82849	MHS-CARK2-V60/1500-S/S	
82287	EZBMK-1500	143	82360	EZCSK-1800	137	82820	P-CARK-V54/1350-S/S			MV2CKSS	97
82288	EZBMK-1800	141	82360	EZCSK-1800	139		PVECKSS	83	82849	MHS-CARK2-V60/1500-S/S	
82288	EZBMK-1800	143	82360	EZCSK-1800	141	82821	P-CARK-V60/1500-S/S			MV2CKSS	104
82289	MPSTA-S/S	113	82360	EZCSK-1800	143		PVECKSS	83	82850	MHS-CARK2-V72/1800-S/S	
82342	PTPK-MT-S/S	113	82361	EZBS-1200	141	82822	P-CARK-V72/1800-S/S			MV2CKSS	97

INDEX By Item Code

Item Code	Ordering Number	Page #	Item Code	Ordering Number	Page #	Item Code	Ordering Number	Page #	Item Code	Ordering Number	Page #
82850	MHS-CARK2-V72/1800-S/S MV2CKSS	104	83140	YTHD-TC-1800S	57	90636	CRDF48	123	91401	SKPU-DUAL-6X3/4X25	171
82851	MHS-CARK2-V84/2100-S/S MV2CKSS	97	83223	YTC-450	56	90637	CRDF54	123	91402	SKPU-DUAL-8X1/2X25	171
82851	MHS-CARK2-V84/2100-S/S MV2CKSS	104	83224	YTC-600	56	90638	CRDF50	123	91403	SKPU-DUAL-8X3/4X25	171
82852	MHS-CARK2-V96/2400-S/S MV2CKSS	97	83225	YTC-750	56	90641	CBC3R	123	91404	SKPU-DUAL-6X1/2X50	171
82852	MHS-CARK2-V96/2400-S/S MV2CKSS	104	83226	YTC-900	56	90795	PTEZHD-1500	160	91405	SKPU-DUAL-6X3/4X50	171
82852	MHS-CARK2-V96/2400-S/S MV2CKSS	104	83227	YTC-1050	56	90796	PTEZHD-1600	160	91406	SKPU-DUAL-8X1/2X50	171
82853	MHS-CARK2-V120/3000-S/S MV2CKS	97	83228	YTC-1200	56	90797	PTEZHD-2000	160	91407	SKPU-DUAL-8X3/4X50	171
82853	MHS-CARK2-V120/3000-S/S MV2CKS	104	83229	YT-450S	56	90803	PTEZHD-MBK	160	91444	FMSC2	71
82876	P-CARK2-V78/1950-S/S PV2ECKSS	83	83230	YT-600S	56	90804	PTEZHD-PBK	160	91444	FMSC2	71
82887	UHSPK-M	112	83231	YT-750S	56	90805	PTEZHD-DCK	160	A1854	CBD-M-S/S	156
82888	USPK-SS-M	113	83232	YT-900S	56	90806	PTEZHD-WRBK	160	A1856	CBD-L-S/S	156
82889	UHSPK-SS-M	113	83233	YT-1050S	56	90807	PTEZHD-JBBK	160	A0012	WCB	128
82890	UMBK-M	112	83234	YT-1200S	56	91222	SKPU-6X1/2X50	172	A0012	WCB	129
82891	UMBK-SS-M	113	83241	YT-TC-450S	56	91223	SKPU-6X3/4X50	172	A0151	HBP2600-PL-TP	155
82892	MESPBL-SS	113	83242	YT-TC-600S	56	91224	SKPU-8X1X50	172	A0223	HBP750-B	151
82893	MUPSBK-SS	113	83243	YT-TC-750S	56	91225	SKPU-8X3/4X50	172	A0224	HBP900-B	151
82894	MESPKR-SS	113	83244	YT-TC-900S	56	91234	SKPU-12X1X35	172	A0235	PTMSR	167
82895	MQMTSBK-SS	113	83245	YT-TC-1050S	56	91254	CRB-UHT-400	19	A0316	SB1200A	128
82896	MUPSBK	112	83246	YT-TC-1200S	56	91255	CRB-UHT-550	19	A0407	SB750A	128
82897	UST-P-MT	112	87895	MESPBL	112	91256	CRB-UHT-700	19	A0435	SB1050A	128
82898	UST-S-MT	112	90181	MSTHD-SS-W	73	91257	CRB-UHT-850	19	A0612	BP800-1050MF-S/S MAIN FRAME	151
82899	UST-W-MT	112	90181	MSTHD-W-S/S	71	91258	CRB-UHT-1000	19	A0613	BP800-1050-PL-S/S	151
82900	UST-G-MT	112	90181	MSTHD-W-S/S	117	91259	CRB-UHT-1150	19	A0614	BP-LA-S/S	151
82901	UST-P-MT-SS	113	90182	MSTHD-S-S/S	64	91260	CRB-UHT-1300	19	A0615	BP-MB-S/S	151
82902	UST-S-MT-SS	113	90182	MSTHD-S-S/S	71	91261	CRB-UHT-1450	19	A0616	BP-SC-S/S	151
82903	UST-W-MT-SS	113	90182	MSTHD-SS-S	73	91263	CRB-UHT-1750	19	A0617	BP-TL-S/S	151
82904	UST-G-MT-SS	113	90182	MSTHD-S-S-S	117	91263	CRB-UHT-1750	19	A0620	BP1200-1400MF-S/S MAIN FRAME	151
82932	YTP-18/450	62	90182	MSTHD-SS-S	73	91288	SKPU-4X1/2X25	172	A0621	BP1200-1400-PL-S/S	151
82933	YTP-24/600	62	90183	MSTHD-B-S/S	64	91289	SKPU-4X1/2X25	172	A0646	BP1500-1600MF-S/S MAIN FRAME	151
82934	YTP-30/750	62	90183	MSTHD-B-S/S	71	91290	SKPU-4X5/8X25	172	A0647	BP1500-1600-PL-S/S	151
82935	YTP-36/900	62	90183	MSTHD-B-S/S	117	91291	SKPU-4X3/4X25	172	A0682	BP450-750MF-S/S MAIN FRAME	151
82936	YTP-42/1050	62	90183	MSTHD-SS-B	73	91292	SKPU-4X1X25	172	A0683	BP450-750-PL-S/S	151
82937	YTP-48/1200	62	90184	MSTHD-G-S/S	64	91293	SKPU-4X3/8X50	172	A0887	SB600A	128
82949	YTA-18/450	62	90184	MSTHD-G-S/S	71	91294	SKPU-4X1/2X50	172	A0912	SB900A	128
82950	YTA-24/600	62	90184	MSTHD-G-S/S	117	91295	SKPU-4X5/8X50	172	A1155	HBP-MB-TP-S/S	153
82951	YTA-30/750	62	90184	MSTHD-SS-G	73	91296	SKPU-4X3/4X50	172	A1155	HBP-MB-TP-S/S	155
82952	YTA-36/900	62	90264	ESBK-ATEX	18	91297	SKPU-4X1X50	172	A1357	SB1800A	128
82953	YTA-42/1050	62	90265	PTEZ-450	160	91298	SKPU-6X3/8X25	172	A1436	FLSC2000-S/S	170
82954	YTA-48/1200	62	90266	PTEZ-600	160	91299	SKPU-6X5/8X25	172	A1437	FLSC-TP-S/S	170
83099	YTCHD-900	57	90267	PTEZ-750	160	91300	SKPU-6X1X25	172	A1438	FLSC-CP-S/S	170
83100	YTCHD-1050	57	90268	PTEZ-900	160	91301	SKPU-6X3/8X50	172	A1439	FLSC2000-CB-S/S	170
83101	YTCHD-1200	57	90269	PTEZ-1050	160	91302	SKPU-6X5/8X50	172	A1440	FLSC2000-MC-S/S	170
83102	YTCHD-1350	57	90270	PTEZ-1200	160	91303	SKPU-6X1X50	172	A1546	BP1800MF-S/S	151
83103	YTCHD-1500	57	90283	SKPU-6x1/2x25	172	91304	SKPU-8X3/8X35	172	A1547	BP1800-PL-S/S	151
83105	YTCHD-1800	57	90284	SKPU-6x3/4x25	172	91305	SKPU-8X5/8X35	172	A1575	RPHD1800-S/S	68
83106	YTPHD-36/900	63	90285	SKPU-6x1/2x25	172	91306	SKPU-8X1X25	172	A1588	HXFHD1800M-S/S	37
83107	YTPHD-42/1050	63	90286	SKPU-8x3/4x25	172	91307	SKPU-8X3/8X50	172	A1589	HXFHD1800L-S/S	37
83108	YTPHD-48/1200	63	90351	PTEZMB	160	91308	SKPU-8X5/8X50	172	A1590	HXFHD2100M-S/S	37
83109	YTPHD-54/1350	63	90352	PTEZPB	160	91309	SKPU-8X1X50	172	A1591	HXFHD2100L-S/S	37
83110	YTPHD-60/1500	63	90353	PTEZDC	160	91310	SKPU-10X3/8X25	172	A1592	HXFHD2400M-S/S	37
83112	YTPHD-72/1800	63	90537	CBCS18	123	91311	SKPU-10X1/2X25	172	A1593	HXFHD2400L-S/S	37
83120	YTHD-900S	57	90538	CBCS24	123	91312	SKPU-10X5/8X25	172	A1594	HVHD1800M-S/S	39
83121	YTHD-1050S	57	90539	CBCS30	123	91313	SKPU-10X3/4X25	172	A1595	HVHD1800L-S/S	39
83122	YTHD-1200S	57	90540	CBCS36	123	91314	SKPU-10X1X25	172	A1596	HVHD1800LL-S/S	39
83123	YTHD-1350S	57	90541	CBCS42	123	91315	SKPU-10X3/8X50	172	A1597	HVHD2100M-S/S	39
83124	YTHD-1500S	57	90542	CBCS48	123	91316	SKPU-10X1/2X50	172	A1598	HVHD2100L-S/S	39
83126	YTHD-1800S	57	90543	CBCS54	123	91317	SKPU-10X5/8X50	172	A1599	HVHD2100LL-S/S	39
83134	YTHD-TC-900S	57	90544	CBCS60	123	91318	SKPU-10X3/4X50	172	A1600	HVHD2400M-S/S	39
83135	YTHD-TC-1050S	57	90616	PTEZHD-1050	160	91319	SKPU-10X1X50	172	A1601	HVHD2400L-S/S	39
83136	YTHD-TC-1200S	57	90617	PTEZHD-1200	160	91320	SKPU-12X3/8X25	172	A1602	HVHD2400LL-S/S	39
83137	YTHD-TC-1350S	57	90618	PTEZHD-1350	160	91321	SKPU-12X1/2X25	172	A1603	PVHD1800-S/S	65
83138	YTHD-TC-1500S	57	90619	PTEZHD-1500	160	91322	SKPU-12X5/8X25	172	A1604	PVHD2100-S/S	65
			90620	PTEZHD-1800	160	91323	SKPU-12X3/4X25	172	A1605	PVHD2400-S/S	65
			90621	PTEZHD-2100	160	91325	SKPU-12X3/8X50	172	A1610	RVHD2400-S/S	67
			90631	CRDF18	123	91326	SKPU-12X1/2X50	172			
			90632	CRDF24	123	91327	SKPUT-12X5/8X50	172			
			90633	CRDF30	123	91328	SKPU-12X3/4/50	172			
			90634	CRDF36	123	91329	SKPU-12X1X50	172			
			90635	CRDF42	123	91400	SKPU-DUAL-6X1/2X25	171			

INDEX By Item Code

Item Code	Ordering Number	Page #	Item Code	Ordering Number	Page #	Item Code	Ordering Number	Page #	Item Code	Ordering Number	Page #
A1613	PPHD2100 -S/S	66	A2319	HBP1400-B-TP	153	A2596	FLSCM-CP-S/S	170	DC-1-15-42-35		175
A1620	SB1400A	128	A2320	HBP1500-B-TP	153	A2629	CBD-ST-TB-S/S	157	DC-1-15-48-35		175
A1622	RBPRET	159	A2321	HBP1600-B-TP	153	A2671	UNB73	42	DC-1-15-54-35		175
A1626	RVHD1800-S/S	67	A2322	HBP1800-B-TP	153	A2704	RMC2-AP-S/S	171	DC-1-15-60-35		175
A1628	RVHD2100-S/S	67	A2323	HBP2000-B-TP	153	A2803	PPHD2100	66	DC-1-15-66-35		175
A1629	RPHD2100-S/S	68	A2324	HBP2400-B-TP	153	A2825	CRDLBLK-RH-S/S	87	DC-1-15-72-35		175
A1775	PPHD2400 -S/S	66	A2325	HBP2200-B-TP	153	A2825	CRDLBLK-RH-S/S	94	DC-1-15-84-35		175
A1781	PPHD1800-S/S	66	A2326	HBP2500-B-TP	153	A2825	CRDLBLK-RH-S/S	107	DC-1-15-96-35		175
A1783	HPHD2000-S/S	42	A2330	HBP-LA-TP	153	A2826	CRDLBLK-LH-S/S	87	LA-24		175
A1784	CBD-ST-XL-FR-B	157	A2396	HVHD2600M	38	A2826	CRDLBLK-LH-S/S	94	LA-30		175
A1838	SB1500A	128	A2397	HVHD2600LL	38	A2826	CRDLBLK-LH-S/S	107	LA-36		175
A1996	BP2000MF	151	A2449	CBD-ST-PB	157	A2829	MR-1500PG	130	LA-42		175
A2046	PVHD2000-S/S	65	A2461	HVHD2600L	38	A2830	MR-1600PG	130	LA-48		175
A2063	HPHD1800-S/S	42	A2462	HVHD2600M-S/S	39	A2831	MR-1800PG	130	LA-54		175
A2120	PPHD2000 -S/S	66	A2463	HVHD2600L-S/S	39	A2832	MR-2100PG	130	LA-60		175
A2138	CBD-ST-XL-S/S	157	A2464	HVHD2600LL-S/S	39	A2833	MR-2400PG	130	LA-66		175
A2189	HBP-SC-TP-S/S	153	A2465	HVHD3000M-S/S	39	A2834	MR-2600PG	130	LA-72		175
A2189	HDSTCK-S/S	42	A2466	HVHD3000L-S/S	39	A2835	MR-3000PG	130	LA-84		175
A2215	CBD-ST-CS-S/S	157	A2467	HVHD3000LL-S/S	39	A2836	MR-450PG	130	LA-96		175
A2218	CBD-ST-L-FR-B	157	A2474	HBP-TP-900 S/S	152	A2837	MR-600PG	130	MAIN FRAME		151
A2237	HBP1050-B	151	A2475	HBP-TP-1050 S/S	152	A2838	MR-750PG	130	PTM-1050-1		167
A2283	HBP900-TP	152	A2476	HBP-TP-1200 S/S	152	A2839	MR-900PG	130	PTM-1050-1-S/S		168
A2284	HBP1050-TP	152	A2477	HBP-TP-1400 S/S	152	A2840	MR-1050PG	130	PTM-1050-2		167
A2285	HBP1200-TP	152	A2478	HBP-TP-1500 S/S	152	A2841	MR-1200PG	130	PTM-1050-2-S/S		168
A2286	HBP1400-TP	152	A2479	HBP-TP-1600 S/S	152	A2842	SMR-CCB-L73	85	PTM-1050-3		167
A2287	HBP1500-TP	152	A2480	HBP-TP-1800 S/S	152	A2842	SMR-CCB-L73	92	PTM-1050-3-S/S		168
A2288	HBP1600-TP	152	A2481	HBP-TP-2000 S/S	152	A2842	SMR-CCB-L73	105	PTM-1200-1		167
A2289	HBP1800-TP	152	A2482	HBP-TP-2200 S/S	152	A2842	SMR-CCB-L73	130	PTM-1200-1-S/S		168
A2290	HBP2000-TP	152	A2483	HBP-TP-2400 S/S	152	A2843	SMR-CCB-R73	85	PTM-1200-2		167
A2291	HBP2200-TP	152	A2484	HBP-TP-2500 S/S	152	A2843	SMR-CCB-R73	92	PTM-1200-2-S/S		168
A2292	HBP2400-TP	152	A2492	HBP900-PL-TP-S/S	153	A2843	SMR-CCB-R73	105	PTM-1200-3		167
A2293	HBP2500-TP	152	A2492	HBP900-PL-TP-S/S	155	A2843	SMR-CCB-R73	130	PTM-1200-3-S/S		168
A2294	HBP900-PL-TP	153	A2493	HBP1050-PL-TP-S/S	153	A2844	SMR-CCB-L60	130	PTM-1350-1		167
A2294	HBP900-PL-TP	155	A2493	HBP1050-PL-TP-S/S	155	A2845	SMR-CCB-R60	130	PTM-1350-1-S/S		168
A2295	HBP1050-PL-TP	153	A2494	HBP1200-PL-TP-S/S	153	A2988	EZP1P24-S/S	18	PTM-1350-2		167
A2295	HBP1050-PL-TP	155	A2494	HBP1200-PL-TP-S/S	155	A3041	EZP1P30-S/S	18	PTM-1350-2-S/S		168
A2296	HBP1200-PL-TP	153	A2495	HBP1400-PL-TP-S/S	153	A3119	EZP1P36-S/S	18	PTM-1350-3		167
A2296	HBP1200-PL-TP	155	A2495	HBP1400-PL-TP-S/S	155	B0092	CBD-ST-MC	157	PTM-1350-3-S/S		168
A2297	HBP1400-PL-TP	153	A2496	HBP1500-PL-TP-S/S	153	B0536		64	PTM-1500-1		167
A2297	HBP1400-PL-TP	155	A2496	HBP1500-PL-TP-S/S	155	G1211	HEX NUT	43	PTM-1500-2		167
A2298	HBP1500-PL-TP	153	A2497	HBP1600-PL-TP-S/S	153	G1211	HEX NUT	74	PTM-1500-3		167
A2298	HBP1500-PL-TP	155	A2497	HBP1600-PL-TP-S/S	155	G1211	HEX NUT	79	PTM-1600-1		167
A2299	HBP1600-PL-TP	153	A2498	HBP1800-PL-TP-S/S	153	G1211	HEX NUT	99	PTM-1600-1-S/S		168
A2299	HBP1600-PL-TP	155	A2498	HBP1800-PL-TP-S/S	155	G2309	MST LOCK PIN SS	118	PTM-1600-2		167
A2300	HBP1800-PL-TP	153	A2499	HBP2000-PL-TP-S/S	153	GR298		64	PTM-1600-2-S/S		168
A2300	HBP1800-PL-TP	155	A2499	HBP2000-PL-TP-S/S	155	ULP1050	66126	125	PTM-1600-3		167
A2301	HBP2000-PL-TP	153	A2500	HBP2200-PL-TP-S/S	153	ULP1200	66127	125	PTM-1600-3-S/S		168
A2301	HBP2000-PL-TP	155	A2500	HBP2200-PL-TP-S/S	155	ULP1350	66128	125	PTM-1800-1		167
A2302	HBP2400-PL-TP	153	A2501	HBP2400-PL-TP-S/S	153	ULP1500	66129	125	PTM-1800-1-S/S		168
A2302	HBP2400-PL-TP	155	A2501	HBP2400-PL-TP-S/S	155	ULP1650	66130	125	PTM-1800-2		167
A2303	HBP2200-PL-TP	153	A2502	HBP2500-PL-TP-S/S	153	ULP1800	67057	125	PTM-1800-2-S/S		168
A2303	HBP2200-PL-TP	155	A2502	HBP2500-PL-TP-S/S	155	ULP2000	67084	125	PTM-1800-3		167
A2304	HBP2500-PL-TP	153	A2504	HBP900-MF-TP-S/S	153	ULP2200	67085	125	PTM-1800-3-S/S		168
A2304	HBP2500-PL-TP	155	A2505	HBP1050-MF-TP-S/S	153	ULP2400	67058	125	PTM-2000-1		167
A2305	HBP900-MF-TP	153	A2506	HBP1200-MF-TP-S/S	153	ULP2600	67086	125	PTM-2000-1-S/S		168
A2306	HBP1050-MF-TP	153	A2507	HBP1400-MF-TP-S/S	153	ULP2800	67087	125	PTM-2000-2		167
A2307	HBP1200-MF-TP	153	A2508	HBP1500-MF-TP-S/S	153	ULP3000	67088	125	PTM-2000-2-S/S		168
A2308	HBP1400-MF-TP	153	A2509	HBP1600-MF-TP-S/S	153	ULP450	66122	125	PTM-2000-3		167
A2309	HBP1500-MF-TP	153	A2510	HBP1800-MF-TP-S/S	153	ULP600	66123	125	PTM-2000-3-S/S		168
A2310	HBP1600-MF-TP	153	A2511	HBP2000-MF-TP-S/S	153	ULP750	66124	125	PTM-2400-1		167
A2311	HBP1800-MF-TP	153	A2512	HBP2200-MF-TP-S/S	153	ULP900	66125	125	PTM-2400-1-S/S		168
A2312	HBP2000-MF-TP	153	A2513	HBP2400-MF-TP-S/S	153			174	PTM-2400-2		167
A2313	HBP2400-MF-TP	153	A2514	HBP2500-MF-TP-S/S	153			174	PTM-2400-2-S/S		168
A2314	HBP2200-MF-TP	153	A2515	HBP-LA-TP-S/S	153			174	PTM-2400-3		167
A2315	HBP2500-MF-TP	153	A2518	HDSTKD	42			174	PTM-2400-3-S/S		168
A2316	HBP900-B-TP	153	A2519	HDSTKD-S/S	42			175	PTM-2600-1		167
A2317	HBP1050-B-TP	153	A2527	RPHD2100	68			175	PTM-2600-1-S/S		168
A2318	HBP1200-B-TP	153	A2590	HPHD2400-S/S	42			175	PTM-2600-2		167

INDEX By Item Code

Item Code	Ordering Number	Page #	Item Code	Ordering Number	Page #	Item Code	Ordering Number	Page #	Item Code	Ordering Number	Page #
	PTM-2600-2-S/S	168		PTM-750-2-S/S	168		RS-1-15-42-35	174		SC-7-48	174
	PTM-2600-3	167		PTM-750-3	167		RS-1-15-48-35	174		SC-7-54	174
	PTM-2600-3-S/S	168		PTM-750-3-S/S	168		RS-1-15-54-35	174		SC-7-60	174
	PTM-3000-1	167		PTM-900-1	167		RS-1-15-60-35	174		SC-7-66	174
	PTM-3000-1-S/S	168		PTM-900-1-S/S	168		RS-1-15-66-35	174		SC-7-72	174
	PTM-3000-2	167		PTM-900-2	167		RS-1-15-72-35	174		SC-7-84	174
	PTM-3000-2-S/S	168		PTM-900-2-S/S	168		RS-1-15-84-35	174		SC-7-96	174
	PTM-3000-3	167		PTM-900-3	167		RS-1-15-96-35	174		SP-24	175
	PTM-3000-3-S/S	168		PTM-900-3-S/S	168		SC-7-24	174		SP-48	175
	PTM-750-1	167		RS-1-15-24-35	174		SC-7-30	174		SP-72	175
	PTM-750-1-S/S	168		RS-1-15-30-35	174		SC-7-36	174		SP-96	175
	PTM-750-2	167		RS-1-15-36-35	174		SC-7-42	174			



Partners in Productivity

10 Solent Circuit
Norwest NSW 2153

Phone: +61 2-8818-2000 Fax: +61 2-8824-6333

Toll Free: 1300 098 435

E-mail: salesau@flexco.com

www.flexco.com