

FMS Flexco Secondary Cleaner

Reliable Cleaning at an Affordable Price

The FMS Secondary Belt Cleaner features carbide blades, self-adjusting spring tensioners and unique cushions that independently tension each blade to the belt. This simple but durable design provides quality cleaning performance at an affordable price.

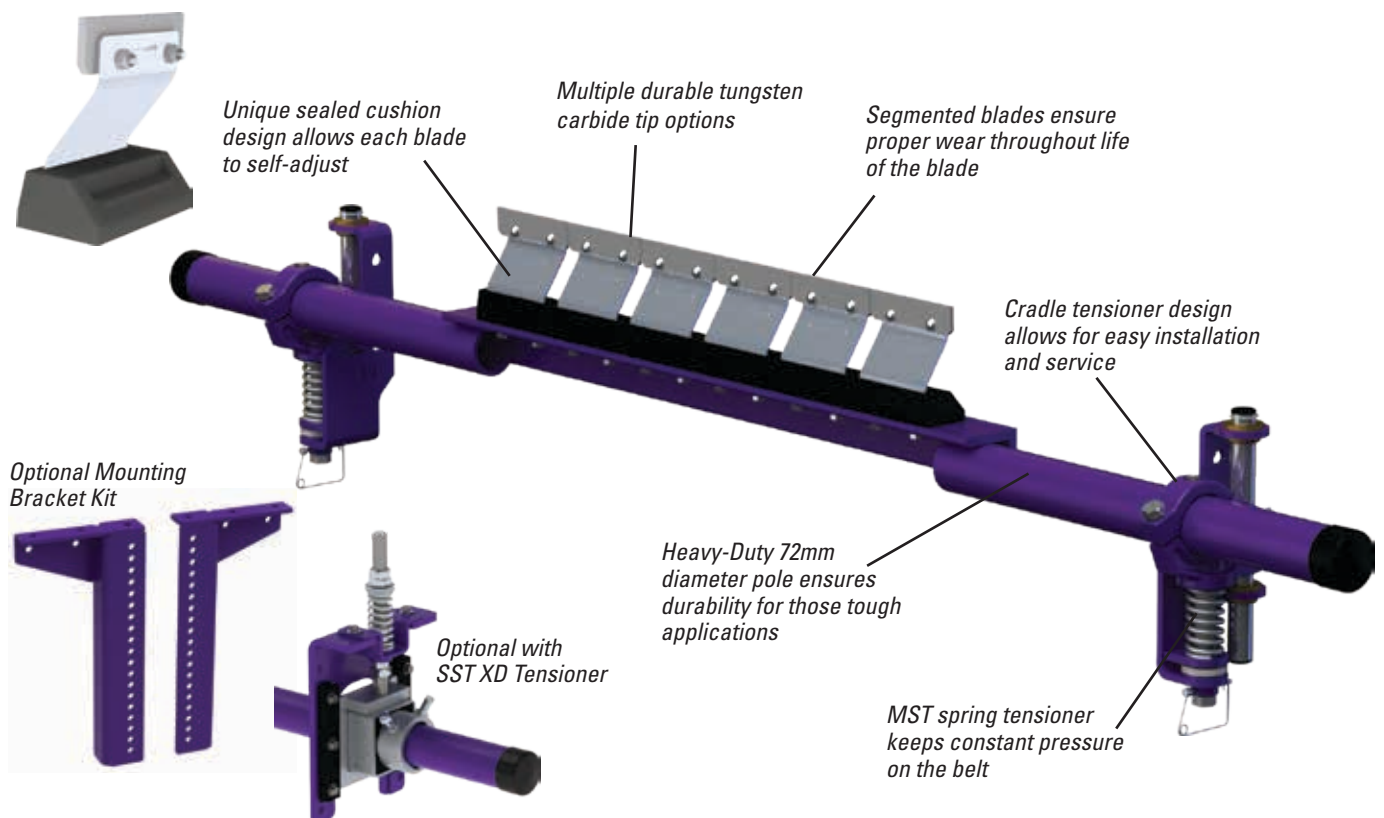

Features and Benefits

- **Made for mining conveyors.** Made from heavy-duty steel with corrosion-resistant powder coating, the FMS is available in sizes for belt widths from 450 to 1800mm. Additional sizes are available upon request.
- **For belt speeds up to 5m/s.**
- **Compact spring tensioner.** Utilizes the MST tensioner to maintain constant pressure on the belt.
- **Cleaning efficiency of metal blades.** The thin, hard edges of the 6" (150mm) wide metal blades deliver high cleaning efficiency and long wear life.
- **Works with Flexco mechanical splices.** The C-Tip tungsten carbide blades are impact-resistant, and the spring cushion allows them to move away from a passing splice without damage and with minimal cleaning disruption. V-Tips can be used only on vulcanized belts.
- **A complete cleaning system.** When the FMS is teamed with the MSP or MMP Precleaner the system provides excellent cleaning power for tough applications.

FMS Secondary Cleaner

Specifications and Guidelines

Maximum Belt Speed

5 m/s

Temperature Rating

-35° C to 148° C

Usable Blade Wear Length

9 mm

Available for Belt Widths

450 to 1800 mm

Blade Material

Impact resistant, long-lasting tungsten carbide (C-Tips for mechanical fasteners, V-Tips for vulcanized belts)

CEMA Cleaner Rating

Class 4

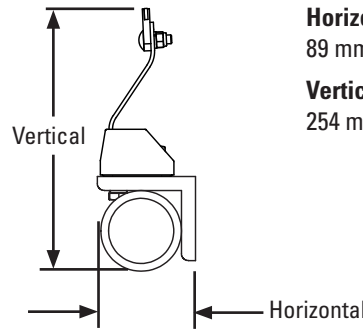

Horizontal Clearance Required

89 mm

Vertical Clearance Required

254 mm

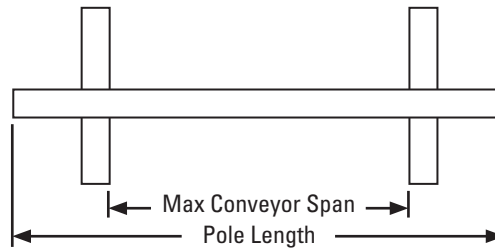

Pole Length

Belt width + 1350 mm

Maximum Conveyor Span

Belt width + 1100 mm

Ordering Information

FMS with MST Secondary with C-Tips			
Belt Width		Complete Cleaner	
mm	in.	Ordering Number	Item Code
450	18	FMS-18	79637
600	24	FMS-24	79638
750	30	FMS-30	79639
900	36	FMS-36	79640
1050	42	FMS-42	79641
1200	48	FMS-48	79642
1350	54	FMS-54	79643
1500	60	FMS-60	79644
1800	72	FMS-72	79645

Lead time: 1 working day

FMS with MST Secondary with V-Tips			
Belt Width		Complete Cleaner	
mm	in.	Ordering Number	Item Code
450	18	FMS-18V	79646
600	24	FMS-24V	79647
750	30	FMS-30V	79648
900	36	FMS-36V	79649
1050	42	FMS-42V	79650
1200	48	FMS-48V	79651
1350	54	FMS-54V	79652
1500	60	FMS-60V	79653
1800	72	FMS-72V	79654

Lead time: 1 working day

FMS with SSTXD Secondary with C-Tips			
Belt Width		Complete Cleaner	
mm	in.	Ordering Number	Item Code
450	18	FMS-18-SSTXD	92185
600	24	FMS-24-SSTXD	92186
750	30	FMS-30-SSTXD	92187
900	36	FMS-36-SSTXD	92188
1050	42	FMS-42-SSTXD	92189
1200	48	FMS-48-SSTXD	92190
1350	54	FMS-54-SSTXD	92191
1500	60	FMS-60-SSTXD	92192
1800	72	FMS-72-SSTXD	92193

Lead time: 1 working day

FMS with SSTXD Secondary with V-Tips			
Belt Width		Complete Cleaner	
mm	in.	Ordering Number	Item Code
450	18	FMS-18V-SSTXD	92194
600	24	FMS-24V-SSTXD	92195
750	30	FMS-30V-SSTXD	92196
900	36	FMS-36V-SSTXD	92197
1050	42	FMS-42V-SSTXD	92198
1200	48	FMS-48V-SSTXD	92199
1350	54	FMS-54V-SSTXD	92200
1500	60	FMS-60V-SSTXD	92201
1800	72	FMS-72V-SSTXD	92202

Lead time: 1 working day

Replacement Tips	
Ordering Number	Item Code
ICT6 (C-Tip)	74535
RSA150 (V-Tip)	73628

Replacement Cushion	
Ordering Number	Item Code
FMSC	79699

Drop Bracket Kit	
Ordering Number	Item Code
MSTDB	79434
SSTSMB	76071
SSTLMB	76072

Blades Required per Cleaner Size										
mm	450	600	750	900	1050	1200	1350	1500	1800	
Blades Required	3	4	5	6	7	8	9	10	12	



Authorized Distributor:

Flexco Europe GmbH • Maybachstrasse 9 • 72348 Rosenfeld • Germany
Tel: +49-7428-9406-0 • Fax: +49-7428-9406-260 • E-mail: europe@flexco.com

Visit www.flexco.com for other Flexco locations and products.

©2021 Flexible Steel Lacing Company. 04/15/21. For reorder: X6103

