

# MMP OE Medium-Duty Precleaner

## Economical and Effective Choice for Wood Handling

The MMP OE Medium-Duty Precleaner is a tough design that combines simple, do-it-yourself installation, quick maintenance and effective cleaning results with an affordable price tag. Install the MMP OE on belts carrying chips where dust is widespread to facilitate the capture of usable material and avoid material piles that create fire hazards. Stainless Steel components are available for belts carrying chips to the digester and lime to the kiln.

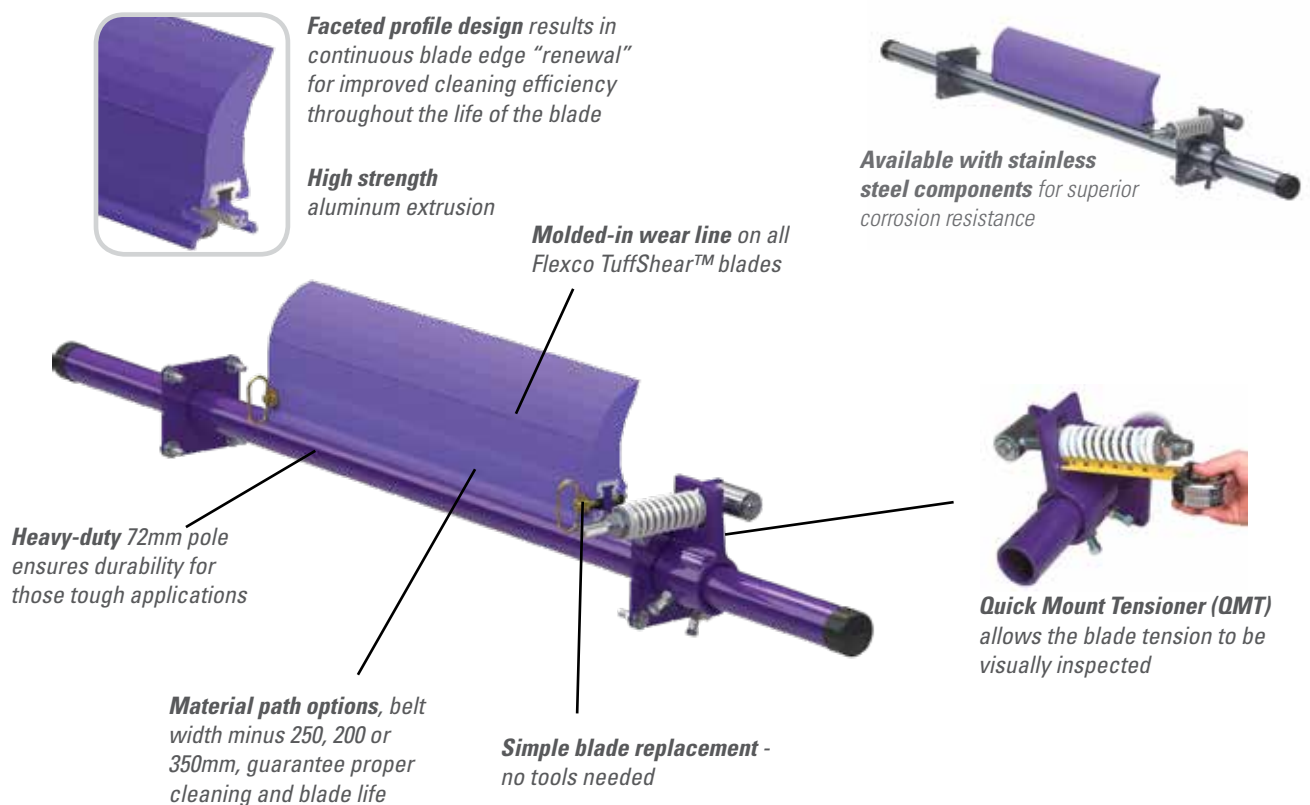

## Features and Benefits

- **Quick-change blade.** No tools are needed. Just pull one pin, remove the old blade, slide in the new one and replace the pin.
- **Works with Flexco and other mechanical splices.** The spring tensioner quickly moves the blade away from the belt when a splice passes. The polyurethane blade easily glides over the splice without damage and with minimal cleaning disruption.
- **Easy to service.** All maintenance work is done from the easy-access side of the beltline. Blade retensioning and changeout are quick and easy.
- **Fits most conveyor structures.** Available for belt widths from 600 to 2100mm. The MMP OE poles are extra long (belt width plus 1350 mm) to accommodate varying structure widths.

# MMP OE Medium-Duty Precleaner

## Specifications and Guidelines

- Maximum Belt Speed**  
5 M/sec
- Temperature Rating**  
-35°C to 82°C
- Minimum Pulley Diameter**  
400mm
- Blade Height**  
250mm
- Usable Blade Wear Length**  
150mm
- Blade Material**  
**Purple/White:** Polyurethane 83 durometer (proprietary blend for abrasion resistance and long wear)
- Available for Belt Widths**  
600 to 2100mm
- CEMA Cleaner Rating**  
Class 3
- Horizontal Clearance Required**  
100mm
- Vertical Clearance Required**  
325mm
- Pole Length**  
Cleaner size + 1350mm
- Maximum Conveyor Span**  
Cleaner size + 1050mm

### Pole Location Specs

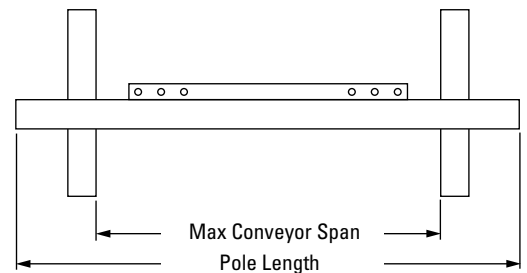
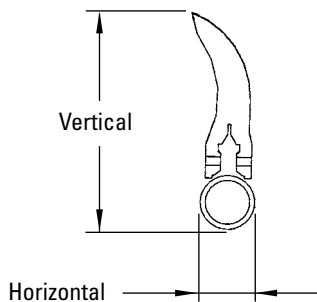
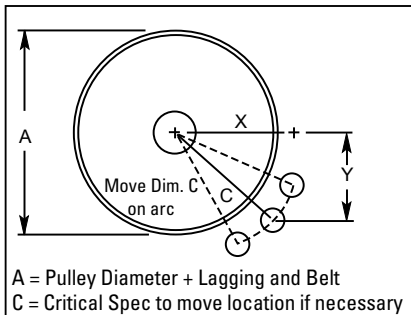

### Pole Location Chart

A	X	Y	C	A	X	Y	C	A	X	Y	C
400	204	305	367	625	314	230	390	850	446	230	501
425	218	305	375	650	330	230	402	875	460	230	514
450	231	305	383	675	346	230	415	900	474	230	526
475	244	305	390	700	360	230	427	925	488	230	539
500	259	305	400	725	374	230	439	950	502	230	552
525	274	305	410	775	389	230	452	975	516	230	565
550	288	305	419	775	403	230	464	1000	529	230	576
575	300	305	428	825	417	230	477	1025	542	230	589
600	315	305	438	825	432	230	489	1050	557	230	602

### Ordering Information

MMP OE Medium-Duty Precleaner Belt Width Minus 150mm (6")		
Belt Width mm	Ordering Number	Item Code
600	MMPU600-150	83751
750/800	MMPU750-150	83752
900	MMPU900-150	83753
1000/1050	MMPU1050-150	83754
1200	MMPU1200-150	83755
1350	MMPU1350-150	83756
1500	MMPU1500-150	83757
1600/1650	MMPU1650-150	83758
1800	MMPU1800-150	83759

MMP OE Medium-Duty Precleaner Belt Width Minus 300mm (12")		
Belt Width mm	Ordering Number	Item Code
750/800	MMPU750-300	83877
900	MMPU900-300	83878
1000/1050	MMPU1050-300	83879
1200	MMPU1200-300	83880
1350	MMPU1350-300	83881
1500	MMPU1500-300	83882
1600/1650	MMPU1650-300	83883
1800	MMPU1800-300	83884
2100	MMPU2100-300	83885

### TuffShear™ Replacement Blades

Blade Width mm	Ordering Number	Item Code
450	TRB18	76485
600	TRB24	76486
750	TRB30	76487
900	TRB36	76488
1050	TRB42	76489
1200	TRB48	76490
1350	TRB54	76491
1500	TRB60	76492
1650	TRB66	76493
1800	TRB72	76494

Authorised Distributor: