

# Motorized Brush Cleaner

## Effectively Cleans Stubborn Wood Dust off Chevron Belts

Chevron belts present a special problem for efficient cleaning especially when chips and bark are wet. There is more surface area and cavities for fines to stick to, and a traditional flat blade cleaner will not effectively clean the belt's surface. The Motorized Brush Cleaner is an ideal option for cleaning stubborn wood dust off these belts.

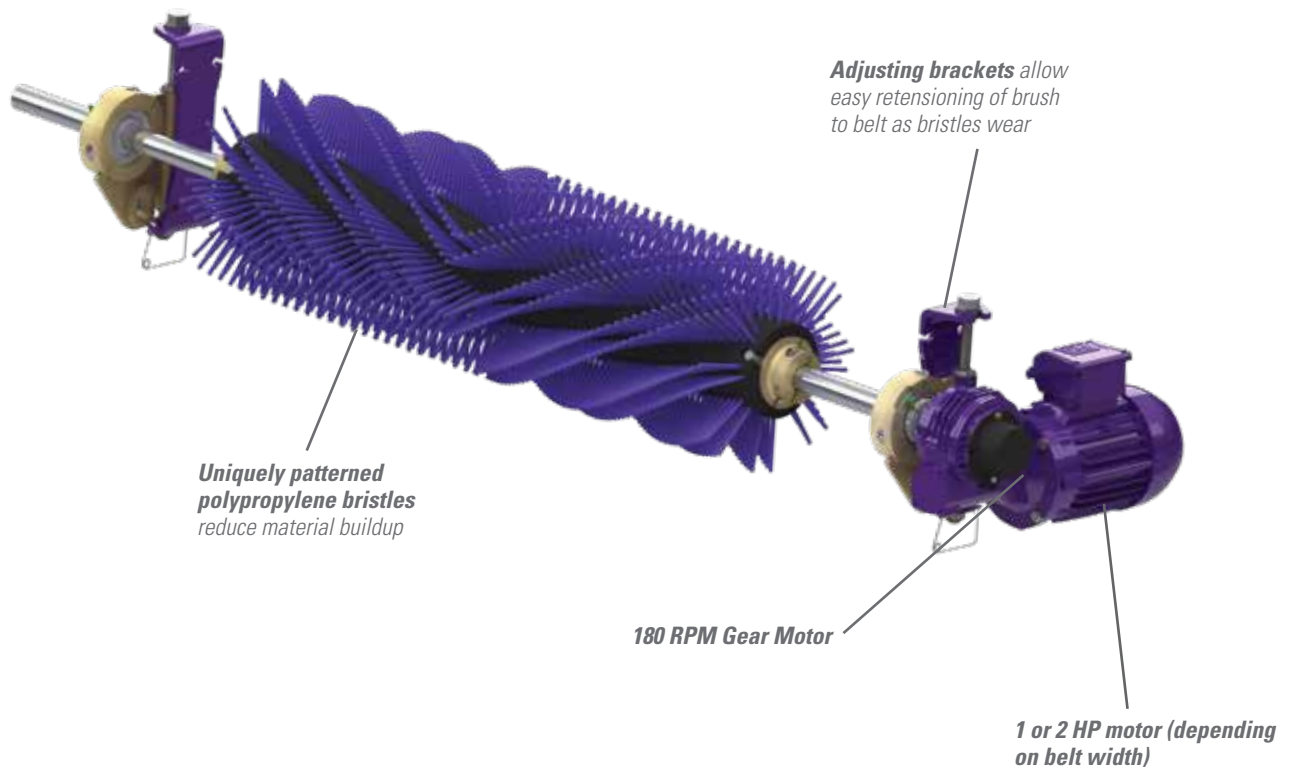

### Features and Benefits

- **Maximum Cleaning.** Spins opposite the belt direction for optimal cleaning.
- **Uniquely patterned bristles.** Aids in reducing material buildup and clogging.
- **Adjustable tensioners.** Allows easy brush-to-belt adjustment as the bristles wear.
- **Works on mechanically spliced or vulcanized belts.**

# MOTORIZED BRUSH CLEANER

## Specifications and Guidelines

- **Maximum Belt Speed**  
3.5 M/sec
- **Temperature Rating**  
-30° C to 82° C
- **CEMA Cleaner Rating**  
Class 4
- **Overall Brush Diameter**  
305mm
- **Bristle Material**  
Polypropylene
- **Bristle Length**  
83mm
- **Brush RPM**  
180
- **Shaft Diameter**  
38mm
- **Shaft Length**  
Belt Width + 1067mm
- **Maximum Chevron or Cleat Height**  
13mm
- **Motor Voltage and HP**  
**208-230/460VAC 3 Phase\***  
1HP (Cleaners 450-1050mm)  
2HP (Cleaners 1200-2100mm)  
**575V 3 Phase\***  
1HP (Cleaners 450-900mm)  
2HP (Cleaners 1050-2100mm)  
\*other motors available upon request
- **Available for Belt Widths**  
450 to 2100mm
- **Horizontal Clearance Required**  
305mm
- **Vertical Clearance Required**  
305mm

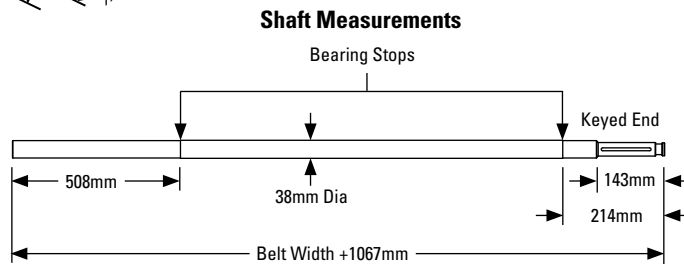
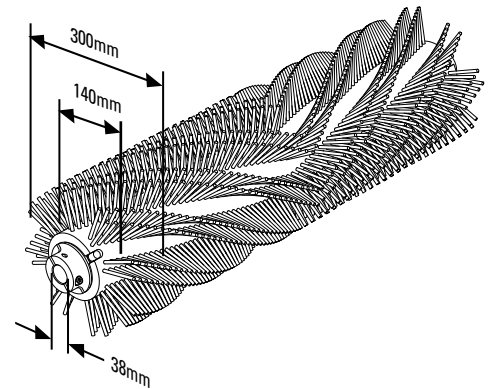
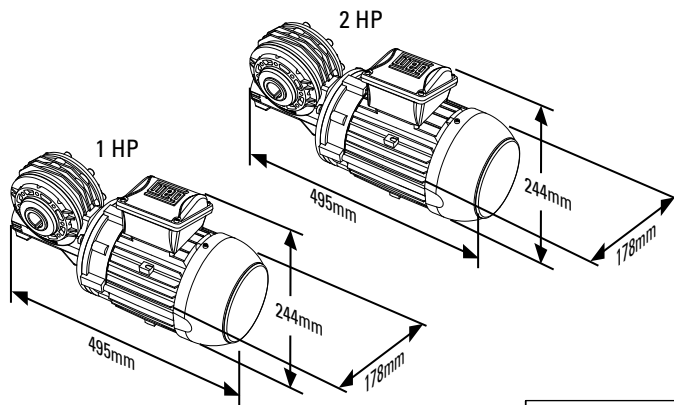

## Ordering Information

Motorized Brush Cleaner 208-230/460 VAC 3-Phase Motor			
Belt Width	Brush Coverage	Ordering Number	Item Code
450	450	MBC-18	79494
600	600	MBC-24	79495
750	750	MBC-30	79496
900	900	MBC-36	79497
1050	1050	MBC-42	79498
1200	1200	MBC-48	79499
1350	1350	MBC-54	79500
1500	1500	MBC-60	79501
1800	1800	MBC-72	79502
2100	2100	MBC-84	79503

Motorized Brush Cleaner 575V 3-Phase Motor			
Belt Width	Brush Coverage	Ordering Number	Item Code
450	450	MBC-18-575V	79914
600	600	MBC-24-575V	79915
750	750	MBC-30-575V	79916
900	900	MBC-36-575V	79917
1050	1050	MBC-42-575V	79918
1200	1200	MBC-48-575V	79919
1350	1350	MBC-54-575V	79920
1500	1500	MBC-60-575V	79921
1800	1800	MBC-72-575V	79922
2100	2100	MBC-84-575V	79923

Replacement Brushes	
Ordering Number	Item Code
MBRD-18	79514
MBRD-24	79515
MBRD-30	79516
MBRD-36	79517
MBRD-42	79518
MBRD-48	79519
MBRD-54	79520
MBRD-60	79521
MBRD-72	79522
MBRD-84	79523

Lead time: 1 working day

Authorised Distributor: