

# EZP1 Rockline® Standard-Duty Precleaner

## Simple, Quick, Effective Belt Cleaning for Pulp and Paper Operations

The EZP1 Precleaner is not your average solid-blade belt cleaner that mounts on the head pulley. It features a unique single blade design that combines simple, do-it-yourself installation, quick maintenance, and effective cleaning with a price tag that you can afford. Install the EZP1 on belts carrying bark or chips where dust is widespread to facilitate the capture of usable material and avoid material piles that create fire hazards. Stainless Steel components and Chemical-Resistant, High-Temp, or Ultra-High Temp blade options are available for belts carrying chips to the digester and lime to the kiln.



**Faceted profile design** results in continuous blade edge "renewal" for improved cleaning efficiency throughout the life of the blade

**High strength** aluminum extrusion



**Pole plate pre-drilled** for material path options, 3 different blade widths available



**Available with stainless steel components** for superior corrosion resistance



**Chemical-Resistant Blade**



**High-Temp Blade**  
135° C (275° F) with spikes to 160° C (325° F)



**Ultra High-Temp Blade**  
200° C (400° F) with spikes to 230° C (450° F)

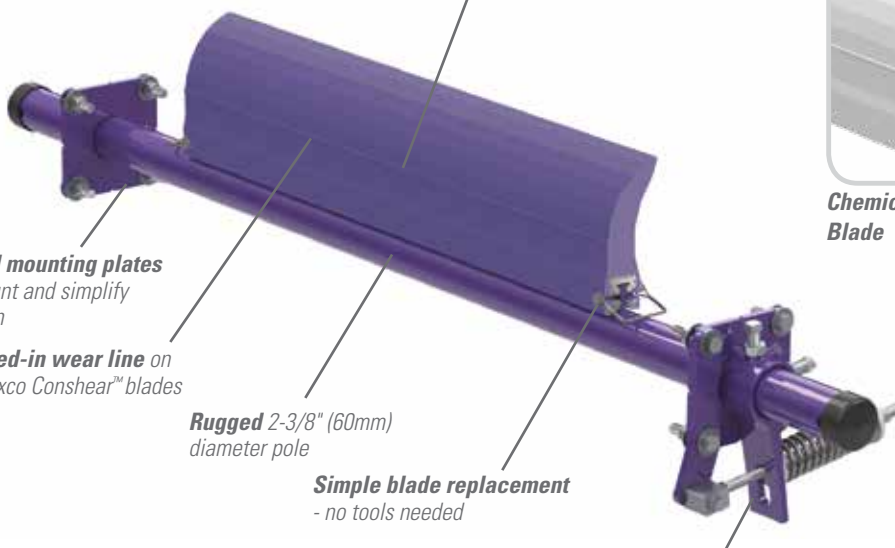

**Universal mounting plates** easily mount and simplify installation

**Molded-in wear line** on all Flexco ConShear™ blades

**Rugged 2-3/8" (60mm)** diameter pole

**Simple blade replacement** - no tools needed

**Self-contained spring tensioner** allows for measurable and verifiable tension

## Features and Benefits

- **Works with Flexco mechanical splices.** The spring tensioner allows the blade to quickly move away from the belt when a splice passes. The polyurethane blade material easily glides over the splice without damage and with minimal cleaning disruption.
- **Compact, streamlined design.** The EZP1 Precleaner requires only 4" (100 mm) of horizontal clearance for correct installation. Its streamlined contours prevent material buildup on the blade or the pole.
- **Can be used on reversing belts.** Installing cleaners on both pulleys gives superior cleaning results on belts that run in both directions.
- **Fits most conveyor structures.** Available for belt widths from 12" to 72" (300-1800 mm).
- **Blade can be used on other cleaners.** The ConShear™ blade can be used as a replacement blade on many OEM cleaners.

# EZP1

## Rockline® Standard-Duty Precleaner

### Specifications and Guidelines

- Maximum Belt Speed**  
700 FPM (3.5 M/sec)
- Temperature Rating**  
**Purple/White:** -30°F to 180°F (-35°C to 82°C)  
**Yellow:** -30°F to 275°F (-35°C to 135°C)  
Spikes to 325°F (160°C)  
**Red:** -30°F to 400°F (-35°C to 200°C)  
Spikes to 450°F (230°C)
- Minimum Pulley Diameter**  
10" (250 mm)
- Blade Height**  
7-1/4" (185 mm)
- Usable Blade Wear Length**  
4" (100 mm)
- Blade Material**  
**Purple/White:** Polyurethane 83 durometer  
**Yellow:** Polyurethane 93 durometer  
**Red:** Ultra High-Temp Polyurethane 90 durometer
- CEMA Cleaner Rating**  
Class 3
- Available for Belt Widths**  
12" to 72" (300 to 1800 mm)
- Horizontal Clearance Required**  
4" (100 mm)
- Vertical Clearance Required**  
9-1/2" (238 mm)
- Pole Length**  
Cleaner size up to 48" + 30"  
Cleaner size over 48" + 34"  
(Cleaner size up to 1200mm + 750mm)  
(Cleaner size over 1200mm + 850mm)
- Maximum Conveyor Span**  
Cleaner size up to 48" + 25"  
Cleaner size over 48" + 29"  
(Cleaner size up to 1200mm + 625mm)  
(Cleaner size over 1200mm + 725mm)

#### Pole Location Specs

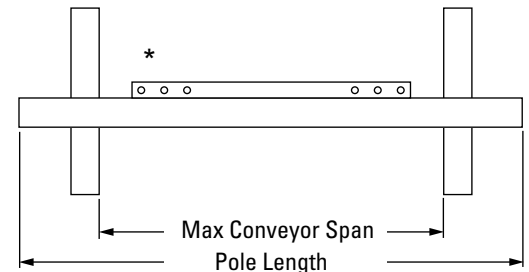
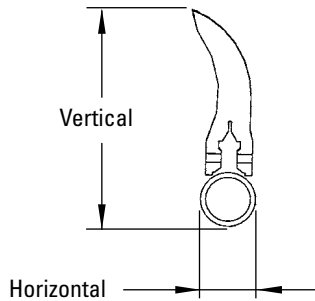
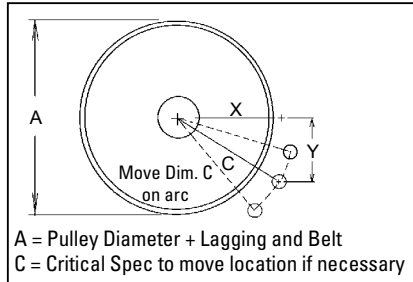

#### Pole Location Chart

A	X	Y	C	A	X	Y	C	A	X	Y	C
10"	3"	9"	9-1/2"	19"	9"	9"	12-3/4"	28"	14-3/8"	9"	17"
11"	3-3/4"	9"	9-3/4"	20"	9-3/8"	9"	13"	29"	15"	9"	17-1/2"
12"	4-3/8"	9"	10"	21"	10"	9"	13-1/2"	30"	15-5/8"	9"	18"
13"	5-3/8"	9"	10-1/2"	22"	10-3/4"	9"	14"	31"	16-1/8"	9"	18-1/2"
14"	5-7/8"	9"	10-3/4"	23"	11-3/8"	9"	14-1/2"	32"	16-3/4"	9"	19"
15"	6-3/4"	9"	11-1/4"	24"	12"	9"	15"	33"	17-1/4"	9"	19-1/2"
16"	7-1/8"	9"	11-1/2"	25"	12-5/8"	9"	15-1/2"	34"	17-7/8"	9"	20"
17"	7-7/8"	9"	12"	26"	13-1/4"	9"	16"	35"	18-3/8"	9"	20-1/2"
18"	8-1/4"	9"	12-1/4"	27"	13-7/8"	9"	16-1/2"	36"	19"	9"	21"



### Ordering Information

EZP1 Precleaners - Belt Width -2" (50mm) Blade					
Belt Width		Blade Coverage		Ordering Number	Item Code
in.	mm	in.	mm		
12	300	10	250	EZP1-212	75610
18	450	16	400	EZP1-218	75611
24	600	22	550	EZP1-224	75612
30	750	28	700	EZP1-230	75613
36	900	34	850	EZP1-236	75614
42	1050	40	1000	EZP1-242	75615
48	1200	46	1150	EZP1-248	75616
54	1350	52	1300	EZP1-254	75617
60	1500	58	1450	EZP1-260	75618
72	1800	70	1750	EZP1-272	75771

EZP1 Precleaners - Belt Width -8" (200mm) Blade					
Belt Width		Blade Coverage		Ordering Number	Item Code
in.	mm	in.	mm		
12	300	-	-	N/A	N/A
18	450	10	250	EZP1-818	75779
24	600	16	400	EZP1-824	75780
30	750	22	550	EZP1-830	75781
36	900	28	700	EZP1-836	75782
42	1050	34	850	EZP1-842	75783
48	1200	40	1000	EZP1-848	75784
54	1350	46	1150	EZP1-854	75785
60	1500	52	1300	EZP1-860	75786
72	1800	64	1600	EZP1-872	75774

ConShear™ Replacement Blades			
Blade Width		Ordering Number	Item Code
in.	mm		
10	250	CRB10	75628
16	400	CRB16	75629
22	550	CRB22	75630
28	700	CRB28	75631
34	850	CRB34	75632
40	1000	CRB40	75633
46	1150	CRB46	75634
52	1300	CRB52	75635
58	1450	CRB58	75636
64	1600	CRB64	75775
70	1750	CRB70	75773



Ordering information shown is for the standard mild steel EZP1 with purple blade.  
Contact your Flexco distributor or visit [www.flexco.com](http://www.flexco.com) for other cleaner/blade options.

Authorized Distributor:

