

Y-Type™ Polyurethane and Carbide Secondary Cleaner

Simple, Effective Cleaning for Cement Operations Where Dust is Widespread

The Y-Type™ Secondary Cleaner should be installed throughout the cement process, especially in areas such as the materials storage and proportioning and finish mills, where dust is widespread. With easy, do-it-yourself installation and simple, serviceable blades, all at an affordable price, it makes for the ideal solution to facilitate the capture of usable materials.

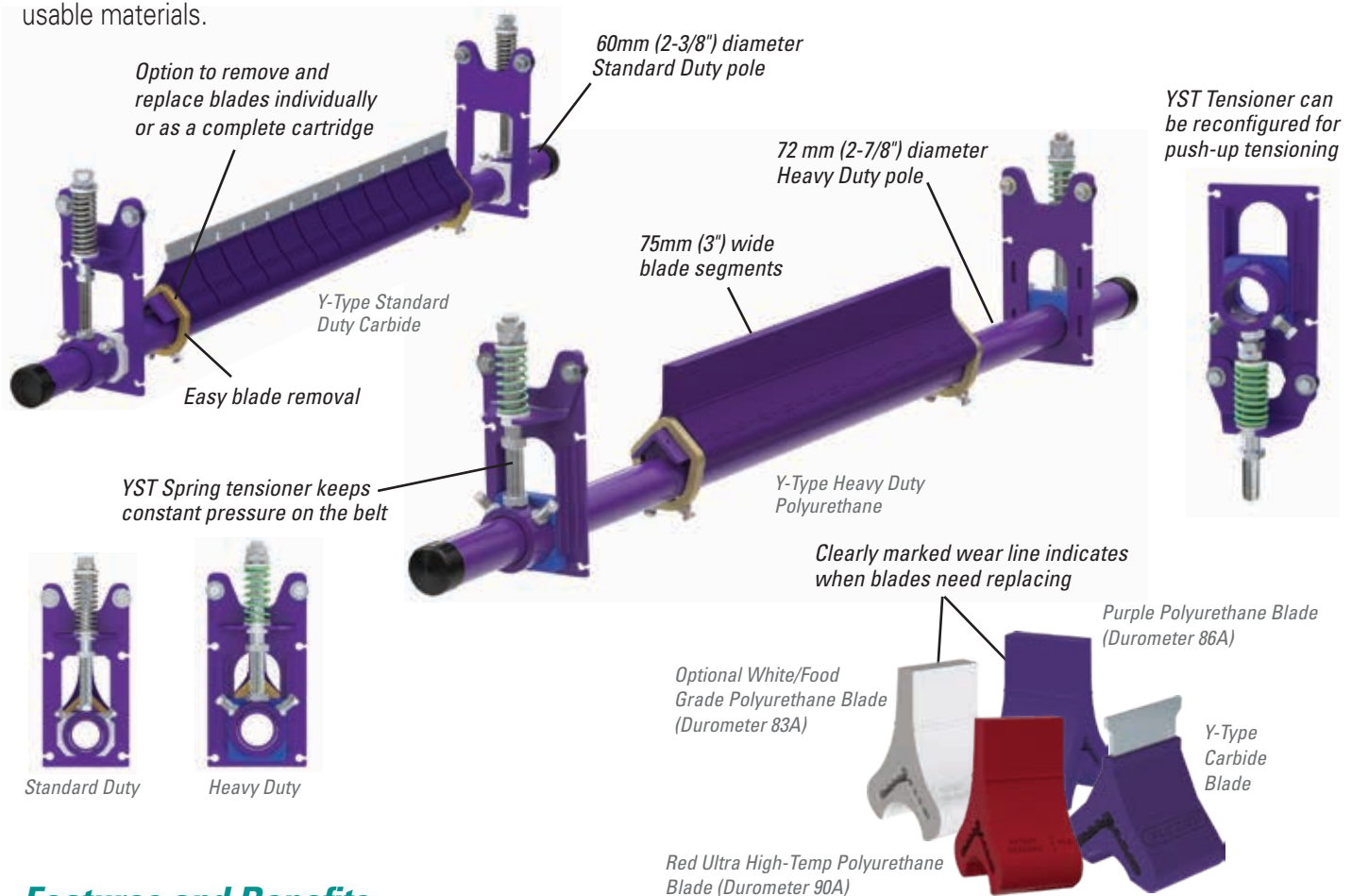

Features and Benefits

- Belt speeds up to 3 m/s (600 fpm) for standard duty, up to 3.8 m/s (750 fpm) for heavy duty.
- Works on reversing belts.
- Available in 450 - 1200mm (18" - 48") for standard duty belts, 900 - 1800mm (36" - 72") for heavy duty belts .
- 75mm (3") wide blade segments. Conforms to worn or damaged belts.
- Blades available in carbide and purple or white/food grade polyurethane.
- **Easy maintenance.** Simple design makes changing the blades fast and easy. Blades can be removed and replaced individually, or all at once by replacing the cartridge.
- **Spring tensioner.** Utilizes the YST tensioner to maintain constant pressure on the belt. Standard duty YST for 60mm (2-3/8") poles, heavy duty YST for 73mm (2-7/8") poles.

Y-Type™ Polyurethane and Carbide Secondary Cleaner

Specifications and Guidelines

	Standard Duty	Heavy Duty
Maximum Belt Speed	3 m/s (600 FPM)	3.8 m/s (750 FPM)
Temperature Rating	Purple, White, Carbide: -35° C to 82° C (-30° F to 180° F) Red UHT: up to 200° C (400° F) with spikes to 232° C (450° F)	
Usable Blade Wear Length	Polyurethane: 50 mm (2")	Polyurethane: 75 mm (3")
	Carbide: 6 mm (1/4")	Carbide: 10 mm (3/8")
Available for Belt Widths	450 to 1200 mm (18" to 48")	900 to 1800 mm (36" to 72")

Blade Material

Purple: Polyurethane (proprietary blend for abrasion resistance and long wear)

White: Polyurethane (chemical resistant/food grade)*

Red: Polyurethane (ultra high-temp)

Carbide: Impact resistant tungsten carbide

*All ingredients used in polyurethane formulation comply with the relevant requirements of 21 CFR (FDA Code of Federal Regulations) for use in repeated bulk dry food applications.

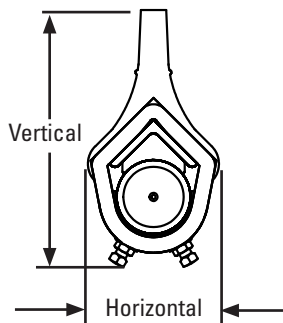

Horizontal Clearance Required

Standard Duty: 110 mm (4-1/4")

Heavy Duty: 135 mm (5-1/4")

Vertical Clearance Required

Standard Duty:

Polyurethane: 210 mm (8-1/4")

Carbide: 185mm (7-3/4")

Heavy Duty:

Polyurethane: 240 mm (9-1/2")

Carbide: 250 mm (9-3/4")

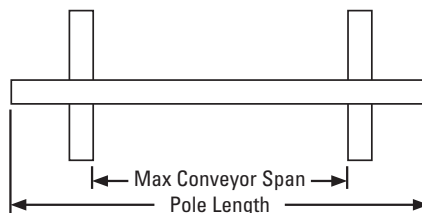

Pole Length

SD Belt width + 762 mm (30")

HD Belt width + 1372 mm (54")

Maximum Conveyor Span

SD Belt width + 559 mm (22")

HD Belt width + 1169 mm (46")

Ordering Information

Y-Type Secondary Cleaners - Standard Duty

Belt Width		Carbide Blades		Purple Polyurethane Blades		White/Food Grade Polyurethane Blades		Red/Ultra High-Temp Polyurethane Blades	
mm	in.	Ordering Number	Item Code	Ordering Number	Item Code	Ordering Number	Item Code	Ordering Number	Item Code
450	18	YT-TC-18S	79759	YT-18S	79765	YTW-18S	79771	YTR-18S	91798
600	24	YT-TC-24S	79760	YT-24S	79766	YTW-24S	79772	YTR-24S	91799
750	30	YT-TC-30S	79761	YT-30S	79767	YTW-30S	79773	YTR-30S	91800
900	36	YT-TC-36S	79762	YT-36S	79768	YTW-36S	79774	YTR-36S	91801
1050	42	YT-TC-42S	79763	YT-42S	79769	YTW-42S	79775	YTR-42S	91802
1200	48	YT-TC-48S	79764	YT-48S	79770	YTW-48S	79776	YTR-48S	91803

Lead time: 1 working day

Y-Type Secondary Cleaners - Heavy Duty

Belt Width		Carbide Blades		Purple Polyurethane Blades		White/Food Grade Polyurethane Blades		Red/Ultra High-Temp Polyurethane Blades	
mm	in.	Ordering Number	Item Code	Ordering Number	Item Code	Ordering Number	Item Code	Ordering Number	Item Code
900	36	YTHD-TC-36S	79777	YTHD-36S	79783	YTHDW-36S	79789	YTHDR-36S	91816
1050	42	YTHD-TC-42S	79778	YTHD-42S	79784	YTHDW-42S	79790	YTHDR-42S	91817
1200	48	YTHD-TC-48S	79779	YTHD-48S	79785	YTHDW-48S	79791	YTHDR-48S	91818
1350	52	YTHD-TC-54S	79780	YTHD-54S	79786	YTHDW-54S	79792	YTHDR-54S	91819
1500	60	YTHD-TC-60S	79781	YTHD-60S	79787	YTHDW-60S	79793	YTHDR-60S	91820
1800	72	YTHD-TC-72S	79782	YTHD-72S	79788	YTHDW-72S	79794	YTHDR-72S	91821

Lead time: 1 working day

Blades Required per Cleaner Size - Standard

mm	450	600	750	900	1050	1200
in.	18	24	30	36	42	48
Blades Required	6	8	10	12	14	16

Blades Required per Cleaner Size - HD

mm	900	1050	1200	1350	1500	1800
in.	36	42	48	54	60	72
Blades Required	12	14	16	18	20	24

Authorised Distributor:

Unit 7 Kingsmark Freeway • Oakenshaw • Bradford, BD12 7HW • United Kingdom
Tel: +44-1274-600-942 • Fax: +44-1274-673-644 • Email: sales@flexco.co.uk

Visit www.flexco.com for other Flexco locations and products.

©2020 Flexible Steel Lacing Company. 10/07/20. For reorder: X5118

