

MHS

Heavy-Duty Secondary Belt Cleaner

Superior Cleaning on the Toughest Belts

The MHS Heavy-Duty Secondary Belt Cleaner was designed to deliver and maintain superior cleaning efficiency, even on the most demanding, abusive beltlines. The MHS is the new answer to tough belt cleaning problems. It delivers high-efficiency cleaning, long-lasting performance—and with low maintenance.

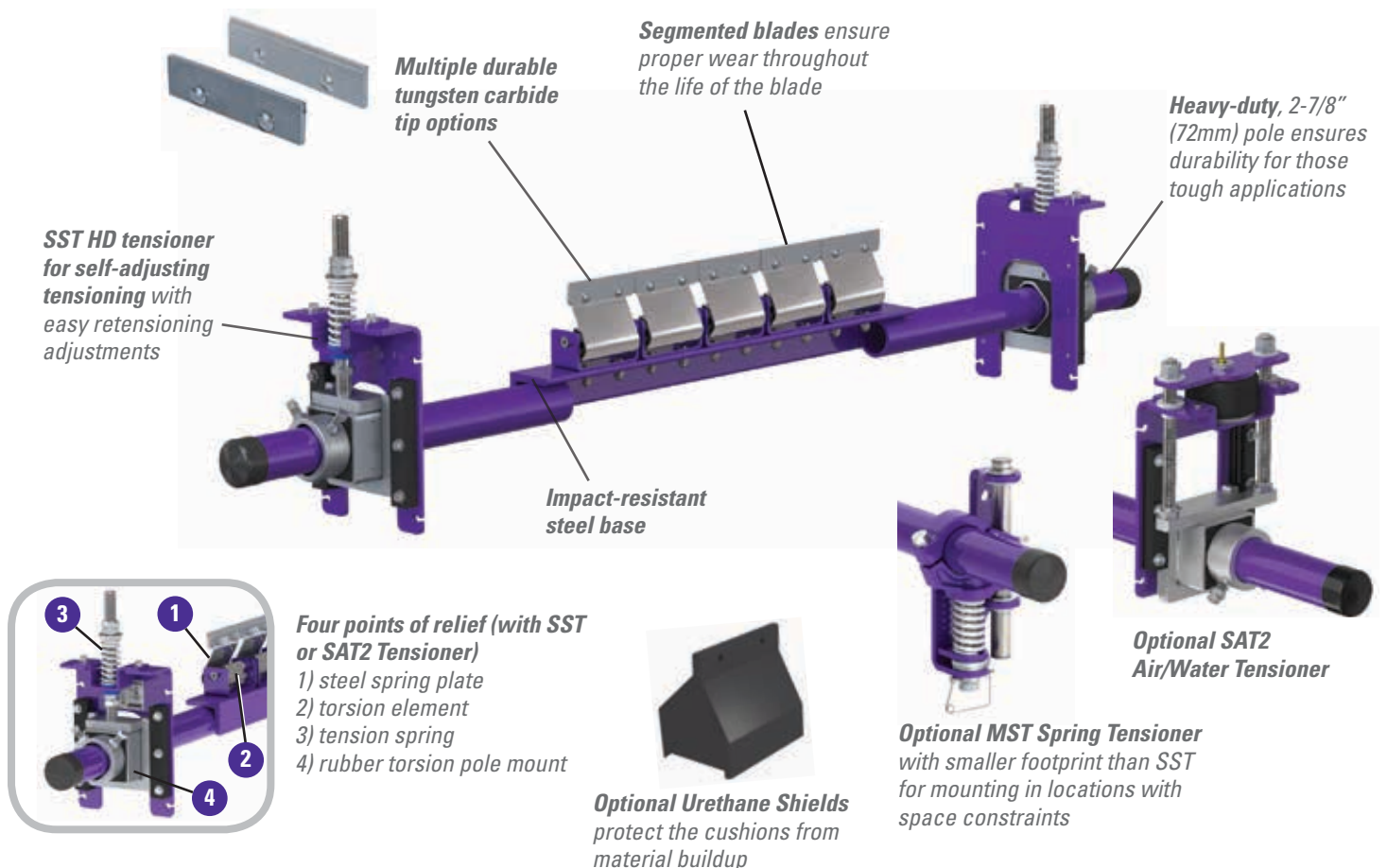

Features and Benefits

- **Cleaning efficiency of metal blades.** The thin, hard edges of the metal blades deliver high cleaning efficiency and long wear life.
- **Works with Flexco mechanical splices.** The C-Tip tungsten carbide blades are impact-resistant, and the spring cushion allows them to move away from a passing splice without damage and with minimal cleaning disruption. V-Tips can be used only on vulcanized belts.
- **A complete cleaning system.** When the MHS is teamed with the MMP precleaner the system provides maximum cleaning power for tough applications.
- **Made for mining conveyors.** Made from heavy-duty, corrosion-resistant steel, the MHS is available in sizes for belt widths from 450 to 2400mm. Additional sizes are available upon request.
- **Safe to service.** All service can be performed from a safe position at the side of the conveyor.
- **Also available in stainless steel.**

MHS Heavy-Duty Secondary Belt Cleaner

Specifications and Guidelines

Maximum Belt Speed

6 m/s
5 m/s with MST Tensioner

Temperature Rating

-35° C to 82° C

Usable Blade Wear Length

9mm

Blade Material

Impact resistant, long-lasting tungsten carbide (C-Tip for mechanical fasteners, V-Tips for vulcanized belts)

Available for Belt Widths

450 to 2400mm with SST or SAT2 Tensioner
450 to 1800mm with MST Tensioner

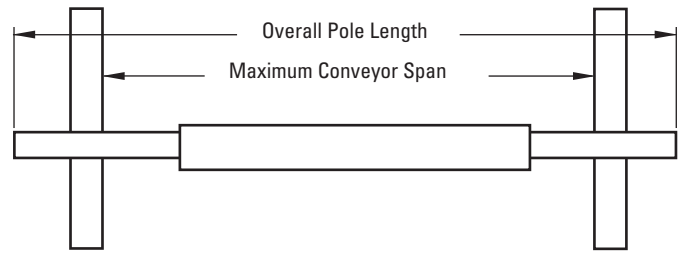

Pole Length Cleaner size +1350mm
Maximum Conveyor Span Cleaner size + 1100mm

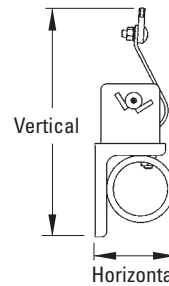

Horizontal Clearance Required
100mm

Vertical Clearance Required
245mm

Ordering Information

MHS HD Secondary with C-Tips

Belt Width	Ordering	Item	
mm	in.	Number	Code
600	24	MHS600	81182
750	30	MHS750	81183
900	36	MHS900	81184
1050	42	MHS1050	81185
1200	48	MHS1200	81186
1350	54	MHS1350	81187
1500	60	MHS1500	81188
1650	66	MHS1650	82493
1800	72	MHS1800	81189
1950	78	MHS1950	82494
2100	84	MHS2100	81190
2250	90	MHS2250	82495
2400	96	MHS2400	82515

MHS HD Secondary with V-Tips*

Belt Width	Ordering	Item	
mm	in.	Number	Code
450	18	MHS450V	81226
600	24	MHS600V	81227
750	30	MHS750V	81228
900	36	MHS900V	81229
1050	42	MHS1050V	81230
1200	48	MHS1200V	81231
1350	54	MHS1350V	81232
1500	60	MHS1500V	81233
1650	66	MHS1650V	82512
1800	72	MHS1800V	81234
1950	78	MHS1950V	82513
2100	84	MHS2100V	81235
2250	90	MHS2250V	82514
2400	96	MHS2400V	82516

*V-Tips can be used ONLY on vulcanized belts

MHS with MST and V-Tips*

Belt Width	Ordering	Item	
mm	in.	Number	Code
450	18	MHS-18V-MST	79442
600	24	MHS-24V-MST	79443
750	30	MHS-30V-MST	79444
900	36	MHS-36V-MST	79445
1050	42	MHS-42V-MST	79446
1200	48	MHS-48V-MST	79447
1350	54	MHS-54V-MST	79448
1500	60	MHS-60V-MST	79449
1800	72	MHS-72V-MST	79450

*V-Tips can be used ONLY on vulcanized belts

MHS with PAT*

Belt Width	Ordering	Item	
mm	in.	Number	Code
600	24	MHS-24P	78736
750	30	MHS-30P	78737
900	36	MHS-36P	78738
1050	42	MHS-42P	78739
1200	48	MHS-48P	78740
1350	54	MHS-54P	78741
1500	60	MHS-60P**	78742
1800	72	MHS-72P**	78743
2100	84	MHS-84P**	78744
2400	96	MHS-96P**	79047

*Includes Control Box
**60", 72" and 96" models have a 3-piece pole.

MHS Reversing with C-Tips

Belt Width	Ordering	Item	
mm	in.	Number	Code
600	24	MHS600R	82973
750	30	MHS750R	82974
900	36	MHS900R	82975
1050	42	MHS1050R	82976
1200	48	MHS1200R	82977
1350	54	MHS1350R	82978
1500	60	MHS1500R	82979
1650	66	MHS1650R	82980
1800	72	MHS1800R	82981
1950	78	MHS1950R	82982
2100	84	MHS2100R	82983
2250	90	MHS2250R	82984
2400	96	MHS2400R	82985

MHS Reversing with V-Tips*

Belt Width	Ordering	Item	
mm	in.	Number	Code
450	18	MHS450RV	82986
600	24	MHS600RV	82987
750	30	MHS750RV	82988
900	36	MHS900RV	82989
1050	42	MHS1050RV	82990
1200	48	MHS1200RV	82991
1350	54	MHS1350RV	82992
1500	60	MHS1500RV	82993
1650	66	MHS1650RV	82994
1800	72	MHS1800RV	82995
1950	78	MHS1950RV	82996
2100	84	MHS2100RV	82997
2250	90	MHS2250RV	82998
2400	96	MHS2400RV	82999

*V-Tips can be used ONLY on vulcanized belts

Replacement Tips

Ordering	Item
Number	Code
ICT6	74535
RSA150	73628

Urethane Shields

Ordering	Item
Number	Code
UPFCC	79320

Tips Required Per Cleaner Size

mm	450	600	750	900	1050	1200	1350	1500	1800	2100	2400
in.	18	24	30	36	42	48	54	60	72	84	96
C-Tips or V-Tips Required	3	4	5	6	7	8	9	10	12	14	16

Authorized Distributor:

2 Woodlands Sector 1 • #01-21 • Woodlands Spectrum I • Singapore 738068
Tel: +65-6484-1533 • Fax: +65-6484-1531 • E-mail: asiasales@flexco.com

Visit www.flexco.com for other Flexco locations and products.

©2018 Flexible Steel Lacing Company. 02/07/18. For reorder: X5041

