

H-TYPE® Precleaner with V- or VP-Tips

High Efficiency Tungsten-Carbide Precleaner

The Flexco H-Type® Precleaner with V- or Protected V-Tips is designed to be positioned on the head pulley and to remove the bulk of the carryback from the belt. Proven performance over 20 years as the most efficient pre-cleaner in material handling applications such as coal, iron ore, bauxite and hard rock mining with vulcanized belts.

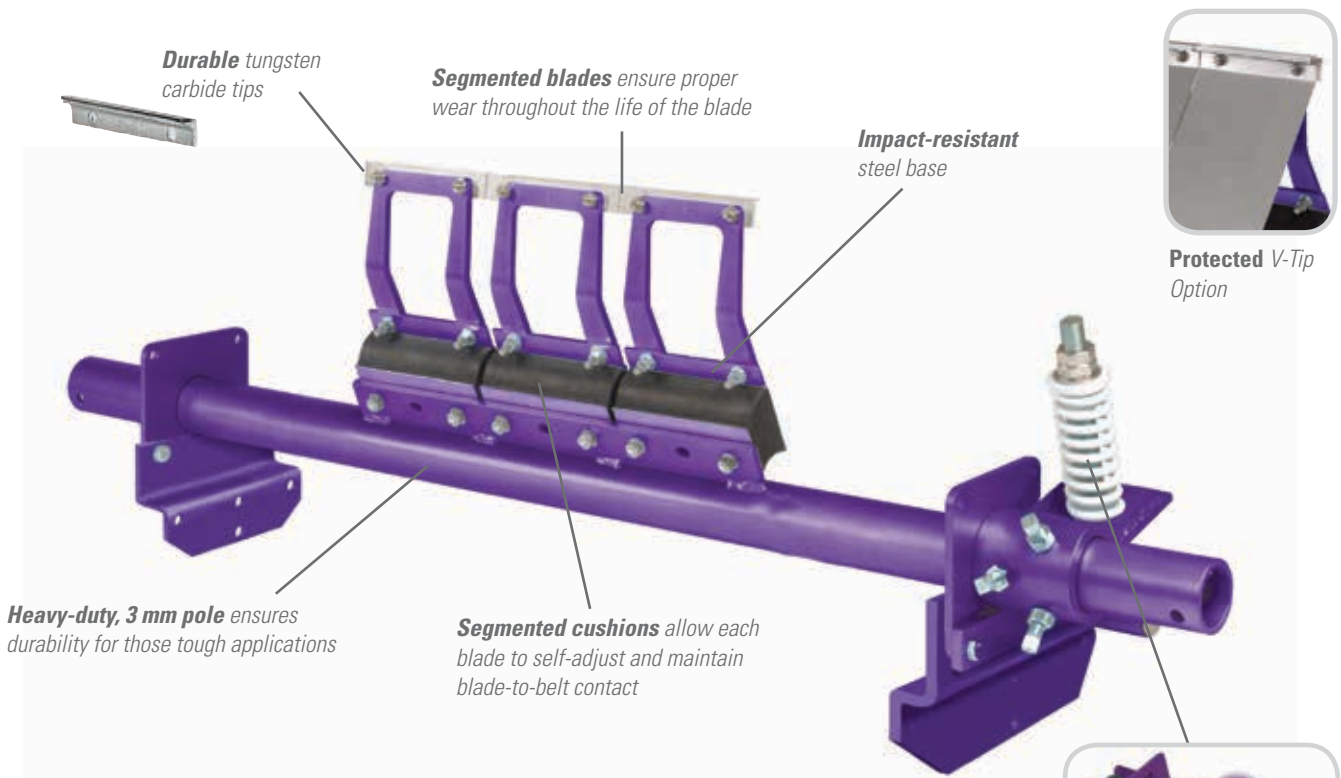

Features and Benefits

- **Works with vulcanized belts.** The tungsten carbide tips allow for maximum cleaning efficiency and superior wear characteristics. Also available with protected tips for abrasive applications.
- **Complete cleaning system.** When teamed with a secondary cleaner, it makes up a system that delivers maximum cleaning power for the most abusive conveyor applications.
- **Made for mining conveyors.** Made from heavy-duty steel with corrosion-resistant powder coating, the H-Type is available in sizes for belt widths from 450 to 1800mm (18" to 72"). Additional sizes are available upon request.
- **Optimal positioning.** Blade contact on the pulley is 15° below the horizontal centerline. This keeps the blades out of the discharge path and protects them from rocks, large lumps and other debris.



Quick Mount Tensioner (QMT)
allows the blade tension to be visually inspected

H-TYPE® Precleaner with V- or VP-Tips

Specifications and Guidelines

Maximum Belt Speed

5 m/s (1000 FPM)

Temperature Rating

-35° C to 82° C (-30° F to 180° F)

Minimum Pulley Diameter

250mm (10")

CEMA Cleaner Rating

Class 4

Usable Blade Wear Length

9mm (3/8")

Blade Material

Tungsten carbide (for vulcanized belts only)

Available for Belt Widths

450 to 1800mm (18" to 72")

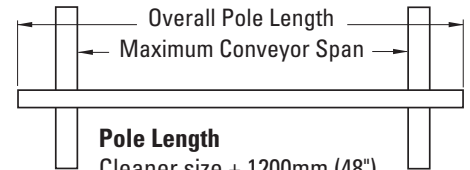

Pole Length

Cleaner size + 1200mm (48")

Maximum Conveyor Span

Cleaner size + 950mm (38")

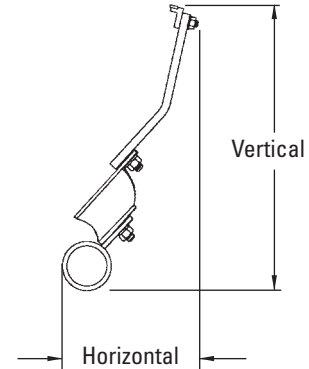

Horizontal Clearance Required
175mm (7")

Vertical Clearance Required

SS: 325mm (13")

S: 375mm (15")

M: 413mm (16-1/2")

L: 463mm (18-1/2")

LL: 550mm (22")

Ordering Information				
H-Type® with V-Tips*				
Belt Width	Suspension Arm Size	Ordering Number	Item Code	
mm	in.			
450	18	SS	HV450SS	81805
450	18	S	HV450S	81806
450	18	M	HV450M	81807
600	24	SS	HV600SS	81808
600	24	S	HV600S	81809
600	24	M	HV600M	81810
750	30	SS	HV750SS	81811
750	30	S	HV750S	81812
750	30	M	HV750M	81813
900	36	SS	HV900SS	81814
900	36	S	HV900S	81815
900	36	M	HV900M	81816
900	36	L	HV900L	81817
1050	42	SS	HV1050SS	81818
1050	42	S	HV1050S	81819
1050	42	M	HV1050M	81820
1050	42	L	HV1050L	81821
1050	42	LL	HV-42LL	76253
1200	48	SS	HV1200SS	81822
1200	48	S	HV1200S	81823
1200	48	M	HV1200M	81824
1200	48	L	HV1200L	81825
1200	48	LL	HV-48LL	76257
1350	54	S	HV-54S	76107
1350	54	M	HV1350M	81826
1350	54	L	HV1350L	81827
1350	54	LL	HV1350LL	81828
1500	60	S	HV-60S	76108
1500	60	M	HV1500M	81829
1500	60	L	HV1500L	81830
1500	60	LL	HV1500LL	81831
1600	64	M	HV1600M	81832
1600	64	L	HV1600L	81833
1600	64	LL	HV1600LL	81834
1800	72	S	HV-72S	76109
1800	72	M	HV1800M	81835
1800	72	L	HV1800L	81836
1800	72	LL	HV1800LL	81837

H-Type with Protected V-Tips*				
For abusive applications where materials being cleaned off the belt wear the back sides of the cleaner's V-Tips.				
Belt Width	Suspension Arm Size	Ordering Number	Item Code	
mm	in.			
450	18	S	HVP-18S	76124
450	18	M	HVP-18M	76267
450	18	L	HVP-18L	76268
600	24	S	HVP-24S	76125
600	24	M	HVP-24M	76269
600	24	L	HVP-24L	76270
750	30	S	HVP-30S	76126
750	30	M	HVP-30M	76271
750	30	L	HVP-30L	76272
900	36	S	HVP-36S	76127
900	36	M	HVP-36M	76273
900	36	L	HVP-36L	76274
1050	42	S	HVP-42S	76128
1050	42	M	HVP-42M	76275
1050	42	L	HVP-42L	76276
1200	48	S	HVP-48S	76129
1200	48	M	HVP-48M	76277
1200	48	L	HVP-48L	76278
1200	48	LL	HVP-48LL	76279
1350	54	S	HVP-54S	76130
1350	54	M	HVP-54M	76280
1350	54	L	HVP-54L	76281
1350	54	LL	HVP-54LL	76282
1500	60	S	HVP-60S	76131
1500	60	M	HVP-60M	76283
1500	60	L	HVP-60L	76284
1500	60	LL	HVP-60LL	76285
1800	72	S	HVP-72S	76132
1800	72	M	HVP-72M	76286
1800	72	L	HVP-72L	76287
1800	72	LL	HVP-72LL	76288

*NOTE: Protected V-Tips can be used ONLY on vulcanized belts. Suspension arm size is determined by head pulley diameter - see chart. Cleaners come standard with Stainless Steel Tip Shields. Additional sizes available upon request. Lead time: 1 working day

Suspension Arm Size		
Head Pulley Diameter + Belt & Lagging		Suspension Arm Size
mm	in.	
250-475	10 - 19	SS
500-775	20 - 31	S
800-975	32 - 39	M
1000-1175	40 - 47	L
1200-1675	48 - 67	LL

Replacement V-Tips	
Ordering Number	Item Code
HVT8-S/S	75419

Lead time: 1 working day

Replacement Protected V-Tips	
Ordering Number	Item Code
HVPT	73631

Lead time: 1 working day

Authorized Distributor:



2 Woodlands Sector 1 • #01-21 • Woodlands Spectrum | • Singapore 738068
Tel: +65-6484-1533 • Fax: +65-6484-1531 • E-mail: asiasales@flexco.com

Visit www.flexco.com for other Flexco locations and products.

©2018 Flexible Steel Lacing Company. 02/05/18. For reorder: X5039