

# Y-Type™ Polyurethane and Carbide Secondary Cleaner

## Simple, Effective Cleaning for Cement Operations Where Dust is Widespread

The Y-Type™ Secondary Cleaner should be installed throughout the cement process, especially in areas such as the materials storage and proportioning and finish mills, where dust is widespread. With easy, do-it-yourself installation and simple, serviceable blades, all at an affordable price, it makes for the ideal solution to facilitate the capture of usable materials.

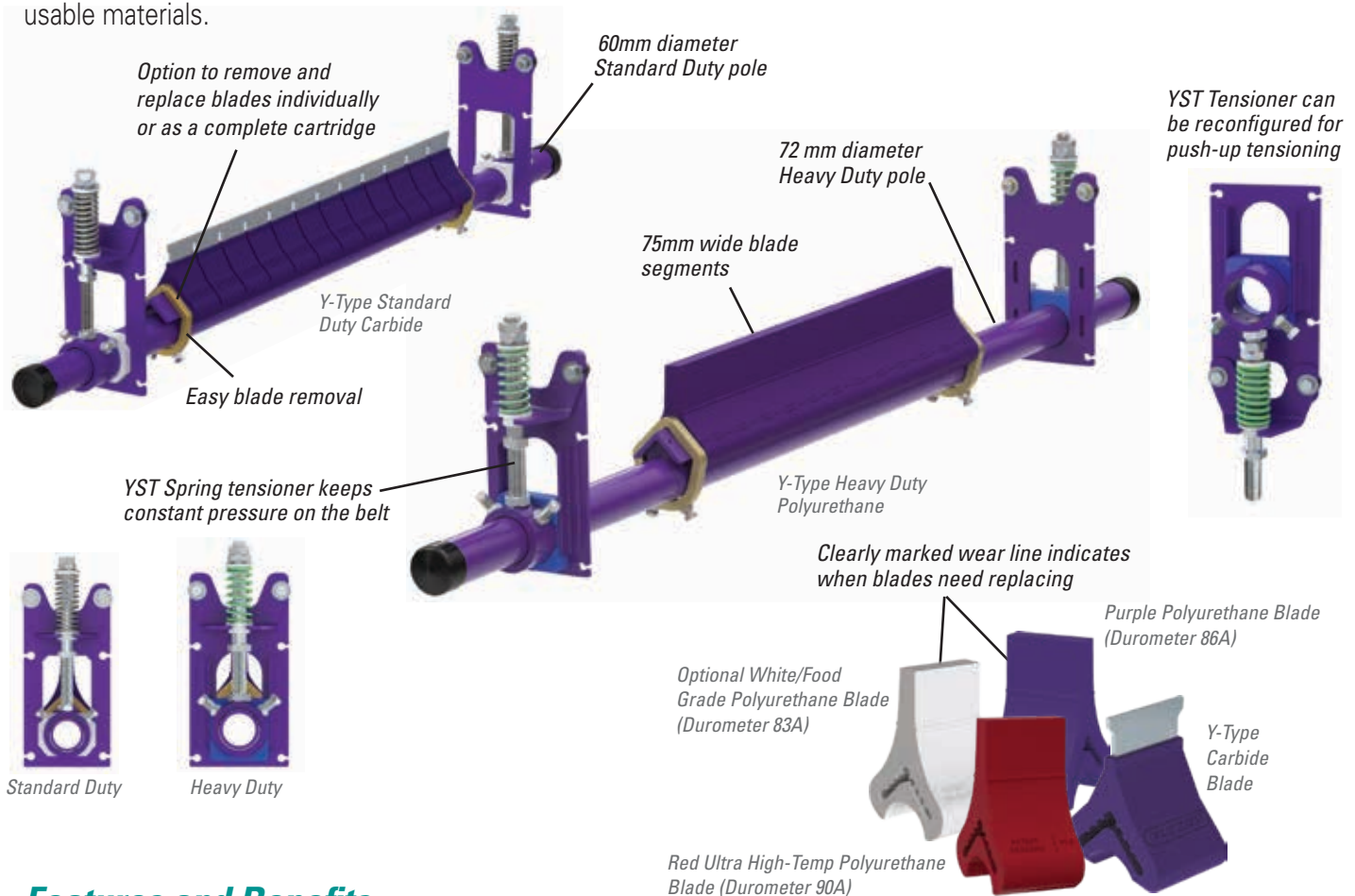

### Features and Benefits

- Belt speeds up to 3 m/s for standard duty, up to 3.8 m/s for heavy duty.
- Works on reversing belts.
- Available in 450 - 1200mm for standard duty belts, 900 - 1800mm for heavy duty belts .
- 75mm wide blade segments. Conforms to worn or damaged belts.
- Blades available in carbide and purple or white/food grade polyurethane.
- **Easy maintenance.** Simple design makes changing the blades fast and easy. Blades can be removed and replaced individually, or all at once by replacing the cartridge.
- **Spring tensioner.** Utilizes the YST tensioner to maintain constant pressure on the belt. Standard duty YST for 60mm poles, heavy duty YST for 73mm poles.

# Y-Type™ Polyurethane and Carbide Secondary Cleaner

## Specifications and Guidelines

	Standard Duty	Heavy Duty
Maximum Belt Speed	3 m/s	3.8 m/s
Temperature Rating	Purple, White, Carbide: -35° C to 82° C Red UHT: up to 200° C with spikes to 232° C	
Usable Blade Wear Length	Polyurethane: 50 mm	Polyurethane: 75 mm
	Carbide: 6 mm	Carbide: 10 mm
Available for Belt Widths	450 to 1200 mm	900 to 1800 mm

### Blade Material

Purple: Polyurethane (proprietary blend for abrasion resistance and long wear)

White: Polyurethane (chemical resistant/food grade)\*

Red: Polyurethane (ultra high-temp)

Carbide: Impact resistant tungsten carbide

\*All ingredients used in polyurethane formulation comply with the relevant requirements of 21 CFR (FDA Code of Federal Regulations) for use in repeated bulk dry food applications.

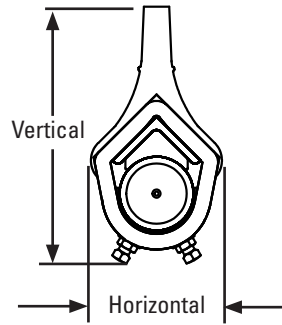

### Horizontal Clearance Required

**Standard Duty:** 110 mm

**Heavy Duty:** 135 mm

### Vertical Clearance Required

**Standard Duty:**

Polyurethane: 210 mm

Carbide: 185mm

**Heavy Duty:**

Polyurethane: 240 mm

Carbide: 250 mm

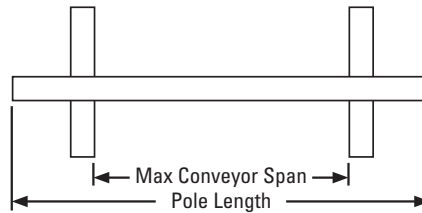

### Pole Length

SD Belt width + 762 mm

HD Belt width + 1372 mm

### Maximum Conveyor Span

SD Belt width + 559 mm

HD Belt width + 1169 mm

## Ordering Information

### Y-Type Secondary Cleaners - Standard Duty

Belt Width mm	Carbide Blades		Purple Polyurethane Blades		White/Food Grade Polyurethane Blades		Red/Ultra High-Temp Polyurethane Blades	
	Ordering Number	Item Code	Ordering Number	Item Code	Ordering Number	Item Code	Ordering Number	Item Code
450	YT-TC-18S	79759	YT-18S	79765	YTW-18S	79771	YTR-18S	91798
600	YT-TC-24S	79760	YT-24S	79766	YTW-24S	79772	YTR-24S	91799
750	YT-TC-30S	79761	YT-30S	79767	YTW-30S	79773	YTR-30S	91800
900	YT-TC-36S	79762	YT-36S	79768	YTW-36S	79774	YTR-36S	91801
1050	YT-TC-42S	79763	YT-42S	79769	YTW-42S	79775	YTR-42S	91802
1200	YT-TC-48S	79764	YT-48S	79770	YTW-48S	79776	YTR-48S	91803

Lead time: 1 working day

### Y-Type Secondary Cleaners - Heavy Duty

Belt Width mm	Carbide Blades		Purple Polyurethane Blades		White/Food Grade Polyurethane Blades		Red/Ultra High-Temp Polyurethane Blades	
	Ordering Number	Item Code	Ordering Number	Item Code	Ordering Number	Item Code	Ordering Number	Item Code
900	YTHD-TC-36S	79777	YTHD-36S	79783	YTHDW-36S	79789	YTHDR-36S	91816
1050	YTHD-TC-42S	79778	YTHD-42S	79784	YTHDW-42S	79790	YTHDR-42S	91817
1200	YTHD-TC-48S	79779	YTHD-48S	79785	YTHDW-48S	79791	YTHDR-48S	91818
1350	YTHD-TC-54S	79780	YTHD-54S	79786	YTHDW-54S	79792	YTHDR-54S	91819
1500	YTHD-TC-60S	79781	YTHD-60S	79787	YTHDW-60S	79793	YTHDR-60S	91820
1800	YTHD-TC-72S	79782	YTHD-72S	79788	YTHDW-72S	79794	YTHDR-72S	91821

Lead time: 1 working day

### Blades Required per Cleaner Size - Standard

mm	450	600	750	900	1050	1200
Blades Required	6	8	10	12	14	16

### Blades Required per Cleaner Size - HD

mm	900	1050	1200	1350	1500	1800
Blades Required	12	14	16	18	20	24

Authorised Distributor:

Flexco Europe GmbH • Maybachstrasse 9 • 72348 Rosenfeld • Germany  
Tel: +49-7428-9406-0 • Fax: +49-7428-9406-260 • E-mail: europe@flexco.com

Visit [www.flexco.com](http://www.flexco.com) for other Flexco locations and products.

©2020 Flexible Steel Lacing Company. 10/07/20. For reorder: X4912

