

# EZP1 Rockline® Standard-Duty Precleaner

## Simple, Quick, Effective Belt Cleaning for Cement Operations

The EZP1 Precleaner is not your average solid-blade belt cleaner that mounts on the head pulley. It features a unique single blade design that combines simple, do-it-yourself installation, quick maintenance, and effective cleaning results with a price tag that you can afford. Install the EZP1 anywhere throughout the process where dust is widespread to facilitate the capture of usable material and avoid potential safety citations for hazardous piles.

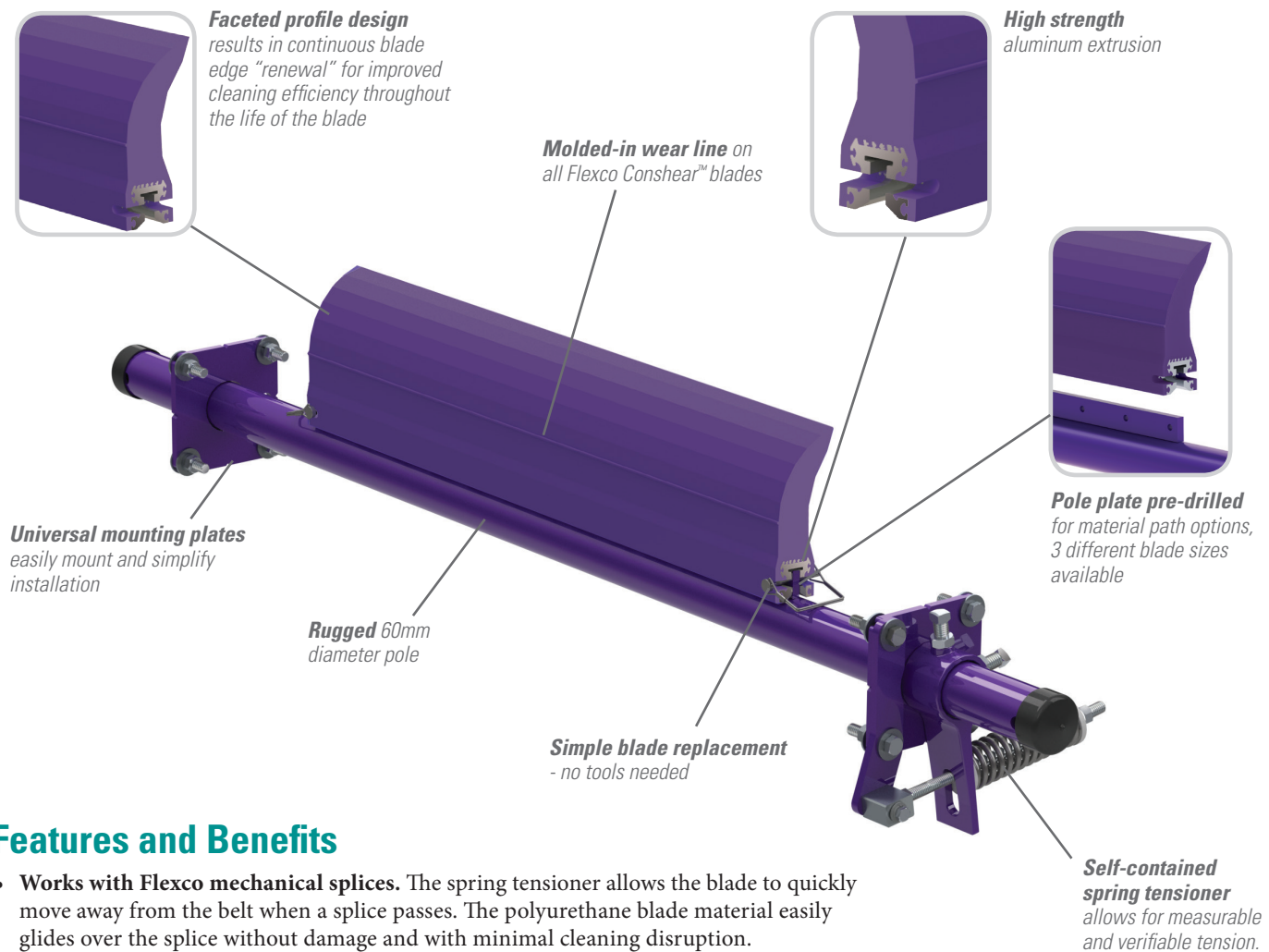

### Features and Benefits

- **Works with Flexco mechanical splices.** The spring tensioner allows the blade to quickly move away from the belt when a splice passes. The polyurethane blade material easily glides over the splice without damage and with minimal cleaning disruption.
- **Compact, streamlined design.** The EZP1 Precleaner requires only 100 mm of horizontal clearance for correct installation. Its streamlined contours prevent material buildup on the blade or the pole.
- **Can be used on reversing belts.** Installing cleaners on both pulleys gives superior cleaning results on belts that run in both directions.
- **Fits most conveyor structures.** Available for belt widths from 300 to 1800mm.
- **Blade can be used on other cleaners.** The ConShear™ blade can be used as a replacement blade on many OEM cleaners.

# EZP1

## Rockline® Standard-Duty Precleaner

### Specifications and Guidelines

- **Maximum Belt Speed**  
3.5 M/sec
- **Temperature Rating**  
-35°C to 82°C
- **Minimum Pulley Diameter**  
250mm
- **Blade Height**  
185mm
- **Usable Blade Wear Length**  
100mm
- **Blade Material**  
Polyurethane 83 durometer (proprietary blend for abrasion resistance and long wear)
- **CEMA Cleaner Rating**  
Class 3
- **Available for Belt Widths**  
300 to 1800mm
- **Horizontal Clearance Required**  
100mm
- **Vertical Clearance Required**  
238mm
- **Pole Length**  
Cleaner size up to 1200mm + 750mm  
Cleaner size over 1200mm + 850mm
- **Maximum Conveyor Span**  
Cleaner size up to 1200mm + 625mm  
Cleaner size over 1200mm + 725mm

#### Pole Location Specs

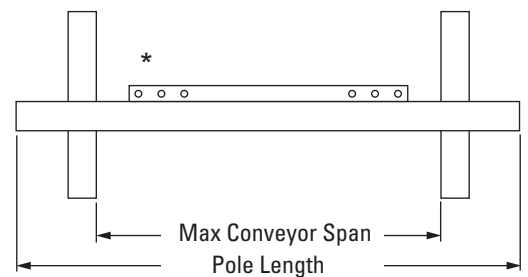
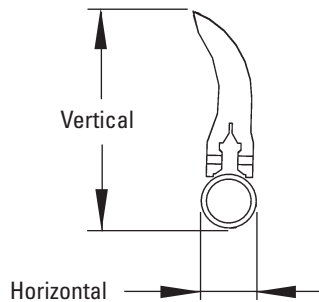
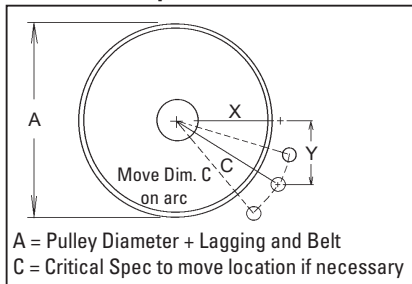

#### Pole Location Chart

A	X	Y	C	A	X	Y	C	A	X	Y	C
250	74	230	242	500	235	230	329	725	374	230	439
275	92	230	248	525	249	230	339	775	389	230	452
300	108	230	254	550	266	230	352	775	403	230	464
325	131	230	265	575	283	230	365	825	417	230	477
350	146	230	273	600	299	230	377	825	432	230	489
375	166	230	284	625	314	230	390	850	446	230	501
400	179	230	291	650	330	230	402	875	460	230	514
425	195	230	301	675	346	230	415	900	474	230	526
450	207	230	309	700	360	230	427				

### Ordering Information

EZP1 Precleaners - Belt Width - 50mm Blade			
Belt Width	Blade Coverage	Ordering Number	Item Code
mm	mm		
300	250	EZP1-212	75610
450	400	EZP1-218	75611
600	550	EZP1-224	75612
750	700	EZP1-230	75613
900	850	EZP1-236	75614
1050	1000	EZP1-242	75615
1200	1150	EZP1-248	75616
1350	1300	EZP1-254	75617
1500	1450	EZP1-260	75618
1800	1750	EZP1-272	75771

EZP1 Precleaners - Belt Width - 200mm Blade			
Belt Width	Blade Coverage	Ordering Number	Item Code
mm	mm		
300	-	N/A	N/A
450	250	EZP1-818	75779
600	400	EZP1-824	75780
750	550	EZP1-830	75781
900	700	EZP1-836	75782
1050	850	EZP1-842	75783
1200	1000	EZP1-848	75784
1350	1150	EZP1-854	75785
1500	1300	EZP1-860	75786
1800	1600	EZP1-872	75774

ConShear™ Replacement Blades		
Blade Width	Ordering Number	Item Code
mm		
250	CRB10	75628
400	CRB16	75629
550	CRB22	75630
700	CRB28	75631
850	CRB34	75632
1000	CRB40	75633
1150	CRB46	75634
1300	CRB52	75635
1450	CRB58	75636
1600	CRB64	75775
1750	CRB70	75773

Authorised Distributor: