

MMP Medium-Duty Precleaner

Extra Cleaning Power for Quarry Belts

In the quarry and at the primary crusher and stockpiles, where wider belts travel at faster speeds, you need a cleaner that can withstand the abuse caused by larger materials. The MMP Medium-Duty Precleaner tackles those tough applications where the standard-duty precleaner is not sturdy enough but the heavy-duty cleaner is overkill. The MMP is built tough with a heavy-duty pole, a larger, powerful blade and a beefy dual tensioning system. Yet installation is simple, maintenance is quick, and bottom line—the cleaning job is excellent.

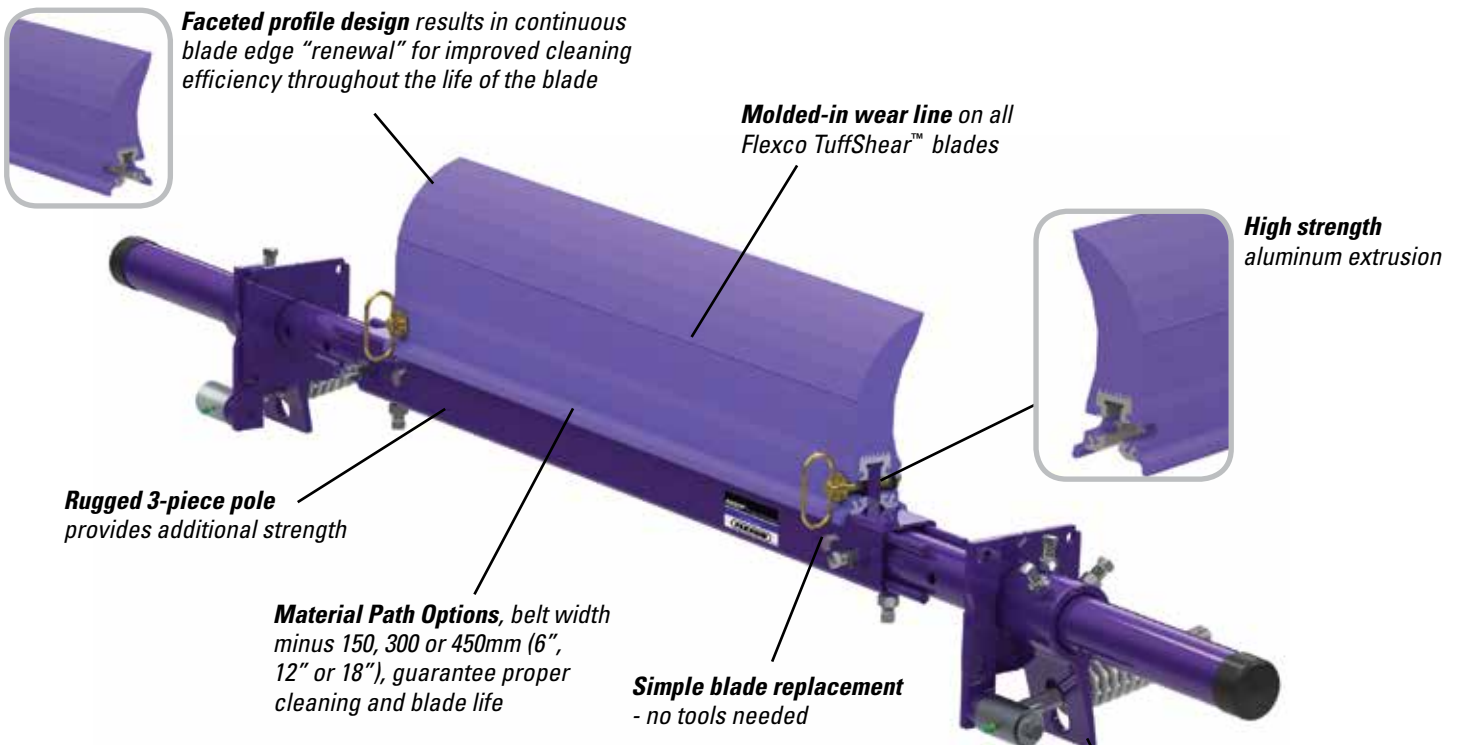

Features and Benefits

- **Compact and versatile.** Requires only 100 mm (4") of horizontal clearance for installation. Pole length is belt width plus 1350mm (54") to fit varying conveyor or chute wall widths. Pole extenders are available for extended length requirements.
- **Works with Flexco and other mechanical splices.** The spring tensioner quickly moves the blade away from the belt when a splice passes. The polyurethane blade easily glides over the splice without damage and with minimal cleaning disruption.
- **Made for mining conveyors.** Made from heavy-duty steel with corrosion-resistant powder coating, the MMP is available for belt widths from 600 to 2400 mm (24" to 96"). Special sizes are available upon request.
- **Complete cleaning system.** When teamed with our MHS Secondary Cleaner, it makes up a system that delivers maximum cleaning power. If extra water is present, the MDWS DryWipe can be added.

MMP Medium-Duty Precleaner

Specifications and Guidelines

- **Maximum Belt Speed**
5M/Sec (1000 FPM)
- **Temperature Rating**
-35°C to 82°C (-30°F to 180°F)
- **Minimum Pulley Diameter**
400mm (16")
- **Blade Height**
250mm (10")
- **Usable Blade Wear Length**
150mm (6")
- **Blade Material**
Polyurethane 83 durometer (proprietary blend for abrasion resistance and long wear)
- **Available for Belt Widths**
600 to 2100mm (24" to 84")
- **Horizontal Clearance Required**
100mm (4")
- **Vertical Clearance Required**
325mm (13")
- **CEMA Cleaner Rating**
Class 4
- **Pole Length**
Cleaner size + 1350mm (54")
- **Maximum Conveyor Span**
Cleaner size 1050mm (42")

Pole Location Specs

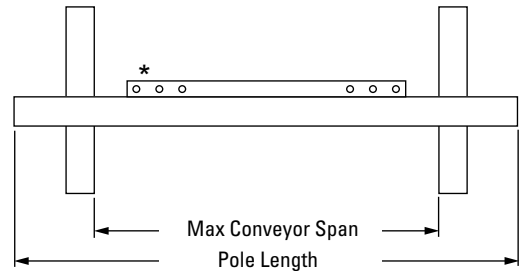
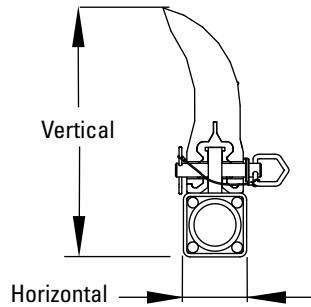
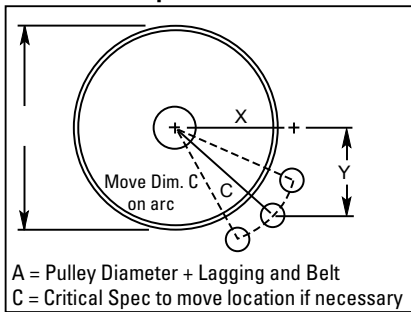

Pole Location Chart

A	X	Y	C	A	X	Y	C	A	X	Y	C
400	206	305	368	675	359	305	470	950	502	305	587
425	222	305	378	700	371	305	479	975	518	305	600
450	235	305	384	725	387	305	492	1000	527	305	610
475	248	305	394	750	397	305	502	1025	543	305	622
500	264	305	403	775	410	305	511	1050	552	305	632
525	279	305	413	800	425	305	524	1075	568	305	645
550	292	305	422	825	438	305	533	1100	578	305	654
575	305	305	432	850	451	305	543	1125	594	305	667
600	321	305	441	875	464	305	556	1150	606	305	679
625	333	305	451	900	476	305	565	1175	619	305	689
650	346	305	460	925	492	305	578	1200	632	305	702

Ordering Information

MMP Precleaner - Belt Width Minus 6"					
Belt Width		Blade Width		Ordering Number	Item Code
mm	in.	mm	in.		
600	24	450	18	MMP-624	76450
750	30	600	24	MMP-630	76451
900	36	750	30	MMP-636	76452
1050	42	900	36	MMP-642	76453
1200	48	1050	42	MMP-648	76454
1350	54	1200	48	MMP-654	76455
1500	60	1350	54	MMP-660	76456
1800	72	1650	66	MMP-672	76457
2100	84	1950	78	MMP-684	76798
2400	96	2250	90	MMP-696	79033

MMP Precleaner - Belt Width Minus 12"

Belt Width		Blade Width		Ordering Number	Item Code
mm	in.	mm	in.		
750	30	450	18	MMP-1230	76551
900	36	600	24	MMP-1236	76552
1050	42	750	30	MMP-1242	76553
1200	48	900	36	MMP-1248	76554
1350	54	1050	42	MMP-1254	76555
1500	60	1200	48	MMP-1260	76556
1800	72	1500	60	MMP-1272	76557
2100	84	1800	72	MMP-1284	76799
2400	96	2100	84	MMP-1296	79034

TuffShear™ Replacement Blades

Blade Width		Ordering Number	Item Code
in.	mm		
450	18	TRB18	76485
600	24	TRB24	76486
750	30	TRB30	76487
900	36	TRB36	76488
1050	42	TRB42	76489
1200	48	TRB48	76490
1350	54	TRB54	76491
1500	60	TRB60	76492
1650	66	TRB66	76493
1800	72	TRB72	76494
1950	78	TRB78	76697
2100	84	TRB84	77047
2250	90	TRB90	77048

Other blade sizes available upon request.

Authorized Distributor: