



Product Guide

EFFECTIVE JULY 1, 2017

BCPPGAUS

Belt Conveyor Products



10 Solent Circuit
Baulkham Hills NSW 2153

Phone: +61 2-8818-2000 Fax: +61 2-8824-6333

Toll Free: 1300 098 435

E-mail: salesau@flexco.com

www.flexco.com

INFORMATION

HEAD OFFICE ADDRESS: Flexco® (Aust.) Pty Ltd
10 Solent Circuit
Baulkham Hills, NSW 2153

OFFICE TELEPHONE: +61 2 8818-2000

WESTERN AUSTRALIA OFFICE ADDRESS: Unit 1/13 Ernest Clark Rd.
Canning Vale, WA 6155
Phone: 08 9456 2521
Fax: 08 9456 2571

BUNDABERG OFFICE ADDRESS: 49 Hanbury Street, Bundaberg, QLD
4670 Australia
Ph: 07 4151-0359
F: 07 4151-0568

POSTAL ADDRESS: P.O. Box 6365
Baulkham Hills B.C. NSW 2153

EMAIL: salesau@flexco.com
marketingau@flexco.com

OFFICE FACSIMILE: +612 8824-6333

TERMS AND CONDITIONS: Prices are in AUD exclusive of GST.

1. Stock items (non-shaded) please refer to asterisk (*) for specific lead time, if not specified, standard 2-3 days lead-time applies.
2. Some assembled items and larger quantities may take longer, please contact Flexco for specifics.
3. Non-stock items (shaded) please contact Flexco for dispatch options and lead times.
4. Minimum order size for free shipping is \$4,000.00 net.
5. Strictly Net 30 days unless otherwise negotiated.
6. 3rd party deliveries may be refused—please contact customer service.
7. Flexco endeavours to hold adequate stock levels at all times, however fluctuations do occur; stock is subject to availability.

LIMITED LIABILITY: Every effort is made to ensure the information contained in this price book is accurate and in accordance with all current specifications, however the company cannot be held responsible for any errors and reserves the right, without prior notice, to change specifications, quantities, and prices.

Visit our Web site at: www.flexco.com

Table of Contents

Belt Cleaners

Belt Cleaner Information and Selection Guide 5

Primary Cleaners

EZP-LS Limited Space Primary Cleaner	10
EZP1 Primary Cleaner & ConShear™ Replacement Blades	15
EZP1T Twist Tensioner Primary Cleaner	20
Spring Covers and Tensioner Lock	22
MMP Medium-Duty Primary Cleaner & TuffShear™ Replacement Blades	23
Line Connections for Portable Air Tensioner	29
MHCP Heavy-Duty Cartridge Primary Cleaner & SuperShear™ Replacement Blades	30
H-Type® Primary Cleaners.....	36
H-Type® ESAC Heavy-Duty Primary Cleaner.....	43
H-Type® ESAC with Extra Life -V-Tips Heavy-Duty Primary Cleaner.....	49

Secondary Cleaners

Y-Type® Secondary Cleaners.....	56
P-Type® Secondary Cleaners	63
R-Type® Reversing Secondary Cleaners	65
MHS Heavy-Duty Secondary Cleaners.....	67
Spring Covers and Tensioner Lock	76
Cartridge Cleaners:	
P-Type Secondary Cleaners with Service Advantage Cartridge™.....	77
R-Type Secondary Cleaners with Service Advantage Cartridge.....	84
MHS Heavy-Duty Secondary Cleaners with Service Advantage Cartridge	91
Spring Covers and Tensioner Lock	104
U-Type® Secondary Cleaners	105
Motorised Brush Cleaner	111
Chevron Belt Cleaner	114
Wash Box.....	115

Belt Cleaner Accessories

Inspection Doors.....	116
Spray Pole Systems.....	118
Mandrel Safety Removal System	120
Live Shaft Hold Down Rollers	121
Standard Pulley Lifter.....	122
Belt Cleaner Accessories.....	123
Optional Mounting Kits	124

Impact Beds

Flexco® Slider and Impact Beds

EZSB-C and EZSB-I Slider Beds; EZIB-L and EZIB-M Impact Beds	126
--	-----

DRX® Impact Beds

DRX200 - DRX1500 Impact Beds.....	135
DRX3000 Dynamic Bed.....	138
Optional Parts and Tools.....	139

Belt Conveyor Products

Ploughs

V-Plough.....	140
Twin Pole V-Plough.....	141
HD® Floating V-Plough	143
Diagonal Plough	145
HD Spring-Tensioned Diagonal Plough.....	146

Table of Contents

Belt Positioners and Trainers

Belt Positioner™	147
PTEZ	149
PT Smart™ Belt Trainer	151
PT Pro.....	154
PT Max™ Belt Trainer	157

Skirting Systems

Skirt Clamps-RMC1, Flex-Lok™, and FlexSeal™	160
Standard Urethane Skirting	161

Belt Maintenance Tools

Flex-Lifter™	162
Electric and Pneumatic Belt Cutters	162

Index	163
--------------------	------------

Belt Cleaner Information and Selection Guide

Why Are Belt Cleaners Needed?

- **Reduces Maintenance Costs**
 - Minimises manual cleanup.
 - Protects against belt mistracking.
 - Reduces conveyor component replacement costs.
 - Reducing carryback means a reduction in maintenance costs.
- **Improves Safety**
 - Reduces housekeeping problems.
 - A majority of conveyor-related accidents happen while maintenance tasks are being done.
- **Keeps Conveyors Running Efficiently and Consistently**
 - Reduces unscheduled downtime.
 - Increases production uptime.
- **Saves Money**
 - Increases belt wear life.
 - Extends life of rollers, pulleys and splices.
 - High cost of accidents.



Types of Belt Cleaners

- **Primary Cleaners**
 - Mounted on the head pulley.
 - Mounted below the material flow.
 - Removes the big stuff. Typically cleans off up to 80% of the initial carryback.
- **Secondary Cleaners**
 - Located just past where the belt leaves the head pulley and anywhere down the beltline.
 - Special secondaries may allow for mounting under the head pulley.
 - Removes sticky fines – the final cleaning job.
 - May require a hold-down roller for maximum performance.
- **Specialty Cleaners**
 - Primary Cleaners or Secondaries designed especially for specific or extreme applications.

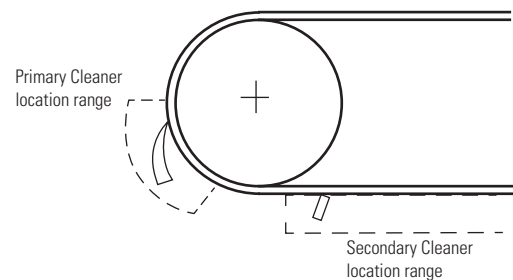

Definition of Terms

- **Carryback**—Material that sticks to the belt after it leaves the transfer point and continues falling off along the conveyor's return side.
- **Material Path**—The section of the belt where most of the material is conveyed. Typically the center 2/3 of the belt.
- **Hold-Down Roller**—A stabilising roller or pressure roller located on top of the return side of the belt to prevent belt flap or to provide a consistent flat surface for the blades on a lighter-tensioned belt.

Types of Cleaner Blades

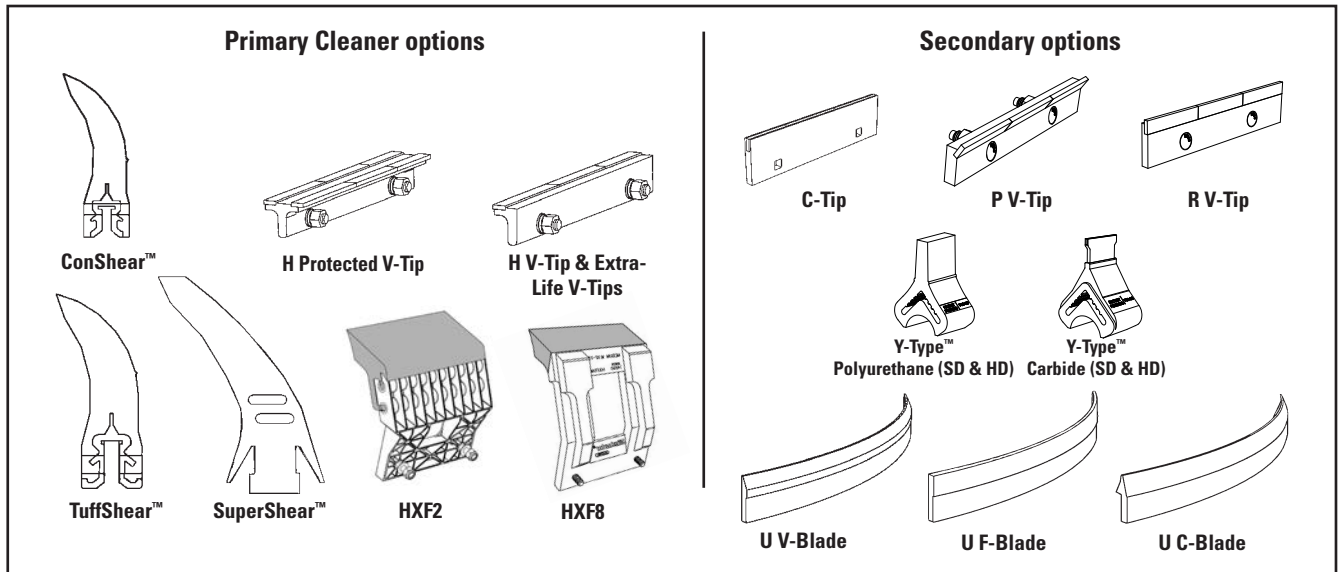

F-Tip/Blade - for mechanically fastened belts **V-Tip/Blade** - for vulcanised belts only **C-Tip/Blade** - for both

Polyurethane Blades

Not all polyurethanes are the same. Flexco's polyurethane blades are specially formulated for abrasion resistance and long wear. Independent testing has shown that Flexco's polyurethane blades last as much as 30% longer than other OEM blades.

- Easy on the belt.
- Work well with mechanical splices.
- Economical.
- Specialty formulations for high heat, chemical resistance, or water removal.
- FRAS for underground applications.



Less advanced polyurethane formulations result in blades that experience quicker wear and provide less-efficient cleaning.

Tungsten Carbide

Excellent for superior cleaning efficiency and long wear. The quality and application of carbides can vary. Flexco® has invested years of research and testing to develop tungsten carbide tips for both vulcanised and mechanically fastened belts. And a quality process ensures consistent results.

- Superior cleaning.
- Long wear.
- C-Tips/blades for mechanical splices and V-Tips/blades for vulcanised belts.

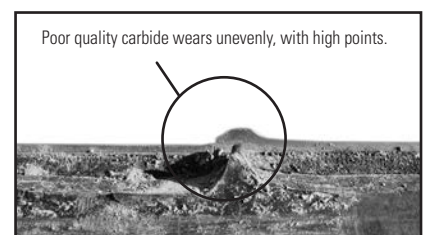

Poor quality carbide wears unevenly, with high points.

Blade Angle (Secondary cleaners)

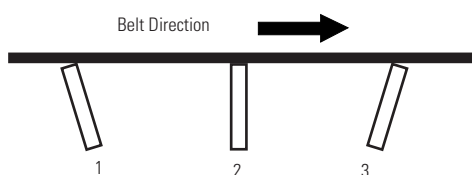

1. Aggressive - excellent cleanability, high risk for belt damage.
2. 90° to belt - good cleaning efficiency; must have good blade relief for splices (Flexco recommended).
3. Wiping - a little less cleaning power; safer on belts in poor condition or with poor mechanical splices.

Belt Cleaning Systems

Keys to Good Belt Cleaning

- Proper cleaner selection for the application
- Correct installation
- Regular service maintenance

Spec'ing and Ordering Belt Cleaners

Information needed:

- A.** Belt Width
- B.** Conveyor frame (structure) width
- C.** Head pulley diameter
- D.** For Primary Cleaners - what is the belt's material path
- E.** Material conveyed (dry, wet, sticky, etc.)
- F.** Type of belt splice:
 - Mechanical - skived or unskived
 - Vulcanised
- G.** Temperature or other extreme environmental factors
- H.** Does the belt reverse

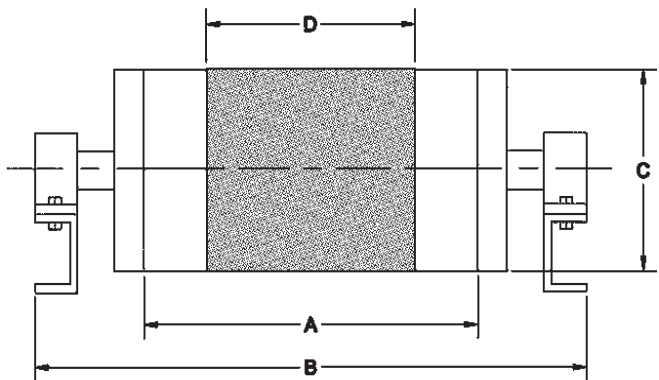

Primary Cleaner Selection Guide









Primary Cleaner Specification Chart

APPLICATION DESCRIPTION	EZP-LS	EZP1, HIGH TEMP EZP1	MMP	MHP	MHCP	H-TYPE® (HFX2, XF, XF8)	H-TYPE® (V)
Belt Width*	300 - 1500 mm	300 - 1800 mm	600 - 2100 mm	600 - 2400 mm	600 - 2100 mm	450 - 3200 mm	450 - 3200 mm
Head Pulley Diameter	150 - 550 mm	250 - 900 mm	400 - 1200 mm	500 - 1200 mm	500 - 1200 mm	250 - 1325 mm	250 - 1575 mm
Reversing Belts	Yes	Yes	Yes	Yes	Yes	Yes	Yes
Mechanical Fasteners	Yes	Yes	Yes	Yes	Yes	Yes	No





*Special sizes available upon request.

Contact Flexco® for pulleys over 1700 mm diameter.

Primary Cleaner Blade Specifications

									
Blade Type	ConShear™ LS	ConShear™ LS High Temp	ConShear™ LS White (Chemical Resistant/Food Grade) ‡	ConShear™	ConShear™ High Temp	ConShear™ White (Chemical Resistant/Food Grade) ‡	TuffShear™	MegaShear™	SuperShear™
Temperature Range	-30 to 180°F (-35 to 82°C)	up to 275°F (135°C) with spikes to 325°F (163°C)	-30 to 180°F (-35 to 82°C)	-30 to 180°F (-35 to 82°C)	up to 275°F (135°C) with spikes to 325°F (163°C)	-30 to 180°F (-35 to 82°C)	-30 to 180°F (-35 to 82°C)	-30 to 180°F (-35 to 82°C)	-30 to 180°F (-35 to 82°C)
Polyurethane	Yes	Yes	Yes	Yes	Yes	Yes	Yes	Yes	Yes
Durometer	83	93	83	83	93	83	83	90	90
Tungsten Carbide	No	No	No	No	No	No	No	No	No
Work with Mechanical Fasteners	Yes	Yes	Yes	Yes	Yes	Yes	Yes	Yes	Yes
FRAS	Contact Flexco								

Primary Cleaner Blade Specifications (cont.)

					
BLADE TYPE	HXF	HXF2	H V-TIP	H PROTECTED V-TIP	Extra Life V-Tips
Temperature Range	-35 to 82°C	-35 to 82°C	-35 to 205°C	-35 to 205°C	-35 to 205°C
Polyurethane	Yes	Yes	No	No	No
Durometer	84	83	N/A	N/A	N/A
Tungsten Carbide	No	No	Yes	Yes	Yes
Work with Mechanical Fasteners	Yes	Yes	No	No	No
FRAS	Yes	No	N/A	N/A	N/A

For Belt Speed information please consult your Flexco® representative

Secondary Cleaner Selection Guide

Secondary Cleaner Specification Chart

APPLICATION DESCRIPTION	MHS (C-TIP)	MHS (V-TIP)	P-TYPE® (C-TIP)	P-TYPE (V-TIP)	P-TYPE-LS (C-TIP)	Y-Type SD Polyurethane	Y-Type SD Carbide	Y-Type HD Polyurethane	Y-Type HD Carbide
Belt Width*	600-3000mm	600-3000mm	450-3000mm	450-3000mm	450-3000mm	450-1200mm	450-1200mm	900-1800mm	900-1800mm
Secondary Cleaner Blade Options	Yes	Yes	No	No	No	Yes	Yes	Yes	Yes
Work with Mechanical Fasteners	Yes	No	Yes	No	Yes	Yes	Yes	Yes	Yes

*Special sizes available upon request.
Contact Flexco® for belt widths over 3000 mm diameter.

Secondary Cleaner Specification Chart (cont.)

APPLICATION DESCRIPTION	U-TYPE® (F-BLADE)	U-TYPE (C-BLADE)	U-TYPE (V-BLADE)	R-TYPE® (C-TIP)	R-TYPE (V-TIP)	CHEVRON	Brush Cleaner
Belt Width*	450-3000mm	450-3000mm	450-3000mm	450-3000 mm	450-3000 mm	450-1500mm	450-2100 mm
Secondary Cleaner Blade Options	No	No	No	Yes	Yes	Yes	Yes
Work with Mechanical Fasteners	Yes	Yes	No	Yes	No	Yes	Yes

*Special sizes available upon request.
Contact Flexco for belt widths over 3000 mm diameter.

Secondary Cleaner Blade Specifications

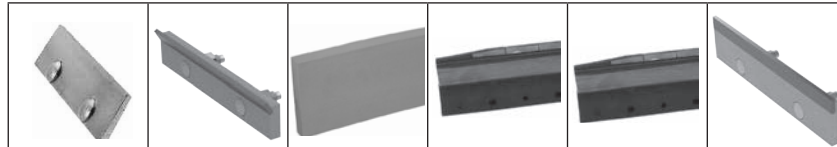

BLADE TYPE	C-TIP	P V-TIP	U F-BLADE	U C-BLADE	U V-BLADE	R V-TIP
Temperature Range	-35 to 205°C	-35 to 205°C	-35 to 82°C	-35 to 82°C	-35 to 82°C	-35 to 205°C
Polyurethane	No	No	Yes	Rubber	Rubber	No
Durometer	N/A	N/A	90	84	83	N/A
Tungsten Carbide	Yes	Yes	No	Yes	Yes	Yes
Work with Mechanical Fasteners	Yes	No	Yes	Yes	No	No

Secondary Cleaner Blade Specifications cont.

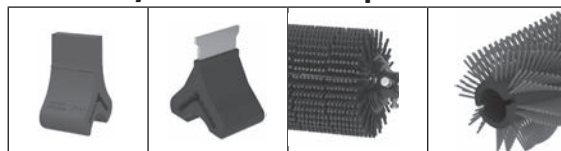

BLADE TYPE	Y-Type Polyurethane	Y-Type Carbide	Chevron	Brush Cleaner
Temperature Range	-35 to 82°C	-35 to 82°C	-35 to 82°C	-30 to 82°C
Polyurethane	Yes	No	Rubber	Polypropylene
Durometer	86A	N/A	N/A	N/A
Tungsten Carbide	YNo	Yes	No	No
Work with Mechanical Fasteners	Yes	Yes	Yes	Yes

For Belt Speed information please consult your Flexco® representative

Product Ordering Information

EZP-LS Limited Space Primary Cleaner and Stainless Steel Limited Space Primary Cleaner



EZP-LS Primary Cleaner Belt Width Minus 50mm

BELT WIDTH mm	BLADE COVERAGE mm	ORDERING NUMBER	ITEM CODE	WT. KG.
300	250	EZP-LS212	77127	11.3
450	400	EZP-LS218	77128	12.8
600	550	EZP-LS224	77129	14.4
750	700	EZP-LS230	77130	16.0
900	850	EZP-LS236	77131	17.6
1050	1000	EZP-LS242	77132	19.1
1200	1150	EZP-LS248	77133	20.7
1350	1300	EZP-LS254	77134	22.2
1500	1450	EZP-LS260	77135	23.9

EZP-LS High-Temp Primary Cleaner Belt Width Minus 2" (50mm)

BELT WIDTH		BLADE WIDTH		ORDERING NUMBER	ITEM CODE	WT. KG.
in.	mm	in.	mm			
12	300	10	250	EZP-LS212HT	77746	24.8
18	450	16	400	EZP-LS218HT	77747	28.2
24	600	22	550	EZP-LS224HT	77748	31.7
30	750	28	700	EZP-LS230HT	77749	35.1
36	900	34	850	EZP-LS236HT	77750	38.6
42	1050	40	1000	EZP-LS242HT	77751	42.0
48	1200	46	1150	EZP-LS248HT	77752	45.5
54	1350	52	1300	EZP-LS254HT	77753	48.9
60	1500	58	1450	EZP-LS260HT	77754	52.5

Stock items (non-shaded) refer to (*) for specific lead time, if not specified, standard lead time applies.

Non-stock items (shaded) please contact Flexco for dispatch options and lead times.

U.S. Patent No. D482,508S (blade)
Patent Pending (tensioner)

EZP-LS Stainless Steel Primary Cleaner Belt Width Minus 50mm (2")

BELT WIDTH mm	BLADE COVERAGE mm	ORDERING NUMBER	ITEM CODE	WT. KG.
300	250	EZP-LS212-S/S	62836	11.3
450	400	EZP-LS218-S/S	62837	12.8
600	550	EZP-LS224-S/S	62838	14.4
750	700	EZP-LS230-S/S	62839	16.0
900	850	EZP-LS236-S/S	62840	17.6
1050	1000	EZP-LS242-S/S	62841	19.1
1200	1150	EZP-LS248-S/S	62842	20.7
1350	1300	EZP-LS254-S/S	62843	22.2
1500	1450	EZP-LS260-S/S	62844	23.9

Lead time: 3 weeks

EZP-LS Stainless Steel High-Temp Primary Cleaner Belt Width Minus 50mm (2")

BELT WIDTH mm	BLADE COVERAGE mm	ORDERING NUMBER	ITEM CODE	WT. KG.
300	250	EZP-LS212HT-S/S	62845	11.3
450	400	EZP-LS218HT-S/S	62846	12.8
600	550	EZP-LS224HT-S/S	62847	14.4
750	700	EZP-LS230HT-S/S	62848	16.0
900	850	EZP-LS236HT-S/S	62849	17.6
1050	1000	EZP-LS242HT-S/S	62850	19.1
1200	1150	EZP-LS248HT-S/S	62851	20.7
1350	1300	EZP-LS254HT-S/S	62852	22.2
1500	1450	EZP-LS260HT-S/S	62853	23.9

Lead time: 3 weeks

EZP-LS Stainless Steel Primary Cleaner with White ConShear LS Blade Belt Width Minus 50mm (2")

BELT WIDTH mm	BLADE COVERAGE mm	ORDERING NUMBER	ITEM CODE	WT. KG.
300	250	CLSFG-212	77144	11.3
450	400	CLSFG-218	77145	12.8
600	550	CLSFG-224	77146	14.4
750	700	CLSFG-230	77147	16
900	850	CLSFG-236	77148	17.5
1050	1000	CLSFG-242	77149	19.1
1200	1150	CLSFG-248	77150	20.7
1350	1300	CLSFG-254	77151	22.2
1500	1450	CLSFG-260	77152	23.9

Specifications & Guidelines

EZP-LS Limited Space Primary Cleaner

Pole Length Specifications*

CLEANER SIZE mm	POLE LENGTH mm	MAXIMUM CONVEYOR SPAN mm
300	1050	925
450	1200	1075
600	1350	1225
750	1500	1375
900	1650	1525
1050	1800	1675
1200	1950	1825
1350	2200	2075
1500	2350	2225
1800	2650	2525

Pole Diameter - 48 mm

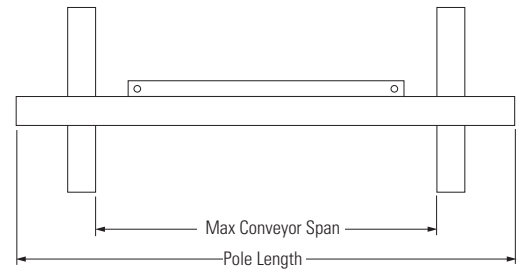

Clearance Guidelines for Installation

HORIZONTAL CLEARANCE REQUIRED mm	VERTICAL CLEARANCE REQUIRED mm
75	165

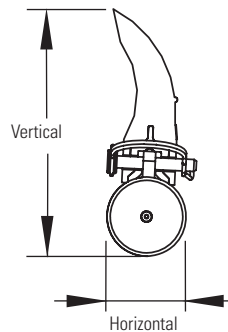

Pole Location Specs

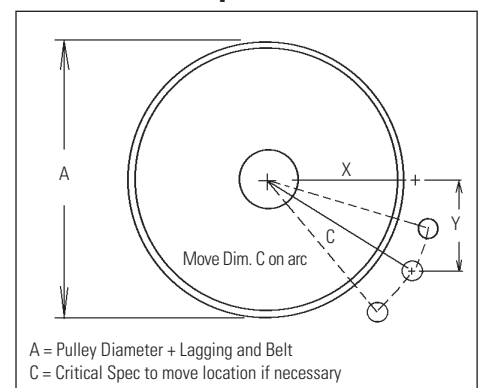

Spring Length Chart with LST Spring Tensioner

BLADE WIDTH mm	PURPLE SPRING mm	SILVER SPRING mm	BLACK SPRING mm
254	51	N/A	N/A
406	41	54	N/A
559	N/A	51	N/A
711	N/A	48	N/A
864	N/A	44	N/A
1016	N/A	38	N/A
1168	N/A	35	51
1321	N/A	N/A	51
1473	N/A	N/A	48

Shading indicates preferred spring option

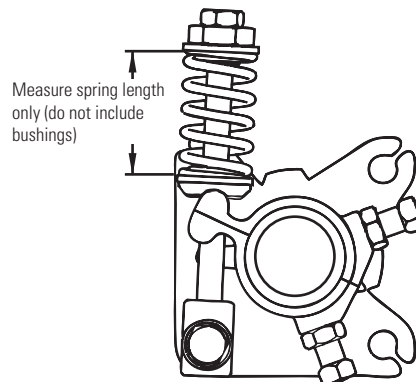

Pole Location Chart

A	X	Y	C
152	67	140	156
178	83	140	162
203	99	140	171
229	111	140	178
254	127	140	187
279	140	140	197
305	156	140	210
330	168	140	219
356	181	140	229
381	194	140	238
406	210	140	251
432	222	140	264
457	235	140	273
483	248	140	286
508	260	140	295
533	273	140	308
559	286	140	318

Specifications:

- Maximum Belt SpeedContact Flexco®
- Temperature Rating-35°C to 82°C
- Minimum Pulley Diameter.....150 mm
- Blade Height.....115 mm
- Usable Blade Wear Length.....60 mm
- BladePolyurethane (proprietary blend for abrasion resistance and long wear)
- Available for Belt Widths300 to 1800 mm

Replacement Parts List

EZP-LS Limited Space Primary Cleaner

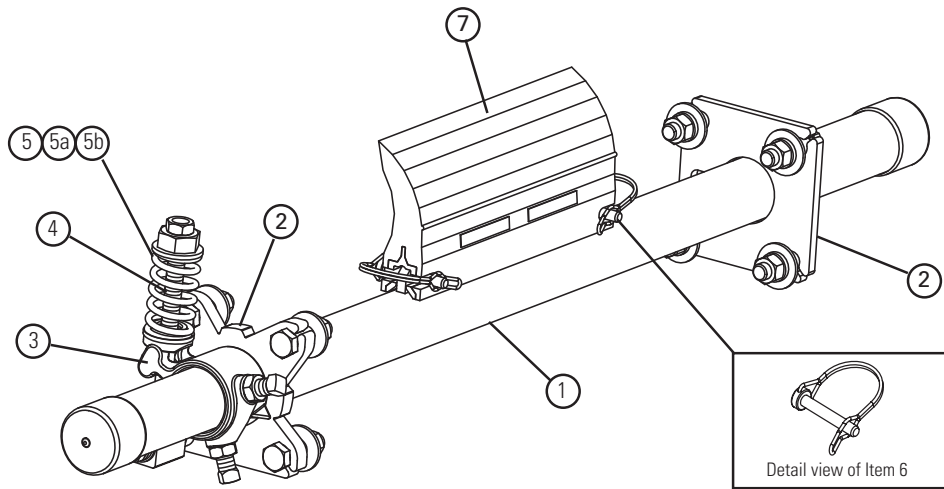

Replacement Parts

REF	DESCRIPTION	ORDERING NUMBER	ITEM CODE	WT. KG.
1	300 mm Pole	LSP12	77070	6.0
	450 mm Pole	LSP18	77071	7.0
	600 mm Pole	LSP24	77072	8.0
	750 mm Pole	LSP30	77073	9.0
	900 mm Pole	LSP36	77074	10.0
	1050 mm Pole	LSP42	77075	11.0
	1200 mm Pole	LSP48	77076	12.0
	1500 mm Pole	LSP60	77078	14.1
2	Mounting Plate Kit* (incl. 1 tensioner mounting plate and 1 pole mounting plate)	LSTMPK	77366	1.6
3	Torque Arm Kit* (1 ea.)	LST-TAK	77120	0.6
4	Pivot Block/Rod Kit* (1 ea.)	LSTPB-RK	77367	0.4
5	Tension Spring - Purple (1 ea.) for blades 250-400 mm	LS-SP	77365	0.1
5a	Tension Spring - White (1 ea.) for blades 550 - 1150 mm	LS-SW	77117	0.1
5b	Tension Spring - Silver (1 ea.) for blades 1300 - 1450 mm	LS-SS	77118	0.1
6	LS Blade Pin (1 ea.)	LS-BP	77114	0.0
-	LST Spring Tensioner* - Purple incl. 1 tensioner mounting plate and 1 ea. items 3, 4 & 5 for blades 250-400 mm	LST-P	77121	3.4
-	LST Spring Tensioner* - White incl. 1 tensioner mounting plate and 1 ea. items 3, 4 & 5a for blades 550 - 1150 mm	LST-W	77122	3.5
-	LST Spring Tensioner* - Silver incl. 1 tensioner mounting plate and 1 ea. items 3, 4 & 5b for blades 1300 - 1450 mm	LST-S	77123	3.5

Hardware Included

Spring Tensioner Selection Chart

CLEANER BLADE WIDTH	77121 PURPLE	77122 WHITE	77123 SILVER
ConShear-LS 250 - 400 mm	X		
ConShear-LS 550 - 1150 mm		X	
ConShear-LS 1300 - 1450 mm			X

U.S. Patent No. D482,508S (blade)
Patent Pending (tensioner)

For best results use Flexco® Genuine Replacement Blades and Parts.

Replacement Parts List

EZP-LS Stainless Steel Limited Space Primary Cleaner

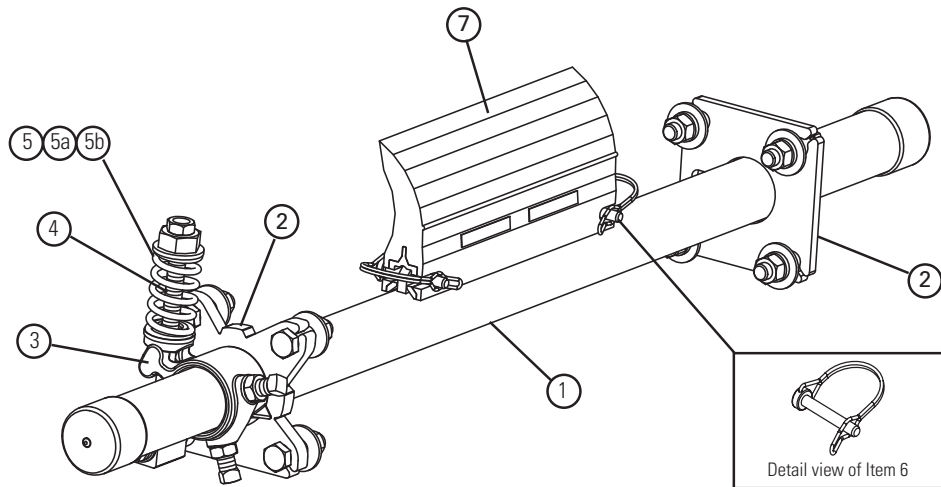

Replacement Parts

REF	DESCRIPTION	ORDERING NUMBER	ITEM CODE	WT. KG.
1	300 mm SS Pole	LSP12-S/S	77079	6
	450 mm SS Pole	LSP18-S/S	77080	7
	600 mm SS Pole	LSP24-S/S	77081	8
	750 mm SS Pole	LSP30-S/S	77082	9
	900 mm SS Pole	LSP36-S/S	77083	10
	1050 mm SS Pole	LSP42-S/S	77084	11
	1200 mm SS Pole	LSP48-S/S	77085	12
	1350 mm SS Pole	LSP54-S/S	77086	13
	1500 mm SS Pole	LSP60-S/S	77087	14.1
2	SS Mounting Plate Kit (10"-46"/250-1150mm)* (incl. 1 tensioner mounting plate and 1 pole mounting plate)	LSTMPK-S/S	78933	1.6
2a	SS Mounting Plate Kit (52"+/1300mm+)* (incl. 2 tensioner mounting plates)	LSTMPK2-S/S	78462	3.3
3	Torque Arm Kit* (1 ea.)	LST-TAK	77120	0.6
4	Pivot Block/Rod Kit* (1 ea.)	LSTPB-RK	77367	0.4
5	Tension Spring - Black (1 ea.) for blades 10'-28" (250-700mm)	CTS-B-S/S	78387	0.1
5a	Tension Spring - White (1 ea.) for blades 34" - 70" (850 - 1750mm)	LS-SW-S/S	78850	0.1
5b	Tension Spring - Silver (1 ea.) for blades 1300 - 1450 mm)	LS-SS	77118	0.1
6	SS LS Blade Pin (1 ea.)	LS-BP-S/S	77115	0
-	SS LST Spring Tensioner* - Black incl. 1 ea. items 2 & 3 for blades 10'-28" (250 - 700mm)	LST-B-S/S	77124	3.4
-	SS LST Spring Tensioner* - White incl. 1 ea. items 2 & 3a for blades 34"- 46" (850 - 1150mm)	LST-W-S/S	77125	3.5
-	SS LST Spring Tensioner* - White (dual) incl. 1 ea. item 2a and 2 ea. item 3a for blades 52"- 70" (1300 - 1750mm)	LST-W-S/S-2	77126	6.9

Hardware Included

 **Stock items** (non-shaded) refer to (*) for specific lead time, if not specified, standard lead time applies.

 **Non-stock items** (shaded) please contact Flexco for dispatch options and lead times.

U.S. Patent No. D482,508S (blade)
Patent Pending (tensioner)

For best results use Flexco® Genuine Replacement Blades and Parts.

Spring Tensioner Selection Chart

CLEANER BLADE WIDTH	77124 BLACK	77125 WHITE	77126 WHITE (Dual)
ConShear-LS 250 - 700 mm	X		
ConShear-LS 850 - 1150 mm		X	
ConShear-LS 1300 - 1750 mm			X

Replacement Parts List

EZP-LS *Limited Space Primary Cleaner and Stainless Steel Limited Space Primary Cleaner*

Ordering Information ConShear™-LS Replacement Blades

BELT WIDTH mm	BLADE WIDTH mm	ORDERING NUMBER	ITEM CODE	WT. KG.
300	250	CRB-LS10	77088	1.0
450	400	CRB-LS16	77089	1.5
600	550	CRB-LS22	77090	2.1
750	700	CRB-LS28	77091	2.6
900	850	CRB-LS34	77092	3.2
1050	1000	CRB-LS40	77093	3.8
1200	1150	CRB-LS46	77094	4.4
1350	1300	CRB-LS52	77095	4.9
1500	1450	CRB-LS58	77096	5.5

Other blade sizes available upon request.

Ordering Information ConShear™-LS High-Temp Replacement Blades

BLADE WIDTH mm	ORDERING NUMBER	ITEM CODE	WT. LBS.
400	CRB-LS16HT	77552	1.5
550	CRB-LS22HT	77553	2.1
700	CRB-LS28HT	77554	2.6
850	CRB-LS34HT	77555	3.2
1000	CRB-LS40HT	77556	3.8
1150	CRB-LS46HT	77557	4.4
1300	CRB-LS52HT	77558	4.9
1450	CRB-LS58HT	77559	5.5

Other blade sizes available upon request.

Ordering Information White ConShear™-LS Replacement Blades (Chemical Resistant/Food Grade) ‡

BLADE WIDTH mm	ORDERING NUMBER	ITEM CODE	WT. KG.
250	CRB-LS10W	77097	1.0
400	CRB-LS16W	77098	1.5
550	CRB-LS22W	77099	2.1
700	CRB-LS28W	77100	2.6
850	CRB-LS34W	77101	3.2
1000	CRB-LS40W	77102	3.8
1150	CRB-LS46W	77103	4.4
1300	CRB-LS52W	77104	4.9
1450	CRB-LS58W	77105	5.5

‡ All ingredients used in the urethane formulation of this blade comply with the relevant requirements of 21 CFR (FDA Code of Federal Regulations) for use in repeated bulk dry food applications

Stock items (non-shaded) refer to (*) for specific lead time, if not specified, standard lead time applies.

Non-stock items (shaded) please contact Flexco for dispatch options and lead times.

Product Ordering Information

EZP1 Standard Duty Primary Cleaner and EZP1 Stainless Steel Primary Cleaner



Ordering Information EZP1 Primary Cleaner Belt Width Minus 50mm

BELT WIDTH mm	BLADE COVERAGE mm	ORDERING NUMBER	ITEM CODE	WT. KG.
450	400	EZP1-218	75611	25.1
600	550	EZP1-224	75612	27.8
750	700	EZP1-230	75613	30.5
900	850	EZP1-236	75614	33.2
1050	1000	EZP1-242	75615	35.9
1200	1150	EZP1-248	75616	38.6
1350	1300	EZP1-254	75617	41.2
1500	1450	EZP1-260	75618	43.9
1800	1750	EZP1-272	75771	46.6

Ordering Information EZP1 High Temp Primary Cleaner Belt Width Minus 50mm

BELT WIDTH mm	BLADE COVERAGE mm	ORDERING NUMBER	ITEM CODE	WT. KG.
300	250	HTF212	76658	22
450	400	HTF218	76659	25.1
600	550	HTF224	76660	27.8
750	700	HTF230	76661	30.5
900	850	HTF236	76662	33.2
1050	1000	HTF242	76663	35.9
1200	1150	HTF248	76664	38.6
1350	1300	HTF254	76665	41.2
1500	1450	HTF260	76666	43.9
1800	1750	HTF272	76667	46.6

Ordering Information EZP1 Primary Cleaner Stainless Steel

BELT WIDTH mm	BLADE COVERAGE mm	ORDERING NUMBER	ITEM CODE	WT. KG.
450	400	EZP1-218-S/S	61081	25.7
600	550	EZP1-224-S/S	61082	28.4
750	700	EZP1-230-S/S	61017	31.1
900	850	EZP1-236-S/S	61083	33.9
1050	1000	EZP1-242-S/S	61016	36.6
1200	1150	EZP1-248-S/S	61084	39.3
1350	1300	EZP1-254-S/S	61085	42
1500	1450	EZP1-260-S/S	61086	44.8
1800	1750	EZP1-272-S/S	61087	47.5

Other blade sizes available upon request.

Ordering Information EZP1 Primary Cleaner Stainless Steel High Temp Belt Width Minus 50mm

BELT WIDTH mm	BLADE COVERAGE mm	ORDERING NUMBER	ITEM CODE	WT. KG.
300	250	HTF212-S/S	62826	22.0
450	400	HTF218-S/S	62827	25.1
600	550	HTF224-S/S	62828	27.8
750	700	HTF230-S/S	62829	30.5
900	850	HTF236-S/S	62830	33.2
1050	1000	HTF242-S/S	62831	35.9
1200	1150	HTF248-S/S	62832	38.6
1350	1300	HTF254-S/S	62833	41.2
1500	1450	HTF260-S/S	62834	43.9
1800	1750	HTF272-S/S	62835	46.6

Ordering Information EZP1 Stainless Steel Primary Cleaner with White ConShear Blade Belt Width Minus 50mm

BELT WIDTH mm	BLADE COVERAGE mm	ORDERING NUMBER	ITEM CODE	WT. KG.
300	250	CFG-212	78838	22.5
450	400	CFG-218	78839	25.1
600	550	CFG-224	78840	27.8
750	700	CFG-230	78841	30.5
900	850	CFG-236	78842	33.2
1050	1000	CFG-242	78843	35.9
1200	1150	CFG-248	78844	38.5
1350	1300	CFG-254	78845	41.2
1500	1450	CFG-260	78846	43.9
1800	1750	CFG-272	78847	46.6

Stock items (non-shaded) refer to (*) for specific lead time, if not specified, standard lead time applies.

Non-stock items (shaded) please contact Flexco for dispatch options and lead times.

U.S. Patent No. D482,508S

Specifications & Guidelines

EZP1 Standard Duty Primary Cleaner

Pole Length Specifications*

CLEANER SIZE mm	POLE LENGTH mm	MAXIMUM CONVEYOR SPAN mm
300	1050	925
450	1200	1075
600	1350	1225
750	1500	1375
900	1650	1525
1050	1800	1675
1200	1950	1825
1350	2200	2075
1500	2350	2225
1800	2650	2525

Pole Diameter - 60mm

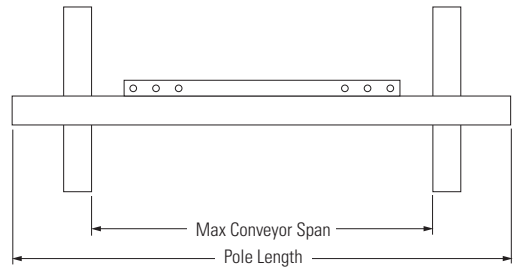

Clearance Guidelines for Installation

HORIZONTAL CLEARANCE REQUIRED mm	VERTICAL CLEARANCE REQUIRED mm
100	238

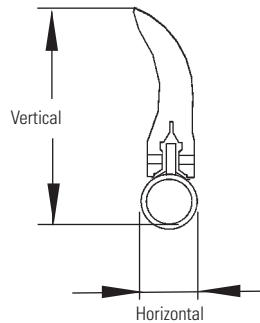

Spring Length Chart with EST Spring Tensioner

BLADE WIDTH mm	PURPLE SPRING mm	SILVER SPRING mm	BLACK SPRING mm
254	146	159	N/A
406	133	152	N/A
559	121	149	N/A
711	108	143	N/A
864	N/A	137	143
1016	N/A	130	140
1168	N/A	127	133
1321	N/A	121	130
1473	N/A	N/A	127
1626	N/A	N/A	121
1778	N/A	N/A	118

Shading indicates preferred spring option

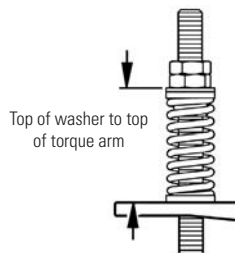

Specifications:

- Maximum Belt SpeedContact Flexco®
- Temperature Rating-35°C to 82°C
- Minimum Pulley Diameter.....250mm
- Usable Blade Wear Length.....100mm
- BladePolyurethane (proprietary blend for abrasion resistance and long wear)
- Available for Belt Widths300 to 1800 mm

U.S. Patent No. D482,508S

Pole Location Specs

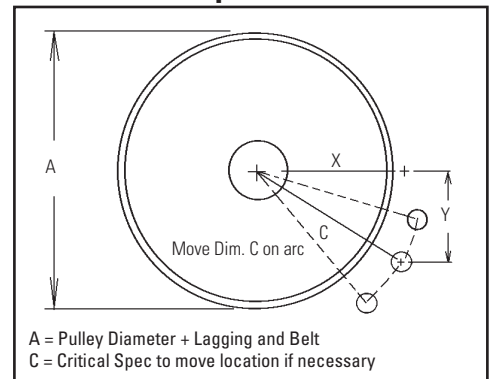

Pole Location Chart

A	X	Y	C
254	76	229	241
279	95	229	248
305	111	229	254
330	137	229	267
356	149	229	273
381	171	229	286
406	181	229	292
432	200	229	305
457	210	229	311
483	229	229	324
508	238	229	330
533	254	229	343
559	273	229	356
584	289	229	368
610	305	229	381
635	321	229	394
660	337	229	406
686	353	229	419
711	365	229	432
737	381	229	445
762	397	229	457
787	410	229	470
813	425	229	483
838	438	229	495
864	454	229	508
889	467	229	521
914	483	229	533

Replacement Parts List

EZP1 Standard Duty Primary Cleaner

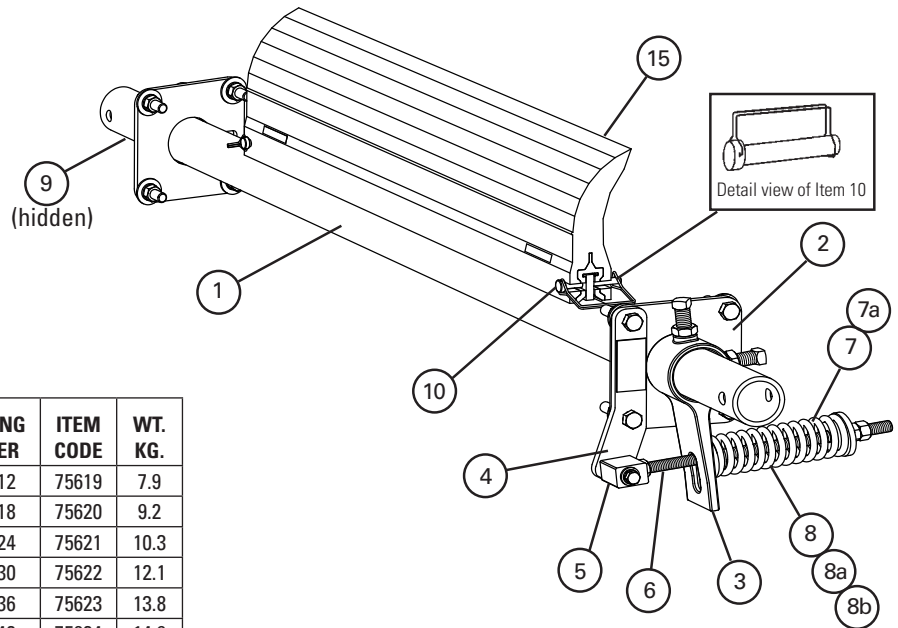

Replacement Parts

REF	DESCRIPTION	ORDERING NUMBER	ITEM CODE	WT. KG.
1	300 mm Pole	EZP1P12	75619	7.9
	450 mm Pole	EZP1P18	75620	9.2
	600 mm Pole	EZP1P24	75621	10.3
	750 mm Pole	EZP1P30	75622	12.1
	900 mm Pole	EZP1P36	75623	13.8
	1050 mm Pole	EZP1P42	75624	14.9
	1200 mm Pole	EZP1P48	75625	16.1
	1350 mm Pole	EZP1P54	75626	17.8
	1500 mm Pole	EZP1P60	75627	19.7
	1800 mm Pole	EZP1P72	75772	21.9
2	Mounting Plate Kit* (2 ea.)	EZP1MPK	75637	3.5
3	Torque Arm Kit* (1 ea.)	ESTAK	76406	1.6
4	Pivot Shaft Bracket Kit* (1 ea.)	ESPSBK	76407	0.8
5	Pivot Block Kit*	ESPBK	76408	0.3
6	Pivot Rod Kit*	ESPRK	76409	0.6
7	Bushing Kit - Purple and Silver (includes 2 bushings)	ESBK-PS	76410	0.1
7a	Bushing Kit - Black (includes 2 bushings)	ESBK-B	76411	0.1
8	Tension Spring - Purple	QMTS-P	75845	0.5
8a	Tension Spring - Silver	ESS-S	76412	0.6
8b	Tension Spring - Black	ESS-B	76413	0.6
9	Pole Lock* (1 ea.)	EZP1PL	75641	0.5
-	EST Tensioner - Purple* for blade widths 300 - 700 mm (includes 1 each items 3, 4, 5, 6, 7 & 8)	EST-P	76403	3.5
-	EST Tensioner - Silver* for blade widths 850 - 1300 mm (includes 1 each items 3, 4, 5, 6, 7 & 8a)	EST-S	76404	3.6
-	EST Tensioner - Black* for blade widths 1450 - 1750 mm (includes 1 each items 3, 4, 5, 6, 7a & 8b)	EST-B	76405	3.7
10	Blade Pin (1 ea.)	EZP1BP	75642	0.1

*Hardware Included

Spring Tensioner Selection Chart

CLEANER BLADE WIDTH	76403 EST-P	76404 EST-S	76405 EST-B
ConShear™ 300 - 700 mm	X		
ConShear 850 - 1300 mm		X	
ConShear 1450 - 1750 mm			X

Stock items (non-shaded) refer to (*) for specific lead time, if not specified, standard lead time applies.

Non-stock items (shaded) please contact Flexco for dispatch options and lead times.

U.S. Patent No. D482,508S

Replacement Parts List

EZP1 Stainless Steel Primary Cleaner

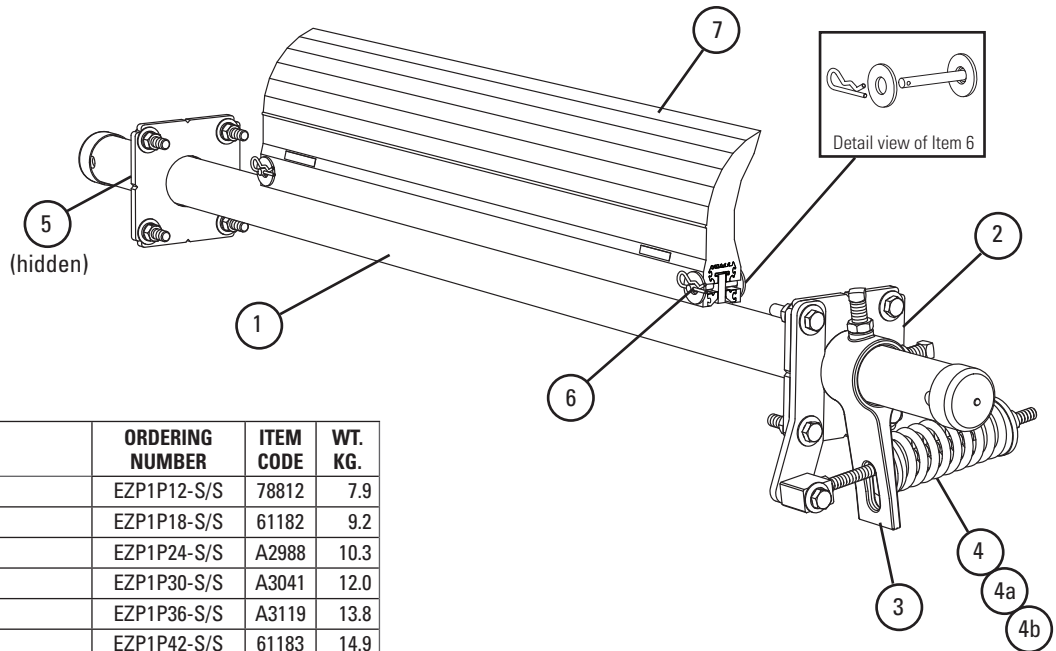

Replacement Parts

REF	DESCRIPTION	ORDERING NUMBER	ITEM CODE	WT. KG.
1	300 mm S/S Pole	EZP1P12-S/S	78812	7.9
	450 mm S/S Pole	EZP1P18-S/S	61182	9.2
	600 mm S/S Pole	EZP1P24-S/S	A2988	10.3
	750 mm S/S Pole	EZP1P30-S/S	A3041	12.0
	900 mm S/S Pole	EZP1P36-S/S	A3119	13.8
	1050 mm S/S Pole	EZP1P42-S/S	61183	14.9
	1200 mm S/S Pole	EZP1P48-S/S	61491	16.0
	1350 mm S/S Pole	EZP1P54-S/S	61184	17.8
	1500 mm S/S Pole	EZP1P60-S/S	61185	19.7
	1800 mm S/S Pole	EZP1P72-S/S	61186	21.9
2	SS Mounting Plate Kit* (2 ea.)	EZP1MPK-S/S	78923	3.5
3	SS Torque Arm Kit* (1 ea.)	ESTAK-EST-S/S	78849	1.6
4	SS Tension Spring - Purple	QMTS-P-S/S	77450	0.5
4a	SS Tension Spring - White	QMTS-W-S/S	77451	0.5
4b	SS Tension Spring - Gold	QMTS-G-S/S	77452	0.6
5	SS Pole Lock* (1 ea.)	EZP1PL-S/S	78848	0.5
-	SS EST Tensioner - Purple* for blade widths 12" - 28" (300 - 700mm) (includes 1 each items 2, 3, 4)	EST-P-S/S	78808	3.5
-	SS EST Tensioner - White* for blade widths 34" - 52" (850 - 1300mm) (includes 1 each items 2, 3, 4a)	EST-W-S/S	78809	3.6
-	SS EST Tensioner - Gold* for blade widths 58" - 70" (1450 - 1750mm) (includes 1 each items 2, 3, 4b)	EST-G-S/S	78810	3.7
6	Blade Pin (1 ea.)	MSPBPK-S/S	77583	0.0

*Hardware Included

Stainless Steel Spring Tensioner Selection Chart

CLEANER BLADE WIDTH	78808 EST-P-S/S	78809 EST-W-S/S	78810 EST-G-S/S
ConShear™ 300 - 700 mm	X		
ConShear 850 - 1300 mm		X	
ConShear 1450 - 1750 mm			X

Stock items (non-shaded) refer to (*) for specific lead time, if not specified, standard lead time applies.

Non-stock items (shaded) please contact Flexco for dispatch options and lead times.

Replacement Parts List

EZP1 Standard Duty Primary Cleaner and EZP1 Stainless Steel Primary Cleaner

Ordering Information ConShear™ Replacement Blades

BELT WIDTH mm	BLADE COVERAGE mm	ORDERING NUMBER	ITEM CODE	WT. KG.
450	400	CRB16	75629	3.3
600	550	CRB22	75630	4.6
750	700	CRB28	75631	5.8
900	850	CRB34	75632	7.1
1050	1000	CRB40	75633	8.0
1200	1150	CRB46	75634	9.6
1350	1300	CRB52	75635	10.8
1500	1450	CRB58	75636	12.1
1650	1600	CRB64	75775	13.3
1800	1750	CRB70	75773	14.6

Other blade sizes available upon request.

Ordering Information ConShear High Temp Replacement Blades

BELT WIDTH mm	BLADE COVERAGE mm	ORDERING NUMBER	ITEM CODE	WT. KG.
300	250	CRB-HT10	76593	2.2
450	400	CRB-HT16	76594	3.5
600	550	CRB-HT22	76595	4.7
750	700	CRB-HT28	76596	6
900	850	CRB-HT34	76597	7.4
1050	1000	CRB-HT40	76598	8.7
1200	1150	CRB-HT46	76599	13
1350	1300	CRB-HT52	76600	11.3
1500	1450	CRB-HT58	76601	12.6
1650	1600	CRB-HT64	76602	13.9
1800	1750	CRB-HT70	76603	15.2

Ordering Information White ConShear™ Replacement Blades (Chemical Resistant/Food Grade) ‡

BELT WIDTH mm	BLADE COVERAGE mm	ORDERING NUMBER	ITEM CODE	WT. KG.
450	400	CRB-W16	78472	3.3
600	550	CRB-W22	78473	4.6
750	700	CRB-W28	78474	5.8
900	850	CRB-W34	78475	7.1
1050	1000	CRB-W40	78476	8.0
1200	1150	CRB-W46	78477	9.6
1350	1300	CRB-W52	78478	10.8
1500	1450	CRB-W58	78479	12.1
1650	1600	CRB-W64	78480	13.3
1800	1750	CRB-W70	78481	14.6

‡ All ingredients used in the urethane formulation of this blade comply with the relevant requirements of 21 CFR (FDA Code of Federal Regulations) for use in repeated bulk dry food applications

Stock items (non-shaded) refer to (*) for specific lead time, if not specified, standard lead time applies.

Non-stock items (shaded) please contact Flexco for dispatch options and lead times.

Product Ordering Information

EZP1T Twist Tensioner Primary Cleaner

EZP1T Primary Cleaner with Twist Tensioner Belt Width Minus 2" (50mm)



BELT WIDTH		BLADE WIDTH		ORDERING NUMBER	ITEM CODE	WT. KG.
in.	mm	in.	mm			
12	300	10	250	EZP1T-212	78488	38.5
18	450	16	400	EZP1T-218	78489	44.5
24	600	22	550	EZP1T-224	78490	50.5
30	750	28	700	EZP1T-230	78491	56.5
36	900	34	850	EZP1T-236	78492	62.5
42	1050	40	1000	EZP1T-242	78493	68.4
48	1200	46	1150	EZP1T-248	78494	74.4
54	1350	52	1300	EZP1T-254	78495	83.7
60	1500	58	1450	EZP1T-260	78496	92.0
72	1800	70	1750	EZP1T-272	78497	101.6

Product Notes:

- For optimal cleaning and reduced blade retensioning maintenance, the cleaner blade width should be sized to fit the material path of the belt. The material path is typically 2/3 of the belt width. In most cases a blade size of belt width minus 200mm may be the best selection.
- Each cleaner can be retrofitted with three replacement blade sizes (belt width minus 50mm, minus 200mm, or minus 350mm).
- Comes complete with universal mounting plates and tensioner.
- Visual tension check. No guesswork on blade tensioning. Simply measure the spring, check label on tensioner and turn adjusting nut to restore optimal tension.
- Works with mechanical splices. Polyurethane blade glides over splices.
- Compatible with reversing belts.
- For applications requiring longer pole lengths, go to the minus 200mm chart and select the cleaner one belt width size larger. This will provide a pole 150mm longer and a blade size of belt width minus 50mm.

Stock items (non-shaded) refer to (*) for specific lead time, if not specified, standard lead time applies.

Non-stock items (shaded) please contact Flexco for dispatch options and lead times.

U.S. Patent No. D482,508S

Replacement Parts List

EZP1T Twist Tensioner Primary Cleaner

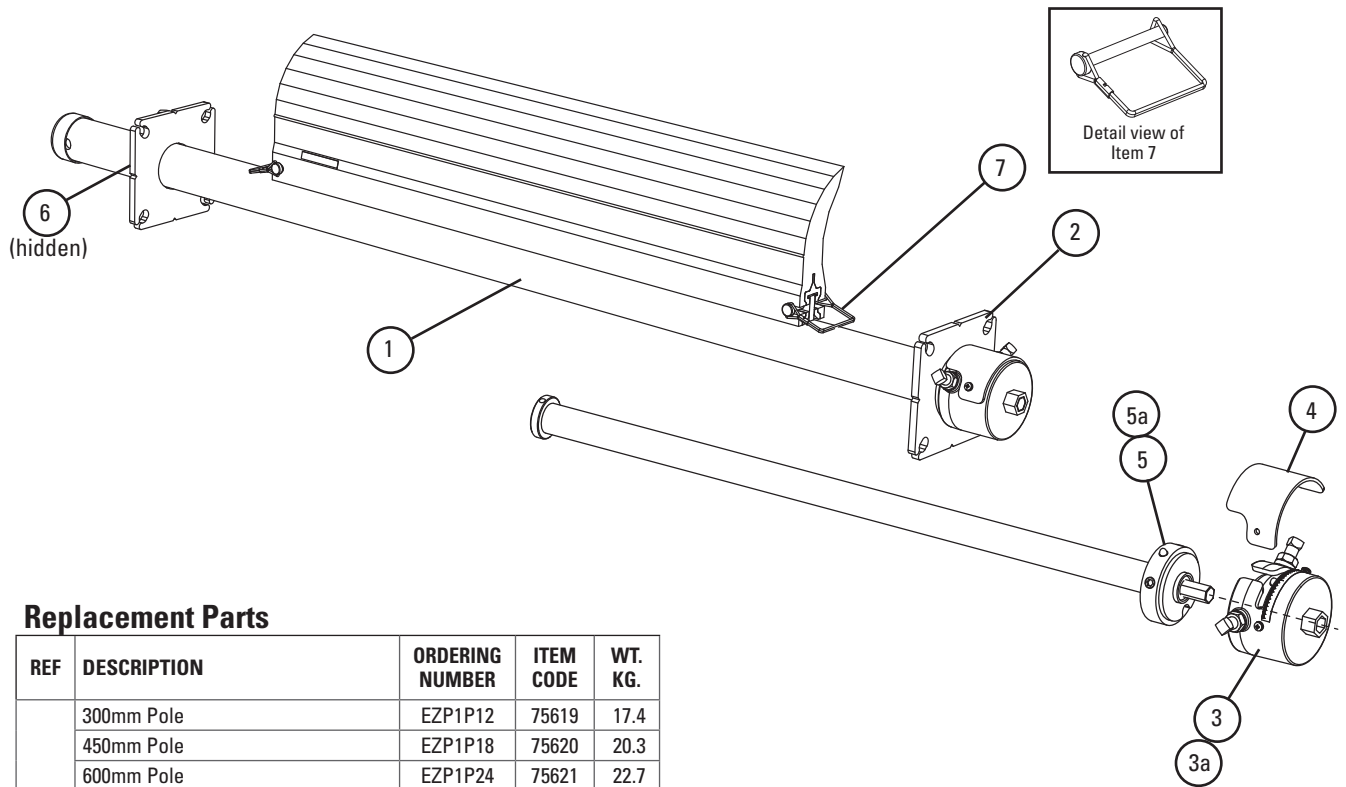

Replacement Parts

REF	DESCRIPTION	ORDERING NUMBER	ITEM CODE	WT. KG.
1	300mm Pole	EZP1P12	75619	17.4
	450mm Pole	EZP1P18	75620	20.3
	600mm Pole	EZP1P24	75621	22.7
	750mm Pole	EZP1P30	75622	26.5
	900mm Pole	EZP1P36	75623	30.4
	1050mm Pole	EZP1P42	75624	32.7
	1200mm Pole	EZP1P48	75625	35.3
	1350mm Pole	EZP1P54	75626	39.2
	1500mm Pole	EZP1P60	75627	43.3
	1800mm Pole	EZP1P72	75772	48.2
2	Torsion Mounting Plate Kit* (2 ea.)	EZPTMPK	78507	8.7
3	Torsion Cap Kit* (1 ea.) (includes 1 ea. Item 4)	EZPTCK	78508	3.2
3a	Torsion Cap Kit HD* (1 ea.) (includes 1 ea. Item 4)	EZPTCKHD	78509	3.2
4	Torsion Shield	EZPTSR	78510	.1
5	Torsion Spring Kit	EZPTSK	78511	6.0
5a	Torsion Spring Kit HD	EZPTSKHD	78512	8.5
6	Pole Lock* (1 ea.)	EZP1PL	75641	1.1
-	Torsion Bar Tensioner for blade widths 300 - 1200mm (includes 1 each items 3, 4, & 5)	EZPTBT	77384	17.4
-	Torsion Bar Tensioner HD for blade widths 1350 - 1800mm (includes 1 each items 3a, 4, & 5a)	EZPTBTHD	77385	20.0
7	Blade Pin (1 ea.)	EZP1BP	75642	0.1

*Hardware Included

Torsion Bar Tensioner Selection Chart

CLEANER BLADE WIDTH	77384 EZPTBT	77385 EZPTBTHD
ConShear 300 - 1200mm	X	
ConShear 1350 - 1800mm		X

U.S. Patent No. D482,508S

Stock items (non-shaded) refer to (*) for specific lead time, if not specified, standard lead time applies.

Non-stock items (shaded) please contact Flexco for dispatch options and lead times.

Product Ordering Information

Spring Covers and Tensioner Lock

Spring Covers

ORDERING NUMBER	ITEM CODE	WT. KG.
SPG-CVR-A	77387	0.14
SPG-CVR-B	77388	0.14
SPG-CVR-C	77389	0.14
SPG-CVR-D	77390	0.18
SPG-CVR-E	77391	0.18
SPG-CVR-F	77392	0.14
SPG-CVR-G	77393	0.14
SPG-CVR-H	77741	0.14

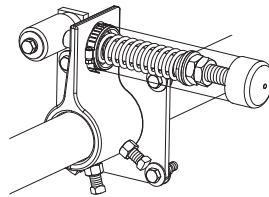
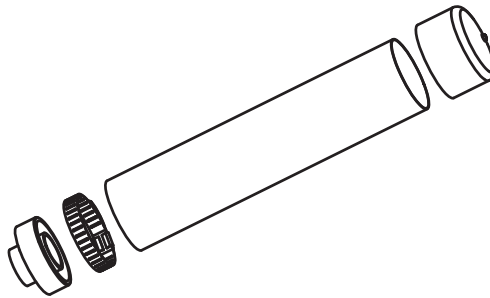

Spring cover on Primary Cleaner tensioner

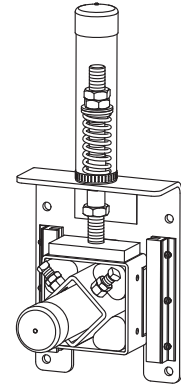

Spring cover on Secondary cleaner tensioner

Tensioner Lock

Designed to prevent tampering or unauthorized retensioning of the cleaner.

ORDERING NUMBER	ITEM CODE	WT. KG.
TEN-LOCK-KIT	77443	0.18

*For MSP, MMP, MHP, MHCP, H-Type® Primary Cleaner and MSS, MHS, MDWS Secondary Cleaners

Includes 1 tensioner lock
Lead time: 1 working day

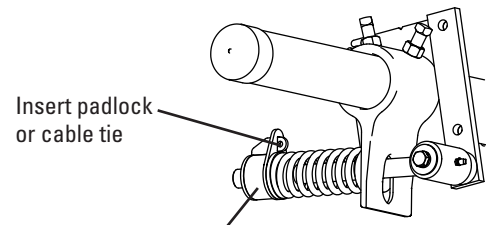
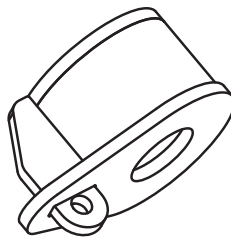

Tensioner Lock

(Primary Cleaner tensioner shown)

Patent pending

 **Stock items** (non-shaded) refer to (*) for specific lead time, if not specified, standard lead time applies.

 **Non-stock items** (shaded) please contact Flexco for dispatch options and lead times.

Product Ordering Information

MMP Medium Mine-Duty Primary Cleaner

MMP Medium-Duty Primary Cleaner Belt Width Minus 150mm Blade

BELT WIDTH mm	BLADE COVERAGE mm	ORDERING NUMBER	ITEM CODE	WT. KG.
600	450	MMP-624	76450	72.4
750	600	MMP-630	76451	79.6
900	750	MMP-636	76452	86.6
1050	900	MMP-642	76453	93.7
1200	1050	MMP-648	76454	100.8
1350	1200	MMP-654	76455	107.9
1500	1350	MMP-660	76456	115.0
1800	1650	MMP-672	76457	132.3
2100	1950	MMP-684	76798	156.4



Blade Width Selection

BELT WIDTH mm	ITEM CODE		
	BELT WIDTH MINUS 150 mm	BELT WIDTH MINUS 300 mm	BELT WIDTH MINUS 450 mm
600	76485	N/A	N/A
750	76486	76485	N/A
900	76487	76486	76485
1050	76488	76487	76486
1200	76489	76488	76487
1350	76490	76489	76488
1500	76491	76490	76489
1800	76493	76492	76491
2100	76697	76494	76493
2400	77048	77047	76697



TuffShear™
Replacement Blades

Ordering Information TuffShear™ Replacement Blades

BLADE WIDTH mm	ORDERING NUMBER	ITEM CODE	WT. KG.
450	TRB18	76485	9.6
600	TRB24	76486	12.7
750	TRB30	76487	15.9
900	TRB36	76488	19.1
1050	TRB42	76489	22.3
1200	TRB48	76490	25.5
1350	TRB54	76491	28.6
1500	TRB60	76492	31.8
1650	TRB66	76493	35.0
1800	TRB72	76494	38.2
1950	TRB78	76697	41.4

Other blade sizes available upon request.

Product Notes:

- Recommended for medium-duty conveyor applications. For abusive applications see the MHP Heavy-Duty Primary Cleaner or the MHCP Heavy-Duty Cartridge Primary Cleaner.
- Pole Length: Belt width plus 1350 mm. For longer requirements see Installation Accessories - Pole Extender Kit.
- Visual Tension Check: No guesswork on blade tensioning. Measure the spring and adjust to specified length per blade width to restore optimal tensioning.

Stock items (non-shaded) refer to (*) for specific lead time, if not specified, standard lead time applies.

Non-stock items (shaded) please contact Flexco for dispatch options and lead times.

Product Ordering Information

Stainless Steel MMP Medium Mine-Duty Primary Cleaner

Stainless Steel MMP Medium-Duty Primary Cleaner Belt Width Minus 150mm Blade

BELT WIDTH mm	BLADE WIDTH mm	ORDERING NUMBER	ITEM CODE
600	450	MMP-624-S/S	77424
750	600	MMP-630-S/S	77425
900	750	MMP-636-S/S	77426
1050	900	MMP-642-S/S	77427
1200	1050	MMP-648-S/S	77428
1350	1200	MMP-654-S/S	77429
1500	1350	MMP-660-S/S	77430
1800	1650	MMP-672-S/S	77431
2100	1950	MMP-684-S/S	77432

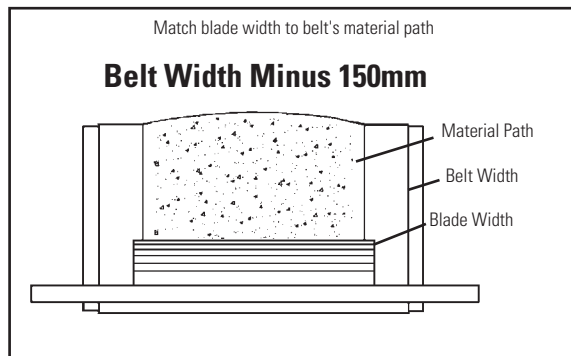

Product Notes:

- Recommended for medium-duty conveyor applications, but in corrosive environments.
- Material Path Option: Fit the blade width to the belt's material path. The material path is typically the center 2/3 of the belt width. In most cases a blade size of belt width minus 152 mm may be the best solution.
- Each cleaner pole is retrofittable for three blade sizes (belt width minus 152 mm, minus 305 mm or minus 457 mm).
- Pole Length: Belt width plus 1372 mm. For longer requirements see Installation Accessories - Pole Extender Kit.
- Visual Tension Check: No guesswork on blade tensioning. Measure the spring and adjust to specified length per blade width to restore optimal tensioning.
- To make cleaner installation easier and quicker, see Optional Mounting Kits.

Stock items (non-shaded) refer to (*) for specific lead time, if not specified, standard lead time applies.

Non-stock items (shaded) please contact Flexco for dispatch options and lead times.

U.S. Patent No. D482,508S

Replacement Parts List

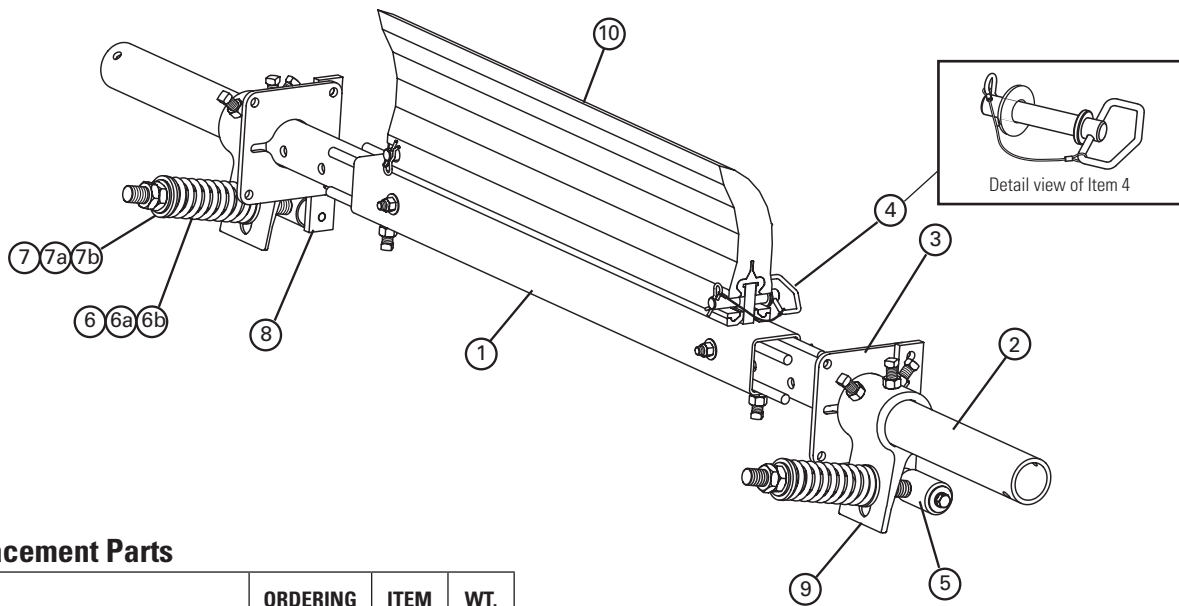

Replacement Parts

REF	DESCRIPTION	ORDERING NUMBER	ITEM CODE	WT. KG.
1	600 mm Pole	MMPCP24	76458	15.6
	750 mm Pole	MMPCP30	76459	19.6
	900 mm Pole	MMPCP36	76460	23.5
	1050 mm Pole	MMPCP42	76461	27.3
	1200 mm Pole	MMPCP48	76462	31.2
	1350 mm Pole	MMPCP54	76463	35.1
	1500 mm Pole	MMPCP60	76464	39.1
	1800 mm Pole	MMPCP72	76465	46.9
	2100 mm Pole	MMPCP84	76808	54.7
2	Extender Pole Kit (2 ea.)	MHP-EP	76392	24.6
3	Mounting Plate Kit* (2 ea.)	MSPMPK	75811	3.8
4	Blade Pin Kit* (1 ea.)	MMPBPK	76466	0.4
5	Pivot Arm Kit* (1 ea.)	QMTPAK	76096	2.0
6	Tension Spring - Purple (1 ea.) for blades 600 mm	QMTS-P	75845	0.3
6a	Tension Spring - White (1 ea.) for blades 750 - 1200 mm	PSTS-W	75898	0.8
6b	Tension Spring - Gold (1 ea.) for blades 1350 - 1950 mm	QMTS-G	76484	1.1
7	Bushing Kit - Purple (2 ea.)	QMTBK-P	76097	0.1
7a	Bushing Kit - White (2 ea.)	QMTBK-W	76098	0.1
7b	Bushing Kit - Gold (2 ea.)	QMTBK-G	76540	0.1
8	Pivot Shaft Bracket Kit* (1 ea.)	QMTPSBK	76099	2.0
9	Torsion Arm Kit* (1 ea.)	PSTA	75896	5.2
-	QMT Spring Tensioner* - Purple (incl. 1 ea. Items 5, 6, 7, 8, & 9) for blades 450 - 600 mm	QMT-P	76074	9.3
-	QMT Spring Tensioner* - White (incl. 1 ea. Items 5, 6a, 7a, 8, & 9) for blades 750 - 1200 mm	QMT-W	76075	10.0
-	QMT Spring Tensioner* - Gold (incl. 1 ea. Items 5, 6b, 7b, 8, & 9) for blades 1350 - 1950 mm	QMT-G	76483	10.6

*Hardware Included

Replacement TuffShear™ Blades

REF	BLADE WIDTH mm	ORDERING NUMBER	ITEM CODE	WT. KG.
10	450	TRB18	76485	9.6
	600	TRB24	76486	12.7
	750	TRB30	76487	16.0
	900	TRB36	76488	19.1
	1050	TRB42	76489	22.3
	1200	TRB48	76490	25.5
	1350	TRB54	76491	28.6
	1500	TRB60	76492	31.8
	1650	TRB66	76493	35.0
	1800	TRB72	76494	38.2
	1950	TRB78	76697	41.4
	2100	TRB84	77047	44.5
	2400	TRB90	77048	47.6

Order blade width for your belt width's material path:
Belt Width Minus 152 mm, Belt Width Minus 305 mm, or Belt Width Minus 457 mm.

Spring Tensioner Selection Chart

CLEANER BLADE WIDTH	76403 EST-P	76404 EST-S	76405 EST-B
TuffShear 450 - 600 mm	X		
TuffShear 750 - 1200 mm		X	
TuffShear 1350 - 1950 mm			X

Stock items (non-shaded) refer to (*) for specific lead time, if not specified, standard lead time applies.

Non-stock items (shaded) please contact Flexco for dispatch options and lead times.

U.S. Patent No. D482,508S

Replacement Parts List

MMP
Medium Mine-Duty Primary Cleaner

Air/Water Tensioner Replacement Parts

REF	DESCRIPTION	ORDERING NUMBER	ITEM CODE	WT. KG.
12	Air/Water Bag (1 ea.)	AWTB	75905	1.7
13	Mounting Base (1 ea.)	AWTMB	75906	10.4
14	Torque Arm* (1 ea.)	AWTA	75907	5.3
15	Hose Kit (15 M of hose and 6 hose clamps)	AWTHK	75909	3.1
16	Control Box (Complete)	AWTCB	75908	0.5
-	AWT Air/Water Tensioner (includes 2 each items 12, 13, & 14 and 1 each items 15 & 16)	AWT	75904	39.2
-	AWT Air/Water Tensioner w/o Control Box (includes 2 each items 12, 13, 14 & 1 each item 15)	AWTNCB	76069	34.2
-	AWT Air/Water Tensioner w/o Control Box, 1 side (includes 1 each items 12, 13, 14 & 15)	AWT-1S	76375	17.1

*Hardware Included

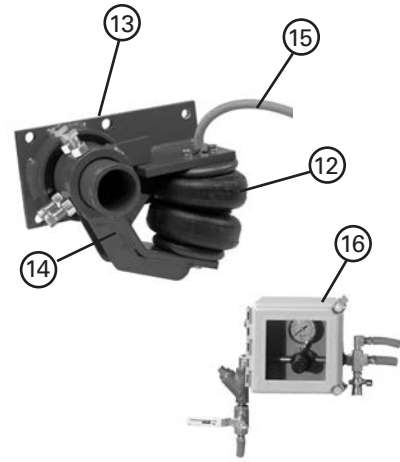

Stock items (non-shaded) refer to (*) for specific lead time, if not specified, standard lead time applies.

Non-stock items (shaded) please contact Flexco for dispatch options and lead times.

Replacement Parts List

Stainless Steel MMP Medium Mine-Duty Primary Cleaner

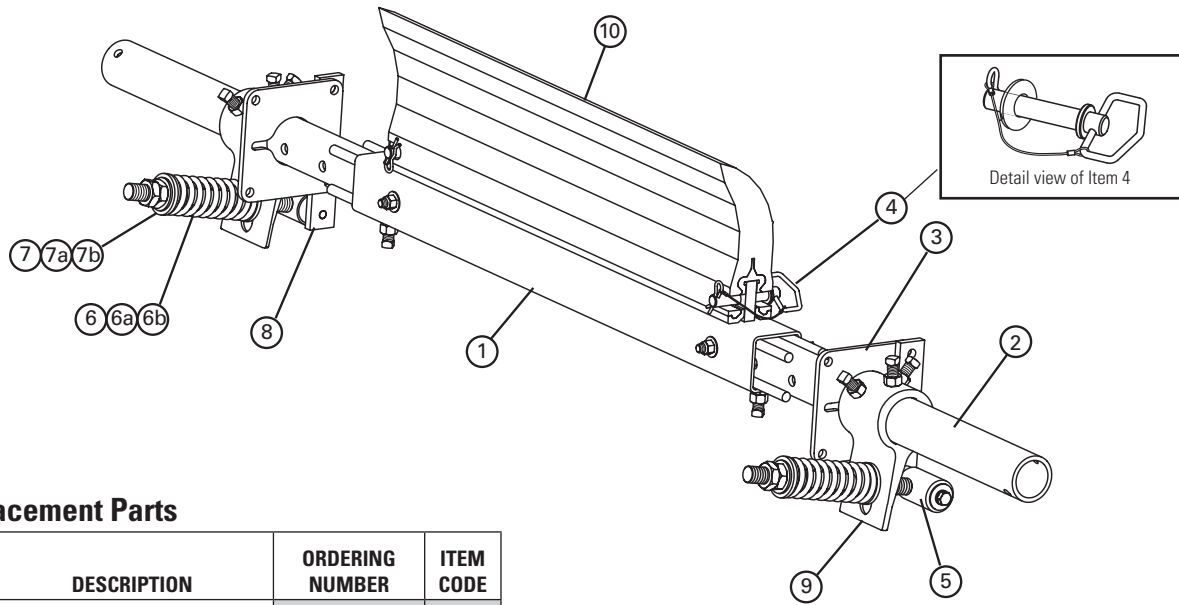

Replacement Parts

REF	DESCRIPTION	ORDERING NUMBER	ITEM CODE
1	600 mm SS Pole	MMPCP24-S/S	77590
	750 mm SS Pole	MMPCP30-S/S	77591
	900 mm SS Pole	MMPCP36-S/S	77592
	1050 mm SS Pole	MMPCP42-S/S	77593
	1200 mm SS Pole	MMPCP48-S/S	77594
	1350 mm SS Pole	MMPCP54-S/S	77595
	1500 mm SS Pole	MMPCP60-S/S	77596
	1800 mm SS Pole	MMPCP72-S/S	77597
	2100 mm SS Pole	MMPCP84-S/S	77598
2	SS Extender Pole Kit (2 ea.)	MHP-EP-S/S	77599
3	SS Mounting Plate Kit* (2 ea.)	MSPMPK-S/S	77582
4	SS Blade Pin Kit* (1 ea.)	MMPBPK-S/S	77600
5	SS Pivot Arm Kit* (1 ea.)	QMTPAK-S/S	77587
6	SS Tension Spring - Purple (1 ea.) for blades 600 mm	QMTS-P-S/S	77450
6a	SS Tension Spring - White (1 ea.) for blades 750 - 1200 mm	QSTS-W-S/S	77451
6b	SS Tension Spring - Gold (1 ea.) for blades 1350 - 1950 mm	QMTS-G-S/S	77452
7	Bushing Kit - Purple (2 ea.)	QMTBK-P	76097
7a	Bushing Kit - White (2 ea.)	QMTBK-W	76098
7b	Bushing Kit - Gold (2 ea.)	QMTBK-G	76540
8	SS Pivot Shaft Bracket Kit* (1 ea.)	QMTPSBK-S/S	77588
9	SS Torsion Arm Kit* (1 ea.)	PSTA-S/S	77442
-	SS QMT Spring Tensioner* - Purple (incl. 1 ea. Items 5, 6, 7, 8, & 9) for blades 450 - 600 mm	QMT-P-S/S	77584
-	SS QMT Spring Tensioner* - White (incl. 1 ea. Items 5, 6a, 7a, 8, & 9) for blades 750 - 1200 mm	QMT-W-S/S	77585
-	SS QMT Spring Tensioner* - Gold (incl. 1 ea. Items 5, 6b, 7b, 8, & 9) for blades 1350 - 1950 mm	QMT-G-S/S	77586

*Hardware Included

Replacement TuffShear™ Blades

REF	BLADE WIDTH mm	ORDERING NUMBER	ITEM CODE	WT. KG.
10	450	TRB18	76485	9.6
	600	TRB24	76486	12.7
	750	TRB30	76487	16.0
	900	TRB36	76488	19.1
	1050	TRB42	76489	22.3
	1200	TRB48	76490	25.5
	1350	TRB54	76491	28.6
	1500	TRB60	76492	31.8
	1650	TRB66	76493	35.0
	1800	TRB72	76494	38.2
	1950	TRB78	76697	41.4
	2100	TRB84	77047	44.5
	2400	TRB90	77048	47.6

Order blade width for your belt width's material path:
Belt Width Minus 152 mm, Belt Width Minus 305 mm, or
Belt Width Minus 457 mm.

Spring Tensioner Selection Chart

CLEANER BLADE WIDTH	76403 EST-P	76404 EST-S	76405 EST-B
TuffShear™ 450 - 600 mm	X		
TuffShear 750 - 1200 mm		X	
TuffShear 1350 - 1950 mm			X

Stock items (non-shaded) refer to (*) for specific lead time, if not specified, standard lead time applies.

Non-stock items (shaded) please contact Flexco for dispatch options and lead times.

U.S. Patent No. D482,508S

Specifications & Guidelines

MMP Medium Mine-Duty Primary Cleaner

Pole Length Specifications*

BELT WIDTH mm	MAX OVERALL POLE LENGTH mm	CENTRE POLE LENGTH mm	MAXIMUM CONVEYOR SPAN mm
600	1950	600	1650
750	2100	750	1800
900	2250	900	1950
1050	2400	1050	2100
1200	2550	1200	2250
1350	2700	1350	2400
1500	2850	1500	2550
1800	3150	1800	2850
2100	3450	2100	3150

* For special extra long pole length requirements a Pole Extender Kit (#76024) is available that provides 750 mm of extended pole length. Pole Diameter -73 mm

Clearance Guidelines for Installation

HORIZONTAL CLEARANCE REQUIRED mm	VERTICAL CLEARANCE REQUIRED mm
100	325

Spring Length Chart

with QMT Spring Tensioner

BLADE WIDTH mm	PURPLE SPRINGS mm	WHITE SPRINGS mm	GOLD SPRINGS mm
450	110	150	160
600	100	140	150
750	N/A	140	150
900	N/A	130	150
1050	N/A	130	140
1200	N/A	130	140
1350	N/A	120	140
1500	N/A	120	140
1650	N/A	N/A	130
1800	N/A	N/A	130
1950	N/A	N/A	130
2100	N/A	N/A	N/A
2250	N/A	N/A	N/A

Shading indicates preferred spring option

Specifications:

- Maximum Belt Speed Contact Flexco®
- Temperature Rating -35°C to 82°C
- Minimum Pulley Diameter..... 400 mm
- Usable Blade Wear Length..... 150 mm
- Blade Polyurethane (proprietary blend for abrasion resistance and long wear)
- Available for Belt Widths 600 to 2100 mm
Other sizes available upon request

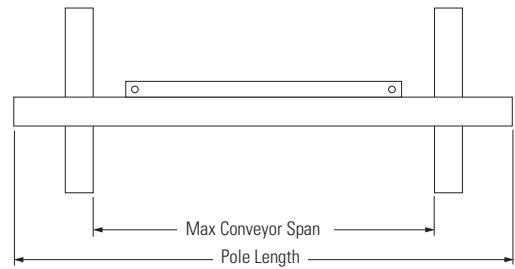

Pole Location Specs

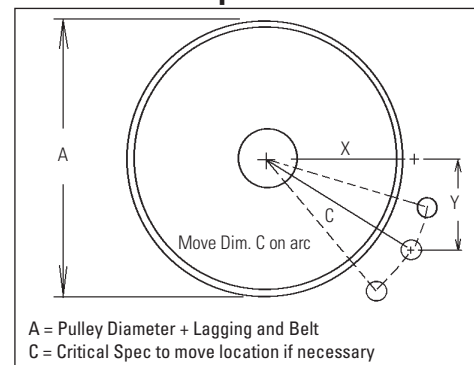

Pole Location Chart

A	X	Y	C
406	207	305	368
432	222	305	378
457	235	305	384
483	248	305	394
508	264	305	403
533	279	305	413
559	292	305	422
584	305	305	432
610	321	305	441
635	334	305	451
660	346	305	461
686	359	305	470
711	372	305	480
737	387	305	492
762	397	305	502
787	410	305	511
813	425	305	524
838	438	305	533
864	451	305	543
889	464	305	556
914	476	305	565
940	492	305	578
965	502	305	588
991	518	305	600
1016	527	305	610
1041	543	305	622
1067	552	305	632
1092	568	305	645
1118	578	305	654
1143	594	305	667
1168	607	305	679
1194	619	305	689
1219	632	305	702

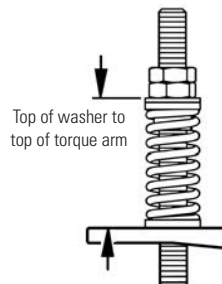
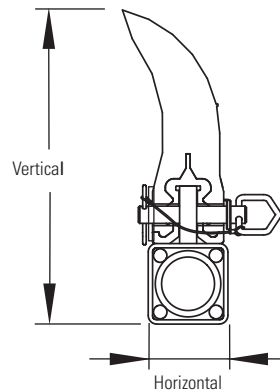

Product Ordering Information

Line Connections for Portable Air Tensioner

ORDERING NUMBER	ITEM CODE	WT. LBS.
PAT1	78684	13.0
PAT2	78685	13.0



PAT1 (Single)



PAT2 (Dual)

REF	DESCRIPTION	ORDERING NUMBER	ITEM CODE	WT. LBS.
1	Tank Label Kit	PATLK	78791	0.1
2	Tank Hose Kit (incl. 1 ea. 10' hose and 1' poly spiral wrap, 2 hose clamps)	PATHK	78794	1.5

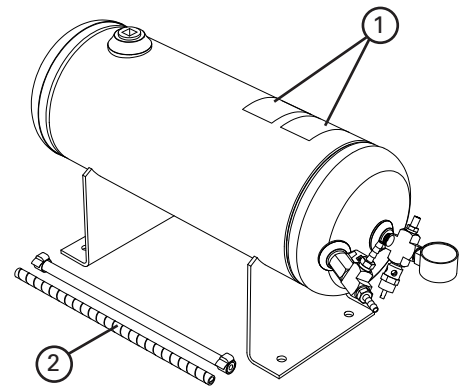

Product Notes:

- For use with PAT cleaner assemblies and PAT control box.
- Single for applications with one cleaner, double for applications with two cleaners.
- 150# pop-off valve for safe pressurizing/charging of Air Tank.
- ASME Construction.

Stock items (non-shaded) refer to (*) for specific lead time, if not specified, standard lead time applies.

Non-stock items (shaded) please contact Flexco for dispatch options and lead times.

Product Ordering Information

MHCP Heavy-Duty Cartridge Primary Cleaner

MHCP HD Cartridge Primary Cleaner with Spring Tensioner (PST)

BELT WIDTH mm	BLADE COVERAGE mm	ORDERING NUMBER	ITEM CODE	WT. KG.
600	450	MHCP-24S	75929	87.3
750	600	MHCP-30S	75930	94.2
900	750	MHCP-36S	75931	101.1
1050	900	MHCP-42S	75932	107.9
1200	1050	MHCP-48S	75933	114.8
1350	1200	MHCP-54S	75934	121.6
1500	1350	MHCP-60S	75935	128.5
1800	1650	MHCP-72S	75936	142.2
2100	1950	MHCP-84S	76800	165.9

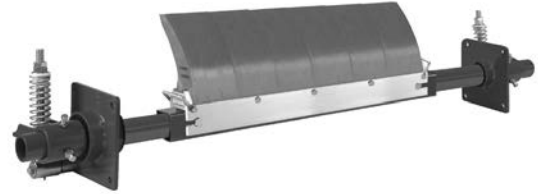

Mild Steel Model Pictured

MHCP HD Cartridge Primary Cleaner with Air/Water Tensioner (AWT)*

BELT WIDTH mm	BLADE COVERAGE mm	ORDERING NUMBER	ITEM CODE	WT. KG.
600	450	MHCP-24A	75937	87.4
750	600	MHCP-30A	75938	94.2
900	750	MHCP-36A	75939	101.1
1050	900	MHCP-42A	75940	107.9
1200	1050	MHCP-48A	75941	114.8
1350	1200	MHCP-54A	75942	121.6
1500	1350	MHCP-60A	75943	128.5
1800	1650	MHCP-72A	75944	142.2
2100	1950	MHCP-84A	76801	165.9



Mild Steel Model Pictured

Product Notes:

- Heavy-duty design with massive SuperShear™ blades for constant cleaning power on abusive beltlines.
- Blade width equals Belt Width minus 150 mm. Can be adjusted to belt's material path.
- Pole Length: Belt Width plus 1450 mm. For longer requirements see Mineliner® Installation Accessories - Pole Extender Kit .
- Tensioner Options: 1) PST Spring Tensioner for self-adjusting tensioning with easy retensioning adjustments; 2) AWT Air/Water Tensioner for automatic tensioning throughout the life of the blades.

Stock items (non-shaded) refer to (*) for specific lead time, if not specified, standard lead time applies.

Non-stock items (shaded) please contact Flexco for dispatch options and lead times.

Specifications & Guidelines

MHCP Heavy-Duty Cartridge Primary Cleaner

Telescoping Pole Length Specifications

CLEANER SIZE mm	MAX OVERALL POLE LENGTH ITEM CODE mm	CENTRE POLE LENGTH mm	MAXIMUM CONVEYOR SPAN mm
600	2050	700	1650
750	2200	850	1800
900	2350	1000	1950
1050	2500	1150	2100
1200	2650	1300	2250
1350	2800	1450	2400
1500	2950	1600	2550
1800	3250	1900	2850
2100	3550	2200	3150

Pole Diameter - 73 mm

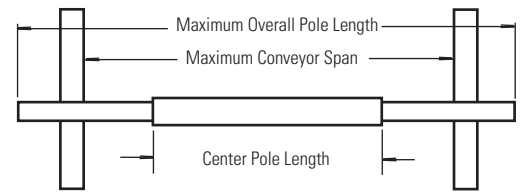

Pole Location Specs

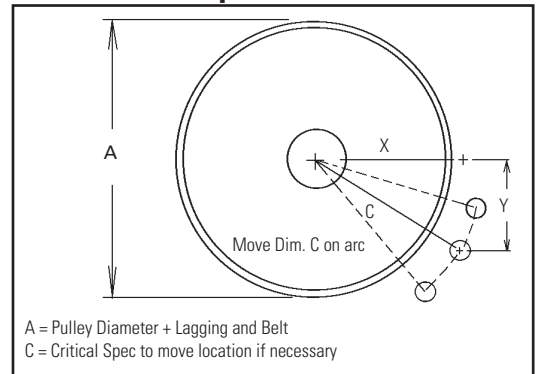

Clearance Guidelines for Installation

HORIZONTAL CLEARANCE REQUIRED mm	VERTICAL CLEARANCE REQUIRED mm
175	475

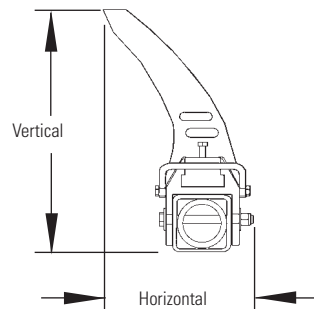

Spring Length Chart with PST Spring Tensioner

BLADE WIDTH mm	NO. OF BLADES	WHITE SPRINGS mm	SILVER SPRINGS mm
450	3	140	160
600	4	130	150
750	5	130	150
900	6	120	150
1050	7	110	150
1200	8	N/A	140
1350	9	N/A	140
1500	10	N/A	140
1650	11	N/A	140
1800	12	N/A	130
1950	13	N/A	130

Shading indicates preferred spring option
Spring tension is based on the number of blades on the cleaner, not the Belt Width.

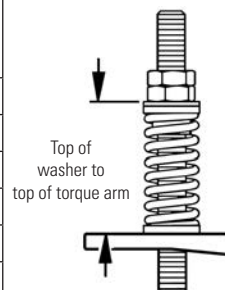

Air/Water Chart

BLADE WIDTH mm	BLADES	PSI
450	3	8#
600	4	10#
750	5	13#
900	6	15#
1050	7	18#
1200	8	20#
1350	9	23#
1500	10	25#
1650	11	28#
1950	12	31#

PSI setting is based on the number of blades on the cleaner, not the Belt Width.

Pole Location Chart

A	X	Y	C
508	254	365	445
533	267	365	451
559	279	365	461
584	292	365	467
610	305	365	476
635	318	365	483
660	330	365	492
686	343	365	502
711	356	365	511
737	368	365	518
762	381	365	527
787	394	365	537
813	406	365	546
838	419	365	556
864	432	365	565
889	445	365	575
914	457	365	584
940	470	365	594
965	483	365	607
991	495	365	616
1016	508	365	626
1041	521	365	635
1067	533	365	648
1092	546	365	657
1118	559	365	667
1143	572	365	679
1168	584	365	689
1194	591	365	699
1219	610	365	711

Specifications:

- Maximum Belt SpeedContact Flexco®
- Temperature Rating-35°C to 82°C
- Minimum Pulley Diameter.....400 mm
- Usable Blade Wear Length.....200 mm
- BladesPolyurethane (proprietary blend for abrasion resistance and long wear)
- Available for Belt Widths600 to 2100 mm
Other sizes available upon request.

Replacement Parts List

MHCP Heavy-Duty Cartridge Primary Cleaner

Replacement Parts List

REF	DESCRIPTION	ORDERING NUMBER	ITEM CODE	WT. KG.
1	600 mm Centre Pole*	MHP-CP600	75961	8.6
	750 mm Centre Pole*	MHP-CP750	75962	10.5
	900 mm Centre Pole*	MHP-CP900	75963	12.4
	1050 mm Centre Pole*	MHP-CP1050	75964	14.2
	1200 mm Centre Pole*	MHP-CP1200	75965	16.1
	1350 mm Centre Pole*	MHP-CP1400	75966	17.9
	1500 mm Centre Pole*	MHP-CP1500	75967	19.8
	1800 mm Centre Pole*	MHP-CP1800	75968	23.5
	2100 mm Centre Pole*	MHP-CP2100	76811	27.4
2	MHCP Extender Poles (2 ea.)	MHP-EP	76392	24.6
3	SuperShear™ Blade	SSRB	75978	3.0
	SuperShear™ FRAS Blade	SSFRB	78456	3.0
4	600 mm 2-Piece Blade Cartridge*	MHCP-2BC24	76638	6.0
	750 mm 2-Piece Blade Cartridge*	MHCP-2BC30	76639	8.0
	900 mm 2-Piece Blade Cartridge*	MHCP-2BC36	76640	10.0
	1050 mm 2-Piece Blade Cartridge*	MHCP-2BC42	76641	12.0
	1200 mm 2-Piece Blade Cartridge*	MHCP-2BC48	76642	14.0
	1350 mm 2-Piece Blade Cartridge*	MHCP-2BC54	76643	16.0
	1500 mm 2-Piece Blade Cartridge*	MHCP-2BC60	76644	18.0
	1800 mm 2-Piece Blade Cartridge*	MHCP-2BC72	76645	22.0
	2100 mm 2-Piece Blade Cartridge*	MHCP-2BC84	76812	25.7
5	MHCP Cartridge Handle*	MHCP-CH	76393	0.2
6	MHCP Cartridge Blade Stop*	MHCP-BS	76394	0.2



Blades Required per Belt Width

BELT WIDTH mm	BLADE COVERAGE mm	BLADES REQUIRED
600	450	3
750	600	4
900	750	5
1050	900	6
1200	1050	7
1350	1200	8
1500	1350	9
1800	1650	11
2100	1950	13

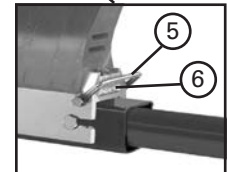

Blades and cartridges can be purchased separately (see chart at left) or preassembled as a Blade Cartridge Kit

PST Spring Tensioner Replacement Parts

REF	DESCRIPTION	ORDERING NUMBER	ITEM CODE	WT. KG.
7	Mounting Base* (1 ea.)	PMB	75895	10.1
8	Torque Arm* (1 ea.)	PSTA	75896	5.1
9	Torque Pivot Kit (1 ea.) (no spring)	PTPK	75897	3.2
10	Tension Spring - White (1 ea.) for belts 600-1200 mm	PSTS-W	75898	0.8
10a	Tension Spring - Silver (1 ea.) for belts 1350-2100 mm	PSTS-S	75899	1.4
11	Bushing Kit (2 ea.) (for White & Silver Tensioners)	QMTBK-W	76098	0.1
	PST Spring Tensioner* - White (includes 2 each items 7, 8, 9, 10 & 11) for belts 600-1200 mm	PST-W	75893	39.1
	PST Spring Tensioner* - Silver (includes 2 each items 7, 8, 9, 10a & 11) for belts 1350-2100 mm	PST-S	75894	39.2

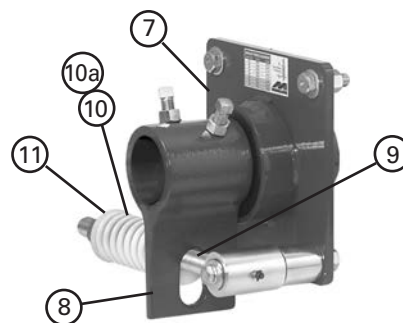

Air/Water Tensioner Replacement Parts

REF	DESCRIPTION	ORDERING NUMBER	ITEM CODE	WT. KG.
12	Air/Water Bag (1 ea.)	AWTB	75905	1.7
13	Mounting Base (1 ea.)	AWTMB	75906	10.4
14	Torque Arm* (1 ea.)	AWTA	75907	5.3
15	Hose Kit (15 M of hose and 6 hose clamps)	AWTHK	75909	3.1
16	Control Box (Complete)	AWTCB	75908	0.5
-	AWT Air/Water Tensioner (includes 2 each items 12, 13, & 14 and 1 each items 15 & 16)	AWT	75904	39.2
-	AWT Air/Water Tensioner w/o Control Box (includes 2 each items 12, 13, 14 & 1 each item 15)	AWTNCB	76069	34.2
-	AWT Air/Water Tensioner w/o Control Box, 1 side (includes 1 each items 12, 13, 14 & 15)	AWT-1S	76375	17.1

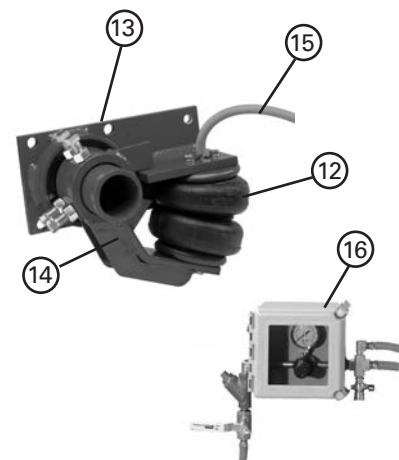

*Hardware Included

Stock items (non-shaded) refer to (*) for specific lead time, if not specified, standard lead time applies.

Non-stock items (shaded) please contact Flexco for dispatch options and lead times.

Product Ordering Information

MHCP Stainless Steel Heavy-Duty Cartridge Primary Cleaner

MHCP S/S HD Cartridge Primary Cleaner with Spring Tensioner (PST)

BELT WIDTH mm	ORDERING NUMBER	ITEM CODE	WT. KG.
600	MHCP-600S-S/S	61504	81.0
750	MHCP-750S-S/S	61505	89.4
900	MHCP-900S-S/S	61506	97.8
1050	MHCP-1050S-S/S	61507	108.1
1200	MHCP-1200S-S/S	61508	116.4
1350	MHCP-1350S-S/S	61509	124.8
1500	MHCP-1500S-S/S	61510	133.1
1650	MHCP-1650S-S/S	61511	141.4
1800	MHCP-1800S-S/S	61512	149.7
2100	MHCP-2100S-S/S	61513	166.7

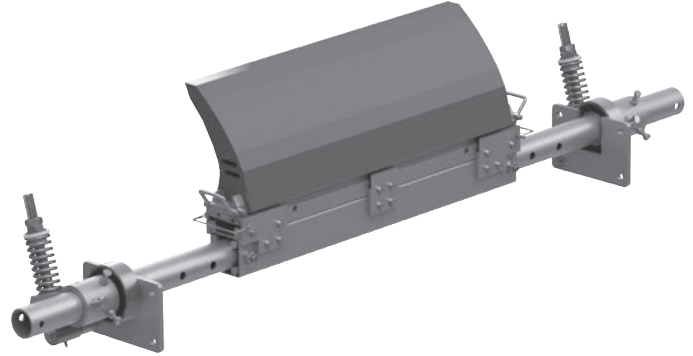

MHCP S/S FRAS HD Cartridge Primary Cleaner with Spring Tensioner (PST)

BELT WIDTH mm	ORDERING NUMBER	ITEM CODE	WT. KG.
600	MHCP-600S-S/S-FR	61624	81.0
750	MHCP-750S-S/S-FR	61625	89.4
900	MHCP-900S-S/S-FR	61626	97.8
1050	MHCP-1050S-S/S-FR	61627	108.1
1200	MHCP-1200S-S/S-FR	61628	116.4
1350	MHCP-1350S-S/S-FR	61629	124.8
1500	MHCP-1500S-S/S-FR	61630	133.1
1650	MHCP-1650S-S/S-FR	61631	141.4
1800	MHCP-1800S-S/S-FR	61632	149.7
2100	MHCP-2100S-S/S-FR	61633	166.7

Product Notes:

- Works with mechanical fasteners. The shock-absorbing tensioners and the force distributor vents in the blades allow mechanical splices, skived or unskived, to pass without damage to the splice or the cleaner and with minimal cleaning disruption..
- Complete cleaning system. When teamed with the MHS HD Secondary Cleaner, it makes up a system that delivers maximum cleaning power for the most abusive conveyor applications.
- Made for mining conveyors. Made from heavy-duty, corrosion-resistant steel, the MHCP is available in sizes for belt widths from 600 to 2100mm. Additional sizes are available upon request.
- Stainless steel. Corrosive environments wear on any component, but stainless steel can protect against that.

Stock items (non-shaded) refer to (*) for specific lead time, if not specified, standard lead time applies.

Non-stock items (shaded) please contact Flexco for dispatch options and lead times.

Specifications & Guidelines

MHCP Stainless Steel Heavy-Duty Cartridge Primary Cleaner

Telescoping Pole Length Specifications

Cleaner Size		Max Overall Pole Length		Centre Pole Length		Maximum Conveyor Span	
in.	mm	in.	mm	in.	mm	in.	mm
24	600	81	2020	20	511	65	1620
30	750	87	2173	27	663	71	1773
36	900	93	2325	33	815	77	1925
42	1050	99	2478	39	968	83	2078
48	1200	105	2630	45	1120	89	2230
54	1350	111	2783	51	1273	95	2383
60	1500	117	2935	57	1425	101	2535
66	1650	123	3087	63	1577	107	2687
72	1800	130	3240	69	1730	114	2840
84	2100	142	3545	81	2035	126	3145

Pole Diameter - 2-7/8" (73mm)

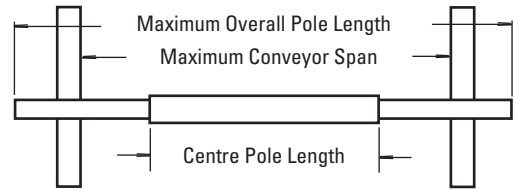

Clearance Guidelines for Installation

Horizontal Clearance Required		Vertical Clearance Required	
in.	mm	in.	mm
7	175	19	475

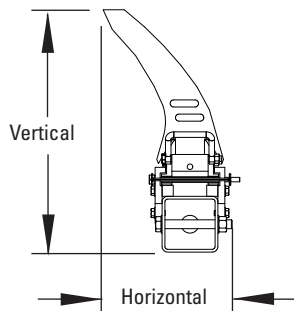

Spring Length Chart with PST Spring Tensioner

Blade Width	No. Of Blades	White Springs	Silver Springs
600	3	142	162
750	4	149	159
900	5	143	156
1050	6	140	156
1200	7	133	152
1350	8	N/A	149
1500	9	N/A	146
1650	10	N/A	146
1800	11	N/A	143
2100	13	N/A	140

Spring tension is based on the number of blades on the cleaner, not the belt width. Shading indicates preferred spring option.

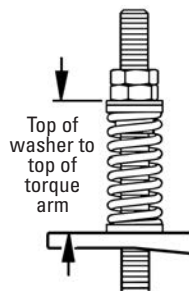

Pole Location Specs

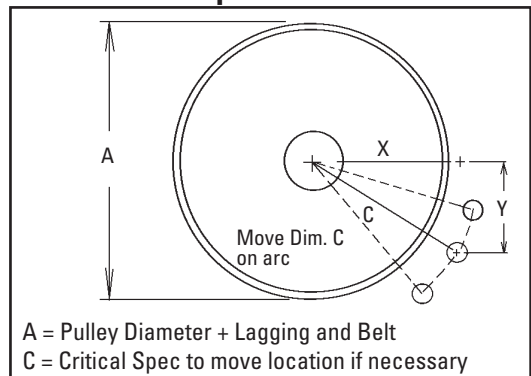

Pole Location Chart

A	X	C
500	229	473
525	242	479
550	254	486
575	267	492
600	279	499
625	292	506
650	304	514
675	317	521
700	329	529
725	342	537
750	354	545
775	367	553
800	379	561
825	392	570
850	404	578
875	417	587
900	429	596
925	442	605
950	454	614
975	467	624
1000	479	633
1025	492	643
1050	504	652
1075	517	662
1100	529	672
1125	542	682
1150	554	692
1175	567	702
1200	579	712

Specifications:

- Maximum Belt Speed6M/sec
- Temperature Rating-35°C to 82°C
- Minimum Pulley Diameter500mm
- Blade Height350mm
- Usable Blade Wear Length200mm
- BladesPolyurethane (proprietary blend for abrasion resistance and long wear).
- Available for Belt Widths.....600 to 2400mm.
Other sizes available upon request.

Replacement Parts List

MHCP Stainless Steel Heavy-Duty Cartridge Primary Cleaner

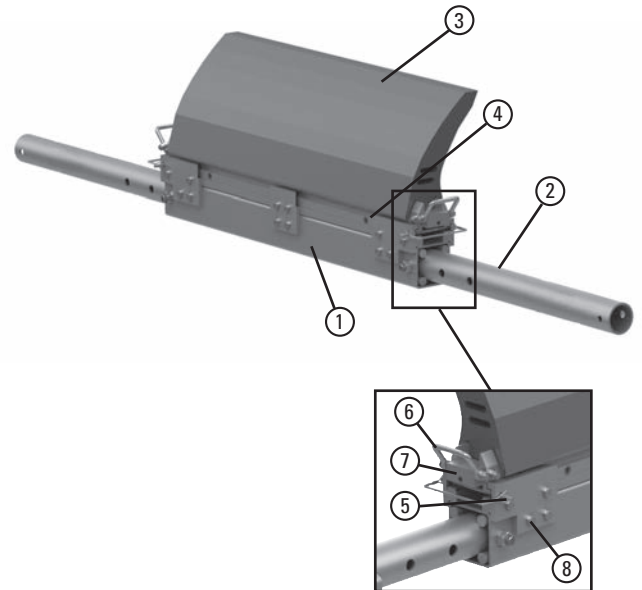

Replacement Parts

REF	DESCRIPTION	ORDERING NUMBER	ITEM CODE	WT. KG.
1	24" (600mm) Centre Pole*	MHCP-S/S-CP 600	61634	15.9
	30" (750mm) Centre Pole*	MHCP-S/S-CP 750	61525	19.1
	36" (900mm) Centre Pole*	MHCP-S/S-CP 900	61526	22.3
	42" (1050mm) Centre Pole*	MHCP-S/S-CP 1050	61527	27.4
	48" (1200mm) Centre Pole*	MHCP-S/S-CP 1200	61528	30.6
	54" (1350mm) Centre Pole*	MHCP-S/S-CP 1350	61529	33.8
	60" (1500mm) Centre Pole*	MHCP-S/S-CP 1500	61530	37.0
	66" (1650mm) Centre Pole*	MHCP-S/S-CP 1650	61531	40.2
	72" (1800mm) Centre Pole*	MHCP-S/S-CP 1800	61532	43.5
84" (2100mm) Centre Pole*	MHCP-S/S-CP 2100	61533	49.9	
2	MHCP S/S Extender Poles (2 ea.)	MHCP-SS/EP	61534	20.1
3	SuperShear™ Blade	SSRB	75978	3.0
3a	SuperShear™ FRAS Blade	SSFRB	78456	3.0
4	24" (600mm) Cartridge Kits*	MHCP-S/S-CK600	61535	9.3
	30" (750mm) Cartridge Kits*	MHCP-S/S-CK750	61536	11.7
	36" (900mm) Cartridge Kits*	MHCP-S/S-CK900	61537	14.0
	42" (1050mm) Cartridge Kits*	MHCP-S/S-CK1050	61538	16.3
	48" (1200mm) Cartridge Kits*	MHCP-S/S-CK1200	61539	18.6
	54" (1350mm) Cartridge Kits*	MHCP-S/S-CK1350	61540	21.0
	60" (1500mm) Cartridge Kits*	MHCP-S/S-CK1500	61541	23.3
	66" (1650mm) Cartridge Kits*	MHCP-S/S-CK1650	61542	25.6
	72" (1800mm) Cartridge Kits*	MHCP-S/S-CK1800	61543	28.0
84" (2100mm) Cartridge Kits*	MHCP-S/S-CK2100	61544	32.3	
5	MHCP S/S Cartridge Locking Pin	MHCP-S/S-CLP	61545	0.1
6	MHCP S/S Cartridge Handle*	MHCP-S/S-CH	61548	0.1
7	MHCP S/S Cartridge End Block*	MHCP-S/S-CEB	61549	0.5
8	MHCP S/S Cartridge Bolt Kit	MHCP-S/S-CBK	61550	0.1

*Hardware Included

Blades Required per Belt Width

Belt Width		Blades Required
in.	mm	
24	600	3
30	750	4
36	900	5
42	1050	6
48	1200	7
54	1350	8
60	1500	9
66	1650	10
72	1800	11
84	2100	13

Blades and cartridges can be purchased separately (see chart at left) or preassembled as a Blade Cartridge Kit.

PST Spring Tensioner Replacement Parts

REF	DESCRIPTION	ORDERING NUMBER	ITEM CODE	WT. KG.
9	Tension Spring - White (1 ea.) for belts 24" - 48" (600-1200mm)	PSTS-W	75898	0.8
9a	Tension Spring - Silver (1 ea.) for belts 54" - 96" (1350-2400mm)	PSTS-S	75899	1.4
10	Bushing Kit (2 ea.) for White & Silver Tensioners	QMTBK-W	76098	0.2
-	PST Spring Tensioner* - White (includes 2 ea.) for belts 600-1200mm (24" - 48")	MHCP-S/S-PSTW	61546	27.6
-	PST Spring Tensioner* - Silver (includes 2 ea.) for belts 1350-2400mm (54" - 96")	MHCP-S/S-PSTS	61547	27.7

*Hardware Included

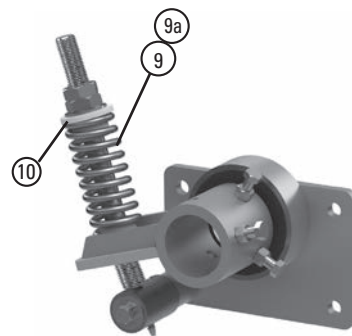

Product Ordering Information

H-Type® with XF-Tips Segmented Blade Primary Cleaner

H-Type® with XF-Tips Powder Coated

BELT WIDTH mm	HF-TIP SIZE	ORDERING NUMBER	ITEM CODE	WT. KG.
450	S	HXF450S	74659	35.0
450	M	HXF450M	74660	
600	S	HXF600S	74661	41.0
600	M	HXF600M	74662	
750	S	HXF750S	74663	42.0
750	M	HXF750M	74664	
900	S	HXF900S	74665	47.0
900	M	HXF900M	74666	
900	L	HXF900L	74667	
1050	S	HXF1050S	74668	60.0
1050	M	HXF1050M	74669	
1050	L	HXF1050L	74670	
1200	S	HXF1200S	74671	62.0
1200	M	HXF1200M	74672	
1200	L	HXF1200L	74673	
1500	M	HXF1500M	74677	75.0
1500	L	HXF1500L	74678	
1600	M	HXF1600M	73443	80.0
1600	L	HXF1600L	73444	
1800	M	HXFHD1800M	74681	105.0
1800	L	HXFHD1800L	74682	
2100	M	HXFHD2100M	74683	110.0
2100	L	HXFHD2100L	74684	
2400	M	HXFHD2400M	74685	120.0
2400	L	HXFHD2400L	74686	

Tips Required Per Cleaner Size

BELT WIDTH mm	BLADE COVERAGE mm	XF-TIPS REQUIRED
450	400	2
600	600	3
750	600	3
900	800	4
1050	1000	5
1200	1200	6
1500	1400	7
1600	1600	8
1800	1800	9
2100	2000	10
2400	2400	12

Product Notes:

- All cleaners supplied with dual tensioners.
- Also available with J-Bolt Side Assembly.
- Standard supply is non-FRAS.
- Specify when ordering FRAS.
- Specify arm size when ordering.
- For replacement parts refer to page 42.

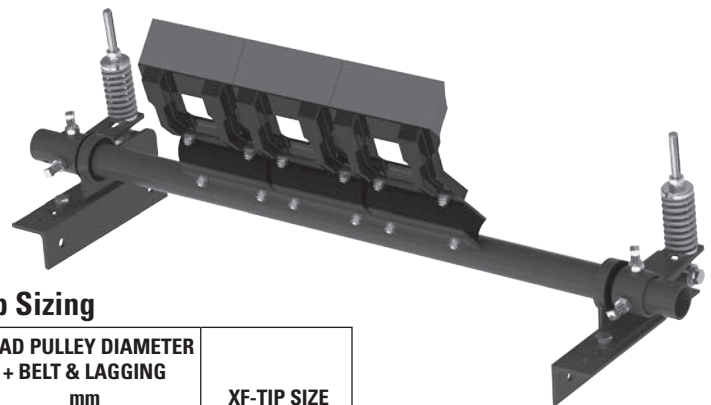

Tip Sizing

HEAD PULLEY DIAMETER + BELT & LAGGING mm	XF-TIP SIZE
up to 499	SS
500-799	S
800-999	M
1000-1200	L

Over 1200 mm - contact Flexco®.

Replacement XF8-Non-FRAS Tips

SIZE	ORDERING NUMBER	COLOUR	ITEM CODE	WT. KG.
SS	HXF8SS	Purple	74307	1.5
S	HXF8S	Purple	74689	1.7
M	HXF8M	Purple	74690	1.8
L	HXF8L	Purple	74691	2.0

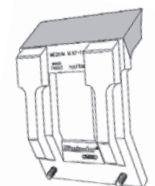

Replacement XF8-FRAS Tips

SIZE	ORDERING NUMBER	COLOUR	ITEM CODE	WT. KG.
SS	HXF8SS-Blue	Blue	77518	2.0
S	HXF8S-Blue	Blue	77519	2.0
M	HXF8M-Blue	Blue	77520	2.0
L	HXF8L-Blue	Blue	77521	2.5

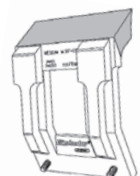

Replacement XF2-Non-FRAS Tips

SIZE	ORDERING NUMBER	COLOUR	ITEM CODE	WT. KG.
SS	HXF2-SS	Purple	75979	1.5
S	HXF2-S	Purple	75980	1.5
M	HXF2-M	Purple	75981	1.5
L	HXF2-L	Purple	75982	2.0

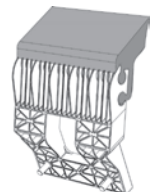

Specially formulated, long-wearing polyurethane blade tip.
Impact-resistant, reinforced nylon base for rigidity and minimal deflection.

Stock items (non-shaded) refer to (*) for specific lead time, if not specified, standard lead time applies.

Non-stock items (shaded) please contact Flexco for dispatch options and lead times.

Product Ordering Information

H-Type® with XF-Tips Segmented Blade Primary Cleaner Stainless Steel

H-Type® with XF-Tips Stainless Steel

BELT WIDTH mm	XF2-TIP SIZE	ORDERING NUMBER	ITEM CODE	WT. KG.
450	S	HXF450S-S/S	75266	35.0
450	M	HXF450M-S/S	75267	
600	S	HXF600S-S/S	75268	42.0
600	M	HXF600M-S/S	75269	
750	S	HXF750S-S/S	75270	43.0
750	M	HXF750M-S/S	75271	
900	S	HXF900S-S/S	75272	49.0
900	M	HXF900M-S/S	75273	
900	L	HXF900L-S/S	75274	
1050	S	HXF1050S-S/S	75275	62.0
1050	M	HXF1050M-S/S	75276	
1050	L	HXF1050L-S/S	75277	
1200	S	HXF1200S-S/S	75278	63.0
1200	M	HXF1200M-S/S	75279	
1200	L	HXF1200L-S/S	75280	
1500	M	HXF1500M-S/S	75281	77.0
1500	L	HXF1500L-S/S	75282	
1600	M	HXF1600M-S/S	75283	82.0
1600	L	HXF1600L-S/S	75284	
1800	M	HXFHD1800M-S/S	A1588	107.0
1800	L	HXFHD1800L-S/S	A1589	
2100	M	HXFHD2100M-S/S	A1590	112.0
2100	L	HXFHD2100L-S/S	A1591	
2400	M	HXFHD2400M-S/S	A1592	122.0
2400	L	HXFHD2400L-S/S	A1593	

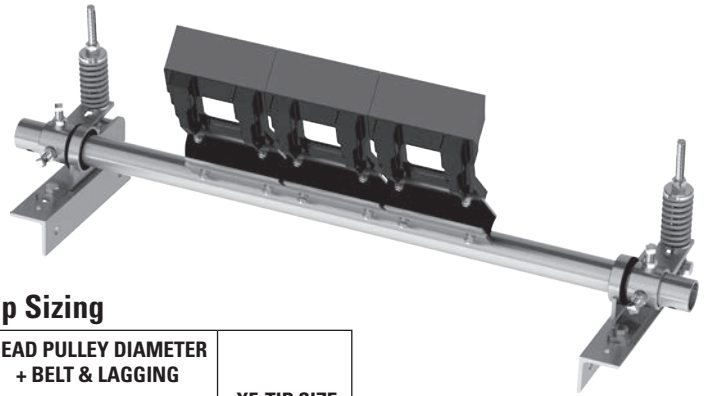

Tip Sizing

HEAD PULLEY DIAMETER + BELT & LAGGING mm	XF-TIP SIZE
up to 499	SS
500-799	S
800-999	M
1000-1200	L

Over 1200 mm- contact Flexco®.

Replacement XF8-Non-FRAS Tips

SIZE	ORDERING NUMBER	COLOUR	ITEM CODE	WT. KG.
SS	HXF8SS	Purple	74307	1.5
S	HXF8S	Purple	74689	1.7
M	HXF8M	Purple	74690	1.8
L	HXF8L	Purple	74691	2.0

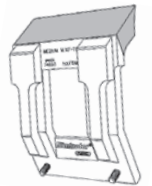

Replacement XF8-FRAS Tips

SIZE	ORDERING NUMBER	COLOUR	ITEM CODE	WT. KG.
SS	HXF8SS-Blue	Blue	77518	2.0
S	HXF8S-Blue	Blue	77519	2.0
M	HXF8M-Blue	Blue	77520	2.0
L	HXF8L-Blue	Blue	77521	2.5

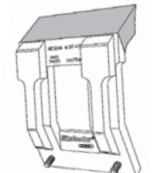

Replacement XF2-Non-FRAS Tips

SIZE	ORDERING NUMBER	COLOUR	ITEM CODE	WT. KG.
SS	HXF2-SS	Purple	75979	1.5
S	HXF2-S	Purple	75980	1.5
M	HXF2-M	Purple	75981	1.5
L	HXF2-L	Purple	75982	2.0

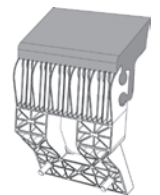

Specially formulated, long-wearing polyurethane blade tip. Impact-resistant, reinforced nylon base for rigidity and minimal deflection.

Tips Required Per Cleaner Size

BELT WIDTH mm	BLADE COVERAGE mm	XF-TIPS REQUIRED
450	400	2
600	600	3
750	600	3
900	800	4
1050	1000	5
1200	1200	6
1500	1400	7
1600	1600	8
1800	1800	9
2100	2000	10
2400	2400	12

Product Notes:

- All cleaners supplied with dual tensioners.
- Also available with J-Bolt Side Assembly.
- Standard supply is non-FRAS.
- Specify when ordering FRAS.
- Specify arm size when ordering.
- For replacement parts refer to page 42.

Stock items (non-shaded) refer to (*) for specific lead time, if not specified, standard lead time applies.

Non-stock items (shaded) please contact Flexco for dispatch options and lead times.

Product Ordering Information

H-Type® with V-Tips Segmented Blade Primary Cleaner

H-Type® with V-Tips*-Powder Coated

BELT WIDTH mm	SUSPENSION ARM SIZE	ORDERING NUMBER	ITEM CODE	WT. KG.
450	SS	HV450SS	73026	30.0
450	S	HV450S	73028	
450	M	HV450M	73019	
600	SS	HV600SS	73045	35.0
600	S	HV600S	73030	
600	M	HV600M	73173	
750	SS	HV750SS	73053	37.0
750	S	HV750S	73032	
750	M	HV750M	73174	
900	SS	HV900SS	73055	42.0
900	S	HV900S	73034	
900	M	HV900M	73175	
900	L	HV900L	73178	46.0
1050	SS	HV1050SS	73057	
1050	S	HV1050S	73056	
1050	M	HV1050M	73036	50.0
1050	L	HV1050L	73179	
1200	SS	HV1200SS	73059	
1200	S	HV1200S	73058	64.0
1200	M	HV1200M	73038	
1200	L	HV1200L	73180	
1500	M	HV1500M	73177	68.0
1500	L	HV1500L	73158	
1500	LL	HV1500LL	73215	
1600	M	HV1600M	73637	95.0
1600	L	HV1600L	73638	
1600	LL	HV1600LL	73639	
1800	M	HVHD1800M	74602	102.0
1800	L	HVHD1800L	74477	
1800	LL	HVHD1800LL	74478	
2100	M	HVHD2100M	74539	118.0
2100	L	HVHD2100L	74540	
2100	LL	HVHD2100LL	74541	
2400	M	HVHD2400M	74544	125.0
2400	L	HVHD2400L	74545	
2400	LL	HVHD2400LL	74546	
2600	M	HVHD2600M	A2396	133.0
2600	L	HVHD2600L	A2461	
2600	LL	HVHD2600LL	A2397	
3000	M	HVHD3000M	74591	133.0
3000	L	HVHD3000L	74592	
3000	LL	HVHD3000LL	74593	

Specify arm size when ordering.



Suspension Arm Size

HEAD PULLEY DIAMETER + BELT & LAGGING mm	SUSPENSION ARM SIZE
up to 499	SS
500-799	S
800-999	M
1000-1199	L
1200-1700	LL

Over 1700 mm—contact Flexco®.

Replacement V-Tips

ORDERING NUMBER	ITEM CODE	WT. KG.
HSA200	73489	0.5
HVPT-S/S	73631	1.2

Replacement Suspension Arms

SIZE	ORDERING NUMBER	ITEM CODE	WT. KG.
SS	HSA8SS	73047	0.9
S	HSA8S	73048	1.1
M	HSA8M	73049	1.3
L	HSA8L	73063	1.5
LL	HSA8LL	73064	1.7

Tips Required Per Cleaner Size

BELT WIDTH mm	BLADE COVERAGE mm	V-TIPS REQUIRED
450	400	2
600	600	3
750	600	3
900	800	4
1050	1000	5
1200	1200	6
1500	1350	7
1600	1600	8
1800	1800	9
2100	2000	10
2400	2400	12
2600	2600	13
3000	3000	15

Stock items (non-shaded) refer to (*) for specific lead time, if not specified, standard lead time applies.

Non-stock items (shaded) please contact Flexco for dispatch options and lead times.

Product Ordering Information

H-Type® with V-Tips Segmented Blade Primary Cleaner Stainless Steel

H-Type® with V-Tips*-Stainless Steel

BELT WIDTH mm	SUSPENSION ARM SIZE	ORDERING NUMBER	ITEM CODE	WT. KG.
450	SS	HV450SS-S/S	75293	30.0
450	S	HV450S-S/S	75294	
450	M	HV450M-S/S	75295	
600	SS	HV600SS-S/S	75296	36.0
600	S	HV600S-S/S	75297	
600	M	HV600M-S/S	75298	
750	SS	HV750SS-S/S	75299	38.0
750	S	HV750S-S/S	75300	
750	M	HV750M-S/S	75301	
900	SS	HV900SS-S/S	75302	43.0
900	S	HV900S-S/S	75303	
900	M	HV900M-S/S	75304	
900	L	HV900L-S/S	75305	47.0
1050	SS	HV1050SS-S/S	75306	
1050	S	HV1050S-S/S	75307	
1050	M	HV1050M-S/S	75308	50.0
1050	L	HV1050L-S/S	75309	
1200	SS	HV1200SS-S/S	75310	
1200	S	HV1200S-S/S	75311	64.0
1200	M	HV1200M-S/S	75312	
1200	L	HV1200L-S/S	75313	
1500	M	HV1500M-S/S	75314	68.0
1500	L	HV1500L-S/S	75315	
1500	LL	HV1500LL-S/S	75316	
1600	M	HV1600M-S/S	75317	98.0
1600	L	HV1600L-S/S	75318	
1600	LL	HV1600LL-S/S	75319	
1800	M	HVHD1800M-S/S	A1594	104.0
1800	L	HVHD1800L-S/S	A1595	
1800	LL	HVHD1800LL-S/S	A1596	
2100	M	HVHD2100M-S/S	A1597	121.0
2100	L	HVHD2100L-S/S	A1598	
2100	LL	HVHD2100LL-S/S	A1599	
2400	M	HVHD2400M-S/S	A1600	125.0
2400	L	HVHD2400L-S/S	A1601	
2400	LL	HVHD2400LL-S/S	A1602	
2600	M	HVHD2600M-S/S	A2462	135.0
2600	L	HVHD2600L-S/S	A2463	
2600	LL	HVHD2600LL-S/S	A2464	
3000	M	HVHD3000M-S/S	A2465	
3000	L	HVHD3000L-S/S	A2466	
3000	LL	HVHD3000LL-S/S	A2467	

Specify arm size when ordering.

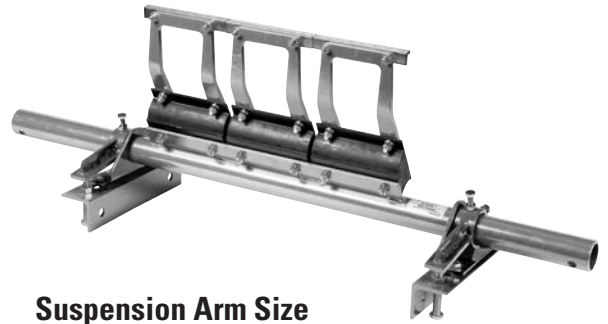

Suspension Arm Size

HEAD PULLEY DIAMETER + BELT & LAGGING mm	SUSPENSION ARM SIZE
up to 499	SS
500-799	S
800-999	M
1000-1199	L
1200-1700	LL

Over 1700 mm—contact Flexco®.

Replacement V-Tips

ORDERING NUMBER	ITEM CODE	WT. KG.
HVT8-S/S	75419	0.5
HVPT-S/S	73631	1.2

Replacement Suspension Arms

SIZE	ORDERING NUMBER	ITEM CODE	WT. KG.
SSS	HSA8SSS	75565	0.7
SS	HSA8SS-S/S	73771	0.9
S	HSA8S-S/S	73772	1.1
M	HSA8M-S/S	73773	1.3
L	HSA8L-S/S	73774	1.5
LL	HSA8LL-S/S	74033	1.7

Tips Required Per Cleaner Size

BELT WIDTH mm	BLADE COVERAGE mm	V-TIPS REQUIRED
450	400	2
600	600	3
750	600	3
900	800	4
1050	1000	5
1200	1200	6
1500	1400	7
1600	1600	8
1800	1800	9
2100	2000	10
2400	2400	12
2600	2600	13
3000	3000	15

Stock items (non-shaded) refer to (*) for specific lead time, if not specified, standard lead time applies.

Non-stock items (shaded) please contact Flexco for dispatch options and lead times.

Product Ordering Information

H-Type® with V-Tips and PCSTensioner Segmented Blade Primary Cleaner

H-Type® with V-Tips*-Powder Coated

BELT WIDTH mm	SUSPENSION ARM SIZE	ORDERING NUMBER	ITEM CODE	WT. KG.
450	SS	HV450SS-PCST	63936	36.8
450	S	HV450S-PCST	63937	
450	M	HV450M-PCST	63938	
600	SS	HV600SS-PCST	63939	41.8
600	S	HV600S-PCST	63940	
600	M	HV600M-PCST	63941	
750	SS	HV750SS-PCST	63942	43.8
750	S	HV750S-PCST	63943	
750	M	HV750M-PCST	63944	
900	SS	HV900SS-PCST	63945	48.8
900	S	HV900S-PCST	63946	
900	M	HV900M-PCST	63947	
900	L	HV900L-PCST	63948	52.8
1050	SS	HV1050SS-PCST	64045	
1050	S	HV1050S-PCST	63950	
1050	M	HV1050M-PCST	63951	56.8
1050	L	HV1050L-PCST	63952	
1200	SS	HV1200SS-PCST	63953	
1200	S	HV1200S-PCST	63954	70.8
1200	M	HV1200M-PCST	63955	
1200	L	HV1200L-PCST	63956	
1500	M	HV1500M-PCST	63957	74.8
1500	L	HV1500L-PCST	63958	
1500	LL	HV1500LL-PCST	63959	
1600	M	HV1600M-PCST	63960	101.8
1600	L	HV1600L-PCST	63961	
1600	LL	HV1600LL-PCST	63962	
1800	M	HV1800M-PCST	63963	108.8
1800	L	HV1800L-PCST	63964	
1800	LL	HV1800LL-PCST	63965	
2100	M	HV2100M-PCST	63966	125.0
2100	L	HV2100L-PCST	63967	
2100	LL	HV2100LL-PCST	63968	
2400	M	HV2400M-PCST	63969	132.0
2400	L	HV2400L-PCST	63970	
2400	LL	HV2400LL-PCST	63971	
2600	M	HV2600M-PCST	63972	140.0
2600	L	HV2600L-PCST	63973	
2600	LL	HV2600LL-PCST	63974	
3000	M	HV3000M-PCST	63975	
3000	L	HV3000L-PCST	63976	
3000	LL	HV3000LL-PCST	63977	

Specify arm size when ordering.

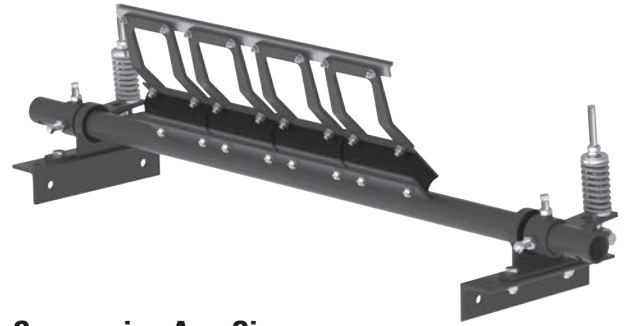

Suspension Arm Size

HEAD PULLEY DIAMETER + BELT & LAGGING mm	SUSPENSION ARM SIZE
up to 499	SS
500-799	S
800-999	M
1000-1199	L
1200-1700	LL

Over 1700 mm—contact Flexco®.

Replacement V-Tips

ORDERING NUMBER	ITEM CODE	WT. KG.
HSA200	73489	0.5
HVPT-S/S	73631	1.2

Replacement Suspension Arms

SIZE	ORDERING NUMBER	ITEM CODE	WT. KG.
SS	HSA8SS	73047	0.9
S	HSA8S	73048	1.1
M	HSA8M	73049	1.3
L	HSA8L	73063	1.5
LL	HSA8LL	73064	1.7

Tips Required Per Cleaner Size

BELT WIDTH mm	BLADE COVERAGE mm	V-TIPS REQUIRED
450	400	2
600	600	3
750	600	3
900	800	4
1050	1000	5
1200	1200	6
1500	1350	7
1600	1600	8
1800	1800	9
2100	2000	10
2400	2400	12
2600	2600	13
3000	3000	15

Stock items (non-shaded) refer to (*) for specific lead time, if not specified, standard lead time applies.

Non-stock items (shaded) please contact Flexco for dispatch options and lead times.

Product Ordering Information

H-Type® with V-Tips and PCSTensioner Stainless Steel

H-Type® with V-Tips*-Stainless Steel

BELT WIDTH mm	SUSPENSION ARM SIZE	ORDERING NUMBER	ITEM CODE	WT. KG.
450	SS	HV450SS-PCST-S/S	63978	30.0
450	S	HV450S-PCST-S/S	63979	
450	M	HV450M-PCST-S/S	63980	
600	SS	HV600SS-PCST-S/S	63981	36.0
600	S	HV600S-PCST-S/S	63982	
600	M	HV600M-PCST-S/S	63983	
750	SS	HV750SS-PCST-S/S	63984	38.0
750	S	HV750S-PCST-S/S	63985	
750	M	HV750M-PCST-S/S	63986	
900	SS	HV900SS-PCST-S/S	63987	43.0
900	S	HV900S-PCST-S/S	63988	
900	M	HV900M-PCST-S/S	63989	
900	L	HV900L-PCST-S/S	63990	
1050	SS	HV1050SS-PCST-S/S	63991	47.0
1050	S	HV1050S-PCST-S/S	63992	
1050	M	HV1050M-PCST-S/S	63993	
1050	L	HV1050L-PCST-S/S	63994	
1200	SS	HV1200SS-PCST-S/S	63995	50.0
1200	S	HV1200S-PCST-S/S	63996	
1200	M	HV1200M-PCST-S/S	63997	
1200	L	HV1200L-PCST-S/S	63998	
1500	M	HV1500M-PCST-S/S	63999	64.0
1500	L	HV1500L-PCST-S/S	64000	
1500	LL	HV1500LL-PCST-S/S	64001	
1600	M	HV1600M-PCST-S/S	64002	68.0
1600	L	HV1600L-PCST-S/S	64003	
1600	LL	HV1600LL-PCST-S/S	64004	
1800	M	HV1800M-PCST-S/S	64005	98.0
1800	L	HV1800L-PCST-S/S	64006	
1800	LL	HV1800LL-PCST-S/S	64007	
2100	M	HV2100M-PCST-S/S	64008	104.0
2100	L	HV2100L-PCST-S/S	64009	
2100	LL	HV2100LL-PCST-S/S	64010	
2400	M	HV2400M-PCST-S/S	64011	121.0
2400	L	HV2400L-PCST-S/S	64012	
2400	LL	HV2400LL-PCST-S/S	64013	
2600	M	HV2600M-PCST-S/S	64014	125.0
2600	L	HV2600L-PCST-S/S	64015	
2600	LL	HV2600LL-PCST-S/S	64016	
3000	M	HV3000M-PCST-S/S	64017	135.0
3000	L	HV3000L-PCST-S/S	64018	
3000	LL	HV3000LL-PCST-S/S	64019	

Specify arm size when ordering.

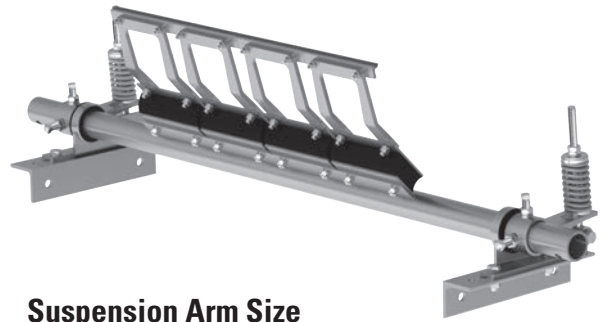

Suspension Arm Size

HEAD PULLEY DIAMETER + BELT & LAGGING mm	SUSPENSION ARM SIZE
up to 499	SS
500-799	S
800-999	M
1000-1199	L
1200-1700	LL

Over 1700 mm—contact Flexco®.

Replacement V-Tips

ORDERING NUMBER	ITEM CODE	WT. KG.
HVT8-S/S	75419	0.5
HVPT-S/S	73631	1.2

Replacement Suspension Arms

SIZE	ORDERING NUMBER	ITEM CODE	WT. KG.
SSS	HSA8SSS	75565	0.7
SS	HSA8SS-S/S	73771	0.9
S	HSA8S-S/S	73772	1.1
M	HSA8M-S/S	73773	1.3
L	HSA8L-S/S	73774	1.5
LL	HSA8LL-S/S	74033	1.7

Tips Required Per Cleaner Size

BELT WIDTH mm	BLADE COVERAGE mm	V-TIPS REQUIRED
450	400	2
600	600	3
750	600	3
900	800	4
1050	1000	5
1200	1200	6
1500	1400	7
1600	1600	8
1800	1800	9
2100	2000	10
2400	2400	12
2600	2600	13
3000	3000	15

Stock items (non-shaded) refer to (*) for specific lead time, if not specified, standard lead time applies.

Non-stock items (shaded) please contact Flexco for dispatch options and lead times.

Replacement Parts List

H-Type® Segmented Blade Primary Cleaners

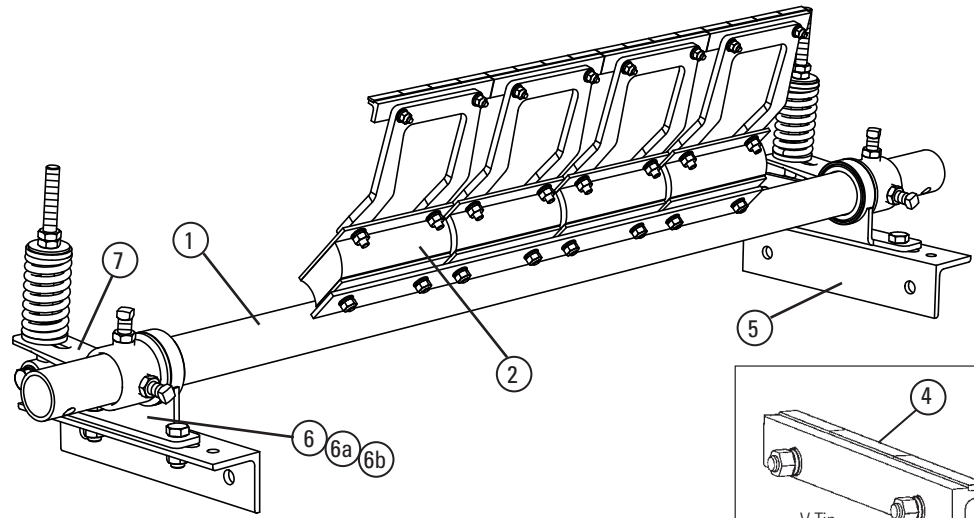
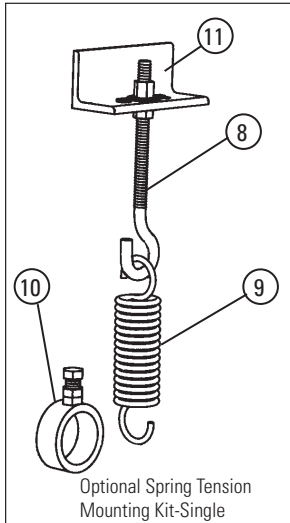

Replacement Parts

REF	DESCRIPTION	BELT WIDTH	POLE LENGTH (MM)	POWDER COATED			STAINLESS STEEL	
				ORDERING NUMBER	ITEM CODE	WT. KG.	ORDERING NUMBER	ITEM CODE
1	H-Type® Pole Standard-60 mm Pole Diameter	450	1250	HP450	73027	10.0	HP450-S/S	75373
		600	1350	HP600	73029	11.0	HP600-S/S	75374
		750	1500	HP750	73031	13.0	HP750-S/S	75375
		900	1650	HP900	73033	15.0	HP900-S/S	75376
		1050	1800	HP1050	73035	20.0	HP1050-S/S	75377
	H-Type Pole Standard-73 mm Pole Diameter	1200	1950	HP1200	73037	22.0	HP1200-S/S	75378
		1500	2350	HP1500	73066	24.0	HP1500-S/S	75379
	H-Type Pole Heavy-Duty-73 mm Pole Diameter Braced and Gusseted	1600	2450	HP1600	73739	27.0	HP1600-S/S	75380
		1800	2650	HPHD1800	74601	34.0	HPHD1800-S/S	A2063
2000		2950	HPHD2000	74547	39.0	HPHD2000-S/S	A1783	
	2400	3250	HPHD2400	74548	43.5	HPHD2400-S/S	A2590	
2	Cushion			HSA	73486	2.0	HVC-S/S	73494
	Heavy-Duty Cushion			HSHD	73483	2.0	HSHD-S/S	76467
-	H Polyshield (Not shown)			HPS8	73050	1.0	HSTSS	61173
4	V-Tip			HSA200	73489	0.5	HVT8-S/S	75419
							HVPT-S/S	73631
SIDE MOUNTING ASSEMBLY COMPONENTS- TO SUIT 60 mm								
5	H Mounting Bracket			HDMRK	74582	2.0	HDMRK-S/S	76245
6	H Bearing			HBRK	73068	1.5	HBRK-S/S	75422
6a	H Poly Bush 60mm			UNB60	61369	0.1		
6b	H Poly Bush 73mm			UNB73	A2671	0.1		
7	H Adjusting Arm			HARK	73069	1.5	HARK-S/S	75423
8	J-Bolt			STJK	74417	1.0		
9	Tension Spring			STTS	74419	1.0		
10	Spring Tensioner Collar			STCK	74506	1.0	STCK-S/S	75425
11	Spring Tensioner J-Bolt Mount			STJM	74775	1.0	STJM-S/S	75426
-	Spring Tension Kit-Dual (incl. STJK, STTS, STCK, STJM - 2 ea.)			STKD	74504	5.0	STKD-S/S	75427
-	H Mounting Kit- Dual (incl. HDMRK, HBRK, HARK - 2 ea.)			HMK	73054	11.0	HMK-S/S	75424
-	Black Compression Spring Side Assembly 60mm			HCSTK-60-B	62747	11.0	HCSTK-60-B-S/S	62748
-	Gold Compression Spring Side Assembly 60mm			HCSTK-60-G	62741	11.0	HCSTK-60-G-S/S	62742
SIDE MOUNTING ASSEMBLY COMPONENTS- TO SUIT 73 mm								
5	H Mounting Bracket			HDMRK	74582	3.0	HDMRK-S/S	76245
6	H Bearing			HBRKX	74549	2.0	HBRKX-S/S	76246
7	H Adjusting Arm			HDARK	74550	2.0	HDARK-S/S	76247
8	J-Bolt			STJK	74417	1.0		
9	Tension Spring			UTS	74420	1.0		
10	Spring Tensioner Collar			HDCK	74490	1.0	HDSTCK-S/S	A2189
11	Spring Tensioner J-Bolt Mount			STJM	74775	1.0	STJM-S/S	75426
-	Spring Tension Kit-Dual (incl. STJK, UTS, HDCK, STJM - 2 ea.)			HDSTKD	A2518	5.0	HDSTKD-S/S	A2519
-	H Mounting Kit- Dual (incl. HDMRK, HBRKX, HDARK - 2 ea.)			HDMK	74551	14.0	HDMK-S/S	76248
-	Black Compression Spring Side Assembly (to 1600 belt width max)			H73CSK-B	62749	17.8	H73CSK-B-S/S	62750
-	Gold Compression Spring Side Assembly (to 2400 belt width max)			H73CSK-G	62743	17.8	H73CSK-G-S/S	62744

Product Ordering Information

H-Type ESAC (Mild Steel) HD Primary Cleaner with Enhanced Service Advantage Cartridge™

Powder Coated H-Type® ESAC with V-Tips

TIP WIDTH	ARM SIZE	ORDERING NUMBER	ITEM CODE	Wght. KG.
Single Cartridge				
600	CS	HV-600-SAC-CS	62515	74.2
	CM	HV-600-SAC-CM	62516	74.9
	CL	HV-600-SAC-CL	62517	75.3
800	CS	HV-800-SAC-CS	62518	86.5
	CM	HV-800-SAC-CM	62519	87.5
	CL	HV-800-SAC-CL	62520	88.1
1000	CS	HV-1000-SAC-CS	62521	94.9
	CM	HV-1000-SAC-CM	62522	96.2
	CL	HV-1000-SAC-CL	62523	96.9
1200	CS	HV-1200-SAC-CS	62524	103.3
	CM	HV-1200-SAC-CM	62525	104.7
	CL	HV-1200-SAC-CL	62526	105.6
1400	CS	HV-1400-SAC-CS	62527	115.9
	CM	HV-1400-SAC-CM	62528	117.5
	CL	HV-1400-SAC-CL	62529	118.6
1600	CM	HV-1600-SAC-CM	62530	130.0
	CL	HV-1600-SAC-CL	62531	131.3
	CLL	HV-1600-SAC-CLL	62532	135.2
1800	CM	HV-1800-SAC-CM	62533	137.2
	CL	HV-1800-SAC-CL	62534	138.5
	CLL	HV-1800-SAC-CLL	62535	142.8
Dual Cartridge				
1200	CS	HV-1200-2SAC-CS	62557	128.7
	CM	HV-1200-2SAC-CM	62558	130.3
	CL	HV-1200-2SAC-CL	62559	131.2
	CLL	HV-1200-2SAC-CLL	62560	134.1
1400	CS	HV-1400-2SAC-CS	62561	137.4
	CM	HV-1400-2SAC-CM	62562	139.0
	CL	HV-1400-2SAC-CL	62563	140.1
	CLL	HV-1400-2SAC-CLL	62564	143.4
1600	CM	HV-1600-2SAC-CM	62565	147.9
	CL	HV-1600-2SAC-CL	62566	149.1
	CLL	HV-1600-2SAC-CLL	62567	152.9
1800	CM	HV-1800-2SAC-CM	62568	159.5
	CL	HV-1800-2SAC-CL	62569	160.9
	CLL	HV-1800-2SAC-CLL	62570	163.8
2000	CM	HV-2000-2SAC-CM	62571	169.2
	CL	HV-2000-2SAC-CL	62572	170.7
	CLL	HV-2000-2SAC-CLL	62573	174.0
2200	CM	HV-2200-2SAC-CM	62574	182.4
	CL	HV-2200-2SAC-CL	62575	184.1
	CLL	HV-2200-2SAC-CLL	62576	187.7
2400	CM	HV-2400-2SAC-CM	62577	187.5
	CL	HV-2400-2SAC-CL	62578	189.3
	CLL	HV-2400-2SAC-CLL	62579	193.3
2600	CM	HV-2600-2SAC-CM	62580	211.2
	CL	HV-2600-2SAC-CL	62581	213.2
	CLL	HV-2600-2SAC-CLL	62582	217.4
2800	CM	HV-2800-2SAC-CM	62583	220.9
	CL	HV-2800-2SAC-CL	62584	223.0
	CLL	HV-2800-2SAC-CLL	62585	227.7
3000	CM	HV-3000-2SAC-CM	62586	230.0
	CL	HV-3000-2SAC-CL	62587	232.3
	CLL	HV-3000-2SAC-CLL	62588	237.2

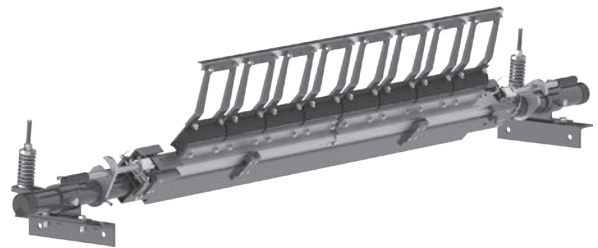

H-Type ESAC Dual HD Primary Cleaner

Replacement V-Tips

ORDERING NUMBER	ITEM CODE	WT. KG.
HSA200	73489	0.5

Replacement Suspension Arms

SIZE	ORDERING NUMBER	ITEM CODE	WT. KG.
CS	HSA8CS	62505	1.1
CM	HSA8CM	62506	1.3
CL	HSA8CL	62507	1.5
CLL	HSA8CLL	62508	1.7

Suspension Arm Size

HEAD PULLEY DIAMETER + BELT & LAGGING mm	SUSPENSION ARM SIZE
500-799	CS
800-999	CM
1000-1199	CL
1200-1700	CLL

Over 1700mm - contact Flexco

Tips required per cleaner size

BELT WIDTH mm	BELT COVERAGE mm	V-TIPS REQUIRED
600	600	3
800	800	4
1000	1000	5
1200	1200	6
1400	1400	7
1600	1600	8
1800	1800	9
2000	2000	10
2200	2200	11
2400	2400	12
2600	2600	13
2800	2800	14
3000	3000	15

Stock items (non-shaded) refer to (*) for specific lead time, if not specified, standard lead time applies.

Non-stock items (shaded) please contact Flexco for dispatch options and lead times.

Product Ordering Information

H-Type ESAC (Mild Steel) HD Primary Cleaner with Enhanced Service Advantage Cartridge™

H-Type ESAC Mild Steel Replacement Cartridge Kits with V-Tips

TIP WIDTH	ARM SIZE	ORDERING NUMBER	ITEM CODE	Wght. KG.
Single Cartridge Kits				
600	CS	H-CARK-600-CS	62536	23.2
	CM	H-CARK-600-CM	62537	24.0
	CL	H-CARK-600-CL	62538	24.5
800	CS	H-CARK-800-CS	62539	30.3
	CM	H-CARK-800-CM	62540	31.3
	CL	H-CARK-800-CL	62541	31.9
1000	CS	H-CARK-1000-CS	62542	36.1
	CM	H-CARK-1000-CM	62543	37.4
	CL	H-CARK-1000-CL	62544	38.2
1200	CS	H-CARK-1200-CS	62545	41.4
	CM	H-CARK-1200-CM	62546	43.3
	CL	H-CARK-1200-CL	62547	44.2
1400	CS	H-CARK-1400-CS	62548	49.0
	CM	H-CARK-1400-CM	62549	50.8
	CL	H-CARK-1400-CL	62550	51.9
1600	CM	H-CARK-1600-CS	62551	58.1
	CL	H-CARK-1600-CM	62552	59.3
	CLL	H-CARK-1600-CL	62553	63.1
1800	CM	H-CARK-1800-CS	62554	66.2
	CL	H-CARK-1800-CM	62555	67.6
	CLL	H-CARK-1800-CL	62556	71.9
Dual Cartridge Kits				
1200	CS	H-CARK2-1200-CS	62599	46.2
	CM	H-CARK2-1200-CM	62600	47.8
	CL	H-CARK2-1200-CL	62601	48.7
	CLL	H-CARK2-1200-CLL	62602	51.6
1400	CS	H-CARK2-1400-CS	62603	51.8
	CM	H-CARK2-1400-CM	62604	53.6
	CL	H-CARK2-1400-CL	62605	54.6
	CLL	H-CARK2-1400-CLL	62606	58.0
1600	CM	H-CARK2-1600-CM	62607	59.4
	CL	H-CARK2-1600-CL	62608	60.6
	CLL	H-CARK2-1600-CLL	62609	64.4
1800	CM	H-CARK2-1800-CM	62610	68.1
	CL	H-CARK2-1800-CL	62611	69.4
	CLL	H-CARK2-1800-CLL	62612	73.8
2000	CM	H-CARK2-2000-CM	62613	74.8
	CL	H-CARK2-2000-CL	62614	76.3
	CLL	H-CARK2-2000-CLL	62615	81.1
2200	CM	H-CARK2-2200-CM	62616	82.1
	CL	H-CARK2-2200-CL	62617	83.7
	CLL	H-CARK2-2200-CLL	62618	89.0
2400	CM	H-CARK2-2400-CM	62619	87.1
	CL	H-CARK2-2400-CL	62620	88.9
	CLL	H-CARK2-2400-CLL	62621	94.7
2600	CM	H-CARK2-2600-CM	62622	95.7
	CL	H-CARK2-2600-CL	62623	97.7
	CLL	H-CARK2-2600-CLL	62624	103.9
2800	CM	H-CARK2-2800-CM	62625	102.2
	CL	H-CARK2-2800-CL	62626	104.3
	CLL	H-CARK2-2800-CLL	62627	111.0
3000	CM	H-CARK2-3000-CM	62628	107.7
	CL	H-CARK2-3000-CL	62629	110.0
	CLL	H-CARK2-3000-CLL	62630	117.2

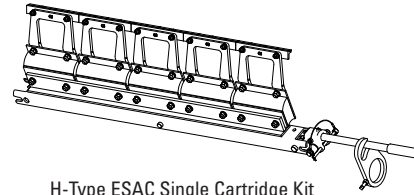

H-Type ESAC Single Cartridge Kit

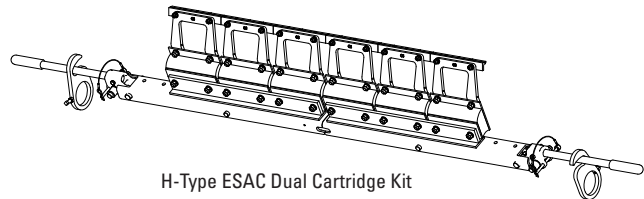

H-Type ESAC Dual Cartridge Kit

Stock items (non-shaded) refer to (*) for specific lead time, if not specified, standard lead time applies.

Non-stock items (shaded) please contact Flexco for dispatch options and lead times.

Product Ordering Information

H-Type ESAC (Stainless Steel) HD Primary Cleaner with Enhanced Service Advantage Cartridge™

Stainless Steel H-Type® ESAC with V-Tips

TIP WIDTH	ARM SIZE	ORDERING NUMBER	ITEM CODE	Wght. KG.
Single Cartridge				
600	CS	HV-600-SAC-CS-S/S	62631	74.2
	CM	HV-600-SAC-CM-S/S	62632	74.9
	CL	HV-600-SAC-CL-S/S	62633	75.3
800	CS	HV-800-SAC-CS-S/S	62634	86.5
	CM	HV-800-SAC-CM-S/S	62635	87.5
	CL	HV-800-SAC-CL-S/S	62636	88.1
1000	CS	HV-1000-SAC-CS-S/S	62637	94.9
	CM	HV-1000-SAC-CM-S/S	62638	96.2
	CL	HV-1000-SAC-CL-S/S	62639	96.9
1200	CS	HV-1200-SAC-CS-S/S	62640	103.3
	CM	HV-1200-SAC-CM-S/S	62641	104.7
	CL	HV-1200-SAC-CL-S/S	62642	105.6
1400	CS	HV-1400-SAC-CS-S/S	62643	115.9
	CM	HV-1400-SAC-CM-S/S	62644	117.5
	CL	HV-1400-SAC-CL-S/S	62645	118.6
1600	CM	HV-1600-SAC-CM-S/S	62646	130.0
	CL	HV-1600-SAC-CL-S/S	62647	131.3
	CLL	HV-1600-SAC-CLL-S/S	62648	135.2
1800	CM	HV-1800-SAC-CM-S/S	62649	137.2
	CL	HV-1800-SAC-CL-S/S	62650	138.5
	CLL	HV-1800-SAC-CLL-S/S	62651	142.8
Dual Cartridge				
1200	CS	HV-1200-2SAC-CS-S/S	62673	128.7
	CM	HV-1200-2SAC-CM-S/S	62674	130.3
	CL	HV-1200-2SAC-CL-S/S	62675	131.2
	CLL	HV-1200-2SAC-CLL-S/S	62676	134.1
1400	CS	HV-1400-2SAC-CS-S/S	62677	137.4
	CM	HV-1400-2SAC-CM-S/S	62678	139.0
	CL	HV-1400-2SAC-CL-S/S	62679	140.1
	CLL	HV-1400-2SAC-CLL-S/S	62680	143.4
1600	CM	HV-1600-2SAC-CM-S/S	62681	147.9
	CL	HV-1600-2SAC-CL-S/S	62582	160.9
	CLL	HV-1600-2SAC-CLL-S/S	62683	152.9
1800	CM	HV-1800-2SAC-CM-S/S	62684	159.5
	CL	HV-1800-2SAC-CL-S/S	62685	160.9
	CLL	HV-1800-2SAC-CLL-S/S	62686	163.8
2000	CM	HV-2000-2SAC-CM-S/S	62687	169.2
	CL	HV-2000-2SAC-CL-S/S	62688	170.7
	CLL	HV-2000-2SAC-CLL-S/S	62689	174.0
2200	CM	HV-2200-2SAC-CM-S/S	62690	182.4
	CL	HV-2200-2SAC-CL-S/S	62691	184.1
	CLL	HV-2200-2SAC-CLL-S/S	62692	187.7
2400	CM	HV-2400-2SAC-CM-S/S	62693	187.5
	CL	HV-2400-2SAC-CL-S/S	62694	189.3
	CLL	HV-2400-2SAC-CLL-S/S	62695	193.3
2600	CM	HV-2600-2SAC-CM-S/S	62696	211.2
	CL	HV-2600-2SAC-CL-S/S	62697	213.2
	CLL	HV-2600-2SAC-CLL-S/S	62698	217.4
2800	CM	HV-2800-2SAC-CM-S/S	62699	220.9
	CL	HV-2800-2SAC-CL-S/S	62700	223.0
	CLL	HV-2800-2SAC-CLL-S/S	62701	227.7
3000	CM	HV-3000-2SAC-CM-S/S	62702	230.0
	CL	HV-3000-2SAC-CL-S/S	62703	232.3
	CLL	HV-3000-2SAC-CLL-S/S	62704	237.2

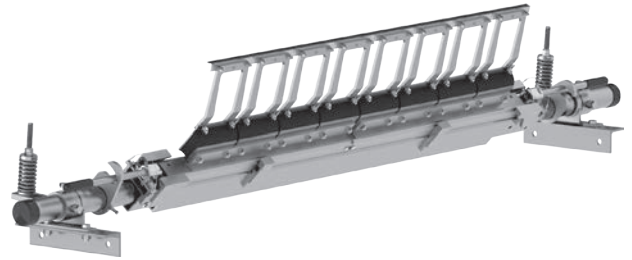

Stainless Steel H-Type ESAC Dual HD Primary Cleaner

Replacement V-Tips

ORDERING NUMBER	ITEM CODE	WT. KG.
HVT8-S/S	75419	0.9
HVPT-S/S	73631	1.2

Replacement Suspension Arms SS

SIZE	ORDERING NUMBER	ITEM CODE	WT. KG.
CS	HSA8CS-S/S	62509	1.1
CM	HSA8CM-S/S	62510	1.3
CL	HSA8CL-S/S	62511	1.5
CLL	HSA8CLL-S/S	62512	1.7

Suspension Arm Size

HEAD PULLEY DIAMETER + BELT & LAGGING mm	SUSPENSION ARM SIZE
500-799	CS
800-999	CM
1000-1199	CL
1200-1700	CLL

Over 1700mm - contact Flexco

Tips required per cleaner size

BELT WIDTH mm	BELT COVERAGE mm	V-TIPS REQUIRED
600	600	3
800	800	4
1000	1000	5
1200	1200	6
1400	1400	7
1600	1600	8
1800	1800	9
2000	2000	10
2200	2200	11
2400	2400	12
2600	2600	13
2800	2800	14
3000	3000	15

Stock items (non-shaded) refer to (*) for specific lead time, if not specified, standard lead time applies.

Non-stock items (shaded) please contact Flexco for dispatch options and lead times.

Product Ordering Information

H-Type ESAC (Stainless Steel) HD Primary Cleaner with Enhanced Service Advantage Cartridge™

H-Type ESAC Stainless Steel Replacement Cartridge Kits with V-Tips

TIP WIDTH	ARM SIZE	ORDERING NUMBER	ITEM CODE	Wght. KG.
Single Cartridge Kits				
600	CS	H CARK-600-CS-S/S	62652	23.2
	CM	H CARK-600-CM-S/S	62653	24.0
	CL	H CARK-600-CL-S/S	62654	24.5
800	CS	H CARK-800-CS-S/S	62655	30.3
	CM	H CARK-800-CM-S/S	62656	31.3
	CL	H CARK-800-CL-S/S	62657	31.9
1000	CS	H CARK-1000-CS-S/S	62658	36.1
	CM	H CARK-1000-CM-S/S	62659	37.4
	CL	H CARK-1000-CL-S/S	62660	38.2
1200	CS	H CARK-1200-CS-S/S	62661	41.4
	CM	H CARK-1200-CM-S/S	62662	43.3
	CL	H CARK-1200-CL-S/S	62663	44.2
1400	CS	H CARK-1400-CS-S/S	62664	49.0
	CM	H CARK-1400-CM-S/S	62665	50.8
	CL	H CARK-1400-CL-S/S	62666	51.9
1600	CM	H CARK-1600-CS-S/S	62667	58.1
	CL	H CARK-1600-CM-S/S	62668	59.3
	CLL	H CARK-1600-CL-S/S	62669	63.1
1800	CM	H CARK-1800-CS-S/S	62670	66.2
	CL	H CARK-1800-CM-S/S	62671	67.6
	CLL	H CARK-1800-CL-S/S	62672	71.9
Dual Cartridge Kits				
1200	CS	H-CARK2-1200-CS-S/S	62705	46.2
	CM	H-CARK2-1200-CM-S/S	62706	47.8
	CL	H-CARK2-1200-CL-S/S	62707	48.7
	CLL	H-CARK2-1200-CLL-S/S	62708	51.6
1400	CS	H-CARK2-1400-CS-S/S	62709	51.8
	CM	H-CARK2-1400-CM-S/S	62710	53.6
	CL	H-CARK2-1400-CL-S/S	62711	54.6
	CLL	H-CARK2-1400-CLL-S/S	62712	58.0
1600	CM	H-CARK2-1600-CM-S/S	62713	59.4
	CL	H-CARK2-1600-CL-S/S	62714	60.6
	CLL	H-CARK2-1600-CLL-S/S	62715	64.4
1800	CM	H-CARK2-1800-CM-S/S	62716	68.1
	CL	H-CARK2-1800-CL-S/S	62717	69.4
	CLL	H-CARK2-1800-CLL-S/S	62718	73.8
2000	CM	H-CARK2-2000-CM-S/S	62719	74.8
	CL	H-CARK2-2000-CL-S/S	62720	76.3
	CLL	H-CARK2-2000-CLL-S/S	62721	81.1
2200	CM	H-CARK2-2200-CM-S/S	62722	82.1
	CL	H-CARK2-2200-CL-S/S	62723	83.7
	CLL	H-CARK2-2200-CLL-S/S	62724	89.0
2400	CM	H-CARK2-2400-CM-S/S	62725	87.1
	CL	H-CARK2-2400-CL-S/S	62726	88.9
	CLL	H-CARK2-2400-CLL-S/S	62727	94.7
2600	CM	H-CARK2-2600-CM-S/S	62728	95.7
	CL	H-CARK2-2600-CL-S/S	62729	97.7
	CLL	H-CARK2-2600-CLL-S/S	62730	103.9
2800	CM	H-CARK2-2800-CM-S/S	62731	102.2
	CL	H-CARK2-2800-CL-S/S	62732	104.3
	CLL	H-CARK2-2800-CLL-S/S	62733	111.0
3000	CM	H-CARK2-3000-CM-S/S	62734	107.7
	CL	H-CARK2-3000-CL-S/S	62735	110.0
	CLL	H-CARK2-3000-CLL-S/S	62736	117.2

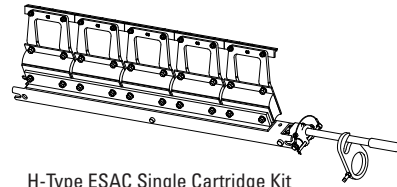

H-Type ESAC Single Cartridge Kit

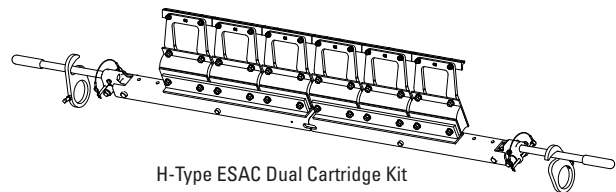

H-Type ESAC Dual Cartridge Kit

Stock items (non-shaded) refer to (*) for specific lead time, if not specified, standard lead time applies.

Non-stock items (shaded) please contact Flexco for dispatch options and lead times.

Replacement Parts List

H-Type ESAC Single HD Primary Cleaner with Enhanced Service Advantage Cartridge™

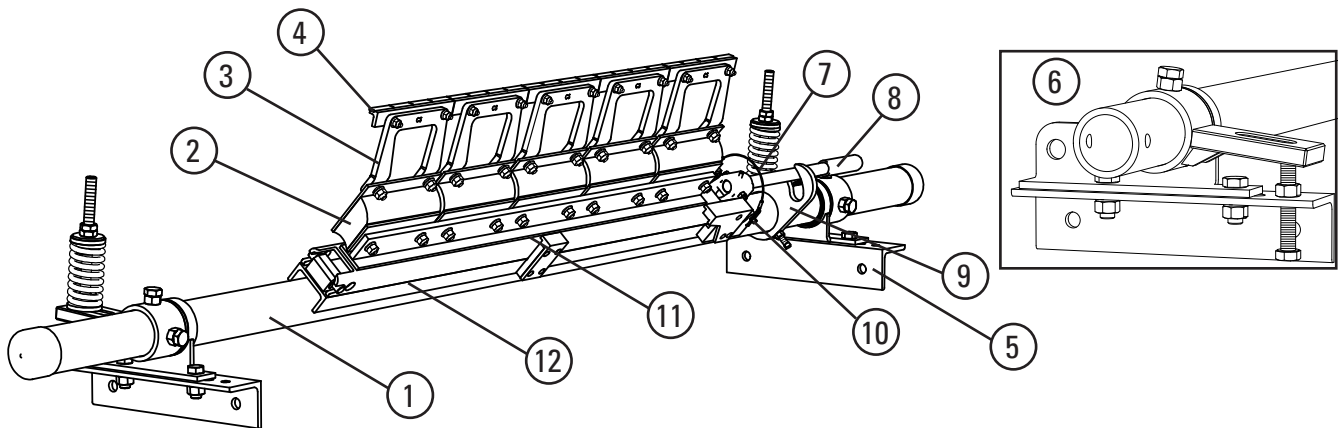

REPLACEMENT PARTS

REF	DESCRIPTION	MILD STEEL			STAINLESS STEEL		
		ORDERING NUMBER	ITEM CODE	WT. KG.	ORDERING NUMBER	ITEM CODE	WT. KG.
1	H-Type Single ESAC Cartridge Pole	HCP-600	62751	30.5	HCP-600-S/S	62757	31.4
		HCP-800	62752	35.6	HCP-800-S/S	62758	36.7
		HCP-1000	62753	38.1	HCP-1000-S/S	62759	39.3
		HCP-1200	62754	40.7	HCP-1200-S/S	62760	42
		HCP-1400	62755	45.9	HCP-1400-S/S	62761	47.3
		HCP-1800	62756	51.0	HCP-1800-S/S	62762	52.6
2	HD Cushion	HSHD	73483	2.0	HSHD-S/S	76467	2
3	Suspension Arm	HSA8CS	62505	0.9	HSA8CS-S/S	62509	1
		HSA8CM	62506	1.1	HSA8CM-S/S	62510	1.2
		HSA8CL	62507	1.3	HSA8CL-S/S	62511	1.3
		HSA8CLL	62508	1.8	HSA8CLL-S/S	62512	1.8
4	HV Tips	HSA200	73489	0.5	HVT8-S/S	75419	0.6
	HVPT Tips	-	-	-	HVPT-S/S	73631	0.6
5	Black Compression Spring Side Assembly (to 1600 belt width max)	H73CSK-B	62749	17.8	H73CSK-B-S/S	62750	18.3
	Gold Compression Spring Side Assembly (to 2400 belt width max)	H73CSK-G	62743	17.8	H73CSK-G-S/S	62744	18.3
6	Bolt Tension Side Assembly	H73BTK	63079	15.1	H73BTK-S/S	63080	15.6
7	SAC Removal Knuckle	SACRKN	77882	1.5			
8	SAC Removal Handle	SACRH	77883	1.4			
9	SAC Handle Lock Plate	SACRHL	77884	0.8			
10	Knuckle Retainer Pin	SACKRP	77885	0.1			
REF	DESCRIPTION	TIP WIDTH	ORDERING NUMBER	ITEM CODE	WT. KG.		
11	H-Type Cartridge Adapter Plate	600	H-SAC-AP-600	62452	3.5		
		800	H-SAC-AP-800	62453	4.8		
		1000	H-SAC-AP-1000	62454	6.0		
		1200	H-SAC-AP-1200	62455	7.3		
		1400	H-SAC-AP-1400	62456	8.5		
		1600	H-SAC-AP-1600	62457	9.8		
12	SAC Replacement Single Cartridge	600	CART-24/600-S/S	78576	4.5		
		800	CART-36/900-S/S	78578	6.7		
		1000	CART-42/1050-S/S	78579	7.8		
		1200	CART2-48/1200-S/S	78580	8.9		
		1400	CART-60/1500-S/S	78582	11.3		
		1600	CART-72/1800-S/S	78583	13.5		
		1800					

HV/HVP Single SAC Black Spring Length Chart (for optimal blade tensioning)

Belt Width	CS	CM	CL	CLL
600	111	110	109	107
800	109	107	107	104
1000	106	105	104	100
1200	104	102	101	97
1400	102	100	98	93
1600	100	97	96	90
1800	97	95	93	-

HV/HVP Single SAC Gold Spring Length Chart (for optimal blade tensioning)

Belt Width	CS	CM	CL	CLL
600	113	113	112	111
800	112	111	111	109
1000	111	110	109	107
1200	109	108	107	105
1400	108	106	106	102
1600	106	105	104	100
1800	105	103	102	98

HV/HVP Dual SAC Gold Spring Length Chart (for optimal blade tensioning)

Belt Width	CS	CM	CL	CLL
1200	109	108	108	105
1400	108	107	106	103
1600	107	105	104	101
1800	105	104	103	99
2000	104	102	101	96
2200	103	101	99	94

HV/HVP Dual SAC Silver Spring Length Chart (for optimal blade tensioning)

Belt Width	CS	CM	CL	CLL
2200	159	158	157	154
2400	158	157	156	153
2600	157	156	155	151
2800	157	155	154	150
3000	156	154	153	149

Stock items (non-shaded) refer to (*) for specific lead time, if not specified, standard lead time applies.

Non-stock items (shaded) please contact Flexco for dispatch options and lead times.

Replacement Parts List

H-Type ESAC Dual HD Primary Cleaner with Enhanced Service Advantage Cartridge™

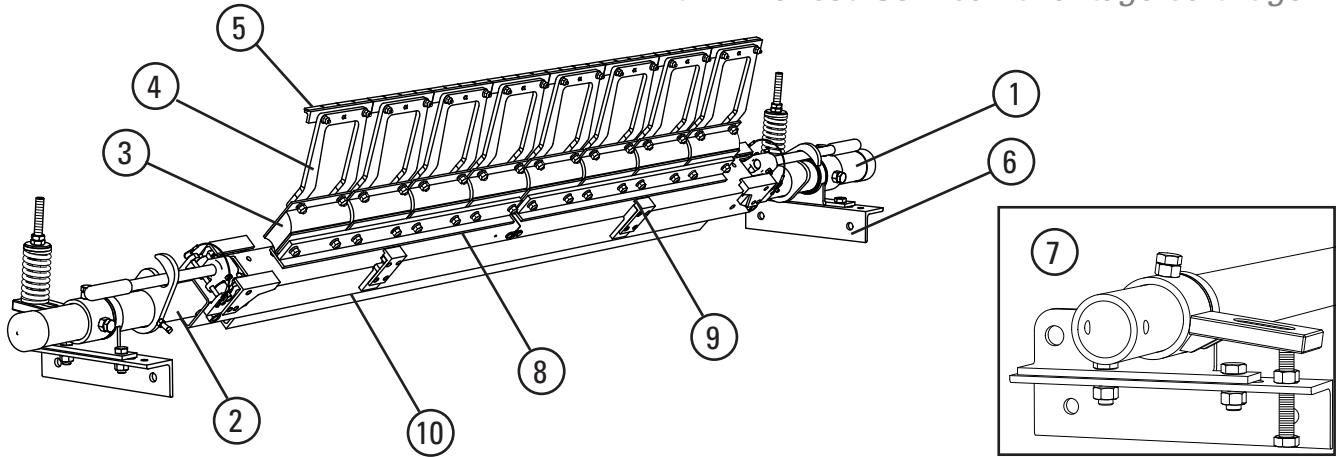

REPLACEMENT PARTS

REF	DESCRIPTION	MILD STEEL			STAINLESS STEEL			
		ORDERING NUMBER	ITEM CODE	WT. KG.	ORDERING NUMBER	ITEM CODE	WT. KG.	
1	H-Type Dual ESAC Centre Pole	H2CP-1200	62763	39.7	H2CP-1200-S/S	62801	39.7	
		H2CP-1400	62764	42.6	H2CP-1400-S/S	62802	42.6	
		H2CP-1600	62765	45.7	H2CP-1600-S/S	62803	45.7	
		H2CP-1800	62766	48.6	H2CP-1800-S/S	62804	48.6	
		H2CP-2000	62767	51.6	H2CP-2000-S/S	62805	51.6	
		H2CP-2400	62768	57.6	H2CP-2400-S/S	62806	57.6	
		H2CP-2600	62769	71.0	H2CP-2600-S/S	62807	71.0	
		H2CP-2800	62770	74.3	H2CP-2800-S/S	62808	74.3	
	H2CP-3000	62771	77.8	H2CP-3000-S/S	62809	77.8		
2	Extender Pole	MHP-EP	76392	24.5	MHP-EP-S/S	77599	24.5	
3	HD Cushion	HSHD	73483	2.0	HSHD-S/S	76467	2.0	
4	Suspension Arm	HSA8CS	62505	0.9	HSA8CS-S/S	62509	1.0	
		HSA8CM	62506	1.1	HSA8CM-S/S	62510	1.2	
		HSA8CL	62507	1.3	HSA8CL-S/S	62511	1.3	
		HSA8CLL	62508	1.8	HSA8CLL-S/S	62512	1.8	
5	HV Tips	HSA200	73489	0.5	HVT8-S/S	75419	0.6	
	HVPT Tips	-	-	-	HVPT-S/S	73631	0.6	
6	Black Compression Spring Side Assembly (to 1600 belt width max)	H73CSK-B	62749	17.8	H73CSK-B-S/S	62750	18.3	
	Gold Compression Spring Side Assembly (to 2400 belt width max)	H73CSK-G	62743	17.8	H73CSK-G-S/S	62744	18.3	
	Silver 6" Compression Spring Side Assembly (above 2400)	H73CSK-S	62745	18.0	H73CSK-S-S/S	62746	18.4	
7	Bolt Tension Side Assembly	H73BTK	63079	15.1	H73BTK-S/S	63080	15.6	
REF	DESCRIPTION	TIP WIDTH	ITEM 8 / LEFT HAND			ITEM 9 / RIGHT HAND		
			ORDERING NUMBER	ITEM CODE	WT. KG.	ORDERING NUMBER	ITEM CODE	WT. KG.
8 & 9	H-Type Cartridge Adapter Plate	1200	H-SAC-AP-600	62452	3.5	H-SAC-AP-600	62452	3.5
		1400	H-SAC-AP-800	62453	4.8	H-SAC-AP-600	62452	3.5
		1600	H-SAC-AP-800	62453	4.8	H-SAC-AP-800	62453	4.8
		1800	H-SAC-AP-1000	62454	6.0	H-SAC-AP-800	62453	4.8
		2000	H-SAC-AP-1000	62454	6.0	H-SAC-AP-1000	62454	6.0
		2200	H-SAC-AP-1200	62455	7.3	H-SAC-AP-1000	62454	6.0
		2400	H-SAC-AP-1200	62455	7.3	H-SAC-AP-1200	62455	7.3
		2600	H-SAC-AP-1400	62456	8.5	H-SAC-AP-1200	62455	7.3
		2800	H-SAC-AP-1400	62456	8.5	H-SAC-AP-1400	62456	8.5
		3000	H-SAC-AP-1600	62457	9.8	H-SAC-AP-1400	62456	8.5
REF	DESCRIPTION	TIP WIDTH	ORDERING NUMBER	ITEM CODE	WT. KG.			
10	SAC Replacement Dual Cartridge	1200	CART2-60/1500-S/S	78584	11.2			
		1400	CART2-66/1650-S/S	78634	12.3			
		1600	CART2-72/1800-S/S	78585	13.4			
		1800	CART2-78/1950-S/S	78635	14.5			
		2000	CART2-84/2100-S/S	78586	15.6			
		2200	CART2-96/2400-S/S	78587	17.8			
		2400						
		2600	CART2-114/2850-S/S	78639	23.7			
		2800	CART2-120/3000-S/S	78588	22.6			
		3000	CART2-126/3150-S/S	78640	23.7			

Product Ordering Information

H-Type ESAC with Extra Life V-Tips (Mild Steel) HD Primary Cleaner with Enhanced Service Advantage Cartridge™

Powder Coated H-Type® ESAC with Extra Life V-Tips

TIP WIDTH	ARM SIZE	ORDERING NUMBER	ITEM CODE	Wght. KG.
Single Cartridge				
600	CS	HV-600-SAC-CS-EL15	63206	74.2
	CM	HV-600-SAC-CM-EL15	63207	74.9
	CL	HV-600-SAC-CL-EL15	63208	75.3
800	CS	HV-800-SAC-CS-EL15	63209	86.5
	CM	HV-800-SAC-CM-EL15	63210	87.5
	CL	HV-800-SAC-CL-EL15	63211	88.1
1000	CS	HV-1000-SAC-CS-EL15	63212	94.9
	CM	HV-1000-SAC-CM-EL15	63213	96.2
	CL	HV-1000-SAC-CL-EL15	63214	96.9
1200	CS	HV-1200-SAC-CS-EL15	63215	103.3
	CM	HV-1200-SAC-CM-EL15	63216	104.7
	CL	HV-1200-SAC-CL-EL15	63217	105.6
1400	CS	HV-1400-SAC-CS-EL15	63218	115.9
	CM	HV-1400-SAC-CM-EL15	63219	117.5
	CL	HV-1400-SAC-CL-EL15	63220	118.6
1600	CM	HV-1600-SAC-CM-EL15	63221	130.0
	CL	HV-1600-SAC-CL-EL15	63222	131.3
	CLL	HV-1600-SAC-CLL-EL15	63223	135.2
1800	CM	HV-1800-SAC-CM-EL15	63224	137.2
	CL	HV-1800-SAC-CL-EL15	63225	138.5
	CLL	HV-1800-SAC-CLL-EL15	63226	142.8
Dual Cartridge				
1200	CS	HV-1200-2SAC-CS-EL15	63421	128.7
	CM	HV-1200-2SAC-CM-EL15	63422	130.3
	CL	HV-1200-2SAC-CL-EL15	63423	131.2
	CLL	HV-1200-2SAC-CLL-EL15	63424	134.1
1400	CS	HV-1400-2SAC-CS-EL15	63425	137.4
	CM	HV-1400-2SAC-CM-EL15	63426	139.0
	CL	HV-1400-2SAC-CL-EL15	63427	140.1
	CLL	HV-1400-2SAC-CLL-EL15	63428	143.4
1600	CM	HV-1600-2SAC-CM-EL15	63429	147.9
	CL	HV-1600-2SAC-CL-EL15	63430	149.1
	CLL	HV-1600-2SAC-CLL-EL15	63431	152.9
1800	CM	HV-1800-2SAC-CM-EL15	63432	159.5
	CL	HV-1800-2SAC-CL-EL15	63433	160.9
	CLL	HV-1800-2SAC-CLL-EL15	63434	163.8
2000	CM	HV-2000-2SAC-CM-EL15	63435	169.2
	CL	HV-2000-2SAC-CL-EL15	63436	170.7
	CLL	HV-2000-2SAC-CLL-EL15	63437	174.0
2200	CM	HV-2200-2SAC-CM-EL15	63438	182.4
	CL	HV-2200-2SAC-CL-EL15	63439	184.1
	CLL	HV-2200-2SAC-CLL-EL15	63440	187.7
2400	CM	HV-2400-2SAC-CM-EL15	63441	187.5
	CL	HV-2400-2SAC-CL-EL15	63442	189.3
	CLL	HV-2400-2SAC-CLL-EL15	63443	193.3
2600	CM	HV-2600-2SAC-CM-EL15	63444	211.2
	CL	HV-2600-2SAC-CL-EL15	63445	213.2
	CLL	HV-2600-2SAC-CLL-EL15	63446	217.4
2800	CM	HV-2800-2SAC-CM-EL15	63447	220.9
	CL	HV-2800-2SAC-CL-EL15	63448	223.0
	CLL	HV-2800-2SAC-CLL-EL15	63449	227.7
3000	CM	HV-3000-2SAC-CM-EL15	63450	230.0
	CL	HV-3000-2SAC-CL-EL15	63451	232.3
	CLL	HV-3000-2SAC-CLL-EL15	63452	237.2

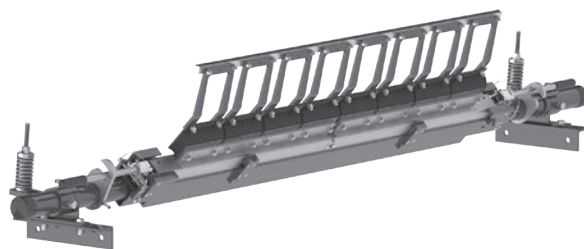

H-Type ESAC Dual HD Primary Cleaner

Replacement V-Tips

ORDERING NUMBER	ITEM CODE	WT. KG.
HSA200	73489	0.5
HSA200-EL15	76027	0.6

Replacement Suspension Arms

SIZE	ORDERING NUMBER	ITEM CODE	WT. KG.
CS	HSA8CS	62505	1.1
CM	HSA8CM	62506	1.3
CL	HSA8CL	62507	1.5
CLL	HSA8CLL	62508	1.7

Suspension Arm Size

HEAD PULLEY DIAMETER + BELT & LAGGING mm	SUSPENSION ARM SIZE
500-799	CS
800-999	CM
1000-1199	CL
1200-1700	CLL

Over 1700mm - contact Flexco

Tips required per cleaner size

BELT WIDTH mm	BELT COVERAGE mm	V-TIPS REQUIRED
600	600	3
800	800	4
1000	1000	5
1200	1200	6
1400	1400	7
1600	1600	8
1800	1800	9
2000	2000	10
2200	2200	11
2400	2400	12
2600	2600	13
2800	2800	14
3000	3000	15

Stock items (non-shaded) refer to (*) for specific lead time, if not specified, standard lead time applies.

Non-stock items (shaded) please contact Flexco for dispatch options and lead times.

Product Ordering Information

H-Type ESAC with Extra Life V-Tips (Mild Steel) HD Primary Cleaner with Enhanced Service Advantage Cartridge™

H-Type ESAC Mild Steel Replacement Cartridge Kits with Extra Life V-Tips

TIP WIDTH	ARM SIZE	ORDERING NUMBER	ITEM CODE	Wght. KG.
Single Cartridge Kits				
600	CS	H-CARK-600-CS-EL15	63631	23.2
	CM	H-CARK-600-CM-EL15	63632	24
	CL	H-CARK-600-CL-EL15	63633	24.5
800	CS	H-CARK-800-CS-EL15	63634	30.3
	CM	H-CARK-800-CM-EL15	63635	31.3
	CL	H-CARK-800-CL-EL15	63636	31.9
1000	CS	H-CARK-1000-CS-EL15	63637	36.1
	CM	H-CARK-1000-CM-EL15	63638	37.4
	CL	H-CARK-1000-CL-EL15	63639	38.2
1200	CS	H-CARK-1200-CS-EL15	63640	41.4
	CM	H-CARK-1200-CM-EL15	63641	43.3
	CL	H-CARK-1200-CL-EL15	63642	44.2
1400	CS	H-CARK-1400-CS-EL15	63643	49
	CM	H-CARK-1400-CM-EL15	63644	50.8
	CL	H-CARK-1400-CL-EL15	63645	51.9
1600	CM	H-CARK-1600-CS-EL15	63646	58.1
	CL	H-CARK-1600-CM-EL15	63647	59.3
	CLL	H-CARK-1600-CL-EL15	63648	63.1
1800	CM	H-CARK-1800-CS-EL15	63649	66.2
	CL	H-CARK-1800-CM-EL15	63650	67.6
	CLL	H-CARK-1800-CL-EL15	63651	71.9
Dual Cartridge Kits				
1200	CS	H-CARK2-1200-CS-EL15	63567	46.2
	CM	H-CARK2-1200-CM-EL15	63568	47.8
	CL	H-CARK2-1200-CL-EL15	63569	48.7
	CLL	H-CARK2-1200-CLL-EL15	63570	51.6
1400	CS	H-CARK2-1400-CS-EL15	63571	51.8
	CM	H-CARK2-1400-CM-EL15	63572	53.6
	CL	H-CARK2-1400-CL-EL15	63573	54.6
	CLL	H-CARK2-1400-CLL-EL15	63574	58
1600	CM	H-CARK2-1600-CM-EL15	63575	59.4
	CL	H-CARK2-1600-CL-EL15	63576	60.6
	CLL	H-CARK2-1600-CLL-EL15	63577	64.4
	CM	H-CARK2-1800-CM-EL15	63578	68.1
1800	CL	H-CARK2-1800-CL-EL15	63579	69.4
	CLL	H-CARK2-1800-CLL-EL15	63580	73.8
	CM	H-CARK2-2000-CM-EL15	63581	74.8
	CL	H-CARK2-2000-CL-EL15	63582	76.3
2000	CLL	H-CARK2-2000-CLL-EL15	63583	81.1
	CM	H-CARK2-2200-CM-EL15	63584	82.1
	CL	H-CARK2-2200-CL-EL15	63585	83.7
	CLL	H-CARK2-2200-CLL-EL15	63586	89
2400	CM	H-CARK2-2400-CM-EL15	63587	87.1
	CL	H-CARK2-2400-CL-EL15	63588	88.9
	CLL	H-CARK2-2400-CLL-EL15	63589	94.7
	CM	H-CARK2-2600-CM-EL15	63590	95.7
2600	CL	H-CARK2-2600-CL-EL15	63591	97.7
	CLL	H-CARK2-2600-CLL-EL15	63592	103.9
	CM	H-CARK2-2800-CM-EL15	63593	102.2
	CL	H-CARK2-2800-CL-EL15	63594	104.3
2800	CLL	H-CARK2-2800-CLL-EL15	63595	111
	CM	H-CARK2-3000-CM-EL15	63596	107.7
	CL	H-CARK2-3000-CL-EL15	63597	110
	CLL	H-CARK2-3000-CLL-EL15	63598	117.2

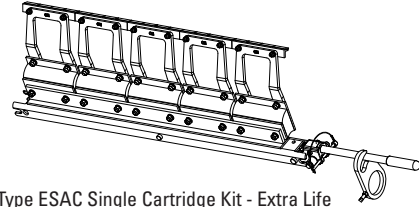

H-Type ESAC Single Cartridge Kit - Extra Life

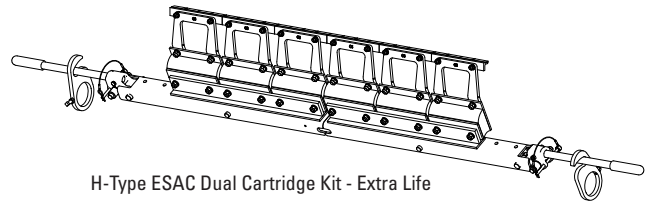

H-Type ESAC Dual Cartridge Kit - Extra Life

Stock items (non-shaded) refer to (*) for specific lead time, if not specified, standard lead time applies.

Non-stock items (shaded) please contact Flexco for dispatch options and lead times.

Product Ordering Information

H-Type ESAC with Extra Life V-Tips (Stainless Steel) HD Primary Cleaner with Enhanced Service Advantage Cartridge™

Stainless Steel H-Type® ESAC with Extra Life V-Tips

TIP WIDTH	ARM SIZE	ORDERING NUMBER	ITEM CODE	Wght. KG.
Single Cartridge				
600	CS	HV-600-SAC-CS-S/S-EL15	63227	74.2
	CM	HV-600-SAC-CM-S/S-EL15	63228	74.9
	CL	HV-600-SAC-CL-S/S-EL15	63229	75.3
800	CS	HV-800-SAC-CS-S/S-EL15	63230	86.5
	CM	HV-800-SAC-CM-S/S-EL15	63231	87.5
	CL	HV-800-SAC-CL-S/S-EL15	63232	88.1
1000	CS	HV-1000-SAC-CS-S/S-EL15	63233	94.9
	CM	HV-1000-SAC-CM-S/S-EL15	63234	96.2
	CL	HV-1000-SAC-CL-S/S-EL15	63235	96.9
1200	CS	HV-1200-SAC-CS-S/S-EL15	63236	103.3
	CM	HV-1200-SAC-CM-S/S-EL15	63237	104.7
	CL	HV-1200-SAC-CL-S/S-EL15	63238	105.6
1400	CS	HV-1400-SAC-CS-S/S-EL15	63239	115.9
	CM	HV-1400-SAC-CM-S/S-EL15	63240	117.5
	CL	HV-1400-SAC-CL-S/S-EL15	63241	118.6
1600	CM	HV-1600-SAC-CM-S/S-EL15	63242	130.0
	CL	HV-1600-SAC-CL-S/S-EL15	63243	131.3
	CLL	HV-1600-SAC-CLL-S/S-EL15	63244	135.2
1800	CM	HV-1800-SAC-CM-S/S-EL15	63245	137.2
	CL	HV-1800-SAC-CL-S/S-EL15	63246	138.5
	CLL	HV-1800-SAC-CLL-S/S-EL15	63247	142.8
Dual Cartridge				
1200	CS	HV-1200-2SAC-CS-S/S-EL15	63453	128.7
	CM	HV-1200-2SAC-CM-S/S-EL15	63454	130.3
	CL	HV-1200-2SAC-CL-S/S-EL15	63455	131.2
	CLL	HV-1200-2SAC-CLL-S/S-EL15	63456	134.1
1400	CS	HV-1400-2SAC-CS-S/S-EL15	63457	137.4
	CM	HV-1400-2SAC-CM-S/S-EL15	63458	139.0
	CL	HV-1400-2SAC-CL-S/S-EL15	63459	140.1
	CLL	HV-1400-2SAC-CLL-S/S-EL15	63460	143.4
1600	CM	HV-1600-2SAC-CM-S/S-EL15	63461	147.9
	CL	HV-1600-2SAC-CL-S/S-EL15	63462	149.1
	CLL	HV-1600-2SAC-CLL-S/S-EL15	63463	152.9
1800	CM	HV-1800-2SAC-CM-S/S-EL15	63464	159.5
	CL	HV-1800-2SAC-CL-S/S-EL15	63465	160.9
	CLL	HV-1800-2SAC-CLL-S/S-EL15	63466	163.8
2000	CM	HV-2000-2SAC-CM-S/S-EL15	63467	169.2
	CL	HV-2000-2SAC-CL-S/S-EL15	63468	170.7
	CLL	HV-2000-2SAC-CLL-S/S-EL15	63469	174.0
2200	CM	HV-2200-2SAC-CM-S/S-EL15	63470	182.4
	CL	HV-2200-2SAC-CL-S/S-EL15	63471	184.1
	CLL	HV-2200-2SAC-CLL-S/S-EL15	63472	187.7
2400	CM	HV-2400-2SAC-CM-S/S-EL15	63473	187.5
	CL	HV-2400-2SAC-CL-S/S-EL15	63474	189.3
	CLL	HV-2400-2SAC-CLL-S/S-EL15	63475	193.3
2600	CM	HV-2600-2SAC-CM-S/S-EL15	63476	211.2
	CL	HV-2600-2SAC-CL-S/S-EL15	63477	213.2
	CLL	HV-2600-2SAC-CLL-S/S-EL15	63478	217.4
2800	CM	HV-2800-2SAC-CM-S/S-EL15	63479	220.9
	CL	HV-2800-2SAC-CL-S/S-EL15	63480	223.0
	CLL	HV-2800-2SAC-CLL-S/S-EL15	63481	227.7
3000	CM	HV-3000-2SAC-CM-S/S-EL15	63482	230.0
	CL	HV-3000-2SAC-CL-S/S-EL15	63483	232.3
	CLL	HV-3000-2SAC-CLL-S/S-EL15	63484	237.2

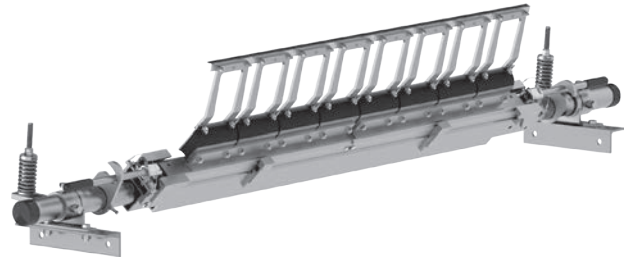

Stainless Steel H-Type ESAC Dual HD Primary Cleaner

Replacement V-Tips

ORDERING NUMBER	ITEM CODE	WT. KG.
HVT8-S/S	75419	0.9
HVPT-S/S	73631	1.2

Replacement Suspension Arms SS

SIZE	ORDERING NUMBER	ITEM CODE	WT. KG.
CS	HSA8CS-S/S	62509	1.1
CM	HSA8CM-S/S	62510	1.3
CL	HSA8CL-S/S	62511	1.5
CLL	HSA8CLL-S/S	62512	1.7

Suspension Arm Size

HEAD PULLEY DIAMETER + BELT & LAGGING mm	SUSPENSION ARM SIZE
500-799	CS
800-999	CM
1000-1199	CL
1200-1700	CLL

Over 1700mm - contact Flexco

Tips required per cleaner size

BELT WIDTH mm	BELT COVERAGE mm	V-TIPS REQUIRED
600	600	3
800	800	4
1000	1000	5
1200	1200	6
1400	1400	7
1600	1600	8
1800	1800	9
2000	2000	10
2200	2200	11
2400	2400	12
2600	2600	13
2800	2800	14
3000	3000	15

Stock items (non-shaded) refer to (*) for specific lead time, if not specified, standard lead time applies.

Non-stock items (shaded) please contact Flexco for dispatch options and lead times.

Product Ordering Information

H-Type ESAC with Extra Life V-Tips (Stainless Steel) HD Primary Cleaner with Enhanced Service Advantage Cartridge™

H-Type ESAC Stainless Steel Replacement Cartridge Kits with Extra Life V-Tips

TIP WIDTH	ARM SIZE	ORDERING NUMBER	ITEM CODE	Wght. KG.
Single Cartridge Kits				
600	CS	H CARK-600-CS-S/S-EL15	63652	23.2
	CM	H CARK-600-CM-S/S-EL15	63653	24
	CL	H CARK-600-CL-S/S-EL15	63654	24.5
800	CS	H CARK-800-CS-S/S-EL15	63655	30.3
	CM	H CARK-800-CM-S/S-EL15	63656	31.3
	CL	H CARK-800-CL-S/S-EL15	63657	31.9
1000	CS	H CARK-1000-CS-S/S-EL15	63658	36.1
	CM	H CARK-1000-CM-S/S-EL15	63659	37.4
	CL	H CARK-1000-CL-S/S-EL15	63660	38.2
1200	CS	H CARK-1200-CS-S/S-EL15	63661	41.4
	CM	H CARK-1200-CM-S/S-EL15	63662	43.3
	CL	H CARK-1200-CL-S/S-EL15	63663	44.2
1400	CS	H CARK-1400-CS-S/S-EL15	63664	49
	CM	H CARK-1400-CM-S/S-EL15	63665	50.8
	CL	H CARK-1400-CL-S/S-EL15	63666	51.9
1600	CM	H CARK-1600-CS-S/S-EL15	63667	58.1
	CL	H CARK-1600-CM-S/S-EL15	63668	59.3
	CLL	H CARK-1600-CL-S/S-EL15	63669	63.1
1800	CM	H CARK-1800-CS-S/S-EL15	63670	66.2
	CL	H CARK-1800-CM-S/S-EL15	63671	67.6
	CLL	H CARK-1800-CL-S/S-EL15	63672	71.9
Dual Cartridge Kits				
1200	CS	H-CARK2-1200-CS-S/S-EL15	63599	46.2
	CM	H-CARK2-1200-CM-S/S-EL15	63600	47.8
	CL	H-CARK2-1200-CL-S/S-EL15	63601	48.7
	CLL	H-CARK2-1200-CLL-S/S-EL15	63602	51.6
1400	CS	H-CARK2-1400-CS-S/S-EL15	63603	51.8
	CM	H-CARK2-1400-CM-S/S-EL15	63604	53.6
	CL	H-CARK2-1400-CL-S/S-EL15	63605	54.6
	CLL	H-CARK2-1400-CLL-S/S-EL15	63606	58
1600	CM	H-CARK2-1600-CM-S/S-EL15	63607	59.4
	CL	H-CARK2-1600-CL-S/S-EL15	63608	60.6
	CLL	H-CARK2-1600-CLL-S/S-EL15	63609	64.4
	CM	H-CARK2-1800-CM-S/S-EL15	63610	68.1
1800	CL	H-CARK2-1800-CL-S/S-EL15	63611	69.4
	CLL	H-CARK2-1800-CLL-S/S-EL15	63612	73.8
	CM	H-CARK2-2000-CM-S/S-EL15	63613	74.8
	CL	H-CARK2-2000-CL-S/S-EL15	63614	76.3
2000	CLL	H-CARK2-2000-CLL-S/S-EL15	63615	81.1
	CM	H-CARK2-2200-CM-S/S-EL15	63616	82.1
	CL	H-CARK2-2200-CL-S/S-EL15	63617	83.7
	CLL	H-CARK2-2200-CLL-S/S-EL15	63618	89
2400	CM	H-CARK2-2400-CM-S/S-EL15	63619	87.1
	CL	H-CARK2-2400-CL-S/S-EL15	63620	88.9
	CLL	H-CARK2-2400-CLL-S/S-EL15	63621	94.7
	CM	H-CARK2-2600-CM-S/S-EL15	63622	95.7
2600	CL	H-CARK2-2600-CL-S/S-EL15	63623	97.7
	CLL	H-CARK2-2600-CLL-S/S-EL15	63624	103.9
	CM	H-CARK2-2800-CM-S/S-EL15	63625	102.2
	CL	H-CARK2-2800-CL-S/S-EL15	63626	104.3
2800	CLL	H-CARK2-2800-CLL-S/S-EL15	63627	111
	CM	H-CARK2-3000-CM-S/S-EL15	63628	107.7
	CL	H-CARK2-3000-CL-S/S-EL15	63629	110
	CLL	H-CARK2-3000-CLL-S/S-EL15	63630	117.2

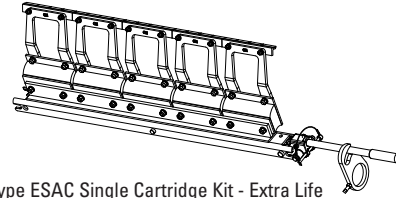

H-Type ESAC Single Cartridge Kit - Extra Life

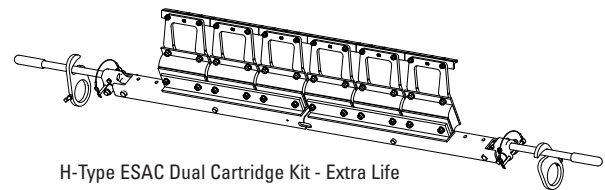

H-Type ESAC Dual Cartridge Kit - Extra Life

Stock items (non-shaded) refer to (*) for specific lead time, if not specified, standard lead time applies.

Non-stock items (shaded) please contact Flexco for dispatch options and lead times.

Replacement Parts List

H-Type ESAC with Extra Life V-Tips Single HD Primary Cleaner with Enhanced Service Advantage Cartridge™

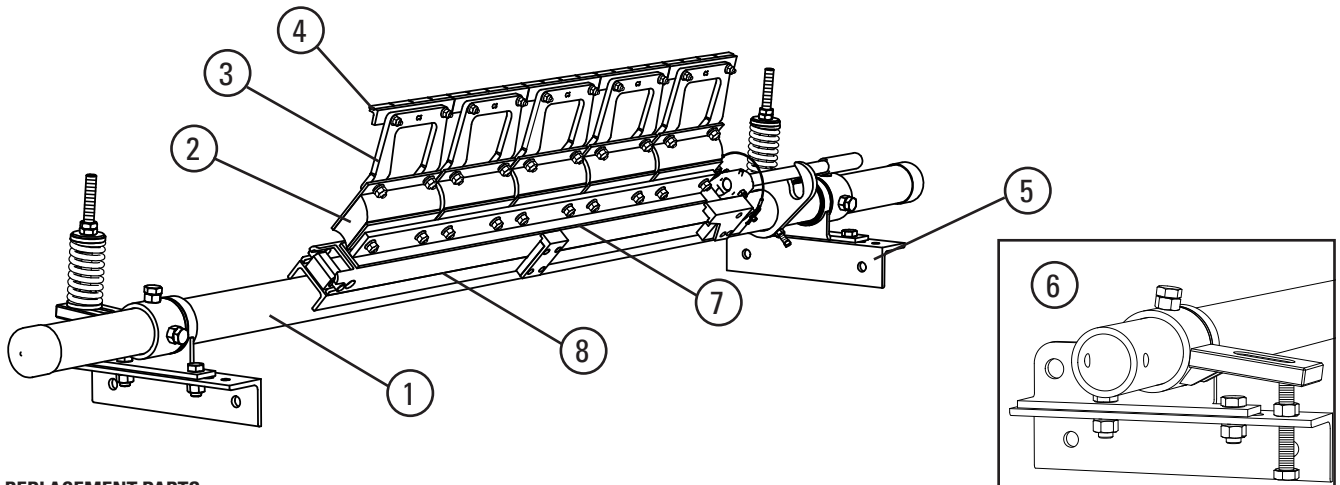

REPLACEMENT PARTS

REF	DESCRIPTION	MILD STEEL			STAINLESS STEEL		
		ORDERING NUMBER	ITEM CODE	WT. KG.	ORDERING NUMBER	ITEM CODE	WT. KG.
1	H-Type Single ESAC Cartridge Pole	HCP-600	62751	30.5	HCP-600-S/S	62757	31.4
		HCP-800	62752	35.6	HCP-800-S/S	62758	36.7
		HCP-1000	62753	38.1	HCP-1000-S/S	62759	39.3
		HCP-1200	62754	40.7	HCP-1200-S/S	62760	42
		HCP-1400	62755	45.9	HCP-1400-S/S	62761	47.3
		HCP-1800	62756	51.0	HCP-1800-S/S	62762	52.6
2	HD Cushion	HSHD	73483	2.0	HSHD-S/S	76467	2.0
3	Suspension Arm	HSA8CS	62505	0.9	HSA8CS-S/S	62509	1.0
		HSA8CM	62506	1.1	HSA8CM-S/S	62510	1.2
		HSA8CL	62507	1.3	HSA8CL-S/S	62511	1.3
		HSA8CLL	62508	1.8	HSA8CLL-S/S	62512	1.8
4	HV Tips	HSA200	73489	0.5	HVT8-S/S	75419	0.6
	HV EL15 Tips	HSA200-EL15	76027	0.5	HVT8-EL15-S/S	62254	0.6
	-	-	-	-	HVPT-S/S	73631	0.6
5	Black Compression Spring Side Assembly (to 1600 belt width max)	H73CSK-B	62749	17.8	H73CSK-B-S/S	62750	18.3
	Gold Compression Spring Side Assembly (to 2400 belt width max)	H73CSK-G	62743	17.8	H73CSK-G-S/S	62744	18.3
6	Bolt Tension Side Assembly	H73BTK	63079	15.1	H73BTK-S/S	63080	15.6
REF	DESCRIPTION	TIP WIDTH	ORDERING NUMBER	ITEM CODE	WT. KG.		
7	H-Type Cartridge Adapter Plate	600	H-SAC-AP-600	62452	3.5		
		800	H-SAC-AP-800	62453	4.8		
		1000	H-SAC-AP-1000	62454	6.0		
		1200	H-SAC-AP-1200	62455	7.3		
		1400	H-SAC-AP-1400	62456	8.5		
		1600	H-SAC-AP-1600	62457	9.8		
8	SAC Replacement Single Cartridge	1800	H-SAC-AP-1800	62458	11.0		
		600	CART-24/600-S/S	78576	4.5		
		800	CART-36/900-S/S	78578	6.7		
		1000	CART-42/1050-S/S	78579	7.8		
		1200	CART-48/1200-S/S	78580	8.9		
		1400	CART-60/1500-S/S	78582	11.3		
		1600	CART-72/1800-S/S	78583	13.5		
1800							

HV/HVP Single SAC Black Spring Length Chart (for optimal blade tensioning)

Belt Width	CS	CM	CL	CLL
600	111	110	109	107
800	109	107	107	104
1000	106	105	104	100
1200	104	102	101	97
1400	102	100	98	93
1600	100	97	96	90
1800	97	95	93	-

HV/HVP Single SAC Gold Spring Length Chart (for optimal blade tensioning)

Belt Width	CS	CM	CL	CLL
600	113	113	112	111
800	112	111	111	109
1000	111	110	109	107
1200	109	108	107	105
1400	108	106	106	102
1600	106	105	104	100
1800	105	103	102	98

HV/HVP Dual SAC Gold Spring Length Chart (for optimal blade tensioning)

Belt Width	CS	CM	CL	CLL
1200	109	108	108	105
1400	108	107	106	103
1600	107	105	104	101
1800	105	104	103	99
2000	104	102	101	96
2200	103	101	99	94

HV/HVP Dual SAC Silver Spring Length Chart (for optimal blade tensioning)

Belt Width	CS	CM	CL	CLL
2200	159	158	157	154
2400	158	157	156	153
2600	157	156	155	151
2800	157	155	154	150
3000	156	154	153	149

Stock items (non-shaded) refer to (*) for specific lead time, if not specified, standard lead time applies.

Non-stock items (shaded) please contact Flexco for dispatch options and lead times.

Replacement Parts List

H-Type ESAC with Extra Life V-Tips Dual HD Primary Cleaner with Enhanced Service Advantage Cartridge™

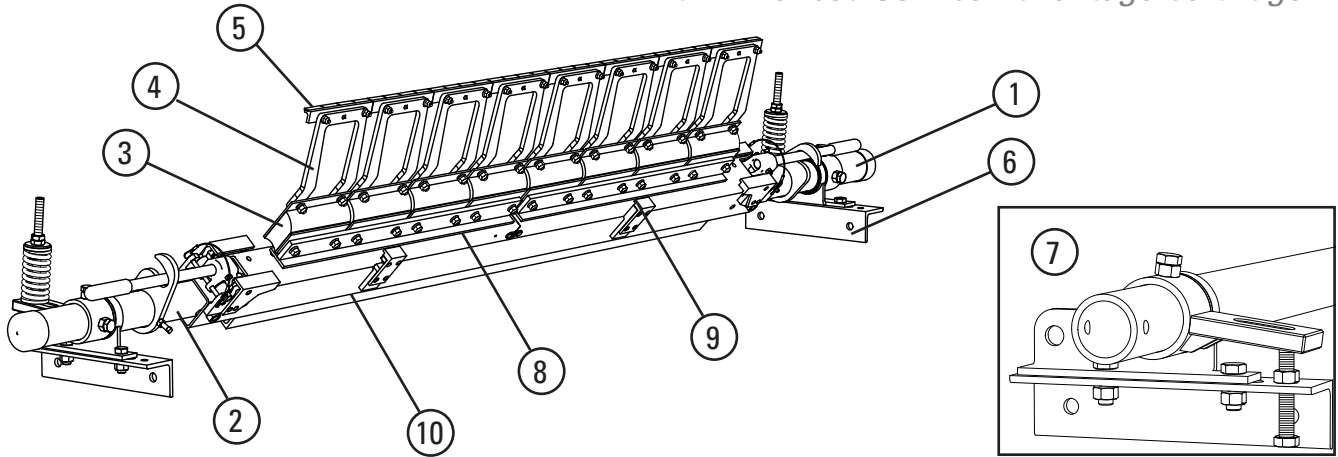

REPLACEMENT PARTS

REF	DESCRIPTION	MILD STEEL			STAINLESS STEEL		
		ORDERING NUMBER	ITEM CODE	WT. KG.	ORDERING NUMBER	ITEM CODE	WT. KG.
1	H-Type Dual ESAC Centre Pole	H2CP-1200	62763	39.7	H2CP-1200-S/S	62801	39.7
		H2CP-1400	62764	42.6	H2CP-1400-S/S	62802	42.6
		H2CP-1600	62765	45.7	H2CP-1600-S/S	62803	45.7
		H2CP-1800	62766	48.6	H2CP-1800-S/S	62804	48.6
		H2CP-2000	62767	51.6	H2CP-2000-S/S	62805	51.6
		H2CP-2400	62768	57.6	H2CP-2400-S/S	62806	57.6
		H2CP-2600	62769	71.0	H2CP-2600-S/S	62807	71.0
		H2CP-2800	62770	74.3	H2CP-2800-S/S	62808	74.3
		H2CP-3000	62771	77.8	H2CP-3000-S/S	62809	77.8
2	Extender Pole	MHP-EP	76392	24.5	MHP-EP-S/S	77599	24.5
3	HD Cushion	HSHD	73483	2.0	HSHD-S/S	76467	2.0
4	Suspension Arm	HSA8CS	62505	0.9	HSA8CS-S/S	62509	1.0
		HSA8CM	62506	1.1	HSA8CM-S/S	62510	1.2
		HSA8CL	62507	1.3	HSA8CL-S/S	62511	1.3
		HSA8CLL	62508	1.8	HSA8CLL-S/S	62512	1.8
5	HV Tips	HSA200	73489	0.5	HVT8-S/S	75419	0.6
	HV EL15 Tips	HSA200-EL15	76027	0.5	HVT8-EL15-S/S	63566	0.6
6	Black Compression Spring Side Assembly (to 1600 belt width max)	H73CSK-B	62749	17.8	H73CSK-B-S/S	62750	18.3
	Gold Compression Spring Side Assembly (to 2400 belt width max)	H73CSK-G	62743	17.8	H73CSK-G-S/S	62744	18.3
	Silver 6" Compression Spring Side Assembly (above 2400)	H73CSK-S	62745	18.0	H73CSK-S-S/S	62746	18.4
7	Bolt Tension Side Assembly	H73BTK	63079	15.1	H73BTK-S/S	63080	15.6

REF	DESCRIPTION	TIP WIDTH	ITEM 8 / LEFT HAND			ITEM 9 / RIGHT HAND		
			ORDERING NUMBER	ITEM CODE	WT. KG.	ORDERING NUMBER	ITEM CODE	WT. KG.
8 & 9	H-Type Cartridge Adapter Plate	1200	H-SAC-AP-600	62452	3.5	H-SAC-AP-600	62452	3.5
		1400	H-SAC-AP-800	62453	4.8	H-SAC-AP-600	62452	3.5
		1600	H-SAC-AP-800	62453	4.8	H-SAC-AP-800	62453	4.8
		1800	H-SAC-AP-1000	62454	6.0	H-SAC-AP-800	62453	4.8
		2000	H-SAC-AP-1000	62454	6.0	H-SAC-AP-1000	62454	6.0
		2200	H-SAC-AP-1200	62455	7.3	H-SAC-AP-1000	62454	6.0
		2400	H-SAC-AP-1200	62455	7.3	H-SAC-AP-1200	62455	7.3
		2600	H-SAC-AP-1400	62456	8.5	H-SAC-AP-1200	62455	7.3
		2800	H-SAC-AP-1400	62456	8.5	H-SAC-AP-1400	62456	8.5
3000	H-SAC-AP-1600	62457	9.8	H-SAC-AP-1400	62456	8.5		

REF	DESCRIPTION	TIP WIDTH	ORDERING NUMBER	ITEM CODE	WT. KG.
10	SAC Replacement Dual Cartridge	1200	CART2-60/1500-S/S	78584	11.2
		1400	CART2-66/1650-S/S	78634	12.3
		1600	CART2-72/1800-S/S	78585	13.4
		1800	CART2-78/1950-S/S	78635	14.5
		2000	CART2-84/2100-S/S	78586	15.6
		2200	CART2-96/2400-S/S	78587	17.8
		2400			
		2600	CART2-114/2850-S/S	78639	23.7
		2800	CART2-120/3000-S/S	78588	22.6
3000	CART2-126/3150-S/S	78640	23.7		

Stock items (non-shaded) refer to (*) for specific lead time, if not specified, standard lead time applies.
Non-stock items (shaded) please contact Flexco for dispatch options and lead times.

Replacement Parts List

H-Type with PCST Optional Tensioners

ATV Replacement Parts

REF	DESCRIPTION	ORDERING NUMBER	ITEM CODE	WT. KG.
1	Air Primary Mount Bracket Stainless Steel	AIR HDMRK S/S	62034	2.0
2	Bearing Repair Kit 60mm	HBRK-S/S-60	75422	1.5
	Bearing Repair Kit 73mm	HBRK-S/S-73	76246	2.0
3	Air Primary Adjust Arm 60mm	AIR HARK-S/S-60	62035	1.5
	Air Primary Adjust Arm 73mm	AIR HARK-S/S-73	64175	2.0
4	Air Bag Primary	AIR BAG P	62036	0.5
5	Hex Nut	HEX NUT	G1211	0.1
6	Air Line Adapter	ATV-NIP	62037	0.1
-	Primary Ait Tension Kit 60mm (incl. 2 ea items AIR HDMRK S/S, HBRK-S/S-60, AIR HARK-S/S-60, AIR BAG P, HEX NUT, ATV-NIP)	HATDMK-S/S	63861	11.0
-	Primary Ait Tension Kit 73mm (incl. 2 ea items AIR HDMRK S/S, HBRK-S/S-73, AIR HARK-S/S-73, AIR BAG P, HEX NUT, ATV-NIP)	HDATDMK-S/S	63862	14.0

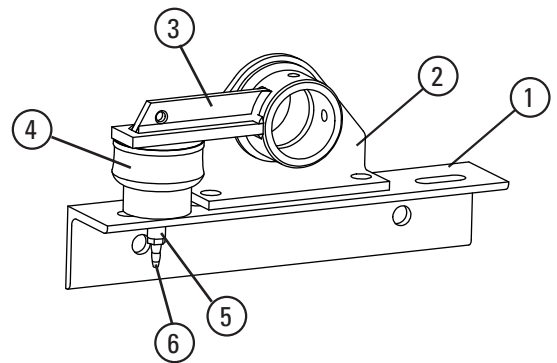

P-CST Replacement Parts - Mild Steel PCST 60mm

REF	DESCRIPTION	ORDERING NUMBER	ITEM CODE	WT. KG.
1	H Bearing Bush 60mm	HCSBB-60	62513	0.1
2	Acme Pivot Rod Kit	ACME-PRK	62496	0.6
3	Acme Nut	ACME-N	62591	0.1
4a	Spring Black (To 1600 Belt Width Max)	STS-B	75844	0.5
4b	Spring Gold (To 2400 Belt Width Max)	STS-G	78142	0.5
5	Spring Bush Kit (Black/Gold)	HCSSB-B/G	62589	0.1
6	Torque Arm Kit 60mm	ESTAK-EST	76406	1.6
-	Black 60mm Compression Spring Side Assembly (to 1600 belt width max)	H60CSK-B	62747	16.8
-	Gold 60mm Compression Spring Side Assembly (to 2400 belt width max)	H60CSK-G	62741	16.8

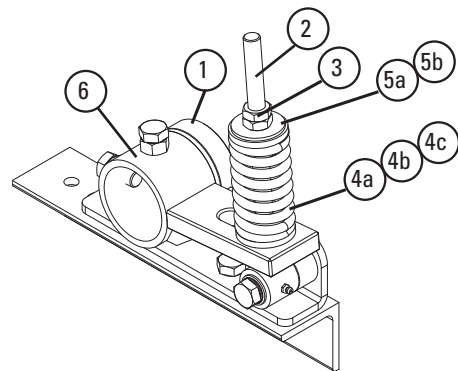

P-CST Replacement Parts - Mild Steel PCST 73mm

REF	DESCRIPTION	ORDERING NUMBER	ITEM CODE	WT. KG.
1	H Bearing Bush 73mm	HCSBB-73	62514	2.0
2	Acme Pivot Rod Kit	ACME-PRK	62496	0.6
3	Acme Nut	ACME-N	62591	0.1
4a	Spring Black (To 1600 Belt Width Max)	STS-B	75844	0.5
4b	Spring Gold (To 2400 Belt Width Max)	STS-G	78142	0.5
4c	Spring Silver (Above 2400 Belt Width)	PSTS-S	75899	0.5
5a	Spring Bush (Black/Gold)	HCSSB-B/G	62589	0.1
5b	Spring Bush (Silver)	HCSSB-S	62590	0.2
6	Torque Arm Kit 73mm	HCSTAK	62494	1.6
-	Black 73mm Compression Spring Side Assembly (to 1600 belt width max)	H73CSK-B	62749	17.8
-	Gold 73mm Compression Spring Side Assembly (to 2400 belt width max)	H73CSK-G	62743	17.8
-	Silver 73mm Compression Spring Side Assembly (above 2400)	H73CSK-S	62745	18

P-CST Replacement Parts - Stainless Steel PCST 73mm

REF	DESCRIPTION	ORDERING NUMBER	ITEM CODE	WT. KG.
1	H Bearing Bush 73mm	HCSBB-73	62514	2.0
2	Acme Pivot Rod Kit	ACME-PRK	62496	0.6
3	Acme Nut	ACME-N	62591	0.1
4a	Spring Black (To 1600 Belt Width Max)	STS-B-S/S	77632	0.5
4b	Spring Gold (To 2400 Belt Width Max)	STS-G-S/S	79057	0.5
4c	Spring Silver (Above 2400 Belt Width)	PSTS-S-S/S	79056	0.5
5a	Spring Bush (Black/Gold)	HCSSB-B/G	62589	0.1
5b	Spring Bush (Silver)	HCSSB-S	62590	0.2
6	Torque Arm Kit 73mm	HCSTAK-S/S	62495	1.6
-	Black 73mm Compression Spring Side Assembly (to 1600 belt width max)	H73CSK-B-S/S	62750	18.3
-	Gold 73mm Compression Spring Side Assembly (to 2400 belt width max)	H73CSK-G-S/S	62744	18.3
-	Silver 73mm Compression Spring Side Assembly (above 2400 belt width max)	H73CSK-S-S/S	62746	18.4

P-CST Replacement Parts - Stainless Steel PCST 60mm

REF	DESCRIPTION	ORDERING NUMBER	ITEM CODE	WT. KG.
1	H Bearing Bush 60mm	HCSBB-60	62513	0.1
2	Acme Pivot Rod Kit	ACME-PRK	62496	0.6
3	Acme Nut	ACME-N	62591	0.1
4a	Spring Black (To 1600 Belt Width Max)	STS-B-S/S	77632	0.5
4b	Spring Gold (To 2400 Belt Width Max)	STS-G-S/S	79057	0.5
5	Spring Bush Kit (Black/Gold)	HCSSB-B/G	62589	0.1
6	Torque Arm Kit 60mm	ESTAK-EST-S/S	78849	1.6
-	Black 60mm Compression Spring Side Assembly (to 1600 belt width max)	H60CSK-B-S/S	62748	17.3
-	Gold 60mm Compression Spring Side Assembly (to 2400 belt width max)	H60CSK-G-S/S	62742	17.3

Stock items (non-shaded) refer to (*) for specific lead time, if not specified, standard lead time applies.

Non-stock items (shaded) please contact Flexco for dispatch options and lead times.

Product Ordering Information

Y-Type™ Standard Duty Secondary Cleaner with Carbide or Polyurethane Blades

Y-Type™ Standard Duty with Purple Polyurethane Blades and YST Tension

BELT WIDTH	ORDERING NUMBER	ITEM CODE	WT. KGS.
450	YT-450S	83229	26.8
600	YT-600S	83230	29.5
750	YT-750S	83231	32.3
900	YT-900S	83232	35.0
1050	YT-1050S	83233	37.7
1200	YT-1200S	83234	40.5

Lead time: 2 weeks

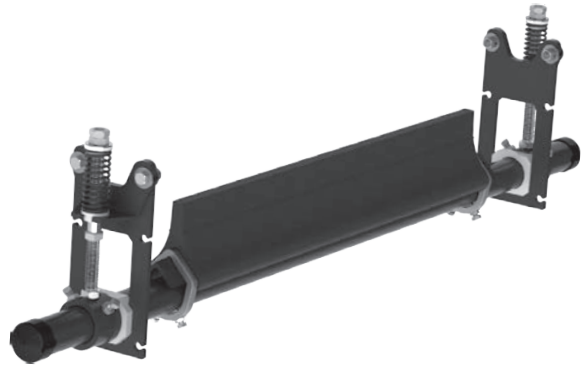

Y-Type™ Standard Duty with Carbide Blades and Bolt Tension

BELT WIDTH	ORDERING NUMBER	ITEM CODE	WT. KGS.
450	YTC-450	83223	30.6
600	YTC-600	83224	33.3
750	YTC-750	83225	36.1
900	YTC-900	83226	38.8
1050	YTC-1050	83227	41.5
1200	YTC-1200	83228	44.3

Lead time: 2 weeks

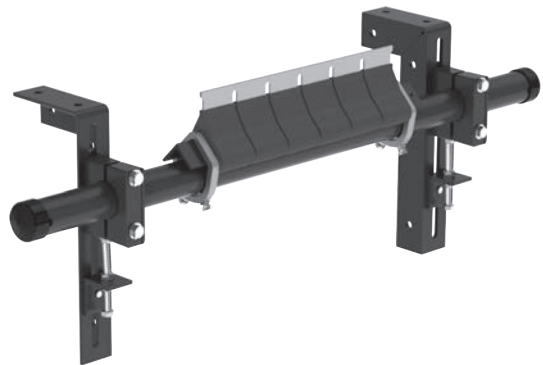

Y-Type™ Standard Duty with Carbide Blades and YST Tension

BELT WIDTH	ORDERING NUMBER	ITEM CODE	WT. KGS.
450	YT-TC-450S	83241	25.0
600	YT-TC-600S	83242	27.3
750	YT-TC-750S	83243	29.5
900	YT-TC-900S	83244	31.8
1050	YT-TC-1050S	83245	34.5
1200	YT-TC-1200S	83246	37.3

Lead time: 2 weeks

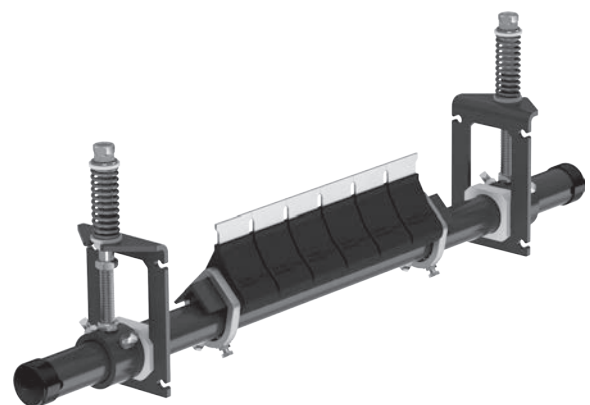

Stock items (non-shaded) refer to (*) for specific lead time, if not specified, standard lead time applies.

 Non-stock items (shaded) please contact Flexco for dispatch options and lead times.

Product Ordering Information

Y-Type™ Heavy Duty Secondary Cleaner with HD Carbide or Urethane Blades

Y-Type™ HD with Purple Polyurethane Blades and YST Tension

BELT WIDTH	ORDERING NUMBER	ITEM CODE	WT. KGS.
900	YTHD-900S	83120	27.1
1050	YTHD-1050S	83121	29.0
1200	YTHD-1200S	83122	30.9
1350	YTHD-1350S	83123	32.8
1500	YTHD-1500S	83124	34.7
1800	YTHD-1800S	83126	38.5

Lead time: 2 weeks

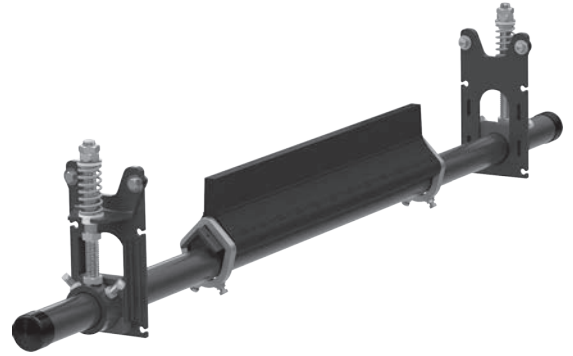

Y-Type™ HD with Carbide Blades and Bolt Tension

BELT WIDTH	ORDERING NUMBER	ITEM CODE	WT. KGS.
900	YTCHD-900	83099	26.9
1050	YTCHD-1050	83100	29.4
1200	YTCHD-1200	83101	31.4
1350	YTCHD-1350	83102	33.4
1500	YTCHD-1500	83103	35.3
1800	YTCHD-1800	83105	39.3

Lead time: 2 weeks

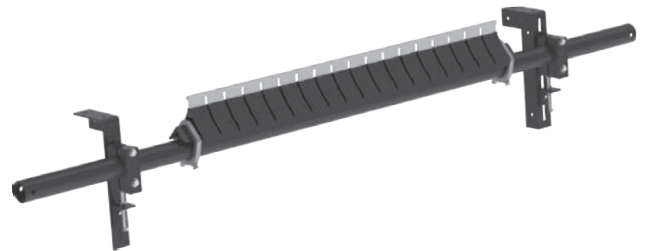



Y-Type™ HD with Carbide Blades and YST Tension

BELT WIDTH	ORDERING NUMBER	ITEM CODE	WT. KGS.
900	YTHD-TC-900S	83134	26.9
1050	YTHD-TC-1050S	83135	29.4
1200	YTHD-TC-1200S	83136	31.4
1350	YTHD-TC-1350S	83137	33.4
1500	YTHD-TC-1500S	83138	35.3
1800	YTHD-TC-1800S	83140	39.3

Lead time: 2 weeks



 Stock items (non-shaded) refer to (*) for specific lead time, if not specified, standard lead time applies.

 Non-stock items (shaded) please contact Flexco for dispatch options and lead times.

Product Ordering Information

Y-Type™ Secondary Cleaner with Carbide or Urethane Blades

Replacment Blades/Cartridges - Standard Duty Carbide

BELT WIDTH	ORDERING NUMBER	ITEM CODE	WT. KGS.
-	YT-C*	79574	0.5
450	YCART-18/450-TC	79811	5.7
600	YCART-24/600-TC	79812	7.5
750	YCART-30/750-TC	79813	9.3
900	YCART-36/900-TC	79814	11.0
1050	YCART-42/1050-TC	79815	12.8
1200	YCART-48/1200-TC	79816	14.5

*Single 75mm (3") blade segment
Lead time: 2 weeks

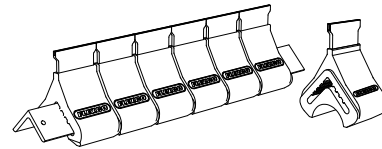

Y-Type™ Standard Duty
Carbide Blade Cartridge

Replacment Blades/Cartridges - Standard Duty Purple Polyurethane

BELT WIDTH	ORDERING NUMBER	ITEM CODE	WT. KGS.
-	YT-P*	79573	0.5
450	YCART-18/450-P	79617	6.0
600	YCART-24/600-P	79618	7.8
750	YCART-30/750-P	79619	9.6
900	YCART-36/900-P	79620	11.4
1050	YCART-42/1050-P	79621	13.2
1200	YCART-48/1200-P	79622	15.0

*Single 75mm (3") blade segment
Lead time: 2 weeks

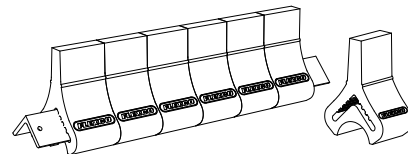

Y-Type™ Standard Duty
Polyurethane Blade Cartridge

Replacment Blades/Cartridges - Heavy-Duty Carbide

BELT WIDTH	ORDERING NUMBER	ITEM CODE	WT. KGS.
-	YT-HDC*	79728	0.8
900	YCART-36/900-HDTC	79829	17.5
1050	YCART-42/1050-HDTC	79830	20.2
1200	YCART-48/1200-HDTC	79831	23.0
1350	YCART-54/1350-HDTC	79832	25.8
1500	YCART-60/1500-HDTC	79833	28.6
1800	YCART-72/1800-HDTC	79834	34.2

*Single 75mm (3") blade segment
Lead time: 2 weeks

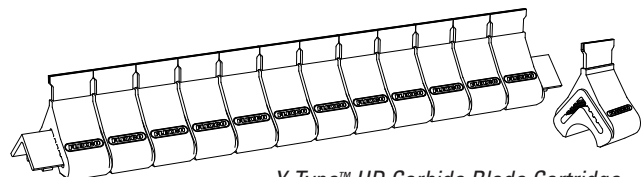

Y-Type™ HD Carbide Blade Cartridge

Replacment Blades/Cartridges - Heavy-Duty Purple Polyurethane

BELT WIDTH	ORDERING NUMBER	ITEM CODE	WT. KGS.
-	YT-HDP*	79677	0.8
900	YCART-36/900-HDP	79817	16.6
1050	YCART-42/1050-HDP	79818	19.2
1200	YCART-48/1200-HDP	79819	21.9
1350	YCART-54/1350-HDP	79820	24.5
1500	YCART-60/1500-HDP	79821	27.2
1800	YCART-72/1800-HDP	79822	32.5

*Single 75mm (3") blade segment
Lead time: 2 weeks

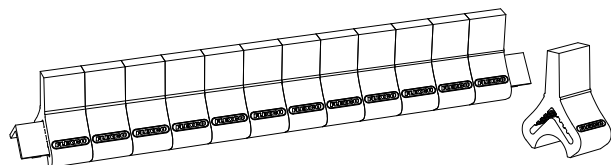

Y-Type™ HD Polyurethane Blade Cartridge

Stock items (non-shaded) refer to (*) for specific lead time, if not specified, standard lead time applies.
Non-stock items (shaded) please contact Flexco for dispatch options and lead times.

Specifications & Guidelines

Y-Type™ Standard Duty Secondary Cleaner with Carbide or Polyurethane Blades

Pole Length Specifications

Cleaner Size		Pole Length		Maximum Conveyor Span	
mm	in.	mm	in.	mm	in.
450	18	1200	48	1025	40
600	24	1350	54	1175	46
750	30	1500	60	1325	52
900	36	1650	66	1475	58
1050	42	1800	72	1625	64
1200	48	1950	78	1775	70

Pole Length - Belt +750mm (30")
Pole Diameter - 60mm (2-3/8")

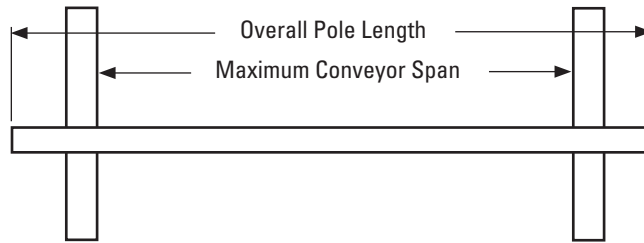

Clearance Guidelines for Installation

Cleaner Type	Belt Width/ Cleaner Size		Horizontal Clearance Required		Vertical Clearance Required		
	mm	in.	mm	in.	mm	in.	
Y-Type® Polyurethane	450 - 1200		18 - 48	110	4-1/4	210	8-1/4
Y-Type Carbide	450 - 1200		18 - 48	110	4-1/4	184	7-3/4

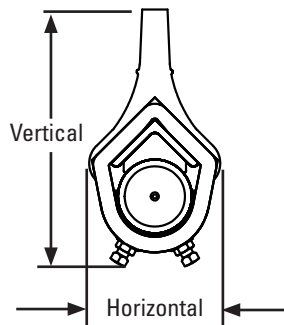

Y-Type Blade Specifications

Cushion	Durometer	Temperature Range
Purple (Standard)	86A	-35° to 82° C -30° to 180° F
Carbide	86A	-35° to 82° C -30° to 180° F

‡ All ingredients used in the Polyurethane formulation of this blade comply with the relevant requirements of 21 CFR (FDA Code of Federal Regulations) for use in repeated bulk dry food applications

Spring Length Chart

Blade Width		Carbide Tip		Polyurethane Tip			
		Silver Springs		Yellow Springs		Purple Springs	
mm	in.	mm	in.	mm	in.	mm	in.
450	18	105	4 1/8	83	3 1/4	92	3 5/8
600	24	102	4	73	2 7/8	86	3 3/8
750	30	98	3 7/8	67	2 5/8	79	3 1/8
900	36	95	3 3/4	57	2 1/4	73	2 7/8
1050	42	92	3 5/8	NA	NA	67	2 5/8
1200	48	89	3 1/2	NA	NA	60	2 3/8

Shading indicates preferred spring option.

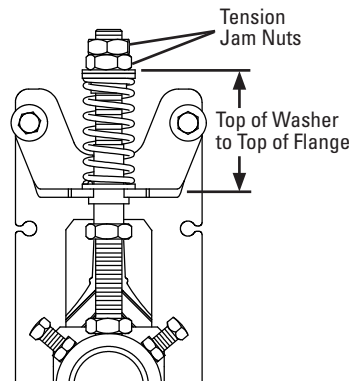

Pull-Up Tensioner Configuration (SD)

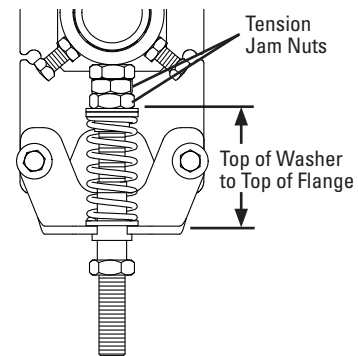

Push-Up Tensioner Configuration (SD)

Specifications:

- Maximum Belt Speed.....3M/sec (600 FPM)
- Temperature Rating.....-35°C to 82°C (-30°F to 180°F)
- Usable Blade Wear Length.....50mm (2") (Polyurethane)
6mm (1/4") (Carbide)
- Blade Materials.....**Purple:** Polyurethane (proprietary blend for abrasion resistance and long wear)
Carbide: Tungsten Carbide
- Available for Belt Widths.....450 to 1200mm (18" to 48"). Other sizes available upon request.
- CEMA Cleaner Rating.....Class 2 (Standard-duty with polyurethane blades)
Class 3 (Standard-duty with carbide blades)

Specifications & Guidelines

Y-Type™ Heavy Duty Secondary Cleaner with HD Carbide or Urethane Blades

Pole Length Specifications

Cleaner Size		Pole Length		Maximum Conveyor Span	
mm	in.	mm	in.	mm	in.
900	36	2286	90	2083	82
1050	42	2438	96	2235	88
1200	48	2590	102	2388	94
1350	54	2743	108	2540	100
1500	60	2895	114	2692	106
1800	72	3200	126	2997	118

Pole Length - Belt +1350mm (54")
Pole Diameter - 73mm (2-7/8")

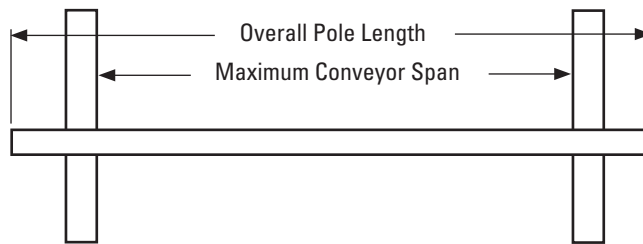

Clearance Guidelines for Installation

Cleaner Type	Belt Width/ Cleaner Size		Horizontal Clearance Required		Vertical Clearance Required	
	mm	in.	mm	in.	mm	in.
Y-Type® HD Polyurethane	900 - 1800	36 - 72	133	5-1/4	241	9-1/2
Y-Type HD Carbide	900 - 1800	36 - 72	133	5-1/4	248	9-3/4

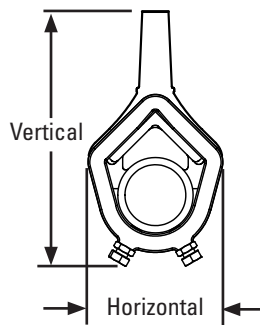

Y-Type Blade Specifications

Cushion	Durometer	Temperature Range
Purple (Standard)	86A	-35° to 82° C -30° to 180° F
Carbide	86	-35° to 82° C -30° to 180° F

‡ All ingredients used in the polyurethane formulation of this blade comply with the relevant requirements of 21 CFR (FDA Code of Federal Regulations) for use in repeated bulk dry food applications

Blade Width	Carbide Tip				Polyurethane Tip				
	Silver Springs		Black Springs		Green Springs		Blue Springs		
mm	in.	mm	in.	mm	in.	mm	in.	mm	in.
900	36	98	3 7/8	102	4	76	3	86	3 3/8
1050	42	95	3 3/4	98	3 7/8	73	2 7/8	83	3 1/4
1200	48	92	3 5/8	95	3 3/4	67	2 5/8	79	3 1/8
900	54	89	3 1/2	95	3 3/4	64	2 1/2	76	3
1050	60	86	3 3/8	92	3 5/8	NA	NA	73	2 7/8
1200	72	83	3 1/4	89	3 1/2	NA	NA	64	2 1/2

Shading indicates preferred spring option.

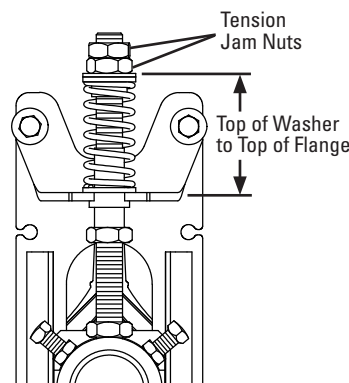

Pull-Up Tensioner Configuration (HD)

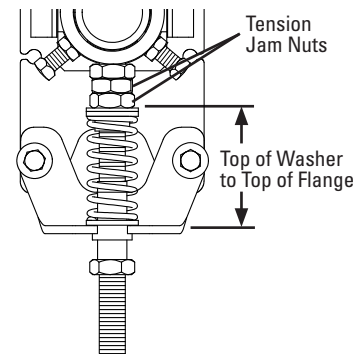

Push-Up Tensioner Configuration (HD)

Specifications:

- Maximum Belt Speed.....3.8M/sec (750 FPM)
- Temperature Rating.....-35°C to 82°C (-30°F to 180°F)
- Usable Blade Wear Length.....75mm (3") (Polyurethane)
10mm (3/8") (Carbide)
- Blade Materials.....**Purple:** Polyurethane (proprietary blend for abrasion resistance and long wear)
Carbide: Tungsten Carbide
- Available for Belt Widths.....900 to 1800mm (36" to 72"). Other sizes available upon request.
- CEMA Cleaner Rating.....Class 3 (Heavy-duty with polyurethane or carbide blades)

Replacement Parts List

Y-Type™ Standard Duty Secondary Cleaner with Carbide or Polyurethane Blades

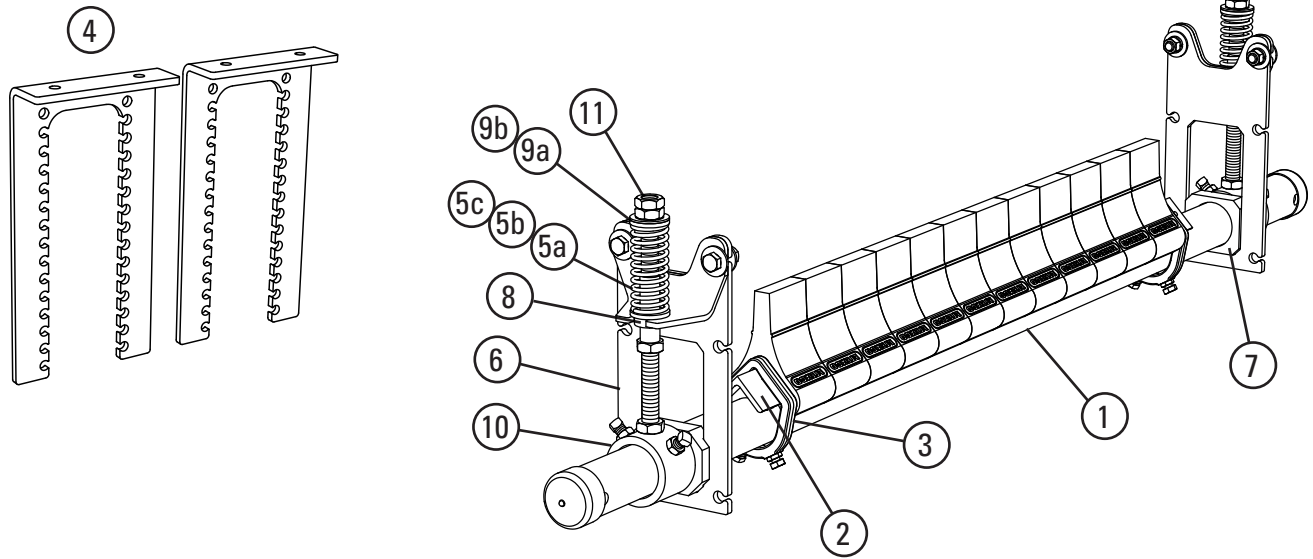

Replacement Parts

REF	DESCRIPTION	ORDERING NUMBER	ITEM CODE	WT. KG.
1	450mm (18") Y-Type™ Pole	YTP-18/450	82932	9.2
	600mm (24") Y-Type Pole	YTP-24/600	82933	10.3
	750mm (30") Y-Type Pole	YTP-30/750	82934	11.5
	900mm (36") Y-Type Pole	YTP-36/900	82935	12.6
	1050mm (42") Y-Type Pole	YTP-42/1050	82936	13.7
	1200mm (48") Y-Type Pole	YTP-48/1200	82937	14.9
2	450mm (18") Y-Type Cushion Angle	YTA-18/450	82949	2.6
	600mm (24") Y-Type Cushion Angle	YTA-24/600	82950	3.3
	750mm (30") Y-Type Cushion Angle	YTA-30/750	82951	4.0
	900mm (36") Y-Type Cushion Angle	YTA-36/900	82952	4.7
	1050mm (42") Y-Type Cushion Angle	YTA-42/1050	82953	5
	1200mm (48") Y-Type Cushion Angle	YTA-48/1200	82954	6.2
3	Y-Type Angle Clamp* (2 Clamps)	YTAC	79623	1.0
4	YST Drop Bracket Kit (2 Brackets)	YSTDBK	79844	9.0
5a	YST Spring Yellow	YSTS-Y	79795	0.1
5b	YST Spring Purple	YSTS-P	79796	0.2
5c	YST Spring Silver (Y-Type Carbide Cleaners)	CTS-S	77743	0.2
6	YST Mounting Bracket (incl. Angle Bracket)	YSTMB	79843	1.5
7	YST Guide Block Kit (Pair)	YSTGBK	79845	0.2
8	YST Lower Bushing Kit (Pair)	YSTLBK	79846	0.0
9a	YST Top Bushing Kit White (Pair)	YSTTBK-W	79847	0.0
9b	YST Top Bushing Kit Black (Pair)	YSTTBK-B	79855	0.0
10	YST Pole Mount Kit*	YSTPMK	79848	2.0
11	YST Adjusting Rod Nut Kit	YSTANK	79857	0.1

*Hardware included
Lead time: 2 weeks

Replacement Parts

REF	DESCRIPTION	ORDERING NUMBER	ITEM CODE	WT. KG.
-	YST Tensioner w/Yellow Spring (Pair) (incl. 2 ea. item 5a, 6, 10, 11; 1 ea. items 7, 8, 9a)	YST-Y	79836	8.3
-	YST Tensioner w/Purple Spring (Pair) (incl. 2 ea. item 5b, 6, 10, 11; 1 ea. items 7, 8, 9a)	YST-P	79837	8.4
-	YST Tensioner w/Silver Spring (Pair) (incl. 2 ea. item 5c, 6, 10, 11; 1 ea. items 7, 8, 9b)	YST-S	79838	8.5
-	P Adjusting Bracket	PAB	75513	1.0
-	P Pole Clamp	PCB	75507	3.0
-	P Mounting Bracket Repair Kit (includes left or right mounting bracket)	PMBL (left) PMBR (right)	75516 75519	3.8 3.8
-	P/R/I Mounting Kit (includes 2 each items PMB, PAB, PCB)	P/RMK	73025	12

Lead time: 2 weeks

Blades Required per Cleaner Size

mm	450	600	750	900	1050	1200
in.	18	24	30	36	42	48
Blades Required	6	8	10	12	14	16

Spring Tensioner Selection Chart

Cleaner Blade Width	79838 YST-S	79836 YST-Y	79837 YST-P
Carbide 450 - 1200mm (18" - 48")	X		
Polyurethane 450 - 750mm (18" - 30")		X	
Polyurethane 900 - 1200mm (36" - 48")			X

Stock items (non-shaded) refer to (*) for specific lead time, if not specified, standard lead time applies.

Non-stock items (shaded) please contact Flexco for dispatch options and lead times.

Replacement Parts List

Y-Type™ Heavy Duty Secondary Cleaner with HD Carbide or Urethane Blades

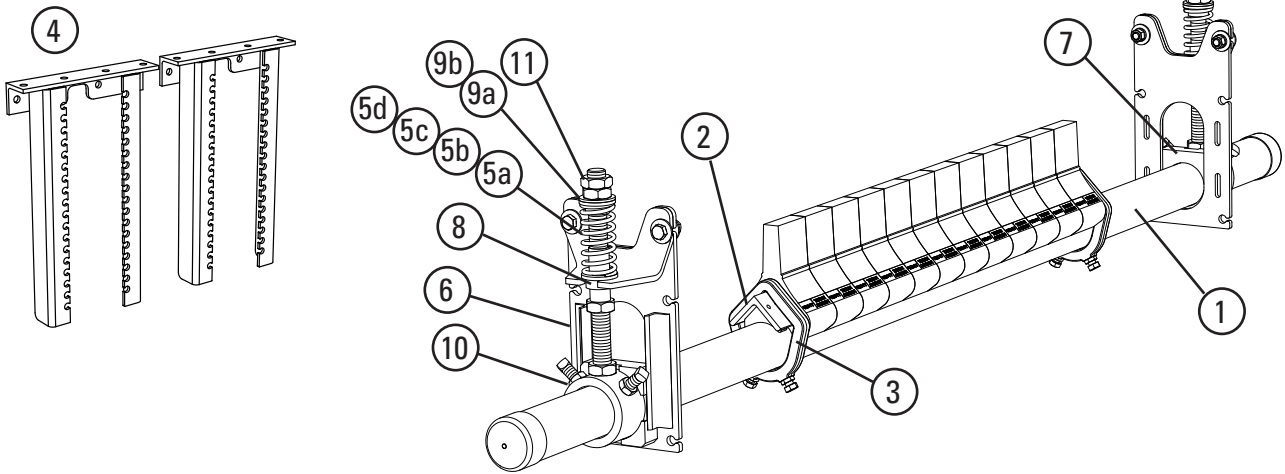

Replacement Parts

REF	DESCRIPTION	ORDERING NUMBER	ITEM CODE	WT. KG.
1	900mm (36") Y-Type™ HD Pole	YTPHD-36/900	83106	27.3
	1050mm (42") Y-Type HD Pole	YTPHD-42/1050	83107	28.8
	1200mm (48") Y-Type HD Pole	YTPHD-48/1200	83108	30.4
	1350mm (54") Y-Type HD Pole	YTPHD-54/1350	83109	31.9
	1500mm (60") Y-Type HD Pole	YTPHD-60/1500	83110	33.5
	1800mm (72") Y-Type HD Pole	YTPHD-72/1800	83112	35.0
2	900mm (36") Y-Type HD Cushion Angle	YTAHD-36/900	79805	7.5
	1050mm (42") Y-Type HD Cushion Angle	YTAHD-42/1050	79806	8.6
	1200mm (48") Y-Type HD Cushion Angle	YTAHD-48/1200	79807	9.7
	1350mm (54") Y-Type HD Cushion Angle	YTAHD-54/1350	79808	10.9
	1500mm (60") Y-Type HD Cushion Angle	YTAHD-60/1500	79809	12.0
	1800mm (72") Y-Type HD Cushion Angle	YTAHD-72/1800	79810	14.2
3	Y-Type HD Angle Clamp* (2 Clamps)	YTACHD	79835	2.2
4	YST HD Drop Bracket Kit (2 Brackets)	YSTDDBK	79850	14.6
5a	YST HD Spring, Green	YSTDHS-GR	79797	0.2
5b	SST Spring, Silver	STS-S	75843	0.4
5c	YST HD Spring, Blue (for Y-Type HD Carbide Cleaners)	YSTDHS-BL	79798	0.3
5d	SST Spring, Black (for Y-Type HD Carbide Cleaners)	STS-B	75844	0.5
6	YST HD Mounting Bracket	YSTDHMB	79849	3.0
7	YST HD Guide Block Kit (Pair)	YSTDHGBK	79851	0.5
8	YST HD Lower Bushing Kit (Pair)	YSTDHLBK	79852	0.0
9a	YST HD Top Bushing Kit White (Pair)	YSTDHBK-W	79853	0.0
9b	YST HD Top Bushing Kit Black (Pair)	YSTDHBK-B	79856	0.0
10	YST HD Pole Mount Kit*	YSTDHDMK	79854	3.5
	Pole Adjusting Rod Nut Kit	YSTANK	79858	0.1

Spring Tensioner Selection Chart

Cleaner Blade Width	Silver YSTHD-S	Black YSTHD-BK	Green YSTHD-GR	Blue YSTHD-BL
Carbide 900 - 1350mm (36" - 54")	X			
Carbide 1500 - 1800mm (60" - 72")		X		
Polyurethane 900 - 1200mm (36" - 48")			X	
Polyurethane 1350 - 1800mm (54" - 72")				X

Replacement Parts

REF	DESCRIPTION	ORDERING NUMBER	ITEM CODE	WT. KG.
-	YST Tensioner w/Silver Spring (Pair) (for belts 36" - 54" w/carbide tips) (incl. 2 ea. item 5b, 6, 10, 11; 1 ea. items 7, 8, 9a)	YSTHD-S	79840	15.2
-	YST Tensioner w/Black Spring (Pair) (for belts 60" - 72" w/carbide tips) (incl. 2 ea. item 5d, 6, 10, 11; 1 ea. items 7, 8, 9b)	YSTHD-BK	79842	15.5
-	YST Tensioner w/Green Spring (Pair) (for belts 36" - 48" w/Polyurethane tips) (incl. 2 ea. item 5a, 6, 10, 11; 1 ea. items 7, 8, 9a)	YSTHD-GR	79839	14.9
-	YST Tensioner w/Blue Spring (Pair) (for belts 54" - 72" w/Polyurethane tips) (incl. 2 ea. item 5c, 6, 10, 11; 1 ea. items 7, 8, 9b)	YSTHD-BL	79841	15.0
-	P Adjusting Bracket	PAB	75513	1.0
-	P Pole Clamp	PHDCB	75510	4.0
-	P Mounting Bracket Repair Kit (includes left or right mounting bracket)	PMBL (left)	75516	3.8
-		PMBR (right)	75519	3.8
-	P/R/I Mounting Kit (includes P, R, I)	PIHMK	73160	14

Blades Required per Cleaner Size

mm	900	1050	1200	1350	1500	1800
in.	36	42	48	54	60	72
Blades Required	12	14	16	18	20	24

Stock items (non-shaded) refer to (*) for specific lead time, if not specified, standard lead time applies.

Non-stock items (shaded) please contact Flexco for dispatch options and lead times.

Product Ordering Information

P-Type® Secondary Cleaner

P-Type® Secondary with V-Tips* Powder Coated

BELT WIDTH mm	ORDERING NUMBER	ITEM CODE	WT. KG.
450	PV450	73435	36.0
600	PV600	73004	37.0
750	PV750	73006	38.0
900	PV900	73008	41.0
1050	PV1050	73010	47.0
1200	PV1200	73012	51.0
1400	PV1400	73436	55.0
1500	PV1500	73437	58.0
1800	PVHD1800	74598	92.0
2000	PVHD2000	75452	96.0
2100	PVHD2100	74553	100.0
2400	PVHD2400	74555	110.0

*NOTE: V-Tips can be used ONLY on vulcanised belts. P-Type cleaners come standard with bolt tensioners. Shaded items are made to order-contact Flexco customer service.



P-Type® Secondary with V-Tips* Stainless Steel

BELT WIDTH mm	ORDERING NUMBER	ITEM CODE	WT. KG.
450	PV450-S/S	75323	37.0
600	PV600-S/S	75324	38.0
750	PV750-S/S	75325	39.0
900	PV900-S/S	75326	42.0
1050	PV1050-S/S	75327	48.0
1200	PV1200-S/S	75328	52.0
1400	PV1400-S/S	75329	56.0
1500	PV1500-S/S	75330	60.0
1800	PVHD1800-S/S	A1603	95.0
2000	PVHD2000-S/S	A2046	99.0
2100	PVHD2100-S/S	A1604	103.0
2400	PVHD2400-S/S	A1605	114.0

*NOTE: V-Tips can be used ONLY on vulcanised belts. P-Type cleaners come standard with bolt tensioners. Shaded items are made to order-contact Flexco customer service.

Tips Required Per Cleaner Size

BELT WIDTH mm	BLADE COVERAGE mm	V-TIPS REQUIRED
450	450	3
600	600	4
750	750	5
900	900	6
1050	1050	7
1200	1200	8
1400	1350	9
1500	1500	10
1800	1800	12
2000	1950	13
2100	2100	14
2400	2400	16

Product Notes:

- C-Tip: specially formulated tungsten carbide blades to work with mechanical fasteners.
- V-Tip: for use on vulcanised belts only.
- Compact design: fits in small transfer areas and tight chutes.

Stock items (non-shaded) refer to (*) for specific lead time, if not specified, standard lead time applies.

Non-stock items (shaded) please contact Flexco for dispatch options and lead times.

Replacement Parts List

P-Type®
Secondary Cleaner

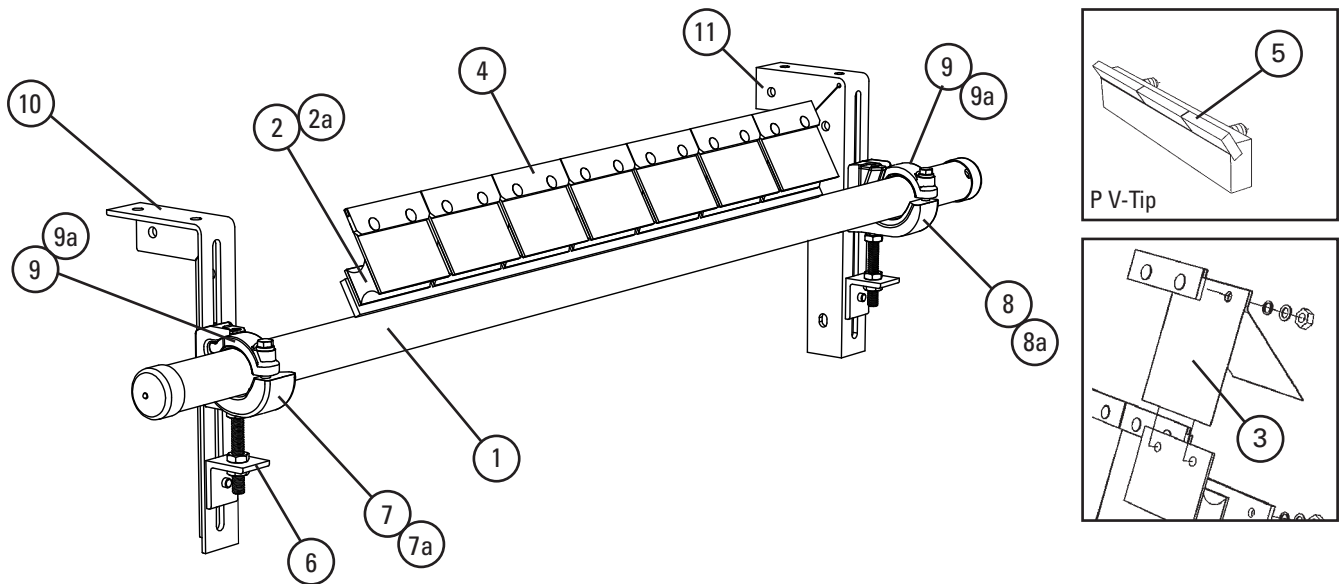

Replacement Parts

REF	DESCRIPTION	POWDER COATED					STAINLESS STEEL		
		BELT WIDTH	POLE LENGTH (MM)	ORDERING NUMBER	ITEM CODE	WT. KG.	ORDERING NUMBER	ITEM CODE	WT. KG.
1	P-Type® Pole 60 mm Pole Diameter	450	1250	PP450	73003	10.0	PP450-S/S	75382	10.0
		600	1350	PP600	73005	11.0	PP600-S/S	75383	11.0
		750	1500	PP750	73007	13.0	PP750-S/S	75384	13.0
		900	1650	PP900	73009	15.0	PP900-S/S	75385	15.0
		1050	1800	PP1050	73011	20.0	PP1050-S/S	75386	21.0
	P-Type Pole 73 mm Pole Diameter	1200	1950	PP1200	73013	20.0	PP1200-S/S	75387	23.0
		1400	2200	PP1400	73015	24.0	PP1400-S/S	75388	25.0
		1500	2350	PP1500	73016	25.0	PP1500-S/S	75389	26.0
		1800	2650	PPHD1800	74597	27.0	PPHD1800-S/S	A1781	28.0
		2000	2850	PPHD2000	74556	31.0	PPHD2000 -S/S	A2120	29.0
	2100	2950	PPHD2100	A2803	38.0	PPHD2100 -S/S	A1613	39.0	
	2400	3250	PPHD2400	74557	44.0	PPHD2400 -S/S	A1775	45.0	
2	P Cushion			PHA	73626	1.0	PHSC-S/S	73433	1.0
2a	P-Type Powerflex Cushion						PFC-P-S/S	79289	1.9
3	P Polyshield			PPS6	73024	1.0	PSSS	74773	1.0
-	PU-Tip (Polyurethane Tip for Fastened Belts)			PU150	73020	1.0			
4	C-Tip (for mechanically spliced and vulcanised belts)			CT6	74535	0.4			
5	P V-Tip* (for vulcanised belts only)			PSA150	73156	0.4	PVT6-S/S	75420	0.4
6	Adjusting Bracket Kit* (1ea.)			PAB	75513	0.7	PAB-S/S	75515	0.7
7	Pole Clamp Kit Left* (1ea.) (incl. item 9) (for sizes 450-1200mm)			CCKL	79224	3.1	CCKL-S/S	79226	3.1
8	Pole Clamp Kit Right* (1ea.) (incl. item 9) (for sizes 450-1200mm)			CCKR	79228	3.1	CCKR-S/S	79230	3.1
9	Cradle Clamp Top Strap (1ea.) (for use on L or R Pole Clamp Kit)			CCKTS	79232	0.5	CCKTS-S/S	79234	0.5
10	Mounting Bracket Kit Left			PMBL (left)	75516	3.8	PMBL-S/S (left)	75518	3.8
11	Mounting Bracket Kit Right			PMBL (right)	75519	3.8	PMBL-S/S (right)	75521	3.8
-	Cradle Clamp Mounting Kit* (for sizes 450-1200mm) (incl. 2 ea. item 6, and 1 ea. Items 7, 8, 10 & 11)			CCMK	78919	15.0	CCMK-S/S	78921	15.0
HEAVY-DUTY COMPONENTS									
7a	HD Pole Clamp Kit Left* (1ea.) (incl. item 9a) (for sizes 1200-2400mm)			CCKHDL	79225	4.0	CCKHDL-S/S	79227	4.0
8a	HD Pole Clamp Kit Right* (1ea.) (incl. item 9a) (for sizes 1200-2400mm)			CCKHDR	79229	4.0	CCKHDR-S/S	79231	4.0
9a	HD Cradle Clamp Top Strap (1ea.) (for use on L or R HD Pole Clamp Kit)			CCKHDTS	79233	0.8	CCKHDTS-S/S	73235	0.8
-	HD Cradle Clamp Mounting Kit* (for sizes 1200-2400mm) (incl. 2 ea. item 6, and 1 ea. Items 7, 8, 10 & 11)			CCMKHD	78920	16.7	CCMKHD-S/S	78922	16.7

*Hardware included

Product Ordering Information

R-Type® Reversing Secondary Cleaner

R-Type® Reversing with V-Tips*

BELT WIDTH mm	ORDERING NUMBER	ITEM CODE	WT. KG.
450	RV450	74633	36.0
600	RV600	74634	37.0
750	RV750	74635	38.0
900	RV900	74636	41.0
1050	RV1050	74637	47.0
1200	RV1200	74638	51.0
1400	RV1400	74639	55.0
1500	RV1500	74640	28.0
1800	RVHD1800	74642	92.0
2000	RVHD2000	75463	94.0
2100	RVHD2100	74643	100.0
2400	RVHD2400	74644	110.0

*NOTE: V-Tips can be used ONLY on vulcanised belts.
Shaded items are made to order-contact Flexco® customer service.



Stainless Steel R-Type® Reversing with V-Tips*

BELT WIDTH mm	ORDERING NUMBER	ITEM CODE	WT. KG.
450	RV450-S/S	75341	37.0
600	RV600-S/S	75342	38.0
750	RV750-S/S	75343	39.0
900	RV900-S/S	75344	42.0
1050	RV1050-S/S	75345	48.0
1200	RV1200-S/S	75346	57.0
1400	RV1400-S/S	75347	56.0
1500	RV1500-S/S	75348	60.0
1800	RVHD1800-S/S	A1626	95.0
2100	RVHD2100-S/S	A1628	103.0
2400	RVHD2400-S/S	A1610	114.0

*NOTE: V-Tips can be used ONLY on vulcanised belts.
Shaded items are made to order-contact Flexco customer service.

Tips Required Per Cleaner Size

BELT WIDTH mm	BLADE COVERAGE mm	C-TIPS OR V-TIPS REQUIRED
450	450	3
600	600	4
750	750	5
900	900	6
1050	1050	7
1200	1200	8
1500	1500	10
1800	1800	12
2000	1950	13
2100	2000	14
2400	2400	16

Product Notes:

- Two-way cushions allow cleaning in both directions.
- Tungsten carbide tips for long wear and superior cleaning.

Stock items (non-shaded) refer to (*) for specific lead time, if not specified, standard lead time applies.

Non-stock items (shaded) please contact Flexco for dispatch options and lead times.

Replacement Parts List

R-Type®
Reversing Secondary Cleaner

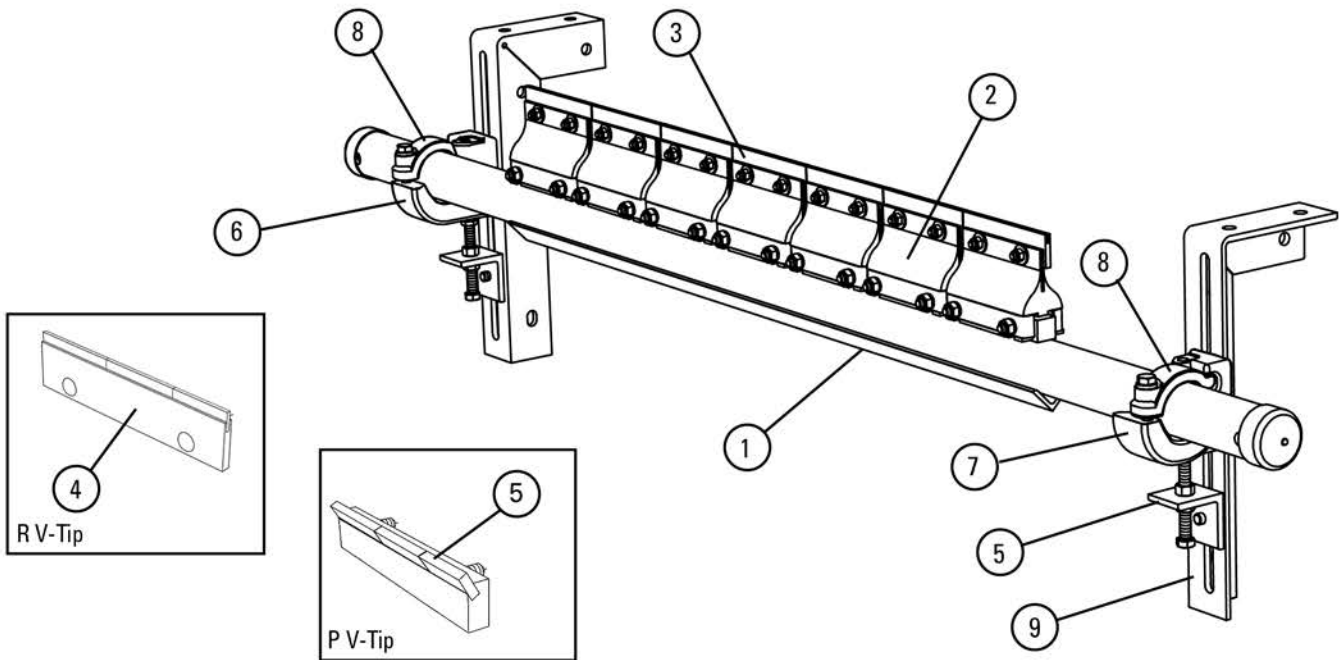

Replacement Parts

REF	DESCRIPTION	POWDER COATED					STAINLESS STEEL		
		BELT WIDTH	POLE LENGTH (MM)	ORDERING NUMBER	ITEM CODE	WT. KG.	ORDERING NUMBER	ITEM CODE	WT. KG.
1	R-Type® Pole 60 mm Pole Diameter	450	1250	RP450	74604	10.0	RP450-S/S	75400	10.0
		600	1350	RP600	74605	11.0	RP600-S/S	75401	11.0
		750	1500	RP750	74606	13.0	RP750-S/S	75402	13.0
		900	1650	RP900	74607	15.0	RP900-S/S	75403	15.0
		1050	1800	RP1050	74608	20.0	RP1050-S/S	75404	21.0
		1200	1950	RP1200	74609	22.0	RP1200-S/S	75405	23.0
	R-Type Pole 73 mm Pole Diameter	1400	2200	RP1400	74610	24.0	RP1400-S/S	75406	25.0
		1500	2350	RP1500	74611	25.0	RP1500-S/S	75407	26.0
		1800	2650	RPHD1800	74613	27.0	RPHD1800-S/S	A1575	28.0
		2000	2850	RPHD2000	74614	31.0	RPHD2000-S/S	61270	29.0
		2100	2950	RPHD2100	A2527	38.0	RPHD2100-S/S	A1629	39.0
		2400	3250	RPHD2400	74615	44.0	RPHD2400-S/S	61271	45.0
2	R Cushion			RSA	76249	1.0	RC-S/S	76250	1.0
3	R - V-Tip (for vulcanised belts only)			RSA150	73628	0.4	RVT6-S/S	76205	0.4
4	C-Tip (for mechanically spliced and vulcanised belts)			CT6	74535	0.4			
5	P V-Tip* (for vulcanised belts only)			PSA150	73156	0.4	PVT6-S/S	75420	0.4
6	Adjusting Bracket Kit* (1ea.)			PAB	75513	0.7	PAB-S/S	75515	0.7
7	Pole Clamp Kit Left* (1ea.) (incl. item 9) (for sizes 450-1200mm)			CCKL	79224	3.1	CCKL-S/S	79226	3.1
8	Pole Clamp Kit Right* (1ea.) (incl. item 9) (for sizes 450-1200mm)			CCKR	79228	3.1	CCKR-S/S	79230	3.1
9	Cradle Clamp Top Strap (1ea.) (for use on L or R Pole Clamp Kit)			CCKTS	79232	0.5	CCKTS-S/S	79234	0.5
10	Mounting Bracket Kit Left			PMBL (left)	75516	3.8	PMBL-S/S (left)	75518	3.8
11	Mounting Bracket Kit Right			PMBL (right)	75519	3.8	PMBL-S/S (right)	75521	3.8
-	Cradle Clamp Mounting Kit* (for sizes 450-1200mm) (incl. 2 ea. item 6, and 1 ea. Items 7, 8, 10 & 11)			CCMK	78919	15.0	CCMK-S/S	78921	15.0
Heavy-Duty Components									
7a	HD Pole Clamp Kit Left* (1ea.) (incl. item 9a) (for sizes 1200-2400mm)			CCKHDL	79225	4.0	CCKHDL-S/S	79227	4.0
8a	HD Pole Clamp Kit Right* (1ea.) (incl. item 9a) (for sizes 1200-2400mm)			CCKHDR	79229	4.0	CCKHDR-S/S	79231	4.0
9a	HD Cradle Clamp Top Strap (1ea.) (for use on L or R HD Pole Clamp Kit)			CCKHDTS	79233	0.8	CCKHDTS-S/S	73235	0.8
-	HD Cradle Clamp Mounting Kit* (for sizes 1200-2400mm) (incl. 2 ea. item 6, and 1 ea. items 7, 8, 10 & 11)			CCMKHD	78920	16.7	CCMKHD-S/S	78922	16.7

*Hardware included
For additional sizes contact Flexco®.

Product Ordering Information

MHS - MST Heavy Duty Secondary Cleaner

MHS HD with MST Tensioner - Mild Steel

BELT WIDTH	ORDERING NUMBER	ITEM CODE	TIP WIDTH	POLE LENGTH	WT. KG.
mm			mm	mm	
600	MHS-600-MST	64020	600	1350	44.4
750	MHS-750-MST	64021	750	1500	49.3
900	MHS-900-MST	64022	900	1650	54.3
1050	MHS-1050-MST	64023	1050	1800	59.2
1200	MHS-1200-MST	64024	1200	1950	64.1
1350	MHS-1350-MST	64025	1350	2100	69
1500	MHS-1500-MST	64026	1500	2350	73.9
1800	MHS-1800-MST	64027	1800	2650	83.6
2100	MHS-2100-MST	64028	2100	3200	95.7
2400	MHS-2400-MST	64029	2400	3250	103.2



MHS HD with MST Tensioner - Stainless Steel

BELT WIDTH	ORDERING NUMBER	ITEM CODE	TIP WIDTH	POLE LENGTH	WT. KG.
mm			mm	mm	
600	MHS-600-MST-S/S	64030	600	1350	44.9
750	MHS-750-MST-S/S	64031	750	1500	49.8
900	MHS-900-MST-S/S	64032	900	1650	54.8
1050	MHS-1050-MST-S/S	64033	1050	1800	59.7
1200	MHS-1200-MST-S/S	64034	1200	1950	64.6
1350	MHS-1350-MST-S/S	64035	1350	2100	69.5
1500	MHS-1500-MST-S/S	64036	1500	2350	74.4
1800	MHS-1800-MST-S/S	64037	1800	2650	84.1
2100	MHS-2100-MST-S/S	64038	2100	3200	96.2
2400	MHS-2400-MST-S/S	64039	2400	3250	103.7

Product Notes:

- Heavy-duty design to deliver maximum cleaning efficiency on the most demanding, abusive beltlines.
- Pole Length: Belt width plus 1350mm (54"). For longer requirements, see accessories - Pole Extender Kit (page 124).
- Patented PowerFlex™ cushion design to maintain continuous blade-to-belt contact and quick relief from passing mechanical splices.
- V-Tips are for vulcanized belts only.
- Visual Blade Tension Check: Measure the tension spring and refer to Spring Length Chart on mounting base for the correct length for best cleaning performance.
- Tensioner: MST Spring Tensioner for self-adjusting tensioning with easy retensioning adjustments.
- To make cleaner installation easier and quicker, see Optional Mounting Kits (page 124).

Stock items (non-shaded) refer to (*) for specific lead time, if not specified, standard lead time applies.

Non-stock items (shaded) please contact Flexco for dispatch options and lead times.

Replacement Parts List

MHS - MST Heavy Duty Secondary Cleaner

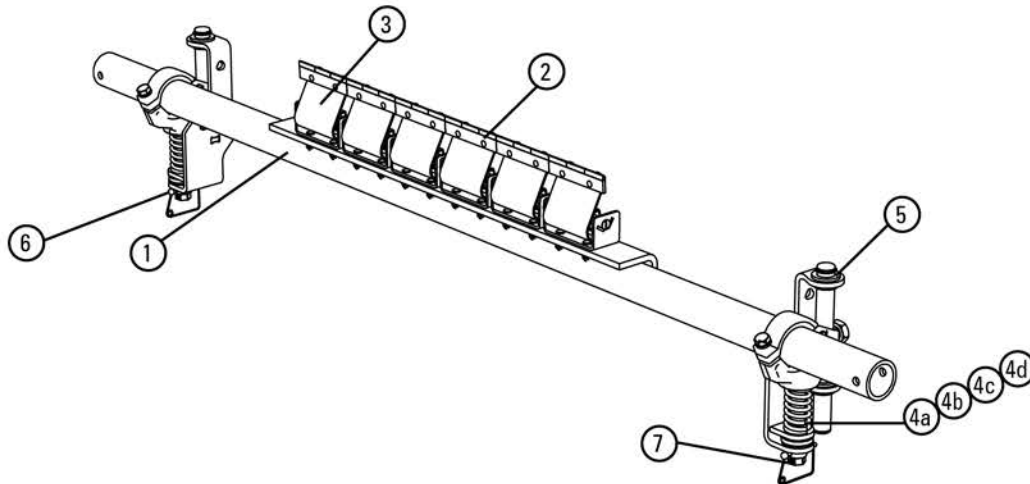

Replacement Parts

REF	DESCRIPTION		MILD STEEL			STAINLESS STEEL		
			ORDERING NUMBER	ITEM CODE	WT. KG.	ORDERING NUMBER	ITEM CODE	WT. KG.
	BELT WIDTH mm	POLE LENGTH mm						
1	600	1350	MHS-P600	77499	23.5	MHS-P600S/S	77508	24.0
	750	1500	MHS-P750	77500	26.0	MHS-P750S/S	77509	26.5
	900	1650	MHS-P900	77501	28.5	MHS-P900S/S	77510	29.0
	1050	1800	MHS-P1050	77502	31.0	MHS-P1050S/S	77511	31.7
	1200	1950	MHS-P1200	77527	33.5	MHS-P1200S/S	77528	34.3
	1350	2100	MHS-P1350	77503	36.0	MHS-P1350S/S	77512	36.8
	1500	2350	MHS-P1500	77504	38.5	MHS-P1500S/S	77513	39.3
	1800	2650	MHS-P1800	77505	43.5	MHS-P1800S/S	77514	44.4
	2100	3200	MHS-P2100	77506	51.0	MHS-P2100S/S	77515	52.0
	2400	3250	MHS-P2400	77507	58.0	MHS-P2400S/S	77516	59.3
2	C-Tip (suits mechanical fastened belt)		CT6	74535	.4	N/A	N/A	—
	V-Tip (suits vulcanised belt)		RSA150	73628	.4	RVT6-S/S	76205	.4
3	PowerFlex™ Cushion		SPFC	79200	2.0	SPFC-S/S	79201	2.0
4a	Tension Spring - White (1 ea.) for belts 450-750mm		STS-W	75846	0.2	STS-W-S/S	77630	0.2
4b	Tension Spring - Silver (1 ea.) for belts 900-1350mm		STS-S	75843	0.4	STS-S-S/S	77631	0.4
4c	Tension Spring - Black (1 ea.) for belts 1500-1800mm		STS-B	75844	0.5	STS-B-S/S	77632	0.5
4d	Tension Spring - Gold (1 ea.) for belts over 2100mm		STS-G	78142	0.5	STS-G-S/S	79057	0.5
5	MST Bushing Kit (incl. 4 bushings)		MSTBK	79440	0.1	MSTBK	79440	0.1
6	MST Lock Pin		MSTLP	64930	0.1	MSTLP	64930	0.1
7	MST Adjustment Mechanism		MSTAM	79435	0.5	MSTAM-S/S	64931	0.5
-	MST HD Tensioner w/White Spring		MSTHD-W	79431	16.7	MSTHD-SS-W	90181	16.7
-	MST HD Tensioner w/Silver Spring		MSTHD-S	79432	17.0	MSTHD-SS-S	90182	17.0
-	MST HD Tensioner w/Black Spring		MSTHD-B	79433	17.3	MSTHD-SS-B	90183	17.3
-	MST HD Tensioner w/Gold Spring		MSTHD-G	63020	17.3	MSTHD-SS-G	90184	17.3

MST Spring Tensioner Selection Chart

CLEANER SIZE	White Spring	Silver Spring	Black Spring	Gold Spring
MHS 450 - 750mm	X			
MHS 900 - 1350mm		X		
MHS 1500 - 1800mm			X	
MHS 1800 - 2400mm				X

Stock items (non-shaded) refer to (*) for specific lead time, if not specified, standard lead time applies.

Non-stock items (shaded) please contact Flexco for dispatch options and lead times.

Replacement Parts List

MHS - MST Heavy Duty Secondary Cleaner

ATV Replacement Parts

REF	DESCRIPTION	ORDERING NUMBER	ITEM CODE	WT. KG.
1	Mounting Bracket LH	PMBL-S/S	75518	3.8
2	Mounting Bracket RH	PMBR-S/S	75521	3.8
3	Air Tensioner Slider	ATV-SLIDE	62425	0.2
4	Air Tension Cradle Blocks 60mm Kit	ATV-MOUNT	62424	2.4
5	Air Tension Cradle Blocks 73mm Kit	ATV-MOUNT	63073	2.4
6	Air Tension Adjusting Angle	ATV-ANGLE	62426	1.0
7	Air Bag	ATV-BAG	62036	0.2
8	Hex Nut S/S	HEX NUT	G1211	0.1
9	Air Line Adaptor	ATV-NIP	62037	0.1
10	PAT Control Box 60psi	PACB60	78683	5.0
11	PAT Control Box 100psi	PACB100	79656	5.0
-	Secondary Air Tension 60mm Complete Kit	ATVK-60	62409	13.0
-	Secondary Air Tension 73mm Complete Kit	ATVK-73	63072	15.0

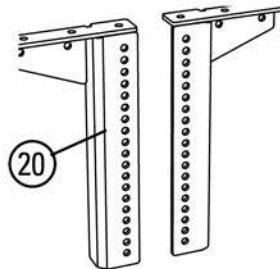
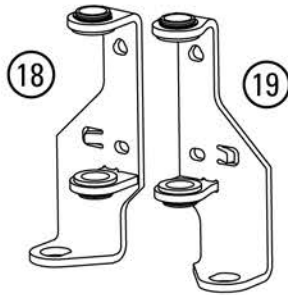
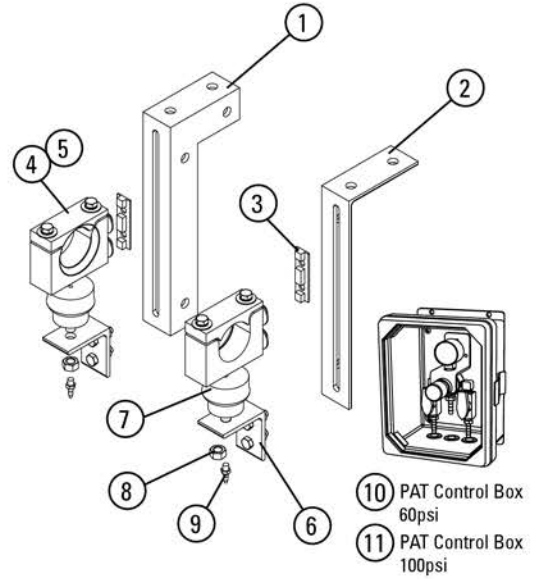

MST Tensioner Replacement Parts

REF	DESCRIPTION	ORDERING NUMBER	ITEM CODE	WT. KG.
18	MST Mounting Bracket LH (incl. bushings)	MST-MBL	79436	2.6
19	MST Mounting Bracket RH (incl. bushings)	MST-MBR	79437	2.6
20	MST Drop Brackets (2)	MSTDB	79434	12.6

*Hardware included

Shaded items are made to order. Lead time 3 weeks.

Stock items (non-shaded) refer to (*) for specific lead time, if not specified, standard lead time applies.
 Non-stock items (shaded) please contact Flexco for dispatch options and lead times.

Product Ordering Information

MHS - BT Heavy Duty Secondary Cleaner

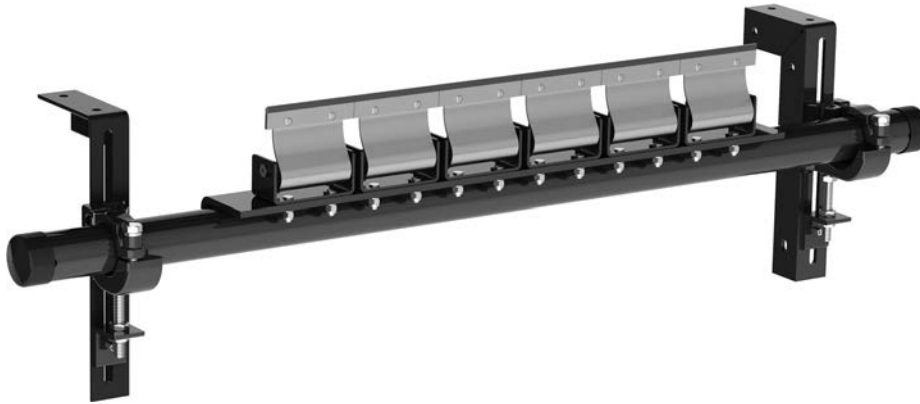

MHS HD with Bolt Tensioner (MHS-BT) Mild Steel

BELT WIDTH mm	ORDERING NUMBER	ITEM CODE	TIP WIDTH mm	POLE LENGTH mm	WT. KG.
600	MHS-600BTV	77481	600	1350	44.4
750	MHS-750BTV	77482	750	1500	49.3
900	MHS-900BTV	77483	900	1650	54.3
1050	MHS-1050BTV	77484	1050	1800	59.2
1200	MHS-1200BTV	77525	1200	1950	64.1
1350	MHS-1350BTV	77485	1350	2100	69.0
1500	MHS-1500BTV	77486	1500	2350	73.9
1800	MHS-1800BTV	77487	1800	2650	83.6
2100	MHS-2100BTV	77488	2100	3200	95.7
2400	MHS-2400BTV	77489	2400	3250	103.2

Lead time: 3 weeks

MHS HD with Bolt Tensioner (MHS-BT) Stainless Steel

BELT WIDTH mm	ORDERING NUMBER	ITEM CODE	TIP WIDTH mm	POLE LENGTH mm	WT. KG.
600	MHS-600BTV-S/S	77490	600	1350	45.3
750	MHS-750BTV-S/S	77491	750	1500	50.3
900	MHS-900BTV-S/S	77492	900	1650	55.3
1050	MHS-1050BTV-S/S	77493	1050	1800	60.4
1200	MHS-1200BTV-S/S	77526	1200	1950	65.4
1350	MHS-1350BTV-S/S	77494	1350	2100	70.4
1500	MHS-1500BTV-S/S	77495	1500	2350	75.4
1800	MHS-1800BTV-S/S	77496	1800	2650	85.3
2100	MHS-2100BTV-S/S	77497	2100	3200	97.6
2400	MHS-2400BTV-S/S	77498	2400	3250	105.3

Lead time: 3 weeks

Stock items (non-shaded) refer to (*) for specific lead time, if not specified, standard lead time applies.

Non-stock items (shaded) please contact Flexco for dispatch options and lead times.

Replacement Parts List

MHS - BT Heavy Duty Secondary Cleaner

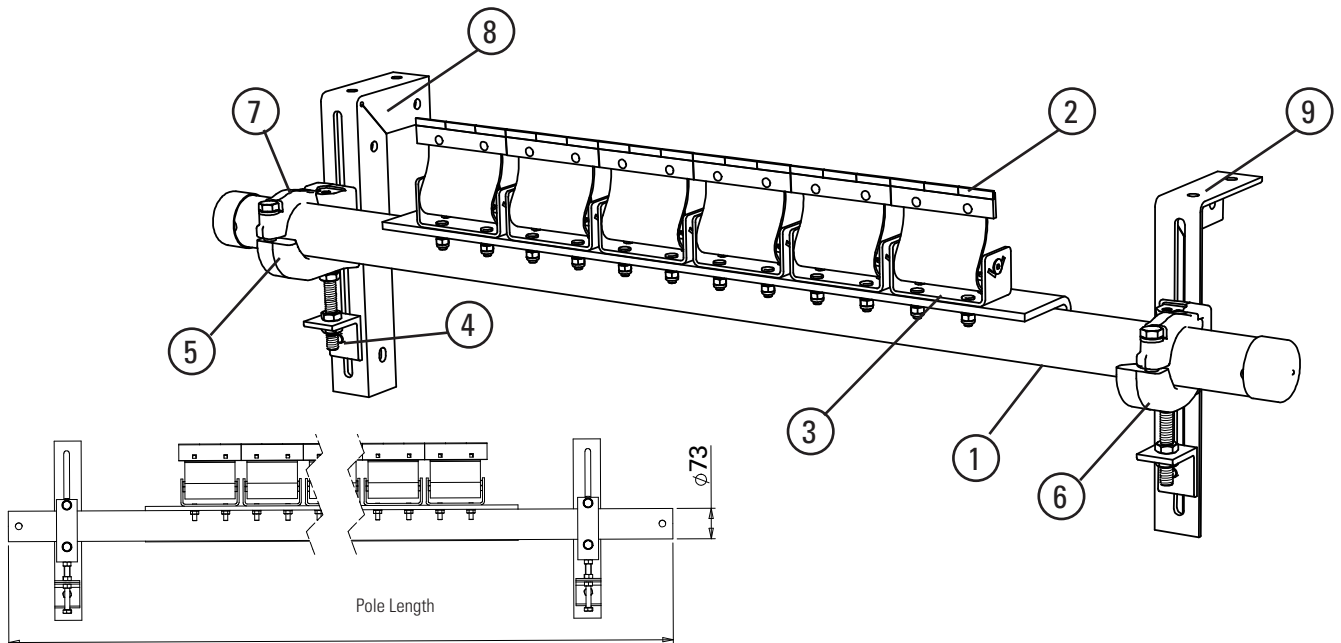

Replacement Parts

REF	DESCRIPTION		MILD STEEL			STAINLESS STEEL		
	BELT WIDTH mm	POLE LENGTH mm	ORDERING NUMBER	ITEM CODE	WT. KG.	ORDERING NUMBER	ITEM CODE	WT. KG.
1	600	1350	MHS-P600*	77499	21.0	MHS-P600S/S*	77508	21.5
	750	1500	MHS-P750*	77500	23.5	MHS-P750S/S*	77509	24.0
	900	1650	MHS-P900*	77501	26.0	MHS-P900S/S*	77510	26.5
	1050	1800	MHS-P1050*	77502	28.5	MHS-P1050S/S*	77511	29.0
	1200	1950	MHS-P1200*	77527	31.0	MHS-P1200S/S*	77528	31.8
	1350	2100	MHS-P1350*	77503	33.5	MHS-P1350S/S*	77512	34.3
	1500	2350	MHS-P1500*	77504	36.0	MHS-P1500S/S*	77513	36.8
	1800	2650	MHS-P1800*	77505	38.5	MHS-P1800S/S*	77514	39.3
	2100	3200	MHS-P2100*	77506	43.5	MHS-P2100S/S*	77515	44.5
	2400	3250	MHS-P2400*	77507	51.0	MHS-P2400S/S*	77516	52.0
2	R - V-Tip (for vulcanised belts only)		RSA150	73628	0.4	RVT6-S/S	76205	0.4
	C-Tip (for mechanically spliced and vulcanised belts)		CT6	74535	0.4			
3	PowerFlex™ Cushion		SPFC	79200	2.0	SPFC-S/S	79201	2.0
4	Adjusting Bracket Kit* (1ea.)		PAB	75513	0.7	PAB-S/S	75515	0.7
5	HD Pole Clamp Kit Left* (1ea.) (incl. item 9a) (for sizes 1200-2400mm)		CCKHDL	79225	4.0	CCKHDL-S/S	79227	4.0
6	HD Pole Clamp Kit Right* (1ea.) (incl. item 9a) (for sizes 1200-2400mm)		CCKHDR	79229	4.0	CCKHDR-S/S	79231	4.0
7	HD Cradle Clamp Top Strap (1ea.) (for use on L or R HD Pole Clamp Kit)		CCKHDTS	79233	0.8	CCKHDTS-S/S	73235	0.8
8	Mounting Bracket Kit Left		PMBL (left)	75516	3.8	PMBL-S/S (left)	75518	3.8
9	Mounting Bracket Kit Right		PMBL (right)	75519	3.8	PMBL-S/S (right)	75521	3.8
-	HD Cradle Clamp Mounting Kit* (for sizes 1200-2400mm) (incl. 2 ea. item 4, and 1 ea. items 5, 6, 8 & 9)		CCMKHD	78920	16.7	CCMKHD-S/S	78922	16.7

*Lead time: 3 weeks

Stock items (non-shaded) refer to (*) for specific lead time, if not specified, standard lead time applies.

Non-stock items (shaded) please contact Flexco for dispatch options and lead times.

Product Ordering Information

MHS - SST Heavy Duty Secondary Cleaner

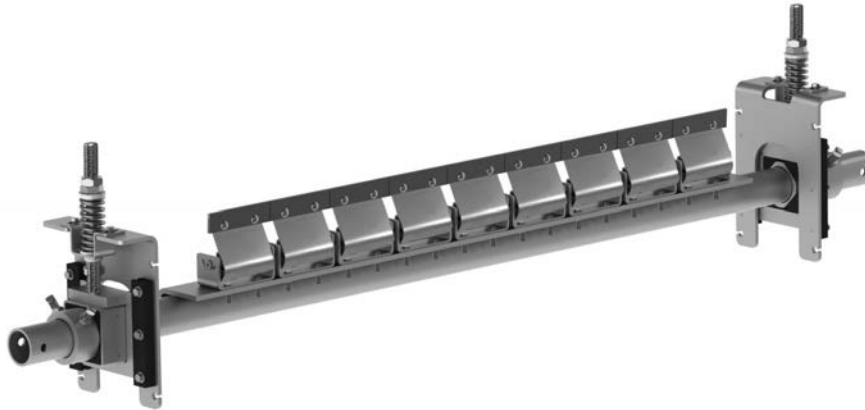

MHS HD with SST Spring Tensioner (Complete MHS-FP Cleaner-V Tips)

BELT WIDTH mm	TIP WIDTH mm	POLE LENGTH mm	MILD STEEL			STAINLESS STEEL		
			ORDERING NUMBER	ITEM CODE	WT. KG.	ORDERING NUMBER	ITEM CODE	WT. KG.
600	600	1350	MHS-600FPV	77789	56.8	MHS-600FPV-S/S	77799	58.0
750	750	1500	MHS-750FPV	77790	61.8	MHS-750FPV-S/S	77800	63.0
900	900	1650	MHS-900FPV	77791	67.0	MHS-900FPV-S/S	77801	68.3
1050	1050	1800	MHS-1050FPV	77792	71.8	MHS-1050FPV-S/S	77802	73.3
1200	1200	1950	MHS-1200FPV	77793	76.8	MHS-1200FPV-S/S	77803	78.3
1350	1350	2100	MHS-1350FPV	77794	81.5	MHS-1350FPV-S/S	77804	83.3
1500	1500	2350	MHS-1500FPV	77795	86.5	MHS-1500FPV-S/S	77805	88.3
1800	1800	2650	MHS-1800FPV	77796	96.5	MHS-1800FPV-S/S	77806	98.5
2100	2100	3200	MHS-2100FPV	77797	108.5	MHS-2100FPV-S/S	77807	110.8
2400	2400	3250	MHS-2400FPV	77798	125.0	MHS-2400FPV-S/S	77808	127.0

Lead time: 3 weeks

Stock items (non-shaded) refer to (*) for specific lead time, if not specified, standard lead time applies.

Non-stock items (shaded) please contact Flexco for dispatch options and lead times.

Replacement Parts List

MHS - SST Heavy Duty Secondary Cleaner

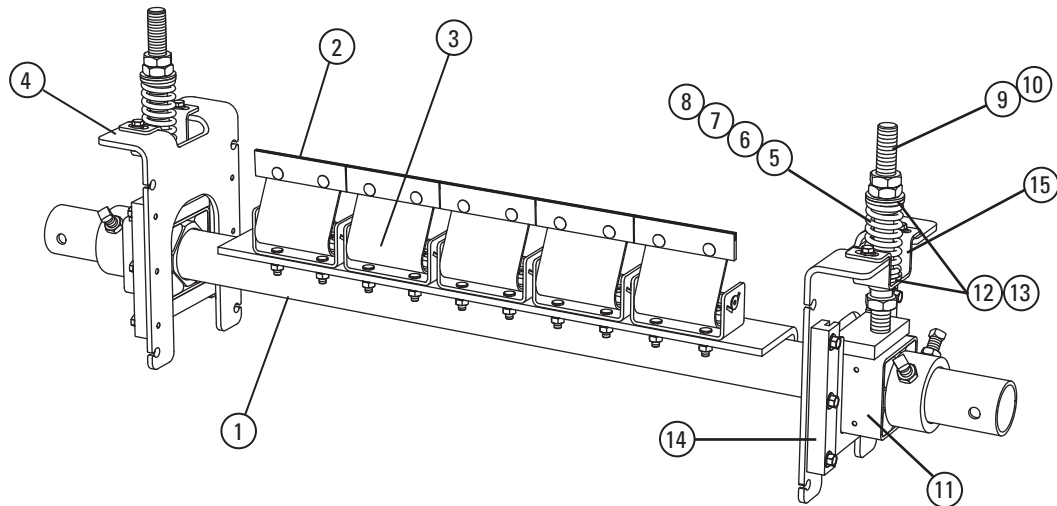

Replacement Parts

REF	DESCRIPTION		MILD STEEL			STAINLESS STEEL		
			ORDERING NUMBER	ITEM CODE	WT. KG.	ORDERING NUMBER	ITEM CODE	WT. KG.
	BELT WIDTH mm	POLE LENGTH mm						
1	600	1350	MHS-P600*	77499	23.5	MHS-P600S/S*	77508	24.0
	750	1500	MHS-P750*	77500	26.0	MHS-P750S/S*	77509	26.5
	900	1650	MHS-P900*	77501	28.5	MHS-P900S/S*	77510	29.0
	1050	1800	MHS-P1050*	77502	31.0	MHS-P1050S/S*	77511	31.7
	1200	1950	MHS-P1200*	77527	33.5	MHS-P1200S/S*	77528	34.3
	1350	2100	MHS-P1350*	77503	36.0	MHS-P1350S/S*	77512	36.8
	1500	2350	MHS-P1500*	77504	38.5	MHS-P1500S/S*	77513	39.3
	1800	2650	MHS-P1800*	77505	43.5	MHS-P1800S/S*	77514	44.4
	2100	3200	MHS-P2100*	77506	51.0	MHS-P2100S/S*	77515	52.0
	2400	3250	MHS-P2400*	77507	58.0	MHS-P2400S/S*	77516	59.3
2	C-Tip (suits mechanical fastened belt)		CT6	74535	.4	N/A	N/A	—
	V-Tip (suits vulcanised belt)		RSA150	73628	.4	RVT6-S/S	76205	.4
3	PowerFlex™ Cushion		SPFC	79200	2.0	SPFC-S/S	79201	2.0
4	SST HD® Mounting Base Kit* (includes 1 mounting base and 2 slide guides)		SSTHDMK	77870	4.6	STHDMK2-S/S	77634	4.6
5	SST Spring - White (1 ea.) for belts 450-750mm		STS-W	75846	0.2	STS-W-S/S	77630	0.2
6	SST Spring - Silver (1 ea.) for belts 900-1500mm		STS-S	75843	0.4	STS-S-S/S	77631	0.4
7	SST Spring - Black (1 ea.) for belts 1800-2100mm		STS-B	75844	0.5	STS-B-S/S	77632	0.5
8	SST Spring - Gold (1 ea.) for belts over 2100mm		STS-G	78142	0.7			
9	SST Adj Rod Kit* (incl. 1 rod, 2 nuts, 2 bushings, 1 washer) for belts 450-1500 mm		STAK	75847	1.3	STAK	75847	1.3
10	SST HD Adj Rod Kit* (incl. 1 rod, 2 nuts, 2 HD bushings, 1 washer) for belts 1800-2100mm		STAKHD	75892	1.4	STAKHD	75892	1.4
11	SST HD Torsion Pole Mount* (1 ea.)		SSTHDPM	77868	6.8	STHDPM2-S/S	77633	6.8
12	SST Bushing Kit - White/Silver		SSTBK-W	76636	0.1	SSTBK-W	76636	0.1
13	SST Bushing Kit - Black/Gold		SSTBK-B	76637	0.1	SSTBK-B	76637	0.1
14	ST Slide Guide Kit		STGK2	77635	0.5	STGK2	77635	0.5
-	SST HD Cartridge Tensioner - White (includes 1 ea. item 5, 9, 12, 14) for belts 450-750 mm		SST1HDM-W	78517	13.7	SST1HDM-W-S/S	78394	13.7
-	SST HD Cartridge Tensioner - Silver (includes 1 ea. item 6, 9, 12, 14) for belts 900-1500 mm		SST1HDM-S	78518	13.9	SST1HDM-S-S/S	78395	13.9
-	SST HD Cartridge Tensioner - Black (includes 1 ea. item 7, 10, 13, 14) for belts 1800-2100 mm		SST1HDM-B	78519	14.1	SST1HDM-B-S/S	78396	14.1
-	SST HD Cartridge Tensioner - Gold (includes 1 ea. item 8, 10, 13, 14) for belts over 2100 mm		SST1HDM-G	79069	14.3			
15	SST Hat Channel Kit		SSTHK	79070	0.7	SSTHK-S/S	79071	0.7

*Lead time: 3 weeks

Stock items (non-shaded) refer to (*) for specific lead time, if not specified, standard lead time applies.

Non-stock items (shaded) please contact Flexco for dispatch options and lead times.

Replacement Parts List

MHS - SST Heavy Duty Secondary Cleaner

ATV Replacement Parts

REF	DESCRIPTION	ORDERING NUMBER	ITEM CODE	WT. KG.
1	Mounting Bracket LH	PMBL-S/S	75518	3.8
2	Mounting Bracket RH	PMBR-S/S	75521	3.8
3	Air Tensioner Slider	ATV-SLIDE	62425	0.2
4	Air Tension Cradle Blocks 60mm Kit	ATV-MOUNT	62424	2.4
5	Air Tension Cradle Blocks 73mm Kit	ATV-MOUNT	63073	2.4
6	Air Tension Adjusting Angle	ATV-ANGLE	62426	1.0
7	Air Bag	ATV-BAG	62036	0.2
8	Hex Nut S/S	HEX NUT	G1211	0.1
9	Air Line Adaptor	ATV-NIP	62037	0.1
10	PAT Control Box 60psi	PACB60	78683	5.0
11	PAT Control Box 100psi	PACB100	79656	5.0
-	Secondary Air Tension 60mm Complete Kit	ATVK-60	62409	13.0
-	Secondary Air Tension 73mm Complete Kit	ATVK-73	63072	15.0

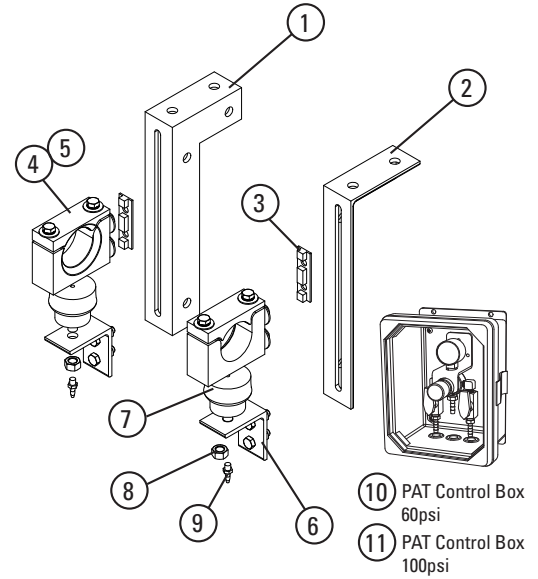

Stock items (non-shaded) refer to (*) for specific lead time, if not specified, standard lead time applies.

Non-stock items (shaded) please contact Flexco for dispatch options and lead times.

Specifications & Guidelines

MHS - SST Heavy Duty Secondary Cleaner

Clearance Guidelines for Installation

HORIZONTAL CLEARANCE REQUIRED mm	VERTICAL CLEARANCE REQUIRED mm
100	238

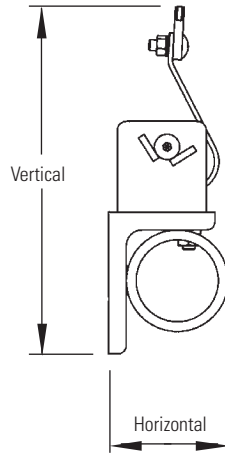

Spring Length Chart for SST Spring Tensioner

BLADE WIDTH mm	WHITE SPRINGS mm	SILVER SPRINGS mm	BLACK SPRINGS mm
450	80	100	N/A
600	70	90	N/A
750	70	90	N/A
900	N/A	90	90
1050	N/A	90	90
1200	N/A	80	90
1350	N/A	80	90
1500	N/A	80	80
1800	N/A	N/A	80
2100	N/A	N/A	70

Shading indicates preferred spring option.

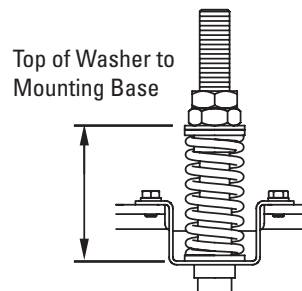

Specifications:

- Maximum Belt SpeedContact Flexco®
- Temperature Rating-35°C to 82°C
- Usable Blade Wear Length.....9 mm
- Blade Materials.....C-Tip: Impact Resistant Tungsten Carbide (works with mechanical fasteners)
V-Tip: Long Life Tungsten Carbide (for vulcanised belts only)

Product Ordering Information

Spring Covers and Tensioner Lock

Spring Covers

ORDERING NUMBER	ITEM CODE	WT. KG.
SPG-CVR-A	77387	0.14
SPG-CVR-B	77388	0.14
SPG-CVR-C	77389	0.14
SPG-CVR-D	77390	0.18
SPG-CVR-E	77391	0.18
SPG-CVR-F	77392	0.14
SPG-CVR-G	77393	0.14
SPG-CVR-H	77741	0.14

Includes 1 spring cover

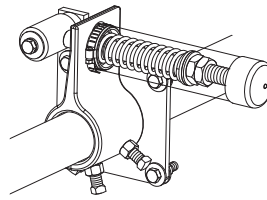
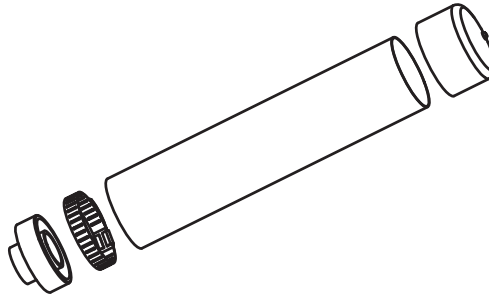

Spring cover on Primary Cleaner tensioner

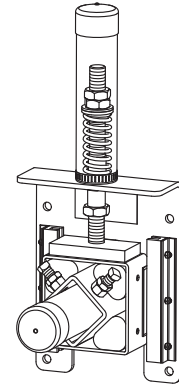

Spring cover on Secondary cleaner tensioner

Tensioner Lock

Designed to prevent tampering or unauthorized retensioning of the cleaner.

ORDERING NUMBER	ITEM CODE	WT. KG.
TEN-LOCK-KIT	77443	0.18

*For MSP, MMP, MHP, MHCP, H-Type® Primary Cleaners and MSS, MHS, MDWS Secondary Cleaners
Includes 1 tensioner lock

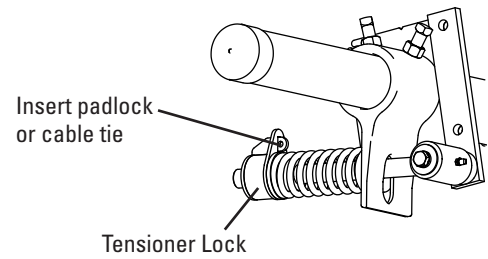
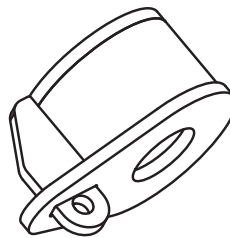

Tensioner Lock

(Primary Cleaner tensioner shown)

Stock items (non-shaded) refer to (*) for specific lead time, if not specified, standard lead time applies.

Non-stock items (shaded) please contact Flexco for dispatch options and lead times.

Patent pending

Product Ordering Information

P-Type® SAC Secondary Cleaner with Service Advantage Cartridge™

P-Type® SAC Secondary with V-Tips*

BELT WIDTH mm	ORDERING NUMBER	ITEM CODE	WT. KG.
600	PV600-SAC	78020	62.3
750	PV750-SAC	78021	68.4
900	PV900-SAC	78022	74.4
1050	PV1050-SAC	78023	80.4
1200	PV1200-SAC	78024	86.4
1350	PV1350-SAC	78025	92.5
1500	PV1500-SAC	78026	98.5
1800	PV1800-SAC	78027	110.6
1500	PV1500-2SAC	78028	137.8
1800	PV1800-2SAC	78029	150.0
2100	PV2100-2SAC	78030	162.5
2400	PV2400-2SAC	78031	174.7
3000	PV3000-2SAC	78032	201.3

*NOTE: V-Tips can be used ONLY on vulcanised belts.

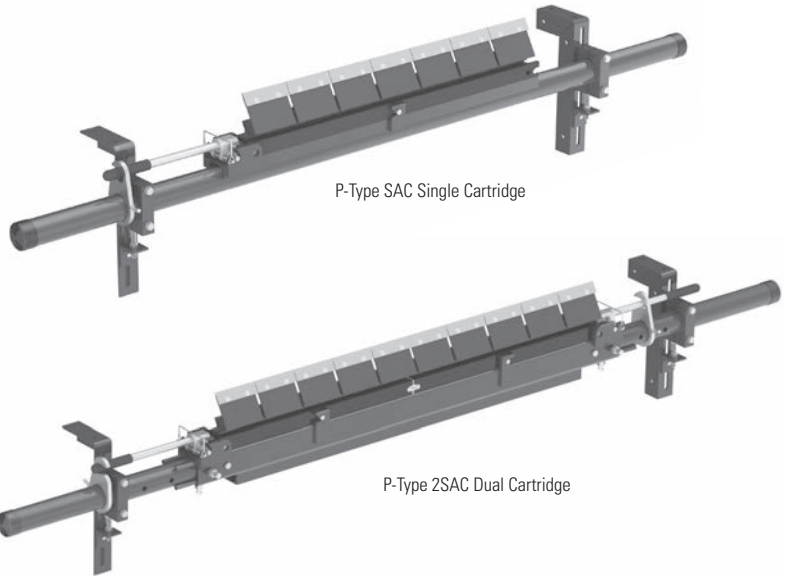

P-Type SAC Stainless Steel Secondary with V-Tips*

BELT WIDTH mm	ORDERING NUMBER	ITEM CODE	WT. KG.
600	PV600-SAC-S/S	78329	62.3
750	PV750-SAC-S/S	78330	68.4
900	PV900-SAC-S/S	78331	74.4
1050	PV1050-SAC-S/S	78332	80.4
1200	PV1200-SAC-S/S	78333	86.4
1350	PV1350-SAC-S/S	78334	92.5
1500	PV1500-SAC-S/S	78335	98.5
1800	PV1800-SAC-S/S	78336	110.6
1500	PV1500-2SAC-S/S	78337	137.8
1800	PV1800-2SAC-S/S	78338	150.0
1950	PV1950-2SAC-S/S	78656	156.2
2100	PV2100-2SAC-S/S	78339	162.5
2400	PV2400-2SAC-S/S	78340	174.7
3000	PV3000-2SAC-S/S	78341	201.3

*NOTE: V-Tips can be used ONLY on vulcanised belts.

Replacement Tips

ORDERING NUMBER	ITEM CODE	WT. KG.
CT6 (C-Tip)	74535	0.4
PSA150 (V-Tip)	73156	0.4

Tips Required Per Cleaner Size

BELT WIDTH mm	BLADE COVERAGE mm	V-TIPS REQUIRED
600	600	4
750	750	5
900	900	6
1050	1050	7
1200	1200	8
1350	1350	9
1500	1500	10
1800	1800	12
2100	2100	14
2400	2400	16
3000	3000	20

Product Notes:

- Patent-pending Service Advantage Cartridge™ allows for easy removal in even the dirtiest conditions.
- Pole Length: Belt width plus 1350 mm (single cartridge cleaners); Belt width plus 1500 mm (dual cartridge cleaners).
- Tips are set at a non-aggressive 70° angle to give quick relief for passing mechanical splices.
- C-Tips are for mechanically fastened or vulcanised belts. V-Tips are for vulcanised belts only.
- Tensioner mounting brackets included for fast and easy installation.
- Cartridge Removal Kit included for easy removal of the cartridge.

Stock items (non-shaded) refer to (*) for specific lead time, if not specified, standard lead time applies.

Non-stock items (shaded) please contact Flexco for dispatch options and lead times.

U.S. Patent Pending

Product Ordering Information

P-Type® SAC
Secondary Cleaner
with Service Advantage Cartridge™

P-Type® SAC Cartridge Kits with V-Tips*

BELT WIDTH mm	ORDERING NUMBER	ITEM CODE	WT. KG.
600	P-CARK-V24/600	78080	11.4
750	P-CARK-V30/750	78081	13.6
900	P-CARK-V36/900	78082	15.7
1050	P-CARK-V42/1050	78083	17.9
1200	P-CARK-V48/1200	78084	20.0
1350	P-CARK-V54/1350	78085	22.2
1500	P-CARK-V60/1500	78086	24.4
1800	P-CARK-V72/1800	78087	28.7
1500	P-CARK2-V60/1500	78093	39.7
1800	P-CARK2-V72/1800	78094	46.4
2100	P-CARK2-V84/2100	78095	53.2
2400	P-CARK2-V96/2400	78096	59.9
3000	P-CARK2-V120/3000	78097	73.6

*NOTE: V-Tips can be used ONLY on vulcanised belts.

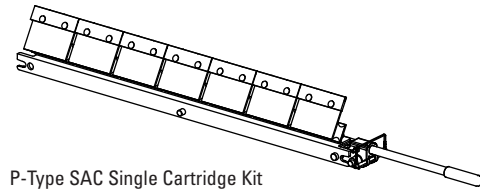

P-Type SAC Single Cartridge Kit

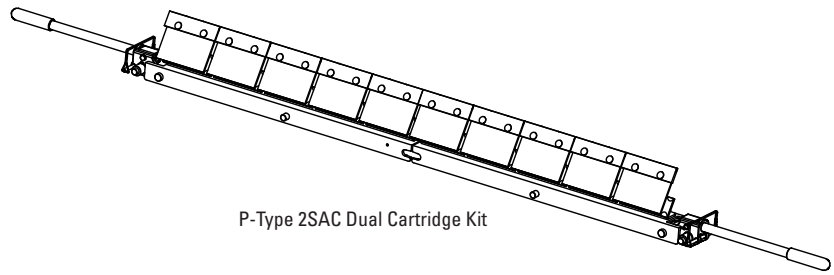

P-Type 2SAC Dual Cartridge Kit

P-Type SAC Stainless Steel Cartridge Kits with V-Tips*

BELT WIDTH mm	ORDERING NUMBER	ITEM CODE	WT. KG.
600	P-CARK-V24/600-S/S PVECKSS	82815	11.4
750	P-CARK-V30/750-S/S PVECKSS	82816	13.6
900	P-CARK-V36/900-S/S PVECKSS	82817	15.7
1050	P-CARK-V42/1050-S/S PVECKSS	82818	17.9
1200	P-CARK-V48/1200-S/S PVECKSS	82819	20.0
1350	P-CARK-V54/1350-S/S PVECKSS	82820	22.2
1500	P-CARK-V60/1500-S/S PVECKSS	82821	24.4
1800	P-CARK-V72/1800-S/S PVECKSS	82822	28.7
1500	P-CARK2-V60/1500-S/S PV2ECKSS	82823	39.7
1800	P-CARK2-V72/1800-S/S PV2ECKSS	82824	46.4
2000	P-CARK2-V78/1950-S/S PV2ECKSS	82876	49.2
2100	P-CARK2-V84/2100-S/S PV2ECKSS	82825	53.2
2400	P-CARK2-V96/2400-S/S PV2ECKSS	82826	59.9
3000	P-CARK2-V120/3000-S/S PV2ECKSS	82827	73.6

*NOTE: V-Tips can be used ONLY on vulcanised belts.

Stock items (non-shaded) refer to (*) for specific lead time, if not specified, standard lead time applies.

Non-stock items (shaded) please contact Flexco for dispatch options and lead times.

Replacement Parts List

P-Type® SAC (Mild Steel) Secondary Cleaner with Service Advantage Cartridge™

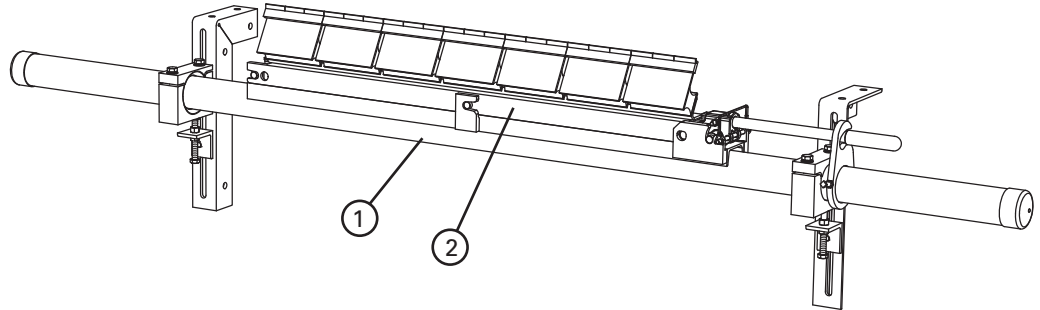

Replacement Parts

REF	DESCRIPTION	ORDERING NUMBER	ITEM CODE	WT. KG.
1	SAC Cartridge Pole 600 mm	SACPL-24/600	77887	29.7
	SAC Cartridge Pole 750 mm	SACPL-30/750	77888	32.3
	SAC Cartridge Pole 900 mm	SACPL-36/900	77889	35.0
	SAC Cartridge Pole 1050 mm	SACPL-42/1050	77890	37.6
	SAC Cartridge Pole 1200 mm	SACPL-48/1200	77891	40.3
	SAC Cartridge Pole 1350 mm	SACPL-54/1350	77892	42.9
	SAC Cartridge Pole 1500 mm	SACPL-60/1500	77893	45.6
	SAC Cartridge Pole 1800 mm	SACPL-72/1800	77894	50.9
	SAC Cartridge Center Pole 1500 mm (Dual)	SACPL2-60/1500	77895	35.1
	SAC Cartridge Center Pole 1800 mm (Dual)	SACPL2-72/1800	77896	40.6
	SAC Cartridge Center Pole 2100 mm (Dual)	SACPL2-84/2100	77897	46.2
	SAC Cartridge Center Pole 2400 mm (Dual)	SACPL2-96/2400	77898	51.8
	SAC Cartridge Center Pole 3000 mm (Dual)	SACPL2-120/3000	77899	64.5
1a	Extender Pole (for use with Dual Cartridge Center Pole)	MHP-EP	76392	24.5
2	SAC Repl Cartridge S/S 600 mm	CART-24/600-S/S	78576	4.5
	SAC Repl Cartridge S/S 750 mm	CART-30/750-S/S	78577	5.6
	SAC Repl Cartridge S/S 900 mm	CART-36/900-S/S	78578	6.7
	SAC Repl Cartridge S/S 1050 mm	CART-42/1050-S/S	78579	7.8
	SAC Repl Cartridge S/S 1200 mm	CART-48/1200-S/S	78580	8.9
	SAC Repl Cartridge S/S 1350 mm	CART-54/1350-S/S	78581	10.0
	SAC Repl Cartridge S/S 1500 mm	CART-60/1500-S/S	78582	11.3
	SAC Repl Cartridge S/S 1800 mm	CART-72/1800-S/S	78583	13.5
	SAC Repl Cartridge S/S 1500 mm (Dual)	CART2-60/1500-S/S	78584	11.2
	SAC Repl Cartridge S/S 1800 mm (Dual)	CART2-72/1800-S/S	78585	13.4
	SAC Repl Cartridge S/S 1950 mm (Dual)	CART2-78/1950-S/S	78635	14.5
	SAC Repl Cartridge S/S 2100 mm (Dual)	CART2-84/2100-S/S	78586	15.6
	SAC Repl Cartridge S/S 2400 mm (Dual)	CART2-96/2400-S/S	78587	17.8
	SAC Repl Cartridge S/S 3000 mm (Dual)	CART2-120/3000-S/S	78588	22.6

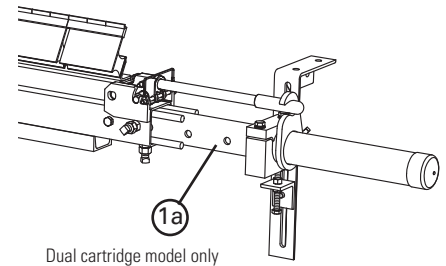

Stock items (non-shaded) refer to (*) for specific lead time, if not specified, standard lead time applies.

Non-stock items (shaded) please contact Flexco for dispatch options and lead times.

Replacement Parts List

P-Type® SAC (Mild Steel) Secondary Cleaner with Service Advantage Cartridge™

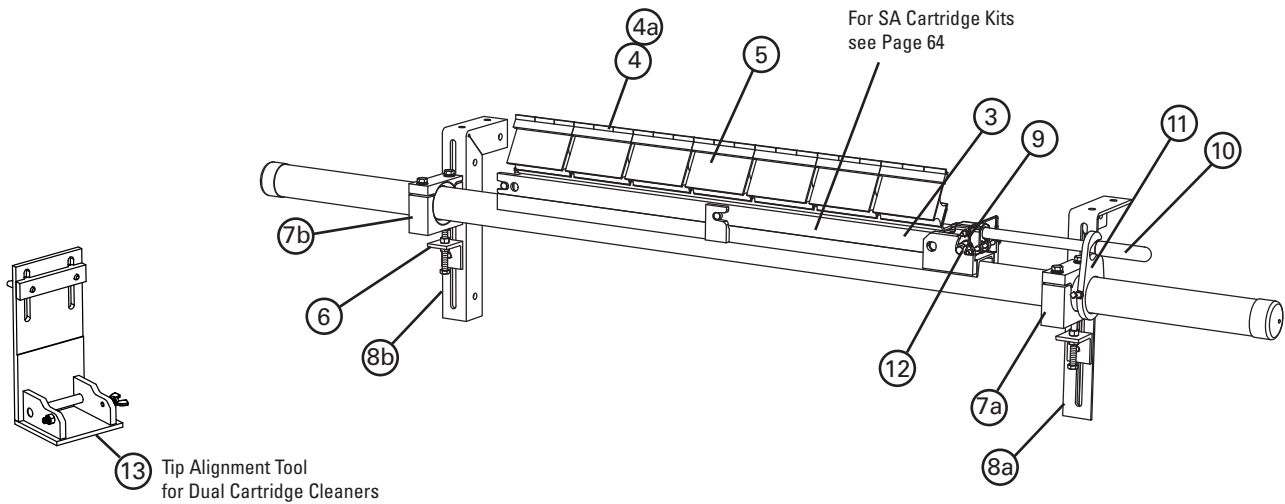

Replacement Parts (Continued)

REF	DESCRIPTION	ORDERING NUMBER	ITEM CODE	WT. KG.
3	SAC Cartridge P-Type® Adapter Plate 600 mm	PCAP-24/600	77913	2.1
	SAC Cartridge P-Type Adapter Plate 750 mm §	PCAP-30/750	77914	2.8
	SAC Cartridge P-Type Adapter Plate 900 mm §	PCAP-36/900	77915	3.3
	SAC Cartridge P-Type Adapter Plate 1050 mm §	PCAP-42/1050	77916	3.9
	SAC Cartridge P-Type Adapter Plate 1200 mm §	PCAP-48/1200	77917	4.4
	SAC Cartridge P-Type Adapter Plate 1350 mm	PCAP-54/1350	77918	5.0
	SAC Cartridge P-Type Adapter Plate 1500 mm §	PCAP-60/1500	77919	5.6
	SAC Cartridge P-Type Adapter Plate 1800 mm	PCAP-72/1800	77920	6.7
4	C-Tip*	CT6	74535	0.4
4a	P V-Tip* (for vulcanised belts only)	PSA150	73156	0.4
5	Cushion*	PHA	73626	1.6
6	P/R Adjusting Bracket	PAB	75513	0.4
7a	Cradle Clamp Block RH	SMR-CCB-R73	A2843	1.2
7b	Cradle Clamp Block LH	SMR-CCB-L73	A2842	1.2
8a	Mounting Bracket Kit, RH	PMBR	75519	3.8
8b	Mounting Bracket Kit, LH	PMBL	75516	3.8
9	SAC Removal Knuckle	SACRKN	77882	1.5
10	SAC Removal Handle	SACRH	77883	1.4
11	SAC Handle Lock Plate	SACRHL	77884	0.8
12	Knuckle Retainer Pin	SACKRP	77885	0.1
-	SAC Removal Kit (includes 1 ea. items 9,10,11,12)	SACRKT	77886	4.1
13	SAC Cartridge Tip Alignment Tool (Dual)	SAC2-TIP-TL	77866	1.1
-	Cradle Clamp Heavy-Duty Mounting Kit (incl. 2 ea. item 6; incl. 1 ea. items 7a, 7b, 8a, 8b)	CRHMK	62400	10.8

§ If using a dual cartridge, please take the cleaner size and divide by two. That dimension is the size of the brackets needed for conversion to a P-Type cleaner.

Stock items (non-shaded) refer to (*) for specific lead time, if not specified, standard lead time applies.

Non-stock items (shaded) please contact Flexco for dispatch options and lead times.

Replacement Parts List

P-Type[®] SAC (Stainless Steel) Secondary Cleaner with Service Advantage Cartridge™

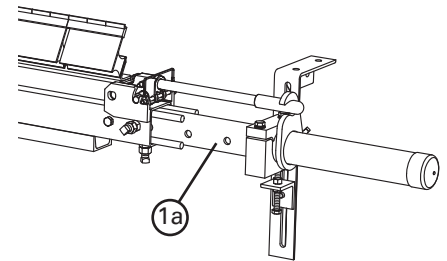
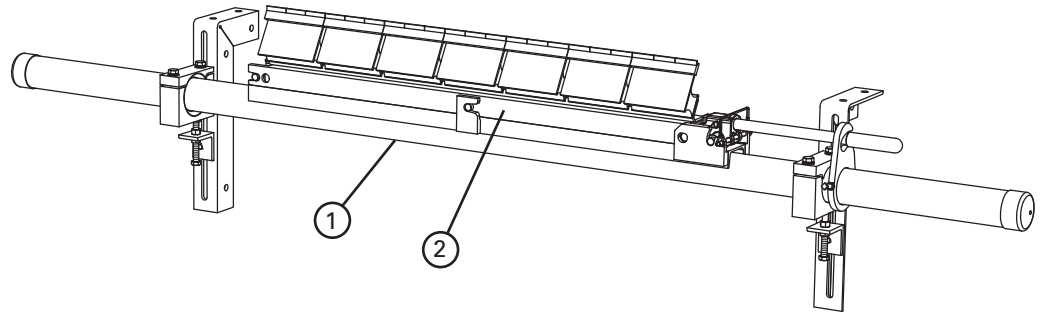

Dual cartridge model only

Replacement Parts

REF	DESCRIPTION	ORDERING NUMBER	ITEM CODE	WT. KG.
1	SAC S/S Cartridge Pole 600 mm	SACPL-24/600-S/S	78371	29.7
	SAC S/S Cartridge Pole 750 mm	SACPL-30/750-S/S	78372	32.3
	SAC S/S Cartridge Pole 900 mm	SACPL-36/900-S/S	78373	35.0
	SAC S/S Cartridge Pole 1050 mm	SACPL-42/1050-S/S	78374	37.6
	SAC S/S Cartridge Pole 1200 mm	SACPL-48/1200-S/S	78375	40.3
	SAC S/S Cartridge Pole 1350 mm	SACPL-54/1350-S/S	78376	42.9
	SAC S/S Cartridge Pole 1500 mm	SACPL-60/1500-S/S	78377	45.6
	SAC S/S Cartridge Pole 1800 mm	SACPL-72/1800-S/S	78378	50.9
	SAC S/S Cartridge Center Pole 1500 mm (Dual)	SACPL2-60/1500-S/S	78379	35.1
	SAC S/S Cartridge Center Pole 1800 mm (Dual)	SACPL2-72/1800-S/S	78380	40.6
	SAC S/S Cartridge Center Pole 1950 mm (Dual)	SACPL2-78/1950-S/S	78642	43.9
	SAC S/S Cartridge Center Pole 2100 mm (Dual)	SACPL2-84/2100-S/S	78381	46.2
	SAC S/S Cartridge Center Pole 2400 mm (Dual)	SACPL2-96/2400-S/S	78382	51.8
	SAC S/S Cartridge Center Pole 3000 mm (Dual)	SACPL2-120/3000-S/S	78383	64.5
1a	S/S Extender Pole (for use with S/S Dual Cartridge Center Pole)	MHP-EP-S/S	77599	24.5
2	SAC Repl Cartridge S/S 600 mm	CART-24/600-S/S	78576	4.5
	SAC Repl Cartridge S/S 750 mm	CART-30/750-S/S	78577	5.6
	SAC Repl Cartridge S/S 900 mm	CART-36/900-S/S	78578	6.7
	SAC Repl Cartridge S/S 1050 mm	CART-42/1050-S/S	78579	7.8
	SAC Repl Cartridge S/S 1200 mm	CART-48/1200-S/S	78580	8.9
	SAC Repl Cartridge S/S 1350 mm	CART-54/1350-S/S	78581	10.0
	SAC Repl Cartridge S/S 1500 mm	CART-60/1500-S/S	78582	11.3
	SAC Repl Cartridge S/S 1800 mm	CART-72/1800-S/S	78583	13.5
	SAC Repl Cartridge S/S 1500 mm (Dual)	CART2-60/1500-S/S	78584	11.2
	SAC Repl Cartridge S/S 1800 mm (Dual)	CART2-72/1800-S/S	78585	13.4
	SAC Repl Cartridge S/S 1950 mm (Dual)	CART2-78/1950-S/S	78635	14.5
	SAC Repl Cartridge S/S 2100 mm (Dual)	CART2-84/2100-S/S	78586	15.6
	SAC Repl Cartridge S/S 2400 mm (Dual)	CART2-96/2400-S/S	78587	17.8
	SAC Repl Cartridge S/S 3000 mm (Dual)	CART2-120/3000-S/S	78588	22.6

Stock items (non-shaded) refer to (*) for specific lead time, if not specified, standard lead time applies.

Non-stock items (shaded) please contact Flexco for dispatch options and lead times.

Replacement Parts List

P-Type® SAC (Stainless Steel) Secondary Cleaner with Service Advantage Cartridge™

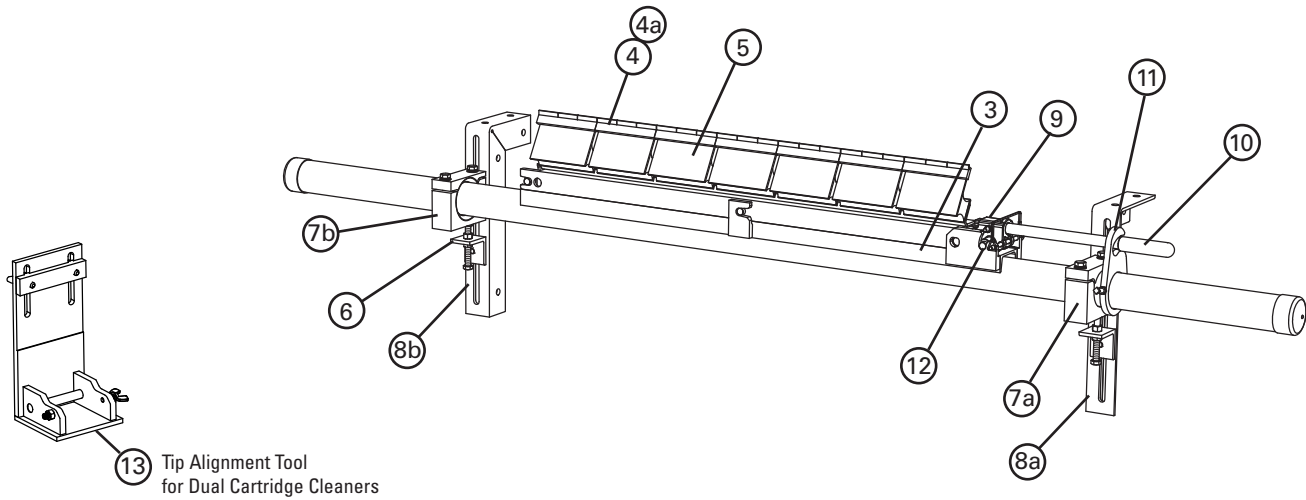

Replacement Parts (Continued)

REF	DESCRIPTION	ORDERING NUMBER	ITEM CODE	WT. KG.
3	SAC Cartridge P-Type® S/S Adapter Plate 600 mm	PCAP-24/600-S/S	78355	2.1
	SAC Cartridge P-Type S/S Adapter Plate 750 mm ‡	PCAP-30/750-S/S	78356	2.8
	SAC Cartridge P-Type S/S Adapter Plate 900 mm ‡	PCAP-36/900-S/S	78357	3.3
	SAC Cartridge P-Type S/S Adapter Plate 1050 mm ‡	PCAP-42/1050-S/S	78358	3.9
	SAC Cartridge P-Type S/S Adapter Plate 1200 mm ‡	PCAP-48/1200-S/S	78359	4.4
	SAC Cartridge P-Type S/S Adapter Plate 1350 mm	PCAP-54/1350-S/S	78360	5.0
	SAC Cartridge P-Type S/S Adapter Plate 1500 mm ‡	PCAP-60/1500-S/S	78361	5.6
	SAC Cartridge P-Type S/S Adapter Plate 1800 mm	PCAP-72/1800-S/S	78362	6.7
4	C-Tip	CT6	74535	0.4
4a	S/S P V-Tip	PVT6-S/S	75420	0.4
5	S/S P Cushion*	PHSC-S/S	73433	1.6
6	P/R Adjusting Bracket S/S	PAB-S/S	75515	0.4
7a	Cradle Clamp Block RH S/S	CRDLBLK-RH-S/S	A2825	1.2
7b	Cradle Clamp Block LH S/S	CRDLBLK-LH-S/S	A2826	1.2
8a	Mounting Bracket Kit RH S/S	PMBR-S/S	75521	3.8
8b	Mounting Bracket Kit LH S/S	PMBL-S/S	75518	3.8
9	SAC Removal Knuckle	SACRKN	77882	1.5
10	SAC Removal Handle S/S	SACRH-S/S	78397	1.4
11	SAC Handle Lock Plate S/S	SACRHL-S/S	78398	0.8
12	Knuckle Retainer Pin S/S	SACKRP-S/S	78399	0.1
-	SAC Removal Kit S/S (includes 1 ea. items 9,10,11,12)	SACRKT-S/S	78401	4.1
13	SAC Cartridge Tip Alignment Tool (Dual)	SAC2-TIP-TL	77866	1.1
-	Cradle Clamp Stainless Steel Heavy-Duty Mounting Kit (incl. 2 ea. item 6; incl. 1 ea. items 7a, 7b, 8a, 8b)	CRHMK-S/S	62095	10.8

‡ If using a dual cartridge, please take the cleaner size and divide by two. That dimension is the size of the brackets needed for conversion to a P-Type cleaner.

Stock items (non-shaded) refer to (*) for specific lead time, if not specified, standard lead time applies.

Non-stock items (shaded) please contact Flexco for dispatch options and lead times.

Specifications & Guidelines

P-Type® SAC Secondary Cleaner with Service Advantage Cartridge™

Pole Length Specifications*

VERSION	CLEANER SIZE mm	BLADE WIDTH mm	POLE LENGTH mm	MAXIMUM CONVEYOR SPAN mm
Single	600	600	1950	1650
	750	750	2100	1800
	900	900	2250	1950
	1050	1050	2400	2100
	1200	1200	2550	2250
	1350	1350	2700	2400
	1500	1500	2850	2550
Dual	1500	1500	3000	2700
	1800	1800	3300	3000
	2100	2100	3600	3300
	2400	2400	3900	3600
	3000	3000	4500	4200

*For special extra long pole length requirements a Pole Extender Kit (#76024) is available that provides 750 mm of extended pole length.
Pole Diameter - 73 mm

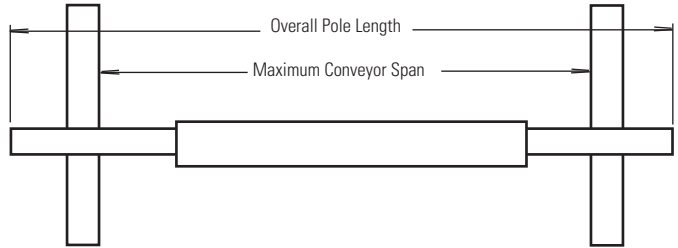

Clearance Guidelines for Installation

VERSION	HORIZONTAL CLEARANCE REQUIRED mm	VERTICAL CLEARANCE REQUIRED mm
Single	114	267
Dual	114	311

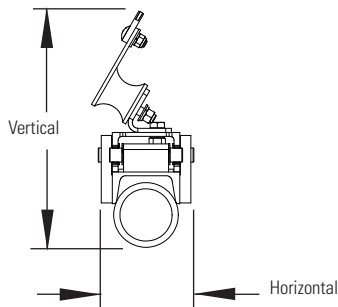

Specifications:

- Maximum Belt Speed5M/sec
- Temperature Rating-35°C to 82°C
- Usable Blade Wear Length.....9 mm
- Blade MaterialsC-Tip: Impact Resistant Tungsten Carbide (works with mechanical fasteners)
V-Tip: Long Life Tungsten Carbide (for vulcanised belts only)
- Available for Belt Widths600 to 3000 mm. Other sizes available upon request.

U.S. Patent Pending

Product Ordering Information

R-Type® SAC Secondary Cleaner with Service Advantage Cartridge™

R-Type® SAC Secondary with V-Tips*

BELT WIDTH mm	ORDERING NUMBER	ITEM CODE	WT. KG.
600	RV600-SAC	78033	58.3
750	RV750-SAC	78034	63.3
900	RV900-SAC	78035	68.3
1050	RV1050-SAC	78036	73.3
1200	RV1200-SAC	78037	78.3
1350	RV1350-SAC	78038	83.3
1500	RV1500-SAC	78039	88.4
1800	RV1800-SAC	78040	98.3
1500	RV1500-2SAC	78041	107.5
1800	RV1800-2SAC	78042	117.7
2100	RV2100-2SAC	78043	127.8
2400	RV2400-2SAC	78044	138.0
3000	RV3000-2SAC	78045	160.6

*NOTE: V-Tips can be used ONLY on vulcanised belts.

R-Type SAC Stainless Steel Secondary with V-Tips*

BELT WIDTH mm	ORDERING NUMBER	ITEM CODE	WT. KG.
600	RV600-SAC-S/S	78342	58.3
750	RV750-SAC-S/S	78343	63.3
900	RV900-SAC-S/S	78344	68.3
1050	RV1050-SAC-S/S	78345	73.3
1200	RV1200-SAC-S/S	78346	78.3
1350	RV1350-SAC-S/S	78347	83.3
1500	RV1500-SAC-S/S	78348	88.4
1800	RV1800-SAC-S/S	78349	98.3
1500	RV1500-2SAC-S/S	78350	107.5
1800	RV1800-2SAC-S/S	78351	117.7
1950	RV1950-2SAC-S/S	78663	122.7
2100	RV2100-2SAC-S/S	78352	127.8
2400	RV2400-2SAC-S/S	78353	138.0
3000	RV3000-2SAC-S/S	78354	160.6

*NOTE: V-Tips can be used ONLY on vulcanised belts.

Product Notes:

- Patent-pending Service Advantage Cartridge™ allows for easy removal in even the dirtiest conditions.
- Pole Length: Belt width plus 1350mm (single cartridge cleaners); Belt width plus 1500mm (dual cartridge cleaners).
- Two-way cushions allow cleaning in both directions.
- C-Tips are for mechanically fastened or vulcanised belts. V-Tips are for vulcanised belts only.
- Tensioner mounting brackets included for fast and easy installation.
- Cartridge Removal Kit included for easy removal of the cartridge.

U.S. Patent Pending

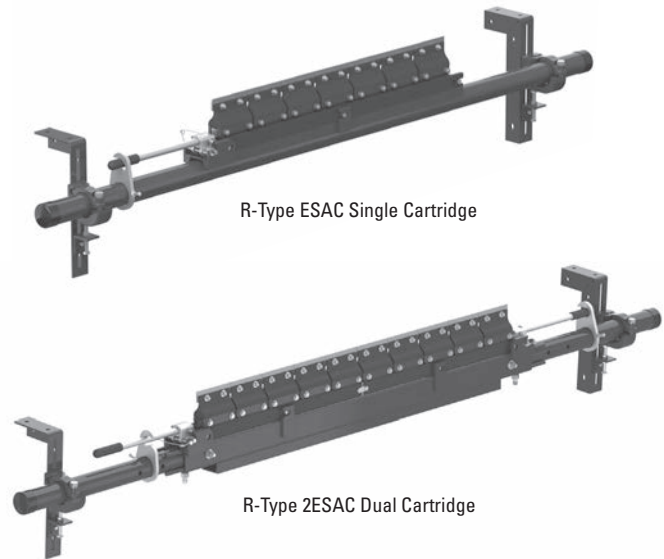

R-Type ESAC Single Cartridge

R-Type 2ESAC Dual Cartridge

Replacement Tips

ORDERING NUMBER	ITEM CODE	WT. KG.
CT6 (C-Tip)	74535	0.4
RSA150 (V-Tip)	73628	0.4

Tips Required Per Cleaner Size

BELT WIDTH mm	BLADE COVERAGE mm	V-TIPS REQUIRED
600	600	4
750	750	5
900	900	6
1050	1050	7
1200	1200	8
1350	1350	9
1500	1500	10
1800	1800	12
2100	2100	14
2400	2400	16
3000	3000	20

Stock items (non-shaded) refer to (*) for specific lead time, if not specified, standard lead time applies.

Non-stock items (shaded) please contact Flexco for dispatch options and lead times.

Product Ordering Information

R-Type® SAC
Secondary Cleaner
with Service Advantage Cartridge™

R-Type® SAC Cartridge Kits with V-Tips*

BELT WIDTH mm	ORDERING NUMBER	ITEM CODE	WT. KG.
600	R-CARK-V24/600	78106	12.3
750	R-CARK-V30/750	78107	14.7
900	R-CARK-V36/900	78108	16.5
1050	R-CARK-V42/1050	78109	19.3
1200	R-CARK-V48/1200	78110	21.6
1350	R-CARK-V54/1350	78111	24.0
1500	R-CARK-V60/1500	78112	26.4
1800	R-CARK-V72/1800	78113	31.1
1500	R-CARK2-V60/1500	78119	31.6
1800	R-CARK2-V72/1800	78120	33.9
2100	R-CARK2-V84/2100	78121	38.6
2400	R-CARK2-V96/2400	78122	43.3
3000	R-CARK2-V120/3000	78123	52.8

*NOTE: V-Tips can be used ONLY on vulcanised belts.

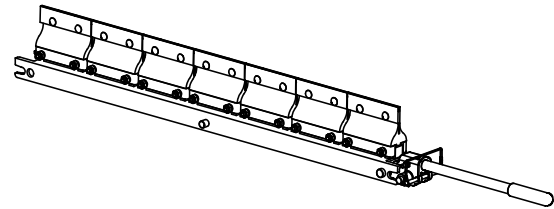

R-Type SAC Single Cartridge Kit

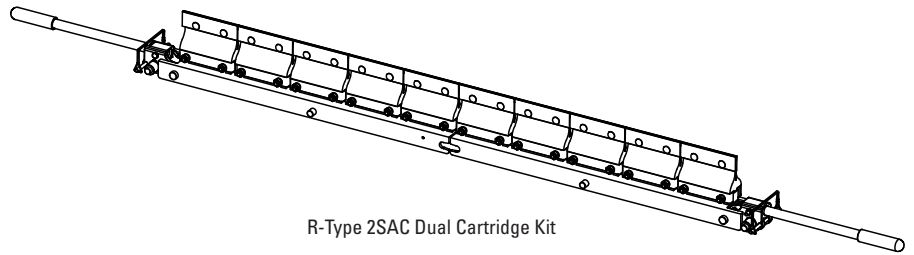

R-Type 2SAC Dual Cartridge Kit

R-Type SAC Stainless Steel Cartridge Kits with V-Tips*

BELT WIDTH mm	ORDERING NUMBER	ITEM CODE	WT. KG.
600	R-CARK-V24/600-S/S RVECKSS	82828	12.3
750	R-CARK-V30/750-S/S RVECKSS	82829	14.7
900	R-CARK-V36/900-S/S RVECKSS	82830	16.5
1050	R-CARK-V42/1050-S/S RVECKSS	82831	19.3
1200	R-CARK-V48/1200-S/S RVECKSS	82832	21.6
1350	R-CARK-V54/1350-S/S RVECKSS	82833	24.0
1500	R-CARK-V60/1500-S/S RVECKSS	82834	26.4
1800	R-CARK-V72/1800-S/S RVECKSS	82835	31.1
1500	R-CARK2-V60/1500-S/S RV2ECKSS	82836	31.6
1800	R-CARK2-V72/1800-S/S RV2ECKSS	82837	33.9
2100	R-CARK2-V84/2100-S/S RV2ECKSS	82838	38.6
2400	R-CARK2-V96/2400-S/S RV2ECKSS	82839	43.3
3000	R-CARK2-V120/3000-S/S RV2ECKSS	82840	52.8

*NOTE: V-Tips can be used ONLY on vulcanised belts.

Stock items (non-shaded) refer to (*) for specific lead time, if not specified, standard lead time applies.

Non-stock items (shaded) please contact Flexco for dispatch options and lead times.

Replacement Parts List

R-Type® SAC (Mild Steel) Secondary Cleaner with Service Advantage Cartridge™

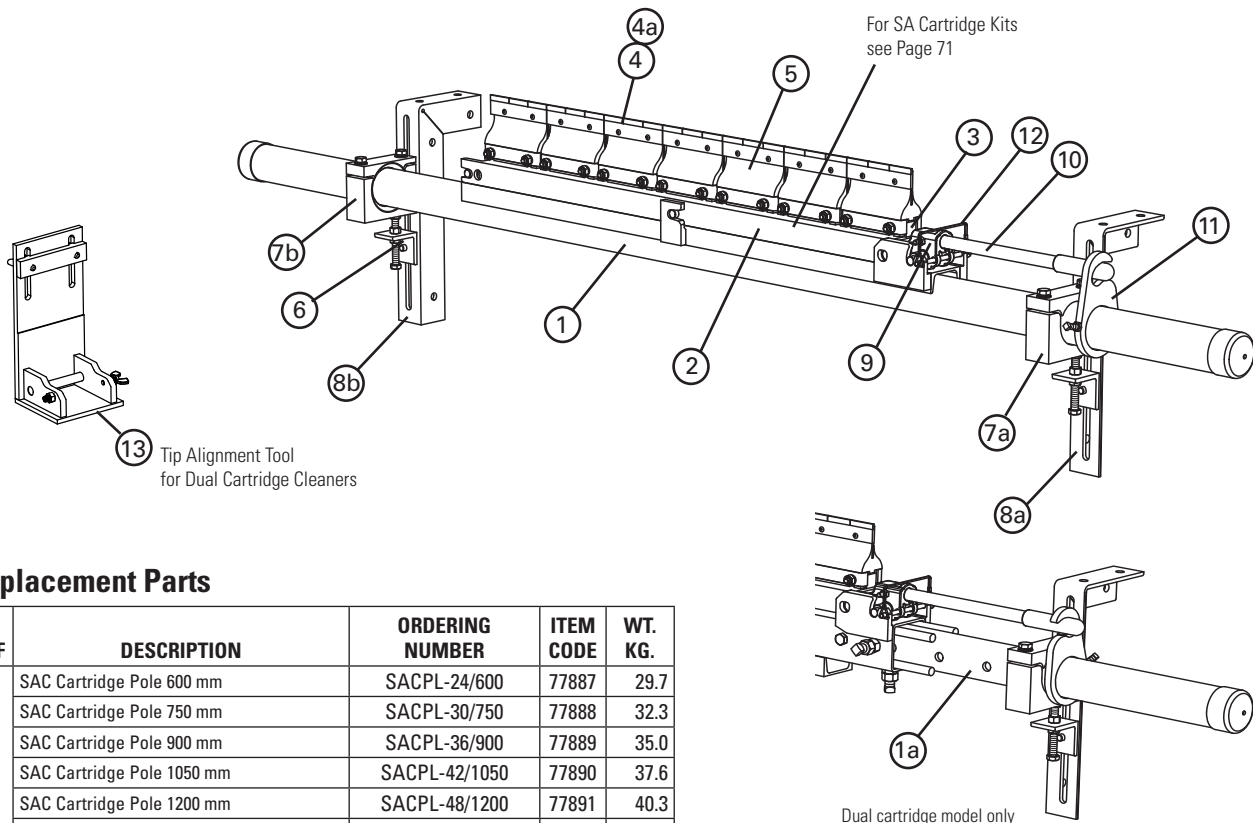

Replacement Parts

REF	DESCRIPTION	ORDERING NUMBER	ITEM CODE	WT. KG.
1	SAC Cartridge Pole 600 mm	SACPL-24/600	77887	29.7
	SAC Cartridge Pole 750 mm	SACPL-30/750	77888	32.3
	SAC Cartridge Pole 900 mm	SACPL-36/900	77889	35.0
	SAC Cartridge Pole 1050 mm	SACPL-42/1050	77890	37.6
	SAC Cartridge Pole 1200 mm	SACPL-48/1200	77891	40.3
	SAC Cartridge Pole 1350 mm	SACPL-54/1350	77892	42.9
	SAC Cartridge Pole 1500 mm	SACPL-60/1500	77893	45.6
	SAC Cartridge Pole 1800 mm	SACPL-72/1800	77894	50.9
	SAC Cartridge Center Pole 1500 mm (Dual)	SACPL2-60/1500	77895	35.1
	SAC Cartridge Center Pole 1800 mm (Dual)	SACPL2-72/1800	77896	40.6
	SAC Cartridge Center Pole 2100 mm (Dual)	SACPL2-84/2100	77897	46.2
	SAC Cartridge Center Pole 2400 mm (Dual)	SACPL2-96/2400	77898	51.8
	SAC Cartridge Center Pole 3000 mm (Dual)	SACPL2-120/3000	77899	64.5
1a	Extender Pole (for use with Dual Cartridge Center Pole)	MHP-EP	76392	24.5
2	SAC Repl Cartridge S/S 600 mm	CART-24/600-S/S	78576	4.5
	SAC Repl Cartridge S/S 750 mm	CART-30/750-S/S	78577	5.6
	SAC Repl Cartridge S/S 900 mm	CART-36/900-S/S	78578	6.7
	SAC Repl Cartridge S/S 1050 mm	CART-42/1050-S/S	78579	7.8
	SAC Repl Cartridge S/S 1200 mm	CART-48/1200-S/S	78580	8.9
	SAC Repl Cartridge S/S 1350 mm	CART-54/1350-S/S	78581	10.0
	SAC Repl Cartridge S/S 1500 mm	CART-60/1500-S/S	78582	11.3
	SAC Repl Cartridge S/S 1800 mm	CART-72/1800-S/S	78583	13.5
	SAC Repl Cartridge S/S 1500 mm (Dual)	CART2-60/1500-S/S	78584	11.2
	SAC Repl Cartridge S/S 1800 mm (Dual)	CART2-72/1800-S/S	78585	13.4
	SAC Repl Cartridge S/S 1950 mm (Dual)	CART2-78/1950-S/S	78635	14.5
	SAC Repl Cartridge S/S 2100 mm (Dual)	CART2-84/2100-S/S	78586	15.6
	SAC Repl Cartridge S/S 2400 mm (Dual)	CART2-96/2400-S/S	78587	17.8
	SAC Repl Cartridge S/S 3000 mm (Dual)	CART2-120/3000-S/S	78588	22.6

Stock items (non-shaded) refer to (*) for specific lead time, if not specified, standard lead time applies.

Non-stock items (shaded) please contact Flexco for dispatch options and lead times.

Replacement Parts List

R-Type® SAC (Mild Steel) Secondary Cleaner with Service Advantage Cartridge™

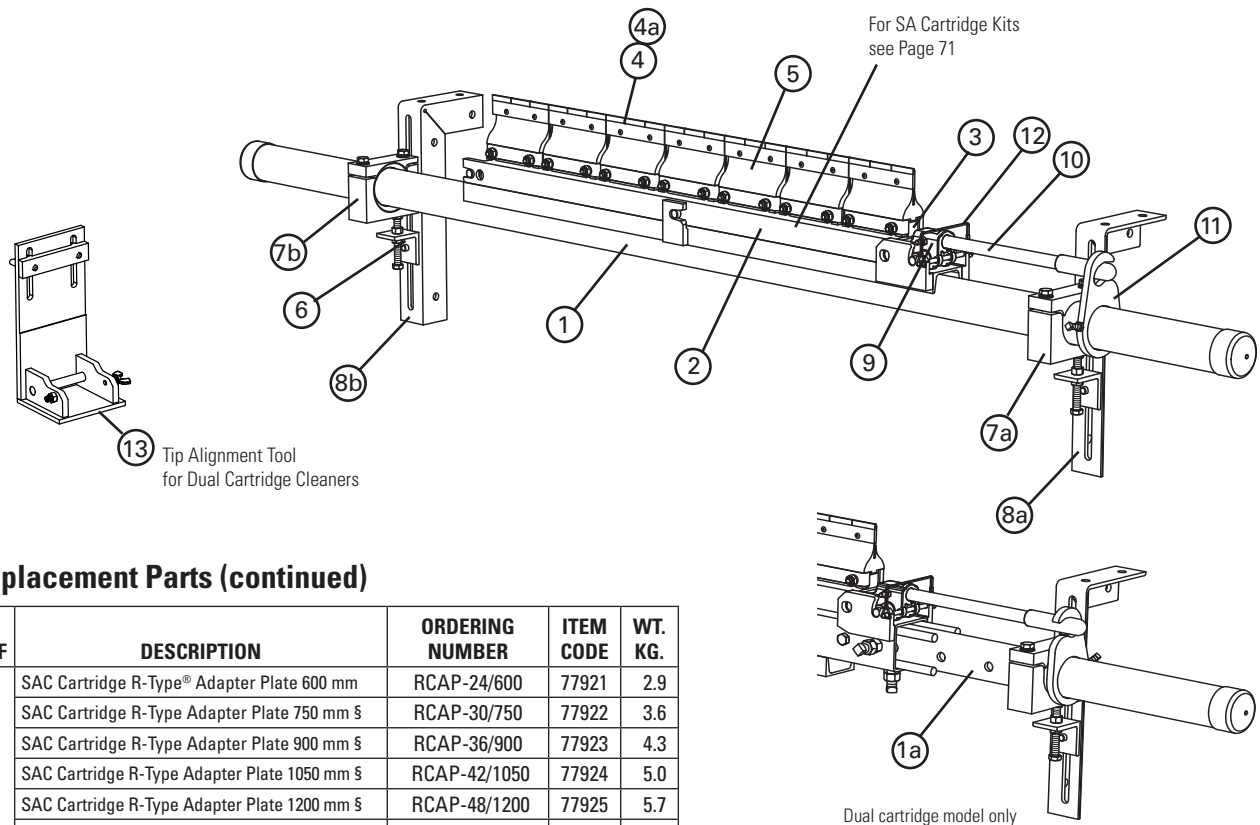

Replacement Parts (continued)

REF	DESCRIPTION	ORDERING NUMBER	ITEM CODE	WT. KG.
3	SAC Cartridge R-Type® Adapter Plate 600 mm	RCAP-24/600	77921	2.9
	SAC Cartridge R-Type Adapter Plate 750 mm §	RCAP-30/750	77922	3.6
	SAC Cartridge R-Type Adapter Plate 900 mm §	RCAP-36/900	77923	4.3
	SAC Cartridge R-Type Adapter Plate 1050 mm §	RCAP-42/1050	77924	5.0
	SAC Cartridge R-Type Adapter Plate 1200 mm §	RCAP-48/1200	77925	5.7
	SAC Cartridge R-Type Adapter Plate 1350 mm	RCAP-54/1350	77926	6.4
	SAC Cartridge R-Type Adapter Plate 1500 mm §	RCAP-60/1500	77927	7.2
	SAC Cartridge R-Type Adapter Plate 1800 mm	RCAP-72/1800	77928	8.6
4	C-Tip*	CT6	74535	0.4
4a	R V-Tip* (for vulcanised belts only)	RSA150	73628	0.4
5	Cushion*	RSA	76249	0.4
6	P/R Adjusting Bracket	PAB	75513	0.4
7a	Cradle Clamp Block RH	SMR-CCB-R73	A2843	1.2
7b	Cradle Clamp Block LH	SMR-CCB-L73	A2842	1.2
8a	Mounting Bracket Kit, RH	PMBR	75519	3.8
8b	Mounting Bracket Kit, LH	PMBL	75516	3.8
9	SAC Removal Knuckle	SACRKN	77882	1.5
10	SAC Removal Handle	SACRH	77883	1.4
11	SAC Handle Lock Plate	SACRHL	77884	0.8
12	Knuckle Retainer Pin	SACKRP	77885	0.1
-	SAC Removal Kit (includes 1 ea. items 9,10,11,12)	SACRKT	77886	4.1
13	SAC Cartridge Tip Alignment Tool (Dual)	SAC2-TIP-TL	77866	1.1
-	Cradle Clamp Heavy-Duty Mounting Kit (inc. 2 ea. items 6, 8; 1 ea. items 7a, 7b)	CRHMK	62400	10.8

§ If using a dual cartridge, please take the cleaner size and divide by two. That dimension is the size of the brackets needed for conversion to an R-Type cleaner.

Stock items (non-shaded) refer to (*) for specific lead time, if not specified, standard lead time applies.
Non-stock items (shaded) please contact Flexco for dispatch options and lead times.

Replacement Parts List

R-Type® SAC (Stainless Steel) Secondary Cleaner with Service Advantage Cartridge™

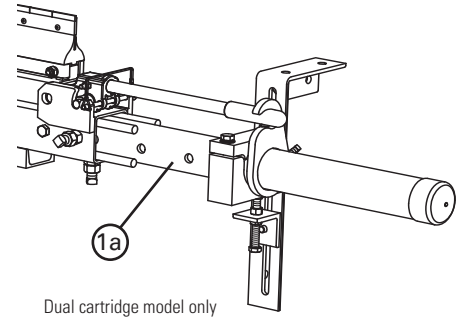
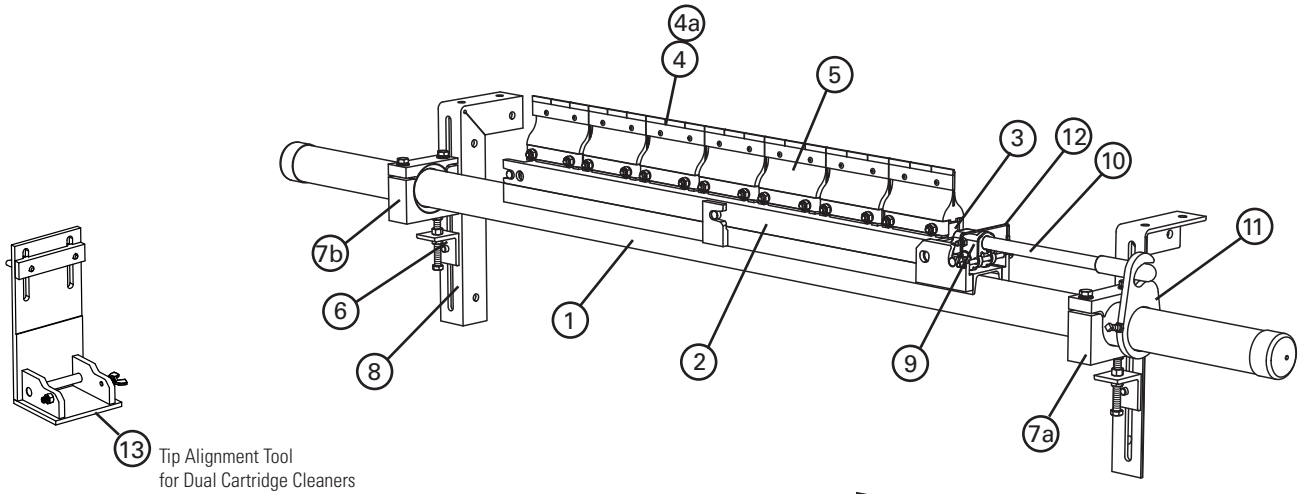

Replacement Parts

REF	DESCRIPTION	ORDERING NUMBER	ITEM CODE	WT. KG.
1	SAC S/S Cartridge Pole 600 mm	SACPL-24/600-S/S	78371	29.7
	SAC S/S Cartridge Pole 750 mm	SACPL-30/750-S/S	78372	32.3
	SAC S/S Cartridge Pole 900 mm	SACPL-36/900-S/S	78373	35.0
	SAC S/S Cartridge Pole 1050 mm	SACPL-42/1050-S/S	78374	37.6
	SAC S/S Cartridge Pole 1200 mm	SACPL-48/1200-S/S	78375	40.3
	SAC S/S Cartridge Pole 1350 mm	SACPL-54/1350-S/S	78376	42.9
	SAC S/S Cartridge Pole 1500 mm	SACPL-60/1500-S/S	78377	45.6
	SAC S/S Cartridge Pole 1800 mm	SACPL-72/1800-S/S	78378	50.9
	SAC S/S Cartridge Center Pole 1500 mm (Dual)	SACPL2-60/1500-S/S	78379	35.1
	SAC S/S Cartridge Center Pole 1800 mm (Dual)	SACPL2-72/1800-S/S	78380	40.6
	SAC S/S Cartridge Center Pole 1950 mm (Dual)	SACPL2-78/1950-S/S	78642	43.9
	SAC S/S Cartridge Center Pole 2100 mm (Dual)	SACPL2-84/2100-S/S	78381	46.2
	SAC S/S Cartridge Center Pole 2400 mm (Dual)	SACPL2-96/2400-S/S	78382	51.8
	SAC S/S Cartridge Center Pole 3000 mm (Dual)	SACPL2-120/3000-S/S	78383	64.5
1a	S/S Extender Pole (for use with S/S Dual Cartridge Center Pole)	MHP-EP-S/S	77599	24.5
2	SAC Repl Cartridge S/S 600 mm	CART-24/600-S/S	78576	4.5
	SAC Repl Cartridge S/S 750 mm	CART-30/750-S/S	78577	5.6
	SAC Repl Cartridge S/S 900 mm	CART-36/900-S/S	78578	6.7
	SAC Repl Cartridge S/S 1050 mm	CART-42/1050-S/S	78579	7.8
	SAC Repl Cartridge S/S 1200 mm	CART-48/1200-S/S	78580	8.9
	SAC Repl Cartridge S/S 1350 mm	CART-54/1350-S/S	78581	10.0
	SAC Repl Cartridge S/S 1500 mm	CART-60/1500-S/S	78582	11.3
	SAC Repl Cartridge S/S 1800 mm	CART-72/1800-S/S	78583	13.5
	SAC Repl Cartridge S/S 1500 mm (Dual)	CART2-60/1500-S/S	78584	11.2
	SAC Repl Cartridge S/S 1800 mm (Dual)	CART2-72/1800-S/S	78585	13.4
	SAC Repl Cartridge S/S 1950 mm (Dual)	CART2-78/1950-S/S	78635	14.5
	SAC Repl Cartridge S/S 2100 mm (Dual)	CART2-84/2100-S/S	78586	15.6
	SAC Repl Cartridge S/S 2400 mm (Dual)	CART2-96/2400-S/S	78587	17.8
	SAC Repl Cartridge S/S 3000 mm (Dual)	CART2-120/3000-S/S	78588	22.6

Stock items (non-shaded) refer to (*) for specific lead time, if not specified, standard lead time applies.
 Non-stock items (shaded) please contact Flexco for dispatch options and lead times.

Replacement Parts List

R-Type® SAC (Stainless Steel) Secondary Cleaner with Service Advantage Cartridge™

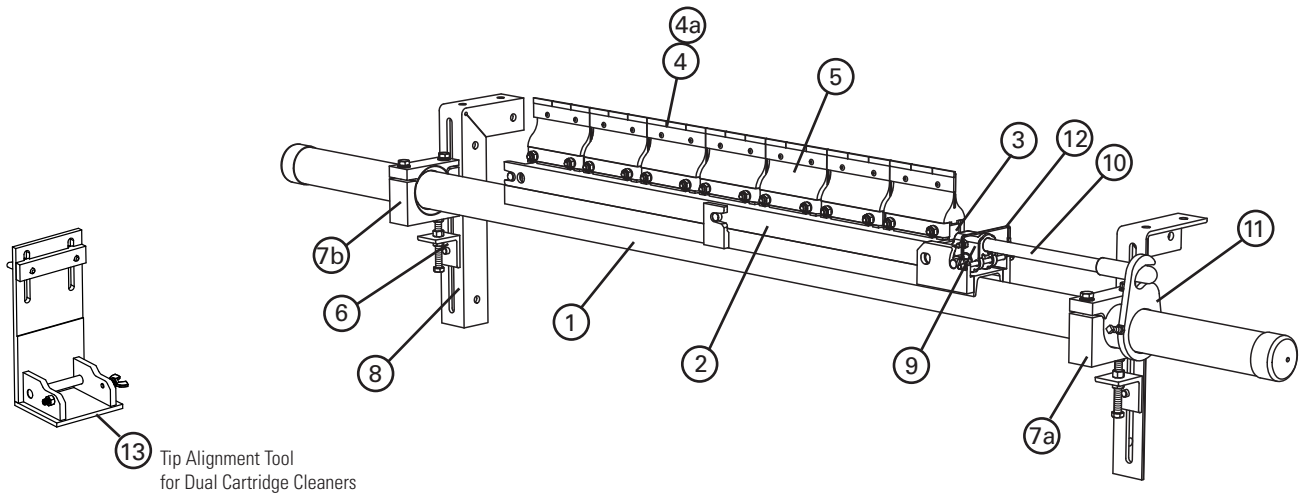

Replacement Parts (continued)

REF	DESCRIPTION	ORDERING NUMBER	ITEM CODE	WT. KG.
3	SAC Cartridge R-Type® S/S Adapter Plate 600 mm	RCAP-24/600-S/S	78363	2.9
	SAC Cartridge R-Type S/S Adapter Plate 750 mm §	RCAP-30/750-S/S	78364	3.6
	SAC Cartridge R-Type S/S Adapter Plate 900 mm §	RCAP-36/900-S/S	78365	4.3
	SAC Cartridge R-Type S/S Adapter Plate 1050 mm §	RCAP-42/1050-S/S	78366	5.0
	SAC Cartridge R-Type S/S Adapter Plate 1200 mm §	RCAP-48/1200-S/S	78367	5.7
	SAC Cartridge R-Type S/S Adapter Plate 1350 mm	RCAP-54/1350-S/S	78368	6.4
	SAC Cartridge R-Type S/S Adapter Plate 1500 mm §	RCAP-60/1500-S/S	78369	7.2
	SAC Cartridge R-Type S/S Adapter Plate 1800 mm	RCAP-72/1800-S/S	78370	8.6
4	C-Tip	CT6	74535	0.4
4a	S/S V-Tip* (for vulcanised belts only)	RVT6-S/S	76205	0.4
5	S/S R Cushion*	RC-S/S	76250	1.4
6	P/R Adjusting Bracket S/S	PAB-S/S	75515	0.4
7a	Cradle Clamp Block RH S/S	CRDLBLK-RH-S/S	A2825	1.2
7b	Cradle Clamp Block LH S/S	CRDLBLK-LH-S/S	A2826	1.2
8a	Mounting Bracket Kit RH S/S	PMBR-S/S	75521	3.8
8b	Mounting Bracket Kit LH S/S	PMBL-S/S	75518	3.8
9	SAC Removal Knuckle	SACRKN	77882	1.5
10	SAC Removal Handle S/S	SACRH-S/S	78397	1.4
11	SAC Handle Lock Plate S/S	SACRHL-S/S	78398	0.8
12	Knuckle Retainer Pin S/S	SACKRP-S/S	78399	0.1
-	SAC Removal Kit S/S (includes 1 ea. items 9,10,11,12)	SACRKT-S/S	78401	4.1
13	SAC Cartridge Tip Alignment Tool (Dual)	SAC2-TIP-TL	77866	1.1
-	Cradle Clamp Stainless Steel Heavy-Duty Mounting Kit (incl. 2 ea. item 6; incl. 1 ea. items 7a, 7b, 8a, 8b)	CRHMK-S/S	62095	10.8

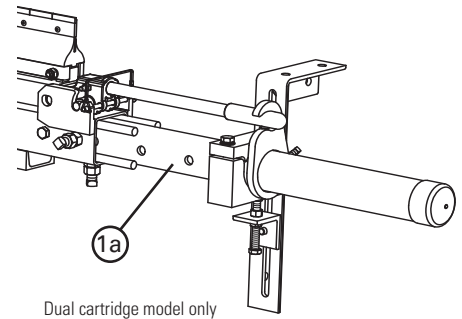

§ If using a dual cartridge, please take the cleaner size and divide by two. That dimension is the size of the brackets needed for conversion to an R-Type cleaner.

Stock items (non-shaded) refer to (*) for specific lead time, if not specified, standard lead time applies.
 Non-stock items (shaded) please contact Flexco for dispatch options and lead times.

Specifications & Guidelines

R-Type® SAC Secondary Cleaner with Service Advantage Cartridge™

Pole Length Specifications*

VERSION	CLEANER SIZE mm	BLADE WIDTH mm	POLE LENGTH mm	MAXIMUM CONVEYOR SPAN mm
Single	600	600	1950	1650
	750	750	2100	1800
	900	900	2250	1950
	1050	1050	2400	2100
	1200	1200	2550	2250
	1350	1350	2700	2400
	1500	1500	2850	2550
	1800	1800	3150	2850
Dual	1500	1500	3000	2700
	1800	1800	3300	3000
	2100	2100	3600	3300
	2400	2400	3900	3600
	3000	3000	4500	4200

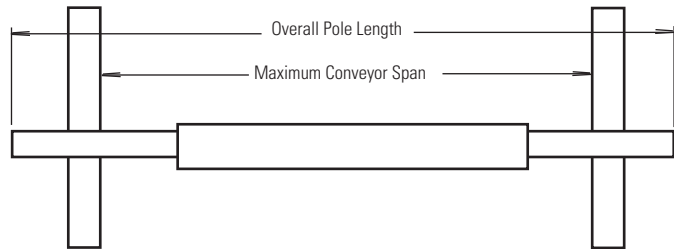

*For special extra long pole length requirements a Pole Extender Kit (#76024) is available that provides 750 mm of extended pole length. Pole Diameter - 73 mm

Clearance Guidelines for Installation

VERSION	HORIZONTAL CLEARANCE REQUIRED mm	VERTICAL CLEARANCE REQUIRED mm
Single	114	254
Dual	114	298

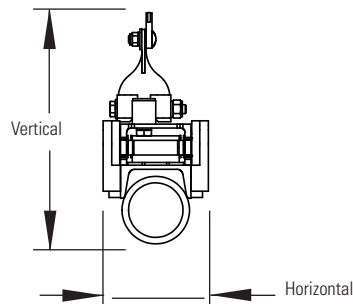

Specifications:

- Maximum Belt Speed5M/sec
- Temperature Rating-35°C to 82°C
- Usable Blade Wear Length.....9 mm
- Blade MaterialsC-Tip: Impact Resistant Tungsten Carbide (works with mechanical fasteners)
V-Tip: Long Life Tungsten Carbide (for vulcanised belts only)
- Available for Belt Widths600 to 3000 mm. Other sizes available upon request.

U.S. Patent Pending

Product Ordering Information

MHS SAC HD Secondary Cleaner with Service Advantage Cartridge™

MHS SAC Secondary with V-Tips*

BELT WIDTH mm	ORDERING NUMBER	ITEM CODE	WT. KG.
600	MHS-600V-SAC	78162	88.5
750	MHS-750V-SAC	78163	93.7
900	MHS-900V-SAC	78164	99.1
1050	MHS-1050V-SAC	78165	104.4
1200	MHS-1200V-SAC	78166	109.6
1350	MHS-1350V-SAC	78167	114.8
1500	MHS-1500V-SAC	78168	120.2
1800	MHS-1800V-SAC	78169	130.8
1500	MHS-1500V-2SAC	78170	140.2
1800	MHS-1800V-2SAC	78171	151.0
2100	MHS-2100V-2SAC	78172	161.8
2400	MHS-2400V-2SAC	78173	172.9
3000	MHS-3000V-2SAC	78174	196.2

*NOTE: V-Tips can be used ONLY on vulcanised belts.

MHS SAC Stainless Steel Secondary with V-Tips*

BELT WIDTH mm	ORDERING NUMBER	ITEM CODE	WT. KG.
600	MHS-600V-SAC-S/S	78537	88.5
750	MHS-750V-SAC-S/S	78538	93.7
900	MHS-900V-SAC-S/S	78539	99.1
1050	MHS-1050V-SAC-S/S	78540	104.4
1200	MHS-1200V-SAC-S/S	78541	109.6
1350	MHS-1350V-SAC-S/S	78542	114.8
1500	MHS-1500V-SAC-S/S	78543	120.2
1800	MHS-1800V-SAC-S/S	78544	130.8
1500	MHS-1500V-2SAC-S/S	78545	140.2
1800	MHS-1800V-2SAC-S/S	78546	151.0
1950	MHS-1950V-2SAC-S/S	78649	156.0
2100	MHS-2100V-2SAC-S/S	78547	161.8
2400	MHS-2400V-2SAC-S/S	78548	172.9
3000	MHS-3000V-2SAC-S/S	78549	196.2

*NOTE: V-Tips can be used ONLY on vulcanised belts.

Product Notes:

- Patent-pending Service Advantage Cartridge™ allows for easy removal in even the dirtiest conditions.
- Heavy-duty design to deliver maximum cleaning efficiency on the most demanding, abusive beltlines.
- Pole Length: Belt width plus 1350 mm (single cartridge cleaners); Belt width plus 1500 mm (dual cartridge cleaners).
- Patented PowerFlex™ cushion design to maintain continuous blade-to-belt contact and quick relief from passing mechanical splices.
- C-Tips are for mechanically fastened or vulcanised belts. V-Tips are for vulcanised belts only.
- Visual Blade Tension Check: Measure the tension spring and refer to Spring Length Chart on mounting base for the correct length for best cleaning performance.
- Tensioner mounting brackets included for fast and easy installation.
- Cartridge Removal Kit included for easy removal of the cartridge.

U.S. Patent Pending

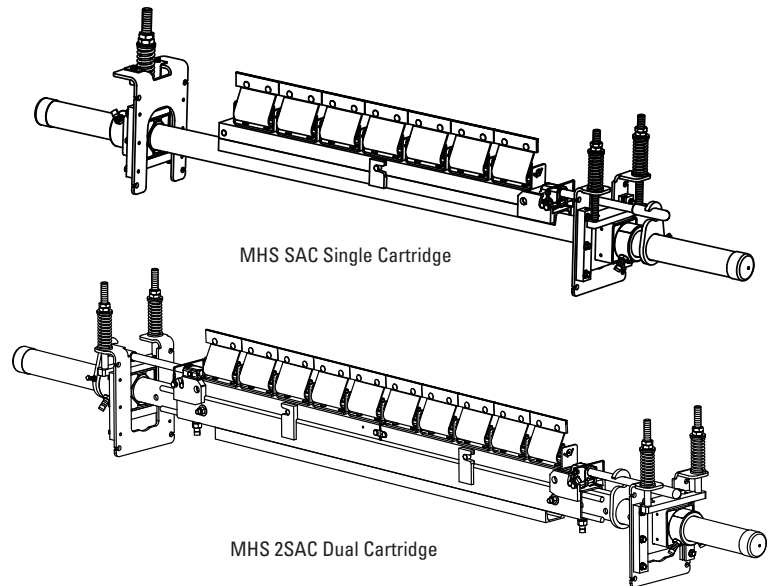

Replacement Tips

ORDERING NUMBER	ITEM CODE	WT. KG.
CT6 (C-Tip)	74535	0.4
RSA150 (V-Tip)	73628	0.4

Tips Required Per Cleaner Size

BELT WIDTH mm	BLADE COVERAGE mm	V-TIPS REQUIRED
600	600	4
750	750	5
900	900	6
1050	1050	7
1200	1200	8
1350	1350	9
1500	1500	10
1800	1800	12
2100	2100	14
2400	2400	16
3000	3000	20

Stock items (non-shaded) refer to (*) for specific lead time, if not specified, standard lead time applies.

Non-stock items (shaded) please contact Flexco for dispatch options and lead times.

Product Ordering Information

MHS SAC
HD Secondary Cleaner
 with Service Advantage Cartridge™

MHS SAC Cartridge Kits with V-Tips*

BELT WIDTH mm	ORDERING NUMBER	ITEM CODE	WT. KG.
600	MHS-CARK-V24/600	77937	13.3
750	MHS-CARK-V30/750	77938	15.9
900	MHS-CARK-V36/900	77939	18.5
1050	MHS-CARK-V42/1050	77940	21.1
1200	MHS-CARK-V48/1200	77941	23.7
1350	MHS-CARK-V54/1350	77942	26.3
1500	MHS-CARK-V60/1500	77943	28.9
1800	MHS-CARK-V72/1800	77944	34.2
1500	MHS-CARK2-V60/1500	77950	31.8
1800	MHS-CARK2-V72/1800	77951	37.0
2100	MHS-CARK2-V84/2100	77952	42.2
2400	MHS-CARK2-V96/2400	77953	47.4
3000	MHS-CARK2-V120/3000	77954	57.9

*NOTE: V-Tips can be used ONLY on vulcanised belts.

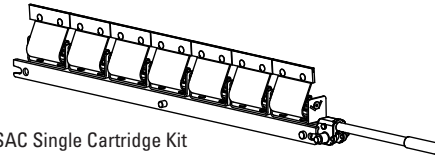

MHS SAC Single Cartridge Kit

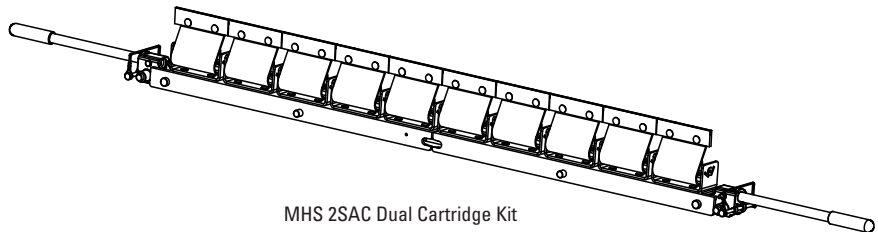



MHS 2SAC Dual Cartridge Kit

MHS SAC Stainless Steel Cartridge Kits with V-Tips*

BELT WIDTH mm	ORDERING NUMBER	ITEM CODE	WT. KG.
600	MHS-CARK-V24/600-S/S MVECKS/S	82841	13.3
750	MHS-CARK-V30/750-S/S MVECKS/S	82842	15.9
900	MHS-CARK-V36/900-S/S MVECKS/S	82843	18.5
1050	MHS-CARK-V42/1050-S/S MVECKS/S	82844	21.1
1200	MHS-CARK-V48/1200-S/S MVECKS/S	82845	23.7
1350	MHS-CARK-V54/1350-S/S MVECKS/S	82846	26.3
1500	MHS-CARK-V60/1500-S/S MVECKS/S	82847	28.9
1800	MHS-CARK-V72/1800-S/S MVECKS/S	82848	34.2
1500	MHS-CARK2-V60/1500-S/S MV2CKSS	82849	31.8
1800	MHS-CARK2-V72/1800-S/S MV2CKSS	82850	37.0
2100	MHS-CARK2-V84/2100-S/S MV2CKSS	82851	42.2
2400	MHS-CARK2-V96/2400-S/S MV2CKSS	82852	47.4
3000	MHS-CARK2-V120/3000-S/S MV2CKS	82853	57.9

*NOTE: V-Tips can be used ONLY on vulcanised belts.

 **Stock items** (non-shaded) refer to (*) for specific lead time, if not specified, standard lead time applies.

 **Non-stock items** (shaded) please contact Flexco for dispatch options and lead times.

U.S. Patent Pending

Replacement Parts List

MHS SAC (Mild Steel) HD Secondary Cleaner with Service Advantage Cartridge™

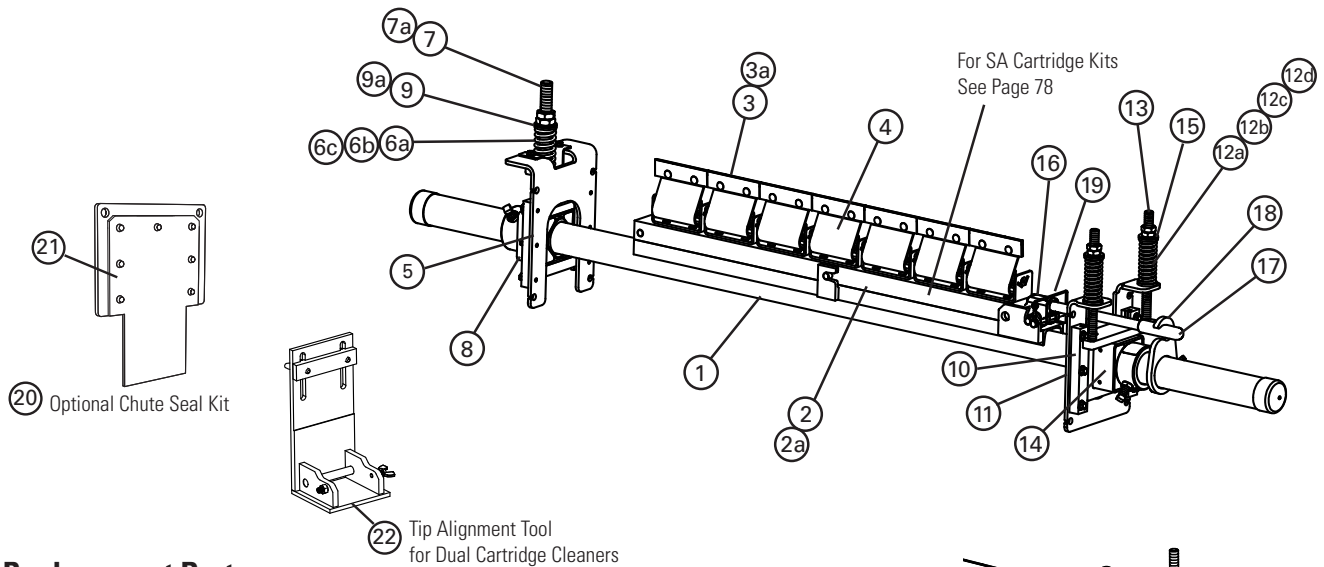

Replacement Parts

REF	DESCRIPTION	ORDERING NUMBER	ITEM CODE	WT. KG.
1	SAC Cartridge Pole 600mm	SACPL-24/600	77887	29.7
	SAC Cartridge Pole 750mm	SACPL-30/750	77888	32.3
	SAC Cartridge Pole 900mm	SACPL-36/900	77889	35.0
	SAC Cartridge Pole 1050mm	SACPL-42/1050	77890	37.6
	SAC Cartridge Pole 1200mm	SACPL-48/1200	77891	40.3
	SAC Cartridge Pole 1350mm	SACPL-54/1350	77892	42.9
	SAC Cartridge Pole 1500mm	SACPL-60/1500	77893	45.6
	SAC Cartridge Pole 1800mm	SACPL-72/1800	77894	50.9
	SAC Cartridge Center Pole 1500mm (Dual)	SACPL2-60/1500	77895	35.1
	SAC Cartridge Center Pole 1800mm (Dual)	SACPL2-72/1800	77896	40.6
	SAC Cartridge Center Pole 2100mm (Dual)	SACPL2-84/2100	77897	46.2
	SAC Cartridge Center Pole 2400mm (Dual)	SACPL2-96/2400	77898	51.8
	SAC Cartridge Center Pole 3000mm (Dual)	SACPL2-120/3000	77899	64.5
1a	Extender Pole (for use with Dual Cartridge Center Pole)	MHP-EP	76392	24.5
2	SAC Repl Cartridge S/S 600 mm	CART-24/600-S/S	78576	4.5
	SAC Repl Cartridge S/S 750 mm	CART-30/750-S/S	78577	5.6
	SAC Repl Cartridge S/S 900 mm	CART-36/900-S/S	78578	6.7
	SAC Repl Cartridge S/S 1050 mm	CART-42/1050-S/S	78579	7.8
	SAC Repl Cartridge S/S 1200 mm	CART-48/1200-S/S	78580	8.9
	SAC Repl Cartridge S/S 1350 mm	CART-54/1350-S/S	78581	10.0
	SAC Repl Cartridge S/S 1500 mm	CART-60/1500-S/S	78582	11.3
	SAC Repl Cartridge S/S 1800 mm	CART-72/1800-S/S	78583	13.5
	SAC Repl Cartridge S/S 1500 mm (Dual)	CART2-60/1500-S/S	78584	11.2
	SAC Repl Cartridge S/S 1800 mm (Dual)	CART2-72/1800-S/S	78585	13.4
	SAC Repl Cartridge S/S 1950 mm (Dual)	CART2-78/1950-S/S	78635	14.5
	SAC Repl Cartridge S/S 2100 mm (Dual)	CART2-84/2100-S/S	78586	15.6
	SAC Repl Cartridge S/S 2400 mm (Dual)	CART2-96/2400-S/S	78587	17.8
SAC Repl Cartridge S/S 3000 mm (Dual)	CART2-120/3000-S/S	78588	22.6	
3	C-Tip*	CT6	74535	0.4
3a	V-Tip* (for vulcanised belts only)	RSA150	73628	0.4
4	PowerFlex™ Cushion*	SPFC	79200	0.9
5	SST HD Mounting Base Kit* (includes 1 mounting base and 2 slide guides)	SSTHDMK	77870	4.6

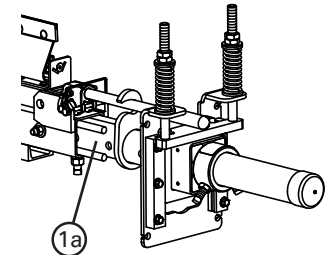

Dual cartridge model only

Stock items (non-shaded) refer to (*) for specific lead time, if not specified, standard lead time applies.
Non-stock items (shaded) please contact Flexco for dispatch options and lead times.

Replacement Parts List

MHS SAC (Mild Steel) HD® Secondary Cleaner with Service Advantage Cartridge™

Replacement Parts (continued)

REF	DESCRIPTION	ORDERING NUMBER	ITEM CODE	WT. KG.
6a	SST Spring - White (1 ea.) for belts 450-750mm	STS-W	75846	0.2
6b	SST Spring - Silver (1 ea.) for belts 900-1500mm	STS-S	75843	0.4
6c	SST Spring - Black (1 ea.) for belts 1800-2100mm	STS-B	75844	0.5
6d	SST Spring - Gold (1 ea.) for belts over 2100mm	STS-G	78142	0.7
7	SST Adj Rod Kit*(incl. 1 rod, 2 nuts, 2 bushings, 1 washer) for belts 450-1500 mm	STAK	75847	1.3
7a	SST HD® Adj Rod Kit*(incl. 1 rod, 2 nuts, 2 HD bushings, 1 washer) for belts 1800-2100mm	STAKHD	75892	1.4
8	SST HD Torsion Pole Mount* (1 ea.)	SSTHDPM	77868	6.8
9	SST Bushing Kit - White/Silver	SSTBK-W	76636	0.1
9a	SST Bushing Kit - Black	SSTBK-B	76637	0.1
10	ST Slide Guide Kit	STGK2	77635	0.5
-	SST HD Cartridge Tensioner - White (includes 1 ea. item 5, 6a, 7, 8) for belts 450-750 mm	SST1HDM-W	78517	13.7
-	SST HD Cartridge Tensioner - Silver (includes 1 ea. item 5, 6b, 7, 8) for belts 900-1500 mm	SST1HDM-S	78518	13.9
-	SST HD Cartridge Tensioner - Black (includes 1 ea. item 5, 6c, 7a, 8) for belts 1800-2100 mm	SST1HDM-B	78519	14.1
-	SST HD Cartridge Tensioner - Gold (includes 1 ea. item 5, 6d, 7a, 8) for belts over 2100 mm	SST1HDM-G	79069	14.3
11	CST HD Mounting Base Kit*	CSTHDMK	77871	3.9
12a	CST Spring - White (1 ea.) for belts 450-750 mm	CTS-W	77742	0.2
12b	CST Spring - Silver (1 ea.) for belts 900-1500 mm	CTS-S	77743	0.2
12c	CST Spring - Black (1 ea.) for belts 1800-2100 mm	CTS-B	77744	0.3
12d	CST Spring - Gold (1 ea.) for belts 2400-3000 mm	CTS-G	77745	0.4

REF	DESCRIPTION	ORDERING NUMBER	ITEM CODE	WT. KG.
13	CST Adj Rod Kit (incl. 2 rods, 4 nuts, 4 bushings, 2 washers)	CSTAK	77031	1.5
14	CST HD Torsion Pole Mount* (1 ea.)	CSTHDPM	77869	7.4
15	CST Bushing Kit (includes 4 bushings)	CSTBK	77037	0.1
-	CST HD Cartridge Tensioner - White (incl. 1 ea. item 11,13,14 and 2 ea. item 12) for belts 450-750 mm	CST1HDM-W	78513	13.7
-	CST HD Cartridge Tensioner - Silver (incl. 1 ea. item 11,13,14 and 2 ea. item 12a) for belts 900-1500 mm	CST1HDM-S	78514	13.7
-	CST HD Cartridge Tensioner - Black (includes 1 ea. item 11,13,14 and 2 ea. item 12b) for belts 1800-2100 mm	CST1HDM-B	78515	13.7
-	CST HD Cartridge Tensioner - Gold (includes 1 ea. item 11,13,14 and 2 ea. item 12c) for belts 2400-3000 mm	CST1HDM-G	78516	13.9
16	SAC Removal Knuckle	SACRKN	77882	1.5
17	SAC Removal Handle	SACRH	77883	1.4
18	SAC Handle Lock Plate	SACRHL	77884	0.8
19	Knuckle Retainer Pin	SACKRP	77885	0.1
-	SAC Removal Kit (includes 1 ea. items 16,17,18,19)	SACRKT	77886	4.1
20	SAC Chute Seal Kit	SACSK	77052	1.8
21	SAC Chute Seal Replacement Cover	SACSRC	77065	0.2
22	SAC Cartridge Tip Alignment Tool (Dual)	SAC2-TIP-TL	77866	1.1

ATV Replacement Parts

REF	DESCRIPTION	ORDERING NUMBER	ITEM CODE	WT. KG.
1	Mounting Bracket LH	PMBL-S/S	75518	3.8
2	Mounting Bracket RH	PMBR-S/S	75521	3.8
3	Air Tensioner Slider	ATV-SLIDE	62425	0.2
4	Air Tension Cradle Blocks 60mm Kit	ATV-MOUNT	62424	2.4
5	Air Tension Cradle Blocks 73mm Kit	ATV-MOUNT	63073	2.4
6	Air Tension Adjusting Angle	ATV-ANGLE	62426	1.0
7	Air Bag	ATV-BAG	62036	0.2
8	Hex Nut S/S	HEX NUT	G1211	0.1
9	Air Line Adaptor	ATV-NIP	62037	0.1
10	PAT Control Box 60psi	PACB60	78683	5.0
11	PAT Control Box 100psi	PACB100	79656	5.0
-	Secondary Air Tension 60mm Complete Kit	ATVK-60	62409	13.0
-	Secondary Air Tension 73mm Complete Kit	ATVK-73	63072	15.0

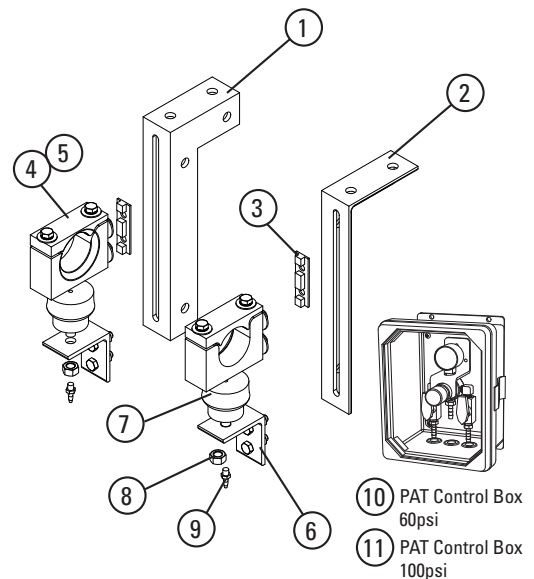

Stock items (non-shaded) refer to (*) for specific lead time, if not specified, standard lead time applies.
Non-stock items (shaded) please contact Flexco for dispatch options and lead times.

Replacement Parts List

MHS SAC (Stainless Steel) HD® Secondary Cleaner with Service Advantage Cartridge™

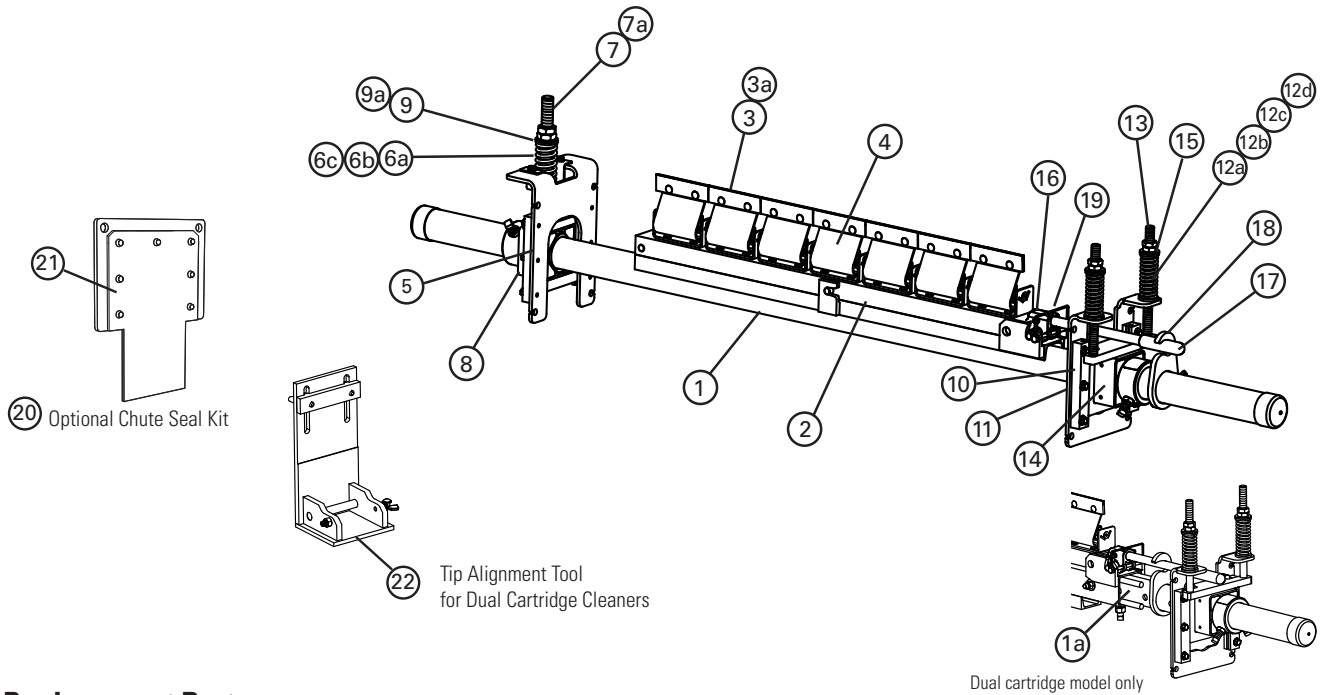

Replacement Parts

REF	DESCRIPTION	ORDERING NUMBER	ITEM CODE	WT. KG.	
1	SAC S/S Cartridge Pole 600mm	SACPL-24/600-S/S	78371	29.7	
	SAC S/S Cartridge Pole 750mm	SACPL-30/750-S/S	78372	32.3	
	SAC S/S Cartridge Pole 900mm	SACPL-36/900-S/S	78373	35.0	
	SAC S/S Cartridge Pole 1050mm	SACPL-42/1050-S/S	78374	37.6	
	SAC S/S Cartridge Pole 1200mm	SACPL-48/1200-S/S	78375	40.3	
	SAC S/S Cartridge Pole 1350mm	SACPL-54/1350-S/S	78376	42.9	
	SAC S/S Cartridge Pole 1500mm	SACPL-60/1500-S/S	78377	45.6	
	SAC S/S Cartridge Pole 1800mm	SACPL-72/1800-S/S	78378	50.9	
	SAC S/S Cartridge Center Pole 1500mm (Dual)	SACPL2-60/1500-S/S	78379	35.1	
	SAC S/S Cartridge Center Pole 1800mm (Dual)	SACPL2-72/1800-S/S	78380	40.6	
	SAC S/S Cartridge Center Pole 1950mm (Dual)	SACPL2-78/1950-S/S	78642	43.9	
	SAC S/S Cartridge Center Pole 2100mm (Dual)	SACPL2-84/2100-S/S	78381	46.2	
	SAC S/S Cartridge Center Pole 2400mm (Dual)	SACPL2-96/2400-S/S	78382	51.8	
	SAC S/S Cartridge Center Pole 3000mm (Dual)	SACPL2-120/3000-S/S	78383	64.5	
	1a	S/S Extender Pole (for use with S/S Dual Cartridge Center Pole)	MHP-EP-S/S	77599	24.5

REF	DESCRIPTION	ORDERING NUMBER	ITEM CODE	WT. KG.
2	SAC Repl Cartridge S/S 600 mm	CART-24/600-S/S	78576	4.5
	SAC Repl Cartridge S/S 750 mm	CART-30/750-S/S	78577	5.6
	SAC Repl Cartridge S/S 900 mm	CART-36/900-S/S	78578	6.7
	SAC Repl Cartridge S/S 1050 mm	CART-42/1050-S/S	78579	7.8
	SAC Repl Cartridge S/S 1200 mm	CART-48/1200-S/S	78580	8.9
	SAC Repl Cartridge S/S 1350 mm	CART-54/1350-S/S	78581	10.0
	SAC Repl Cartridge S/S 1500 mm	CART-60/1500-S/S	78582	11.3
	SAC Repl Cartridge S/S 1800 mm	CART-72/1800-S/S	78583	13.5
	SAC Repl Cartridge S/S 1500 mm (Dual)	CART2-60/1500-S/S	78584	11.2
	SAC Repl Cartridge S/S 1800 mm (Dual)	CART2-72/1800-S/S	78585	13.4
	SAC Repl Cartridge S/S 1950 mm (Dual)	CART2-78/1950-S/S	78635	14.5
	SAC Repl Cartridge S/S 2100 mm (Dual)	CART2-84/2100-S/S	78586	15.6
	SAC Repl Cartridge S/S 2400 mm (Dual)	CART2-96/2400-S/S	78587	17.8
	SAC Repl Cartridge S/S 3000 mm (Dual)	CART2-120/3000-S/S	78588	22.6

Stock items (non-shaded) refer to (*) for specific lead time, if not specified, standard lead time applies.

Non-stock items (shaded) please contact Flexco for dispatch options and lead times.

Replacement Parts List

MHS SAC (Stainless Steel)
HD® Secondary Cleaner
 with Service Advantage Cartridge™

Replacement Parts (continued)

REF	DESCRIPTION	ORDERING NUMBER	ITEM CODE	WT. KG.
3	C-Tip	CT6	74535	0.4
3a	S/S V-Tip* (for vulcanised belts only)	RVT6-S/S	76205	0.4
4	PowerFlex™ Cushion, S/S*	SPFC-S/S	79201	0.9
5	SST HD® Mounting Base Kit, S/S*	STHDMK2-S/S	77634	4.6
6a	SST Spring - White S/S (1 ea.)	STS-W-S/S	77630	0.2
6b	SST Spring - Silver S/S (1 ea.)	STS-S-S/S	77631	0.4
6c	SST Spring - Black S/S (1 ea.)	STS-B-S/S	77632	0.5
7	SST Adj Rod Kit*(incl. 1 rod, 2 nuts, 2 bushings, 1 washer) for belts 450-1500 mm	STAK	75847	1.3
7a	SST HD Adj Rod Kit*(incl. 1 rod, 2 nuts, 2 HD bushings, 1 washer) for belts 1800-2100mm	STAKHD	75892	1.4
8	SST HD Torsion Pole Mount S/S* (1 ea.)	STHDPM2-S/S	77633	6.8
9	SST Bushing Kit - White/Silver	SSTBK-W	76636	0.1
9a	SST Bushing Kit - Black	SSTBK-B	76637	0.1
10	ST Slide Guide Kit	STGK2	77635	0.5
-	SST HD Cartridge Tensioner S/S - White (includes 1 ea. item 5, 6a, 7, 9) for belts 450-750 mm	SST1HDM-W-S/S	78394	13.7
-	SST HD Cartridge Tensioner S/S - Silver (includes 1 ea. item 5, 6b, 7, 9) for belts 900-1500 mm	SST1HDM-S-S/S	78395	13.9
-	SST HD Cartridge Tensioner S/S - Black (includes 1 ea. item 5, 6c, 7a, 9a) for belts 1800-2100 mm	SST1HDM-B-S/S	78396	14.1
11	CST HD Mounting Base Kit S/S*	CSTHDMK-S/S	78384	3.9
12a	CST Spring - White S/S (1 ea.) for belts 450-750 mm	CTS-W-S/S	78385	0.2
12b	CST Spring - Silver S/S (1 ea.) for belts 900-1500 mm	CTS-S-S/S	78386	0.2
12c	CST Spring - Black S/S (1 ea.) for belts 1800-2100 mm	CTS-B-S/S	78387	0.3
12d	CST Spring - Gold S/S (1 ea.) for belts 2400-3000 mm	CTS-G-S/S	78388	0.4
13	CST Adj Rod Kit (incl. 2 rods, 4 nuts, 4 bushings, 2 washers)	CSTAK	77031	1.5
14	CST HD Torsion Pole Mount S/S* (1 ea.)	CSTHDPM-S/S	78389	7.4
15	CST Bushing Kit (includes 4 bushings)	CSTBK	77037	0.1
-	CST HD Cartridge Tensioner S/S - White (incl. 1 ea. item 11,13,14 and 2 ea. item 12a) for belts 450-750 mm	CST1HDM-W-S/S	78390	13.7
-	CST HD Cartridge Tensioner S/S - Silver (incl. 1 ea. item 11,13,14 and 2 ea. item 12b) for belts 900-1500 mm	CST1HDM-S-S/S	78391	13.7
-	CST HD Cartridge Tensioner S/S - Black (includes 1 ea. item 11,13,14 and 2 ea. item 12c) for belts 1800-2100 mm	CST1HDM-B-S/S	78392	13.7
-	CST HD Cartridge Tensioner S/S - Gold (includes 1 ea. item 11,13,14 and 2 ea. item 12d) for belts 2400-3000 mm	CST1HDM-G-S/S	78393	13.9
16	SAC Removal Knuckle	SACRKN	77882	1.5
17	SAC Removal Handle S/S	SACRH-S/S	78397	1.4
18	SAC Handle Lock Plate S/S	SACRHL-S/S	78398	0.8
19	Knuckle Retainer Pin S/S	SACKRP-S/S	78399	0.1
-	SAC Removal Kit S/S (includes 1 ea. items 16,17,18,19)	SACRKT-S/S	78401	4.1
20	SAC Chute Seal Kit	SACSK	77052	1.8
21	SAC Chute Seal Replacement Cover	SACSRC	77065	0.2
22	SAC Cartridge Tip Alignment Tool (Dual)	SAC2-TIP-TL	77866	1.1

Stock items (non-shaded) refer to (*) for specific lead time, if not specified, standard lead time applies.

Non-stock items (shaded) please contact Flexco for dispatch options and lead times.

Specifications & Guidelines

MHS SAC
HD® Secondary Cleaner
with Service Advantage Cartridge™

Pole Length Specifications*

VERSION	CLEANER SIZE mm	BLADE WIDTH mm	POLE LENGTH mm	MAXIMUM CONVEYOR SPAN mm
Single	600	600	1950	1650
	750	750	2100	1800
	900	900	2250	1950
	1050	1050	2400	2100
	1200	1200	2550	2250
	1350	1350	2700	2400
	1500	1500	2850	2550
Dual	1500	1500	3000	2700
	1800	1800	3300	3000
	2100	2100	3600	3300
	2400	2400	3900	3600
	3000	3000	4500	4200

*For special extra long pole length requirements a Pole Extender Kit (#76024) is available that provides 750 mm of extended pole length. Pole Diameter - 73 mm

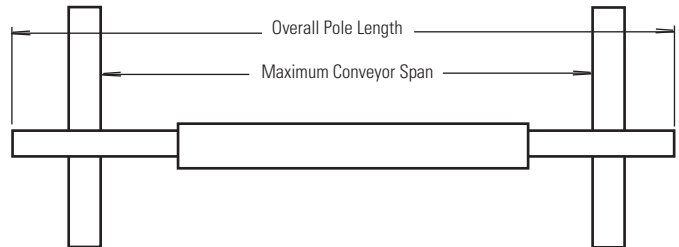

Clearance Guidelines for Installation

VERSION	HORIZONTAL CLEARANCE REQUIRED mm	VERTICAL CLEARANCE REQUIRED mm
Single	114	279
Dual	114	318

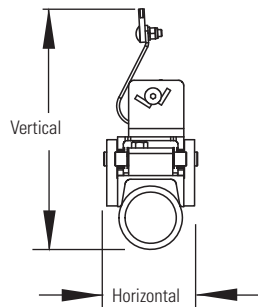

Aluminum Content

ALUMINUM ALLOY TYPE	PERCENT	
	MG MAGNESIUM	TI TITANIUM
6061	1.0%	0.0%

Spring Length Chart for SST Spring Tensioner (mm)

BLADE WIDTH	WHITE SPRING	SILVER SPRING	BLACK SPRING
600	78	99	N/A
750	72	97	N/A
900	N/A	94	98
1050	N/A	91	95
1200	N/A	88	93
1350	N/A	86	91
1500	N/A	83	89
1800	N/A	N/A	84

Shading indicates preferred spring option

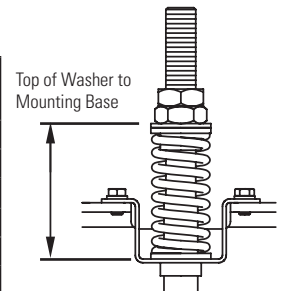

Spring Length Chart for CST Spring Tensioner (mm)

BLADE WIDTH	WHITE SPRING	SILVER SPRING	BLACK SPRING	GOLD SPRING
600	78	99	N/A	N/A
750	72	97	N/A	N/A
900	N/A	94	98	N/A
1050	N/A	91	95	N/A
1200	N/A	88	93	N/A
1350	N/A	86	91	N/A
1500	N/A	83	89	103
1800	N/A	N/A	84	101
2100	N/A	N/A	80	99
2400	N/A	N/A	N/A	97
3000	N/A	N/A	N/A	93

Shading indicates preferred spring option

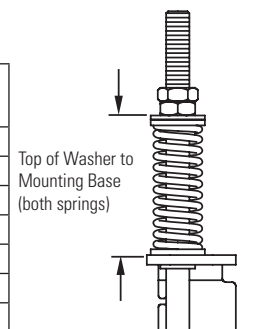

Specifications:

- Maximum Belt Speed 6M/sec
- Temperature Rating..... -35°C to 82°C
- Usable Blade Wear Length..... 9mm
- Blade Materials..... C-Tip: Impact Resistant Tungsten Carbide (works with mechanical fasteners)
V-Tip: Long Life Tungsten Carbide (for vulcanised belts only)
- Available for Belt Widths..... 600 to 3000 mm. Other sizes available upon request.

U.S. Patent Pending

Product Ordering Information

MHS SAC BT HD[®] Secondary Cleaner with Service Advantage Cartridge™ & Bolt Tensioner

MHS SAC Secondary with V-Tips*

BELT WIDTH mm	ORDERING NUMBER	ITEM CODE	WT. KG.
600	MHS-600BTV-SAC	78007	61.4
750	MHS-750BTV-SAC	78008	66.4
900	MHS-900BTV-SAC	78009	71.6
1050	MHS-1050BTV-SAC	78010	77.2
1200	MHS-1200BTV-SAC	78011	82.0
1350	MHS-1350BTV-SAC	78012	87.1
1500	MHS-1500BTV-SAC	78013	92.4
1800	MHS-1800BTV-SAC	78014	102.7
1500	MHS-1500BTV-2SAC	78015	105.2
1800	MHS-1800BTV-2SAC	78016	120.7
2100	MHS-2100BTV-2SAC	78017	131.4
2400	MHS-2400BTV-2SAC	78018	142.0
3000	MHS-3000BTV-2SAC	78019	165.0

*NOTE: V-Tips can be used ONLY on vulcanised belts.

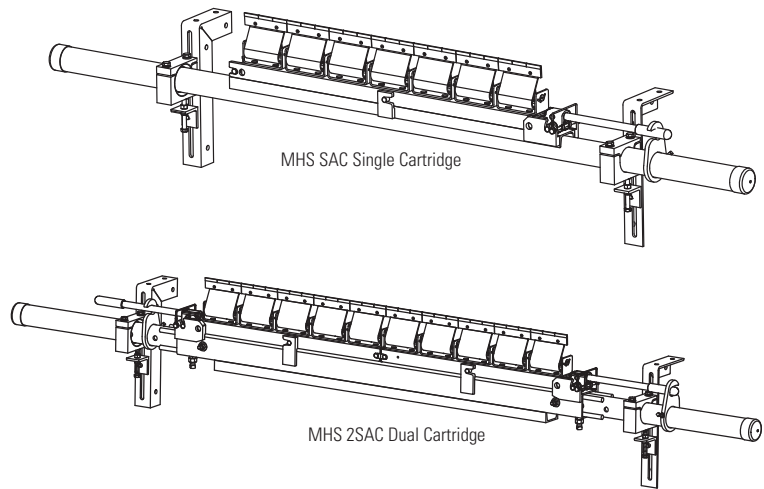

MHS SAC Stainless Steel Secondary with V-Tips*

BELT WIDTH mm	ORDERING NUMBER	ITEM CODE	WT. KG.
600	MHS-600BTV-SAC-S/S	78316	61.4
750	MHS-750BTV-SAC-S/S	78317	66.4
900	MHS-900BTV-SAC-S/S	78318	71.6
1050	MHS-1050BTV-SAC-S/S	78319	77.2
1200	MHS-1200BTV-SAC-S/S	78320	82.0
1350	MHS-1350BTV-SAC-S/S	78321	87.1
1500	MHS-1500BTV-SAC-S/S	78322	92.4
1800	MHS-1800BTV-SAC-S/S	78323	102.7
1500	MHS-1500BTV-2SAC-S/S	78324	105.2
1800	MHS-1800BTV-2SAC-S/S	78325	120.7
1950	MHS-1950BTV-2SAC-S/S	78649	126.0
2100	MHS-2100BTV-2SAC-S/S	78326	131.4
2400	MHS-2400BTV-2SAC-S/S	78327	142.0
3000	MHS-3000BTV-2SAC-S/S	78328	165.0

*NOTE: V-Tips can be used ONLY on vulcanised belts.

Replacement Tips

ORDERING NUMBER	ITEM CODE	WT. KG.
RSA150 (V-Tip)	73628	0.4

Tips Required Per Cleaner Size

BELT WIDTH mm	BLADE COVERAGE mm	V-TIPS REQUIRED
600	600	4
750	750	5
900	900	6
1050	1050	7
1200	1200	8
1350	1350	9
1500	1500	10
1800	1800	12
2100	2100	14
2400	2400	16
3000	3000	20

Product Notes:

- Patent-pending Service Advantage Cartridge™ allows for easy removal in even the dirtiest conditions.
- Heavy-duty design to deliver maximum cleaning efficiency on the most demanding, abusive beltlines.
- Pole Length: Belt width plus 1350mm (single cartridge cleaners); Belt width plus 1500 mm (dual cartridge cleaners).
- Patented PowerFlex™ cushion design to maintain continuous blade-to-belt contact and quick relief from passing mechanical splices.
- C-Tips are for mechanically fastened or vulcanised belts. V-Tips are for vulcanised belts only.
- Visual Blade Tension Check: Measure the tension spring and refer to Spring Length Chart on mounting base for the correct length for best cleaning performance.
- Tensioner mounting brackets included for fast and easy installation.
- Cartridge Removal Kit included for easy removal of the cartridge.

U.S. Patent Pending

Stock items (non-shaded) refer to (*) for specific lead time, if not specified, standard lead time applies.

Non-stock items (shaded) please contact Flexco for dispatch options and lead times.

Product Ordering Information

MHS SAC BT HD® Secondary Cleaner with Service Advantage Cartridge™ & Bolt Tensioner

MHS SAC Cartridge Kits with V-Tips*

BELT WIDTH mm	ORDERING NUMBER	ITEM CODE	WT. KG.
600	MHS-CARK-V24/600	77937	13.3
750	MHS-CARK-V30/750	77938	15.9
900	MHS-CARK-V36/900	77939	18.5
1050	MHS-CARK-V42/1050	77940	21.1
1200	MHS-CARK-V48/1200	77941	23.7
1350	MHS-CARK-V54/1350	77942	26.3
1500	MHS-CARK-V60/1500	77943	28.9
1800	MHS-CARK-V72/1800	77944	34.2
1500	MHS-CARK2-V60/1500	77950	31.8
1800	MHS-CARK2-V72/1800	77951	37.0
2100	MHS-CARK2-V84/2100	77952	42.2
2400	MHS-CARK2-V96/2400	77953	47.4
3000	MHS-CARK2-V120/3000	77954	57.9

*NOTE: V-Tips can be used ONLY on vulcanised belts.

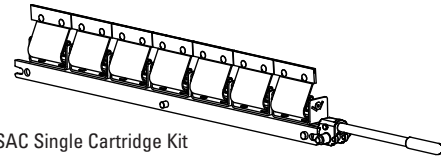

MHS SAC Single Cartridge Kit

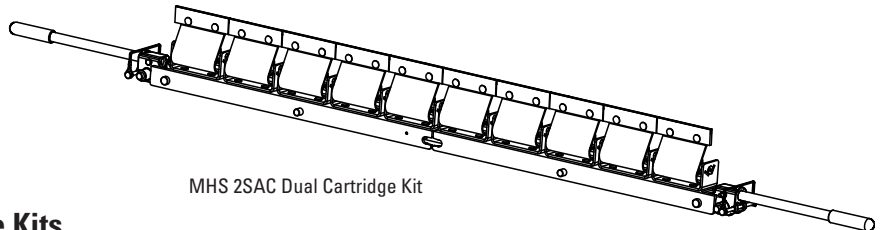

MHS 2SAC Dual Cartridge Kit

MHS SAC Stainless Steel Cartridge Kits with V-Tips*

BELT WIDTH mm	ORDERING NUMBER	ITEM CODE	WT. KG.
600	MHS-CARK-V24/600-S/S MVECKS/S	82841	13.3
750	MHS-CARK-V30/750-S/S MVECKS/S	82842	15.9
900	MHS-CARK-V36/900-S/S MVECKS/S	82843	18.5
1050	MHS-CARK-V42/1050-S/S MVECKS/S	82844	21.1
1200	MHS-CARK-V48/1200-S/S MVECKS/S	82845	23.7
1350	MHS-CARK-V54/1350-S/S MVECKS/S	82846	26.3
1500	MHS-CARK-V60/1500-S/S MVECKS/S	82847	28.9
1800	MHS-CARK-V72/1800-S/S MVECKS/S	82848	34.2
1500	MHS-CARK2-V60/1500-S/S MV2CKSS	82849	31.8
1800	MHS-CARK2-V72/1800-S/S MV2CKSS	82850	37.0
2100	MHS-CARK2-V84/2100-S/S MV2CKSS	82851	42.2
2400	MHS-CARK2-V96/2400-S/S MV2CKSS	82852	47.4
3000	MHS-CARK2-V120/3000-S/S MV2CKS	82853	57.9

*NOTE: V-Tips can be used ONLY on vulcanised belts.

Stock items (non-shaded) refer to (*) for specific lead time, if not specified, standard lead time applies.

Non-stock items (shaded) please contact Flexco for dispatch options and lead times.

Replacement Parts List

MHS SAC BT (Mild Steel) HD® Secondary Cleaner with Service Advantage Cartridge™ & Bolt Tensioner

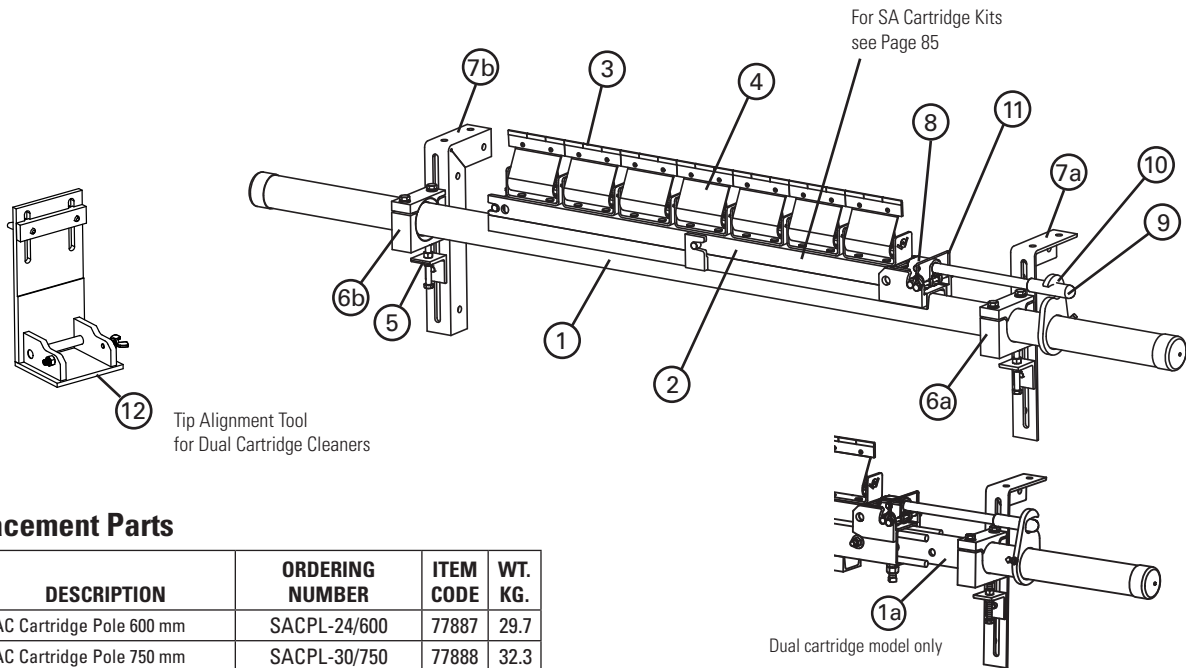

Replacement Parts

REF	DESCRIPTION	ORDERING NUMBER	ITEM CODE	WT. KG.
1	SAC Cartridge Pole 600 mm	SACPL-24/600	77887	29.7
	SAC Cartridge Pole 750 mm	SACPL-30/750	77888	32.3
	SAC Cartridge Pole 900 mm	SACPL-36/900	77889	35.0
	SAC Cartridge Pole 1050 mm	SACPL-42/1050	77890	37.6
	SAC Cartridge Pole 1200 mm	SACPL-48/1200	77891	40.3
	SAC Cartridge Pole 1350 mm	SACPL-54/1350	77892	42.9
	SAC Cartridge Pole 1500 mm	SACPL-60/1500	77893	45.6
	SAC Cartridge Pole 1800 mm	SACPL-72/1800	77894	50.9
	SAC Cartridge Center Pole 1500 mm (Dual)	SACPL2-60/1500	77895	35.1
	SAC Cartridge Center Pole 1800 mm (Dual)	SACPL2-72/1800	77896	40.6
	SAC Cartridge Center Pole 2100 mm (Dual)	SACPL2-84/2100	77897	46.2
	SAC Cartridge Center Pole 2400 mm (Dual)	SACPL2-96/2400	77898	51.8
	SAC Cartridge Center Pole 3000 mm (Dual)	SACPL2-120/3000	77899	64.5
1a	Extender Pole (for use with Dual Cartridge Center Pole)	MHP-EP	76392	24.5
2	SAC Repl Cartridge S/S 600 mm	CART-24/600-S/S	78576	4.5
	SAC Repl Cartridge S/S 750 mm	CART-30/750-S/S	78577	5.6
	SAC Repl Cartridge S/S 900 mm	CART-36/900-S/S	78578	6.7
	SAC Repl Cartridge S/S 1050 mm	CART-42/1050-S/S	78579	7.8
	SAC Repl Cartridge S/S 1200 mm	CART-48/1200-S/S	78580	8.9
	SAC Repl Cartridge S/S 1350 mm	CART-54/1350-S/S	78581	10.0
	SAC Repl Cartridge S/S 1500 mm	CART-60/1500-S/S	78582	11.3
	SAC Repl Cartridge S/S 1800 mm	CART-72/1800-S/S	78583	13.5
	SAC Repl Cartridge S/S 1500 mm (Dual)	CART2-60/1500-S/S	78584	11.2
	SAC Repl Cartridge S/S 1800 mm (Dual)	CART2-72/1800-S/S	78585	13.4
	SAC Repl Cartridge S/S 1950 mm (Dual)	CART2-78/1950-S/S	78635	14.5
	SAC Repl Cartridge S/S 2100 mm (Dual)	CART2-84/2100-S/S	78586	15.6
	SAC Repl Cartridge S/S 2400 mm (Dual)	CART2-96/2400-S/S	78587	17.8
	SAC Repl Cartridge S/S 3000 mm (Dual)	CART2-120/3000-S/S	78588	22.6

REF	DESCRIPTION	ORDERING NUMBER	ITEM CODE	WT. KG.
3	V-Tip* (for vulcanised belts only)	RSA150	73628	0.4
4	PowerFlex™ Cushion*	SPFC	79200	0.9
5	P/R Adjusting Bracket	PAB	75513	0.4
6a	Cradle Clamp Block RH	SMR-CCB-R73	A2843	1.2
6b	Cradle Clamp Block LH	SMR-CCB-L73	A2842	1.2
7a	Mounting Bracket Kit RH	PMBR	75519	3.8
7b	Mounting Bracket Kit LH	PMBL	75516	3.8
8	SAC Removal Knuckle	SACRKN	77882	1.5
9	SAC Removal Handle	SACRH	77883	1.4
10	SAC Handle Lock Plate	SACRHL	77884	0.8
11	Knuckle Retainer Pin	SACKRP	77885	0.1
-	SAC Removal Kit (incl. 1 ea. items 8,9,10,11)	SACRKT	77886	4.1
12	SAC Cartridge Tip Alignment Tool (Dual)	SAC2-TIP-TL	77866	1.1
-	Cradle Clamp Heavy-Duty Mounting Kit (incl. 2 ea. items 5, 7; 1 ea. items 6a, 6b)	CRHMK	62400	10.8

Stock items (non-shaded) refer to (*) for specific lead time, if not specified, standard lead time applies.

Non-stock items (shaded) please contact Flexco for dispatch options and lead times.

Replacement Parts List

MHS SAC BT (Stainless Steel) HD[®] Secondary Cleaner with Service Advantage Cartridge™ & Bolt Tensioner

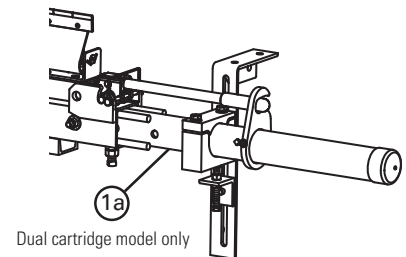
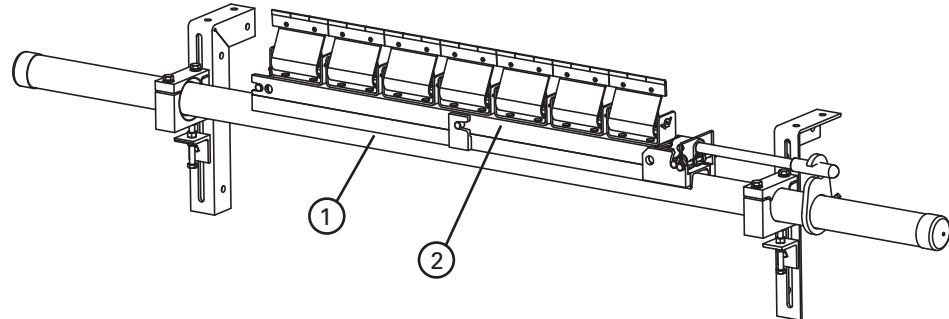

Replacement Parts

REF	DESCRIPTION	ORDERING NUMBER	ITEM CODE	WT. KG.
1	SAC S/S Cartridge Pole 600 mm	SACPL-24/600-S/S	78371	29.7
	SAC S/S Cartridge Pole 750 mm	SACPL-30/750-S/S	78372	32.3
	SAC S/S Cartridge Pole 900 mm	SACPL-36/900-S/S	78373	35.0
	SAC S/S Cartridge Pole 1050 mm	SACPL-42/1050-S/S	78374	37.6
	SAC S/S Cartridge Pole 1200 mm	SACPL-48/1200-S/S	78375	40.3
	SAC S/S Cartridge Pole 1350 mm	SACPL-54/1350-S/S	78376	42.9
	SAC S/S Cartridge Pole 1500 mm	SACPL-60/1500-S/S	78377	45.6
	SAC S/S Cartridge Pole 1800 mm	SACPL-72/1800-S/S	78378	50.9
	SAC S/S Cartridge Center Pole 1500 mm (Dual)	SACPL2-60/1500-S/S	78379	35.1
	SAC S/S Cartridge Center Pole 1800 mm (Dual)	SACPL2-72/1800-S/S	78380	40.6
	SAC S/S Cartridge Center Pole 1950 mm (Dual)	SACPL2-78/1950-S/S	78642	43.9
	SAC S/S Cartridge Center Pole 2100 mm (Dual)	SACPL2-84/2100-S/S	78381	46.2
	SAC S/S Cartridge Center Pole 2400 mm (Dual)	SACPL2-96/2400-S/S	78382	51.8
	SAC S/S Cartridge Center Pole 3000 mm (Dual)	SACPL2-120/3000-S/S	78383	64.5
1a	S/S Extender Pole (for use with S/S Dual Cartridge Center Pole)	MHP-EP-S/S	77599	24.5
2	SAC Repl Cartridge S/S 600 mm	CART-24/600-S/S	78576	4.5
	SAC Repl Cartridge S/S 750 mm	CART-30/750-S/S	78577	5.6
	SAC Repl Cartridge S/S 900 mm	CART-36/900-S/S	78578	6.7
	SAC Repl Cartridge S/S 1050 mm	CART-42/1050-S/S	78579	7.8
	SAC Repl Cartridge S/S 1200 mm	CART-48/1200-S/S	78580	8.9
	SAC Repl Cartridge S/S 1350 mm	CART-54/1350-S/S	78581	10.0
	SAC Repl Cartridge S/S 1500 mm	CART-60/1500-S/S	78582	11.3
	SAC Repl Cartridge S/S 1800 mm	CART-72/1800-S/S	78583	13.5

Stock items (non-shaded) refer to (*) for specific lead time, if not specified, standard lead time applies.

Non-stock items (shaded) please contact Flexco for dispatch options and lead times.

Replacement Parts List

MHS SAC BT (Stainless Steel) HD[®] Secondary Cleaner with Service Advantage Cartridge™ & Bolt Tensioner

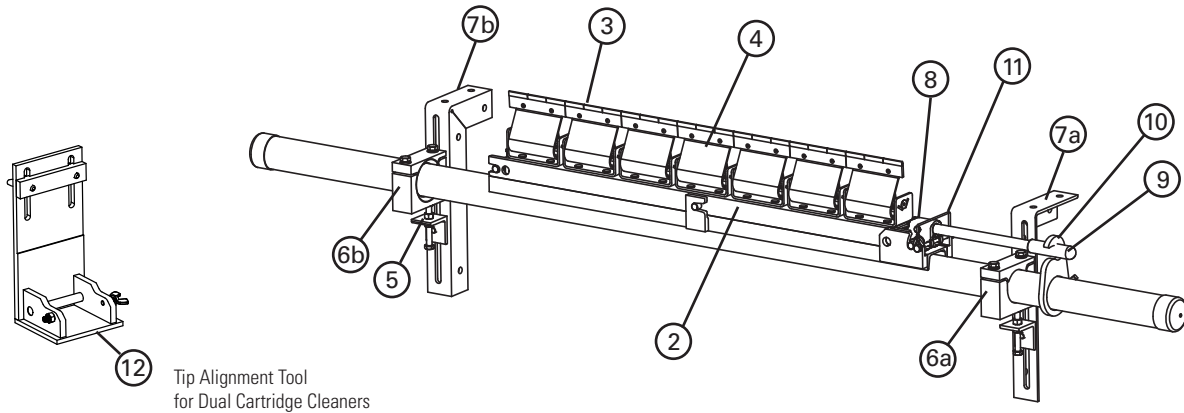

Tip Alignment Tool
for Dual Cartridge Cleaners

Replacement Parts (Continued)

REF	DESCRIPTION	ORDERING NUMBER	ITEM CODE	WT. KG.
2	SAC Repl Cartridge S/S 1500 mm (Dual)	CART2-60/1500-S/S	78584	11.2
	SAC Repl Cartridge S/S 1800 mm (Dual)	CART2-72/1800-S/S	78585	13.4
	SAC Repl Cartridge S/S 1950 mm (Dual)	CART2-78/1950-S/S	78635	14.5
	SAC Repl Cartridge S/S 2100 mm (Dual)	CART2-84/2100-S/S	78586	15.6
	SAC Repl Cartridge S/S 2400 mm (Dual)	CART2-96/2400-S/S	78587	17.8
	SAC Repl Cartridge S/S 3000 mm (Dual)	CART2-120/3000-S/S	78588	22.6
3	S/S V-Tip* (for vulcanised belts only)	RVT6-S/S	76205	0.4
4	PowerFlex™ Cushion S/S*	SPFC-S/S	79201	0.9
5	P/R Adjusting Bracket S/S	PAB-S/S	75515	0.4
6a	Cradle Clamp Block RH S/S	CRDLBLK-RH-S/S	A2825	1.2
6b	Cradle Clamp Block LH S/S	CRDLBLK-LH-S/S	A2826	1.2
7a	Mounting Bracket Kit RH S/S	PMBR-S/S	75521	3.8
7b	Mounting Bracket Kit LH S/S	PMBL-S/S	75518	3.8
8	SAC Removal Knuckle	SACRKN	77882	1.5
9	SAC Removal Handle S/S	SACRH-S/S	78397	1.4
10	SAC Handle Lock Plate S/S	SACRHL-S/S	78398	0.8
11	Knuckle Retainer Pin S/S	SACKRP-S/S	78399	0.1
-	SAC Removal Kit S/S (includes 1 ea. items 8,9,10,11)	SACRKT-S/S	78401	4.1
12	SAC Cartridge Tip Alignment Tool (Dual)	SAC2-TIP-TL	77866	1.1
-	Cradle Clamp Stainless Steel Heavy-Duty Mounting Kit (incl. 2 ea. item 5; incl. 1 ea. items 6a, 6b, 7a, 7b)	CRHMK-S/S	62095	10.8

Stock items (non-shaded) refer to (*) for specific lead time, if not specified, standard lead time applies.

Non-stock items (shaded) please contact Flexco for dispatch options and lead times.

Specifications & Guidelines

MHS SAC BT HD® Secondary Cleaner with Service Advantage Cartridge™ & Bolt Tensioner

Pole Length Specifications*

VERSION	CLEANER SIZE mm	BLADE WIDTH mm	POLE LENGTH mm	MAXIMUM CONVEYOR SPAN mm
Single	600	600	1950	1650
	750	750	2100	1800
	900	900	2250	1950
	1050	1050	2400	2100
	1200	1200	2550	2250
	1350	1350	2700	2400
	1500	1500	2850	2550
Dual	1800	1800	3150	2850
	1500	1500	3000	2700
	1800	1800	3300	3000
	2100	2100	3600	3300
	2400	2400	3900	3600
	3000	3000	4500	4200

*For special extra long pole length requirements a Pole Extender Kit (#76024) is available that provides 750 mm of extended pole length.
Pole Diameter - 73 mm

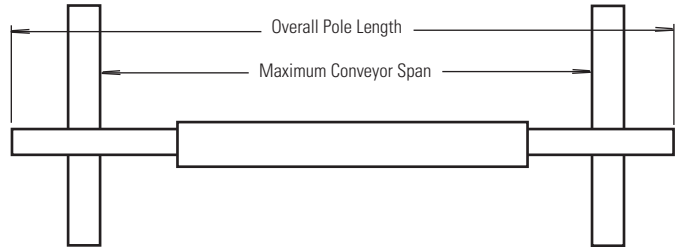

Clearance Guidelines for Installation

VERSION	HORIZONTAL CLEARANCE REQUIRED mm	VERTICAL CLEARANCE REQUIRED mm
Single	114	279
Dual	114	318

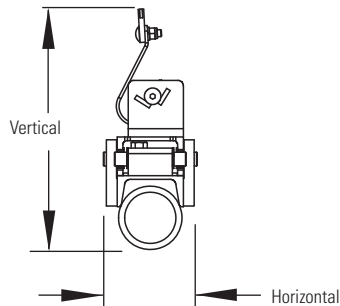

Specifications:

- Maximum Belt Speed5M/sec
- Temperature Rating-35°C to 82°C
- Usable Blade Wear Length.....9 mm
- Blade MaterialsC-Tip: Impact Resistant Tungsten Carbide (works with mechanical fasteners)
V-Tip: Long Life Tungsten Carbide (for vulcanised belts only)
- Available for Belt Widths600 to 3000 mm. Other sizes available upon request.

U.S. Patent Pending

Product Ordering Information

Spring Covers and Tensioner Lock

Spring Covers

ORDERING NUMBER	ITEM CODE	WT. KG.
SPG-CVR-A	77387	0.14
SPG-CVR-B	77388	0.14
SPG-CVR-C	77389	0.14
SPG-CVR-D	77390	0.18
SPG-CVR-E	77391	0.18
SPG-CVR-F	77392	0.14
SPG-CVR-G	77393	0.14
SPG-CVR-H	77741	0.14

Includes 1 spring cover

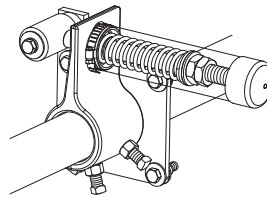
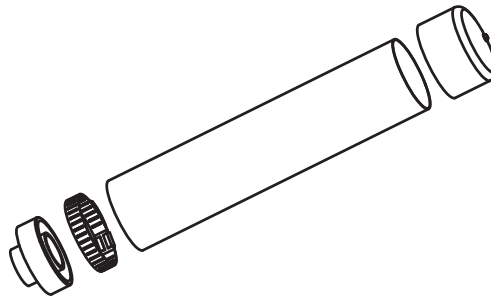

Spring cover on Primary Cleaner tensioner

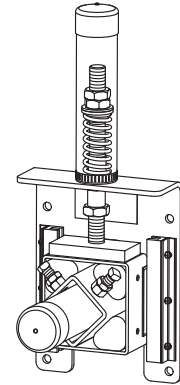

Spring cover on Secondary cleaner tensioner

Tensioner Lock

Designed to prevent tampering or unauthorized retensioning of the cleaner.

ORDERING NUMBER	ITEM CODE	WT. KG.
TEN-LOCK-KIT	77443	0.18

*For MSP, MMP, MHP, MHCP, H-Type® Primary Cleaners and MSS, MHS, MDWS Secondary Cleaners

Includes 1 tensioner lock

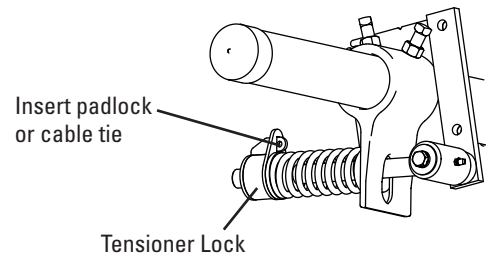
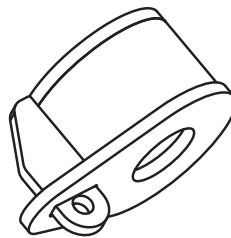

Tensioner Lock

(Primary Cleaner tensioner shown)

 **Stock items** (non-shaded) refer to (*) for specific lead time, if not specified, standard lead time applies.

 **Non-stock items** (shaded) please contact Flexco for dispatch options and lead times.

Patent pending

Product Ordering Information

U-Type® Secondary Cleaner with USTensioner



U-Type® with V-Blade (Tungsten Carbide)* and USTensioner, Mild Steel

CLEANER COMPLETE				REPLACEMENT V-BLADE		
BELT WIDTH mm	ORDERING NUMBER	ITEM CODE	WT. KG.	ORDERING NUMBER	ITEM CODE	WT. KG.
450	UTV450	77297	38.4	URVB18/450	76736	2.3
600	UTV600	77298	41.3	URVB24/600	76737	3.1
750	UTV750	77299	43.9	URVB30/750	76738	3.8
900	UTV900	77300	46.6	URVB36/900	76739	4.6
1050	UTV1050	77301	49.1	URVB42/1050	76740	5.3
1200	UTV1200	77302	51.9	URVB48/1200	76741	5.7
1350	UTV1350	77303	54.3	URVB54/1350	76742	6.8
1400	UTV1400	77304	55.1	URVB56/1400	77314	7.1
1500	UTV1500	77305	57.0	URVB60/1500	76743	7.6
1600	UTV1600	77306	59.0	URVB64/1600	77315	8.1
1800	UTV1800	77307	71.6	URVB72/1800	76744	9.2
2000	UTV2000	77308	75.3	URVB80/2000	77320	10.2
2100	UTV2100	77309	78.4	URVB84/2100	76745	10.7
2200	UTV2200	77310	81.7	URVB88/2200	77316	11.2
2400	UTV2400	77411	84.6	URVB94/2400	77421	12.0
2500	UTV2500	77412	87.1	URVB98/2500	77422	12.5

*NOTE: V-Blades (Tungsten Carbide) can be used on vulcanised belts and mechanically spliced belts ONLY IF the splice is skived (recessed into the belt's cover) (on solid plate splices the bolts must be ground).

CAUTION: The V-Blade CANNOT be used on belts with mechanical rip repair fasteners.

U-Type® with V-Blade (Tungsten Carbide)* and USTensioner, Stainless Steel

CLEANER COMPLETE				REPLACEMENT V-BLADE		
BELT WIDTH mm	ORDERING NUMBER	ITEM CODE	WT. KG.	ORDERING NUMBER	ITEM CODE	WT. KG.
450	UTV450-S/S	82707	17.0	URVB18/450	76736	2.3
600	UTV600-S/S	82708	18.2	URVB24/600	76737	3.1
750	UTV750-S/S	82709	19.6	URVB30/750	76738	3.8
900	UTV900-S/S	82710	21.7	URVB36/900	76739	4.6
1050	UTV1050-S/S	82711	23.1	URVB42/1050	76740	5.3
1200	UTV1200-S/S	82712	26.0	URVB48/1200	76741	5.7
1350	UTV1350-S/S	82713	27.7	URVB54/1350	76742	6.8
1400	UTV1400-S/S	82714	28.7	URVB56/1400	77314	7.1
1500	UTV1500-S/S	82715	31.0	URVB60/1500	76743	7.6
1600	UTV1600-S/S	82716	32.9	URVB64/1600	77315	8.1
1800	UTV1800-S/S	82717	36.4	URVB72/1800	76744	9.2
2000	UTV2000-S/S	82718	39.0	URVB80/2000	77320	10.2
2100	UTV2100-S/S	82719	41.7	URVB84/2100	76745	10.7
2200	UTV2200-S/S	82720	44.4	URVB88/2200	77316	11.2
2400	UTV2400-S/S	82721	47.1	URVB94/2400	77421	12.0
2500	UTV2500-S/S	82722	49.8	URVB98/2500	77422	12.5

*NOTE: V-Blades (Tungsten Carbide) can be used on vulcanised belts and mechanically spliced belts ONLY IF the splice is skived (recessed into the belt's cover) (on solid plate splices the bolts must be ground).

CAUTION: The V-Blade CANNOT be used on belts with mechanical rip repair fasteners.

Stock items (non-shaded) refer to (*) for specific lead time, if not specified, standard lead time applies.

Non-stock items (shaded) please contact Flexco for dispatch options and lead times.

Product Ordering Information

U-Type® Secondary Cleaner with J-Bolt Tensioner

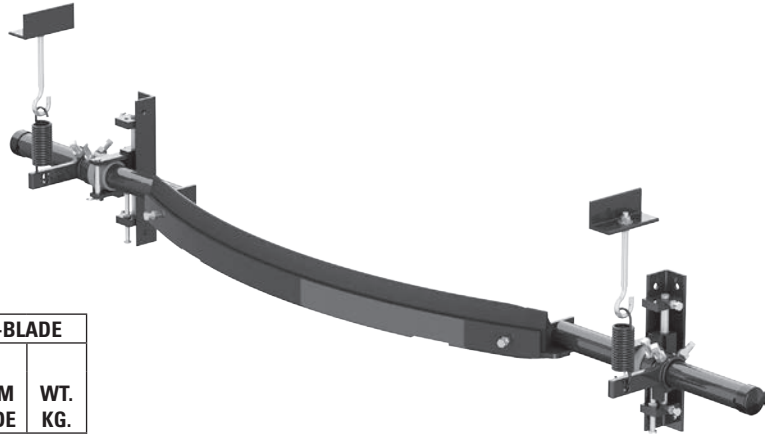

U-Type® with V-Blade (Tungsten Carbide)* and J-Bolt Tensioner, Mild Steel

CLEANER COMPLETE				REPLACEMENT V-BLADE		
BELT WIDTH mm	ORDERING NUMBER	ITEM CODE	WT. KG.	ORDERING NUMBER	ITEM CODE	WT. KG.
450	UTV450-J	77283	37.3	URVB18/450	76736	2.3
600	UTV600-J	77284	40.0	URVB24/600	76737	3.1
750	UTV750-J	77285	43.2	URVB30/750	76738	3.8
900	UTV900-J	77286	47.7	URVB36/900	76739	4.6
1050	UTV1050-J	77287	50.9	URVB42/1050	76740	5.3
1200	UTV1200-J	77288	57.3	URVB48/1200	76741	5.7
1350	UTV1350-J	77289	60.9	URVB54/1350	76742	6.8
1400	UTV1400-J	77290	63.2	URVB56/1400	77314	7.1
1500	UTV1500-J	77291	68.2	URVB60/1500	76743	7.6
1600	UTV1600-J	77292	72.3	URVB64/1600	77315	8.1
1800	UTV1800-J	77293	80.0	URVB72/1800	76744	9.2
2000	UTV2000-J	77294	85.9	URVB80/2000	77320	10.2
2100	UTV2100-J	77295	91.8	URVB84/2100	76745	10.7
2200	UTV2200-J	77296	97.7	URVB88/2200	77316	11.2
2400	UTV2400-J	77413	103.6	URVB94/2400	77421	12.0
2500	UTV2500-J	77414	109.6	URVB98/2500	77422	12.5

*NOTE: V-Blades (Tungsten Carbide) can be used on vulcanised belts and mechanically spliced belts ONLY IF the splice is skived (recessed into the belt's cover) (on solid plate splices the bolts must be ground).

CAUTION: The V-Blade CANNOT be used on belts with mechanical rip repair fasteners.

U-Type® with V-Blade (Tungsten Carbide)* and J-Bolt Tensioner, Stainless Steel

CLEANER COMPLETE				REPLACEMENT V-BLADE		
BELT WIDTH MM	ORDERING NUMBER	ITEM CODE	WT. KG.	ORDERING NUMBER	ITEM CODE	WT. KG.
450	UTV450J-S/S	77259	37.3	URVB18/450	76736	2.3
600	UTV600J-S/S	77260	40.0	URVB24/600	76737	3.1
750	UTV750J-S/S	77261	43.2	URVB30/750	76738	3.8
900	UTV900J-S/S	77262	47.7	URVB36/900	76739	4.6
1050	UTV1050J-S/S	77263	50.9	URVB42/1050	76740	5.3
1200	UTV1200J-S/S	77264	57.3	URVB48/1200	76741	5.7
1350	UTV1350J-S/S	77265	60.9	URVB54/1350	76742	6.8
1400	UTV1400J-S/S	77266	63.2	URVB56/1400	77314	7.1
1500	UTV1500J-S/S	77267	68.2	URVB60/1500	76743	7.6
1600	UTV1600J-S/S	77268	72.3	URVB64/1600	77315	8.1
1800	UTV1800J-S/S	77269	80.0	URVB72/1800	76744	9.2
2000	UTV2000J-S/S	77270	85.9	URVB80/2000	77320	10.2
2100	UTV2100J-S/S	77271	91.8	URVB84/2100	76745	10.7
2200	UTV2200J-S/S	77272	97.7	URVB88/2200	77316	11.2
2400	UTV2400J-S/S	77417	103.6	URVB94/2400	77421	12.0
2500	UTV2500J-S/S	77418	109.6	URVB98/2500	77422	12.5

*NOTE: V-Blades (Tungsten Carbide) can be used on vulcanised belts and mechanically spliced belts ONLY IF the splice is skived (recessed into the belt's cover) (on solid plate splices the bolts must be ground).

CAUTION: The V-Blade CANNOT be used on belts with mechanical rip repair fasteners.

Stainless Steel U-Type with C or F blade available by special order

Stock items (non-shaded) refer to (*) for specific lead time, if not specified, standard lead time applies.

Non-stock items (shaded) please contact Flexco for dispatch options and lead times.

Replacement Parts List

U-Type[®] Secondary Cleaner with UST Tensioner or J-Bolt Tensioner

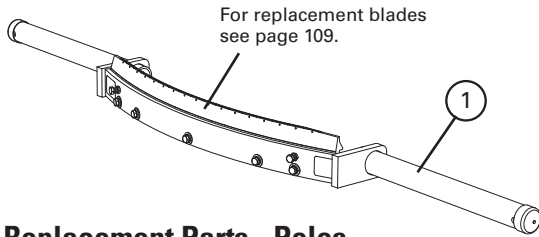

Replacement Parts - Poles

REF	DESCRIPTION	ORDERING NUMBER	ITEM CODE	WT. KG.
1	450mm Pole	USP18/450	82689	18.6
	600mm Pole	USP24/600	82690	20.1
	750mm Pole	USP30/750	82691	21.6
	900mm Pole	USP36/900	82692	23.2
	1050mm Pole	USP42/1050	82693	24.8
	1200mm Pole	USP48/1200	82694	26.3
	1350mm Pole	USP54/1350	82695	27.9
	1400mm Pole	USP56/1400	82696	28.4
	1500mm Pole	USP60/1500	82697	29.5
	1600mm Pole	USP64/1600	82698	30.5
	1800mm Pole	USP72/1800	82699	32.6
	2000mm Pole	USP80/2000	82700	34.6
	2100mm Pole	USP84/2100	82701	35.7
	2200mm Pole	USP88/2200	82702	36.7
	2400mm Pole	USP94/2400	82703	38.3
2500mm Pole	USP98/2500	82704	39.4	

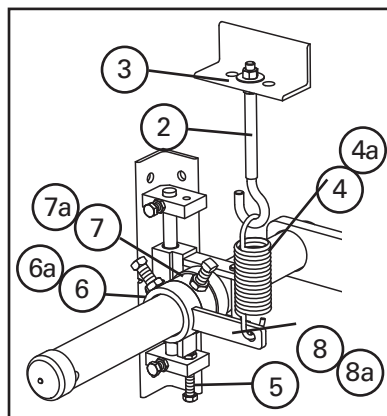

For use in changing UST Spring Tensioner to a J-Bolt Tensioner

Replacement Parts - J-bolt Tensioner

REF	DESCRIPTION	ORDERING NUMBER	ITEM CODE	WT. KG.
2	J-Bolt Kit* (incl. locknut and washer)	STJK-S/S	74417	0.3
3	J-Bolt Mount (1 ea.)	STJM	74775	1.4
4	450-1500mm Tension Spring (1 ea.)	STTS	74419	0.5
4a	1600 mm+ Tension Spring (1 ea.)	HDTs	74502	0.7
5	Adjusting Bolt Kit (incl. locknut)	ABU	76788	0.5
6	450-1500 mm UHMW Bearing (1 ea.)	USPB	76786	0.5
6a	1600 mm+ UHMW Bearing (1 ea.)	UHPB	76787	0.5
7	450-1500 mm Stop Collar* (1 ea.)	SCU60	82812	0.9
7a	1600 mm+ Stop Collar* (1 ea.)	SCUHD	82813	0.9
8	450-1500 mm Adjusting Arm* (1 ea.)	HARK	73069	0.9
8a	1600mm+ Adjusting Arm* (1 ea.)	HDARK	77329	0.9
-	450-1500 mm Mounting Kit* (incl. 2 of items 2, 3, 4, 5, 6, 7, 8, 9 & incl. 1 of Item 5)	MMKU	77324	18.2
-	1600 mm+ Mounting Kit* (incl. 2 of items 2, 3, 4a, 6, 7a, 8a, 9a & incl 1 of item 5)	MMKUHD	77327	19.6

*Hardware included

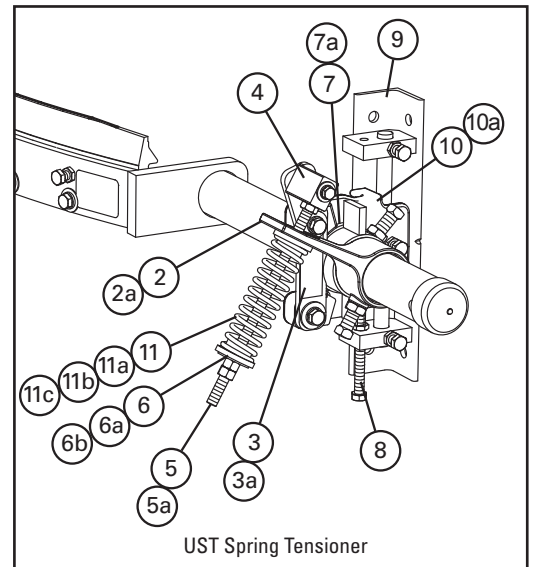

UST Spring Tensioner

Replacement Parts - UST Tensioner

REF	DESCRIPTION	ORDERING NUMBER	ITEM CODE	WT. KG.
2	Torque Arm Kit (1 ea.)	ESTAK	76406	1.6
2A	Torque Arm Kit HD (1 ea.)	C-PSTA	81045	5.2
3	Pivot Shaft Bracket Kit (1 ea.)	MUPSBK	82896	0.8
3A	Pivot Shaft Bracket Kit HD (1 ea.)	QMTPSBK-CN	82182	2.0
4	Pivot Block Kit (1 ea.)	MESPBL	87895	0.5
5	Pivot Rod Kit (1 ea.)	MESPKR	81896	0.5
5A	Pivot Rod Kit HD (1 ea.)	PTPK-MT	82343	2.0
6	EST Bush Kit P&S MET	MESBK-PS	82364	0.05
6A	QMT Bush Kit W&S MET	QMTBK-WS-MT	82175	0.05
6B	QMT Bush Kit G MET	QMTBK-GCN	82174	0.05
7	Standard Pole Bearing (1 ea.)	USPB2	79206	0.05
7A	HD Pole Bearing (1 ea.)	UHPB2	79207	0.1
8	Adjusting Bolt Kit (1 ea. incl. lock nut)	ABU	76788	0.1
9	Mounting Bracket Kit (1 ea. incl. L & R)	UMBK-M	82890	4.4
10	Slide Plate Kit (1 ea.)	USPK	76790	2.1
10A	HD Slide Plate Kit (1 ea.)	UHSPK-M	82887	2.4
11	Tension Spring Purple (1 ea.)	QMTS-P	75845	0.3
11A	Tension Spring Silver (1 ea.)	ESS-S	76412	0.5
11B	Tension Spring White (1 ea.)	PSTS-W	75898	0.8
11C	Tension Spring Gold (1 ea.)	QMT-G	76484	0.8
-	UST Spring Tensioner Mounting Kit* - Purple (Incl. 1 ea. Items 2, 3, 4, 5, 6, 8, 9, 10 & 11)	UST-P-MT	82897	9.5
-	UST Spring Tensioner Mounting Kit* - Silver (Incl. 1 ea. Items 2A, 4, 5A, 6A, 8, 9, 10A & 11A)	UST-S-MT	82898	13.1
-	Heavy-Duty UST Spring Tensioner* - White (Incl. 1 ea. Items 2A, 4, 5A, 6A, 8, 9, 10A & 11B)	UST-W-MT	82899	16.7
-	Heavy-Duty UST Spring Tensioner* - Gold (Incl. 1 ea. Items 2A, 4, 5A, 6A, 8, 9, 10A & 11C)	UST-G-MT	82900	16.7

*Hardware included

Stock items (non-shaded) refer to (*) for specific lead time, if not specified, standard lead time applies.

Non-stock items (shaded) please contact Flexco for dispatch options and lead times.

Replacement Parts List

Stainless Steel U-Type[®] Secondary Cleaner with UST Tensioner or J-Bolt Tensioner

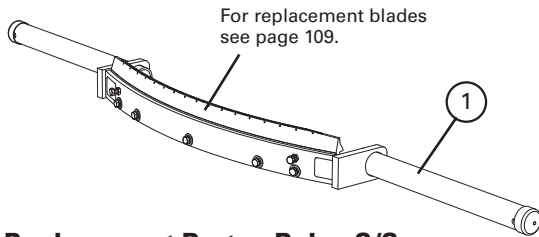

Replacement Parts - Poles S/S

REF	DESCRIPTION	ORDERING NUMBER	ITEM CODE	WT. KG.
1	450mm Pole	USP18/450-S/S	77339	18.6
	600mm Pole	USP24/600-S/S	77340	20.1
	750mm Pole	USP30/750-S/S	77341	21.6
	900mm Pole	USP36/900-S/S	77342	23.2
	1050mm Pole	USP42/1050-S/S	77343	24.8
	1200mm Pole	USP48/1200-S/S	77344	26.3
	1350mm Pole	USP54/1350-S/S	77345	27.9
	1400mm Pole	USP56/1400-S/S	77346	28.4
	1500mm Pole	USP60/1500-S/S	77347	29.5
	1600mm Pole	USP64/1600-S/S	77348	30.5
	1800mm Pole	USP72/1800-S/S	77349	32.6
	2000mm Pole	USP80/2000-S/S	77350	34.6
	2100mm Pole	USP84/2100-S/S	77351	35.7
	2200mm Pole	USP88/2200-S/S	77352	36.7
	2400mm Pole	USP94/2400-S/S	77419	38.3
2500mm Pole	USP98/2500-S/S	77418	39.4	

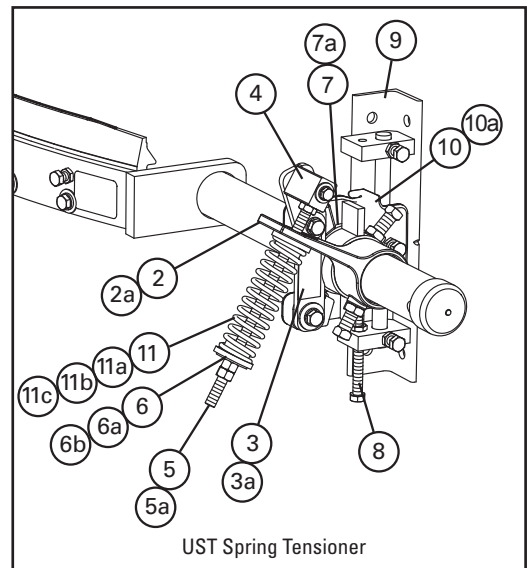

UST Spring Tensioner

Replacement Parts - UST Tensioner S/S

REF	DESCRIPTION	ORDERING NUMBER	ITEM CODE	WT. KG.
2	Torque Arm Kit (1 ea.)	ESTAK-SS	78849	1.6
2A	Torque Arm Kit HD (1 ea.)	MPSTA-S/S	82289	5.2
3	Pivot Shaft Bracket Kit (1 ea.)	MUPSBK-SS	82893	0.8
3A	Pivot Shaft Bracket Kit HD (1 ea.)	MQMTSBK-SS	82895	2.0
4	Pivot Block Kit (1 ea.)	MESPBL-SS	82892	0.5
5	Pivot Rod Kit (1 ea.)	MESPKR-SS	82894	0.5
5A	Pivot Rod Kit HD (1 ea.)	PTPK-MT-S/S	82342	2.0
6	EST Bush Kit P&S MET	MESBK-PS	82364	0.05
6A	QMT Bush Kit W&S MET	QMTBK-WS-MT	82175	0.05
6B	QMT Bush Kit G MET	QMTBK-GCN	82174	0.05
7	Standard Pole Bearing (1 ea.)	USPB2	79206	0.05
7A	HD Pole Bearing (1 ea.)	UHPB2	79207	0.1
8	Adjusting Bolt Kit (1 ea. incl. lock nut)	ABU	76788	0.1
9	Mounting Bracket Kit (1 ea. incl. L & R)	UMBK-SS-M	82891	4.4
10	Slide Plate Kit (1 ea.)	USPK-SS-M	82888	2.1
10A	HD Slide Plate Kit (1 ea.)	UHSPK-SS-M	82889	2.4
11	Tension Spring Purple (1 ea.)	QMTS-P-SS	77450	0.3
11A	Tension Spring Silver (1 ea.)	ESS-S-S/S	79288	0.5
11B	Tension Spring White (1 ea.)	QMTS-W-SS	77451	0.8
11C	Tension Spring Gold (1 ea.)	QMTS-G-SS	77452	0.8
-	UST Spring Tensioner Mounting Kit* - Purple (Incl. 1 ea. Items 2, 3, 4, 5, 6, 8, 9, 10 & 11)	UST-P-MT-SS	82901	9.5
-	UST Spring Tensioner Mounting Kit* - Silver (Incl. 1 ea. Items 2A, 4, 5A, 6A, 8, 9, 10A & 11A)	UST-S-MT-SS	82902	13.1
-	Heavy-Duty UST Spring Tensioner* - White (Incl. 1 ea. Items 2A, 4, 5A, 6A, 8, 9, 10A & 11B)	UST-W-MT-SS	82903	16.7
-	Heavy-Duty UST Spring Tensioner* - Gold (Incl. 1 ea. Items 2A, 4, 5A, 6A, 8, 9, 10A & 11C)	UST-G-MT-SS	82904	16.7

*Hardware included

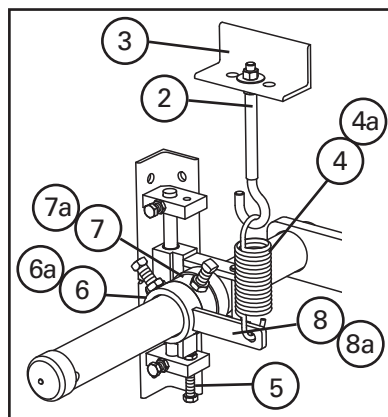

For use in changing UST Spring Tensioner to a J-Bolt Tensioner

Replacement Parts - J-bolt Tensioner S/S

REF	DESCRIPTION	ORDERING NUMBER	ITEM CODE	WT. KG.
2	J-Bolt Kit* (incl. locknut and washer)	STJK-S/S	74417	0.3
3	J-Bolt Mount (1 ea.)	STJM-S/S	77332	1.4
4	450-1500mm Tension Spring (1 ea.)	STTS-S/S	75585	0.5
4a	1600 mm+ Tension Spring (1 ea.)	HDTSS-S/S	75586	0.7
5	Adjusting Bolt Kit (incl. locknut)	ABU	76788	0.5
6	450-1500 mm UHMW Bearing (1 ea.)	USPB	76786	0.5
6a	1600 mm+ UHMW Bearing (1 ea.)	UHPB	76787	0.5
7	450-1500 mm Stop Collar* (1 ea.)	SCU60-S/S	82810	0.9
7a	1600 mm+ Stop Collar* (1 ea.)	SCUHD-S/S	82811	0.9
8	450-1500 mm Adjusting Arm* (1 ea.)	HARK-S/S	77364	0.9
8a	1600mm+ Adjusting Arm* (1 ea.)	HDARK-S/S	77331	0.9
-	450-1500 mm Mounting Kit* (incl. 2 of items 2, 3, 4, 5, 6, 7, 8, 9 & incl. 1 of item 5)	MMKU-SS	77357	18.2
-	1600 mm+ Mounting Kit* (incl. 2 of items 2, 3, 4a, 6, 7a, 8a, 9a & incl 1 of item 5)	MMKUHD-SS	77358	19.6

*Hardware included

Stock items (non-shaded) refer to (*) for specific lead time, if not specified, standard lead time applies.

Non-stock items (shaded) please contact Flexco for dispatch options and lead times.

Replacement Parts List

U-Type® V-Blades (Tungsten Carbide)*

BELT WIDTH mm	ORDERING NUMBER	ITEM CODE	WT. KG.
450	URVB18/450	76736	2.3
600	URVB24/600	76737	3.1
750	URVB30/750	76738	3.8
900	URVB36/900	76739	4.6
1050	URVB42/1050	76740	5.3
1200	URVB48/1200	76741	6.1
1350	URVB54/1350	76742	6.8
1400	URVB56/1400	77314	7.1
1500	URVB60/1500	76743	7.6
1600	URVB64/1600	77315	8.1
1800	URVB72/1800	76744	9.2
2000	URVB80/2000	77320	10.2
2100	URVB84/2100	76745	10.7
2200	URVB88/2200	77316	11.2
2400	URVB94/2400	77421	12.0
2500	URVB98/2500	77422	12.5

*NOTE: V-Blades (Tungsten Carbide) can be used on vulcanised belts. CAUTION: The V-Blade CANNOT be used on belts with mechanical rip repair fasteners. Use the F-Blade. Replacement blades also available in FRAS. Contact Flexco® for more information.

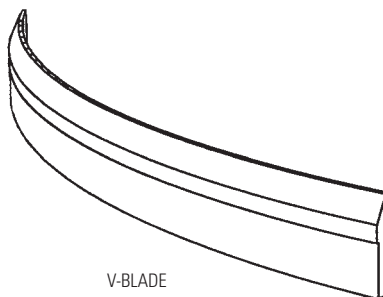

V-BLADE

U-Type® C-Blades (Impact-Resistant Tungsten Carbide)*

BELT WIDTH mm	ORDERING NUMBER	ITEM CODE	WT. KG.
450	URCB18/450	76748	2.3
600	URCB24/600	76749	3.1
750	URCB30/750	76750	3.8
900	URCB36/900	76751	4.6
1050	URCB42/1050	76752	5.3
1200	URCB48/1200	76753	6.1
1350	URCB54/1350	76754	6.8
1400	URCB56/1400	77317	7.1
1500	URCB60/1500	76755	7.6
1600	URCB64/1600	77318	8.1
1800	URCB72/1800	76756	9.2
2000	URCB80/2000	77321	10.2
2100	URCB84/2100	76757	10.7
2200	URCB88/2200	76319	11.2
2400	URCB94/2400	77448	12.0
2500	URCB98/2500	77449	12.5

*NOTE: C-Blades can be used on Flexco Solid Plate, mechanically fastened and vulcanised belts. Replacement blades also available in FRAS. Contact Flexco for more information.

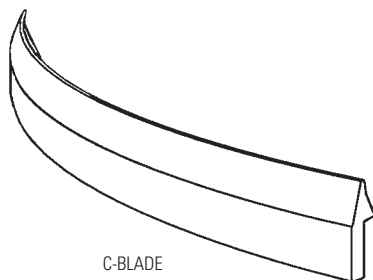

C-BLADE

U-Type® F-Blades (Purple Urethane)*

BELT WIDTH mm	ORDERING NUMBER	ITEM CODE	WT. KG.
450	UFB18	74448	1.4
600	UFB24	74449	1.8
750	UFB30	74450	2.3
900	UFB36	74451	2.7
1050	UFB42	74452	3.2
1200	UFB48	74453	3.6
1350	UFB54	74454	4.1
1500	UFB60	74455	4.6
1800	UFB72	74456	5.5
2100	UFB84	74460	6.4

*NOTE: F-Blades (Urethane) can be used on mechanically fastened belts and vulcanised belts.

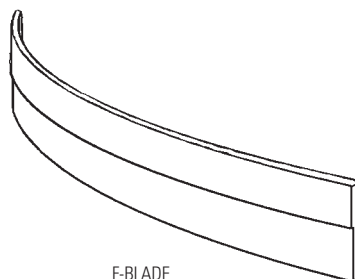

F-BLADE

Stock items (non-shaded) refer to (*) for specific lead time, if not specified, standard lead time applies.
Non-stock items (shaded) please contact Flexco for dispatch options and lead times.

Specifications & Guidelines

U-Type® Secondary Cleaner

Pole Length Specifications

CLEANER SIZE mm	POLE LENGTH mm	MAXIMUM CONVEYOR SPAN mm
450	1375	1125
600	1575	1325
750	1825	1575
900	1975	1925
1050	2125	1875
1200	2375	2125
1350	2525	2275
1500	2650	2400
1800	2950	2700

Pole Diameter - 450-1500 mm cleaners: 60 mm
Pole Diameter - 1600 mm+ cleaners: 75 mm

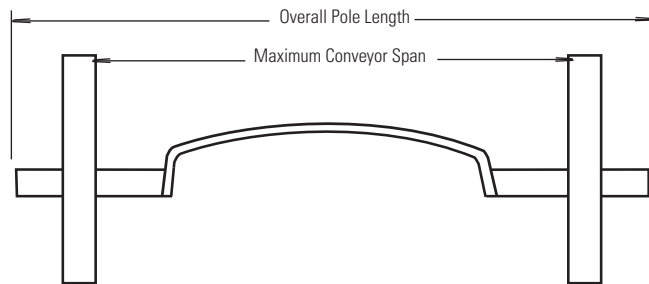

Clearance Guidelines For Installation

BELT WIDTH/ CLEANER SIZE mm	CLEARANCE REQUIRED mm
450	140
600	166
750	191
900	171
1050	217
1200	242
1350	242
1500	242
1800	261
2100	261

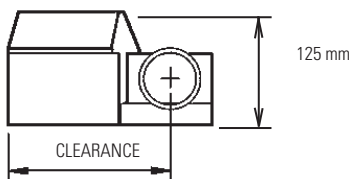

Spring Length Chart

(For Cleaners with UST Tensioners)

BLADE WIDTH mm	PURPLE SPRING mm	SILVER SPRING mm
450	160	N/A
600	156	N/A
750	152	N/A
900	147	N/A
1050	142	N/A
1200	133	N/A
1350	127	N/A
1400	125	N/A
1500	125	N/A
1600	N/A	142
1800	N/A	142
2000	N/A	138
2100	N/A	136
2200	N/A	136
2400	N/A	133
2500	N/A	132

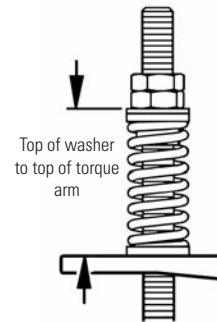

Spring Tensioner Guidelines

(For Cleaners with J-Bolt Tensioners)

- Spring gap = .7 mm minimum
- Gauge provided

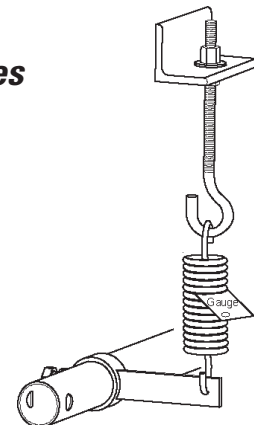

Specifications:

- Maximum Belt SpeedContact Flexco®
- Temperature Rating-35°C to 82°C
- Usable Blade Wear Length.....V-Blade and C-Blade - 9 mm; F-Blade - 44 mm
- Available for Belt Widths450 to 2500 mm.
Other sizes available upon request

Product Ordering Information

Motorised Brush Cleaner

Motorized Brush Cleaner

BELT WIDTH		ORDERING NUMBER	ITEM CODE	WT. KG.
mm	in.			
450	18	MBC-18	79494	62.1
600	24	MBC-24	79495	66.6
750	30	MBC-30	79496	68.3
900	36	MBC-36	79497	71.1
1050	42	MBC-42	79498	73.9
1200	48	MBC-48	79499	81.4
1350	54	MBC-54	79500	84.5
1500	60	MBC-60	79501	87.3
1800	72	MBC-72	79502	93.2
2100	84	MBC-84	79503	98.9



Motorised Brush Cleaner

Replacement Brushes

BELT WIDTH		ORDERING NUMBER	ITEM CODE	WT. LBS.
mm	in.			
450	18	MBRD-18	79514	9.6
600	24	MBRD-24	79515	13.5
750	30	MBRD-30	79516	17.1
900	36	MBRD-36	79517	20.5
1050	42	MBRD-42	79518	23.7
1200	48	MBRD-48	79519	26.8
1350	54	MBRD-54	79520	30.7
1500	60	MBRD-60	79521	33.9
1800	72	MBRD-72	79522	41.0
2100	84	MBRD-84	79523	47.5

Optional Mounting Brackets (Pair)

ORDERING NUMBER	ITEM CODE	WT. LBS.
MBCDBK	79536	28.9

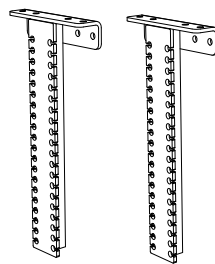

Product Notes:

- Spins opposite the belt direction for optimal cleaning.
- Uniquely patterned bristles aid in reducing material buildup and clogging.
- Adjustable tensioners allow easy brush-to-belt adjustment as the bristles wear.
- Works on mechanically spliced or vulcanised belts.

Stock items (non-shaded) refer to (*) for specific lead time, if not specified, standard lead time applies.

Non-stock items (shaded) please contact Flexco for dispatch options and lead times.

Specifications & Guidelines

Motorised Brush Cleaner

Specifications

Belt Speed	3.5M/sec (Up to 700 fpm)
Vertical and Horizontal Clearance	305mm (12")
Temperature Range	-30°C to 82°C (-20°F to 180°F)
Maximum Chevron or Cleat Height	13mm (1/2")
Bristle Length	83mm (3-1/4")
Overall Diameter	305mm (12")
Shaft Length	Belt Width plus 915mm (36")
Shaft Diameter	38mm (1-1/2")
Motor HP	1 HP cleaners 450-1050mm (1050mm)
	2 HP cleaners 1200-2100mm (48-84")
Motor voltage	230/400V

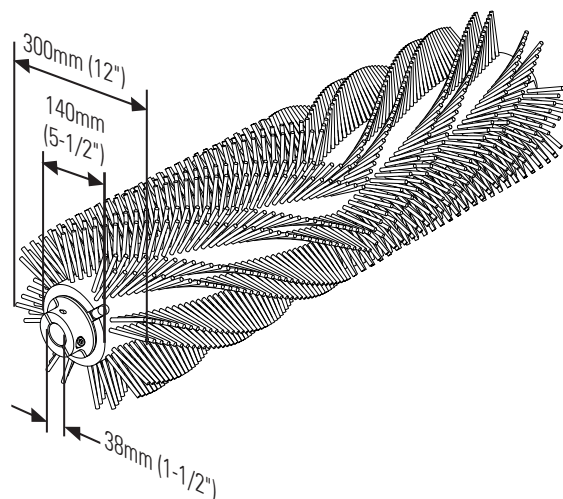
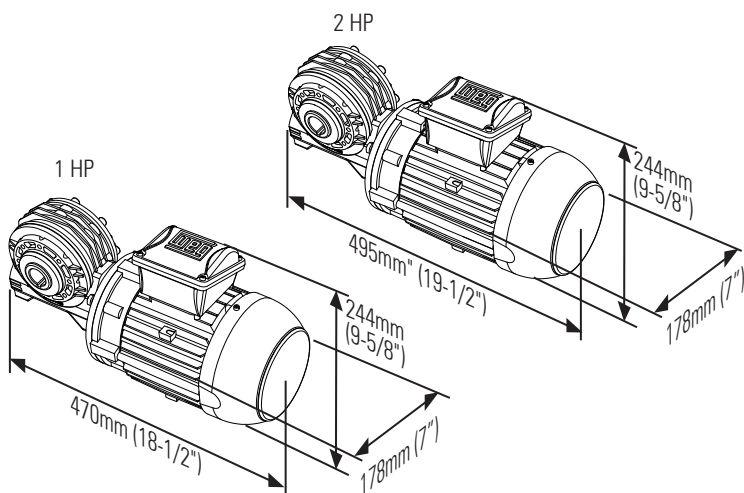
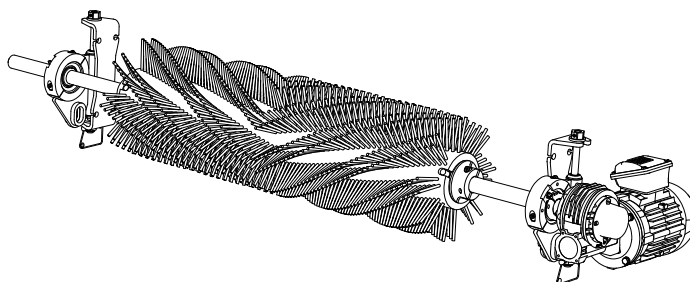

Replacement Parts List

Motorised Brush Cleaner

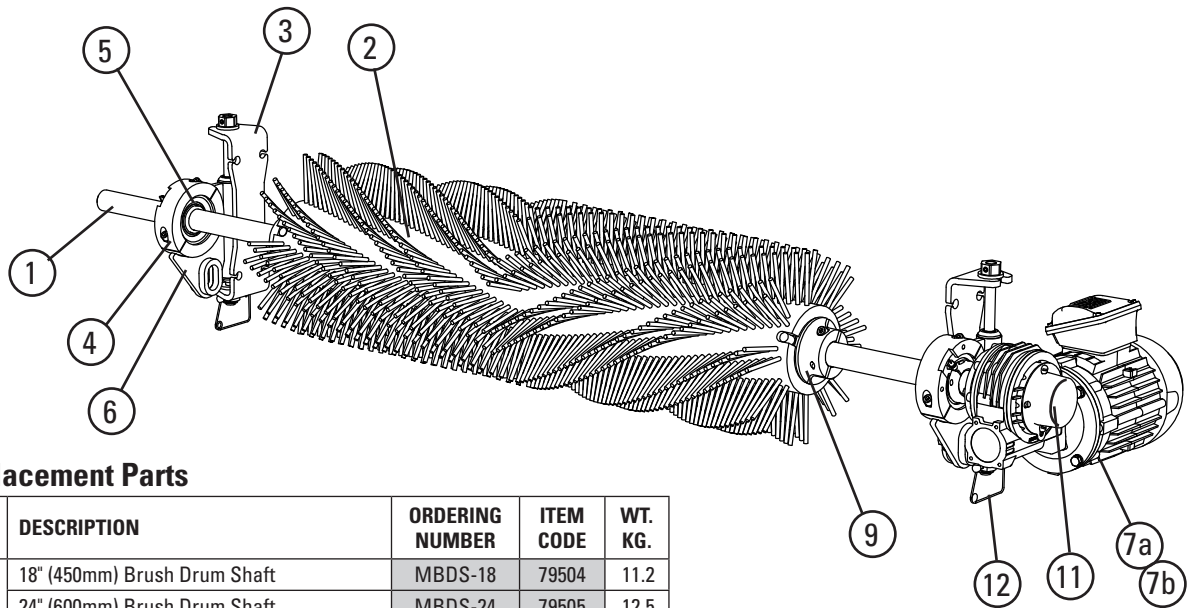

Replacement Parts

REF	DESCRIPTION	ORDERING NUMBER	ITEM CODE	WT. KG.
1	18" (450mm) Brush Drum Shaft	MBDS-18	79504	11.2
	24" (600mm) Brush Drum Shaft	MBDS-24	79505	12.5
	30" (750mm) Brush Drum Shaft	MBDS-30	79506	13.9
	36" (900mm) Brush Drum Shaft	MBDS-36	79507	15.3
	42" (1050mm) Brush Drum Shaft	MBDS-42	79508	16.6
	48" (1200mm) Brush Drum Shaft	MBDS-48	79509	18.0
	54" (1350mm) Brush Drum Shaft	MBDS-54	79510	19.3
	60" (1500mm) Brush Drum Shaft	MBDS-60	79511	20.7
	72" (1800mm) Brush Drum Shaft	MBDS-72	79512	23.4
84" (2100mm) Brush Drum Shaft	MBDS-84	79513	26.1	
2	18" (450mm) Replacement Brush Drum	MBRD-18	79514	4.4
	24" (600mm) Replacement Brush Drum	MBRD-24	79515	6.1
	30" (750mm) Replacement Brush Drum	MBRD-30	79516	7.8
	36" (900mm) Replacement Brush Drum	MBRD-36	79517	9.3
	42" (1050mm) Replacement Brush Drum	MBRD-42	79518	10.8
	48" (1200mm) Replacement Brush Drum	MBRD-48	79519	12.2
	54" (1350mm) Replacement Brush Drum	MBRD-54	79520	14.0
	60" (1500mm) Replacement Brush Drum	MBRD-60	79521	15.4
	72" (1800mm) Replacement Brush Drum	MBRD-72	79522	18.6
84" (2100mm) Replacement Brush Drum	MBRD-84	79523	21.6	
3	Brush Mounting Base* (1)	MBCM	79524	2.1
4	Brush Bearing Clamp* (1)	MBCBC	79525	0.9
5	Brush Cleaner Bearings (2)	MBCB	79526	3.3
6	Brush Bearing Mount* (1)	MBCBM	79528	4.4
7a	Gearmotor Assy, 1 HP for belts up to 42" (1050mm)	MBCM-1	79529	25.0
7b	Gearmotor Assy, 2 HP for belts 48" (1200mm) and up	MBCM-2	79530	29.5
8	Brush Cleaner Torque Arm* (1)	MBCTA	79531	1.1
9	Brush Locks* (2)	MBCBL	79532	4.3
10	Brush Motor Key Kit (1)	MBCMCK	79533	0.1
11	MBC Shaft End Cap* (1)	MBCCEC	79534	0.0
12	Tensioner Lock Pins (2)	STLP	79535	0.1
13	Brush Cleaner Drop Brackets* (2)	MBCDBK	79536	13.1
-	Brush Cleaner Adjusting Bracket (1) (incl. bearing and 1 ea. items 3,4,6,&12)	MBADB	79527	8.2

*Hardware Included

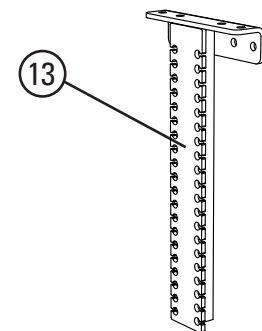
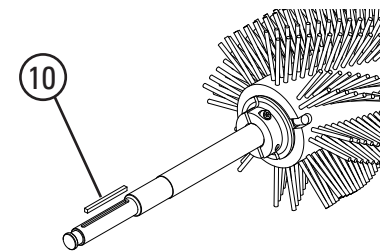
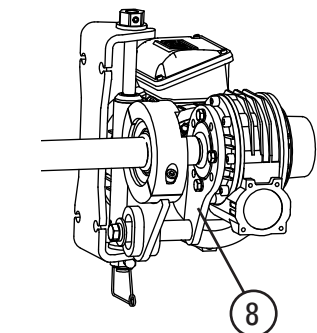

Stock items (non-shaded) refer to (*) for specific lead time, if not specified, standard lead time applies.

Non-stock items (shaded) please contact Flexco for dispatch options and lead times.

Product Ordering Information

Chevron Belt Cleaner

Chevron Belt Cleaner

BELT WIDTH mm	DRUM WIDTH mm	ORDERING NUMBER	ITEM CODE	WT. KG.
450	450	CBC18	76668	34.9
600	600	CBC24	76669	40.0
750	750	CBC30	76670	45.0
900	900	CBC36	76671	50.1
1050	1050	CBC42	76672	55.1
1200	1200	CBC48	76673	60.2
1350	1350	CBC54	76674	65.2
1500	1500	CBC60	76675	70.3



Replacement Parts

REF	DESCRIPTION	ORDERING NUMBER	ITEM CODE	WT. KG.
1	450 mm Drum Shaft	CDS18	76684	6.9
	600 mm Drum Shaft	CDS24	76685	7.7
	750 mm Drum Shaft	CDS30	76686	8.6
	900 mm Drum Shaft	CDS36	76687	9.5
	1050 mm Drum Shaft	CDS42	76688	10.3
	1200 mm Drum Shaft	CDS48	76689	11.2
	1350 mm Drum Shaft	CDS54	76690	12.0
	1500 mm Drum Shaft	CDS60	76691	12.9
2	Chevron Pillow Block*	CPB	76692	0.6
3	450 mm Replacement Drum*	CRD18	76676	12.6
	600 mm Replacement Drum*	CRD24	76677	16.8
	750 mm Replacement Drum*	CRD30	76678	21.0
	900 mm Replacement Drum*	CRD36	76679	25.2
	1050 mm Replacement Drum*	CRD42	76680	29.4
	1200 mm Replacement Drum*	CRD48	76681	33.6
	1350 mm Replacement Drum*	CRD54	76682	37.8
4	1500 mm Replacement Drum*	CRD60	76683	42.0
	Mounting Bracket, Right	PMBR	75519	3.8
4	Mounting Bracket, Left	PMBL	75516	3.8
	5	Adjusting Bracket Kit* (1 ea.)	PAB	75513

*Hardware included

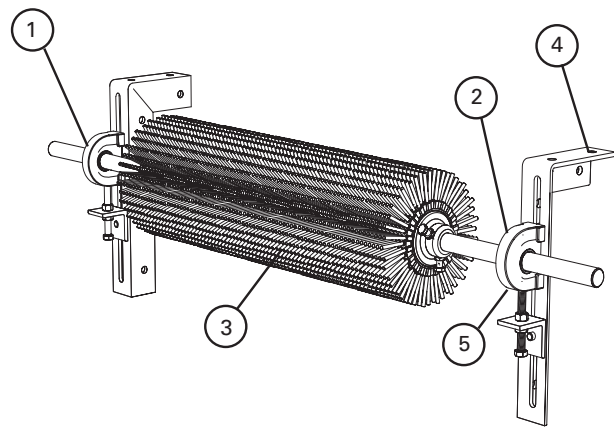

Specifications

Belt Speed	Contact Flexco®
Vertical and Horizontal Clearance	250 mm
Temperature Range	-35°C to 82°C
Maximum Chevron or Cleat Height	25 mm
Finger Length	50 mm
Rubber Durometer	45A
Overall Diameter	238 mm
Shaft Length	Belt Width plus 750 mm
Shaft Diameter	30 mm

Product Notes:

- Free-rotating. Works only when the belt is running.
- Self-cleaning. Finger length, spacing and the rotary action allows carryback to fall free instead of clogging.
- Easy to install. Few parts and step-by-step instructions make the job simple.
- Long-wearing SBR rubber. Drum life ranges from 1 to 3 years depending upon the application conditions and the material being conveyed.
- Works on reversing belts.

Stock items (non-shaded) refer to (*) for specific lead time, if not specified, standard lead time applies.

Non-stock items (shaded) please contact Flexco for dispatch options and lead times.

Product Ordering Information

Wash Box

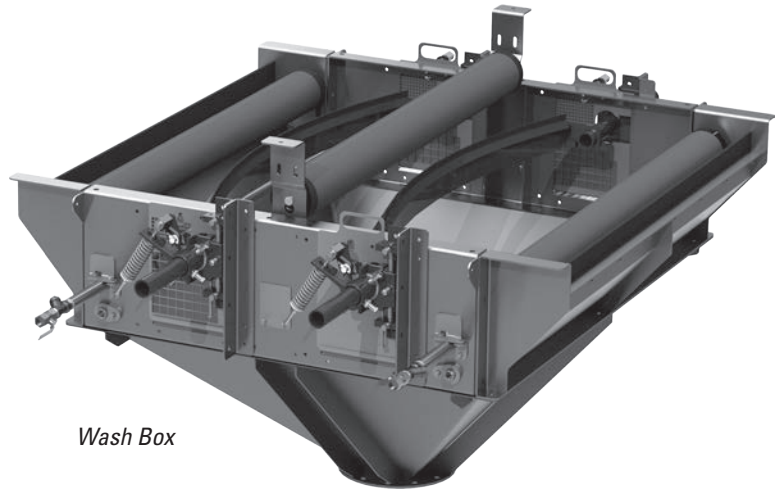

Wash Box

Wash Box

Belt Width	"A"	"B"	"C"	"D"	MASS	VOLUME
	Outside Conveyor Stringers (mm)	Mounting Hole Centres (mm)	Overall Width (mm)	Height to Outlet Flange (mm)	Excludes Cleaners & Rollers (kg)	Enclosed in Wash Box (m ³)
600	910	850	1,085	940	295	0.7
750	1,060	1,000	1,235	955	310	0.8
900	1,210	1,150	1,385	995	330	1.0
1,050	1,360	1,300	1,535	1,015	345	1.1
1,200	1,510	1,450	1,685	1,060	365	1.3
1,350	1,710	1,650	1,885	1,110	390	1.5
1,400	1,760	1,700	1,935	1,125	395	1.6
1,500	1,860	1,800	2,035	1,150	410	1.7
1,600	2,060	2,000	2,235	1,210	435	1.9
1,800	2,260	2,200	2,435	1,265	465	2.2
2,000	2,460	2,400	2,635	1,325	505	2.4

Product Notes:

- Please contact Flexco for pricing and lead time.
- The dimensions, mass and volumes shown here are nominal for a standard Flexco Wash Box and will be confirmed to suit each specific application.
- Each Stainless Steel Wash Box comes equipped with a combination of pressure rollers, spray bars and recovery system.
- The Wash Box is designed to accommodate any two secondary cleaners from the Flexco range, the belt cleaners are sold separately.
- Manufactured in Bundaberg, QLD, Australia.
- Non-standard sizes available, please contact Flexco.

Stock items (non-shaded) refer to (*) for specific lead time, if not specified, standard lead time applies.

Non-stock items (shaded) please contact Flexco for dispatch options and lead times.

Product Ordering Information

Inspection Doors

300 mm x 300 mm Door

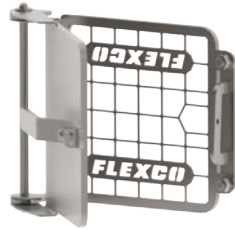

400 mm x 400 mm Door



500 mm x 500 mm Door

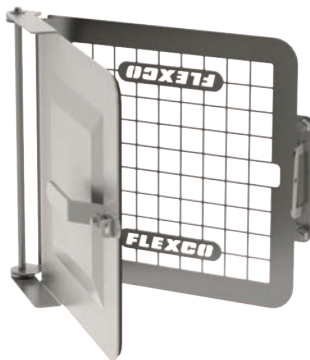

600 mm x 600 mm Door





Inspection Doors

Chute Opening mm	Item Code	Ordering Number	Weight kg
300 x 300	62445	ID300x300 S/S Inspection Door	8.0
400 x 400	62446	ID400x400 S/S Inspection Door	13.0
500 x 500	62447	ID500x500 S/S Inspection Door	18.0
600 x 600	62448	ID600x600 S/S Inspection Door	32.0

Product Notes:

- Please contact Flexco for pricing and lead time.
- The inspection doors are available in four different sizes to suit multiple chute openings
- Constructed from heavy-duty grade 316 stainless steel
- The solid outer door can be safely opened by hand without the need for any tools during normal operation of the equipment.
- The inner door features 3mm mesh at 50mm spacing and requires tools to remove ensuring workers remain safe behind the mesh.

 **Stock items** (non-shaded) refer to (*) for specific lead time, if not specified, standard lead time applies.

 **Non-stock items** (shaded) please contact Flexco for dispatch options and lead times.

Specifications & Guidelines

Inspection Doors

Inspection Door 300 mm x 300 mm

Chute Opening:	300 mm x 300 mm
Outer Door:	Solid c/w Lockable Handle
Inner Mesh Door:	3 mm mesh @ 50 mm spacing
Material:	Grade 316 Stainless Steel
Overall Weight:	8 kg

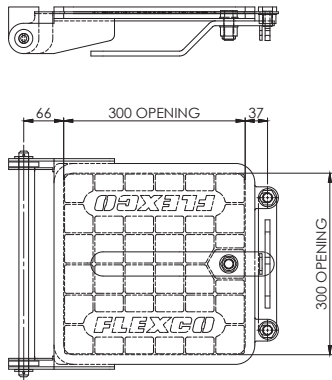

Inspection Door 400 mm x 400 mm

Chute Opening:	400 mm x 400 mm
Outer Door:	Solid c/w Lockable Handle
Inner Mesh Door:	3 mm mesh @ 50 mm spacing
Material:	Grade 316 Stainless Steel
Overall Weight:	13 kg

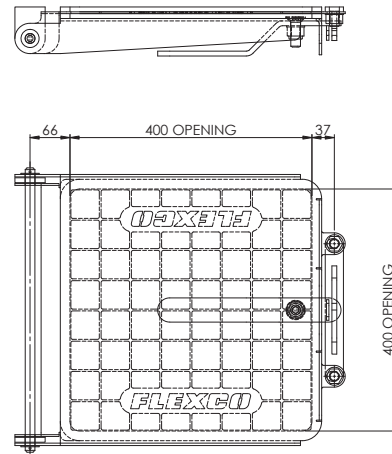

Inspection Door 500 mm x 500 mm

Chute Opening:	500 mm x 500 mm
Outer Door:	Solid c/w Lockable Handle
Inner Mesh Door:	3 mm mesh @ 50 mm spacing
Material:	Grade 316 Stainless Steel
Overall Weight:	18 kg

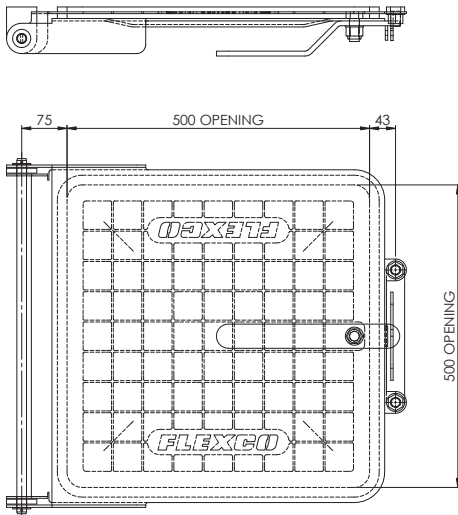

Inspection Door 600 mm x 600 mm

Chute Opening:	600 mm x 600 mm
Outer Door:	Solid c/w Lockable Handle
Inner Mesh Door:	3 mm mesh @ 50 mm spacing
Material:	Grade 316 Stainless Steel
Overall Weight:	32 kg

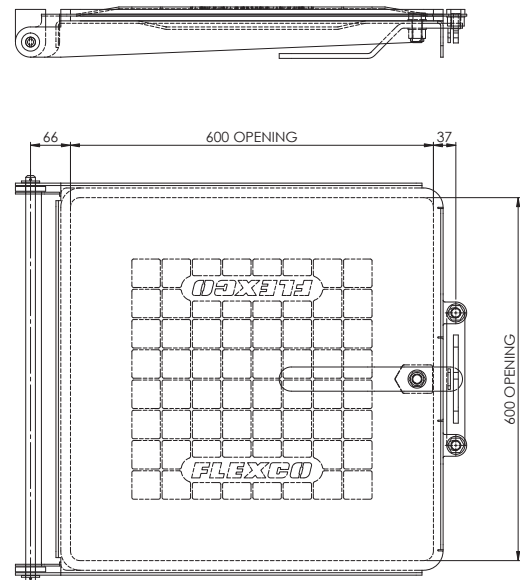

Product Ordering Information

Water Spray Pole Systems Belt Cleaner Accessories

Stand-Alone Spraybar Assemblies 38 mm dia.

BELT WIDTH mm	ORDERING NUMBER	ITEM CODE	WT. KG.
600	SB600A	A0887	4.0
750	SB750A	A0407	5.0
900	SB900A	A0912	5.5
1050	SB1050A	A0435	6.0
1200	SB1200A	A0316	7.0
1400	SB1400A	A1620	8.0
1500	SB1500A	A1838	9.0
1800	SB1800A	A1357	10.0

Spray Assembly includes spraybar, brass plug, y strainer, nozzles, and brackets to mount independently to structure.



Secondary Spraybar Assemblies

BELT WIDTH mm	ORDERING NUMBER	ITEM CODE	WT. KG.
600	SB600-SEC	61063	4.0
750	SB750-SEC	61064	5.0
900	SB900-SEC	61065	5.5
1050	SB1050-SEC	61066	6.0
1200	SB1200-SEC	61067	7.0
1400	SB1400-SEC	61068	8.0
1500	SB1500-SEC	61069	9.0
1800	SB1800-SEC	61070	10.0

Secondary Cleaner Spraybar Assemblies are designed to be clamped to secondary cleaners. Each assembly includes spraybar, nozzles, brass plug, y strainer, and clamping brackets to mount to secondary cleaner.

Lead time: 3 weeks



Water Control Manifold

ORDERING NUMBER	ITEM CODE	WT. KG.
WCB	A0012	10.0

Water Control Manifolds come complete with the following:

- 13 mm BSP connections
- Solenoid valve (24V DC Standard)
- Pressure regulator
- Filter strainer
- Lockable ball valves
- Manual bypass line
- Stainless steel backing plate



Spray Nozzles Per Cleaner Size

mm	450	600	750	900	1050	1200	1350	1500	1800	2100	2400	3000
Spray Nozzles	1	2	2	3	3	4	4	5	6	7	8	10

 Stock items (non-shaded) refer to (*) for specific lead time, if not specified, standard lead time applies.

 Non-stock items (shaded) please contact Flexco for dispatch options and lead times.

Product Ordering Information

Water Spray Pole Systems Belt Cleaner Accessories

PS Spraywash with V-Tips

BELT WIDTH mm	ORDERING NUMBER	ITEM CODE	WT. KG.
600	PS600	73014	27.0
750	PS750	73541	31.0
900	PS900	73542	33.0
1050	PS1050	73543	37.0
1200	PS1200	73544	40.0
1400	PS1400	73546	42.0
1500	PS1500	73545	47.0
1800	PS1800	73537	62.0
2000	PS2000	73539	68.0

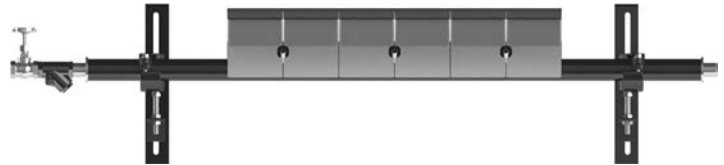

All Stainless Steel construction. Spraywash cleaners supplied standard with nozzles, deflector shields, Brass plug, and brass Y strainer.
Lead time: 3 weeks

Replacement Tips and Nozzles

BELT WIDTH mm	600	750	900	1050	1200	1400	1500	1800	2000
Tips/Cushions Required	4	5	6	7	8	9	10	12	13
Nozzles Required	2	3	3	3	4	5	5	6	7

Replacement Parts

REF	DESCRIPTION	POLE DIAMETER	BELT WIDTH	POLE LENGTH	ORDERING NUMBER	ITEM CODE	WT. KG.
1	PS Spray Poles	60	600	1350	PS600PL*	73582	15.0
			750	1500	PS750PL*	73583	16.0
			900	1650	PS900PL*	73584	19.0
			1050	1800	PS1050PL*	73585	22.0
			1200	1950	PS1200PL*	73586	26.0
		73	1400	2200	PS1400PL*	73587	29.0
			1500	2350	PS1500PL*	73588	33.0
			1800	2650	PS1800PL*	74049	36.0
			2000	2850	PS2000 PL*	74050	40.0
2	P-V Tip				PVT6-S/S	75420	0.4
3	PH High Speed Cushion - Stainless				PHSC-S/S	73433	1.0
4	Spray Nozzle				PSN11010	74053	1.0
5	Valve Assembly				PSVA	73434	1.0
6	Water Control Board - 24 Volt DC				WCB	A0012	10.0
-	Stainless Shield - Notch				PSSS-N	73221	0.5
-	Stainless Shield - Hole				PSSS-H	73222	0.5

Hardware included

*Lead time: 3 weeks

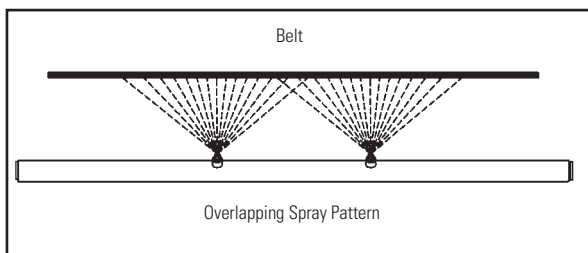

Specifications

- Stainless steel pole with stainless steel clamping brackets.
- Spray nozzles are spaced on 300 mm centers.
- Delivers 3.7 liters per nozzle per minute at 414 kPa.
- Maximum inlet pressure is 2069 kPa.
- Typical pressure setting is 276-414 kPa.

Stock items (non-shaded) refer to (*) for specific lead time, if not specified, standard lead time applies.

Non-stock items (shaded) please contact Flexco for dispatch options and lead times.

Product Ordering Information

Mandrel Safety Removal Systems Belt Cleaner Accessories

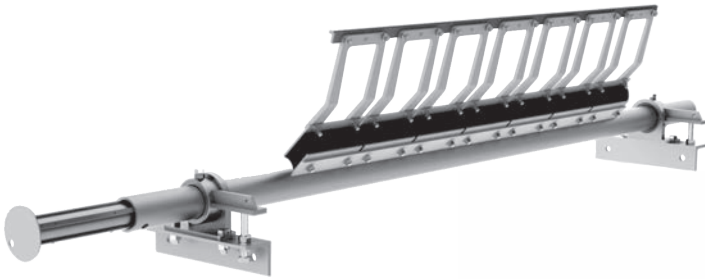

H-Type® primary cleaner shown (cleaner not included)

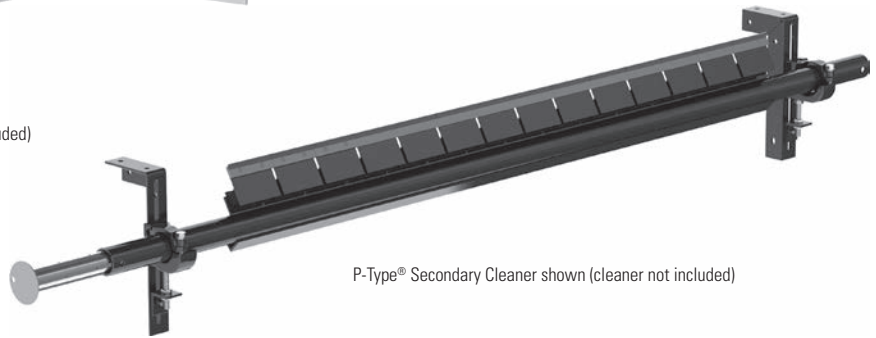

P-Type® Secondary Cleaner shown (cleaner not included)

Mandrel Poles

BELT WIDTH mm	CLEANER POLE DIA.	GALVANISED MANDREL POLE		
		ORDERING NUMBER	ITEM CODE	WT. KG.
450	60	MR-450PG	A2836	5.0
600	60	MR-600PG	A2837	6.0
750	60	MR-750PG	A2838	6.5
900	60	MR-900PG	A2839	7.5
1050	60	MR-1050PG	A2840	8.5
1200	60	MR-1200PG	A2841	9.0
1500	73	MR-1500PG	A2829	10.0
1600	73	MR-1600PG	A2830	11.0
1800	73	MR-1800PG	A2831	12.0
2100	73	MR-2100PG	A2832	13.5
2400	73	MR-2400PG	A2833	15.0
2600	73	MR-2600PG	A2834	16.5
3000	73	MR-3000PG	A2835	19.0

A Mandrel Kit requires 1 pole, 1 left hand block and 1 right hand block.

Lead time: 3 weeks

Cradle H Bearings Primary Cleaners

POWDER COATED			
ORDERING NUMBER	ITEM CODE	POLE DIA.	WT. KG.
PMR-CHB-L73	61075	73	1.5
PMR-CHB-R73	61076	73	1.5
PMR-CHB-L60	61073	60	1.3
PMR-CHB-R60	61074	60	1.3

Cradle Clamp Blocks Secondary Cleaners

POWDER COATED		
ORDERING NUMBER	ITEM CODE	POLE DIA.
SMR-CCB-L73	A2842	73
SMR-CCB-R73	A2843	73
SMR-CCB-L60	A2844	60
SMR-CCB-R60	A2845	60

 Stock items (non-shaded) refer to (*) for specific lead time, if not specified, standard lead time applies.

 Non-stock items (shaded) please contact Flexco for dispatch options and lead times.

Product Ordering Information

Live-Shaft Hold-Down Roll Belt Cleaner Accessories

Live-Shaft Hold-Down Roll

BELT WIDTH		ROLL DIAMETER		ORDERING NUMBER	ITEM CODE	WT. KG.
mm	in.	mm	in.			
600	24	114	4 1/2	HDR24	79010	72.3
750	30	114	4 1/2	HDR30	79011	76.8
900	36	114	4 1/2	HDR36	79012	81.8
1050	42	114	4 1/2	HDR42	79013	86.4
1200	48	114	4 1/2	HDR48	79014	113.2
1350	54	114	4 1/2	HDR54	79015	115.9
1500	60	114	4 1/2	HDR60	79016	120.5
1800	72	127	5	HDRS72*	79017	256.8
2100	84	127	5	HDRS84*	79018	279.5

*1800mm and 2100mm (72" and 84") feature solid roll

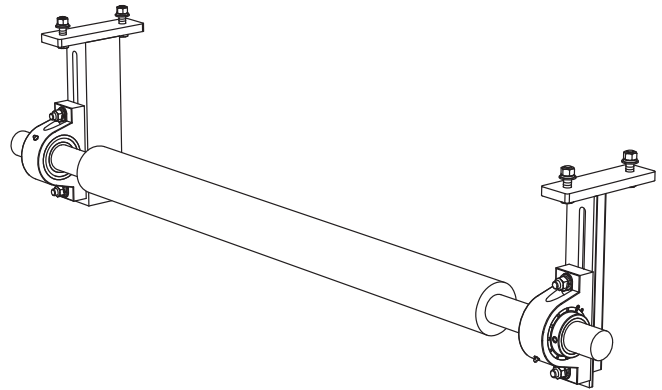

Replacement Roll

BELT WIDTH		ROLL DIAMETER		ORDERING NUMBER	ITEM CODE	WT. KG.
mm	in.	mm	in.			
600	24	114	4 1/2	HDRR24	79019	51.8
750	30	114	4 1/2	HDRR30	79020	56.4
900	36	114	4 1/2	HDRR36	79021	61.4
1050	42	114	4 1/2	HDRR42	79022	65.9
1200	48	114	4 1/2	HDRR48	79023	92.7
1350	54	114	4 1/2	HDRR54	79024	95.5
1500	60	114	4 1/2	HDRR60	79025	100.0
1800	72	127	5	HDRRS72*	79026	236.4
2100	84	127	5	HDRRS84*	79027	259.1

*1800mm and 2100mm (72" and 84") feature solid roll

Roller Bracket Kit*

DESCRIPTION	ORDERING NUMBER	ITEM CODE	WT. KG.
Hold Down Roll Bracket Kit - 600mm to 1500mm	HDRBK	79009	20.5
HD Hold Down Roll Bracket Kit - 1800mm to 2100mm	HDRBK-HD	79072	20.5

*Includes Left and Right Bracket

Add-On Grease Hose Extension Kit

DESCRIPTION	ORDERING NUMBER	ITEM CODE	WT. KG.
Grease Hose Extension Kit (incl. 2 ea. 400mm (16") hose w/fittings and tie-downs)	HDRGEK	79236	0.5

Specifications:

- Overall Roll Length.....Belt Width 150mm (+6")
- Overall Shaft LengthBelt Width 750mm (+30")
- Shaft Diameter.....600-1050mm (24"- 42") - 49.2mm (1-15/16") diameter
1200-1500mm (48"- 60") - 61.9mm (2-7/16") diameter
1800-2100mm (72"- 84") - 74.6 (2-15/16") diameter
- Shaft Construction600-1500mm (24"- 60") - 1045 CD
1800-2100mm (72"- 84") - turned from solid 4140 round stock

Product Notes:

- For use in applications with belt cup or belt flap.
- By preventing these issues secondary cleaner performance and blade/tip life is enhanced.

Stock items (non-shaded) refer to (*) for specific lead time, if not specified, standard lead time applies.

Non-stock items (shaded) please contact Flexco for dispatch options and lead times.

Product Ordering Information

Standard Pulley Lifters

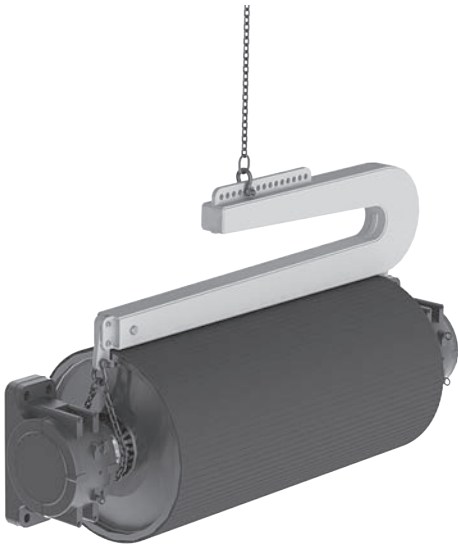



Pulley Face Widths

	800-1200	1200-1600	1600-2000	2000-2400
3 TONNE CAPACITY	1-PL-800-1200-3	1-PL-1200-1600-3	1-PL-1600-2000-3	1-PL-2000-2400-3
6 TONNE CAPACITY	1-PL-800-1200-6	1-PL-1200-1600-6	1-PL-1600-2000-6	1-PL-2000-2400-6
12 TONNE CAPACITY	1-PL-800-1200-12	1-PL-1200-1600-12	1-PL-1600-2000-12	1-PL-2000-2400-12

Product Notes:

- Please contact Flexco for pricing and lead times.
- Designed and manufactured in Bundaberg, QLD, Australia.
- Made from high strength steel to Australian Standards.
- Each pulley lifter proof load tested after manufacture and supplied with certificate of compliance and a safety operations and maintenance manual.
- Supplied in safety yellow as standard (other colours available on request).

 **Stock items** (non-shaded) refer to (*) for specific lead time, if not specified, standard lead time applies.

 **Non-stock items** (shaded) please contact Flexco for dispatch options and lead times.

Product Ordering Information

Belt Cleaner Accessories

Stabilising Roller Bracket Kit*

Provides universal brackets to mount the user's return roller as a hold-down (stabilising) roller on top of the return side belt. Holds the belt flat so the belt cleaner can maximize its cleaning performance.

DESCRIPTION	ORDERING NUMBER	ITEM CODE	WT. KG.
Stabilising Roller Bracket Kit	SRBK	74941	15.5

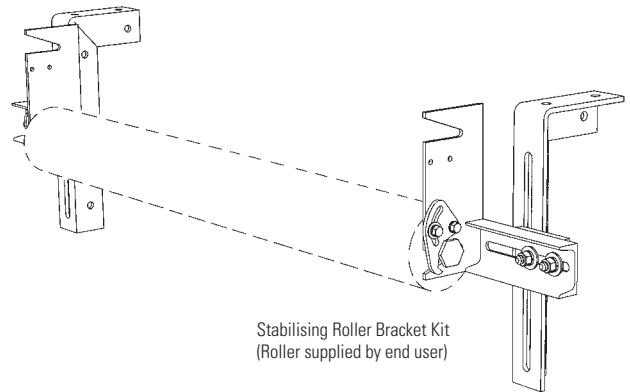

Hold Down Roll Assembly Kits

DESCRIPTION	ORDERING NUMBER	ITEM CODE	WT. KG.
Hold Down Roll Assembly Kit S/S 17mm*	HDRP17	63679	1.9
Hold Down Roll Assembly Kit S/S 22mm*	HDRP22	63678	1.9

Kit includes:

- Stainless Steel Hold Down Roller Pole Kit to suit 17mm or 22mm A/F Roller
- S/S Mounting Kit

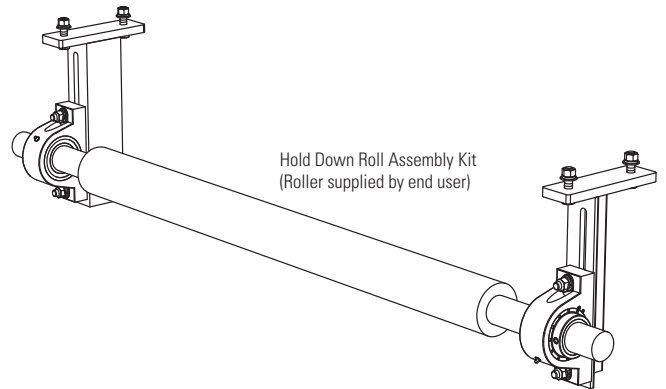

Tip Tension Scale

For easy checking of blade tension on all H-Type® Primary Cleaners.

DESCRIPTION	ORDERING NUMBER	ITEM CODE	WT. KG.
H Tip Tension Scale	HTTS	74141	0.1

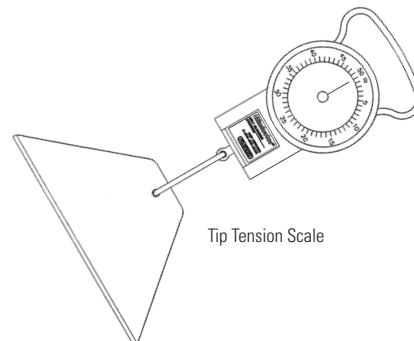

Spring Tension Chart (recommended tensions)

CLEANER	HXF	H V-TIP	H PROTECTED V-TIP	HI-TEMP V-TIP
Kg	12.7	8.2	8.2	8.2

For installation and for retensioning blades during maintenance.

Belt Cleaner Handy Wrench

A ratcheting wrench with 2 common socket sizes (11/16" & 3/4", 17mm & 19mm) for belt cleaner installation and maintenance.

DESCRIPTION	ORDERING NUMBER	ITEM CODE	WT. KG.
Belt Cleaner Handy Wrench	HW-BC	74100	0.6

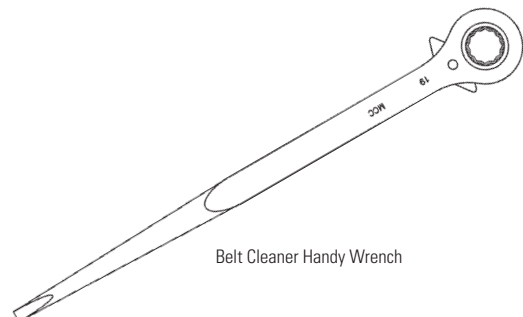

Stock items (non-shaded) refer to (*) for specific lead time, if not specified, standard lead time applies.

Non-stock items (shaded) please contact Flexco for dispatch options and lead times.

Product Ordering Information

Belt Cleaner Accessories

OPTIONAL MOUNTING KITS FOR BELT CLEANERS

Versatile, adjustable brackets and plates that can be mounted on the conveyor structure so Primary Cleaners and secondary cleaners can be easily and quickly bolted into place.



75830

- Optional Mounting Bar Kit
(with bolts, nuts and washers)
- For mounting primary cleaners on open head pulleys.
 - Weld on both sides of pulley and bolt on steel plates.
 - For use with MMP, MHCP

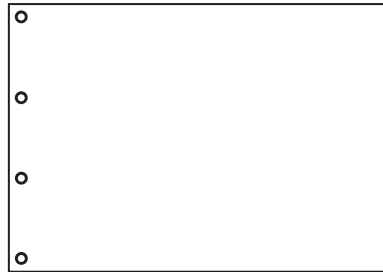

76537

- Mounting Plate Kit (incl. 2 plates, 400 x 800 mm)
- For use with Mounting Bars to mount cleaners on open head pulleys.
 - For use with MMP, MHCP

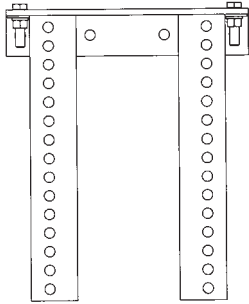

76071

- Standard Mounting Bracket Kit
- For most secondary cleaner installs.

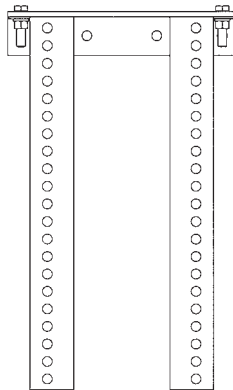

76072

- Long Mounting Bracket Kit
- For installations that require extra length legs.

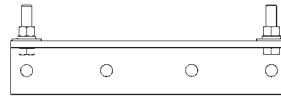

76073

- Optional Top Angle Kit
- Used with both standard and long mounting bracket kits for additional mounting options.

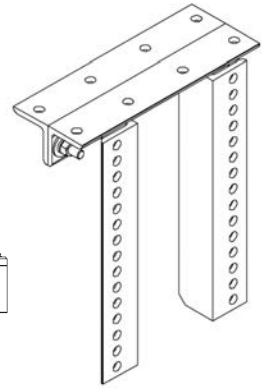

Optional Mounting Kits

(includes 2 brackets/bars)

DESCRIPTION	ORDERING NUMBER	ITEM CODE	WT. KG.
Standard Mounting Bracket Kit*	SSTSMB	76071	15.6
Long Mounting Bracket Kit*	SSTLMB	76072	19.7
Optional Top Angle Kit*	SSTOTA	76073	4.8
Optional Mounting Bar Kit*	MMBK	75830	8.8
Mounting Plate Kit (incl. 2 plates)	MMPK	76537	63.5

Hardware Included

Specifications

- Standard brackets are 330 mm W x 394 mm L.
- Long brackets are 330 mm W x 546 mm L.
- Mounting bars are 38 mm W x 406 mm L with (4) 16-279 mm tapped holes.
- Mounting plates are 406 mm W x 813 mm L with (4) 16 mm holes.

Pole Extender Kit

(includes 2 pole extenders)

DESCRIPTION	ORDERING NUMBER	ITEM CODE	WT. KG.
Pole Extender Kit	MAPEK	76024	9.9

Provides 750 mm of extended pole length.

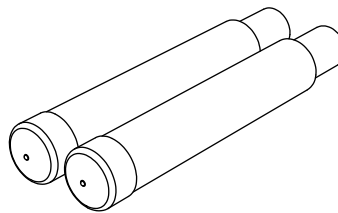

Stock items (non-shaded) refer to (*) for specific lead time, if not specified, standard lead time applies.

Non-stock items (shaded) please contact Flexco for dispatch options and lead times.

Specifications & Guidelines

Flexco® Slider/Impact Beds

Easy Solution for Load Zone Problems

- Complete load zone offering with slider beds through impact beds for up to 100 kg-m of force.
- No specifying trough angle; each bed is adjustable for 20°, 35° and 45° trough settings (ships at 35° setting)
- Low-profile installation. Because Flexco® beds feature trough wings that are adjustable, they lay flat during installation, providing more clearance.
- Full UHMW slider bars included on outside bar to provide proper sealing and long life.
- Unique Impact Bar Supports protect the impact bars from damage, extending service life. An Anti-Migratory Tab on each support secures the bar and prevents it from sliding in the direction of belt travel.
- All beds are manufactured for mounting holes belt width + 250mm (600-1200mm beds), + 300mm (1350-1500mm beds), and + 400mm (1800mm beds). For wider structure, contact Customer Service for special quote.

How to spec the correct slider/impact bed for your conveyor transfer point

Roller Size
 127mm 152mm 178mm
Belt Width: _____
Bed Length: 1200mm 1500mm

Impact Energy Calculation Chart

Drop Height (h)

Largest Material Lump Weight (w)

Impact Energy

Lump Weight (w) _____
 Drop Height (h) x _____
 Total = **kg-m** See Below

0 kg-m — EZSB-C
 0 - 25kg-m — EZSB-I or EZIB-L
 25-100 kg-m — EZIB-M

Product Ordering Information

EZSB-C
Flexco® Slider Beds
CoreTech™ Rolls



Flexco Slider Bed with CoreTech™ Rolls 1200mm (for non-impact areas)

BELT WIDTH mm	ORDERING NUMBER	ITEM CODE	WT. KG.
600	EZSB600-1200C	82185	110.7
750	EZSB750-1200C	82186	119.4
900	EZSB900-1200C	82187	131.1
1050	EZSB1050-1200C	82188	162.7
1200	EZSB1200-1200C	82189	175.0
1350	EZSB1350-1200C	82190	206.4
1500	EZSB1500-1200C	82191	217.1
1800	EZSB1800-1200C	82192	232.7

Lead time: 4 weeks

Flexco Slider Bed with CoreTech™ Rolls 1500mm (for non-impact areas)

BELT WIDTH mm	ORDERING NUMBER	ITEM CODE	WT. KG.
600	EZSB600-1500C	82193	118.4
750	EZSB750-1500C	82194	126.9
900	EZSB900-1500C	82195	138.6
1050	EZSB1050-1500C	82196	173.7
1200	EZSB1200-1500C	82197	186.2
1350	EZSB1350-1500C	82198	221.4
1500	EZSB1500-1500C	82199	232.1
1800	EZSB1800-1500C	82200	247.6

Lead time: 4 weeks

Adjustable Idler Set with CoreTech™ Rolls

(for placement in between 3 or more beds)



BELT WIDTH mm	ORDERING NUMBER	ITEM CODE	WT. KG.
600	EZAI-600	82410	36.2
750	EZAI-750	82411	40.8
900	EZAI-900	82412	45.7
1050	EZAI-1050	82413	49.9
1200	EZAI-1200	82414	55.9
1350	EZAI-1350	82415	60.1
1500	EZAI-1500	82416	64.1
1800	EZAI-1800	82417	74.2

Lead time: 4 weeks

Product Notes:

- No need to specify troughing angle—designed to adjust to 20°, 35°, 45°.
- Designed for containment in the load zone, but not intended for impact zones.
- Slider bars are solid 25mm UHMW providing longer wear life and consistent load zone sealing.
- Product ships with two idlers. Additional idlers can be added by purchasing a EZRMK and the appropriate corresponding idler.

Replacement Parts List

EZSB-C
Flexco® Slider Beds
CoreTech™ Rolls

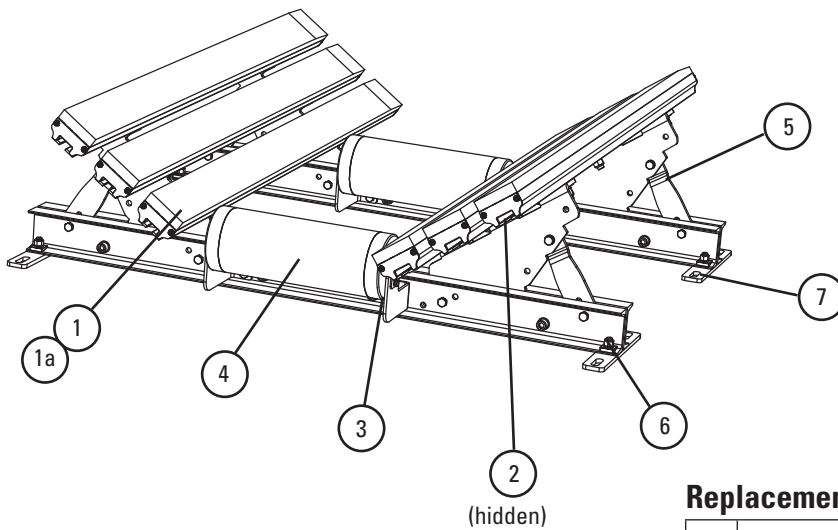

Replacement Parts

REF	DESCRIPTION	ORDERING NUMBER	ITEM CODE	WT. KG.
1	Slider Bar, 1200mm	SB4	78789	9.1
1a	Slider Bar, 1500mm	SB5	78790	10.9
2	Bar Bolt Kit (incl. 1 ea. 16mm carriage bolt, square washer, flat washer, lock washer, Nylock nut)	RIBBK	81250	0.2
3	Slider Roll Mount Kit*	EZRMKM	82344	2.3
4	CoreTech™ Roll 600mm	N6D3T-24-9-A45	26107	4.1
	CoreTech Roll 750mm	N6D3T-30-11-A45	26108	4.8
	CoreTech Roll 900mm	N6D3T-36-13-A45	26109	5.6
	CoreTech Roll 1050mm	N6D3T-42-15-A45	26110	6.3
	CoreTech Roll 1200mm	N6D3T-48-17-A45	26111	7.3
	CoreTech Roll 1350mm	N6D3T-54-19-A45	26112	7.7
	CoreTech Roll 1500mm	N6D3T-60-21-A45	26113	8.2
	CoreTech Roll 1800mm	N6D3T-72-25-A45	26114	9.8
5	Wing Plate Kit 600mm*	EZWPK-600	82345	7.7
	Wing Plate Kit 750mm*	EZWPK-750	82346	7.9
	Wing Plate Kit 900mm*	EZWPK-900	82347	9.6
	Wing Plate Kit 1050mm*	EZWPK-1050	82348	11.9
	Wing Plate Kit 1200mm*	EZWPK-1200	82349	13.7
	Wing Plate Kit 1350mm*	EZWPK-1350	82350	16.1
	Wing Plate Kit 1500mm*	EZWPK-1500	82351	17.7
	Wing Plate Kit 1800mm*	EZWPK-1800	82352	21.2
6	Cross Stringer Kit 600mm*	EZCSK-600	82353	22.3
	Cross Stringer Kit 750mm*	EZCSK-750	82354	25.6
	Cross Stringer Kit 900mm*	EZCSK-900	82355	28.9
	Cross Stringer Kit 1050mm*	EZCSK-1050	82356	32.1
	Cross Stringer Kit 1200mm*	EZCSK-1200	82357	35.6
	Cross Stringer Kit 1350mm*	EZCSK-1350	82358	38.9
	Cross Stringer Kit 1500mm*	EZCSK-1500	82359	42.2
	Cross Stringer Kit 1800mm*	EZCSK-1800	82360	45.0
7	Shim Kit Light Duty (incl. 4 shims)	SHIM-LDKIT	82393	6.2

*Hardware Included. Lead time: 4 weeks.

Replacement Quantities for EZSB-C

mm	600	750	900	1050	1200	1350	1500	1800
ROLLS REQUIRED	2	2	2	2	2	2	2	2
BARS REQUIRED	SLIDER	4	4	4	6	6	8	8
BAR BOLT KITS REQUIRED	8	8	8	12	12	16	16	16

Product Ordering Information

EZSB-I **Flexco® Slider Beds** **CoreTech™ Impact Rolls**



Flexco Slider Bed with CoreTech™ Impact Rolls 1200mm

(for impact zones with less than 25 Kg-m energy)

BELT WIDTH mm	ORDERING NUMBER	ITEM CODE	WT. KG.
600	EZSB600-1200I	82201	125.6
750	EZSB750-1200I	82202	136.1
900	EZSB900-1200I	82203	149.7
1050	EZSB1050-1200I	82204	184.7
1200	EZSB1200-1200I	82205	198.2
1350	EZSB1350-1200I	82206	233.1
1500	EZSB1500-1200I	82207	246.3
1800	EZSB1800-1200I	82208	265.8

Lead time: 4 weeks

Flexco Slider Bed with CoreTech™ Impact Rolls 1500mm

(for impact zones with less than 25 Kg-m energy)

BELT WIDTH mm	ORDERING NUMBER	ITEM CODE	WT. KG.
600	EZSB600-1500I	82209	133.4
750	EZSB750-1500I	82210	143.8
900	EZSB900-1500I	82211	157.5
1050	EZSB1050-1500I	82212	196.4
1200	EZSB1200-1500I	82213	210.0
1350	EZSB1350-1500I	82214	248.9
1500	EZSB1500-1500I	82215	262.1
1800	EZSB1800-1500I	82216	281.3

Product Notes:

- No need to specify troughing angle—designed to adjust to 20°, 35°, 45°.
- Outermost trough bar features 25mm solid UHMW slider bar to provide longer wear life and consistent load zone sealing where impact is not present.

Replacement Parts List

EZSB-I
Flexco® Slider Beds
CoreTech™ Impact Rolls

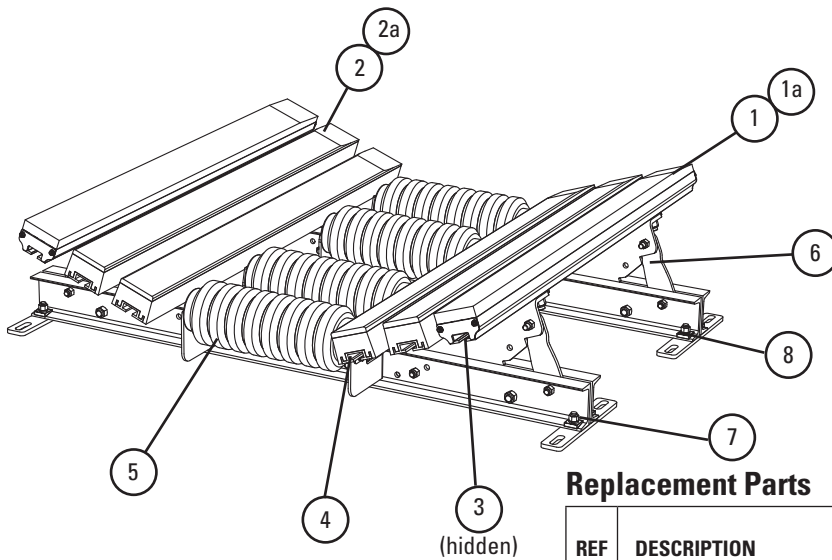

Replacement Parts

REF	DESCRIPTION	ORDERING NUMBER	ITEM CODE	WT. KG.
1	Slider Bar, 1200mm	SB4	78789	9.1
1a	Slider Bar, 1500mm	SB5	78790	10.9
2	Impact Bar, 1200mm	IB4	76926	7.7
2a	Impact Bar, 1500mm	IB5	76927	9.5
3	Bar Bolt Kit (incl. 1 ea. 16mm carriage bolt, square washer, flat washer, lock washer, Nylock nut)	RIBBK	81250	0.2
4	Slider Roll Mount Kit*	EZRMKM	82344	2.3
5	Impact CoreTech™ Roll 600mm	NI6D3T-24-9-A45	26184	4.6
	Impact CoreTech Roll 750mm	NI6D3T-30-11-A45	26185	5.4
	Impact CoreTech Roll 900mm	NI6D3T-36-13-A45	26186	6.3
	Impact CoreTech Roll 1050mm	NI6D3T-42-15-A45	26187	7.3
	Impact CoreTech Roll 1200mm	NI6D3T-48-17-A45	26188	8.1
	Impact CoreTech Roll 1350mm	NI6D3T-54-19-A45	26189	9.0
	Impact CoreTech Roll 1500mm	NI6D3T-60-21-A45	26190	9.8
	Impact CoreTech Roll 1800mm	NI6D3T-72-25-A45	26191	11.6
6	Wing Plate Kit 600mm*	EZWPK-600	82345	7.7
	Wing Plate Kit 750mm*	EZWPK-750	82346	7.9
	Wing Plate Kit 900mm*	EZWPK-900	82347	9.6
	Wing Plate Kit 1050mm*	EZWPK-1050	82348	11.9
	Wing Plate Kit 1200mm*	EZWPK-1200	82349	13.7
	Wing Plate Kit 1350mm*	EZWPK-1350	82350	16.1
	Wing Plate Kit 1500mm*	EZWPK-1500	82351	17.7
	Wing Plate Kit 1800mm*	EZWPK-1800	82352	21.2
7	Cross Stringer Kit 600mm*	EZCSK-600	82353	22.3
	Cross Stringer Kit 750mm*	EZCSK-750	82354	25.6
	Cross Stringer Kit 900mm*	EZCSK-900	82355	28.9
	Cross Stringer Kit 1050mm*	EZCSK-1050	82356	32.1
	Cross Stringer Kit 1200mm*	EZCSK-1200	82357	35.6
	Cross Stringer Kit 1350mm*	EZCSK-1350	82358	38.9
	Cross Stringer Kit 1500mm*	EZCSK-1500	82359	42.2
	Cross Stringer Kit 1800mm*	EZCSK-1800	82360	45.0
8	Shim Kit Light Duty (incl. 4 shims)	SHIM-LDKIT	82393	6.2

*Hardware Included. Lead time: 4 weeks.

Replacement Quantities for EZSB-I

mm	600	750	900	1050	1200	1350	1500	1800
ROLLS REQUIRED	4	4	4	4	4	4	4	4
BARS REQUIRED	SLIDER	2	2	2	2	2	2	2
	IMPACT	2	2	2	4	4	6	6
BAR BOLT KITS REQUIRED	8	8	8	12	12	16	16	16

Product Ordering Information

EZIB-L
Flexco® Impact Beds
All Bars - Light Duty



Flexco® Impact Bed Light Duty 1200mm

(for impact zones with less than 25 Kg-m energy)

BELT WIDTH mm	ORDERING NUMBER	ITEM CODE	WT. KG.
600	EZIB600-1200L	82217	138.0
750	EZIB750-1200L	82218	145.6
900	EZIB900-1200L	82219	174.5
1050	EZIB1050-1200L	82220	206.1
1200	EZIB1200-1200L	82221	235.1
1350	EZIB1350-1200L	82222	267.2
1500	EZIB1500-1200L	82223	295.7
1800	EZIB1800-1200L	82224	327.3

Lead time: 4 weeks

Flexco Impact Bed Light Duty 1500mm

(for impact zones with less than 25 Kg-m energy)

BELT WIDTH mm	ORDERING NUMBER	ITEM CODE	WT. KG.
600	EZIB600-1500L	82225	153.7
750	EZIB750-1500L	82226	161.3
900	EZIB900-1500L	82227	194.2
1050	EZIB1050-1500L	82228	229.7
1200	EZIB1200-1500L	82229	262.8
1350	EZIB1350-1500L	82230	298.8
1500	EZIB1500-1500L	82231	331.1
1800	EZIB1800-1500L	82232	366.8

Lead time: 4 weeks

Product Notes:

- No need to specify troughing angle—designed to adjust to 20°, 35°, 45°.
- Outermost trough bar features 25mm solid UHMW slider bar to provide longer wear life and consistent load zone sealing where impact is not present.

Replacement Parts List

EZIB-L
Flexco® Impact Beds
All Bars - Light Duty

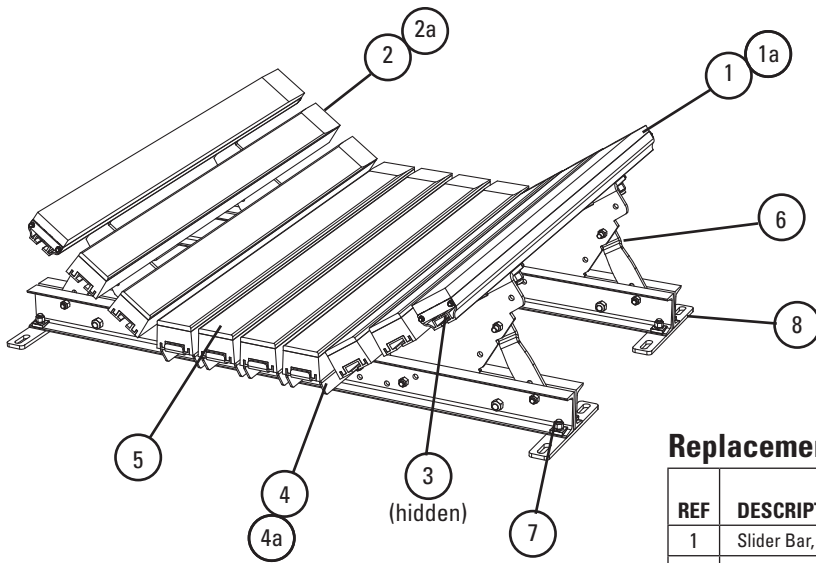

Replacement Parts

REF	DESCRIPTION	ORDERING NUMBER	ITEM CODE	WT. KG.
1	Slider Bar, 1200mm	SB4	78789	9.1
1a	Slider Bar, 1500mm	SB5	78790	10.9
2	Impact Bar, 1200mm	IB4	76926	7.7
2a	Impact Bar, 1500mm	IB5	76927	9.5
3	Bar Bolt Kit (incl. 1 ea. 16mm carriage bolt, square washer, flat washer, lock washer, Nylock nut)	RIBBK	81250	0.2
4	Impact Bar Support - 1.2M*	EZBS-1200	82361	7.3
4a	Impact Bar Support - 1.5M*	EZBS-1500	82362	9.3
5	Centre Bar Mount Kit 600mm*	EZBMK-600	82281	2.4
	Centre Bar Mount Kit 750mm*	EZBMK-750	82282	2.6
	Centre Bar Mount Kit 900mm*	EZBMK-900	82283	3.4
	Centre Bar Mount Kit 1050mm*	EZBMK-1050	82284	3.6
	Centre Bar Mount Kit 1200mm*	EZBMK-1200	82285	4.4
	Centre Bar Mount Kit 1350mm*	EZBMK-1350	82286	4.8
	Centre Bar Mount Kit 1500mm*	EZBMK-1500	82287	5.6
	Centre Bar Mount Kit 1800mm*	EZBMK-1800	82288	6.6
6	Wing Plate Kit 600mm*	EZWPK-600	82345	7.7
	Wing Plate Kit 750mm*	EZWPK-750	82346	7.9
	Wing Plate Kit 900mm*	EZWPK-900	82347	9.6
	Wing Plate Kit 1050mm*	EZWPK-1050	82348	11.9
	Wing Plate Kit 1200mm*	EZWPK-1200	82349	13.7
	Wing Plate Kit 1350mm*	EZWPK-1350	82350	16.1
	Wing Plate Kit 1500mm*	EZWPK-1500	82351	17.7
	Wing Plate Kit 1800mm*	EZWPK-1800	82352	21.2
7	Cross Stringer Kit 600mm*	EZCSK-600	82353	22.3
	Cross Stringer Kit 750mm*	EZCSK-750	82354	25.6
	Cross Stringer Kit 900mm*	EZCSK-900	82355	28.9
	Cross Stringer Kit 1050mm*	EZCSK-1050	82356	32.1
	Cross Stringer Kit 1200mm*	EZCSK-1200	82357	35.6
	Cross Stringer Kit 1350mm*	EZCSK-1350	82358	38.9
	Cross Stringer Kit 1500mm*	EZCSK-1500	82359	42.2
	Cross Stringer Kit 1800mm*	EZCSK-1800	82360	45.0
8	Shim Kit Light Duty (incl. 4 shims)	SHIM-LDKIT	82393	6.2

*Hardware Included. Lead time: 4 weeks.

Replacement Quantities for EZIB-L

mm		600	750	900	1050	1200	1350	1500	1800
BARS REQUIRED	SLIDER	2	2	2	2	2	2	2	2
	IMPACT	4	4	5	7	8	10	11	12
BAR BOLT KITS REQUIRED		14	14	17	21	24	28	31	34
BAR SUPPORTS REQUIRED		2	2	3	3	4	4	5	6

Product Ordering Information

EZIB-M
Flexco® Impact Beds
All Bars - Medium Duty



Flexco® Impact Bed Medium Duty 1200mm

(for impact zones with 25-100 Kg-m energy)

BELT WIDTH mm	ORDERING NUMBER	ITEM CODE	WT. KG.
600	EZIB600-1200M	82233	185.7
750	EZIB750-1200M	82234	197.1
900	EZIB900-1200M	82235	214.7
1050	EZIB1050-1200M	82236	269.9
1200	EZIB1200-1200M	82237	305.2
1350	EZIB1350-1200M	82238	343.8
1500	EZIB1500-1200M	82239	361.1
1800	EZIB1800-1200M	82240	382.9

Lead time: 4 weeks

Flexco Impact Bed Medium Duty 1500mm

(for impact zones with 25-100 Kg-m energy)

BELT WIDTH mm	ORDERING NUMBER	ITEM CODE	WT. KG.
600	EZIB600-1500M	82241	205.3
750	EZIB750-1500M	82242	216.6
900	EZIB900-1500M	82243	234.3
1050	EZIB1050-1500M	82244	297.4
1200	EZIB1200-1500M	82245	336.7
1350	EZIB1350-1500M	82246	379.3
1500	EZIB1500-1500M	82247	396.6
1800	EZIB1800-1500M	82248	461.0

Lead time: 4 weeks

Product Notes:

- No need to specify troughing angle—designed to adjust to 20°, 35°, 45°.
- Outermost trough bar features 25mm solid UHMW slider bar to provide longer wear life and consistent load zone sealing where impact is not present.

Replacement Parts List

EZIB-M
Flexco® Impact Beds
 All Bars - Medium Duty

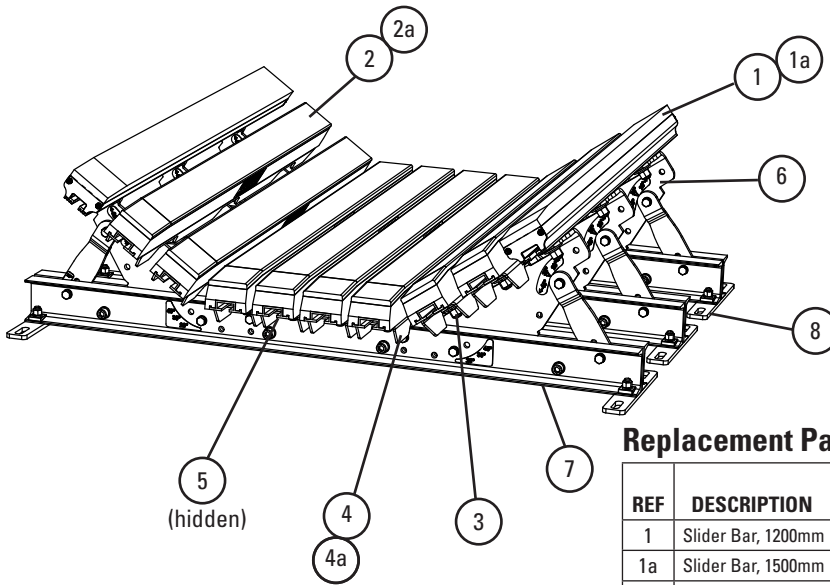

Replacement Parts

REF	DESCRIPTION	ORDERING NUMBER	ITEM CODE	WT. KG.
1	Slider Bar, 1200mm	SB4	78789	9.1
1a	Slider Bar, 1500mm	SB5	78790	10.9
2	Impact Bar, 1200mm	IB4	76926	7.7
2a	Impact Bar, 1500mm	IB5	76927	9.5
3	Bar Bolt Kit (incl. 1 ea. 16mm carriage bolt, square washer, flat washer, lock washer, Nylock nut)	RIBBK	81250	0.2
4	Impact Bar Support - 1200mm*	IBS-M1200	82397	7.7
4a	Impact Bar Support - 1500mm*	IBS-M1500	82398	9.6
5	Centre Bar Mount Kit 600mm*	EZBMK-600	82281	2.4
	Centre Bar Mount Kit 750mm*	EZBMK-750	82282	2.6
	Centre Bar Mount Kit 900mm*	EZBMK-900	82283	3.4
	Centre Bar Mount Kit 1050mm*	EZBMK-1050	82284	3.6
	Centre Bar Mount Kit 1200mm*	EZBMK-1200	82285	4.4
	Centre Bar Mount Kit 1350mm*	EZBMK-1350	82286	4.8
	Centre Bar Mount Kit 1500mm*	EZBMK-1500	82287	5.6
	Centre Bar Mount Kit 1800mm*	EZBMK-1800	82288	6.6
6	Wing Plate Kit 600mm*	EZWPK-600	82345	7.7
	Wing Plate Kit 750mm*	EZWPK-750	82346	7.9
	Wing Plate Kit 900mm*	EZWPK-900	82347	9.6
	Wing Plate Kit 1050mm*	EZWPK-1050	82348	11.9
	Wing Plate Kit 1200mm*	EZWPK-1200	82349	13.7
	Wing Plate Kit 1350mm*	EZWPK-1350	82350	16.1
	Wing Plate Kit 1500mm*	EZWPK-1500	82351	17.7
7	Wing Plate Kit 1800mm*	EZWPK-1800	82352	21.2
	Cross Stringer Kit 600mm*	EZCSK-600	82353	22.3
	Cross Stringer Kit 750mm*	EZCSK-750	82354	25.6
	Cross Stringer Kit 900mm*	EZCSK-900	82355	28.9
	Cross Stringer Kit 1050mm*	EZCSK-1050	82356	32.1
	Cross Stringer Kit 1200mm*	EZCSK-1200	82357	35.6
	Cross Stringer Kit 1350mm*	EZCSK-1350	82358	38.9
	Cross Stringer Kit 1500mm*	EZCSK-1500	82359	42.2
8	Shim Kit Medium Duty (incl. 4 shims)	SHIM-MDKIT	82394	9.3

*Hardware Included. Lead time: 4 weeks.

Replacement Quantities for EZIB-M

mm		600	750	900	1050	1200	1350	1500	1800
BARS REQUIRED	SLIDER	2	2	2	2	2	2	2	2
	IMPACT	4	4	5	7	8	10	11	12
BAR BOLT KITS REQUIRED		26	26	31	37	42	48	53	58
BAR SUPPORTS REQUIRED		4	4	5	5	6	6	7	8

It's the Structure, not the bars

It absorbs more impact to save your belt. Our exclusive Velocity Reduction Technology™ provides two levels of impact relief.

Level 1: **Impact Bars** first absorb impact energy. Unique Impact Bar Supports on all DRX™ Impact Beds allow the impact bars to function properly - expanding and absorbing more impact energy.

Level 2: On DRX200, 750 and 1500 impact beds, **Isolation Mounts** provide a second level of reaction force reduction, absorbing additional impact energy and minimising transmission back to the belt. The DRX3000 Dynamic has **Impact Energy Absorbers** to disperse an immense amount of impact, even in extremely severe applications.

User-Friendly Slide-Out Service™

- All DRX Impact Beds separate in the middle to slide apart and out.
- Can be easily and safely converted from the run position to the service position.
- Impact bars are easy to get to for changeout. A complete changeout can be done in one or two hours.

Unique Impact Bar Supports protect the impact bars from damage, extending service life. An Anti-Migratory Tab on each support secures the bar and prevents it from sliding in the direction of the belt.

Other Features and Benefits

- Uses exclusive anti-spin square washers. Allows use of carriage bolts to secure impact bars instead of expensive T bolts.
- Centre bars are tilted 3° inward to help centre the load on the belt.

How to spec the correct impact bed for your conveyor transfer point

Impact Energy Calculation Chart

Largest Material Lump Weight (w)

Drop Height (h)

ROLLER SIZE

127 mm 152 mm

Belt Width _____

Troughing Angle: 20° 35°

Bed Length: 1.2 M 1.5 M

IMPACT ENERGY

Lump Weight (w) _____

Drop Height (h) x _____

Total=kg/Mtr _____ See Below

Up to 25 kg-m—DRX200

25 to 100 kg-m—DRX750

100 to 200 kg-m—DRX1500

200 to 400 kg-m—DRX3000

) refer to (*) for specific lead time, if lead time applies.
) please contact Flexco for dispatch options and lead times.

Product Ordering Information

DRX™200
Impact Beds

DRX™200

1.2 M Beds, 20° Trough

BELT WIDTH mm	ORDERING NUMBER	ITEM CODE	WT. KG.
600	DRXL-24-420	76816	118.2
750	DRXL-30-420	76817	128.2
900	DRXL-36-420	76818	146.8
1050	DRXL-42-420	76819	187.3
1200	DRXL-48-420	76820	196.8
1350	DRXL-54-420	76821	226.4
1500	DRXL-60-420	76822	246.8
1800	DRXL-72-420	76823	279.6

DRX200

1.5 M Beds, 20° Trough

BELT WIDTH mm	ORDERING NUMBER	ITEM CODE	WT. KG.
600	DRXL-24-520	76824	131.8
750	DRXL-30-520	76825	141.4
900	DRXL-36-520	76826	162.3
1050	DRXL-42-520	76827	208.6
1200	DRXL-48-520	76828	218.2
1350	DRXL-54-520	76829	251.8
1500	DRXL-60-520	76830	273.6
1800	DRXL-72-520	76831	308.6

DRX200

1.2 M Beds, 35° Trough

BELT WIDTH mm	ORDERING NUMBER	ITEM CODE	WT. KG.
600	DRXL-24-435	76832	118.2
750	DRXL-30-435	76833	128.2
900	DRXL-36-435	76834	146.8
1050	DRXL-42-435	76835	187.3
1200	DRXL-48-435	76836	196.8
1350	DRXL-54-435	76837	226.4
1500	DRXL-60-435	76838	246.8
1800	DRXL-72-435	76839	279.6

DRX200

1.5 M Beds, 35° Trough

BELT WIDTH mm	ORDERING NUMBER	ITEM CODE	WT. KG.
600	DRXL-24-535	76840	131.8
750	DRXL-30-535	76841	141.4
900	DRXL-36-535	76842	162.3
1050	DRXL-42-535	76843	208.6
1200	DRXL-48-535	76844	218.2
1350	DRXL-54-535	76845	251.8
1500	DRXL-60-535	76846	273.6
1800	DRXL-72-535	76847	308.6

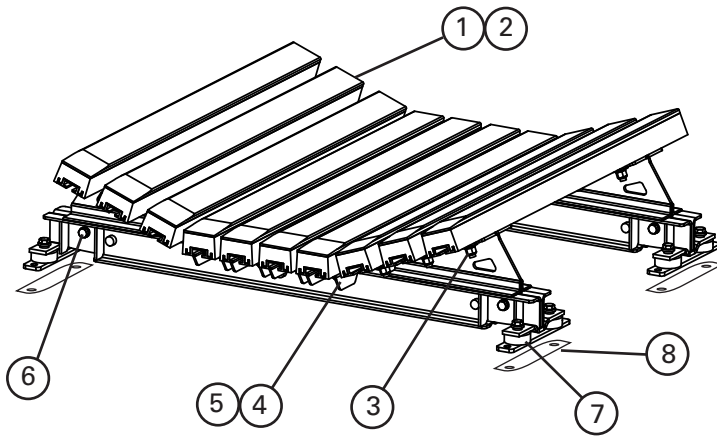

Replacement Bars and Bolt Kits Required per Belt Width-DRX200

BELT WIDTH mm	600	750	900	1050	1200	1350	1500	1800
Impact Bar Supports Required	2	2	3	4	4	4	5	6
Impact Bars Required	6	6	7	10	10	12	13	14
Impact Bar Bolt Kits Required	14	14	17	24	24	28	31	34

Replacement Parts

REF	DESCRIPTION	ORDERING NUMBER	ITEM CODE	WT. KG.
1	Impact Bar, 1.2 M	IB4	76926	7.7
2	Impact Bar, 1.5 M	IB5	76927	9.6
3	Impact Bar Bolt Kit incl. (1) ea 16 mm carriage bolt, square washer, flat washer, lock washer, Nylock nut	IBBK	76928	0.2
4	Impact Bar Support -L 1.2 M incl. (1) ea bar support, carriage bolt, square washer, lock washer, Nylock nut	IBS-L4	76929	7.6
5	Impact Bar Support -L 1.5 M incl. (1) ea bar support, carriage bolt, square washer, lock washer, Nylock nut	IBS-L5	76930	9.6
6	Sliding Support Arm Bolt Kit incl. (2) 50 mm bolts, (2) lock washers, (2) Nylock nuts	ISABK-LMH	77529	0.9
7	Isolation Mount Kit	IMK	76936	1.7
8	DRX200 Shim Kit (incl. 4 shims)	SHIM-KITL	77548	6.1

Stock items (non-shaded) refer to (*) for specific lead time, if not specified, standard lead time applies.

Non-stock items (shaded) please contact Flexco for dispatch options and lead times.

Product Ordering Information

DRX™750
Impact Beds

DRX™750

1.2 M Beds, 20° Trough

BELT WIDTH mm	ORDERING NUMBER	ITEM CODE	WT. KG.
600	DRXM-24-420	76848	165.9
750	DRXM-30-420	76849	180.5
900	DRXM-36-420	76850	212.3
1050	DRXM-42-420	76851	269.1
1200	DRXM-48-420	76852	283.2
1350	DRXM-54-420	76853	320.0
1500	DRXM-60-420	76854	354.1
1800	DRXM-72-420	76855	407.3

DRX750

1.5 M Beds, 20° Trough

BELT WIDTH mm	ORDERING NUMBER	ITEM CODE	WT. KG.
600	DRXM-24-520	76856	183.2
750	DRXM-30-520	76857	197.7
900	DRXM-36-520	76858	233.6
1050	DRXM-42-520	76859	298.2
1200	DRXM-48-520	76860	312.3
1350	DRXM-54-520	76861	353.2
1500	DRXM-60-520	76862	391.4
1800	DRXM-72-520	76863	447.7

DRX750

1.2 M Beds, 35° Trough

BELT WIDTH mm	ORDERING NUMBER	ITEM CODE	WT. KG.
600	DRXM-24-435	76864	165.9
750	DRXM-30-435	76865	180.5
900	DRXM-36-435	76866	212.3
1050	DRXM-42-435	76867	269.1
1200	DRXM-48-435	76868	283.2
1350	DRXM-54-435	76869	320.0
1500	DRXM-60-435	76870	354.1
1800	DRXM-72-435	76871	407.3

DRX750

1.5 M Beds, 35° Trough

BELT WIDTH mm	ORDERING NUMBER	ITEM CODE	WT. KG.
600	DRXM-24-535	76872	183.2
750	DRXM-30-535	76873	197.7
900	DRXM-36-535	76874	233.6
1050	DRXM-42-535	76875	298.2
1200	DRXM-48-535	76876	312.3
1350	DRXM-54-535	76877	353.2
1500	DRXM-60-535	76878	391.4
1800	DRXM-72-535	76879	447.7

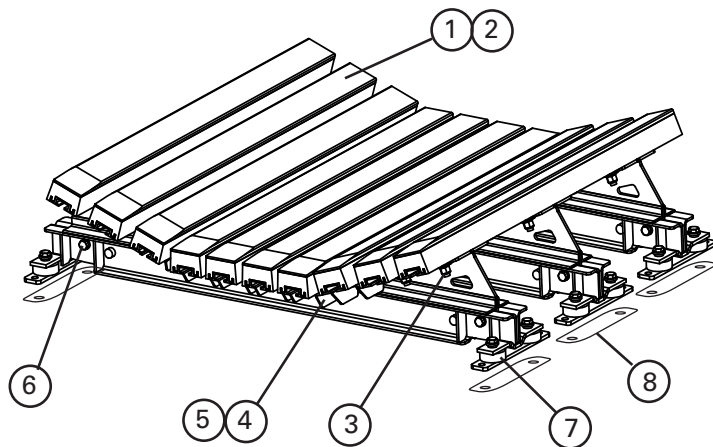

Replacement Bars and Bolt Kits Required per Belt Width-DRX750

BELT WIDTH mm	600	750	900	1050	1200	1350	1500	1800
Impact Bar Supports Required	4	4	5	6	6	6	7	8
Impact Bars Required	6	6	7	10	10	12	13	14
Impact Bar Bolt Kits Required	26	26	31	42	42	48	53	58

Replacement Parts

REF	DESCRIPTION	ORDERING NUMBER	ITEM CODE	WT. KG.
1	Impact Bar, 1.2 M	IB4	76926	7.7
2	Impact Bar, 1.5 M	IB5	76927	9.6
3	Impact Bar Bolt Kit incl. (1) ea 16 mm carriage bolt, square washer, flat washer, lock washer, Nylock nut	IBBK	76928	0.2
4	Impact Bar Support -M 1.2 M incl. (1) bar support, (2) ea carriage bolt, square washer, lock washer, Nylock nut	IBS-M4	76931	7.7
5	Impact Bar Support -M 1.5 M incl. (1) bar support, (2) ea carriage bolt, square washer, lock washer, Nylock nut	IBS-M5	76932	9.6
6	Sliding Support Arm Bolt Kit incl. (2) 50 mm bolts, (2) lock washers, (2) Nylock nuts	ISABK-LMH	77529	0.9
7	Isolation Mount Kit	IMK	76936	1.7
8	DRX750 Shim Kit (incl. 6 shims)	SHIM-KITM	77549	9.3

Stock items (non-shaded) refer to (*) for specific lead time, if not specified, standard lead time applies.

Non-stock items (shaded) please contact Flexco for dispatch options and lead times.

Product Ordering Information

DRX™ 1500
Impact Beds

DRX™1500

1.2 M Beds, 20° Trough

BELT WIDTH mm	ORDERING NUMBER	ITEM CODE	WT. KG.
600	DRXH-24-420	76880	228.6
750	DRXH-30-420	76881	247.7
900	DRXH-36-420	76882	285.5
1050	DRXH-42-420	76883	366.4
1200	DRXH-48-420	76884	385.0
1350	DRXH-54-420	76885	444.1
1500	DRXH-60-420	76886	484.6
1800	DRXH-72-420	76887	550.0

DRX1500

1.5 M Beds, 20° Trough

BELT WIDTH mm	ORDERING NUMBER	ITEM CODE	WT. KG.
600	DRXH-24-520	76888	253.6
750	DRXH-30-520	76889	273.2
900	DRXH-36-520	76890	314.6
1050	DRXH-42-520	76891	407.3
1200	DRXH-48-520	76892	425.9
1350	DRXH-54-520	76893	492.7
1500	DRXH-60-520	76894	536.8
1800	DRXH-72-520	76895	606.4

DRX1500

1.2 M Beds, 35° Trough

BELT WIDTH mm	ORDERING NUMBER	ITEM CODE	WT. KG.
600	DRXH-24-435	76896	228.6
750	DRXH-30-435	76897	247.7
900	DRXH-36-435	76898	285.5
1050	DRXH-42-435	76899	366.4
1200	DRXH-48-435	76900	385.0
1350	DRXH-54-435	76901	444.1
1500	DRXH-60-435	76902	484.6
1800	DRXH-72-435	76903	550.0

DRX1500

1.5 M Beds, 35° Trough

BELT WIDTH mm	ORDERING NUMBER	ITEM CODE	WT. KG.
600	DRXH-24-535	76904	253.6
750	DRXH-30-535	76905	273.2
900	DRXH-36-535	76906	314.6
1050	DRXH-42-535	76907	407.3
1200	DRXH-48-535	76908	425.9
1350	DRXH-54-535	76909	492.7
1500	DRXH-60-535	76910	536.8
1800	DRXH-72-535	76911	606.4

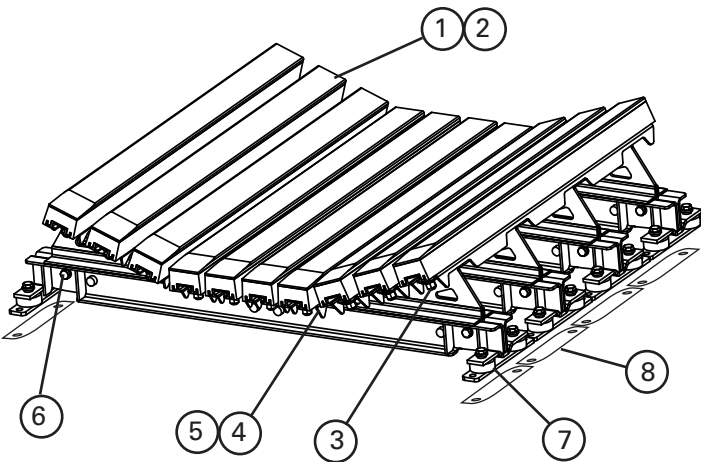

Replacement Parts

REF	DESCRIPTION	ORDERING NUMBER	ITEM CODE	WT. KG.
1	Impact Bar, 1.2 M	IB4	76926	7.7
2	Impact Bar, 1.5 M	IB5	76927	9.6
3	Impact Bar Bolt Kit incl. (1) ea 16 mm carriage bolt, square washer, flat washer, lock washer, Nylock nut	IBBK	76928	0.2
4	Impact Bar Support -H 1.2 M incl. (1) bar support, (2) ea carriage bolt, square washer, lock washer, Nylock nut	IBS-H4	76933	7.6
5	Impact Bar Support -DH 1.5 M incl. (1) bar support, (2) ea carriage bolt, square washer, lock washer, Nylock nut	IBS-DH5	76934	9.6
6	Sliding Support Arm Bolt Kit incl. (2) 50 mm bolts, (2) lock washers, (2) Nylock nuts	ISABK-LMH	77529	0.9
7	Isolation Mount Kit	IMK	76936	1.7
8	DRX1500 Shim Kit (incl. 8 shims)	SHIM-KITH	77550	12.3

Replacement Bars and Bolt Kits Required per Belt Width-DRX1500

BELT WIDTH mm	600	750	900	1050	1200	1350	1500	1800
Impact Bar Supports Required	6	6	7	10	10	12	13	14
Impact Bars Required	6	6	7	10	10	12	13	14
Impact Bar Bolt Kits Required	36	36	42	60	60	72	78	84

Stock items (non-shaded) refer to (*) for specific lead time, if not specified, standard lead time applies.

Non-stock items (shaded) please contact Flexco for dispatch options and lead times.

Product Ordering Information

DRX™3000
Dynamic Beds

DRX™3000

1.5 M Beds, 20° Trough

BELT WIDTH mm	ORDERING NUMBER	ITEM CODE	WT. KG.
1050	DRXD-42-520	76912	614.1
1200	DRXD-48-520	76913	639.6
1350	DRXD-54-520	76914	712.7
1500	DRXD-60-520	76915	761.8
1800	DRXD-72-520	76916	953.6
2100	DRXD-84-520	76917	1027.7
2400	DRXD-96-520	76918	1185.9

DRX3000

1.5 M Beds, 35° Trough

BELT WIDTH mm	ORDERING NUMBER	ITEM CODE	WT. KG.
1050	DRXD-42-535	76919	614.1
1200	DRXD-48-535	76920	639.6
1350	DRXD-54-535	76921	712.7
1500	DRXD-60-535	76922	761.8
1800	DRXD-72-535	76923	953.6
2100	DRXD-84-535	76924	1027.7
2400	DRXD-96-535	76925	1185.9

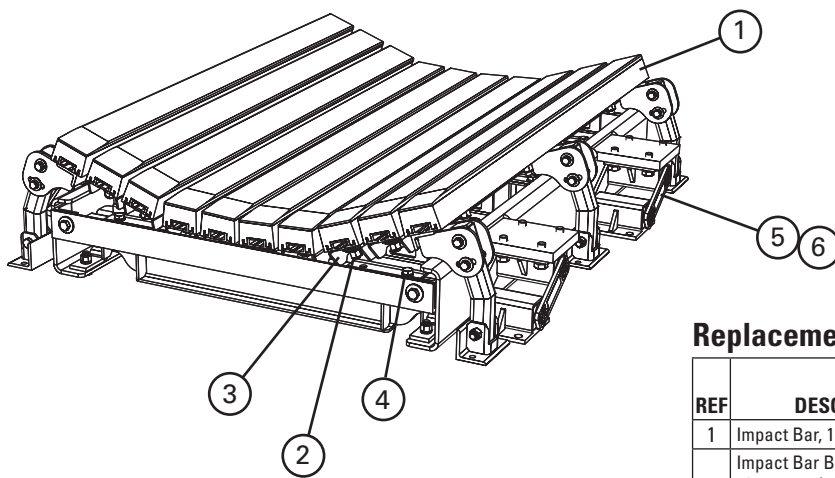

Replacement Bars and Bolt Kits Required per Belt Width-DRX3000

BELT WIDTH mm	1050	1200	1350	1500	1800	2100	2400
Impact Bars Required	10	10	12	13	16	16	20
Impact Bar Bolt Kits Required	56	56	64	70	88	88	112

Replacement Parts

REF	DESCRIPTION	ORDERING NUMBER	ITEM CODE	WT. KG.
1	Impact Bar, 1.5 M	IB5	76927	9.6
2	Impact Bar Bolt Kit incl. (1) ea 16 mm carriage bolt, square washer, flat washer, lock washer, Nylock nut	IBBK	76928	0.2
3	Impact Bar Support - DH 1.5 M incl. (1) bar support, (2) ea carriage bolt, square washer, lock washer, Nylock nut	IBS-DH5	76934	9.6
4	Sliding Support Arm Bolt Kit incl. (4) 38 mm bolts, (2) 51 mm bolts, (6) lock washers, (6) Nylock nuts	ISABK	76935	0.9
5	Impact Energy Absorber 42-60	IEA42-60D	76937	19.1
6	Impact Energy Absorber 72-96	IEA72-96D	76938	30.0

Impact Bar Supports per Belt Width

BELT WIDTH mm	1050	1200	1350	1500	1800	2100	2400
Impact Bar Supports	8	8	8	9	12	12	16

Product Notes:

- For extreme impact applications up to 400 kgs.-M (lump size x drop height).
- Impact Energy Absorbers compress up to 75 mm to absorb extreme impact energy to minimize damaging forces and protect the belt.
- Slide-Out System™ allows direct access to service the impact bars.

Stock items (non-shaded) refer to (*) for specific lead time, if not specified, standard lead time applies.

Non-stock items (shaded) please contact Flexco for dispatch options and lead times.

Product Ordering Information

DRX™ Impact Beds Optional Parts and Tools

Impact Bars with 25 mm UHMW

For impact beds that have heavy abrasive wear on the impact bars.

DESCRIPTION	ORDERING NUMBER	ITEM CODE	WT. KG.
1.2 M Impact Bar with 25 mm UHMW	IB4-1U	76965	7.7
1.5 M Impact Bar with 25 mm UHMW	IB5-1U	76966	9.6

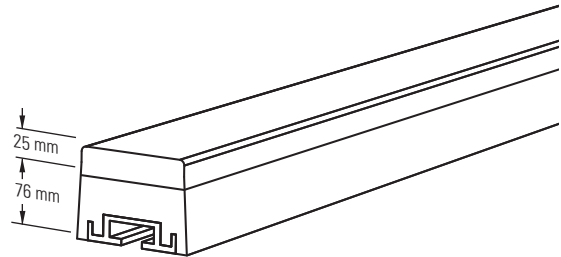

Impact Bar with 25 mm UHMW Cover

Impact Bar Bolt Kit for Other OEM Impact Beds*

13 mm carriage bolts, square washer, flat washer and Nylock nut to mount DRX Impact Bars on other OEM beds that use 13 mm T-bolts.

DESCRIPTION	ORDERING NUMBER	ITEM CODE	WT. KG.
Optional Impact Bar Bolt Kit	OIBBK	76950	0.2

*Kit includes 1 ea. bolt, square washer, flat washer and nut.



Optional Impact Bar Bolt Kit

Impact Bed Handy Wrench

A ratcheting wrench with 2 common socket sizes 19 mm & 24 mm for installation and maintenance of impact beds.

DESCRIPTION	ORDERING NUMBER	ITEM CODE	WT. KG.
Impact Bed Handy Wrench	HW-IMPB	76939	0.7

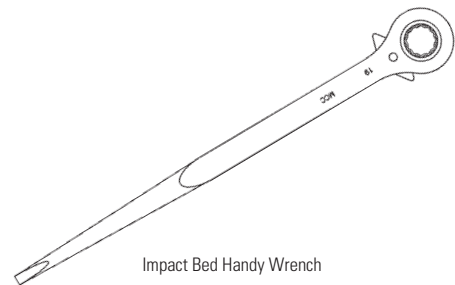

Impact Bed Handy Wrench

 **Stock items** (non-shaded) refer to (*) for specific lead time, if not specified, standard lead time applies.

 **Non-stock items** (shaded) please contact Flexco for dispatch options and lead times.

Product Ordering Information

V-Plough



U.S. Model pictured

Deflector™ V Plough-Mild Steel

BELT WIDTH mm	ORDERING NUMBER	ITEM CODE	WT. KG.
450	BP450	73102	23
600	BP600	73104	25
750	BP750	73106	26
800	BP800	73107	28
900	BP900	73108	29
1050	BP1050	73110	31
1200	BP1200	73112	38
1400	BP1400	73113	42
1500	BP1500	73114	43
1600	BP1600	73115	44
1800	BP1800	73117	65

Note: Polyurethane Blades are approved for use in underground mines.
For belt widths over 1800 mm contact Flexco®.

Deflector™ V Plough-Stainless Steel

BELT WIDTH mm	ORDERING NUMBER	ITEM CODE	WT. KG.
450	BP450-S/S	76337	24
600	BP600-S/S	76338	25
750	BP750-S/S	76339	27
800	BP800-S/S	76340	29
900	BP900-S/S	76341	30
1050	BP1050-S/S	76342	32
1200	BP1200-S/S	76343	39
1400	BP1400-S/S	76344	44
1500	BP1500-S/S	76345	45
1600	BP1600-S/S	76346	46
1800	BP1800-S/S	76347	67

Note: Polyurethane Blades are approved for use in underground mines.
For belt widths over 1800 mm contact Flexco.

Replacement Parts-Mild Steel

DESCRIPTION	ORDERING NUMBER	ITEM CODE	WT. KG.
Pole	BP450-750-PL	73109	2.7
	BP800-1050-PL	73111	3.2
	BP1200-1400-PL	73118	3.6
	BP1500-1600-PL	73119	4.6
	BP1800-PL	73121	5.5
Mounting Bracket	BP-MB	73123	0.5
Shaft Collar	BP-SC	73125	0.5
Linkage Arm	BP-LA	73127	0.9
Turnbuckle Linkage	BP-TL	73141	0.5

Product Notes:

- Exclusive blade design - 20° slant on leading edge spirals debris off the belt.
- Self-adjusting blade - the blade floats on the belt and self-adjusts as it wears.
- Unique blade adjuster - turnbuckle-type adjuster allows the blade to be accurately positioned to the belt.
- Easy to install - comes fully assembled and can be placed right into position on the conveyor.

Replacement Blades

Polyurethane-pair 110mm

BELT WIDTH mm	ORDERING NUMBER	ITEM CODE	WT. KG.
450	BP450-B	74055	0.9
600	BP600-B	73777	0.9
750	BP750-B	73778	1.8
800	BP800-B	74057	1.8
900	BP900-B	73779	1.8
1050	BP1050-B	73780	1.8
1200	BP1200-B	73781	1.8
1400	BP1400-B	73782	2.3
1500	BP1500-B	73783	2.3
1600	BP1600-B	73784	2.7
1800	BP1800-B	73785	3.2

Note: Polyurethane Blades are approved for use in underground mines

Heavy-Duty Replacement Blades

Polyurethane-pair 180mm

BELT WIDTH mm	ORDERING NUMBER	ITEM CODE	WT. KG.
750	BP750-HD-B	A0223	1.8
900	BP900-HD-B	A0224	1.8
1050	BP1050-HD-B	A2237	1.8
1200	BP1200-HD-B	73301	1.8
1400	BP1400-HD-B	73302	2.3
1500	BP1500-HD-B	73303	2.3
1600	BP1600-HD-B	73304	2.7
1800	BP1800-HD-B	73306	3.2
2000	BP2000-HD-B	73307	3.5
2200	BP2200-HD-B	73308	3.9
2400	BP2400-HD-B	73309	4.2
2500	BP2500-HD-B	73311	4.2

Note: Polyurethane Blades are approved for use in underground mines

Replacement Parts-Stainless Steel

DESCRIPTION	ORDERING NUMBER	ITEM CODE	WT. KG.
Pole	BP450-750-PL-S/S	A0683	2.7
	BP800-1050-PL-S/S	A0613	3.2
	BP1200-1400-PL-S/S	A0621	3.6
	BP1500-1600-PL-S/S	A0647	5.0
	BP1800-PL-S/S	A1547	5.9
Mounting Bracket	BP-MB-S/S	A0615	0.5
Shaft Collar	BP-SC-S/S	A0616	0.5
Linkage Arm	BP-LA-S/S	A0614	0.9
Standard Turnbuckle	BP-TB	73138	0.5
Standard U-Bolt	BP-UB	73139	0.5
Turnbuckle Linkage	BP-TL-S/S	A0617	0.5

Stock items (non-shaded) refer to (*) for specific lead time, if not specified, standard lead time applies.

Non-stock items (shaded) please contact Flexco for dispatch options and lead times.

Product Ordering Information

Twin Pole V-Plough



Deflector™ Twin Pole V Plough-Mild Steel UHMPE Blade

BELT WIDTH mm	ORDERING NUMBER	ITEM CODE	WT. KG.
900	HBP900-TP	A2283	93.0
1050	HBP1050-TP	A2284	99.0
1200	HBP1200-TP	A2285	106.0
1400	HBP1400-TP	A2286	115.0
1500	HBP1500-TP	A2287	119.0
1600	HBP1600-TP	A2288	124.0
1800	HBP1800-TP	A2289	133.0
2000	HBP2000-TP	A2290	142.0
2200	HBP2200-TP	A2291	151.0
2400	HBP2400-TP	A2292	162.0
2500	HBP2500-TP	A2293	165.0

Note: Scraping blades are UHMPE material.
Blades are not FRAS approved.
For belt widths over 2500 mm contact Flexco®.
Lead time: 3 weeks

Deflector™ Twin Pole V Plough-Stainless Steel UHMPE Blade

BELT WIDTH mm	ORDERING NUMBER	ITEM CODE	WT. KG.
900	HBP-TP-900 S/S	A2474	94.0
1050	HBP-TP-1050 S/S	A2475	100.0
1200	HBP-TP-1200 S/S	A2476	107.0
1400	HBP-TP-1400 S/S	A2477	116.0
1500	HBP-TP-1500 S/S	A2478	120.0
1600	HBP-TP-1600 S/S	A2479	125.0
1800	HBP-TP-1800 S/S	A2480	134.0
2000	HBP-TP-2000 S/S	A2481	143.0
2200	HBP-TP-2200 S/S	A2482	152.0
2400	HBP-TP-2400 S/S	A2483	163.0
2500	HBP-TP-2500 S/S	A2484	166.0

Note: Scraping blades are UHMPE material.
Blades are not FRAS approved.
For belt widths over 2500 mm contact Flexco.
Lead time: 3 weeks

Stock items (non-shaded) refer to (*) for specific lead time, if not specified, standard lead time applies.

Non-stock items (shaded) please contact Flexco for dispatch options and lead times.

Replacement Parts List

Twin Pole V-Plough

Replacement Parts		POWDER COATED			STAINLESS STEEL		
DESCRIPTION	BELT WIDTH mm	ORDERING NUMBER	ITEM CODE	WT. KG.	ORDERING NUMBER	ITEM CODE	WT. KG.
PL Pole	900	HBP900-PL-TP	A2294	14.0	HBP900-PL-TP-S/S	A2492	15.0
	1050	HBP1050-PL-TP	A2295	15.0	HBP1050-PL-TP-S/S	A2493	16.0
	1200	HBP1200-PL-TP	A2296	16.0	HBP1200-PL-TP-S/S	A2494	17.0
	1400	HBP1400-PL-TP	A2297	18.0	HBP1400-PL-TP-S/S	A2495	19.0
	1500	HBP1500-PL-TP	A2298	20.0	HBP1500-PL-TP-S/S	A2496	21.0
	1600	HBP1600-PL-TP	A2299	21.0	HBP1600-PL-TP-S/S	A2497	22.0
	1800	HBP1800-PL-TP	A2300	22.0	HBP1800-PL-TP-S/S	A2498	23.0
	2000	HBP2000-PL-TP	A2301	24.0	HBP2000-PL-TP-S/S	A2499	25.0
	2200	HBP2200-PL-TP	A2303	26.0	HBP2200-PL-TP-S/S	A2500	27.0
	2400	HBP2400-PL-TP	A2302	28.0	HBP2400-PL-TP-S/S	A2501	29.0
	2500	HBP2500-PL-TP	A2304	29.0	HBP2500-PL-TP-S/S	A2502	30.0
Frame	900	HBP900-MF-TP	A2305	26.0	HBP900-MF-TP-S/S	A2504	27.0
	1050	HBP1050-MF-TP	A2306	28.0	HBP1050-MF-TP-S/S	A2505	29.0
	1200	HBP1200-MF-TP	A2307	30.0	HBP1200-MF-TP-S/S	A2506	31.0
	1400	HBP1400-MF-TP	A2308	33.0	HBP1400-MF-TP-S/S	A2507	34.0
	1500	HBP1500-MF-TP	A2309	34.0	HBP1500-MF-TP-S/S	A2508	35.0
	1600	HBP1600-MF-TP	A2310	35.5	HBP1600-MF-TP-S/S	A2509	36.5
	1800	HBP1800-MF-TP	A2311	38.0	HBP1800-MF-TP-S/S	A2510	39.0
	2000	HBP2000-MF-TP	A2312	41.0	HBP2000-MF-TP-S/S	A2511	42.0
	2200	HBP2200-MF-TP	A2314	44.0	HBP2200-MF-TP-S/S	A2512	45.0
	2400	HBP2400-MF-TP	A2313	52.0	HBP2400-MF-TP-S/S	A2513	53.0
	2500	HBP2500-MF-TP	A2315	54.0	HBP2500-MF-TP-S/S	A2514	55.0
Blades	900	HBP900-B-TP	A2316	4.5			
	1050	HBP1050-B-TP	A2317	5.0			
	1200	HBP1200-B-TP	A2318	5.5			
	1400	HBP1400-B-TP	A2319	6.3			
	1500	HBP1500-B-TP	A2320	7.0			
	1600	HBP1600-B-TP	A2321	7.5			
	1800	HBP1800-B-TP	A2322	8.2			
	2000	HBP2000-B-TP	A2323	9.0			
	2200	HBP2200-B-TP	A2325	9.8			
	2400	HBP2400-B-TP	A2324	10.7			
2500	HBP2500-B-TP	A2326	11.2				
Linkage Arm	900-2500	HBP-LA-TP	A2330	5.0	HBP-LA-TP-S/S	A2515	5.0
Mounting Bracket	900-2500	HBP-MB-TP	73922	2.1	HBP-MB-TP-S/S	A1155	2.1
Shaft Collar	900-2500	HBP-SC-TP	74490	0.7	HBP-SC-TP-S/S	A2189	0.7

Lead time: 3 weeks

Stock items (non-shaded) refer to (*) for specific lead time, if not specified, standard lead time applies.

Non-stock items (shaded) please contact Flexco for dispatch options and lead times.

Product Ordering Information

HD® Floating V-Plough



HD® Floating V Plough-Mild Steel UHMPE Blade

BELT WIDTH mm	ORDERING NUMBER	ITEM CODE	WT. KG.
900	FBP900-TP	61750	133
1050	FBP1050-TP	61751	137
1200	FBP1200-TP	61752	163
1400	FBP1400-TP	61753	167
1500	FBP1500-TP	61754	189
1600	FBP1600-TP	61755	192
1800	FBP1800-TP	61756	218
2000	FBP2000-TP	61757	224
2200	FBP2200-TP	61758	256
2400	FBP2400-TP	61759	261
2500	FBP2500-TP	61760	284
2600	FBP2600-TP	61761	287

Note: Scraping blades are UHMPE material. Blades are not FRAS approved. For belt widths over 2600 mm contact Flexco®. Lead time: 3 weeks

HD Floating V Plough Stainless Steel UHMPE Blade

BELT WIDTH mm	ORDERING NUMBER	ITEM CODE	WT. KG.
900	FBP900-TP S/S	61765	135
1050	FBP1050-TP S/S	61766	141
1200	FBP1200-TP S/S	61767	167
1400	FBP1400-TP S/S	61768	171
1500	FBP1500-TP S/S	61769	194
1600	FBP1600-TP S/S	61770	197
1800	FBP1800-TP S/S	61771	224
2000	FBP2000-TP S/S	61772	230
2200	FBP2200-TP S/S	61773	263
2400	FBP2400-TP S/S	61774	268
2500	FBP2500-TP S/S	61775	291
2600	FBP2600-TP S/S	61776	294

Note: Scraping blades are UHMPE material. Blades are not FRAS approved. For belt widths over 2600 mm contact Flexco. Lead time: 3 weeks

Replacement Blades

UHMPE - pair

BELT WIDTH mm	ORDERING NUMBER	ITEM CODE	WT. KG.
900	FBP900-B	61780	11.0
1050	FBP1050-B	61781	12.6
1200	FBP1200-B	61782	14.3
1400	FBP1400-B	61783	16.4
1500	FBP1500-B	61784	17.5
1600	FBP1600-B	61785	18.5
1800	FBP1800-B	61786	20.5
2000	FBP2000-B	61787	22.6
2200	FBP2200-B	61788	24.6
2400	FBP2400-B	61789	26.7
2500	FBP2500-B	61790	28.3
2600	FBP2600-B	61791	29.8

Lead time: 3 weeks

Product Notes:

- Cleans the inside/clean side of the return belt.
- Eliminates conveyor damage and belt mistracking caused by debris lodging in the tail pulley or take-up.
- Floating design self-adjusts as blade wears, eliminating the need for manual adjustment.
- Available in a range of sizes for multiple belt widths.
- Removes carryback on both sides of the conveyor
- UHMWPE blades provide long life and easy change-out.

Stock items (non-shaded) refer to (*) for specific lead time, if not specified, standard lead time applies.

Non-stock items (shaded) please contact Flexco for dispatch options and lead times.

Replacement Parts List

HD® Floating V-Plough

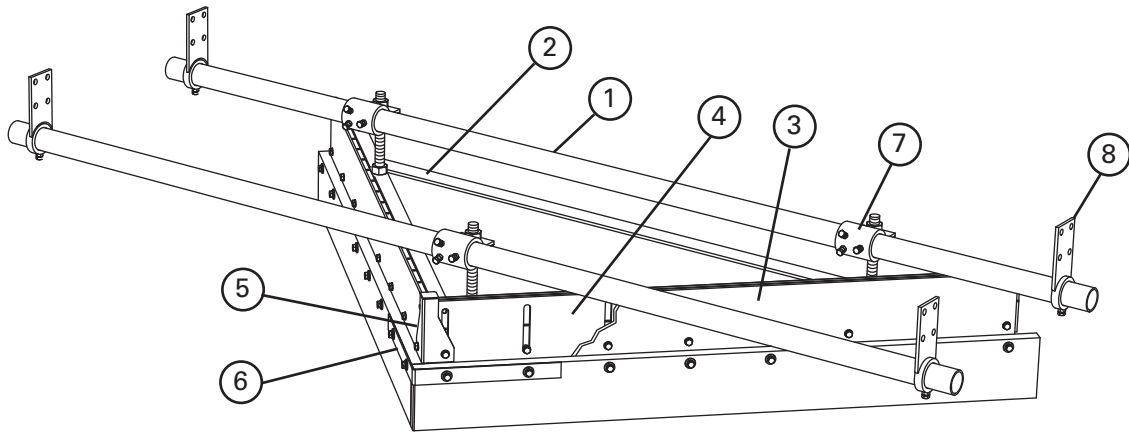

Replacement Parts

REF	DESCRIPTION	BELT WIDTH mm	MILD STEEL			STAINLESS STEEL		
			ORDERING NUMBER	ITEM CODE	WT. KG.	ORDERING NUMBER	ITEM CODE	WT. KG.
1	Pole	900	HBP900-PL-TP	A2294		HBP900-PL-TP-S/S	A2492	
		1050	HBP1050-PL-TP	A2295		HBP1050-PL-TP-S/S	A2493	
		1200	HBP1200-PL-TP	A2296		HBP1200-PL-TP-S/S	A2494	
		1400	HBP1400-PL-TP	A2297		HBP1400-PL-TP-S/S	A2495	
		1500	HBP1500-PL-TP	A2298		HBP1500-PL-TP-S/S	A2496	
		1600	HBP1600-PL-TP	A2299		HBP1600-PL-TP-S/S	A2497	
		1800	HBP1800-PL-TP	A2300		HBP1800-PL-TP-S/S	A2498	
		2000	HBP2000-PL-TP	A2301		HBP2000-PL-TP-S/S	A2499	
		2200	HBP2200-PL-TP	A2303		HBP2200-PL-TP-S/S	A2500	
		2400	HBP2400-PL-TP	A2302		HBP2400-PL-TP-S/S	A2501	
		2500	HBP2500-PL-TP	A2304		HBP2500-PL-TP-S/S	A2502	
		2600	HBP2600-PL-TP	A0151		HBP2600-PL-TP-S/S	61877	
2	Frame	900-1050	FBP900-1050-MF	61795		FBP900-1050-MF-S/S	61803	
		1200-1400	FBP1200-1400-MF	61796		FBP1200-1400-MF-S/S	61804	
		1500-1600	FBP1500-1600-MF	61797		FBP1500-1600-MF-S/S	61805	
		1800-2000	FBP1800-2000-MF	61798		FBP1800-2000-MF-S/S	61806	
		2200-2400	FBP2200-2400-MF	61799		FBP2200-2400-MF-S/S	61807	
		2500-2600	FBP2500-2600-MF	61800		FBP2500-2600-MF-S/S	61808	
3	Protection Plate Kit	900-1050	FBP900-1050-PP	61890		FBP900-1050-PP-S/S	61898	
		1200-1400	FBP1200-1400-PP	61891		FBP1200-1400-PP-S/S	61899	
		1500-1600	FBP1500-1600-PP	61892		FBP1500-1600-PP-S/S	61900	
		1800-2000	FBP1800-2000-PP	61893		FBP1800-2000-PP-S/S	61901	
		2200-2400	FBP2200-2400-PP	61894		FBP2200-2400-PP-S/S	61902	
4	Slotted Plate Kit	2500-2600	FBP2500-2600-PP	61895		FBP2500-2600-PP-S/S	61903	
		900-1050	FBP900-1050-SP	61906		FBP900-1050-SP-S/S	61914	
		1200-1400	FBP1200-1400-SP	61907		FBP1200-1400-SP-S/S	61915	
		1500-1600	FBP1500-1600-SP	61908		FBP1500-1600-SP-S/S	61916	
		1800-2000	FBP1800-2000-SP	61909		FBP1800-2000-SP-S/S	61917	
		2200-2400	FBP2200-2400-SP	61910		FBP2200-2400-SP-S/S	61918	
		2500-2600	FBP2500-2600-SP	61911		FBP2500-2600-SP-S/S	61919	
5	Nose Protection	All	FBP-NP	61875		FBP-NP-S/S	61876	
6	Faceplate	All	FBP-FP	61888		FBP-FP-S/S	61889	
7	Linkage Mount Kit	All	FBP-LM	61882		FBP-LM-S/S	61883	
8	Mounting Bracket	All	HBP-MB-TP	73922		HBP-MB-TP-S/S	A1155	

Lead time: 3 weeks

Stock items (non-shaded) refer to (*) for specific lead time, if not specified, standard lead time applies.

Non-stock items (shaded) please contact Flexco for dispatch options and lead times.

Product Ordering Information

Diagonal Plough

Diagonal Ploughs - Mild Steel*

BELT WIDTH mm	ORDERING NUMBER	ITEM CODE	WT. KG.
450-750	CBD-S	76442	20.0
900-1050	CBD-M	76443	25.0
1200-1500	CBD-L	76444	32.0
1600-1800	CBD-XL	76445	43.0
2000-2400	CBD-XXL	64787	54.0

*Use next larger size for Belt Widths between ranges.



Diagonal Plough* - Stainless Steel*

BELT WIDTH mm	ORDERING NUMBER	ITEM CODE	WT. KG.
450-750	CBD-S-S/S	64178	20.0
900-1050	CBD-M-S/S	A1854	25.0
1200-1500	CBD-L-S/S	A1856	32.0
1600-1800	CBD-XL-S/S	76318	43.0
2000-2400	CBD-XXL-S/S	63554	54.0

*Use next larger size for Belt Widths between ranges.

Replacement Blade Kits-Polyurethane Blades

BELT WIDTH mm	ORDERING NUMBER	ITEM CODE	WT. KG.
450-750	DBK-S	76446	2.0
900-1050	DBK-M	76447	3.0
1200-1500	DBK-L	76448	4.0
1600-2000	DBK-XL	76449	5.0

Kit includes blade and replacement blade bolts.

Diagonal Plough requires 1 blade; Reversing Plough requires 2 blades.

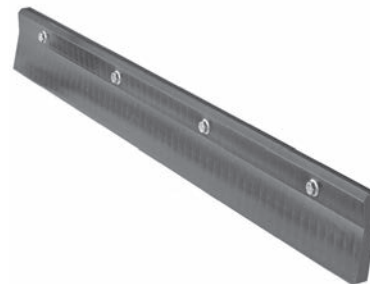

Deflector™ Reversible Plough with Polyurethane Blades-Mild Steel

BELT WIDTH mm	ORDERING NUMBER	ITEM CODE	WT. KG.
450-750	CBR-S	72483	40.0
900-1050	CBR-M	72484	48.0
1200-1500	CBR-L	72485	60.0
1600-2000	CBR-XL	72486	80.0



Product Notes:

- A belt cleaner for the tail pulley. Prevents damage to the belt, pulley, lagging, and belt splice.
- Keeps fugitive materials off the inside of the belt and out of the tail pulley.
- Installed at a 45° angle across the belt to discharge material to one predetermined side.
- The blade is installed in a fixed position, eliminating any bouncing problems.
- Exclusive 20° angled blade quickly spirals material off the belt.

 Stock items (non-shaded) refer to (*) for specific lead time, if not specified, standard lead time applies.

 Non-stock items (shaded) please contact Flexco for dispatch options and lead times.

Product Ordering Information & Replacement Parts

Diagonal Plough HD® Spring Tensioned

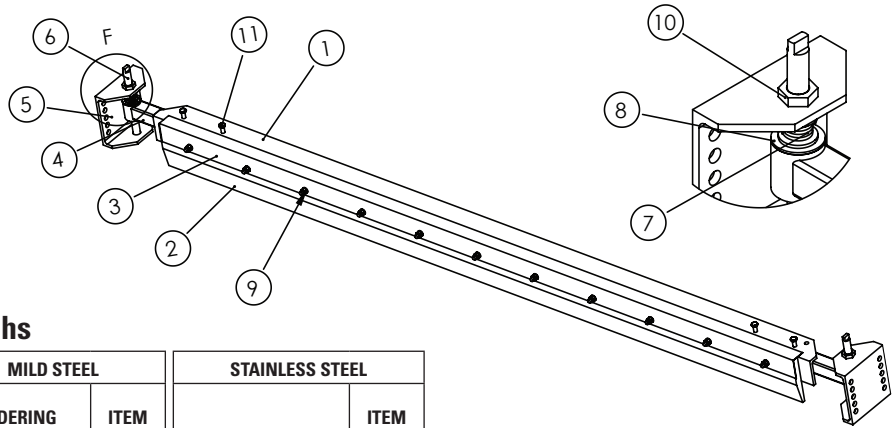

HD® Spring Tensioned Diagonal Ploughs

DESCRIPTION	BELT WIDTH mm	MILD STEEL		STAINLESS STEEL	
		ORDERING NUMBER	ITEM CODE	ORDERING NUMBER	ITEM CODE
Heavy-Duty Spring Tensioned Diagonal Plough	900-1050	CBD-ST-M	61077	CBD-ST-M-S/S	61079
	1200-1500	CBD-ST-L	61050	CBD-ST-L-S/S	61080
	1600-1800	CBD-ST-XL	61051	CBD-ST-XL-S/S	A2138
	2000-2400	CBD-ST-XXL	63747	CBD-ST-XXL-S/S	63748
Heavy-Duty Spring Tensioned Diagonal Plough with Polyurethane Blade	900-1050	CBD-ST-M-P	64772	CBD-ST-M-P-S/S	64623
	1200-1500	CBD-ST-L-P	64773	CBD-ST-L-P-S/S	64624
	1600-1800	CBD-ST-XL-P	64774	CBD-ST-XL-P-S/S	64625
Heavy-Duty Spring Tensioned Diagonal Plough with Polyurethane Blade and Shield	2000-2400	CBD-ST-XXL-P	64775	CBD-ST-XXL-P-S/S	64626
	900-1050	CBD-ST-M-PSS	64776	CBD-ST-M-PS-S/S	64780
	1200-1500	CBD-ST-L-PS	64777	CBD-ST-L-PS-S/S	64781
	1600-1800	CBD-ST-XL-PS	64778	CBD-ST-XL-PS-S/S	64782
	2000-2400	CBD-ST-XXL-PS	64779	CBD-ST-XXL-PS-S/S	64783

Lead time: 3 weeks

Replacement Parts

REF	DESCRIPTION	BELT WIDTH mm	BLADE WIDTH mm	MILD STEEL		STAINLESS STEEL	
				ORDERING NUMBER	ITEM CODE	ORDERING NUMBER	ITEM CODE
1	Diagonal Plough Main Frame	900-1050	N/A	CBD-ST-M-MF	61105	CBD-ST-M-MF-S/S	61108
		1200-1500	N/A	CBD-ST-L-MF	61106	CBD-ST-L-MF-S/S	61109
		1600-1800	N/A	CBD-ST-XL-MF	61107	CBD-ST-XL-MF-S/S	61110
		2000-2400	N/A	CBD-ST-XXL-MF	63749	CBD-ST-XXL-MF-S/S	63750
2	Standard Blade	900-1050	1750	CBD-ST-B	61111	CBD-ST-B	61111
		1200-1500	2250	CBD-ST-L-B	A2218	CBD-ST-L-B	A2218
		1600-1800	2750	CBD-ST-XL-B	A1784	CBD-ST-XL-B	A1784
		2000-2400	3250	CBD-ST-XXL-B	63752	CBD-ST-XXL-B	63752
	Polyurethane Blade	900-1050	1750	CBD-ST-B-P	64620	CBD-ST-B-P	64620
		1200-1500	2250	CBD-ST-L-B-P	64621	CBD-ST-L-B-P	64621
		1600-1800	2750	CBD-ST-XL-B-P	64482	CBD-ST-XL-B-P	64482
		2000-2400	3250	CBD-ST-XXL-B-P	64622	CBD-ST-XXL-B-P	64622
3	Stainless Steel Face Plate	900-1050	N/A	CBD-ST-M-FP	61112	CBD-ST-M-FP	61112
		1200-1500	N/A	CBD-ST-L-FP	61113	CBD-ST-L-FP	61113
		1600-1800	N/A	CBD-ST-XL-FP	61114	CBD-ST-XL-FP	61114
		2000-2400	N/A	CBD-ST-XXL-FP	63751	CBD-ST-XXL-FP	63751
-	Diagonal Plough Shields	900-1050	N/A	CBD-ST-M-S	64784	CBD-ST-M-S	64784
		1200-1500	N/A	CBD-ST-L-S	64785	CBD-ST-L-S	64785
		1600-1800	N/A	CBD-ST-XL-S	63024	CBD-ST-XL-S	63024
		2000-2400	N/A	CBD-ST-XXL-S	63791	CBD-ST-XXL-S	63791
4	Adjusting Arm	N/A		CBD-ST-AA	61096	CBD-ST-AA-S/S	61097
5	Mounting Channel	N/A		CBD-ST-MC	B0092	CBD-ST-MC	A2630
6	Threaded Bar	N/A		CBD-ST-TB-S/S	A2629	CBD-ST-TB-S/S	A2629
7	Compression Spring	N/A		CBD-ST-CS-S/S	A2215	CBD-ST-CS-S/S	A2215
8	Poly Bush	N/A		CBD-ST-PB	A2449	CBD-ST-PB	A2449
	Bush with Brass Insert			CBD-ST-BB	64310	CBD-ST-BB	64310
9	M12 NYLOC, S/S 316 nut & flat washer	N/A		N/A	N/A	N/A	N/A
10	Fasteners kit (M24 half nuts & flat washers - SS304) Qty: 4 each	N/A		CBD-ST-HN-S/S	61100	CBD-ST-HN-S/S	61100
11	M12 X40 Hex bolt & nuts (SS316) Qty: 8 each	N/A		N/A	N/A	N/A	N/A

Lead time: 3 weeks

Product Ordering Information

Belt Positioner™

Belt Positioners with CoreTech™ Rollers

SIZE	BELT WIDTH (MIN-MAX) mm	POSITIONER WIDTH (MIN-MAX) mm	ORDERING NUMBER	ITEM CODE	WT. KG.
Small	450-600	600-850	PSR-S	74558	29.2
Medium	750-1200	850-1400	PSR-M	74559	34.5
Large	1350-1800	1400-2075	PSR-L	74560	44.3
Extra Large	1800-2400	1800-3000	PSR-XL	74561	82.1

Note:

- Use next larger size for belt widths between ranges.
- Idler rollers on sizes:
 - S-M-L are 127 mm diameter
 - X are 152 mm diameter
- Finish: All steel parts are powder coated. All nuts and set screws are metric in 300 series Stainless Steel.
- This product is also available in Stainless Steel. Please contact Flexco® for pricing.



Belt Positioners with Steel Rollers

SIZE	BELT WIDTH (MIN-MAX) mm	POSITIONER WIDTH (MIN-MAX) mm	ORDERING NUMBER	ITEM CODE	WT. KG.
Small	450-600	600-850	PSR-S-F	62350	31.7
Medium	750-1200	850-1400	PSR-M-F	62351	38.5
Large	1350-1800	1400-2075	PSR-L-F	62352	49.8
Extra Large	1800-2400	1800-3000	PSR-XL-F	62353	90.7

Product Notes:

- The Positioner should be centered between two standard return rollers. For general applications-standard belts up to 1800 mm: position the unit no closer than 900 mm to a return roller and no farther than 1.8 meters.
- Works on the return side of the conveyor using simple angled rollers mounted in a fixed position to quickly and continuously funnel the belt into the correct path.
- A "quick fix" solution for belts that consistently wander to one side.
- Typically installed before the tail pulley to keep the belt centred at the critical loading point. Centre loading is the key to solving many top side tracking problems.
- Idler rollers make smooth contact with the return belt's bottom cover, eliminating excessive wear and damage to the belt's edges.
- Has no pivoting mechanism to freeze up and cause the unit to stop working.
- Once installed, no further adjustment is required.

Stock items (non-shaded) refer to (*) for specific lead time, if not specified, standard lead time applies.

Non-stock items (shaded) please contact Flexco for dispatch options and lead times.

Replacement Parts List

Belt Positioner™

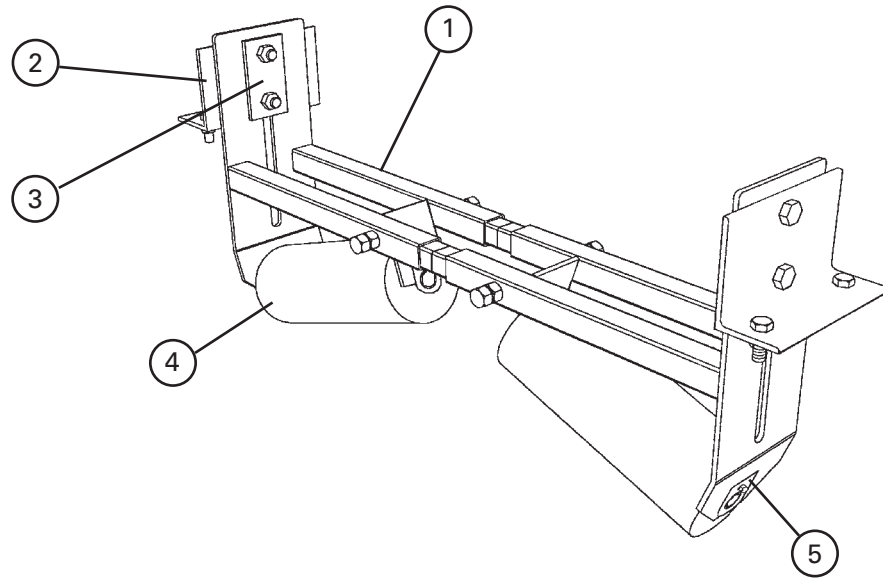

Replacement Parts

REF	DESCRIPTION	BELT WIDTH (MIN-MAX) mm	ORDERING NUMBER	ITEM CODE	WT. KG.
1	Small Frame Kit* (1 ea.)	450-650	RBPFK-S	73946	5.7
	Medium Frame Kit* (1 ea.)	750-1200	RBPFK-M	73947	6.5
	Large Frame Kit* (1ea.)	1350-1600	RBPFK-L	73948	8.8
	Extra Large Frame Kit* (1 ea.)	1800-2400	RBPFK-XL	73949	13.0
2	Mounting Bracket Kit* (1 ea.)		RBPMBK	74327	2.7
3	Clamp Plate	450-2400	RBPCP	73162	0.5

* Hardware included

Replacement Rollers

REF	DESCRIPTION	ORDERING NUMBER	ITEM CODE	WT. KG.
4	Small Steel Roller	RBPSR-S	74562	5.5
	Medium Steel Roller	RBPSR-M	74563	7.5
	Large Steel Roller	RBPSR-L	74564	10.5
	Extra Large Steel Roller	RBPSR-XL	74565	16.6
	Small CoreTech™ Roller	RBPSR-S-CCT	28250	3
	Medium CoreTech Roller	RBPSR-M-CCT	28251	3.5
	Large CoreTech Roller	RBPSR-L-CCT	28253	5
	Extra Large CoreTech Roller	RBPSR-XL-CCT	28254	8
5	Roller Retainer Kit*	RBPRET	A1622	0.2

Positioners come standard with Steel rollers.

Stock items (non-shaded) refer to (*) for specific lead time, if not specified, standard lead time applies.

Non-stock items (shaded) please contact Flexco for dispatch options and lead times.

Product Ordering Information

PTEZ™
Belt Trainer

PTEZ™ Belt Trainer

BELT WIDTH		ORDERING NUMBER	ITEM CODE	WT. KG.
mm	in.			
450	18	PTEZ-450	90265	54.4
600	24	PTEZ-600	90266	58.9
750	30	PTEZ-750	90267	63.5
900	36	PTEZ-900	90268	68
1050	42	PTEZ-1050	90269	72.6
1200	48	PTEZ-1200	90270	77.1

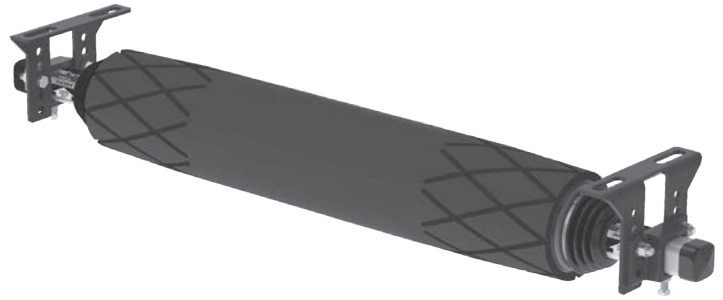

PTEZ BELT TRAINER

Product Notes:

- Simple adjustable mounting brackets ensure quick and accurate installation.
- Urethane roller cover ensures long-lasting performance.
- Works in multiple applications, yet economical. Single-direction and reversing belts. Wet or dry conditions. Belts with edge damage or wear. Belts mistracking to one or both sides.
- Easy ordering and installation. Enhanced to meet instant demands for training solutions, the PTEZ is available on a short lead time. The simple brackets and component construction also ensure a quick and easy installation.
- Uses tapered and patterned roller to activate the trainer movement. Pivot influences direction while Tilt increases the tension on the mistracked side—the result is two forces quickly moving the belt back to centre.
- Works with mechanically fastened or vulcanised belts.

Replacement Parts List

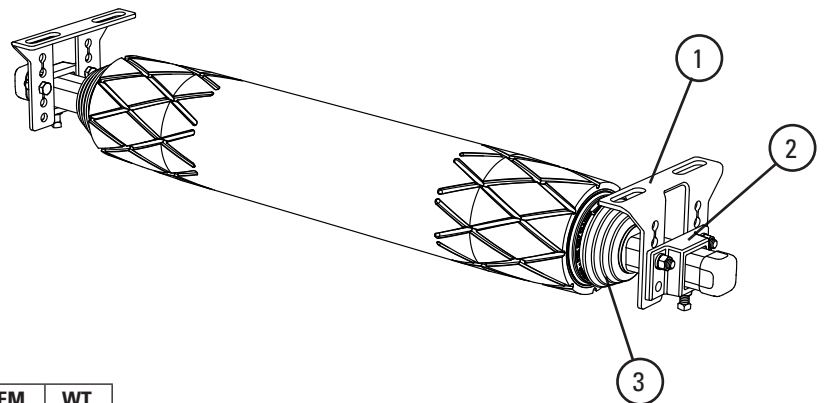

PTEZ™ Replacement Parts

REF	DESCRIPTION	ORDERING NUMBER	ITEM CODE	WT. KG.
1	PTEZ Mounting Bracket (2 ea.)	PTEZMB	90351	3.6
2	PTEZ Main Shaft Bracket (2 ea.)	PTEZPB	90352	2.7
3	PTEZ Main Shaft Dust Cover (2 ea.)	PTEZDC	90353	0.5

 Stock items (non-shaded) refer to (*) for specific lead time, if not specified, standard lead time applies.

 Non-stock items (shaded) please contact Flexco for dispatch options and lead times.

Specifications & Guidelines

PTEZ™
Belt Trainer

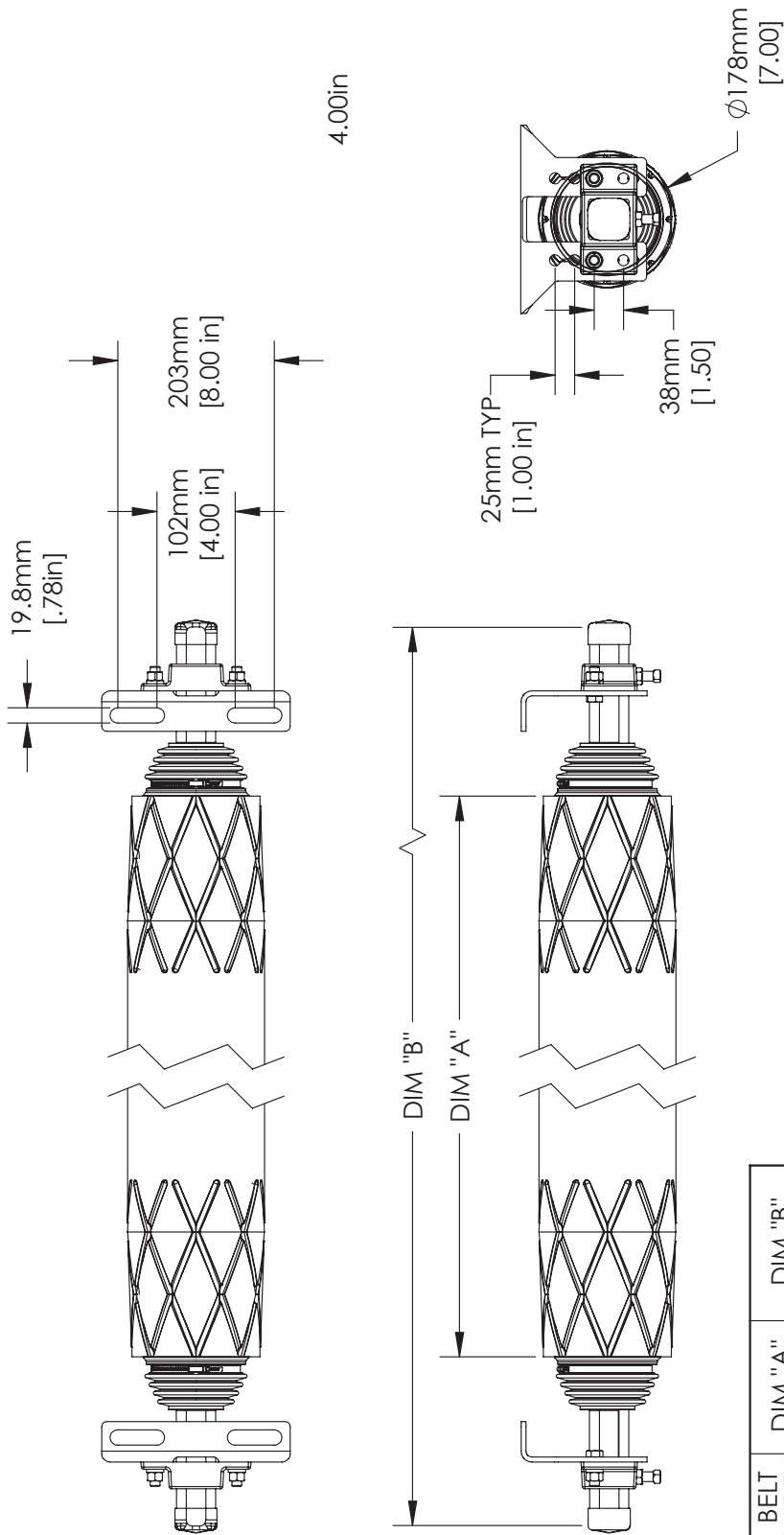

PART NUMBER	BELT WIDTH	DIM "A"	DIM "B"
90265	18"	476mm [18.75"]	914mm [36"]
90266	24"	629mm [24.75"]	1067mm [42"]
90267	30"	781mm [30.75"]	1219mm [48"]
90268	36"	933mm [36.75"]	1372mm [54"]
90269	42"	1086mm [42.75"]	1524mm [60"]
90270	48"	1238mm [48.75"]	1676mm [66"]

Product Ordering Information

PT Smart™
Belt Trainer

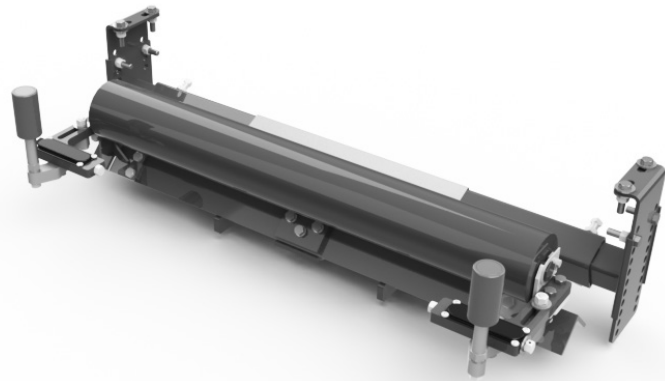

PT Smart Standard
Belt Trainer
(Roller Included)

PT Smart™ Belt Trainer

BELT TRAINER COMPLETE			REPLACEMENT ROLLERS	
BELT WIDTH MM	ORDERING NUMBER	ITEM CODE	ORDERING NUMBER	ITEM CODE
450	PTS-18R	77664	PTS-RR21	77680
600	PTS-24R	77665	PTS-RR27	77681
750	PTS-30R	77666	PTS-RR33	77682
900	PTS-36R	77667	PTS-RR39	77683
1050	PTS-42R	77668	PTS-RR45	77684
1200	PTS-48R	77669	PTS-RR51	77685
1350	PTS-54R	77670	PTS-RR57	77686
1500	PTS-60R	77671	PTS-RR63	77687
1800	PTS-72R	77672	PTS-RR75	77689

Lead time: 1 week

Selection Guidelines

CONVEYOR CRITERIA	PT SMART™
Top side mistracking	NO
Return side mistracking	YES
Belt mistracking to one side	EXCELLENT
Belt mistracking to both sides	EXCELLENT
Inconsistent tracking problem	EXCELLENT
Belt is cupped (heavy)	GOOD
Belt has low running tension	EXCELLENT
Belt has medium running tension	EXCELLENT
Belt has high running tension	GOOD
Approx. "upstream" effect*	6 M
Approx. "downstream" effect*	36 - 45 M

Specifications:

- Maximum Belt Speed5M/sec
- Temperature Rating-40°C to 71°C
- Belt DirectionOne way
- Available for Belt Widths450 to 1800 mm
- Application Range.....Medium-duty belts up to 1600 PIW max tension.
Belt width + 75 mm idler.
Belt thickness 25 mm maximum.

Stock items (non-shaded) refer to (*) for specific lead time, if not specified, standard lead time applies.

Non-stock items (shaded) please contact Flexco for dispatch options and lead times.

Replacement Parts List

PT Smart™
Belt Trainer

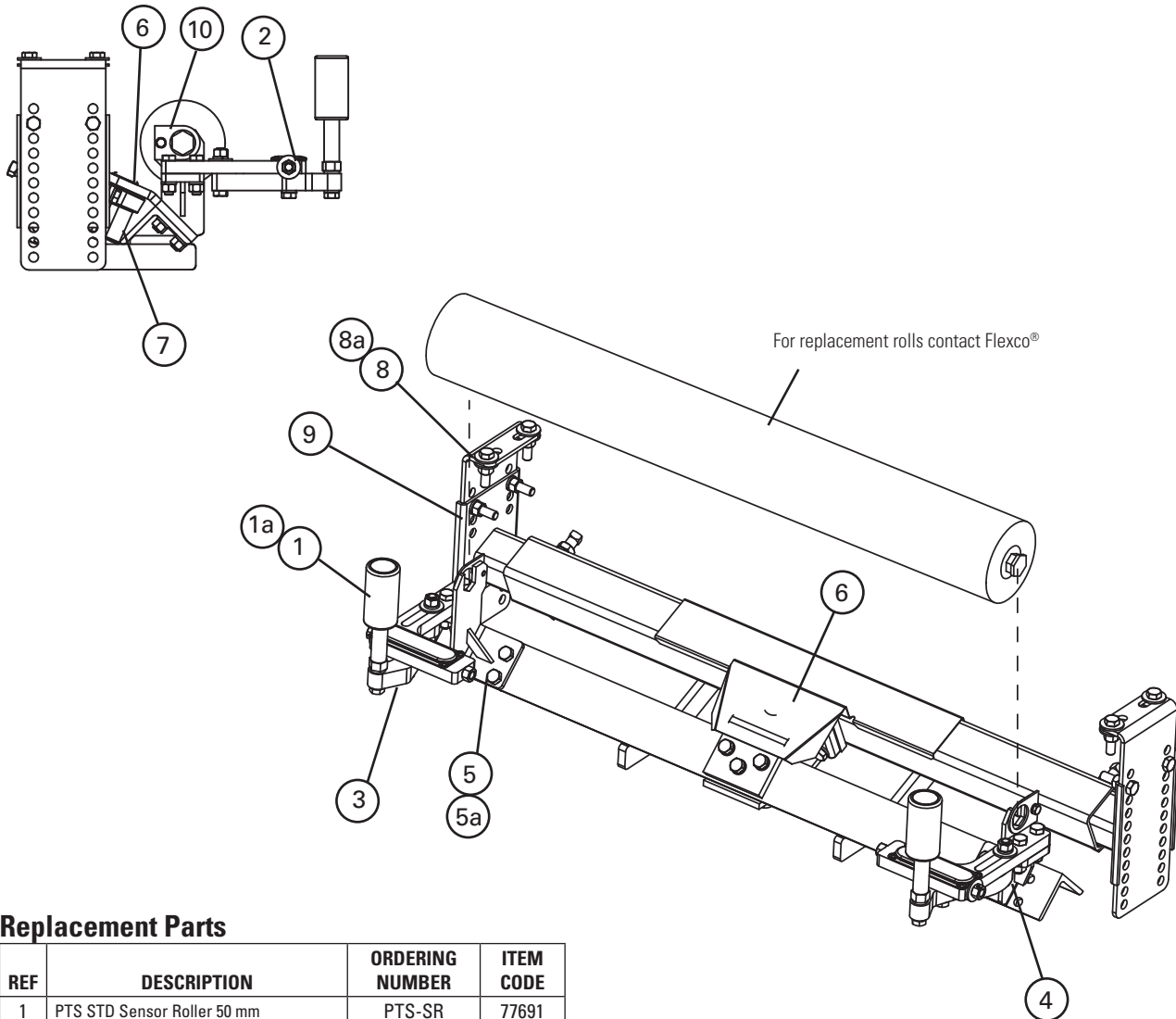

Replacement Parts

REF	DESCRIPTION	ORDERING NUMBER	ITEM CODE
1	PTS STD Sensor Roller 50 mm	PTS-SR	77691
1a	PTS HD® Sensor Roller 75 mm	PTS-HDSR	77692
2	PTS Adjusting Bolt Kit	PTS-ABK	77693
3	PTS Sensor Arm Kit (incl. 1 ea.)	PTS-SAK	77694
4	PTS RH Sensor Adjuster Assy	PTS-RHSAA	77755
	PTS LH Sensor Adjuster Assy	PTS-LHSAA	77756
5	PTS Idler Bracket Kit (incl. L & R)	PTS-IBK	77696
5a	PTS HD Idler Bracket Kit (incl. L & R)	PTS-HIBK	77697
6	PTS Pivot Shield	PTS-PS	77698
7	PTS Pivot Assy (Axle and housing)	PTS-PA	77699
8	PTS Mounting Bracket Kit	PTS-MBK	77700
8a	PTS Mounting Bracket Kit U/G	PTS-MBKUG	77701
9	PTS Extending Bracket Kit (incl. L & R)	PTS-EBK	77702
10	Roller Retainer Kit	RBPRET	73163

*Hardware included

Stock items (non-shaded) refer to (*) for specific lead time, if not specified, standard lead time applies.

Non-stock items (shaded) please contact Flexco for dispatch options and lead times.

Specifications & Guidelines

PT Smart™
Belt Trainer

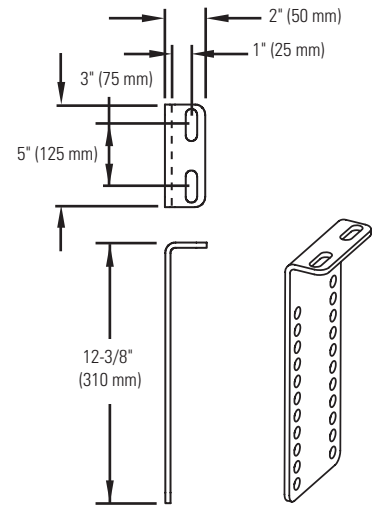
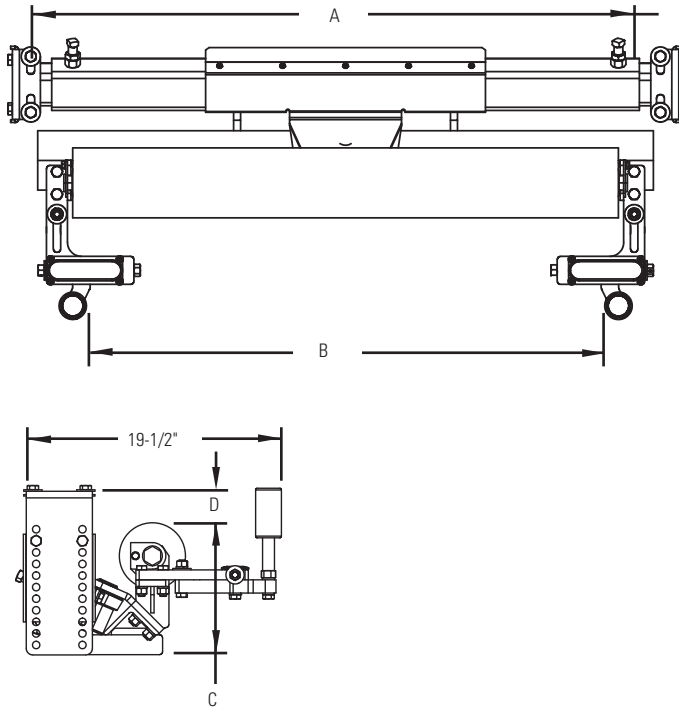

PT Smart™ Standard

BELT WIDTH mm	ITEM CODE	A	B	C	D (VERTICAL ADJUSTMENT)
450	77664	575-875mm	250-575 mm	250 mm	0-250 mm
600	77665	725-1025mm	400-725 mm		
750	77666	875-1175mm	550-875 mm		
900	77667	1025-1325mm	700-1025 mm		
1050	77668	1175-1475mm	825-1175 mm		
1200	77669	1325-1625mm	1000-1325 mm		
1350	77670	1475-1775mm	1150-1475 mm		
1500	77671	1625-1925mm	1300-1625 mm		
1800	77672	1925-2225mm	1600-1925 mm		

Product Ordering Information

PT Pro Belt Trainer



PT Pro Belt Trainer

Version	Belt Trainer Complete				
	Belt Width		Ordering Number	Item Code	Wt. Kg.
	mm	in.			
Standard	450	18	PTP18R	79267	119.8
	600	24	PTP24R	79268	129.5
	750	30	PTP30R	79269	136.8
	900	36	PTP36R	79270	150.1
	1050	42	PTP42R	79271	158.1
	1200	48	PTP48R	79272	166.1
	1350	54	PTP54R	79273	174.1
	1500	60	PTP60R	79274	182.1
Heavy-Duty	1800	72	PTP72R	79275	198.0
	1200	48	PTPHD48R	79276	215.9
	1350	54	PTPHD54R	79277	227.6
	1500	60	PTPHD60R	79278	239.4
	1800	72	PTPHD72R	79279	262.7
	2100	84	PTPHD84R	79280	301.5
Heavy-Duty	2400	96	PTPHD96R	79281	319.8
	Version	Replacement Rollers			
Belt Width		Ordering Number	Item Code	Wt. Kg.	
mm					in.
Standard	450	18	NS6DV-18-9.625-A45	26714	7.73
	600	24	NS6DV-24-12.625-A45	26715	8.64
	750	30	NS6DV-30-15.625-A45	26716	9.55
	900	36	NS6DV-36-18.625-A45	26717	13.45
	1050	42	NS6DV-42-21.625-A45	26718	14.64
	1200	48	NS6DV-48-24.625-A45	26719	15.91
	1350	54	NS6DV-54-27.625-A45	26720	17.14
	1500	60	NS6DV-60-30.625-A45	26721	18.36
Heavy-Duty	1800	72	NS6DV-72-36.625-A45	26722	20.77
	1200	48	NS7DV-48-24.625-A105	26723	21.05
	1350	54	NS7DV-54-27.625-A105	26724	22.59
	1500	60	NS7DV-60-30.625-A105	26725	24.09
	1800	72	NS7DV-72-36.625-A105	26726	27.14
	2100	84	NS7DV-84-42.625-A105	26727	35.00
2400	96	NS7DV-96-48.625-A105	26728	39.00	

Stock items (non-shaded) refer to (*) for specific lead time, if not specified, standard lead time applies.

Non-stock items (shaded) please contact Flexco for dispatch options and lead times.

Specifications & Guidelines

PT Pro Belt Trainer

Specifications

Maximum Belt Speed	Standard Duty - 5M/sec (1000 fpm) Heavy Duty - 7M/sec (1400 fpm)
Temperature Rating	-35° C to 82° C (-30° F to 180° F)
Belt Direction	One-Way or Reversing
Available for Belt Widths	450 - 2400mm (18" - 96")
Mounting Adjustability	Horizontal = belt width +229 - 381mm (9" to 15") Vertical = 305mm (12")

Selection Guidelines

Model	Application Range
PT Pro™	Medium-duty belts 150 PIW min to 1600 PIW max tension. Belt width 450 - 1800mm (18" - 72")
PT Pro HD	Heavy-duty belts 300 PIW min to 2400 PIW max tension. Belt width 1200 - 2400mm (48" - 96")

*Typical results; actual results may vary

Conveyor Criteria

Top side mistracking	NO
Return side mistracking	YES
Reversing	YES
Belt mistracking to one side	EXCELLENT
Belt mistracking to both sides	EXCELLENT
Inconsistent tracking problem	EXCELLENT
Belt is cupped (heavy)	GOOD
Belt has low running tension (150 - 300 PIW)	GOOD
Belt has medium running tension (300 - 600 PIW)	EXCELLENT
Belt has high running tension (600+ PIW)	GOOD
Approx. "upstream" effect*	6 M (20')
Approx. "downstream" effect*	30 M (100')

Replacement Parts List

PT Pro Belt Trainer

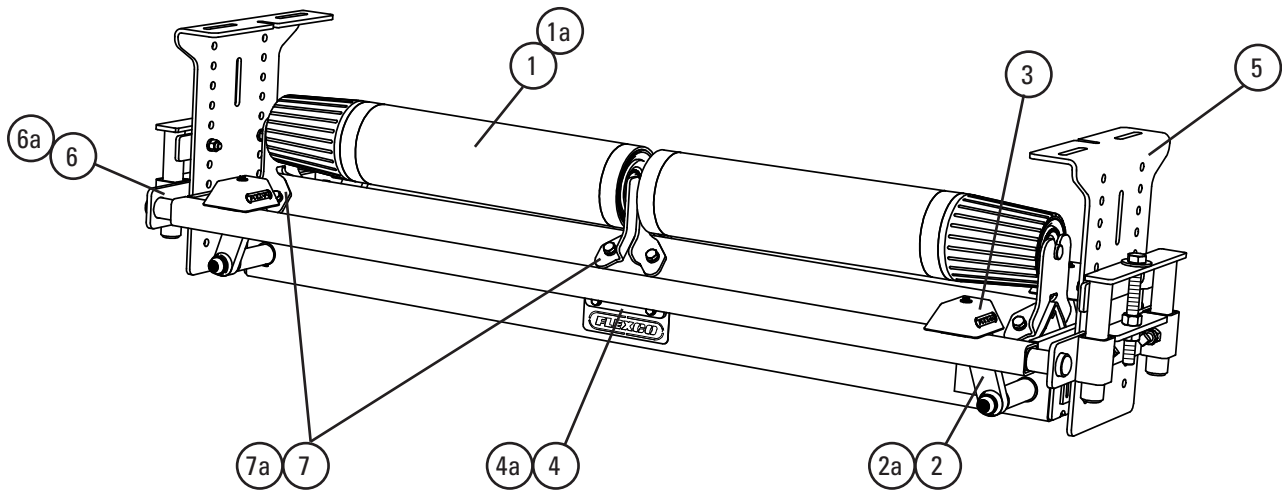

Replacement Idlers

Ref	Belt Width		Description	Ordering Number	Item Code	Wt. Kg.
	mm	in.				
1	450	18	PTPR Idler 18" (450mm)	NS6DV-18-9.625-A45	26714	7.7
	600	24	PTPR Idler 24" (600mm)	NS6DV-24-12.625-A45	26715	8.6
	750	30	PTPR Idler 30" (750mm)	NS6DV-30-15.625-A45	26716	9.5
	900	36	PTPR Idler 36" (900mm)	NS6DV-36-18.625-A45	26717	13.5
	1050	42	PTPR Idler 42" (1050mm)	NS6DV-42-21.625-A45	26718	14.6
	1200	48	PTPR Idler 48" (1200mm)	NS6DV-48-24.625-A45	26719	15.9
	1350	54	PTPR Idler 54" (1350mm)	NS6DV-54-27.625-A45	26720	17.1
	1500	60	PTPR Idler 60" (1500mm)	NS6DV-60-30.625-A45	26721	18.4
1a	1800	72	PTPR Idler 72" (1800mm)	NS6DV-72-36.625-A45	26722	20.8
	1200	48	PTPR HD Idler 48" (1200mm)	NS7EV-48-24.625-A105	26723	21.0
	1350	54	PTPR HD Idler 54" (1350mm)	NS7EV-54-27.625-A105	26724	22.6
	1500	60	PTPR HD Idler 60" (1500mm)	NS7EV-60-30.625-A105	26725	24.1
	1800	72	PTPR HD Idler 72" (1800mm)	NS7EV-72-36.625-A105	26726	27.1
	2100	84	PTPR HD Idler 84" (2100mm)	NS7EV-84-42.625-A105	26727	35.0
2400	96	PTPR HD Idler 96" (2400mm)	NS7EV-96-48.625-A105	26728	39.0	
2		PT Pro Link Bar*	PTPLB	79470	5.3	
2a		PT Pro HD Link Bar*	PTPLB-HD	79473	6.5	
3		PT Pro Link Shield	PTP-LS	79488	0.1	
4		PT Pro Pivot Assy	PTP-RPA	79476	5.9	
4a		PT Pro HD Pivot Assy	PTP-HDRPA	79478	6.5	
5		PT Pro Mounting Bracket	PTP-RMB	79490	10.2	
6		PT Pro Extension Bracket Kit	PTP-EBKR	79484	13.5	
6a		PT Pro HD Extension Bracket Kit	PTP-HDEBKR	79486	16.4	
7		PT Pro Roller Bracket Kit**	PTP-RRB	79491	2.7	
7a		PT Pro HD Roller Bracket Kit**	PTP-HDRBK	79492	3.3	

*Set of 4

**Bracket set for 1 roller

Stock items (non-shaded) refer to (*) for specific lead time, if not specified, standard lead time applies.

Non-stock items (shaded) please contact Flexco for dispatch options and lead times.

Product Ordering Information

PT Max™ Belt Trainer - Mild Steel

PT Max™ Top Side

BELT WIDTH mm	ORDERING NUMBER	WT. KG.
750	PTM-750-3	130.0
900	PTM-900-3	140.0
1050	PTM-1050-3	147.0
1200	PTM-1200-3	155.0
1350	PTM-1350-3	161.0
1500	PTM-1500-3	164.0
1600	PTM-1600-3	168.0
1800	PTM-1800-3	186.0
2000	PTM-2000-3	204.0
2400	PTM-2400-3	240.0
2600	PTM-2600-3	258.0
3000	PTM-3000-3	294.0

Finish: Steel parts are sandblasted, primed, and powder coated



PT MAX TOP SIDE BELT TRAINER:
The PT MAX is delivered without rollers, but is manufactured to accommodate on site rollers.
Includes Servo Rollers.

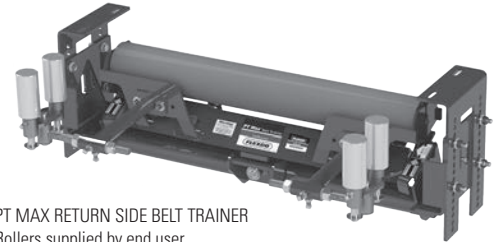

PT MAX RETURN SIDE BELT TRAINER
Rollers supplied by end user.

PT Max™ Return Side

BELT WIDTH mm	ORDERING NUMBER	WT. KG.
750	PTM-750-1	130.0
900	PTM-900-1	140.0
1050	PTM-1050-1	147.0
1200	PTM-1200-1	155.0
1350	PTM-1350-1	161.0
1500	PTM-1500-1	164.0
1600	PTM-1600-1	168.0
1800	PTM-1800-1	186.0
2000	PTM-2000-1	204.0
2400	PTM-2400-1	240.0
2600	PTM-2600-1	258.0
3000	PTM-3000-1	294.0

Finish: Steel parts are sandblasted, primed, and powder coated

PT Max™ V-Return

BELT WIDTH mm	ORDERING NUMBER	WT. KG.
750	PTM-750-2	130.0
900	PTM-900-2	140.0
1050	PTM-1050-2	147.0
1200	PTM-1200-2	155.0
1350	PTM-1350-2	161.0
1500	PTM-1500-2	164.0
1600	PTM-1600-2	168.0
1800	PTM-1800-2	186.0
2000	PTM-2000-2	204.0
2400	PTM-2400-2	240.0
2600	PTM-2600-2	258.0
3000	PTM-3000-2	294.0

Finish: Steel parts are sandblasted, primed, and powder coated

Replacement Servo Rollers

DESCRIPTION	ORDERING NUMBER	ITEM CODE	WT. KG.
SERVO 149x102	PTMSR	A0235	2.0
PTM Sensor Roller 75mmx102	MSR	74914	3.0



PT MAX V-RETURN BELT TRAINER

Product Notes:

- Please note PT Max™ no longer utilises generic item codes. Each PT Max is specifically engineered and is allocated a unique 6 digit item code upon manufacture which is also the serial number.
- FPT Max™ is custom manufactured to suit your requirements. Manufacture cannot commence without a data sheet; contact Flexco® for specification order sheet.
- For larger sizes please contact Flexco (Aust) Pty Ltd.
- Please note that PT Max™ freight terms are ex-works Bundaberg.
- Also available in other roller configurations—please contact Flexco.
- PT Max™ lead time is 4 weeks ex-Bundaberg from the receipt of an order and all data requirements.

U.S. Patent No. 5,358,098

Product Ordering Information

PT Max™ Belt Trainer - Stainless Steel

PT Max™ Top Side

BELT WIDTH mm	ORDERING NUMBER	WT. KG.
750	PTM-750-3-S/S	130.0
900	PTM-900-3-S/S	140.0
1050	PTM-1050-3-S/S	147.0
1200	PTM-1200-3-S/S	155.0
1350	PTM-1350-3-S/S	161.0
1600	PTM-1600-3-S/S	168.0
1800	PTM-1800-3-S/S	186.0
2000	PTM-2000-3-S/S	204.0
2400	PTM-2400-3-S/S	240.0
2600	PTM-2600-3-S/S	258.0
3000	PTM-3000-3-S/S	294.0

Finish: Steel parts are sandblasted, primed, and powder coated

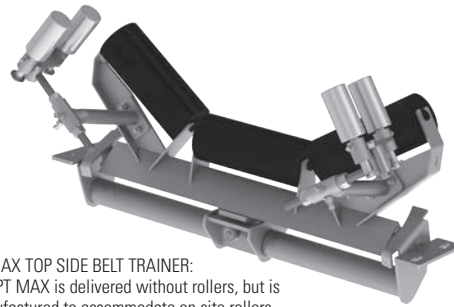

PT MAX TOP SIDE BELT TRAINER:
The PT MAX is delivered without rollers, but is manufactured to accommodate on site rollers.
Includes Servo Rollers.

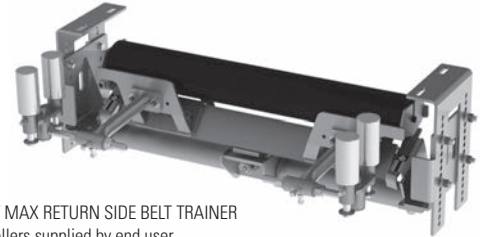

PT MAX RETURN SIDE BELT TRAINER
Rollers supplied by end user.

PT Max™ Return Side

BELT WIDTH mm	ORDERING NUMBER	WT. KG.
750	PTM-750-1-S/S	130.0
900	PTM-900-1-S/S	140.0
1050	PTM-1050-1-S/S	147.0
1200	PTM-1200-1-S/S	155.0
1350	PTM-1350-1-S/S	161.0
1600	PTM-1600-1-S/S	168.0
1800	PTM-1800-1-S/S	186.0
2000	PTM-2000-1-S/S	204.0
2400	PTM-2400-1-S/S	240.0
2600	PTM-2600-1-S/S	258.0
3000	PTM-3000-1-S/S	294.0

Finish: Steel parts are sandblasted, primed, and powder coated

PT Max™ V-Return

BELT WIDTH mm	ORDERING NUMBER	WT. KG.
750	PTM-750-2-S/S	130.0
900	PTM-900-2-S/S	140.0
1050	PTM-1050-2-S/S	147.0
1200	PTM-1200-2-S/S	155.0
1350	PTM-1350-2-S/S	161.0
1600	PTM-1600-2-S/S	168.0
1800	PTM-1800-2-S/S	186.0
2000	PTM-2000-2-S/S	204.0
2400	PTM-2400-2-S/S	240.0
2600	PTM-2600-2-S/S	258.0
3000	PTM-3000-2-S/S	294.0

Finish: Steel parts are sandblasted, primed, and powder coated

Replacement Servo Rollers

DESCRIPTION	ORDERING NUMBER	ITEM CODE	WT. KG.	NZD
PTM Sensor Roller 75mmx102	MSR-S/S	C7673	3.0	\$ 744.00

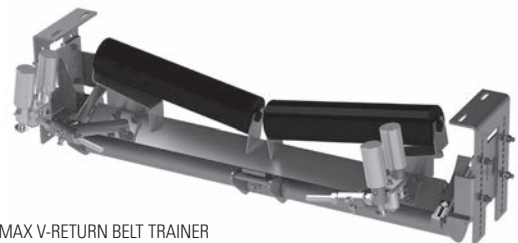

PT MAX V-RETURN BELT TRAINER

Product Notes:

- Please note PT Max™ no longer utilises generic item codes. Each PT Max is specifically engineered and is allocated a unique 6 digit item code upon manufacture which is also the serial number.
- PT Max™ is custom manufactured to suit your requirements. Manufacture cannot commence without a data sheet; contact Flexco® for specification order sheet.
- Stainless Steel PT Max™ is made from 304 Stainless Steel as standard, please specify specific requirements in the data sheet.
- For larger sizes please contact Flexco (Aust) Pty Ltd.
- Please note that PT Max™ freight terms are ex-works Bundaberg.
- Also available in other roller configurations—please contact Flexco.
- PT Max™ lead time is 4 weeks ex-Bundaberg from the receipt of an order and all data requirements.

Replacement Parts List

PT Max™
Belt Trainer

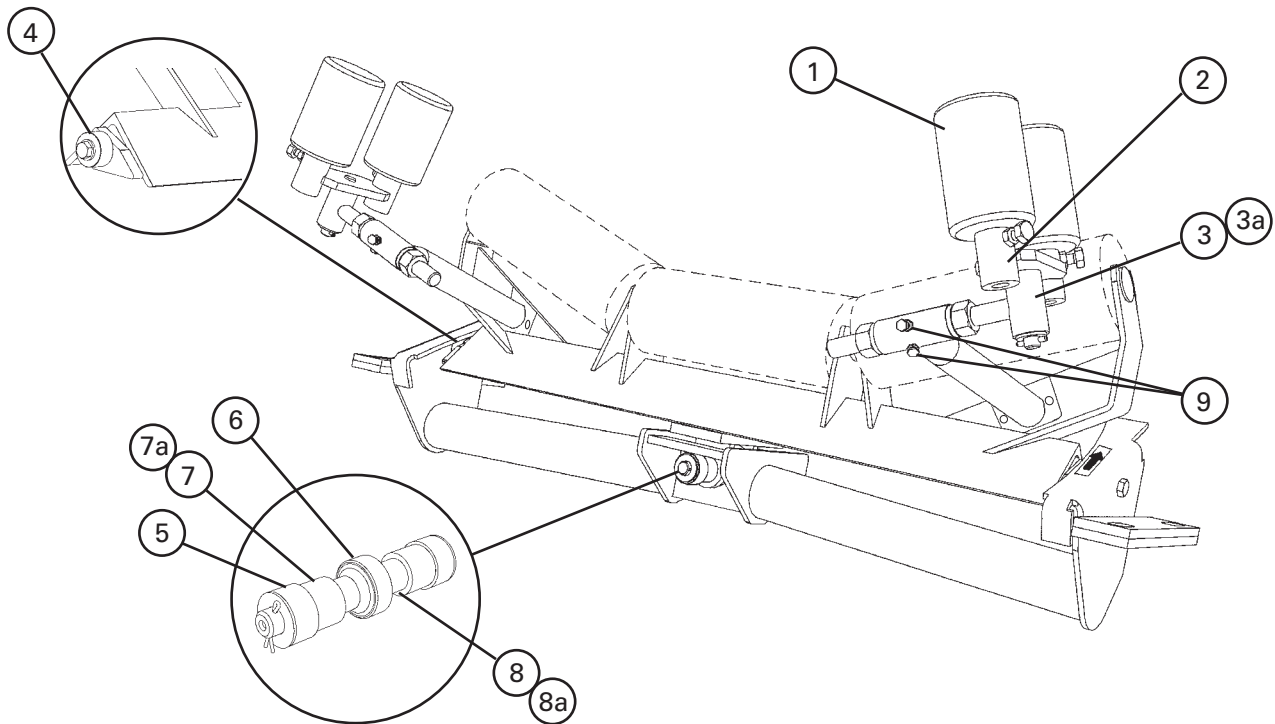

Replacement Parts

REF	DESCRIPTION	BELT WIDTH (mm)	MILD STEEL		STAINLESS STEEL	
			ORDERING NUMBER	ITEM CODE	ORDERING NUMBER	ITEM CODE
1	Sensor Roller* (3" solid roller) (1 ea.)	750-2100	MSR	74914	MSR-S/S	64924
2	Swivel Mount Kit*	750-2100	PMSMK	74916	PMSMK-S/S	64925
3	Adjusting Arm Kit*	750-1500	MAK	74918	MAK-S/S	64926
3a	HD Adjusting Arm Kit*	1350-2100	MAKHD	74919	MAKHD	74919
4	Outer Roller Kit* (incl. 2 rollers, roller thimbles and bolts, nuts and washers)	750-2100	MORK	74921	MORK	74921
5	Center Roller Kit* (incl. 2 rollers, 2 washers, and 2 cotter pins)	750-2100	MCRK	74923	MCRK	74923
6	Center Bearing*	750-2100	MCB	74925	MCB	74925
7	Center Shaft Spacer Kit (incl. 2 spacers)	750-1500	MCSK	74927	MCSK	74927
7a	HD Center Shaft Spacer Kit (incl. 2 spacers)	1350-2100	MCSKHD	74928	MCSKHD	74928
8	Center Shaft	750-1500	MCS	74930	MCS	74930
8a	HD Center Shaft	1350-2100	MCSHD	74931	MCSHD	74931
9	Frame Arm Set Screw Kit (incl. 2 setscrews and 2 jam nuts)	750-3000	MFASK	75531	MFASK	75531
-	Center Bearing Kit (incl. 1 ea. items 5, 6, 7, 8)	750-1500	MCBK	76025	MCBK	76025
-	HD Center Bearing Kit (incl. 1 ea. items 5, 6, 7a, 8a)	1350-2100	MCBKHD	76026	MCBKHD	76026

Lead time: 3 weeks

Stock items (non-shaded) refer to (*) for specific lead time, if not specified, standard lead time applies.

Non-stock items (shaded) please contact Flexco for dispatch options and lead times.

Product Ordering Information

RMC1 Skirt Clamps

Flex-Lok™ Skirt Clamp-Mild Steel

- One Standard Skirt Clamp includes one 2 M mounting channel, 4 clamp plates, 4 clamp pins and one 2 M restraining bar.
- One Mini Skirt Clamp includes one 2 M mounting channel, 3 clamp plates, 3 clamp pins and one 2 M restraining bar.
- Skirt board and rubber not included.

DESCRIPTION	ORDERING NUMBER	ITEM CODE	WT. KG.
Flex-Lok™ Skirt Clamp Complete	FLSC2000	71053	18.0
Mini Flex-Lok™ Skirt Clamp Complete	FLSCM2000	71148	15.0
REPLACEMENT PARTS			
Toggle Pin	FLSC-TP	71056	1.0
Clamp Plate	FLSC-CP	71057	1.0
Mini Clamp Plate	FLSCM-CP	71140	1.0
Clamp Bar-2000 mm	FLSC2000-CB	71061	5.0
Mounting Channel-2000 mm	FLSC2000-MC	71059	3.0

Finish: Clamp plates and clamp bars are powder coated steel. Mounting channel is powder coated. Toggle pins are zinc passivated steel. Skirt rubber is not included.

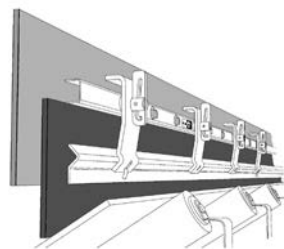

Standard

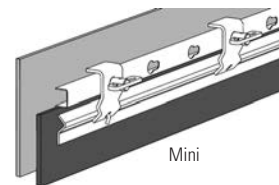

Mini

Flex-Lok™ Skirt Clamp-Stainless Steel

- One Standard Skirt Clamp includes one 2 M mounting channel, 4 clamp plates, 4 clamp pins and one 2 M restraining bar.
- One Mini Skirt Clamp includes one 2 M mounting channel, 3 clamp plates, 3 clamp pins and one 2 M restraining bar.
- Skirt board and rubber not included.

DESCRIPTION	ORDERING NUMBER	ITEM CODE	WT. KG.
Flex-Lok™ Skirt Clamp Complete	FLSC2000-S/S	A1436	20.0
Mini Flex-Lok™ Skirt Clamp Complete	FLSCM2000-S/S	61471	15.0
REPLACEMENT PARTS			
Toggle Pin	FLSC-TP-S/S	A1437	1.0
Clamp Plate	FLSC-CP-S/S	A1438	1.0
Mini Clamp Plate	FLSCM-CP-S/S	a2596	1.0
Clamp Bar-2000 mm	FLSC2000-CB-S/S	A1439	5.0
Mounting Channel-2000 mm	FLSC2000-MC-S/S	A1440	3.0

All components supplied in 300 Series Stainless.

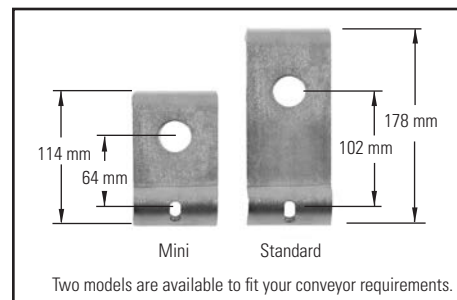

Flex-Lok™ Specifications

SKIRT RUBBER THICKNESS RANGE	
Thickness Range	8-25 mm

Product Notes:

- Solves material spillage problems in the conveyor loading zone.
- Stops material loss, eliminates safety hazards, and reduces wear on conveyor components.

Stock items (non-shaded) refer to (*) for specific lead time, if not specified, standard lead time applies.

Non-stock items (shaded) please contact Flexco for dispatch options and lead times.

Product Ordering Information

RMC1 Skirt Clamps

Flex-Seal™ Skirt System

DESCRIPTION	ORDERING NUMBER	ITEM CODE	WT. KG.
Flex-Seal™ Skirt System*	RMC-FS	76558	13.4
REPLACEMENT PARTS**			
Angle Plate	RMC2-AP	76559	8.6
Angle Plate Stainless Steel	RMC2-AP-S/S	A2704	8.6
PAL PAK	RMC1-PP	75832	3.0
Bolt-On PAL PAK	RMC1-BPP	76415	3.0
Clamp Bar	RMC1-CB	75817	1.8

*Flex-Seal Skirt System includes angle plate, one Bolt-On PAL PAK, and one 1.2 M clamp bar. Skirt board and rubber not included. Skirt rubber thickness range: 8 mm to 19 mm

**Replacement parts include two Bolt-On clamp pins and two clamp plates.

Flex-Seal™ Specifications

SKIRT RUBBER THICKNESS RANGE	
Width Required	150 mm
Thickness Range	8-19 mm



Bolt-On PAL PAK

Product Ordering Information

Standard Urethane Skirting

Standard Urethane Skirting

Height		Thickness		Length		CHAMFER	ORDERING NUMBER	ITEM CODE	WT. KG.
mm	in	mm	in	m	ft				
150	6	12	1/2	7.6	25	35°	SKPU-6x1/2x25	90283	18.1
150	6	20	3/4				SKPU-6x3/4x25	90284	27.3
200	8	12	1/2				SKPU-6x1/2x25	90285	26.4
200	8	20	3/4				SKPU-6x3/4x25	90286	40.0

Stock items (non-shaded) lead time 1 working day.

Non-stock items (shaded) please refer to Flexco for dispatch options and lead times.



Product Notes:

- Urethane skirting offers a more wear-resistant material than typical rubber, often providing as much as 3-4 times the wear life in similar applications. The lower coefficient of friction reduces strain on the system.
- Works with Flexco series of skirt clamps that offer simple serviceability: RMC1/PAL-Pak, Flex-Lok, and Flex-Seal.
- Uses soft durometer (65A) urethane with exceptional tear resistance to ensure a good seal and long belt life.
- 7.6M (25') roll size ensures easy transportation, while the 35° chamfer eliminates the typical skirting break-in period.
- Suitable for most applications: single direction or reversing belts, wet or dry conditions, old or new belts, vulcanised or mechanically-spliced systems.
- Rated for temperatures from -30°C to 82°C (-20°F to 180°F)

Product Ordering Information

Flexco® Belt Maintenance Tools Belt Lifters & Clamps

Flex-Lifter™ Conveyor Belt Lifter

Easy and safe way to lift tensioned belts so mechanical splicing or other maintenance work can be done.



DESCRIPTION	ORDERING NUMBER	ITEM CODE	WT. KG.
Medium Flex-Lifter 900 - 1500 mm	FL-M	76979	27.3
Large Flex-Lifter 1200 - 1800 mm	FL-L	76980	33.6
XL Flex-Lifter 1800 - 2400 mm	FL-XL	76983	68.5
OPTIONAL PARTS			
Extension Leg - Medium	FLEL-M	76472	1.4
Extension Leg - Large	FLEL-L	76473	1.7
Extension Leg - XL (includes 2 ext. legs)	FLELK-XL	76986	5.9
Extension Leg Pin (with lanyard)	FLELP	76474	0.1
Trough Wing - Medium (with brace)	FLTW-M	76476	0.6
Trough Wing - Large (with brace)	FLTW-L	76477	0.7
Trough Wing - XL (with brace)	FLTW-XL	76985	2.0
Retainer Pin Pack (includes 4 pins)	FLRP	76478	0.5
Retainer Clip Pack (includes 4 clips)	FLCP	76479	0.1
Return Lift Bar - Medium	FLRLB-M	76482	8.4
Return Lift Bar - Large	FLRLB-L	76481	18.2
V-Return Lift Bar - XL	FLVRL-XL	76984	28.6
Flex-Trolley	N/A	77729	N/A

Return lift bars included with medium and large models. Sold separately with XL models.

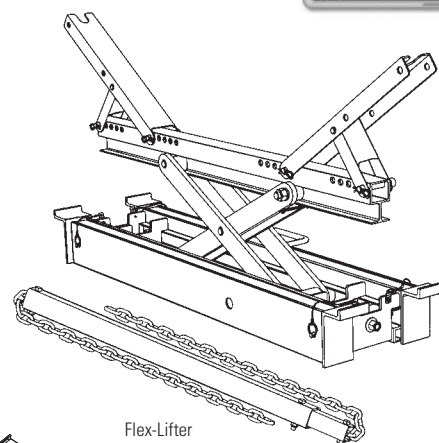

Flex-Lifter

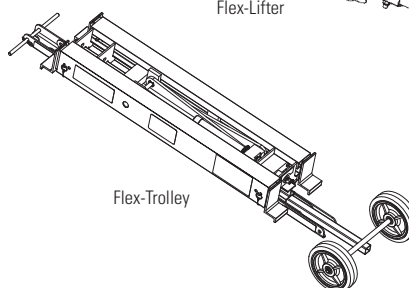

Flex-Trolley

Aluminum Content Flex-Lifter

ALUMINUM ALLOY TYPE	PERCENT	
	MG-MAGNESIUM	TI-TITANIUM
4043	0.05%	0.2%
5356	5.5%	0.2%
6005	0.6%	0.1%
6061	1.0%	0.0%
6063	0.7%	0.0%
7075	2.5%	0.0%

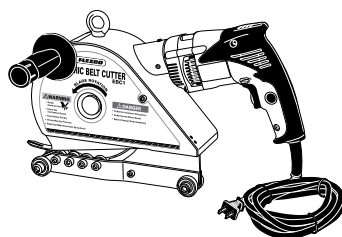

Electric Belt Cutter

Electric Belt Cutter

DESCRIPTION	ORDERING NUMBER	ITEM CODE	WT. KG.
Electric Cutter Complete - 25 mm	EBC-1	30001	9.0
Electric Cutter Complete - 50 mm	EBC-2	30002	10.0
Cordless Electric Cutter Complete - 25 mm	CEBC-1	30018	9.0
Cordless Electric Cutter Complete - 50 mm	CEBC-2	30019	10.0
REPLACEMENT PARTS			
Replacement blade for EBC-1	EBC-1-B	30003	1.0
Replacement blade for EBC-2	EBC-2-B	30004	1.0
Retrofit Rail Kit for EBC1/CEBC1/PBC1	EBC1-RK	30033	0.6
Retrofit Rail Kit for EBC2/CEBC2/PBC2	EBC2-RK	30034	0.8

Pneumatic Belt Cutter

DESCRIPTION	ORDERING NUMBER	ITEM CODE	WT. KG.
Pneumatic Cutter Complete - 25 mm	PBC-1	61356	12.5
Pneumatic Cutter Complete - 50 mm	PBC-2	61357	13.5
REPLACEMENT PARTS			
Filter Set	PBC-FR	61358	2.0

Cutting Capacity

BELT TYPE	EBC-1	EBC-2
Rubber	Up to 25 mm	Up to 50 mm
PVC	Up to 630 EP	Up to 2000 EP

Stock items (non-shaded) refer to (*) for specific lead time, if not specified, standard lead time applies.

Non-stock items (shaded) please contact Flexco for dispatch options and lead times.

INDEX By Ordering Number

Ordering Number	Item Code	Page #	Ordering Number	Item Code	Page #	Ordering Number	Item Code	Page #	Ordering Number	Item Code	Page #
CBD-L-S/S	A1856	145	AWTNCB	76069	32	C-PSTA	81045	107	CART-72/1800-S/S	78583	53
CBD-M-S/S	A1854	145	BP-LA	73127	140	CART-24/600-S/S	78576	47	CART-72/1800-S/S	78583	79
CBD-S-S/S	64178	145	BP-LA-S/S	A0614	140	CART-24/600-S/S	78576	53	CART-72/1800-S/S	78583	81
CBD-XL-S/S	76318	145	BP-MB	73123	140	CART-24/600-S/S	78576	79	CART-72/1800-S/S	78583	86
CBD-XXL	64787	145	BP-MB-S/S	A0615	140	CART-24/600-S/S	78576	81	CART-72/1800-S/S	78583	88
CBD-XXL-S/S	63554	145	BP-SC	73125	140	CART-24/600-S/S	78576	86	CART-72/1800-S/S	78583	93
HSHD-S/S	76467	42	BP-SC-S/S	A0616	140	CART-24/600-S/S	78576	88	CART-72/1800-S/S	78583	95
PTEZDC	90353	149	BP-TB	73138	140	CART-24/600-S/S	78576	93	CART-72/1800-S/S	78583	100
PTEZMB	90351	149	BP-TL	73141	140	CART-24/600-S/S	78576	95	CART-72/1800-S/S	78583	101
PTEZPB	90352	149	BP-TL-S/S	A0617	140	CART-24/600-S/S	78576	100	CART2-114/2850-S/S	78639	48
ABU	76788	107	BP-UB	73139	140	CART-24/600-S/S	78576	101	CART2-114/2850-S/S	78639	54
ABU	76788	107	BP1050	73110	140	CART-30/750-S/S	78577	79	CART2-120/3000-S/S	78588	48
ABU	76788	108	BP1050-B	73780	140	CART-30/750-S/S	78577	81	CART2-120/3000-S/S	78588	54
ABU	76788	108	BP1050-HD-B	A2237	140	CART-30/750-S/S	78577	86	CART2-120/3000-S/S	78588	79
ACME-N	62591	55	BP1050-S/S	76342	140	CART-30/750-S/S	78577	88	CART2-120/3000-S/S	78588	81
ACME-N	62591	55	BP1200	73112	140	CART-30/750-S/S	78577	93	CART2-120/3000-S/S	78588	86
ACME-N	62591	55	BP1200-1400-PL	73118	140	CART-30/750-S/S	78577	95	CART2-120/3000-S/S	78588	88
ACME-N	62591	55	BP1200-1400-PL-S/S	A0621	140	CART-30/750-S/S	78577	100	CART2-120/3000-S/S	78588	93
ACME-PRK	62496	55	BP1200-B	73781	140	CART-30/750-S/S	78577	101	CART2-120/3000-S/S	78588	95
ACME-PRK	62496	55	BP1200-HD-B	73301	140	CART-36/900-S/S	78578	47	CART2-120/3000-S/S	78588	100
ACME-PRK	62496	55	BP1200-S/S	76343	140	CART-36/900-S/S	78578	53	CART2-120/3000-S/S	78588	102
ACME-PRK	62496	55	BP1400	73113	140	CART-36/900-S/S	78578	79	CART2-126/3150-S/S	78640	48
AIR BAG P	62036	55	BP1400-B	73782	140	CART-36/900-S/S	78578	81	CART2-126/3150-S/S	78640	54
AIR HARK-S/S-60	62035	55	BP1400-HD-B	73302	140	CART-36/900-S/S	78578	86	CART2-48/1200-S/S	78580	47
AIR HARK-S/S-73	64175	55	BP1400-S/S	76344	140	CART-36/900-S/S	78578	88	CART2-48/1200-S/S	78580	53
AIR HDMRK S/S	62034	55	BP1500	73114	140	CART-36/900-S/S	78578	93	CART2-60/1500-S/S	78584	48
ATV-ANGLE	62426	69	BP1500-1600-PL	73119	140	CART-36/900-S/S	78578	95	CART2-60/1500-S/S	78584	54
ATV-ANGLE	62426	74	BP1500-1600-PL-S/S	A0647	140	CART-36/900-S/S	78578	100	CART2-60/1500-S/S	78584	79
ATV-ANGLE	62426	94	BP1500-B	73783	140	CART-36/900-S/S	78578	101	CART2-60/1500-S/S	78584	81
ATV-BAG	62036	69	BP1500-HD-B	73303	140	CART-42/1050-S/S	78579	47	CART2-60/1500-S/S	78584	86
ATV-BAG	62036	74	BP1500-S/S	76345	140	CART-42/1050-S/S	78579	53	CART2-60/1500-S/S	78584	88
ATV-BAG	62036	94	BP1600	73115	140	CART-42/1050-S/S	78579	79	CART2-60/1500-S/S	78584	93
ATV-MOUNT	62424	69	BP1600-B	73784	140	CART-42/1050-S/S	78579	81	CART2-60/1500-S/S	78584	95
ATV-MOUNT	63073	69	BP1600-HD-B	73304	140	CART-42/1050-S/S	78579	86	CART2-60/1500-S/S	78584	100
ATV-MOUNT	62424	74	BP1600-S/S	76346	140	CART-42/1050-S/S	78579	88	CART2-60/1500-S/S	78584	102
ATV-MOUNT	63073	74	BP1800	73117	140	CART-42/1050-S/S	78579	93	CART2-66/1650-S/S	78634	48
ATV-MOUNT	62424	94	BP1800-B	73785	140	CART-42/1050-S/S	78579	95	CART2-66/1650-S/S	78634	54
ATV-MOUNT	63073	94	BP1800-HD-B	73306	140	CART-42/1050-S/S	78579	100	CART2-72/1800-S/S	78585	48
ATV-NIP	62037	55	BP1800-PL	73121	140	CART-42/1050-S/S	78579	101	CART2-72/1800-S/S	78585	54
ATV-NIP	62037	69	BP1800-PL-S/S	A1547	140	CART-48/1200-S/S	78580	79	CART2-72/1800-S/S	78585	79
ATV-NIP	62037	74	BP1800-S/S	76347	140	CART-48/1200-S/S	78580	81	CART2-72/1800-S/S	78585	81
ATV-NIP	62037	94	BP2000-HD-B	73307	140	CART-48/1200-S/S	78580	86	CART2-72/1800-S/S	78585	86
ATV-SLIDE	62425	69	BP2200-HD-B	73308	140	CART-48/1200-S/S	78580	88	CART2-72/1800-S/S	78585	88
ATV-SLIDE	62425	74	BP2400-HD-B	73309	140	CART-48/1200-S/S	78580	93	CART2-72/1800-S/S	78585	93
ATV-SLIDE	62425	94	BP2500-HD-B	73311	140	CART-48/1200-S/S	78580	95	CART2-72/1800-S/S	78585	95
ATVK-60	62409	69	BP450	73102	140	CART-48/1200-S/S	78580	100	CART2-72/1800-S/S	78585	100
ATVK-60	62409	74	BP450-750-PL	73109	140	CART-48/1200-S/S	78580	101	CART2-72/1800-S/S	78585	102
ATVK-60	62409	94	BP450-750-PL-S/S	A0683	140	CART-54/1350-S/S	78581	79	CART2-78/1950-S/S	78635	48
ATVK-73	63072	69	BP450-B	74055	140	CART-54/1350-S/S	78581	81	CART2-78/1950-S/S	78635	54
ATVK-73	63072	74	BP450-S/S	76337	140	CART-54/1350-S/S	78581	86	CART2-78/1950-S/S	78635	79
ATVK-73	63072	94	BP600	73104	140	CART-54/1350-S/S	78581	88	CART2-78/1950-S/S	78635	81
AWT	75904	26	BP600-B	73777	140	CART-54/1350-S/S	78581	93	CART2-78/1950-S/S	78635	86
AWT	75904	32	BP600-S/S	76338	140	CART-54/1350-S/S	78581	95	CART2-78/1950-S/S	78635	88
AWT-1S	76375	26	BP750	73106	140	CART-54/1350-S/S	78581	100	CART2-78/1950-S/S	78635	93
AWT-1S	76375	32	BP750-B	73778	140	CART-54/1350-S/S	78581	101	CART2-78/1950-S/S	78635	95
AWTA	75907	26	BP750-HD-B	A0223	140	CART-60/1500-S/S	78582	47	CART2-78/1950-S/S	78635	100
AWTA	75907	32	BP750-S/S	76339	140	CART-60/1500-S/S	78582	53	CART2-78/1950-S/S	78635	102
AWTB	75905	26	BP800	73107	140	CART-60/1500-S/S	78582	79	CART2-84/2100-S/S	78586	48
AWTB	75905	32	BP800-1050-PL	73111	140	CART-60/1500-S/S	78582	81	CART2-84/2100-S/S	78586	54
AWTCB	75908	26	BP800-1050-PL-S/S	A0613	140	CART-60/1500-S/S	78582	86	CART2-84/2100-S/S	78586	79
AWTCB	75908	32	BP800-B	74057	140	CART-60/1500-S/S	78582	88	CART2-84/2100-S/S	78586	81
AWTHK	75909	26	BP800-S/S	76340	140	CART-60/1500-S/S	78582	93	CART2-84/2100-S/S	78586	86
AWTHK	75909	32	BP900	73108	140	CART-60/1500-S/S	78582	95	CART2-84/2100-S/S	78586	88
AWTMB	75906	26	BP900-B	73779	140	CART-60/1500-S/S	78582	100	CART2-84/2100-S/S	78586	93
AWTMB	75906	32	BP900-HD-B	A0224	140	CART-60/1500-S/S	78582	101	CART2-84/2100-S/S	78586	95
AWTNCB	76069	26	BP900-S/S	76341	140	CART-72/1800-S/S	78583	47	CART2-84/2100-S/S	78586	100

INDEX By Ordering Number

Ordering Number	Item Code	Page #	Ordering Number	Item Code	Page #	Ordering Number	Item Code	Page #	Ordering Number	Item Code	Page #
CART2-84/2100-S/S	78586	102	CBD-ST-TB-S/S	A2629	146	CCKTS-S/S	79234	66	CRB-LS40HT	77556	14
CART2-96/2400-S/S	78587	48	CBD-ST-XL	61051	146	CCMK	78919	64	CRB-LS40W	77102	14
CART2-96/2400-S/S	78587	54	CBD-ST-XL-B	A1784	146	CCMK	78919	66	CRB-LS46	77094	14
CART2-96/2400-S/S	78587	79	CBD-ST-XL-B	A1784	146	CCMK-S/S	78921	64	CRB-LS46HT	77557	14
CART2-96/2400-S/S	78587	81	CBD-ST-XL-B-P	64482	146	CCMK-S/S	78921	66	CRB-LS46W	77103	14
CART2-96/2400-S/S	78587	86	CBD-ST-XL-B-P	64482	146	CCMKHD	78920	64	CRB-LS52	77095	14
CART2-96/2400-S/S	78587	88	CBD-ST-XL-FP	61114	146	CCMKHD	78920	66	CRB-LS52HT	77558	14
CART2-96/2400-S/S	78587	93	CBD-ST-XL-FP	61114	146	CCMKHD	78920	71	CRB-LS52W	77104	14
CART2-96/2400-S/S	78587	95	CBD-ST-XL-MF	61107	146	CCMKHD-S/S	78922	64	CRB-LS58	77096	14
CART2-96/2400-S/S	78587	100	CBD-ST-XL-MF-S/S	61110	146	CCMKHD-S/S	78922	66	CRB-LS58HT	77559	14
CART2-96/2400-S/S	78587	102	CBD-ST-XL-P	64774	146	CCMKHD-S/S	78922	71	CRB-LS58W	77105	14
CBC18	76668	114	CBD-ST-XL-P-S/S	64625	146	CDS18	76684	114	CRB-W16	78472	19
CBC24	76669	114	CBD-ST-XL-PS	64778	146	CDS24	76685	114	CRB-W22	78473	19
CBC30	76670	114	CBD-ST-XL-PS-S/S	64782	146	CDS30	76686	114	CRB-W28	78474	19
CBC36	76671	114	CBD-ST-XL-S	63024	146	CDS36	76687	114	CRB-W34	78475	19
CBC42	76672	114	CBD-ST-XL-S	63024	146	CDS42	76688	114	CRB-W40	78476	19
CBC48	76673	114	CBD-ST-XL-S/S	A2138	146	CDS48	76689	114	CRB-W46	78477	19
CBC54	76674	114	CBD-ST-XXL	63747	146	CDS54	76690	114	CRB-W52	78478	19
CBC60	76675	114	CBD-ST-XXL-B	63752	146	CDS60	76691	114	CRB-W58	78479	19
CBD-L	76444	145	CBD-ST-XXL-B	63752	146	CEBC-1	30018	162	CRB-W64	78480	19
CBD-M	76443	145	CBD-ST-XXL-B-P	64622	146	CEBC-2	30019	162	CRB-W70	78481	19
CBD-S	76442	145	CBD-ST-XXL-B-P	64622	146	CFG-212	78838	15	CRB16	75629	19
CBD-ST-AA	61096	146	CBD-ST-XXL-FP	63751	146	CFG-218	78839	15	CRB22	75630	19
CBD-ST-AA-S/S	61097	146	CBD-ST-XXL-FP	63751	146	CFG-224	78840	15	CRB28	75631	19
CBD-ST-B	61111	146	CBD-ST-XXL-MF	63749	146	CFG-230	78841	15	CRB34	75632	19
CBD-ST-B	61111	146	CBD-ST-XXL-MF-S/S	63750	146	CFG-236	78842	15	CRB40	75633	19
CBD-ST-B-P	64620	146	CBD-ST-XXL-P	64775	146	CFG-242	78843	15	CRB46	75634	19
CBD-ST-B-P	64620	146	CBD-ST-XXL-P-S/S	64626	146	CFG-248	78844	15	CRB52	75635	19
CBD-ST-BB	64310	146	CBD-ST-XXL-PS	64779	146	CFG-254	78845	15	CRB58	75636	19
CBD-ST-BB	64310	146	CBD-ST-XXL-PS-S/S	64783	146	CFG-260	78846	15	CRB64	75775	19
CBD-ST-CS-S/S	A2215	146	CBD-ST-XXL-S	63791	146	CFG-272	78847	15	CRB70	75773	19
CBD-ST-CS-S/S	A2215	146	CBD-ST-XXL-S	63791	146	CLSFG-212	77144	10	CRD18	76676	114
CBD-ST-HN-S/S	61100	146	CBD-ST-XXL-S/S	63748	146	CLSFG-218	77145	10	CRD24	76677	114
CBD-ST-HN-S/S	61100	146	CBD-XL	76445	145	CLSFG-224	77146	10	CRD30	76678	114
CBD-ST-L	61050	146	CBR-L	72485	145	CLSFG-230	77147	10	CRD36	76679	114
CBD-ST-L-B	A2218	146	CBR-M	72484	145	CLSFG-236	77148	10	CRD42	76680	114
CBD-ST-L-B	A2218	146	CBR-S	72483	145	CLSFG-242	77149	10	CRD48	76681	114
CBD-ST-L-B-P	64621	146	CBR-XL	72486	145	CLSFG-248	77150	10	CRD54	76682	114
CBD-ST-L-B-P	64621	146	CCKHDL	79225	64	CLSFG-254	77151	10	CRD60	76683	114
CBD-ST-L-FP	61113	146	CCKHDL	79225	66	CLSFG-260	77152	10	CRDLBLK-LH-S/S	A2826	82
CBD-ST-L-FP	61113	146	CCKHDL	79225	71	CPB	76692	114	CRDLBLK-LH-S/S	A2826	89
CBD-ST-L-MF	61106	146	CCKHDL-S/S	79227	64	CRB-HT10	76593	19	CRDLBLK-LH-S/S	A2826	102
CBD-ST-L-MF-S/S	61109	146	CCKHDL-S/S	79227	66	CRB-HT16	76594	19	CRDLBLK-RH-S/S	A2825	82
CBD-ST-L-P	64773	146	CCKHDL-S/S	79227	71	CRB-HT22	76595	19	CRDLBLK-RH-S/S	A2825	89
CBD-ST-L-P-S/S	64624	146	CCKHDR	79229	64	CRB-HT28	76596	19	CRDLBLK-RH-S/S	A2825	102
CBD-ST-L-PS	64777	146	CCKHDR	79229	66	CRB-HT34	76597	19	CRHMK	62400	80
CBD-ST-L-PS-S/S	64781	146	CCKHDR	79229	71	CRB-HT40	76598	19	CRHMK	62400	87
CBD-ST-L-S	64785	146	CCKHDR-S/S	79231	64	CRB-HT46	76599	19	CRHMK	62400	100
CBD-ST-L-S	64785	146	CCKHDR-S/S	79231	66	CRB-HT52	76600	19	CRHMK-S/S	62095	82
CBD-ST-L-S/S	61080	146	CCKHDR-S/S	79231	71	CRB-HT58	76601	19	CRHMK-S/S	62095	89
CBD-ST-M	61077	146	CCKHDS	79233	64	CRB-HT64	76602	19	CRHMK-S/S	62095	102
CBD-ST-M-FP	61112	146	CCKHDS	79233	66	CRB-HT70	76603	19	CST1HDM-B	78515	94
CBD-ST-M-FP	61112	146	CCKHDS	79233	71	CRB-LS10	77088	14	CST1HDM-B-S/S	78392	96
CBD-ST-M-MF	61105	146	CCKHDS-S/S	73235	64	CRB-LS10W	77097	14	CST1HDM-G	78516	94
CBD-ST-M-MF-S/S	61108	146	CCKHDS-S/S	73235	66	CRB-LS16	77089	14	CST1HDM-G-S/S	78393	96
CBD-ST-M-P	64772	146	CCKHDS-S/S	73235	71	CRB-LS16HT	77552	14	CST1HDM-S	78514	94
CBD-ST-M-P-S/S	64623	146	CCKL	79224	64	CRB-LS16W	77098	14	CST1HDM-S-S/S	78391	96
CBD-ST-M-PS-S/S	64780	146	CCKL	79224	66	CRB-LS22	77090	14	CST1HDM-W	78513	94
CBD-ST-M-PSS	64776	146	CCKL-S/S	79226	64	CRB-LS22HT	77553	14	CST1HDM-W-S/S	78390	96
CBD-ST-M-S	64784	146	CCKL-S/S	79226	66	CRB-LS22W	77099	14	CSTAK	77031	94
CBD-ST-M-S	64784	146	CCKR	79228	64	CRB-LS28	77091	14	CSTAK	77031	96
CBD-ST-M-S/S	61079	146	CCKR	79228	66	CRB-LS28HT	77554	14	CSTBK	77037	94
CBD-ST-MC	B0092	146	CCKR-S/S	79230	64	CRB-LS28W	77100	14	CSTBK	77037	96
CBD-ST-MC	A2630	146	CCKR-S/S	79230	66	CRB-LS34	77092	14	CSTHDMK	77871	94
CBD-ST-PB	A2449	146	CCKTS	79232	64	CRB-LS34HT	77555	14	CSTHDMK-S/S	78384	96
CBD-ST-PB	A2449	146	CCKTS	79232	66	CRB-LS34W	77101	14	CSTHDPM	77869	94
CBD-ST-TB-S/S	A2629	146	CCKTS-S/S	79234	64	CRB-LS40	77093	14	CSTHDPM-S/S	78389	96

INDEX By Ordering Number

Ordering Number	Item Code	Page #	Ordering Number	Item Code	Page #	Ordering Number	Item Code	Page #	Ordering Number	Item Code	Page #
CT6	74535	64	DRXH-60-435	76902	137	DRXM-72-420	76855	136	EZCSK-1350	82358	131
CT6	74535	66	DRXH-60-520	76894	137	DRXM-72-435	76871	136	EZCSK-1350	82358	133
CT6	74535	68	DRXH-60-535	76910	137	DRXM-72-520	76863	136	EZCSK-1500	82359	127
CT6	74535	71	DRXH-72-420	76887	137	DRXM-72-535	76879	136	EZCSK-1500	82359	129
CT6	74535	73	DRXH-72-435	76903	137	EBC-1	30001	162	EZCSK-1500	82359	131
CT6	74535	80	DRXH-72-520	76895	137	EBC-1-B	30003	162	EZCSK-1500	82359	133
CT6	74535	82	DRXH-72-535	76911	137	EBC-2	30002	162	EZCSK-1800	82360	127
CT6	74535	87	DRXL-24-420	76816	135	EBC-2-B	30004	162	EZCSK-1800	82360	129
CT6	74535	89	DRXL-24-435	76832	135	EBC1-RK	30033	162	EZCSK-1800	82360	131
CT6	74535	93	DRXL-24-520	76824	135	EBC2-RK	30034	162	EZCSK-1800	82360	133
CT6	74535	96	DRXL-24-535	76840	135	ESBK-B	76411	17	EZCSK-600	82353	127
CT6 (C-Tip)	74535	77	DRXL-30-420	76817	135	ESBK-PS	76410	17	EZCSK-600	82353	129
CT6 (C-Tip)	74535	84	DRXL-30-435	76833	135	ESPBK	76408	17	EZCSK-600	82353	131
CT6 (C-Tip)	74535	91	DRXL-30-520	76825	135	ESPRK	76409	17	EZCSK-600	82353	133
CTS-B	77744	94	DRXL-30-535	76841	135	ESPSBK	76407	17	EZCSK-750	82354	127
CTS-B-S/S	78387	13	DRXL-36-420	76818	135	ESS-B	76413	17	EZCSK-750	82354	129
CTS-B-S/S	78387	96	DRXL-36-435	76834	135	ESS-S	76412	17	EZCSK-750	82354	131
CTS-G	77745	94	DRXL-36-520	76826	135	ESS-S	76412	107	EZCSK-750	82354	133
CTS-G-S/S	78388	96	DRXL-36-535	76842	135	ESS-S-S/S	79288	108	EZCSK-900	82355	127
CTS-S	77743	61	DRXL-42-420	76819	135	EST-B	76405	17	EZCSK-900	82355	129
CTS-S	77743	94	DRXL-42-435	76835	135	EST-G-S/S	78810	18	EZCSK-900	82355	131
CTS-S-S/S	78386	96	DRXL-42-520	76827	135	EST-P	76403	17	EZCSK-900	82355	133
CTS-W	77742	94	DRXL-42-535	76843	135	EST-P-S/S	78808	18	EZIB 1050-1200L	82220	130
CTS-W-S/S	78385	96	DRXL-48-420	76820	135	EST-S	76404	17	EZIB 1050-1200M	82236	132
DBK-L	76448	145	DRXL-48-435	76836	135	EST-W-S/S	78809	18	EZIB 1050-1500L	82228	130
DBK-M	76447	145	DRXL-48-520	76828	135	ESTAK	76406	17	EZIB 1050-1500M	82244	132
DBK-S	76446	145	DRXL-48-535	76844	135	ESTAK	76406	107	EZIB 1200-1200L	82221	130
DBK-XL	76449	145	DRXL-54-420	76821	135	ESTAK-EST	76406	55	EZIB 1200-1200M	82237	132
DRXD-42-520	76912	138	DRXL-54-435	76837	135	ESTAK-EST-S/S	78849	18	EZIB 1200-1500L	82229	130
DRXD-42-535	76919	138	DRXL-54-520	76829	135	ESTAK-EST-S/S	78849	55	EZIB 1200-1500M	82245	132
DRXD-48-520	76913	138	DRXL-54-535	76845	135	ESTAK-SS	78849	108	EZIB 1350-1200L	82222	130
DRXD-48-535	76920	138	DRXL-60-420	76822	135	EZAI-1050	82413	126	EZIB 1350-1200M	82238	132
DRXD-54-520	76914	138	DRXL-60-435	76838	135	EZAI-1200	82414	126	EZIB 1350-1500L	82230	130
DRXD-54-535	76921	138	DRXL-60-520	76830	135	EZAI-1350	82415	126	EZIB 1350-1500M	82246	132
DRXD-60-520	76915	138	DRXL-60-535	76846	135	EZAI-1500	82416	126	EZIB 1500-1200L	82223	130
DRXD-60-535	76922	138	DRXL-72-420	76823	135	EZAI-1800	82417	126	EZIB 1500-1200M	82239	132
DRXD-72-520	76916	138	DRXL-72-435	76839	135	EZAI-600	82410	126	EZIB 1500-1500L	82231	130
DRXD-72-535	76923	138	DRXL-72-520	76831	135	EZAI-750	82411	126	EZIB 1500-1500M	82247	132
DRXD-84-520	76917	138	DRXL-72-535	76847	135	EZAI-900	82412	126	EZIB 1800-1200L	82224	130
DRXD-84-535	76924	138	DRXM-24-420	76848	136	EZBMK-1050	82284	131	EZIB 1800-1200M	82240	132
DRXD-96-520	76918	138	DRXM-24-435	76864	136	EZBMK-1050	82284	133	EZIB 1800-1500L	82232	130
DRXD-96-535	76925	138	DRXM-24-520	76856	136	EZBMK-1200	82285	131	EZIB 1800-1500M	82248	132
DRXH-24-420	76880	137	DRXM-24-535	76872	136	EZBMK-1200	82285	133	EZIB600-1200L	82217	130
DRXH-24-435	76896	137	DRXM-30-420	76849	136	EZBMK-1350	82286	131	EZIB600-1200M	82233	132
DRXH-24-520	76888	137	DRXM-30-435	76865	136	EZBMK-1350	82286	133	EZIB600-1500L	82225	130
DRXH-24-535	76904	137	DRXM-30-520	76857	136	EZBMK-1500	82287	131	EZIB600-1500M	82241	132
DRXH-30-420	76881	137	DRXM-30-535	76873	136	EZBMK-1500	82287	133	EZIB750-1200L	82218	130
DRXH-30-435	76897	137	DRXM-36-420	76850	136	EZBMK-1800	82288	131	EZIB750-1200M	82234	132
DRXH-30-520	76889	137	DRXM-36-435	76866	136	EZBMK-1800	82288	133	EZIB750-1500L	82226	130
DRXH-30-535	76905	137	DRXM-36-520	76858	136	EZBMK-600	82281	131	EZIB750-1500M	82242	132
DRXH-36-420	76882	137	DRXM-36-535	76874	136	EZBMK-900	82281	133	EZIB900-1200L	82219	130
DRXH-36-435	76898	137	DRXM-42-420	76851	136	EZBMK-750	82282	131	EZIB900-1200M	82235	132
DRXH-36-520	76890	137	DRXM-42-435	76867	136	EZBMK-750	82282	133	EZIB900-1500L	82227	130
DRXH-36-535	76906	137	DRXM-42-520	76859	136	EZBMK-900	82283	133	EZIB900-1500M	82243	132
DRXH-42-420	76883	137	DRXM-42-535	76875	136	EZBMK-9000	82283	131	EZP-LS212	77127	10
DRXH-42-435	76899	137	DRXM-48-420	76852	136	EZBS-1200	82361	131	EZP-LS212-S/S	62836	10
DRXH-42-520	76891	137	DRXM-48-435	76868	136	EZBS-1500	82362	131	EZP-LS212HT	77746	10
DRXH-42-535	76907	137	DRXM-48-520	76860	136	EZCSK-1050	82356	127	EZP-LS212HT-S/S	62845	10
DRXH-48-420	76884	137	DRXM-48-535	76876	136	EZCSK-1050	82356	129	EZP-LS218	77128	10
DRXH-48-435	76900	137	DRXM-54-420	76853	136	EZCSK-1050	82356	131	EZP-LS218-S/S	62837	10
DRXH-48-520	76892	137	DRXM-54-435	76869	136	EZCSK-1050	82356	133	EZP-LS218HT	77747	10
DRXH-48-535	76908	137	DRXM-54-520	76861	136	EZCSK-1200	82357	127	EZP-LS218HT-S/S	62846	10
DRXH-54-420	76885	137	DRXM-54-535	76877	136	EZCSK-1200	82357	129	EZP-LS224	77129	10
DRXH-54-435	76901	137	DRXM-60-420	76854	136	EZCSK-1200	82357	131	EZP-LS224-S/S	62838	10
DRXH-54-520	76893	137	DRXM-60-435	76870	136	EZCSK-1200	82357	133	EZP-LS224HT	77748	10
DRXH-54-535	76909	137	DRXM-60-520	76862	136	EZCSK-1350	82358	127	EZP-LS224HT-S/S	62847	10
DRXH-60-420	76886	137	DRXM-60-535	76878	136	EZCSK-1350	82358	129	EZP-LS230	77130	10

INDEX By Ordering Number

Ordering Number	Item Code	Page #	Ordering Number	Item Code	Page #	Ordering Number	Item Code	Page #	Ordering Number	Item Code	Page #
EZP-LS230-S/S	62839	10	EZP1P54	75626	21	EZWPK-1200	82349	127	FBP1800-B	61786	143
EZP-LS230HT	77749	10	EZP1P54-S/S	61184	18	EZWPK-1200	82349	129	FBP1800-TP	61756	143
EZP-LS230HT-S/S	62848	10	EZP1P60	75627	17	EZWPK-1200	82349	131	FBP1800-TP S/S	61771	143
EZP-LS236	77131	10	EZP1P60	75627	21	EZWPK-1200	82349	133	FBP2000-B	61787	143
EZP-LS236-S/S	62840	10	EZP1P60-S/S	61185	18	EZWPK-1350	82350	127	FBP2000-TP	61757	143
EZP-LS236HT	77750	10	EZP1P72	75772	17	EZWPK-1350	82350	131	FBP2000-TP S/S	61772	143
EZP-LS236HT-S/S	62849	10	EZP1P72	75772	21	EZWPK-1350	82350	133	FBP2200-2400-MF	61799	144
EZP-LS242	77132	10	EZP1P72-S/S	61186	18	EZWPK-13500	82350	129	FBP2200-2400-MF-S/S	61807	144
EZP-LS242-S/S	62841	10	EZP1PL	75641	17	EZWPK-1500	82351	127	FBP2200-2400-PP	61894	144
EZP-LS242HT	77751	10	EZP1PL	75641	21	EZWPK-1500	82351	129	FBP2200-2400-PP-S/S	61902	144
EZP-LS242HT-S/S	62850	10	EZP1PL-S/S	78848	18	EZWPK-1500	82351	131	FBP2200-2400-SP	61910	144
EZP-LS248	77133	10	EZP1T-212	78488	20	EZWPK-1500	82351	133	FBP2200-2400-SP-S/S	61918	144
EZP-LS248-S/S	62842	10	EZP1T-218	78489	20	EZWPK-1800	82352	127	FBP2200-B	61788	143
EZP-LS248HT	77752	10	EZP1T-224	78490	20	EZWPK-1800	82352	129	FBP2200-TP	61758	143
EZP-LS248HT-S/S	62851	10	EZP1T-230	78491	20	EZWPK-1800	82352	131	FBP2200-TP S/S	61773	143
EZP-LS254	77134	10	EZP1T-236	78492	20	EZWPK-1800	82352	133	FBP2400-B	61789	143
EZP-LS254-S/S	62843	10	EZP1T-242	78493	20	EZWPK-600	82345	127	FBP2400-TP	61759	143
EZP-LS254HT	77753	10	EZP1T-248	78494	20	EZWPK-600	82345	129	FBP2400-TP S/S	61774	143
EZP-LS254HT-S/S	62852	10	EZP1T-254	78495	20	EZWPK-600	82345	131	FBP2500-2600-MF	61800	144
EZP-LS260	77135	10	EZP1T-260	78496	20	EZWPK-600	82345	133	FBP2500-2600-MF-S/S	61808	144
EZP-LS260-S/S	62844	10	EZP1T-272	78497	20	EZWPK-750	82346	127	FBP2500-2600-PP	61895	144
EZP-LS260HT	77754	10	EZPTBT	77384	21	EZWPK-750	82346	129	FBP2500-2600-PP-S/S	61903	144
EZP-LS260HT-S/S	62853	10	EZPTBTHD	77385	21	EZWPK-750	82346	131	FBP2500-2600-SP	61911	144
EZP1-218	75611	15	EZPTCK	78508	21	EZWPK-750	82346	133	FBP2500-2600-SP-S/S	61919	144
EZP1-218-S/S	61081	15	EZPTCKHD	78509	21	EZWPK-900	82347	127	FBP2500-B	61790	143
EZP1-224	75612	15	EZPTMPK	78507	21	EZWPK-900	82347	129	FBP2500-TP	61760	143
EZP1-224-S/S	61082	15	EZPTSK	78511	21	EZWPK-900	82347	131	FBP2500-TP S/S	61775	143
EZP1-230	75613	15	EZPTSKHD	78512	21	EZWPK-900	82347	133	FBP2600-B	61791	143
EZP1-230-S/S	61017	15	EZPTSR	78510	21	FBP-FP	61888	144	FBP2600-TP	61761	143
EZP1-236	75614	15	EZRMKM	82344	127	FBP-FP-S/S	61889	144	FBP2600-TP S/S	61776	143
EZP1-236-S/S	61083	15	EZRMKM	82344	129	FBP-LM	61882	144	FBP900-1050-MF	61795	144
EZP1-242	75615	15	EZSB1050-1200C	82188	126	FBP-LM-S/S	61883	144	FBP900-1050-MF-S/S	61803	144
EZP1-242-S/S	61016	15	EZSB1050-1200I	82204	128	FBP-LP	61875	144	FBP900-1050-PP	61890	144
EZP1-248	75616	15	EZSB1050-1500C	82196	126	FBP-NP-S/S	61876	144	FBP900-1050-PP-S/S	61898	144
EZP1-248-S/S	61084	15	EZSB1050-1500I	82212	128	FBP1050-B	61781	143	FBP900-1050-SP	61906	144
EZP1-254	75617	15	EZSB1200-1200C	82189	126	FBP1050-TP	61751	143	FBP900-1050-SP-S/S	61914	144
EZP1-254-S/S	61085	15	EZSB1200-1200I	82205	128	FBP1050-TP S/S	61766	143	FBP900-B	61780	143
EZP1-260	75618	15	EZSB1200-1500C	82197	126	FBP1200-1400-MF	61796	144	FBP900-TP	61750	143
EZP1-260-S/S	61086	15	EZSB1200-1500I	82213	128	FBP1200-1400-MF-S/S	61804	144	FBP900-TP S/S	61765	143
EZP1-272	75771	15	EZSB1350-1200C	82190	126	FBP1200-1400-PP	61891	144	FL-L	76980	162
EZP1-272-S/S	61087	15	EZSB1350-1200I	82206	128	FBP1200-1400-PP-S/S	61899	144	FL-M	76979	162
EZP1BP	75642	17	EZSB1350-1500C	82198	126	FBP1200-1400-SP	61907	144	FL-XL	76983	162
EZP1BP	75642	21	EZSB1350-1500I	82214	128	FBP1200-1400-SP-S/S	61915	144	FLCP	76479	162
EZP1MPK	75637	17	EZSB1500-1200C	82191	126	FBP1200-B	61782	143	FLEL-L	76473	162
EZP1MPK-S/S	78923	18	EZSB1500-1200I	82207	128	FBP1200-TP	61752	143	FLEL-M	76472	162
EZP1P12	75619	17	EZSB1500-1500C	82199	126	FBP1200-TP S/S	61767	143	FLELK-XL	76986	162
EZP1P12	75619	21	EZSB1500-1500I	82215	128	FBP1400-B	61783	143	FLELP	76474	162
EZP1P12-S/S	78812	18	EZSB1800-1200C	82192	126	FBP1400-TP	61753	143	FLRLB-L	76481	162
EZP1P18	75620	17	EZSB1800-1200I	82208	128	FBP1400-TP S/S	61768	143	FLRLB-M	76482	162
EZP1P18	75620	21	EZSB1800-1500C	82200	126	FBP1500-1600-MF	61797	144	FLRP	76478	162
EZP1P18-S/S	61182	18	EZSB1800-1500I	82216	128	FBP1500-1600-MF-S/S	61805	144	FLSC-CP	71057	160
EZP1P24	75621	17	EZSB600-1200C	82185	126	FBP1500-1600-PP	61892	144	FLSC-CP-S/S	A1438	160
EZP1P24	75621	21	EZSB600-1200I	82201	128	FBP1500-1600-PP-S/S	61900	144	FLSC-TP	71056	160
EZP1P24-S/S	A2988	18	EZSB600-1500C	82193	126	FBP1500-1600-SP	61908	144	FLSC-TP-S/S	A1437	160
EZP1P30	75622	17	EZSB600-1500I	82209	128	FBP1500-1600-SP-S/S	61916	144	FLSC2000	71053	160
EZP1P30	75622	21	EZSB750-1200C	82186	126	FBP1500-B	61784	143	FLSC2000-CB	71061	160
EZP1P30-S/S	A3041	18	EZSB750-1200I	82202	128	FBP1500-TP	61754	143	FLSC2000-CB-S/S	A1439	160
EZP1P36	75623	17	EZSB750-1500C	82194	126	FBP1500-TP S/S	61769	143	FLSC2000-MC	71059	160
EZP1P36	75623	21	EZSB750-1500I	82210	128	FBP1600-B	61785	143	FLSC2000-MC-S/S	A1440	160
EZP1P36-S/S	A3119	18	EZSB900-1200C	82187	126	FBP1600-TP	61755	143	FLSC2000-S/S	A1436	160
EZP1P42	75624	17	EZSB900-1200I	82203	128	FBP1600-TP S/S	61770	143	FLSCM-CP	71140	160
EZP1P42	75624	21	EZSB900-1500C	82195	126	FBP1800-2000-MF	61798	144	FLSCM-CP-S/S	a2596	160
EZP1P42-S/S	61183	18	EZSB900-1500I	82211	128	FBP1800-2000-MF-S/S	61806	144	FLSCM2000	71148	160
EZP1P48	75625	17	EZWPK-1050	82348	127	FBP1800-2000-PP	61893	144	FLSCM2000-S/S	61471	160
EZP1P48	75625	21	EZWPK-1050	82348	129	FBP1800-2000-PP-S/S	61901	144	FLTW-L	76477	162
EZP1P48-S/S	61491	18	EZWPK-1050	82348	131	FBP1800-2000-SP	61909	144	FLTW-M	76476	162
EZP1P54	75626	17	EZWPK-1050	82348	133	FBP1800-2000-SP-S/S	61917	144	FLTW-XL	76985	162

INDEX By Ordering Number

Ordering Number	Item Code	Page #	Ordering Number	Item Code	Page #	Ordering Number	Item Code	Page #	Ordering Number	Item Code	Page #
FLVRL-XL	76984	162	H-CARK-1800-CL	62556	44	H-CARK2-1600-CM-EL15	63575	50	H-CARK2-2600-CLL-S/S	62730	46
H CARK-1000-CL-S/S	62660	46	H-CARK-1800-CL-EL15	63651	50	H-CARK2-1600-CM-S/S	62713	46	H-CARK2-2600-CLL-S/S-EL15	63624	52
H CARK-1000-CL-S/S-EL15	63660	52	H-CARK-1800-CM	62555	44	H-CARK2-1600-CM-S/S-EL15	63607	52	H-CARK2-2600-CM	62622	44
H CARK-1000-CM-S/S	62659	46	H-CARK-1800-CM-EL15	63650	50	H-CARK2-1800-CL	62611	44	H-CARK2-2600-CM-EL15	63590	50
H CARK-1000-CM-S/S-EL15	63659	52	H-CARK-1800-CS	62554	44	H-CARK2-1800-CL-EL15	63579	50	H-CARK2-2600-CM-S/S	62728	46
H CARK-1000-CS-S/S	62658	46	H-CARK-1800-CS-EL15	63649	50	H-CARK2-1800-CL-S/S	62717	46	H-CARK2-2600-CM-S/S-EL15	63622	52
H CARK-1000-CS-S/S-EL15	63658	52	H-CARK-600-CL	62538	44	H-CARK2-1800-CL-S/S-EL15	63611	52	H-CARK2-2800-CL	62626	44
H CARK-1200-CL-S/S	62663	46	H-CARK-600-CL-EL15	63633	50	H-CARK2-1800-CLL	62612	44	H-CARK2-2800-CL-EL15	63594	50
H CARK-1200-CL-S/S-EL15	63663	52	H-CARK-600-CM	62537	44	H-CARK2-1800-CLL-EL15	63580	50	H-CARK2-2800-CL-S/S	62732	46
H CARK-1200-CM-S/S	62662	46	H-CARK-600-CM-EL15	63632	50	H-CARK2-1800-CLL-S/S	62718	46	H-CARK2-2800-CL-S/S-EL15	63626	52
H CARK-1200-CM-S/S-EL15	63662	52	H-CARK-600-CS	62536	44	H-CARK2-1800-CLL-S/S-EL15	63612	52	H-CARK2-2800-CLL	62627	44
H CARK-1200-CS-S/S	62661	46	H-CARK-600-CS-EL15	63631	50	H-CARK2-1800-CM	62610	44	H-CARK2-2800-CLL-EL15	63595	50
H CARK-1200-CS-S/S-EL15	63661	52	H-CARK-800-CL	62541	44	H-CARK2-1800-CM-EL15	63578	50	H-CARK2-2800-CLL-S/S	62733	46
H CARK-1400-CL-S/S	62666	46	H-CARK-800-CL-EL15	63636	50	H-CARK2-1800-CM-S/S	62716	46	H-CARK2-2800-CLL-S/S-EL15	63627	52
H CARK-1400-CL-S/S-EL15	63666	52	H-CARK-800-CM	62540	44	H-CARK2-1800-CM-S/S	62716	46	H-CARK2-2800-CM	62625	44
H CARK-1400-CM-S/S	62665	46	H-CARK-800-CM-EL15	63635	50	H-CARK2-1800-CM-S/S-EL15	63610	52	H-CARK2-2800-CM-EL15	63593	50
H CARK-1400-CM-S/S-EL15	63665	52	H-CARK-800-CS	62539	44	H-CARK2-2000-CL	62614	44	H-CARK2-2800-CM-S/S	62731	46
H CARK-1400-CS-S/S	62664	46	H-CARK-800-CS-EL15	63634	50	H-CARK2-2000-CL-EL15	63582	50	H-CARK2-2800-CM-S/S-EL15	63625	52
H CARK-1400-CS-S/S-EL15	63664	52	H-CARK2-1200-CL	62601	44	H-CARK2-2000-CL-S/S	62720	46	H-CARK2-3000-CL	62629	44
H CARK-1600-CL-S/S	62669	46	H-CARK2-1200-CL-EL15	63569	50	H-CARK2-2000-CL-S/S-EL15	63614	52	H-CARK2-3000-CL-EL15	63597	50
H CARK-1600-CL-S/S-EL15	63669	52	H-CARK2-1200-CL-S/S	62707	46	H-CARK2-2000-CLL	62615	44	H-CARK2-3000-CL-S/S	62735	46
H CARK-1600-CM-S/S	62668	46	H-CARK2-1200-CL-S/S-EL15	63601	52	H-CARK2-2000-CLL-EL15	63583	50	H-CARK2-3000-CL-S/S-EL15	63629	52
H CARK-1600-CM-S/S-EL15	63668	52	H-CARK2-1200-CLL	62602	44	H-CARK2-2000-CLL-S/S	62721	46	H-CARK2-3000-CLL	62630	44
H CARK-1600-CS-S/S	62667	46	H-CARK2-1200-CLL-EL15	63570	50	H-CARK2-2000-CLL-S/S-EL15	63615	52	H-CARK2-3000-CLL-EL15	63598	50
H CARK-1600-CS-S/S-EL15	63667	52	H-CARK2-1200-CLL-S/S	62708	46	H-CARK2-2000-CM	62613	44	H-CARK2-3000-CLL-S/S	62736	46
H CARK-1800-CL-S/S	62672	46	H-CARK2-1200-CLL-S/S-EL15	63602	52	H-CARK2-2000-CM-EL15	63581	50	H-CARK2-3000-CLL-S/S-EL15	63630	52
H CARK-1800-CL-S/S-EL15	63672	52	H-CARK2-1200-CLL-S/S-EL15	63602	52	H-CARK2-2000-CM-S/S	62719	46	H-CARK2-3000-CM	62628	44
H CARK-1800-CM-S/S	62671	46	H-CARK2-1200-CM	62600	44	H-CARK2-2000-CM-S/S	62719	46	H-CARK2-3000-CM-EL15	63596	50
H CARK-1800-CM-S/S-EL15	63671	52	H-CARK2-1200-CM-EL15	63568	50	H-CARK2-2000-CM-S/S-EL15	63613	52	H-CARK2-3000-CM-S/S	62734	46
H CARK-1800-CS-S/S	62670	46	H-CARK2-1200-CM-S/S	62706	46	H-CARK2-2200-CL	62617	44	H-CARK2-3000-CM-S/S-EL15	63628	52
H CARK-1800-CS-S/S-EL15	63670	52	H-CARK2-1200-CM-S/S-EL15	63600	52	H-CARK2-2200-CL-EL15	63585	50	H-SAC-AP-1000	62454	47
H CARK-600-CL-S/S	62654	46	H-CARK2-1200-CS	62599	44	H-CARK2-2200-CL-S/S	62723	46	H-SAC-AP-1000	62454	48
H CARK-600-CL-S/S-EL15	63654	52	H-CARK2-1200-CS-EL15	63567	50	H-CARK2-2200-CL-S/S-EL15	63617	52	H-SAC-AP-1000	62454	48
H CARK-600-CM-S/S	62653	46	H-CARK2-1200-CS-S/S	62705	46	H-CARK2-2200-CLL	62618	44	H-SAC-AP-1000	62454	48
H CARK-600-CM-S/S-EL15	63653	52	H-CARK2-1200-CS-S/S-EL15	63599	52	H-CARK2-2200-CLL-EL15	63586	50	H-SAC-AP-1000	62454	48
H CARK-600-CS-S/S	62652	46	H-CARK2-1400-CL	62605	52	H-CARK2-2200-CLL-S/S	62724	46	H-SAC-AP-1000	62454	48
H CARK-600-CS-S/S-EL15	63652	52	H-CARK2-1400-CL-EL15	63573	50	H-CARK2-2200-CLL-S/S-EL15	63618	52	H-SAC-AP-1000	62454	48
H CARK-800-CL-S/S	62657	46	H-CARK2-1400-CL-S/S	62711	46	H-CARK2-2200-CM	62616	44	H-SAC-AP-1000	62454	53
H CARK-800-CL-S/S-EL15	63657	52	H-CARK2-1400-CL-S/S-EL15	63605	52	H-CARK2-2200-CM-EL15	63584	50	H-SAC-AP-1000	62454	54
H CARK-800-CM-S/S	62656	46	H-CARK2-1400-CLL	62606	44	H-CARK2-2200-CM-S/S	62722	46	H-SAC-AP-1000	62454	54
H CARK-800-CM-S/S-EL15	63656	52	H-CARK2-1400-CLL-EL15	63574	50	H-CARK2-2200-CM-S/S-EL15	63616	52	H-SAC-AP-1000	62454	54
H CARK-800-CS-S/S	62655	46	H-CARK2-1400-CLL-S/S	62712	46	H-CARK2-2400-CL	62620	44	H-SAC-AP-1000	62454	54
H CARK-800-CS-S/S-EL15	63655	52	H-CARK2-1400-CLL-S/S-EL15	63606	52	H-CARK2-2400-CL-EL15	63588	50	H-SAC-AP-1000	62454	54
H-CARK-1000-CL	62544	44	H-CARK2-1400-CM	62604	44	H-CARK2-2400-CL-S/S	62726	46	H-SAC-AP-1200	62455	47
H-CARK-1000-CL-EL15	63639	50	H-CARK2-1400-CM-EL15	63572	50	H-CARK2-2400-CL-S/S-EL15	63620	52	H-SAC-AP-1200	62455	48
H-CARK-1000-CM	62543	44	H-CARK2-1400-CM-S/S	62710	46	H-CARK2-2400-CLL	62621	44	H-SAC-AP-1200	62455	48
H-CARK-1000-CM-EL15	63638	50	H-CARK2-1400-CM-S/S-EL15	63604	52	H-CARK2-2400-CLL-EL15	63589	50	H-SAC-AP-1200	62455	48
H-CARK-1000-CS	62542	44	H-CARK2-1400-CS	62603	44	H-CARK2-2400-CLL-S/S	62727	46	H-SAC-AP-1200	62455	53
H-CARK-1000-CS-EL15	63637	50	H-CARK2-1400-CS-EL15	63571	50	H-CARK2-2400-CLL-S/S-EL15	63621	52	H-SAC-AP-1200	62455	54
H-CARK-1200-CL	62547	44	H-CARK2-1400-CS-S/S	62709	46	H-CARK2-2400-CM	62619	44	H-SAC-AP-1200	62455	54
H-CARK-1200-CL-EL15	63642	50	H-CARK2-1400-CS-S/S-EL15	63603	52	H-CARK2-2400-CM-EL15	63587	50	H-SAC-AP-1200	62455	54
H-CARK-1200-CM	62546	44	H-CARK2-1600-CL	62608	44	H-CARK2-2400-CM-S/S	62725	46	H-SAC-AP-1200	62455	54
H-CARK-1200-CM-EL15	63641	50	H-CARK2-1600-CL-EL15	63576	50	H-CARK2-2400-CM-S/S-EL15	63619	52	H-SAC-AP-1200	62455	54
H-CARK-1200-CS	62545	44	H-CARK2-1600-CL-S/S	62714	46	H-CARK2-2600-CL	62623	44	H-SAC-AP-1400	62456	47
H-CARK-1200-CS-EL15	63640	50	H-CARK2-1600-CL-S/S-EL15	63608	52	H-CARK2-2600-CL-EL15	63591	50	H-SAC-AP-1400	62456	48
H-CARK-1400-CL	62550	44	H-CARK2-1600-CLL	62609	44	H-CARK2-2600-CL-S/S	62729	46	H-SAC-AP-1400	62456	48
H-CARK-1400-CL-EL15	63645	50	H-CARK2-1600-CLL-EL15	63577	50	H-CARK2-2600-CL-S/S-EL15	63623	52	H-SAC-AP-1400	62456	48
H-CARK-1400-CM	62549	44	H-CARK2-1600-CLL-S/S	62715	46	H-CARK2-2600-CLL	62624	44	H-SAC-AP-1400	62456	53
H-CARK-1400-CM-EL15	63644	50	H-CARK2-1600-CLL-S/S-EL15	63609	52	H-CARK2-2600-CLL-EL15	63592	50	H-SAC-AP-1400	62456	54
H-CARK-1400-CS	62548	44	H-CARK2-1600-CM	62607	44						
H-CARK-1400-CS-EL15	63643	50									
H-CARK-1600-CL	62553	44									
H-CARK-1600-CL-EL15	63648	50									
H-CARK-1600-CM	62552	44									
H-CARK-1600-CM-EL15	63647	50									
H-CARK-1600-CS	62551	44									
H-CARK-1600-CS-EL15	63646	50									

INDEX By Ordering Number

Ordering Number	Item Code	Page #	Ordering Number	Item Code	Page #	Ordering Number	Item Code	Page #	Ordering Number	Item Code	Page #
H-SAC-AP-1400	62456	54	H2CP-3000-S/S	62809	48	HBP-TP-900 S/S	A2474	141	HBP2400-MF-TP-S/S	A2513	142
H-SAC-AP-1400	62456	54	H2CP-3000-S/S	62809	54	HBP1050-B-TP	A2317	142	HBP2400-PL-TP	A2302	142
H-SAC-AP-1400	62456	54	H60CSK-B	62747	55	HBP1050-MF-TP	A2306	142	HBP2400-PL-TP-S/S	A2501	142
H-SAC-AP-1400	62456	54	H60CSK-B-S/S	62748	55	HBP1050-MF-TP-S/S	A2505	142	HBP2400-PL-TP-S/S	A2501	142
H-SAC-AP-1400	62456	54	H60CSK-G	62741	55	HBP1050-PL-TP	A2295	142	HBP2400-PL-TP-S/S	A2501	144
H-SAC-AP-1600	62457	47	H60CSK-G-S/S	62742	55	HBP1050-PL-TP	A2295	144	HBP2400-TP	A2292	141
H-SAC-AP-1600	62457	48	H73BTK	63079	47	HBP1050-PL-TP-S/S	A2493	142	HBP2500-B-TP	A2326	142
H-SAC-AP-1600	62457	53	H73BTK	63079	48	HBP1050-PL-TP-S/S	A2493	144	HBP2500-MF-TP	A2315	142
H-SAC-AP-1600	62457	54	H73BTK	63079	53	HBP1050-TP	A2284	141	HBP2500-MF-TP-S/S	A2514	142
H-SAC-AP-1800	62458	47	H73BTK	63079	54	HBP1200-B-TP	A2318	142	HBP2500-PL-TP	A2304	142
H-SAC-AP-1800	62458	53	H73BTK-S/S	63080	47	HBP1200-MF-TP	A2307	142	HBP2500-PL-TP	A2304	144
H-SAC-AP-600	62452	47	H73BTK-S/S	63080	48	HBP1200-MF-TP-S/S	A2506	142	HBP2500-PL-TP-S/S	A2502	142
H-SAC-AP-600	62452	48	H73BTK-S/S	63080	53	HBP1200-PL-TP	A2296	142	HBP2500-PL-TP-S/S	A2502	144
H-SAC-AP-600	62452	48	H73BTK-S/S	63080	54	HBP1200-PL-TP	A2296	144	HBP2500-TP	A2293	141
H-SAC-AP-600	62452	48	H73CSK-B	62749	42	HBP1200-PL-TP-S/S	A2494	142	HBP2600-PL-TP	A0151	144
H-SAC-AP-600	62452	53	H73CSK-B	62749	47	HBP1200-PL-TP-S/S	A2494	144	HBP2600-PL-TP-S/S	61877	144
H-SAC-AP-600	62452	54	H73CSK-B	62749	48	HBP1200-TP	A2285	141	HBP900-B-TP	A2316	142
H-SAC-AP-600	62452	54	H73CSK-B	62749	53	HBP1400-B-TP	A2319	142	HBP900-MF-TP	A2305	142
H-SAC-AP-600	62452	54	H73CSK-B	62749	54	HBP1400-MF-TP	A2308	142	HBP900-MF-TP-S/S	A2504	142
H-SAC-AP-600	62452	54	H73CSK-B	62749	55	HBP1400-MF-TP-S/S	A2507	142	HBP900-PL-TP	A2294	142
H-SAC-AP-600	62452	54	H73CSK-B-S/S	62750	42	HBP1400-PL-TP	A2297	142	HBP900-PL-TP	A2294	144
H-SAC-AP-800	62453	47	H73CSK-B-S/S	62750	47	HBP1400-PL-TP	A2297	144	HBP900-PL-TP-S/S	A2492	142
H-SAC-AP-800	62453	48	H73CSK-B-S/S	62750	48	HBP1400-PL-TP-S/S	A2495	142	HBP900-PL-TP-S/S	A2492	144
H-SAC-AP-800	62453	48	H73CSK-B-S/S	62750	53	HBP1400-PL-TP-S/S	A2495	144	HBP900-TP	A2283	141
H-SAC-AP-800	62453	48	H73CSK-B-S/S	62750	54	HBP1400-TP	A2286	141	HBRK	73068	42
H-SAC-AP-800	62453	48	H73CSK-B-S/S	62750	55	HBP1500-B-TP	A2320	142	HBRK-S/S	75422	42
H-SAC-AP-800	62453	53	H73CSK-G	62743	42	HBP1500-MF-TP	A2309	142	HBRK-S/S-73	76246	55
H-SAC-AP-800	62453	54	H73CSK-G	62743	47	HBP1500-MF-TP-S/S	A2508	142	HBRK-S/S-60	75422	55
H-SAC-AP-800	62453	54	H73CSK-G	62743	48	HBP1500-PL-TP	A2298	142	HBRKX	74549	42
H-SAC-AP-800	62453	54	H73CSK-G	62743	53	HBP1500-PL-TP	A2298	144	HBRKX-S/S	76246	42
H-SAC-AP-800	62453	54	H73CSK-G	62743	54	HBP1500-PL-TP-S/S	A2496	142	HCP-1000	62753	47
H-SAC-AP-800	62453	54	H73CSK-G	62743	55	HBP1500-PL-TP-S/S	A2496	144	HCP-1000	62753	53
H-SAC-AP-800	62453	54	H73CSK-G-S/S	62744	42	HBP1500-TP	A2287	141	HCP-1000-S/S	62759	47
H2CP-1200	62763	48	H73CSK-G-S/S	62744	47	HBP1600-B-TP	A2321	142	HCP-1000-S/S	62759	53
H2CP-1200	62763	54	H73CSK-G-S/S	62744	48	HBP1600-MF-TP	A2310	142	HCP-1200	62754	47
H2CP-1200-S/S	62801	48	H73CSK-G-S/S	62744	53	HBP1600-MF-TP-S/S	A2509	142	HCP-1200	62754	53
H2CP-1200-S/S	62801	54	H73CSK-G-S/S	62744	54	HBP1600-PL-TP	A2299	142	HCP-1200-S/S	62760	47
H2CP-1400	62764	48	H73CSK-G-S/S	62744	55	HBP1600-PL-TP	A2299	144	HCP-1200-S/S	62760	53
H2CP-1400	62764	54	H73CSK-S	62745	48	HBP1600-PL-TP-S/S	A2497	142	HCP-1400	62755	47
H2CP-1400-S/S	62802	48	H73CSK-S	62745	54	HBP1600-PL-TP-S/S	A2497	144	HCP-1400	62755	53
H2CP-1400-S/S	62802	54	H73CSK-S	62745	55	HBP1600-TP	A2288	141	HCP-1400-S/S	62761	47
H2CP-1600	62765	48	H73CSK-S-S/S	62746	48	HBP1800-B-TP	A2322	142	HCP-1400-S/S	62761	53
H2CP-1600	62765	54	H73CSK-S-S/S	62746	54	HBP1800-MF-TP	A2311	142	HCP-1800	62756	47
H2CP-1600-S/S	62803	48	H73CSK-S-S/S	62746	55	HBP1800-MF-TP-S/S	A2510	142	HCP-1800	62756	53
H2CP-1600-S/S	62803	54	HARK	73069	42	HBP1800-PL-TP	A2300	142	HCP-1800-S/S	62762	47
H2CP-1800	62766	48	HARK	73069	107	HBP1800-PL-TP	A2300	144	HCP-1800-S/S	62762	53
H2CP-1800	62766	54	HARK-S/S	75423	42	HBP1800-PL-TP-S/S	A2498	142	HCP-600	62751	47
H2CP-1800-S/S	62804	48	HARK-S/S	77364	108	HBP1800-PL-TP-S/S	A2498	144	HCP-600	62751	53
H2CP-1800-S/S	62804	54	HATDMK-S/S	63861	55	HBP1800-TP	A2289	141	HCP-600-S/S	62757	47
H2CP-2000	62767	48	HBP-LA-TP	A2330	142	HBP2000-B-TP	A2323	142	HCP-600-S/S	62757	53
H2CP-2000	62767	54	HBP-LA-TP-S/S	A2515	142	HBP2000-MF-TP	A2312	142	HCP-800	62752	47
H2CP-2000-S/S	62805	48	HBP-MB-TP	73922	142	HBP2000-MF-TP-S/S	A2511	142	HCP-800	62752	53
H2CP-2000-S/S	62805	54	HBP-MB-TP	73922	144	HBP2000-PL-TP	A2301	142	HCP-800-S/S	62758	47
H2CP-2400	62768	48	HBP-MB-TP-S/S	A1155	142	HBP2000-PL-TP	A2301	144	HCP-800-S/S	62758	53
H2CP-2400	62768	54	HBP-MB-TP-S/S	A1155	144	HBP2000-PL-TP-S/S	A2499	142	HCSBB-60	62513	55
H2CP-2400-S/S	62806	48	HBP-SC-TP	74490	142	HBP2000-PL-TP-S/S	A2499	144	HCSBB-60	62513	55
H2CP-2400-S/S	62806	54	HBP-SC-TP-S/S	A2189	142	HBP2000-TP	A2290	141	HCSBB-73	62514	55
H2CP-2600	62769	48	HBP-TP-1050 S/S	A2475	141	HBP2200-B-TP	A2325	142	HCSBB-73	62514	55
H2CP-2600	62769	54	HBP-TP-1200 S/S	A2476	141	HBP2200-MF-TP	A2314	142	HCSSB-B/G	62589	55
H2CP-2600-S/S	62807	48	HBP-TP-1400 S/S	A2477	141	HBP2200-MF-TP-S/S	A2512	142	HCSSB-B/G	62589	55
H2CP-2600-S/S	62807	54	HBP-TP-1500 S/S	A2478	141	HBP2200-PL-TP	A2303	142	HCSSB-B/G	62589	55
H2CP-2800	62770	48	HBP-TP-1600 S/S	A2479	141	HBP2200-PL-TP	A2303	144	HCSSB-B/G	62589	55
H2CP-2800	62770	54	HBP-TP-1800 S/S	A2480	141	HBP2200-PL-TP-S/S	A2500	142	HCSSB-S	62590	55
H2CP-2800-S/S	62808	48	HBP-TP-2000 S/S	A2481	141	HBP2200-PL-TP-S/S	A2500	144	HCSSB-S	62590	55
H2CP-2800-S/S	62808	54	HBP-TP-2200 S/S	A2482	141	HBP2200-TP	A2291	141	HCSTAK	62494	55
H2CP-3000	62771	48	HBP-TP-2400 S/S	A2483	141	HBP2400-B-TP	A2324	142	HCSTAK-S/S	62495	55
H2CP-3000	62771	54	HBP-TP-2500 S/S	A2484	141	HBP2400-MF-TP	A2313	142	HCSTK-60-B	62747	42

INDEX By Ordering Number

Ordering Number	Item Code	Page #	Ordering Number	Item Code	Page #	Ordering Number	Item Code	Page #	Ordering Number	Item Code	Page #
HCSTK-60-B-S/S	62748	42	HPHD2000	74547	42	HSA8L	73063	40	HV-1200-2SAC-CL-S/S-EL15	63455	51
HCSTK-60-G	62741	42	HPHD2000-S/S	A1783	42	HSA8L-S/S	73774	39	HV-1200-2SAC-CLL	62560	43
HCSTK-60-G-S/S	62742	42	HPHD2400	74548	42	HSA8L-S/S	73774	41	HV-1200-2SAC-CLL-EL15	63424	49
HDARK	74550	42	HPHD2400-S/S	A2590	42	HSA8LL	73064	38	HV-1200-2SAC-CLL-S/S	62676	45
HDARK	77329	107	HPS8	73050	42	HSA8LL	73064	40	HV-1200-2SAC-CLL-S/S-EL15	63456	51
HDARK-S/S	76247	42	HSA	73486	42	HSA8LL-S/S	74033	39	HV-1200-2SAC-CM	62558	43
HDARK-S/S	77331	108	HSA200	73489	38	HSA8LL-S/S	74033	41	HV-1200-2SAC-CM-EL15	63422	49
HDATDMK-S/S	63862	55	HSA200	73489	40	HSA8M	73049	38	HV-1200-2SAC-CM-S/S	62674	45
HDCK	74490	42	HSA200	73489	42	HSA8M	73049	40	HV-1200-2SAC-CM-S/S-EL15	63454	51
HDMK	74551	42	HSA200	73489	43	HSA8M-S/S	73773	39	HV-1200-2SAC-CM-S/S-EL15	62557	43
HDMK-S/S	76248	42	HSA200	73489	47	HSA8M-S/S	73773	41	HV-1200-2SAC-CS	63421	49
HDMRK	74582	42	HSA200	73489	48	HSA8S	73048	38	HV-1200-2SAC-CS-EL15	63427	49
HDMRK	74582	42	HSA200	73489	49	HSA8S	73048	40	HV-1200-2SAC-CS-S/S	62673	45
HDMRK-S/S	76245	42	HSA200	73489	53	HSA8S-S/S	73772	39	HV-1200-2SAC-CS-S/S-EL15	63453	51
HDMRK-S/S	76245	42	HSA200	73489	54	HSA8S-S/S	73772	41	HV-1200-SAC-CL	62526	43
HDR24	79010	121	HSA200-EL15	76027	49	HSA8SS	73047	38	HV-1200-SAC-CL-EL15	63217	49
HDR30	79011	121	HSA200-EL15	76027	53	HSA8SS	73047	40	HV-1200-SAC-CL-S/S	62642	45
HDR36	79012	121	HSA200-EL15	76027	54	HSA8SS-S/S	73771	39	HV-1200-SAC-CL-S/S-EL15	63238	51
HDR42	79013	121	HSA8CL	62507	43	HSA8SS-S/S	73771	41	HV-1200-SAC-CL-S/S-EL15	63238	51
HDR48	79014	121	HSA8CL	62507	47	HSA8SSS	75565	39	HV-1200-SAC-CM	62525	43
HDR54	79015	121	HSA8CL	62507	48	HSA8SSS	75565	41	HV-1200-SAC-CM-EL15	63216	49
HDR60	79016	121	HSA8CL	62507	49	HSHD	73483	42	HV-1200-SAC-CM-S/S	62641	45
HDRBK	79009	121	HSA8CL	62507	53	HSHD	73483	47	HV-1200-SAC-CM-S/S-EL15	63237	51
HDRBK-HD	79072	121	HSA8CL	62507	54	HSHD	73483	48	HV-1200-SAC-CS	62524	43
HDRGEK	79236	121	HSA8CL-S/S	62511	45	HSHD	73483	53	HV-1200-SAC-CS-EL15	63215	49
HDRP17	63679	123	HSA8CL-S/S	62511	47	HSHD	73483	54	HV-1200-SAC-CS-S/S	62640	45
HDRP22	63678	123	HSA8CL-S/S	62511	48	HSHD-S/S	76467	47	HV-1200-SAC-CS-S/S-EL15	63236	51
HDRR24	79019	121	HSA8CL-S/S	62511	51	HSHD-S/S	76467	48	HV-1400-2SAC-CL	62563	43
HDRR30	79020	121	HSA8CL-S/S	62511	53	HSHD-S/S	76467	53	HV-1400-2SAC-CL-EL15	63427	49
HDRR36	79021	121	HSA8CL-S/S	62511	54	HSHD-S/S	76467	54	HV-1400-2SAC-CL-S/S	62679	45
HDRR42	79022	121	HSA8CLL	62508	43	HSTSS	61173	42	HV-1400-2SAC-CL-S/S-EL15	63459	51
HDRR48	79023	121	HSA8CLL	62508	47	HTF212	76658	15	HV-1400-2SAC-CLL	62564	43
HDRR54	79024	121	HSA8CLL	62508	48	HTF212-S/S	62826	15	HV-1400-2SAC-CLL-EL15	63428	49
HDRR60	79025	121	HSA8CLL	62508	49	HTF218	76659	15	HV-1400-2SAC-CLL-S/S	62680	45
HDRRS72*	79026	121	HSA8CLL	62508	53	HTF218-S/S	62827	15	HV-1400-2SAC-CLL-S/S-EL15	63460	51
HDRRS84*	79027	121	HSA8CLL	62508	54	HTF224	76660	15	HV-1400-2SAC-CM	62562	43
HDRS72*	79017	121	HSA8CLL-S/S	62512	45	HTF224-S/S	62828	15	HV-1400-2SAC-CM-EL15	63426	49
HDRS84*	79018	121	HSA8CLL-S/S	62512	47	HTF230	76661	15	HV-1400-2SAC-CM-S/S	62678	45
HDSTCK-S/S	A2189	42	HSA8CLL-S/S	62512	48	HTF230-S/S	62829	15	HV-1400-2SAC-CM-S/S-EL15	63457	51
HDSTKD	A2518	42	HSA8CLL-S/S	62512	51	HTF236	76662	15	HV-1400-SAC-CL	62529	43
HDSTKD-S/S	A2519	42	HSA8CLL-S/S	62512	53	HTF236-S/S	62830	15	HV-1400-SAC-CL-EL15	63220	49
HDS	74502	107	HSA8CLL-S/S	62512	54	HTF242	76663	15	HV-1400-SAC-CL-S/S	62645	45
HDS-S/S	75586	108	HSA8CM	62506	43	HTF242-S/S	62831	15	HV-1400-SAC-CL-S/S-EL15	63241	51
HEX NUT	G1211	55	HSA8CM	62506	47	HTF248	76664	15	HV-1400-SAC-CM	62528	43
HEX NUT	G1211	69	HSA8CM	62506	48	HTF248-S/S	62832	15	HV-1400-SAC-CM-EL15	63219	49
HEX NUT	G1211	74	HSA8CM	62506	49	HTF254	76665	15	HV-1400-SAC-CM-S/S	62644	45
HEX NUT	G1211	94	HSA8CM	62506	53	HTF254-S/S	62833	15	HV-1400-SAC-CL-EL15	63220	49
HMK	73054	42	HSA8CM	62506	54	HTF260	76666	15	HV-1400-SAC-CL-S/S	62645	45
HMK-S/S	75424	42	HSA8CM-S/S	62510	45	HTF260-S/S	62834	15	HV-1400-SAC-CL-S/S-EL15	63241	51
HP1050	73035	42	HSA8CM-S/S	62510	47	HTF272	76667	15	HV-1400-SAC-CM	62528	43
HP1050-S/S	75377	42	HSA8CM-S/S	62510	48	HTF272-S/S	62835	15	HV-1400-SAC-CM-EL15	63219	49
HP1200	73037	42	HSA8CM-S/S	62510	51	HTTS	74141	123	HV-1400-SAC-CM-S/S	62644	45
HP1200-S/S	75378	42	HSA8CM-S/S	62510	53	HV-1000-SAC-CL	62523	43	HV-1400-SAC-CM-S/S-EL15	63240	51
HP1500	73066	42	HSA8CM-S/S	62510	54	HV-1000-SAC-CL-EL15	63214	49	HV-1400-SAC-CS	62527	43
HP1500-S/S	75379	42	HSA8CS	62505	43	HV-1000-SAC-CL-S/S	62639	45	HV-1400-SAC-CS-EL15	63218	49
HP1600	73739	42	HSA8CS	62505	47	HV-1000-SAC-CL-S/S-EL15	63235	51	HV-1400-SAC-CS-S/S	62643	45
HP1600-S/S	75380	42	HSA8CS	62505	48	HV-1000-SAC-CM	62522	43	HV-1400-SAC-CS-S/S-EL15	63239	51
HP450	73027	42	HSA8CS	62505	49	HV-1000-SAC-CM-EL15	63213	49	HV-1600-2SAC-CL	62566	43
HP450-S/S	75373	42	HSA8CS	62505	53	HV-1000-SAC-CM-S/S	62638	45	HV-1600-2SAC-CL-EL15	63430	49
HP600	73029	42	HSA8CS	62505	54	HV-1000-SAC-CM-S/S-EL15	63234	51	HV-1600-2SAC-CL-S/S	62582	45
HP600-S/S	75374	42	HSA8CS-S/S	62509	45	HV-1000-SAC-CS	62521	43	HV-1600-2SAC-CL-S/S-EL15	63462	51
HP750	73031	42	HSA8CS-S/S	62509	47	HV-1000-SAC-CS-EL15	63212	49	HV-1600-2SAC-CLL	62567	43
HP750-S/S	75375	42	HSA8CS-S/S	62509	48	HV-1000-SAC-CS-S/S	62637	45	HV-1600-2SAC-CLL-EL15	63431	49
HP900	73033	42	HSA8CS-S/S	62509	51	HV-1000-SAC-CS-S/S-EL15	63233	51	HV-1600-2SAC-CLL-S/S	62683	45
HP900-S/S	75376	42	HSA8CS-S/S	62509	53	HV-1200-2SAC-CL	62559	43	HV-1600-2SAC-CLL-S/S-EL15	63463	51
HPHD1800	74601	42	HSA8CS-S/S	62509	54	HV-1200-2SAC-CL-EL15	63423	49	HV-1600-2SAC-CM	62565	43
HPHD1800-S/S	A2063	42	HSA8L	73063	38	HV-1200-2SAC-CL-S/S	62675	45	HV-1600-2SAC-CM-EL15	63429	49

INDEX By Ordering Number

Ordering Number	Item Code	Page #	Ordering Number	Item Code	Page #	Ordering Number	Item Code	Page #	Ordering Number	Item Code	Page #
HV-1600-2SAC-CM-S/S	62681	45	HV-2200-2SAC-CM-S/S-EL15	63470	51	HV-800-SAC-CM-S/S-EL15	63231	51	HV2100L-PCST	63967	40
HV-1600-2SAC-CM-S/S-EL15	63461	51	HV-2400-2SAC-CL	62578	43	HV-800-SAC-CS	62518	43	HV2100L-PCST-S/S	64009	41
HV-1600-SAC-CL	62531	43	HV-2400-2SAC-CL-EL15	63442	49	HV-800-SAC-CS-EL15	63209	49	HV2100LL-PCST	63968	40
HV-1600-SAC-CL-EL15	63222	49	HV-2400-2SAC-CL-S/S	62694	45	HV-800-SAC-CS-S/S	62634	45	HV2100LL-PCST-S/S	64010	41
HV-1600-SAC-CL-S/S	62647	45	HV-2400-2SAC-CL-S/S-EL15	63474	51	HV-800-SAC-CS-S/S-EL15	63230	51	HV2100M-PCST	63966	40
HV-1600-SAC-CL-S/S-EL15	63243	43	HV-2400-2SAC-CLL	62579	43	HV1050L	73179	38	HV2100M-PCST-S/S	64008	41
HV-1600-SAC-CLL	62532	43	HV-2400-2SAC-CLL-EL15	63443	49	HV1050L-PCST	63952	40	HV2400L-PCST	63970	40
HV-1600-SAC-CLL-EL15	63223	49	HV-2400-2SAC-CLL-S/S	62695	45	HV1050L-PCST-S/S	63994	41	HV2400L-PCST-S/S	64012	41
HV-1600-SAC-CLL-S/S	62648	45	HV-2400-2SAC-CLL-S/S-EL15	63475	51	HV1050M	75309	39	HV2400LL-PCST	63971	40
HV-1600-SAC-CLL-S/S-EL15	63244	51	HV-2400-2SAC-CLL-S/S-EL15	62697	45	HV1050M-PCST	73036	38	HV2400LL-PCST-S/S	64013	41
HV-1600-SAC-CM	62530	43	HV-2400-2SAC-CM	62577	43	HV1050M-PCST	63951	40	HV2400M-PCST	63969	40
HV-1600-SAC-CM-EL15	63221	49	HV-2400-2SAC-CM-EL15	63441	49	HV1050M-PCST-S/S	63993	41	HV2400M-PCST-S/S	64011	41
HV-1600-SAC-CM-S/S	62646	45	HV-2400-2SAC-CM-S/S	62693	45	HV1050M-S/S	75308	39	HV2600L-PCST	63973	40
HV-1600-SAC-CM-S/S-EL15	63242	51	HV-2400-2SAC-CM-S/S-EL15	62693	45	HV1050S	73056	38	HV2600L-PCST-S/S	64015	41
HV-1800-2SAC-CL	62569	43	HV-2400-2SAC-CM-S/S-EL15	63473	51	HV1050S-PCST	63950	40	HV2600LL-PCST	63974	40
HV-1800-2SAC-CL-EL15	63433	49	HV-2600-2SAC-CL-EL15	63445	49	HV1050S-PCST-S/S	63992	41	HV2600LL-PCST-S/S	64016	41
HV-1800-2SAC-CL-S/S	62685	45	HV-2600-2SAC-CL-S/S	62697	45	HV1050S-S/S	75307	39	HV2600M-PCST	63972	40
HV-1800-2SAC-CL-S/S-EL15	63465	51	HV-2600-2SAC-CL-S/S-EL15	63477	51	HV1050SS	73057	38	HV2600M-PCST-S/S	64014	41
HV-1800-2SAC-CLL	62570	43	HV-2600-2SAC-CLL	63446	49	HV1050SS-PCST	64045	40	HV3000L-PCST	63976	40
HV-1800-2SAC-CLL-EL15	63434	49	HV-2600-2SAC-CLL-EL15	62698	45	HV1050SS-PCST-S/S	63991	41	HV3000L-PCST-S/S	64018	41
HV-1800-2SAC-CLL-S/S	62686	45	HV-2600-2SAC-CLL-S/S	62698	45	HV1050SS-S/S	75306	39	HV3000LL-PCST	63977	40
HV-1800-2SAC-CLL-S/S-EL15	63466	51	HV-2600-2SAC-CLL-S/S-EL15	63478	51	HV1200L	73180	38	HV3000LL-PCST-S/S	64019	41
HV-1800-2SAC-CM	62568	43	HV-2600-2SAC-CM-EL15	63444	49	HV1200L-PCST	63956	40	HV3000M-PCST	63975	40
HV-1800-2SAC-CM-EL15	63432	49	HV-2600-2SAC-CM-S/S	62696	45	HV1200L-PCST-S/S	63998	41	HV3000M-PCST-S/S	64017	41
HV-1800-2SAC-CM-S/S	62684	45	HV-2600-2SAC-CM-S/S-EL15	63476	51	HV1200L-S/S	75313	39	HV450M	73019	38
HV-1800-2SAC-CM-S/S-EL15	63464	51	HV-2800-2SAC-CL-EL15	63448	49	HV1200M	73038	38	HV450M-PCST	63938	40
HV-1800-SAC-CL	62534	43	HV-2800-2SAC-CL-S/S	62700	45	HV1200M-PCST	63955	40	HV450M-PCST-S/S	63980	41
HV-1800-SAC-CL-EL15	63225	49	HV-2800-2SAC-CL-S/S-EL15	63480	51	HV1200M-PCST-S/S	63997	41	HV450M-S/S	75295	39
HV-1800-SAC-CL-S/S	62650	45	HV-2800-2SAC-CLL-EL15	63449	49	HV1200M-S/S	75312	39	HV450S	73028	38
HV-1800-SAC-CL-S/S-EL15	63246	51	HV-2800-2SAC-CLL-S/S	62701	45	HV1200S	73058	38	HV450S-PCST	63937	40
HV-1800-SAC-CLL	62535	43	HV-2800-2SAC-CLL-S/S-EL15	63481	51	HV1200S-PCST	63954	40	HV450S-PCST-S/S	63979	41
HV-1800-SAC-CLL-EL15	63226	49	HV-2800-2SAC-CLL-S/S-EL15	62701	45	HV1200S-PCST-S/S	63996	41	HV450S-S/S	75294	39
HV-1800-SAC-CLL-S/S	62651	45	HV-2800-2SAC-CM-EL15	63447	49	HV1200S-S/S	75311	39	HV450SS	73026	38
HV-1800-SAC-CLL-S/S-EL15	63247	51	HV-2800-2SAC-CM-S/S	62699	45	HV1200SS	73059	38	HV450SS-PCST	63936	40
HV-1800-SAC-CM	62533	43	HV-2800-2SAC-CM-S/S-EL15	63479	51	HV1200SS-PCST	63953	40	HV450SS-PCST-S/S	63978	41
HV-1800-SAC-CM-EL15	63224	49	HV-3000-2SAC-CL-EL15	63451	49	HV1200SS-PCST-S/S	63995	41	HV450SS-S/S	75293	39
HV-1800-SAC-CM-S/S	62649	45	HV-3000-2SAC-CL-S/S	62703	45	HV1200SS-S/S	75310	39	HV600M	73173	38
HV-1800-SAC-CM-S/S-EL15	63245	51	HV-3000-2SAC-CL-S/S-EL15	63483	51	HV1500L	73158	38	HV600M-PCST	63941	40
HV-2000-2SAC-CL	62572	43	HV-3000-2SAC-CLL-EL15	63452	49	HV1500L-PCST	63958	40	HV600M-PCST-S/S	63983	41
HV-2000-2SAC-CL-EL15	63436	49	HV-3000-2SAC-CLL-S/S	62704	45	HV1500L-PCST-S/S	64000	41	HV600M-S/S	75298	39
HV-2000-2SAC-CL-S/S	62688	45	HV-3000-2SAC-CLL-S/S-EL15	63484	51	HV1500L-S/S	75315	39	HV600S	73030	38
HV-2000-2SAC-CL-S/S-EL15	63468	51	HV-3000-2SAC-CLL-S/S-EL15	63484	51	HV1500LL	73215	38	HV600S-PCST	63940	40
HV-2000-2SAC-CLL	62573	43	HV-3000-2SAC-CM-EL15	63450	49	HV1500LL-PCST	63959	40	HV600S-PCST-S/S	63982	41
HV-2000-2SAC-CLL-EL15	63437	49	HV-3000-2SAC-CM-S/S	62702	45	HV1500LL-PCST-S/S	64001	41	HV600S-S/S	75297	39
HV-2000-2SAC-CLL-S/S	62689	45	HV-3000-2SAC-CM-S/S-EL15	63482	51	HV1500LL-S/S	75316	39	HV600SS	73045	38
HV-2000-2SAC-CLL-S/S-EL15	63469	51	HV-600-SAC-CL	62517	43	HV1500M	73177	38	HV600SS-PCST	63939	40
HV-2000-2SAC-CM	62571	43	HV-600-SAC-CL-EL15	63208	49	HV1500M-PCST	63957	40	HV600SS-PCST-S/S	63981	41
HV-2000-2SAC-CM-EL15	63435	49	HV-600-SAC-CL-S/S	62633	45	HV1500M-PCST-S/S	63999	41	HV600SS-S/S	75296	39
HV-2000-2SAC-CM-S/S	62687	45	HV-600-SAC-CL-S/S-EL15	63229	51	HV1500M-S/S	75314	39	HV750M	73174	38
HV-2000-2SAC-CM-S/S-EL15	63467	51	HV-600-SAC-CL-S/S-EL15	63229	51	HV1600L	73638	38	HV750M-PCST	63944	40
HV-2200-2SAC-CL	62575	43	HV-600-SAC-CM	62516	43	HV1600L-PCST	63961	40	HV750M-PCST-S/S	63986	41
HV-2200-2SAC-CL-EL15	63439	49	HV-600-SAC-CM-EL15	63207	49	HV1600L-PCST-S/S	64003	41	HV750M-S/S	75301	39
HV-2200-2SAC-CL-S/S	62691	45	HV-600-SAC-CM-S/S	62632	45	HV1600L-S/S	75318	39	HV750S	73032	38
HV-2200-2SAC-CL-S/S-EL15	63471	51	HV-600-SAC-CS	62515	43	HV1600LL	73639	38	HV750S-PCST	63943	40
HV-2200-2SAC-CLL	62576	43	HV-600-SAC-CS-EL15	63206	49	HV1600LL-PCST	63962	40	HV750S-PCST-S/S	63985	41
HV-2200-2SAC-CLL-EL15	63440	49	HV-600-SAC-CS-S/S	62631	45	HV1600LL-PCST-S/S	64004	41	HV750S-S/S	75300	39
HV-2200-2SAC-CLL-S/S	62692	45	HV-600-SAC-CS-S/S-EL15	63227	51	HV1600LL-S/S	75319	39	HV750SS	73053	38
HV-2200-2SAC-CLL-S/S-EL15	63472	51	HV-800-SAC-CL	62520	43	HV1600M	73637	38	HV750SS-PCST	63942	40
HV-2200-2SAC-CM	62574	43	HV-800-SAC-CL-EL15	63211	49	HV1600M-PCST	63960	40	HV750SS-PCST-S/S	63984	41
HV-2200-2SAC-CM-EL15	63438	49	HV-800-SAC-CL-S/S	62636	45	HV1600M-PCST-S/S	64002	41	HV750SS-S/S	75299	39
HV-2200-2SAC-CM-S/S	62690	45	HV-800-SAC-CL-S/S-EL15	63232	51	HV1600M-S/S	75317	39	HV900L	73178	38
			HV-800-SAC-CM	62519	43	HV1600M-PCST	63964	40	HV900L-PCST	63948	40
			HV-800-SAC-CM-EL15	63210	49	HV1600M-PCST-S/S	64006	41	HV900L-PCST-S/S	63990	41
			HV-800-SAC-CM-S/S	62635	45	HV1800LL-PCST	63965	40	HV900L-S/S	75305	39
						HV1800LL-PCST-S/S	64007	41	HV900M	73175	38
						HV1800M-PCST	63963	40	HV900M-PCST	63947	40
						HV1800M-PCST-S/S	64005	41	HV900M-PCST-S/S	63989	41



INDEX By Ordering Number

Ordering Number	Item Code	Page #	Ordering Number	Item Code	Page #	Ordering Number	Item Code	Page #	Ordering Number	Item Code	Page #
HV900M-S/S	75304	39	HXF1500M-S/S	75281	37	IB5	76927	131	LST-W-S/S	77125	13
HV900S	73034	38	HXF1600L	73444	36	IB5	76927	133	LST-W-S/S-2	77126	13
HV900S-PCST	63946	40	HXF1600L-S/S	75284	37	IB5	76927	135	LSTMPK	77366	12
HV900S-PCST-S/S	63988	41	HXF1600M	73443	36	IB5	76927	136	LSTMPK-S/S	78933	13
HV900S-S/S	75303	39	HXF1600M-S/S	75283	37	IB5	76927	137	LSTMPK2-S/S	78462	13
HV900SS	73055	38	HXF2-L	75982	36	IB5	76927	138	LSTPB-RK	77367	12
HV900SS-PCST	63945	40	HXF2-L	75982	37	IB5-1U	76966	139	LSTPB-RK	77367	13
HV900SS-PCST-S/S	63987	41	HXF2-M	75981	36	IBBK	76928	135	MAK	74918	159
HV900SS-S/S	75302	39	HXF2-M	75981	37	IBBK	76928	136	MAK-S/S	64926	159
HVC-S/S	73494	42	HXF2-S	75980	36	IBBK	76928	137	MAKHD	74919	159
HVHD1800L	74477	38	HXF2-S	75980	37	IBBK	76928	138	MAKHD	74919	159
HVHD1800L-S/S	A1595	39	HXF2-SS	75979	36	IBS-DH5	76934	137	MAPEK	76024	124
HVHD1800LL	74478	38	HXF2-SS	75979	37	IBS-DH5	76934	138	MBADB	79527	113
HVHD1800LL-S/S	A1596	39	HXF450M	74660	36	IBS-H4	76933	137	MBC-18	79494	111
HVHD1800M	74602	38	HXF450M-S/S	75267	37	IBS-L4	76929	135	MBC-24	79495	111
HVHD1800M-S/S	A1594	39	HXF450S	74659	36	IBS-L5	76930	135	MBC-30	79496	111
HVHD2100L	74540	38	HXF450S-S/S	75266	37	IBS-M1200	82397	133	MBC-36	79497	111
HVHD2100L-S/S	A1598	39	HXF600M	74662	36	IBS-M1500	82398	133	MBC-42	79498	111
HVHD2100LL	74541	38	HXF600M-S/S	75269	37	IBS-M4	76931	136	MBC-48	79499	111
HVHD2100LL-S/S	A1599	39	HXF600S	74661	36	IBS-M5	76932	136	MBC-54	79500	111
HVHD2100M	74539	38	HXF600S-S/S	75268	37	ID300x300 S/S			MBC-60	79501	111
HVHD2100M-S/S	A1597	39	HXF750M	74664	36	Inspection Door	62445	116	MBC-72	79502	111
HVHD2400L	74545	38	HXF750M-S/S	75271	37	ID400x400 S/S			MBC-84	79503	111
HVHD2400L-S/S	A1601	39	HXF750S	74663	36	Inspection Door	62446	116	MBCB	79526	113
HVHD2400LL-S/S	A1602	39	HXF750S-S/S	75270	37	ID500x500 S/S			MBCB	79525	113
HVHD2400M	74544	38	HXF8L	74691	36	Inspection Door	62447	116	MBCBL	79532	113
HVHD2400M-S/S	A1600	39	HXF8L	74691	37	ID600x600 S/S			MBCBL	79528	113
HVHD2600M-S/S	A2462	39	HXF8L-Blue	77521	36	Inspection Door	62448	116	MBCBM	79528	113
HVPT-S/S	73631	38	HXF8L-Blue	77521	37	IEA42-60D	76937	138	MBCDBK	79536	111
HVPT-S/S	73631	39	HXF8M	74690	36	IEA72-96D	76938	138	MBCDBK	79536	113
HVPT-S/S	73631	40	HXF8M	74690	37	IMK	76936	135	MBCEC	79534	113
HVPT-S/S	73631	41	HXF8M-Blue	77520	36	IMK	76936	136	MBCM-1	79529	113
HVPT-S/S	73631	42	HXF8M-Blue	77520	37	IMK	76936	137	MBCM-2	79530	113
HVPT-S/S	73631	45	HXF8S	74689	36	ISABK	76935	138	MBCMCK	79524	113
HVPT-S/S	73631	47	HXF8S	74689	37	ISABK-LMH	77529	135	MBCMCK	79533	113
HVPT-S/S	73631	48	HXF8S-Blue	77519	36	ISABK-LMH	77529	137	MBCTA	79531	113
HVPT-S/S	73631	51	HXF8S-Blue	77519	37	LS-BP	77114	12	MBDS-18	79504	113
HVPT-S/S	73631	53	HXF8SS	74307	36	LS-BP-S/S	77115	13	MBDS-24	79505	113
HVPT-S/S	73631	54	HXF8SS	74307	37	LS-SP	77365	12	MBDS-30	79506	113
HVT8-EL15-S/S	62254	53	HXF8SS-Blue	77518	36	LS-SS	77118	12	MBDS-36	79507	113
HVT8-EL15-S/S	63566	54	HXF8SS-Blue	77518	37	LS-SS	77118	13	MBDS-42	79508	113
HVT8-S/S	75419	39	HXF900L	74667	36	LS-SW	77117	12	MBDS-48	79509	113
HVT8-S/S	75419	41	HXF900L-S/S	75274	37	LS-SW-S/S	78850	13	MBDS-54	79510	113
HVT8-S/S	75419	42	HXF900M	74666	36	LSP12	77070	12	MBDS-60	79511	113
HVT8-S/S	75419	45	HXF900M-S/S	75273	37	LSP12-S/S	77079	13	MBDS-72	79512	113
HVT8-S/S	75419	47	HXF900S	74665	36	LSP18	77071	12	MBDS-84	79513	113
HVT8-S/S	75419	48	HXF900S-S/S	75272	37	LSP18-S/S	77080	13	MBRD-18	79514	111
HVT8-S/S	75419	51	HXFHD1800L	74682	36	LSP24	77072	12	MBRD-18	79514	113
HVT8-S/S	75419	53	HXFHD1800L-S/S	A1589	37	LSP24-S/S	77081	13	MBRD-24	79515	111
HVT8-S/S	75419	54	HXFHD1800M	74681	36	LSP30	77073	12	MBRD-24	79515	113
HW-BC	74100	123	HXFHD1800M-S/S	A1588	37	LSP30-S/S	77082	13	MBRD-30	79516	111
HW-IMPB	76939	139	HXFHD2100L	74684	36	LSP36	77074	12	MBRD-30	79516	113
HXF1050L	74670	36	HXFHD2100L-S/S	A1591	37	LSP36-S/S	77083	13	MBRD-36	79517	111
HXF1050L-S/S	75277	37	HXFHD2100M	74683	36	LSP42	77075	12	MBRD-36	79517	113
HXF1050M	74669	36	HXFHD2100M-S/S	A1590	37	LSP42-S/S	77084	13	MBRD-42	79518	111
HXF1050M-S/S	75276	37	HXFHD2400L	74686	36	LSP48	77076	12	MBRD-42	79518	113
HXF1050S	74668	36	HXFHD2400L-S/S	A1593	37	LSP48-S/S	77085	13	MBRD-48	79519	111
HXF1050S-S/S	75275	37	HXFHD2400M	74685	36	LSP54	77077	12	MBRD-48	79519	113
HXF1200L	74673	36	HXFHD2400M-S/S	A1592	37	LSP54-S/S	77086	13	MBRD-54	79520	111
HXF1200L-S/S	75280	37	IB4	76926	129	LSP60	77078	12	MBRD-54	79520	113
HXF1200M	74672	36	IB4	76926	131	LSP60-S/S	77087	13	MBRD-60	79521	111
HXF1200M-S/S	75279	37	IB4	76926	133	LST-B-S/S	77124	13	MBRD-60	79521	113
HXF1200S	74671	36	IB4	76926	135	LST-P	77121	12	MBRD-72	79522	111
HXF1200S-S/S	75278	37	IB4	76926	136	LST-S	77123	12	MBRD-72	79522	113
HXF1500L	74678	36	IB4	76926	137	LST-TAK	77120	12	MBRD-84	79523	111
HXF1500L-S/S	75282	37	IB4-1U	76965	139	LST-TAK	77120	13	MBRD-84	79523	113
HXF1500M	74677	36	IB5	76927	129	LST-W	77122	12	MCB	74925	159
									MCB	74925	159

INDEX By Ordering Number

Ordering Number	Item Code	Page #	Ordering Number	Item Code	Page #	Ordering Number	Item Code	Page #	Ordering Number	Item Code	Page #
MCBK	76025	159	MHCP-900S-S/S	61506	33	MHS-1200BTB	77525	70	MHS-2400V-2SAC-S/S	78548	91
MCBK	76025	159	MHCP-900S-S/S-FR	61626	33	MHS-1200BTB-S/S	77526	70	MHS-3000BTB-2SAC	78019	98
MCBKHD	76026	159	MHCP-BS	76394	32	MHS-1200BTB-SAC	78011	98	MHS-3000BTB-2SAC-S/S	78328	98
MCBKHD	76026	159	MHCP-CH	76393	32	MHS-1200BTB-SAC-S/S	78320	98	MHS-3000V-2SAC	78174	91
MCRK	74923	159	MHCP-S/S-CBK	61550	35	MHS-1200FPV	77793	72	MHS-3000V-2SAC-S/S	78549	91
MCRK	74923	159	MHCP-S/S-CEB	61549	35	MHS-1200FPV-S/S	77803	72	MHS-600-MST	64020	67
MCS	74930	159	MHCP-S/S-CH	61548	35	MHS-1200V-SAC	78166	91	MHS-600-MST-S/S	64030	67
MCS	74930	159	MHCP-S/S-CK1050	61538	35	MHS-1200V-SAC-S/S	78541	91	MHS-600BTB	77481	70
MCSHD	74931	159	MHCP-S/S-CK1200	61539	35	MHS-1350-MST	64025	67	MHS-600BTB-S/S	77490	70
MCSHD	74931	159	MHCP-S/S-CK1350	61540	35	MHS-1350-MST-S/S	64035	67	MHS-600BTB-SAC	78007	98
MCSK	74927	159	MHCP-S/S-CK1500	61541	35	MHS-1350BTB	77485	70	MHS-600BTB-SAC-S/S	78316	98
MCSK	74927	159	MHCP-S/S-CK1650	61542	35	MHS-1350BTB-S/S	77494	70	MHS-600FPV	77789	72
MCSKHD	74928	159	MHCP-S/S-CK1800	61543	35	MHS-1350BTB-SAC	78012	98	MHS-600FPV-S/S	77799	72
MCSKHD	74928	159	MHCP-S/S-CK2100	61544	35	MHS-1350BTB-SAC-S/S	78321	98	MHS-600V-SAC	78162	91
MESBK-PS	82364	107	MHCP-S/S-CK600	61535	35	MHS-1350FPV	77794	72	MHS-600V-SAC-S/S	78537	91
MESBK-PS	82364	108	MHCP-S/S-CK750	61536	35	MHS-1350FPV-S/S	77804	72	MHS-750-MST	64021	67
MESPBL	87895	107	MHCP-S/S-CK900	61537	35	MHS-1350V-SAC	78167	91	MHS-750-MST-S/S	64031	67
MESPBL-SS	82892	108	MHCP-S/S-CLP	61545	35	MHS-1350V-SAC-S/S	78542	91	MHS-750BTB	77482	70
MESPKR	81896	107	MHCP-S/S-CP 1050	61527	35	MHS-1500-MST	64026	67	MHS-750BTB-S/S	77491	70
MESPKR-SS	82894	108	MHCP-S/S-CP 1200	61528	35	MHS-1500-MST-S/S	64036	67	MHS-750BTB-SAC	78008	98
MFASK	75531	159	MHCP-S/S-CP 1350	61529	35	MHS-1500BTB	77486	70	MHS-750BTB-SAC-S/S	78317	98
MFASK	75531	159	MHCP-S/S-CP 1500	61530	35	MHS-1500BTB-2SAC	78015	98	MHS-750FPV	77790	72
MHCP-1050S-S/S	61507	33	MHCP-S/S-CP 1650	61531	35	MHS-1500BTB-2SAC-S/S	78324	98	MHS-750FPV-S/S	77800	72
MHCP-1050S-S/S-FR	61627	33	MHCP-S/S-CP 1800	61532	35	MHS-1500BTB-S/S	77495	70	MHS-750V-SAC	78163	91
MHCP-1200S-S/S	61508	33	MHCP-S/S-CP 2100	61533	35	MHS-1500BTB-SAC	78013	98	MHS-750V-SAC-S/S	78538	91
MHCP-1200S-S/S-FR	61628	33	MHCP-S/S-CP 600	61634	35	MHS-1500BTB-SAC-S/S	78322	98	MHS-900-MST	64022	67
MHCP-1350S-S/S	61509	33	MHCP-S/S-CP 750	61525	35	MHS-1500FPV	77795	72	MHS-900-MST-S/S	64032	67
MHCP-1350S-S/S-FR	61629	33	MHCP-S/S-CP 900	61526	35	MHS-1500FPV-S/S	77805	72	MHS-900BTB	77483	70
MHCP-1500S-S/S	61510	33	MHCP-S/S-PSTS	61547	35	MHS-1500V-2SAC	78170	91	MHS-900BTB-S/S	77492	70
MHCP-1500S-S/S-FR	61630	33	MHCP-S/S-PSTW	61546	35	MHS-1500V-2SAC-S/S	78545	91	MHS-900BTB-SAC	78009	98
MHCP-1650S-S/S	61511	33	MHCP-SS/EP	61534	35	MHS-1500V-SAC	78168	91	MHS-900BTB-SAC-S/S	78318	98
MHCP-1650S-S/S-FR	61631	33	MHP-CP1050	75964	32	MHS-1500V-SAC-S/S	78543	91	MHS-900FPV	77791	72
MHCP-1800S-S/S	61512	33	MHP-CP1200	75965	32	MHS-1800-MST	64027	67	MHS-900FPV-S/S	77801	72
MHCP-1800S-S/S-FR	61632	33	MHP-CP1400	75966	32	MHS-1800-MST-S/S	64037	67	MHS-900V-SAC	78164	91
MHCP-2100S-S/S	61513	33	MHP-CP1500	75967	32	MHS-1800BTB	77487	70	MHS-900V-SAC-S/S	78539	91
MHCP-2100S-S/S-FR	61633	33	MHP-CP1800	75968	32	MHS-1800BTB-2SAC	78016	98	MHS-CARK-V24/600	77937	92
MHCP-24A	75937	30	MHP-CP2100	76811	32	MHS-1800BTB-2SAC-S/S	78325	98	MHS-CARK-V24/600	77937	99
MHCP-24S	75929	30	MHP-CP600	75961	32	MHS-1800BTB-S/S	77496	70	MHS-CARK-V24/600-S/S MVECKS/S	82841	92
MHCP-2BC24	76638	32	MHP-CP750	75962	32	MHS-1800BTB-SAC	78014	98	MHS-CARK-V24/600-S/S MVECKS/S	82841	99
MHCP-2BC30	76639	32	MHP-CP900	75963	32	MHS-1800BTB-SAC-S/S	78323	98	MHS-CARK-V30/750	77938	92
MHCP-2BC36	76640	32	MHP-EP	76392	25	MHS-1800FPV	77796	72	MHS-CARK-V30/750	77938	99
MHCP-2BC42	76641	32	MHP-EP	76392	32	MHS-1800FPV-S/S	77806	72	MHS-CARK-V30/750-S/S MVECKS/S	82842	92
MHCP-2BC48	76642	32	MHP-EP	76392	48	MHS-1800V-2SAC	78171	91	MHS-CARK-V30/750-S/S MVECKS/S	82842	99
MHCP-2BC54	76643	32	MHP-EP	76392	54	MHS-1800V-2SAC-S/S	78546	91	MHS-CARK-V36/900	77939	92
MHCP-2BC60	76644	32	MHP-EP	76392	79	MHS-1800V-SAC	78169	91	MHS-CARK-V36/900	77939	99
MHCP-2BC72	76645	32	MHP-EP	76392	86	MHS-1800V-SAC-S/S	78544	91	MHS-CARK-V36/900-S/S MVECKS/S	82843	92
MHCP-2BC84	76812	32	MHP-EP	76392	93	MHS-1950BTB-2SAC-S/S	78649	98	MHS-CARK-V36/900-S/S MVECKS/S	82843	99
MHCP-30A	75938	30	MHP-EP	76392	100	MHS-1950V-2SAC-S/S	78649	91	MHS-CARK-V42/1050	77940	92
MHCP-30S	75930	30	MHP-EP-S/S	77599	27	MHS-2100-MST	64028	67	MHS-CARK-V42/1050	77940	99
MHCP-36A	75939	30	MHP-EP-S/S	77599	48	MHS-2100-MST-S/S	64038	67	MHS-CARK-V42/1050-S/S MVECKS/S	82844	92
MHCP-36S	75931	30	MHP-EP-S/S	77599	54	MHS-2100BTB	77488	70	MHS-CARK-V42/1050-S/S MVECKS/S	82844	99
MHCP-42A	75940	30	MHP-EP-S/S	77599	81	MHS-2100BTB-2SAC	78017	98	MHS-CARK-V48/1200	77941	99
MHCP-42S	75932	30	MHP-EP-S/S	77599	88	MHS-2100BTB-2SAC-S/S	78326	98	MHS-CARK-V48/1200-S/S MVECKS/S	82845	92
MHCP-48A	75941	30	MHP-EP-S/S	77599	95	MHS-2100BTB-S/S	77497	70	MHS-CARK-V48/1200-S/S MVECKS/S	82845	99
MHCP-48S	75933	30	MHP-EP-S/S	77599	101	MHS-2100FPV	77797	72	MHS-CARK-V54/1350	77942	92
MHCP-54A	75942	30	MHS-1050-MST	64023	67	MHS-2100FPV-S/S	77807	72	MHS-CARK-V54/1350	77942	99
MHCP-54S	75934	30	MHS-1050-MST-S/S	64033	67	MHS-2100V-2SAC	78172	91	MHS-CARK-V54/1350-S/S MVECKS/S	82846	92
MHCP-600S-S/S	61504	33	MHS-1050BTB	77484	70	MHS-2100V-2SAC-S/S	78547	91			
MHCP-600S-S/S-FR	61624	33	MHS-1050BTB-S/S	77493	70	MHS-2400-MST	64029	67			
MHCP-60A	75943	30	MHS-1050BTB-SAC	78010	98	MHS-2400-MST-S/S	64039	67			
MHCP-60S	75935	30	MHS-1050BTB-SAC-S/S	78319	98	MHS-2400BTB	77489	70			
MHCP-72A	75944	30	MHS-1050FPV	77792	72	MHS-2400BTB-2SAC	78018	98			
MHCP-72S	75936	30	MHS-1050FPV-S/S	77802	72	MHS-2400BTB-2SAC-S/S	78327	98			
MHCP-750S-S/S	61505	33	MHS-1050V-SAC	78165	91	MHS-2400BTB-S/S	77498	70			
MHCP-750S-S/S-FR	61625	33	MHS-1050V-SAC-S/S	78540	91	MHS-2400FPV	77798	72			
MHCP-84A	76801	30	MHS-1200-MST	64024	67	MHS-2400FPV-S/S	77808	72			
MHCP-84S	76800	30	MHS-1200-MST-S/S	64034	67	MHS-2400V-2SAC	78173	91			



INDEX By Ordering Number

Ordering Number	Item Code	Page #	Ordering Number	Item Code	Page #	Ordering Number	Item Code	Page #	Ordering Number	Item Code	Page #
MHS-CARK-V54/1350-S/S MVECKS/S	82846	99	MHS-P1800*	77505	73	MMPCP48	76462	25	NI6D3T-54-19-A45	26189	129
MHS-CARK-V60/1500	77943	92	MHS-P1800S/S	77514	68	MMPCP48-S/S	77594	27	NI6D3T-60-21-A45	26190	129
MHS-CARK-V60/1500	77943	99	MHS-P1800S/S*	77514	71	MMPCP54	76463	25	NI6D3T-72-25-A45	26191	129
MHS-CARK-V60/1500-S/S MVECKS/S	82847	92	MHS-P1800S/S*	77514	73	MMPCP54-S/S	77595	27	NS6DV-18-9.625-A45	26714	154
MHS-CARK-V60/1500-S/S MVECKS/S	82847	99	MHS-P2100	77506	68	MMPCP60	76464	25	NS6DV-18-9.625-A45	26714	156
MHS-CARK-V72/1800	77944	92	MHS-P2100*	77506	71	MMPCP60-S/S	77596	27	NS6DV-24-12.625-A45	26715	154
MHS-CARK-V72/1800	77944	99	MHS-P2100*	77506	73	MMPCP72	76465	25	NS6DV-24-12.625-A45	26715	156
MHS-CARK-V72/1800-S/S MVECKS/S	82848	92	MHS-P2100S/S	77515	68	MMPCP72-S/S	77597	27	NS6DV-30-15.625-A45	26716	154
MHS-CARK-V72/1800-S/S MVECKS/S	82848	99	MHS-P2100S/S*	77515	71	MMPCP84	76808	25	NS6DV-30-15.625-A45	26716	156
MHS-CARK2-V120/3000	77954	92	MHS-P2100S/S*	77515	73	MMPCP84-S/S	77598	27	NS6DV-36-18.625-A45	26717	154
MHS-CARK2-V120/3000	77954	99	MHS-P2400	77507	68	MMPK	76537	124	NS6DV-36-18.625-A45	26717	156
MHS-CARK2-V120/3000-S/S MV2CKSS	82853	92	MHS-P2400*	77507	71	MORK	74921	159	NS6DV-42-21.625-A45	26718	154
MHS-CARK2-V120/3000-S/S MV2CKSS	82853	99	MHS-P2400*	77507	73	MORK	74921	159	NS6DV-42-21.625-A45	26718	156
MHS-CARK2-V60/1500	77950	92	MHS-P2400S/S	77516	68	MPSTA-S/S	82289	108	NS6DV-48-24.625-A45	26719	154
MHS-CARK2-V60/1500	77950	99	MHS-P2400S/S*	77516	71	MQMTSBK-SS	82895	108	NS6DV-48-24.625-A45	26719	156
MHS-CARK2-V60/1500-S/S MV2CKSS	82849	92	MHS-P2400S/S*	77516	73	MR-1050PG	A2840	120	NS6DV-54-27.625-A45	26720	154
MHS-CARK2-V60/1500-S/S MV2CKSS	82849	99	MHS-P600	77499	68	MR-1200PG	A2841	120	NS6DV-54-27.625-A45	26720	156
MHS-CARK2-V72/1800	77951	92	MHS-P600*	77499	71	MR-1500PG	A2829	120	NS6DV-60-30.625-A45	26721	154
MHS-CARK2-V72/1800	77951	99	MHS-P600*	77499	73	MR-1600PG	A2830	120	NS6DV-60-30.625-A45	26721	156
MHS-CARK2-V72/1800-S/S MV2CKSS	82850	92	MHS-P600S/S	77508	68	MR-1800PG	A2831	120	NS6DV-72-36.625-A45	26722	154
MHS-CARK2-V72/1800-S/S MV2CKSS	82850	99	MHS-P600S/S*	77508	71	MR-2100PG	A2832	120	NS6DV-72-36.625-A45	26722	156
MHS-CARK2-V84/2100	77952	92	MHS-P600S/S*	77508	73	MR-2400PG	A2833	120	NS7DV-48-24.625-A105	26723	154
MHS-CARK2-V84/2100	77952	99	MHS-P750	77500	68	MR-2600PG	A2834	120	NS7DV-54-27.625-A105	26724	154
MHS-CARK2-V84/2100-S/S MV2CKSS	82851	92	MHS-P750*	77500	71	MR-3000PG	A2835	120	NS7DV-60-30.625-A105	26725	154
MHS-CARK2-V84/2100-S/S MV2CKSS	82851	99	MHS-P750*	77500	73	MR-450PG	A2836	120	NS7DV-72-36.625-A105	26726	154
MHS-CARK2-V96/2400	77953	92	MHS-P750S/S	77509	68	MR-600PG	A2837	120	NS7DV-84-42.625-A105	26727	154
MHS-CARK2-V96/2400	77953	99	MHS-P750S/S*	77509	71	MR-750PG	A2838	120	NS7DV-96-48.625-A105	26728	154
MHS-CARK2-V96/2400-S/S MV2CKSS	82852	92	MHS-P750S/S*	77509	73	MR-900PG	A2839	120	NS7EV-48-24.625-A105	26723	156
MHS-CARK2-V96/2400-S/S MV2CKSS	82852	99	MHS-P900	77501	68	MSPBPK-S/S	77583	18	NS7EV-54-27.625-A105	26724	156
MHS-P1050	77502	68	MHS-P900*	77501	71	MSPMPK	75811	25	NS7EV-60-30.625-A105	26725	156
MHS-P1050*	77502	71	MHS-P900*	77501	73	MSPMPK-S/S	77582	27	NS7EV-72-36.625-A105	26726	156
MHS-P1050*	77502	73	MHS-P900S/S	77510	68	MSR	74914	157	NS7EV-84-42.625-A105	26727	156
MHS-P1050S/S	77511	68	MHS-P900S/S*	77510	71	MSR	74914	159	NS7EV-96-48.625-A105	26728	156
MHS-P1050S/S*	77511	71	MHS-P900S/S*	77510	73	MSR-S/S	C7673	158	OIBBK	76950	139
MHS-P1050S/S*	77511	73	MMBK	75830	124	MSR-S/S	64924	159	P-CARK-V24/600	78080	78
MHS-P1200	77527	68	MMKU	77324	107	MST-MBL	79436	69	P-CARK-V24/600-S/S PVECKS/S	82815	78
MHS-P1200*	77527	71	MMKU-SS	77357	108	MST-MBR	79437	69	P-CARK-V30/750	78081	78
MHS-P1200*	77527	73	MMKUHD	77327	107	MSTAM	79435	68	P-CARK-V30/750-S/S PVECKS/S	82816	78
MHS-P1200S/S	77528	68	MMKUHD-SS	77358	108	MSTAM-S/S	64931	68	P-CARK-V36/900	78082	78
MHS-P1200S/S*	77528	71	MMP-624	76450	23	MSTBK	79440	68	P-CARK-V36/900-S/S PVECKS/S	82817	78
MHS-P1200S/S*	77528	73	MMP-624-S/S	77424	24	MSTBK	79440	68	P-CARK-V42/1050	78083	78
MHS-P1350	77503	68	MMP-630	76451	23	MSTDB	79434	69	P-CARK-V42/1050-S/S PVECKS/S	82818	78
MHS-P1350*	77503	71	MMP-630-S/S	77425	24	MSTHD-B	79433	68	P-CARK-V48/1200	78084	78
MHS-P1350*	77503	73	MMP-636	76452	23	MSTHD-G	63020	68	P-CARK-V48/1200-S/S PVECKS/S	82819	78
MHS-P1350S/S	77512	68	MMP-636-S/S	77426	24	MSTHD-S	79432	68	P-CARK-V54/1350	78085	78
MHS-P1350S/S*	77512	71	MMP-642	76453	23	MSTHD-SS-B	90183	68	P-CARK-V54/1350-S/S PVECKS/S	82820	78
MHS-P1350S/S*	77512	73	MMP-642-S/S	77427	24	MSTHD-SS-G	90184	68	P-CARK-V60/1500	78086	78
MHS-P1500	77504	68	MMP-648	76454	23	MSTHD-SS-S	90182	68	P-CARK-V60/1500-S/S PVECKS/S	82821	78
MHS-P1500*	77504	71	MMP-648-S/S	77428	24	MSTHD-SS-W	90181	68	P-CARK-V72/1800	78087	78
MHS-P1500*	77504	73	MMP-654	76455	23	MSTHD-W	79431	68	P-CARK-V72/1800-S/S PVECKS/S	82822	78
MHS-P1500S/S	77513	68	MMP-654-S/S	77429	24	MSTLP	64930	68	P-CARK2-V120/3000	78097	78
MHS-P1500S/S*	77513	71	MMP-660	76456	23	MUPSBK	64930	68	P-CARK2-V120/3000-S/S PV2ECKSS	82827	78
MHS-P1500S/S*	77513	73	MMP-660-S/S	77430	24	MUPSBK-SS	82896	107	P-CARK2-V60/1500	78093	78
MHS-P1800	77505	68	MMP-672	76457	23	N6D3T-24-9-A45	82893	108	P-CARK2-V60/1500-S/S PV2ECKSS	82823	78
MHS-P1800*	77505	71	MMP-672-S/S	77431	24	N6D3T-24-9-A45	26107	127	P-CARK2-V72/1800	78094	78
			MMP-684	76798	23	N6D3T-30-11-A45	26108	127	P-CARK2-V72/1800-S/S PV2ECKSS	82824	78
			MMP-684-S/S	77432	24	N6D3T-36-13-A45	26109	127	P-CARK2-V78/1950-S/S PV2ECKSS	82876	78
			MMPBPK	76466	25	N6D3T-36-13-A45	26110	127	P-CARK2-V84/2100	78095	78
			MMPBPK-S/S	77600	27	N6D3T-42-15-A45	26111	127			
			MMPCP24	76458	25	N6D3T-42-15-A45	26112	127			
			MMPCP24-S/S	77590	27	N6D3T-48-17-A45	26113	127			
			MMPCP30	76459	25	N6D3T-48-17-A45	26114	127			
			MMPCP30-S/S	77591	27	N6D3T-54-19-A45	26115	127			
			MMPCP36	76460	25	N6D3T-60-21-A45	26116	127			
			MMPCP36-S/S	77592	27	N6D3T-72-25-A45	26117	129			
			MMPCP42	76461	25	NI6D3T-24-9-A45	26184	129			
			MMPCP42-S/S	77593	27	NI6D3T-24-9-A45	26185	129			
						NI6D3T-30-11-A45	26185	129			
						NI6D3T-36-13-A45	26186	129			
						NI6D3T-42-15-A45	26187	129			
						NI6D3T-48-17-A45	26188	129			

INDEX By Ordering Number

Ordering Number	Item Code	Page #	Ordering Number	Item Code	Page #	Ordering Number	Item Code	Page #	Ordering Number	Item Code	Page #
P-CARK2-V84/2100-S/S PV2ECKSS	82825	78	PMBL (left)	75516	71	PS1800	73537	119	PTM-1600-1		157
P-CARK2-V96/2400	78096	78	PMBL (right)	75519	64	PS1800PL*	74049	119	PTM-1600-1-S/S		158
P-CARK2-V96/2400-S/S PV2ECKSS	82826	78	PMBL (right)	75519	66	PS2000	73539	119	PTM-1600-2		157
P/RMK	73025	61	PMBL (right)	75519	71	PS2000 PL*	74050	119	PTM-1600-2-S/S		158
PAB	75513	61	PMBL-S/S	75518	69	PS600	73014	119	PTM-1600-3		157
PAB	75513	62	PMBL-S/S	75518	74	PS600PL*	73582	119	PTM-1600-3-S/S		158
PAB	75513	64	PMBL-S/S	75518	82	PS750	73541	119	PTM-1800-1		157
PAB	75513	66	PMBL-S/S	75518	89	PS750PL*	73583	119	PTM-1800-1-S/S		158
PAB	75513	71	PMBL-S/S	75518	94	PS900	73542	119	PTM-1800-2		157
PAB	75513	80	PMBL-S/S	75518	102	PS900PL*	73584	119	PTM-1800-2-S/S		158
PAB	75513	87	PMBL-S/S (left)	75518	64	PSA150	73156	64	PTM-1800-3		157
PAB	75513	100	PMBL-S/S (left)	75518	66	PSA150	73156	66	PTM-1800-3-S/S		158
PAB	75513	114	PMBL-S/S (left)	75518	71	PSA150	73156	80	PTM-2000-1		157
PAB-S/S	75515	64	PMBL-S/S (right)	75521	64	PSA150 (V-Tip)	73156	77	PTM-2000-1-S/S		158
PAB-S/S	75515	66	PMBL-S/S (right)	75521	66	PSN11010	74053	119	PTM-2000-2		157
PAB-S/S	75515	71	PMBL-S/S (right)	75521	71	PSR-L	74560	147	PTM-2000-2-S/S		158
PAB-S/S	75515	82	PMBL-S/S (right)	75521	71	PSR-L-F	62352	147	PTM-2000-3		157
PAB-S/S	75515	89	PMBR	75519	80	PSR-M	74559	147	PTM-2000-3-S/S		158
PAB-S/S	75515	102	PMBR	75519	87	PSR-M-F	62351	147	PTM-2400-1		157
PACB100	79656	69	PMBR	75519	114	PSR-S	74558	147	PTM-2400-1-S/S		158
PACB100	79656	74	PMBR (right)	75519	61	PSR-S-F	62350	147	PTM-2400-2		157
PACB100	79656	94	PMBR (right)	75519	62	PSR-XL	74561	147	PTM-2400-2-S/S		158
PACB60	78683	69	PMBR-S/S	75521	69	PSR-XL-F	62353	147	PTM-2400-3		157
PACB60	78683	74	PMBR-S/S	75521	74	PSSS	74773	64	PTM-2400-3-S/S		158
PACB60	78683	94	PMBR-S/S	75521	82	PSSS-H	73222	119	PTM-2600-1		157
PAT1	78684	29	PMBR-S/S	75521	89	PSSS-N	73221	119	PTM-2600-1-S/S		158
PAT2	78685	29	PMBR-S/S	75521	94	PST-S	75894	32	PTM-2600-2		157
PATHK	78794	29	PMBR-S/S	75521	102	PST-W	75893	32	PTM-2600-2-S/S		158
PATLK	78791	29	PMR-CHB-L60	61073	120	PSTA	75896	25	PTM-2600-3		157
PBC-1	61356	162	PMR-CHB-L73	61075	120	PSTA	75896	32	PTM-2600-3-S/S		158
PBC-2	61357	162	PMR-CHB-R60	61074	120	PSTA-S/S	77442	27	PTM-3000-1		157
PBC-FR	61358	162	PMR-CHB-R73	61076	120	PSTS-S	75899	32	PTM-3000-1-S/S		158
PCAP-24/600	77913	80	PMSMK	74916	159	PSTS-S	75899	35	PTM-3000-2		157
PCAP-24/600-S/S	78355	82	PMSMK-S/S	64925	159	PSTS-S	75899	55	PTM-3000-2-S/S		158
PCAP-30/750	77914	80	PP1050	73011	64	PSTS-S-S/S	79056	55	PTM-3000-3		157
PCAP-30/750-S/S	78356	82	PP1050-S/S	75386	64	PSTS-W	75898	25	PTM-3000-3-S/S		158
PCAP-36/900	77915	80	PP1200	73013	64	PSTS-W	75898	32	PTM-750-1		157
PCAP-36/900-S/S	78357	82	PP1200-S/S	75387	64	PSTS-W	75898	35	PTM-750-1-S/S		158
PCAP-42/1050	77916	80	PP1400	73015	64	PSTS-W	75898	107	PTM-750-2		157
PCAP-42/1050-S/S	78358	82	PP1400-S/S	75388	64	PSVA	73434	119	PTM-750-2-S/S		158
PCAP-48/1200	77917	80	PP1500	73016	64	PTEZ-1050	90269	149	PTM-750-3		157
PCAP-48/1200-S/S	78359	82	PP1500-S/S	75389	64	PTEZ-1200	90270	149	PTM-750-3-S/S		158
PCAP-54/1350	77918	80	PP450	73003	64	PTEZ-450	90265	149	PTM-900-1		157
PCAP-54/1350-S/S	78360	82	PP450-S/S	75382	64	PTEZ-600	90266	149	PTM-900-1-S/S		158
PCAP-60/1500	77919	80	PP600	73005	64	PTEZ-750	90267	149	PTM-900-2		157
PCAP-60/1500-S/S	78361	82	PP600-S/S	75383	64	PTEZ-900	90268	149	PTM-900-2-S/S		158
PCAP-72/1800	77920	80	PP750	73007	64	PTM-1050-1		157	PTM-900-3		157
PCAP-72/1800-S/S	78362	82	PP750-S/S	75384	64	PTM-1050-1-S/S		158	PTM-900-3-S/S		158
PCB	75507	61	PP900	73009	64	PTM-1050-2		157	PTMSR	A0235	157
PFC-P-S/S	79289	64	PP900-S/S	75385	64	PTM-1050-2-S/S		158	PTP-EBKR	79484	156
PHA	73626	64	PPHD1800	74597	64	PTM-1050-3		157	PTP-HDEBKR	79486	156
PHA	73626	80	PPHD1800-S/S	A1781	64	PTM-1050-3-S/S		158	PTP-HDRBK	79492	156
PHDCB	75510	62	PPHD2000	74556	64	PTM-1200-1		157	PTP-HDRPA	79478	156
PHSC-S/S	73433	64	PPHD2000 -S/S	A2120	64	PTM-1200-1-S/S		158	PTP-LS	79488	156
PHSC-S/S	73433	82	PPHD2100	A2803	64	PTM-1200-2		157	PTP-RMB	79490	156
PHSC-S/S	73433	119	PPHD2100 -S/S	A1613	64	PTM-1200-2-S/S		158	PTP-RPA	79476	156
PIHMK	73160	62	PPHD2400	74557	64	PTM-1200-3		157	PTP-RRB	79491	156
PMB	75895	32	PPHD2400 -S/S	A1775	64	PTM-1200-3-S/S		158	PTP18R	79267	154
PMBL	75516	80	PPS6	73024	64	PTM-1350-1		157	PTP24R	79268	154
PMBL	75516	87	PS1050	73543	119	PTM-1350-1-S/S		158	PTP30R	79269	154
PMBL	75516	100	PS1050PL*	73585	119	PTM-1350-2		157	PTP36R	79270	154
PMBL	75516	114	PS1200	73544	119	PTM-1350-2-S/S		158	PTP42R	79271	154
PMBL (left)	75516	61	PS1200PL*	73586	119	PTM-1350-3		157	PTP48R	79272	154
PMBL (left)	75516	62	PS1400	73546	119	PTM-1350-3-S/S		158	PTP54R	79273	154
PMBL (left)	75516	64	PS1400PL*	73587	119	PTM-1500-1		157	PTP60R	79274	154
PMBL (left)	75516	66	PS1500	73545	119	PTM-1500-2		157	PTP72R	79275	154
			PS1500PL*	73588	119	PTM-1500-3		157	PTPHD48R	79276	154

INDEX By Ordering Number

Ordering Number	Item Code	Page #	Ordering Number	Item Code	Page #	Ordering Number	Item Code	Page #	Ordering Number	Item Code	Page #
PTPHD54R	79277	154	PV2400-2SAC	78031	77	R-CARK-V24/600	78106	85	RCAP-60/1500-S/S	78369	89
PTPHD60R	79278	154	PV2400-2SAC-S/S	78340	77	R-CARK-V24/600-S/S RVECKSS	82828	85	RCAP-72/1800	77928	87
PTPHD72R	79279	154	PV3000-2SAC	78032	77	R-CARK-V30/750	78107	85	RCAP-72/1800-S/S	78370	89
PTPHD84R	79280	154	PV3000-2SAC-S/S	78341	77	R-CARK-V30/750-S/S RVECKSS	82829	85	RIBBK	81250	127
PTPHD96R	79281	154	PV450	73435	63	R-CARK-V36/900	78108	85	RIBBK	81250	129
PTPK	75897	32	PV450-S/S	75323	63	R-CARK-V42/1050	78109	85	RIBBK	81250	131
PTPK-MT	82343	107	PV600	73004	63	R-CARK-V42/1050-S/S RVECKSS	82831	85	RIBBK	81250	133
PTPK-MT-S/S	82342	108	PV600-S/S	75324	63	R-CARK-V48/1200	78110	85	RMC-FS	76558	161
PTPLB	79470	156	PV600-SAC	78020	77	R-CARK-V48/1200-S/S RVECKSS	82832	85	RP1050	74608	66
PTPLB-HD	79473	156	PV600-SAC-S/S	78329	77	R-CARK-V54/1350	78111	85	RP1050-S/S	75404	66
PTS-18R	77664	151	PV750	73006	63	R-CARK-V54/1350-S/S RVECKSS	82833	85	RP1200	74609	66
PTS-24R	77665	151	PV750-S/S	75325	63	R-CARK-V60/1500	78112	85	RP1200-S/S	75405	66
PTS-30R	77666	151	PV750-SAC	78021	77	R-CARK-V60/1500-S/S RVECKSS	82834	85	RP1400	74610	66
PTS-36R	77667	151	PV750-SAC-S/S	78330	77	R-CARK-V72/1800	78113	85	RP1400-S/S	75406	66
PTS-42R	77668	151	PV900	73008	63	R-CARK-V72/1800-S/S RVECKSS	82835	85	RP1500	74611	66
PTS-48R	77669	151	PV900-S/S	75326	63	R-CARK-V72/1800-S/S RVECKSS	82836	85	RP1500-S/S	75407	66
PTS-54R	77670	151	PV900-SAC	78022	77	R-CARK2-V120/3000	78123	85	RP450	74604	66
PTS-60R	77671	151	PV900-SAC-S/S	78331	77	R-CARK2-V120/3000-S/S RV2ECKSS	82840	85	RP450-S/S	75400	66
PTS-72R	77672	151	PVHD1800	74598	63	R-CARK2-V60/1500	78119	85	RP600	74605	66
PTS-ABK	77693	152	PVHD1800-S/S	A1603	63	R-CARK2-V60/1500-S/S RV2ECKSS	82836	85	RP600-S/S	75401	66
PTS-EBK	77702	152	PVHD2000	75452	63	R-CARK2-V72/1800	78120	85	RP750	74606	66
PTS-HDSR	77692	152	PVHD2000-S/S	A2046	63	R-CARK2-V72/1800-S/S RV2ECKSS	82837	85	RP750-S/S	75402	66
PTS-HIBK	77697	152	PVHD2100	74553	63	R-CARK2-V84/2100	78121	85	RP900	74607	66
PTS-IBK	77696	152	PVHD2100-S/S	A1604	63	R-CARK2-V84/2100-S/S RV2ECKSS	82838	85	RP900-S/S	75403	66
PTS-LHSAA	77756	152	PVHD2400	74555	63	R-CARK2-V96/2400	78122	85	RPHD1800	74613	66
PTS-MBK	77700	152	PVHD2400-S/S	A1605	63	R-CARK2-V96/2400-S/S RV2ECKSS	82839	85	RPHD1800-S/S	A1575	66
PTS-MBKUG	77701	152	PVT6-S/S	75420	64	RBPCP	73162	148	RPHD2000	74614	66
PTS-PA	77699	152	PVT6-S/S	75420	66	RBPFK-L	73948	148	RPHD2000-S/S	61270	66
PTS-PS	77698	152	PVT6-S/S	75420	82	RBPFK-M	73947	148	RPHD2100	A2527	66
PTS-RHSAA	77755	152	PVT6-S/S	75420	119	RBPFK-S	73946	148	RPHD2100-S/S	A1629	66
PTS-RR21	77680	151	QMT-G	76483	25	RBPFK-XL	73949	148	RPHD2400	74615	66
PTS-RR27	77681	151	QMT-G	76484	107	RBPMBK	74327	148	RPHD2400-S/S	61271	66
PTS-RR33	77682	151	QMT-G-S/S	77586	27	RBPRET	A1622	148	RSA	76249	66
PTS-RR39	77683	151	QMT-P	76074	25	RBPRET	73163	152	RSA	76249	87
PTS-RR45	77684	151	QMT-P-S/S	77584	27	RBPSR-L	74564	148	RSA150	73628	66
PTS-RR51	77685	151	QMT-W	76075	25	RBPSR-L-CCT	28253	148	RSA150	73628	68
PTS-RR57	77686	151	QMT-W-S/S	77585	27	RBPSR-M	74563	148	RSA150	73628	71
PTS-RR63	77687	151	QMTBK-G	76540	25	RBPSR-M-CCT	28251	148	RSA150	73628	73
PTS-RR75	77689	151	QMTBK-G	76540	27	RBPSR-S	74562	148	RSA150	73628	87
PTS-SAK	77694	152	QMTBK-GCN	82174	107	RBPSR-S-CCT	28250	148	RSA150	73628	93
PTS-SR	77691	152	QMTBK-GCN	82174	108	RBPSR-XL	74565	148	RSA150	73628	100
PU150	73020	64	QMTBK-P	76097	25	RC-S/S	76250	66	RSA150 (V-Tip)	73628	84
PV1050	73010	63	QMTBK-P	76097	27	RC-S/S	76250	89	RSA150 (V-Tip)	73628	91
PV1050-S/S	75327	63	QMTBK-W	76098	25	RCAP-24/600	77921	87	RSA150 (V-Tip)	73628	98
PV1050-SAC	78023	77	QMTBK-W	76098	27	RCAP-24/600-S/S	78363	89	RV1050	74637	65
PV1050-SAC-S/S	78332	77	QMTBK-W	76098	32	RCAP-30/750	77922	87	RV1050-S/S	75345	65
PV1200	73012	63	QMTBK-W	76098	35	RCAP-30/750-S/S	78364	89	RV1050-SAC	78036	84
PV1200-S/S	75328	63	QMTBK-WS-MT	82175	107	RCAP-36/900	77923	87	RV1050-SAC-S/S	78345	84
PV1200-SAC	78024	77	QMTBK-WS-MT	82175	108	RCAP-36/900-S/S	78365	89	RV1200	74638	65
PV1200-SAC-S/S	78333	77	QMTPAK	76096	25	RCAP-42/1050	77924	87	RV1200-S/S	75346	65
PV1350-SAC	78025	77	QMTPAK-S/S	77587	27	RCAP-42/1050-S/S	78366	89	RV1200-SAC	78037	84
PV1350-SAC-S/S	78334	77	QMTPSBK	76099	25	RCAP-48/1200	77925	87	RV1200-SAC-S/S	78346	84
PV1400	73436	63	QMTPSBK-CN	82182	107	RCAP-48/1200-S/S	78367	89	RV1350-SAC	78038	84
PV1400-S/S	75329	63	QMTPSBK-S/S	77588	27	RCAP-54/1350	77926	87	RV1350-SAC-S/S	78347	84
PV1500	73437	63	QMTS-G	76484	25	RCAP-54/1350-S/S	78368	89	RV1400	74639	65
PV1500-2SAC	78028	77	QMTS-G-S/S	77452	18	RCAP-60/1500	77927	87	RV1400-S/S	75347	65
PV1500-2SAC-S/S	78337	77	QMTS-G-S/S	77452	27				RV1500	74640	65
PV1500-S/S	75330	63	QMTS-G-SS	77452	108				RV1500-2SAC	78041	84
PV1500-SAC	78026	77	QMTS-P	75845	17				RV1500-2SAC-S/S	78350	84
PV1500-SAC-S/S	78335	77	QMTS-P	75845	25				RV1500-S/S	75348	65
PV1800-2SAC	78029	77	QMTS-P	75845	107				RV1500-SAC	78039	84
PV1800-2SAC-S/S	78338	77	QMTS-P-S/S	77450	18				RV1500-SAC-S/S	78348	84
PV1800-SAC	78027	77	QMTS-P-S/S	77450	27				RV1800-2SAC	78042	84
PV1800-SAC-S/S	78336	77	QMTS-P-SS	77450	108				RV1800-2SAC-S/S	78351	84
PV1950-2SAC-S/S	78656	77	QMTS-W-S/S	77451	18				RV1800-SAC	78040	84
PV2100-2SAC	78030	77	QMTS-W-SS	77451	108				RV1800-SAC-S/S	78349	84
PV2100-2SAC-S/S	78339	77	QSTS-W-S/S	77451	27				RV1950-2SAC-S/S	78663	84

INDEX By Ordering Number

Ordering Number	Item Code	Page #	Ordering Number	Item Code	Page #	Ordering Number	Item Code	Page #	Ordering Number	Item Code	Page #
RV2100-2SAC	78043	84	SACPL-36/900	77889	79	SACPL2-72/1800	77896	100	SB1200A	A0316	118
RV2100-2SAC-S/S	78352	84	SACPL-36/900	77889	86	SACPL2-72/1800-S/S	78380	81	SB1400-SEC	61068	118
RV2400-2SAC	78044	84	SACPL-36/900	77889	93	SACPL2-72/1800-S/S	78380	88	SB1400A	A1620	118
RV2400-2SAC-S/S	78353	84	SACPL-36/900	77889	100	SACPL2-72/1800-S/S	78380	95	SB1500-SEC	61069	118
RV3000-2SAC	78045	84	SACPL-36/900-S/S	78373	81	SACPL2-72/1800-S/S	78380	101	SB1500A	A1838	118
RV3000-2SAC-S/S	78354	84	SACPL-36/900-S/S	78373	88	SACPL2-78/1950-S/S	78642	81	SB1800-SEC	61070	118
RV450	74633	65	SACPL-36/900-S/S	78373	95	SACPL2-78/1950-S/S	78642	88	SB1800A	A1357	118
RV450-S/S	75341	65	SACPL-36/900-S/S	78373	101	SACPL2-78/1950-S/S	78642	95	SB4	78789	127
RV600	74634	65	SACPL-42/1050	77890	79	SACPL2-78/1950-S/S	78642	101	SB4	78789	129
RV600-S/S	75342	65	SACPL-42/1050	77890	86	SACPL2-84/2100	77897	79	SB4	78789	131
RV600-SAC	78033	84	SACPL-42/1050	77890	93	SACPL2-84/2100	77897	86	SB4	78789	133
RV600-SAC-S/S	78342	84	SACPL-42/1050	77890	100	SACPL2-84/2100	77897	93	SB5	78790	127
RV750	74635	65	SACPL-42/1050-S/S	78374	81	SACPL2-84/2100	77897	100	SB5	78790	129
RV750-S/S	75343	65	SACPL-42/1050-S/S	78374	88	SACPL2-84/2100-S/S	78381	81	SB5	78790	131
RV750-SAC	78034	84	SACPL-42/1050-S/S	78374	95	SACPL2-84/2100-S/S	78381	88	SB5	78790	133
RV750-SAC-S/S	78343	84	SACPL-42/1050-S/S	78374	101	SACPL2-84/2100-S/S	78381	95	SB600-SEC	61063	118
RV900	74636	65	SACPL-48/1200	77891	79	SACPL2-84/2100-S/S	78381	101	SB600A	A0887	118
RV900-S/S	75344	65	SACPL-48/1200	77891	86	SACPL2-96/2400	77898	79	SB750-SEC	61064	118
RV900-SAC	78035	84	SACPL-48/1200	77891	93	SACPL2-96/2400	77898	86	SB750A	A0407	118
RV900-SAC-S/S	78344	84	SACPL-48/1200	77891	100	SACPL2-96/2400	77898	93	SB900-SEC	61065	118
RVHD1800	74642	65	SACPL-48/1200-S/S	78375	81	SACPL2-96/2400	77898	100	SB900A	A0912	118
RVHD1800-S/S	A1626	65	SACPL-48/1200-S/S	78375	88	SACPL2-96/2400-S/S	78382	81	SCU60	82812	107
RVHD2000	75463	65	SACPL-48/1200-S/S	78375	95	SACPL2-96/2400-S/S	78382	88	SCU60-S/S	82810	108
RVHD2100	74643	65	SACPL-48/1200-S/S	78375	101	SACPL2-96/2400-S/S	78382	95	SCUHD	82813	107
RVHD2100-S/S	A1628	65	SACPL-54/1350	77892	79	SACPL2-96/2400-S/S	78382	101	SCUHD-S/S	82811	108
RVHD2400	74644	65	SACPL-54/1350	77892	86	SACRH	77883	47	SHIM-KITH	77550	137
RVHD2400-S/S	A1610	65	SACPL-54/1350	77892	93	SACRH	77883	80	SHIM-KITL	77548	135
RVT6-S/S	76205	66	SACPL-54/1350	77892	100	SACRH	77883	87	SHIM-KITM	77549	136
RVT6-S/S	76205	68	SACPL-54/1350-S/S	78376	81	SACRH	77883	94	SHIM-LDKIT	82393	127
RVT6-S/S	76205	71	SACPL-54/1350-S/S	78376	88	SACRH	77883	100	SHIM-LDKIT	82393	129
RVT6-S/S	76205	73	SACPL-54/1350-S/S	78376	95	SACRH-S/S	78397	82	SHIM-LDKIT	82393	131
RVT6-S/S	76205	89	SACPL-54/1350-S/S	78376	101	SACRH-S/S	78397	89	SHIM-MDKIT	82394	133
RVT6-S/S	76205	96	SACPL-60/1500	77893	79	SACRH-S/S	78397	96	SKPU-6x1/2x25	90283	161
RVT6-S/S	76205	102	SACPL-60/1500	77893	86	SACRH-S/S	78397	102	SKPU-6x1/2x25	90285	161
SAC2-TIP-TL	77866	80	SACPL-60/1500	77893	93	SACRHL	77884	47	SKPU-6x3/4x25	90284	161
SAC2-TIP-TL	77866	82	SACPL-60/1500	77893	100	SACRHL	77884	80	SKPU-6x3/4x25	90286	161
SAC2-TIP-TL	77866	87	SACPL-60/1500-S/S	78377	81	SACRHL	77884	87	SMR-CCB-L60	A2844	120
SAC2-TIP-TL	77866	89	SACPL-60/1500-S/S	78377	88	SACRHL	77884	94	SMR-CCB-L73	A2842	80
SAC2-TIP-TL	77866	94	SACPL-60/1500-S/S	78377	95	SACRHL	77884	100	SMR-CCB-L73	A2842	87
SAC2-TIP-TL	77866	96	SACPL-60/1500-S/S	78377	101	SACRHL-S/S	78398	82	SMR-CCB-L73	A2842	100
SAC2-TIP-TL	77866	100	SACPL-72/1800	77894	79	SACRHL-S/S	78398	89	SMR-CCB-L73	A2842	120
SAC2-TIP-TL	77866	102	SACPL-72/1800	77894	86	SACRHL-S/S	78398	96	SMR-CCB-R60	A2845	120
SACKRP	77885	47	SACPL-72/1800	77894	93	SACRHL-S/S	78398	102	SMR-CCB-R73	A2843	80
SACKRP	77885	80	SACPL-72/1800	77894	100	SACRKN	77882	47	SMR-CCB-R73	A2843	87
SACKRP	77885	87	SACPL-72/1800-S/S	78378	81	SACRKN	77882	80	SMR-CCB-R73	A2843	100
SACKRP	77885	94	SACPL-72/1800-S/S	78378	88	SACRKN	77882	82	SMR-CCB-R73	A2843	120
SACKRP	77885	100	SACPL-72/1800-S/S	78378	95	SACRKN	77882	87	SPFC	79200	68
SACKRP-S/S	78399	82	SACPL-72/1800-S/S	78378	101	SACRKN	77882	89	SPFC	79200	71
SACKRP-S/S	78399	89	SACPL2-120/3000	77899	79	SACRKN	77882	94	SPFC	79200	73
SACKRP-S/S	78399	96	SACPL2-120/3000	77899	86	SACRKN	77882	96	SPFC	79200	93
SACKRP-S/S	78399	102	SACPL2-120/3000	77899	93	SACRKN	77882	100	SPFC	79200	100
SACPL-24/600	77887	79	SACPL2-120/3000	77899	100	SACRKN	77882	102	SPFC-S/S	79201	68
SACPL-24/600	77887	86	SACPL2-120/3000-S/S	78383	81	SACRKT	77886	80	SPFC-S/S	79201	71
SACPL-24/600	77887	93	SACPL2-120/3000-S/S	78383	88	SACRKT	77886	87	SPFC-S/S	79201	73
SACPL-24/600	77887	100	SACPL2-120/3000-S/S	78383	95	SACRKT	77886	94	SPFC-S/S	79201	96
SACPL-24/600-S/S	78371	81	SACPL2-120/3000-S/S	78383	101	SACRKT	77886	100	SPFC-S/S	79201	102
SACPL-24/600-S/S	78371	88	SACPL2-60/1500	77895	79	SACRKT-S/S	78401	82	SPG-CVR-A	77387	22
SACPL-24/600-S/S	78371	95	SACPL2-60/1500	77895	86	SACRKT-S/S	78401	89	SPG-CVR-A	77387	76
SACPL-24/600-S/S	78371	101	SACPL2-60/1500	77895	93	SACRKT-S/S	78401	96	SPG-CVR-A	77387	104
SACPL-30/750	77888	79	SACPL2-60/1500	77895	100	SACRKT-S/S	78401	102	SPG-CVR-B	77388	22
SACPL-30/750	77888	86	SACPL2-60/1500-S/S	78379	81	SACSK	77052	94	SPG-CVR-B	77388	76
SACPL-30/750	77888	93	SACPL2-60/1500-S/S	78379	88	SACSK	77052	96	SPG-CVR-B	77388	104
SACPL-30/750	77888	100	SACPL2-60/1500-S/S	78379	95	SACSRC	77065	94	SPG-CVR-C	77389	22
SACPL-30/750-S/S	78372	81	SACPL2-60/1500-S/S	78379	101	SACSRC	77065	96	SPG-CVR-C	77389	76
SACPL-30/750-S/S	78372	88	SACPL2-72/1800	77896	79	SB1050-SEC	61066	118	SPG-CVR-C	77389	104
SACPL-30/750-S/S	78372	95	SACPL2-72/1800	77896	86	SB1050A	A0435	118	SPG-CVR-D	77390	22
SACPL-30/750-S/S	78372	101	SACPL2-72/1800	77896	93	SB1200-SEC	61067	118	SPG-CVR-D	77390	76

INDEX By Ordering Number

Ordering Number	Item Code	Page #	Ordering Number	Item Code	Page #	Ordering Number	Item Code	Page #	Ordering Number	Item Code	Page #
SPG-CVR-D	77390	104	STJK	74417	42	TRB48	76490	25	URVB30/750	76738	105
SPG-CVR-E	77391	22	STJK	74417	42	TRB48	76490	27	URVB30/750	76738	105
SPG-CVR-E	77391	76	STJK-S/S	74417	107	TRB54	76491	23	URVB30/750	76738	106
SPG-CVR-E	77391	104	STJK-S/S	74417	108	TRB54	76491	25	URVB30/750	76738	106
SPG-CVR-F	77392	22	STJM	74775	42	TRB54	76491	27	URVB30/750	76738	109
SPG-CVR-F	77392	76	STJM	74775	42	TRB60	76492	23	URVB36/900	76739	105
SPG-CVR-F	77392	104	STJM	74775	107	TRB60	76492	25	URVB36/900	76739	105
SPG-CVR-G	77393	22	STJM-S/S	75426	42	TRB60	76492	27	URVB36/900	76739	106
SPG-CVR-G	77393	76	STJM-S/S	75426	42	TRB66	76493	23	URVB36/900	76739	106
SPG-CVR-G	77393	104	STJM-S/S	77332	108	TRB66	76493	25	URVB36/900	76739	109
SPG-CVR-H	77741	22	STKD	74504	42	TRB66	76493	27	URVB42/1050	76740	105
SPG-CVR-H	77741	76	STKD-S/S	75427	42	TRB72	76494	23	URVB42/1050	76740	105
SPG-CVR-H	77741	104	STLP	79535	113	TRB72	76494	25	URVB42/1050	76740	106
SRBK	74941	123	STS-B	75844	55	TRB72	76494	27	URVB42/1050	76740	106
SSFRB	78456	32	STS-B	75844	55	TRB78	76697	23	URVB42/1050	76740	109
SSFRB	78456	35	STS-B	75844	62	TRB78	76697	25	URVB48/1200	76741	105
SSRB	75978	32	STS-B	75844	68	TRB78	76697	27	URVB48/1200	76741	105
SSRB	75978	35	STS-B	75844	73	TRB84	77047	25	URVB48/1200	76741	106
SST1HDM-B	78519	73	STS-B	75844	94	TRB84	77047	27	URVB48/1200	76741	106
SST1HDM-B	78519	94	STS-B-S/S	77632	55	TRB90	77048	25	URVB48/1200	76741	109
SST1HDM-B-S/S	78396	73	STS-B-S/S	77632	55	TRB90	77048	27	URVB54/1350	76742	105
SST1HDM-B-S/S	78396	96	STS-B-S/S	77632	68	UFB18	74448	109	URVB54/1350	76742	105
SST1HDM-G	79069	73	STS-B-S/S	77632	73	UFB24	74449	109	URVB54/1350	76742	106
SST1HDM-G	79069	94	STS-B-S/S	77632	96	UFB30	74450	109	URVB54/1350	76742	106
SST1HDM-S	78518	73	STS-G	78142	55	UFB36	74451	109	URVB54/1350	76742	109
SST1HDM-S	78518	94	STS-G	78142	55	UFB42	74452	109	URVB56/1400	77314	105
SST1HDM-S-S/S	78395	73	STS-G	78142	68	UFB48	74453	109	URVB56/1400	77314	105
SST1HDM-S-S/S	78395	96	STS-G	78142	73	UFB54	74454	109	URVB56/1400	77314	106
SST1HDM-W	78517	73	STS-G	78142	94	UFB60	74455	109	URVB56/1400	77314	106
SST1HDM-W	78517	94	STS-G-S/S	79057	55	UFB72	74456	109	URVB56/1400	77314	109
SST1HDM-W-S/S	78394	73	STS-G-S/S	79057	55	UFB84	74460	109	URVB60/1500	76743	105
SST1HDM-W-S/S	78394	96	STS-G-S/S	79057	68	UHPB	76787	107	URVB60/1500	76743	105
SSTBK-B	76637	73	STS-S	75843	62	UHPB	76787	108	URVB60/1500	76743	106
SSTBK-B	76637	73	STS-S	75843	68	UHPB2	79207	107	URVB60/1500	76743	106
SSTBK-B	76637	94	STS-S	75843	73	UHPB2	79207	108	URVB60/1500	76743	109
SSTBK-B	76637	96	STS-S	75843	94	UHSPK-M	82887	107	URVB64/1600	77315	105
SSTBK-W	76636	73	STS-S-S/S	77631	68	UHSPK-SS-M	82889	108	URVB64/1600	77315	105
SSTBK-W	76636	73	STS-S-S/S	77631	73	UMBK-M	82890	107	URVB64/1600	77315	106
SSTBK-W	76636	94	STS-S-S/S	77631	96	UMBK-SS-M	82891	108	URVB64/1600	77315	106
SSTBK-W	76636	96	STS-W	75846	68	UNB60	61369	42	URVB64/1600	77315	109
SSTHDMK	77870	73	STS-W	75846	73	UNB73	A2671	42	URVB72/1800	76744	105
SSTHDMK	77870	93	STS-W	75846	94	URCB18/450	76748	109	URVB72/1800	76744	105
SSTHDPM	77868	73	STS-W-S/S	77630	68	URCB24/600	76749	109	URVB72/1800	76744	106
SSTHDPM	77868	94	STS-W-S/S	77630	73	URCB30/750	76750	109	URVB72/1800	76744	106
SSTHK	79070	73	STS-W-S/S	77630	96	URCB36/900	76751	109	URVB72/1800	76744	109
SSTHK-S/S	79071	73	STTS	74419	42	URCB42/1050	76752	109	URVB80/2000	77320	105
SSTLMB	76072	124	STTS	74419	107	URCB48/1200	76753	109	URVB80/2000	77320	105
SSTOTA	76073	124	STTS-S/S	75585	108	URCB54/1350	76754	109	URVB80/2000	77320	106
SSTSMB	76071	124	TEN-LOCK-KIT	77443	22	URCB56/1400	77317	109	URVB80/2000	77320	106
STAK	75847	73	TEN-LOCK-KIT	77443	76	URCB60/1500	76755	109	URVB80/2000	77320	109
STAK	75847	73	TEN-LOCK-KIT	77443	104	URCB64/1600	77318	109	URVB84/2100	76745	105
STAK	75847	94	TRB18	76485	23	URCB72/1800	76756	109	URVB84/2100	76745	105
STAK	75847	96	TRB18	76485	25	URCB80/2000	77321	109	URVB84/2100	76745	106
STAKHD	75892	73	TRB18	76485	27	URCB84/2100	76757	109	URVB84/2100	76745	106
STAKHD	75892	73	TRB24	76486	23	URCB88/2200	76319	109	URVB84/2100	76745	109
STAKHD	75892	94	TRB24	76486	25	URCB94/2400	77448	109	URVB88/2200	77316	105
STAKHD	75892	96	TRB24	76486	27	URCB98/2500	77449	109	URVB88/2200	77316	105
STCK	74506	42	TRB30	76487	23	URVB18/450	76736	105	URVB88/2200	77316	106
STCK-S/S	75425	42	TRB30	76487	25	URVB18/450	76736	105	URVB88/2200	77316	106
STGK2	77635	73	TRB30	76487	27	URVB18/450	76736	106	URVB88/2200	77316	109
STGK2	77635	73	TRB36	76488	23	URVB18/450	76736	106	URVB94/2400	77421	105
STGK2	77635	94	TRB36	76488	25	URVB18/450	76736	109	URVB94/2400	77421	105
STGK2	77635	96	TRB36	76488	27	URVB24/600	76737	105	URVB94/2400	77421	106
STHDMK2-S/S	77634	73	TRB42	76489	23	URVB24/600	76737	105	URVB94/2400	77421	106
STHDMK2-S/S	77634	96	TRB42	76489	25	URVB24/600	76737	106	URVB94/2400	77421	109
STHDPM2-S/S	77633	73	TRB42	76489	27	URVB24/600	76737	106	URVB98/2500	77422	105
STHDPM2-S/S	77633	96	TRB48	76490	23	URVB24/600	76737	109	URVB98/2500	77422	105

INDEX By Ordering Number

Ordering Number	Item Code	Page #	Ordering Number	Item Code	Page #	Ordering Number	Item Code	Page #	Ordering Number	Item Code	Page #
URVB98/2500	77422	106	UTV1350-J	77289	106	YCART-24/600-P	79618	58	YT-TC-1050S	83245	56
URVB98/2500	77422	106	UTV1350-S/S	82713	105	YCART-24/600-TC	79812	58	YT-TC-1200S	83246	56
URVB98/2500	77422	109	UTV1350J-S/S	77265	106	YCART-30/750-P	79619	58	YT-TC-450S	83241	56
USP18/450	82689	107	UTV1400	77304	105	YCART-30/750-TC	79813	58	YT-TC-600S	83242	56
USP18/450-S/S	77339	108	UTV1400-J	77290	106	YCART-36/900-HDP	79817	58	YT-TC-750S	83243	56
USP24/600	82690	107	UTV1400-S/S	82714	105	YCART-36/900-HDTC	79829	58	YT-TC-900S	83244	56
USP24/600-S/S	77340	108	UTV1400J-S/S	77266	106	YCART-36/900-P	79620	58	YTA-18/450	82949	61
USP30/750	82691	107	UTV1500	77305	105	YCART-36/900-TC	79814	58	YTA-24/600	82950	61
USP30/750-S/S	77341	108	UTV1500-J	77291	106	YCART-36/900-HDP	79818	58	YTA-30/750	82951	61
USP36/900	82692	107	UTV1500-S/S	82715	105	YCART-42/1050-HDTC	79830	58	YTA-36/900	82952	61
USP36/900-S/S	77342	108	UTV1500J-S/S	77267	106	YCART-42/1050-P	79621	58	YTA-42/1050	82953	61
USP42/1050	82693	107	UTV1600	77306	105	YCART-42/1050-TC	79815	58	YTA-48/1200	82954	61
USP42/1050-S/S	77343	108	UTV1600-J	77292	106	YCART-48/1200-HDP	79819	58	YTAC	79623	61
USP48/1200	82694	107	UTV1600-S/S	82716	105	YCART-48/1200-HDTC	79831	58	YTACHD	79835	62
USP48/1200-S/S	77344	108	UTV1600J-S/S	77268	106	YCART-48/1200-P	79622	58	YTAHD-36/900	79805	62
USP54/1350	82695	107	UTV1800	77307	105	YCART-48/1200-TC	79816	58	YTAHD-42/1050	79806	62
USP54/1350-S/S	77345	108	UTV1800-J	77293	106	YCART-54/1350-HDP	79820	58	YTAHD-48/1200	79807	62
USP56/1400	82696	107	UTV1800-S/S	82717	105	YCART-54/1350-HDTC	79832	58	YTAHD-54/1350	79808	62
USP56/1400-S/S	77346	108	UTV1800J-S/S	77269	106	YCART-60/1500-HDP	79821	58	YTAHD-60/1500	79809	62
USP60/1500	82697	107	UTV2000	77308	105	YCART-60/1500-HDTC	79833	58	YTAHD-72/1800	79810	62
USP60/1500-S/S	77347	108	UTV2000-J	77294	106	YCART-72/1800-HDP	79822	58	YTC-1050	83227	56
USP64/1600	82698	107	UTV2000-S/S	82718	105	YCART-72/1800-HDTC	79834	58	YTC-1200	83228	56
USP64/1600-S/S	77348	108	UTV2000J-S/S	77270	106	YST-P	79837	61	YTC-450	83223	56
USP72/1800	82699	107	UTV2100	77309	105	YST-S	79838	61	YTC-600	83224	56
USP72/1800-S/S	77349	108	UTV2100-J	77295	106	YST-Y	79836	61	YTC-750	83225	56
USP80/2000	82700	107	UTV2100-S/S	82719	105	YSTANK	79857	61	YTC-900	83226	56
USP80/2000-S/S	77350	108	UTV2100J-S/S	77271	106	YSTANK	79858	62	YTCHD-1050	83100	57
USP84/2100	82701	107	UTV2200	77310	105	YSTDBK	79844	61	YTCHD-1200	83101	57
USP84/2100-S/S	77351	108	UTV2200-J	77296	106	YSTGBK	79845	61	YTCHD-1350	83102	57
USP88/2200	82702	107	UTV2200-S/S	82720	105	YSTHD-BK	79842	62	YTCHD-1500	83103	57
USP88/2200-S/S	77352	108	UTV2200J-S/S	77272	106	YSTHD-BL	79841	62	YTCHD-1800	83105	57
USP94/2400	82703	107	UTV2400	77411	105	YSTHD-GR	79839	62	YTCHD-900	83099	57
USP94/2400-S/S	77419	108	UTV2400-J	77413	106	YSTHD-S	79840	62	YTHD-1050S	83121	57
USP98/2500	82704	107	UTV2400-S/S	82721	105	YSTHDBK-B	79856	62	YTHD-1200S	83122	57
USP98/2500-S/S	77418	108	UTV2400J-S/S	77417	106	YSTHDBK-W	79853	62	YTHD-1350S	83123	57
USPB	76786	107	UTV2500	77412	105	YSTHDBK	79850	62	YTHD-1500S	83124	57
USPB	76786	108	UTV2500-J	77414	106	YSTHDGBK	79851	62	YTHD-1800S	83126	57
USPB2	79206	107	UTV2500-S/S	82722	105	YSTHDLBK	79852	62	YTHD-900S	83120	57
USPB2	79206	108	UTV2500J-S/S	77418	106	YSTHDMB	79849	62	YTHD-TC-1050S	83135	57
USPK	76790	107	UTV450	77297	105	YSTHDS-BL	79798	62	YTHD-TC-1200S	83136	57
USPK-SS-M	82888	108	UTV450-J	77283	106	YSTHDS-GR	79797	62	YTHD-TC-1350S	83137	57
UST-G-MT	82900	107	UTV450-S/S	82707	105	YSTLBK	79846	61	YTHD-TC-1500S	83138	57
UST-G-MT-SS	82904	108	UTV450J-S/S	77259	106	YSTMB	79843	61	YTHD-TC-1800S	83140	57
UST-P-MT	82897	107	UTV600	77298	105	YSTPHDMK	79854	62	YTHD-TC-900S	83134	57
UST-P-MT-SS	82901	108	UTV600-J	77284	106	YSTPMK	79848	61	YTP-18/450	82932	61
UST-S-MT	82898	107	UTV600-S/S	82708	105	YSTS-P	79796	61	YTP-24/600	82933	61
UST-S-MT-SS	82902	108	UTV600J-S/S	77260	106	YSTS-Y	79795	61	YTP-30/750	82934	61
UST-W-MT	82899	107	UTV750	77299	105	YSTTBK-B	79855	61	YTP-36/900	82935	61
UST-W-MT-SS	82903	108	UTV750-J	77285	106	YSTTBK-W	79847	61	YTP-42/1050	82936	61
UTS	74420	42	UTV750-S/S	82709	105	YT-1050S	83233	56	YTP-48/1200	82937	61
UTV1050	77301	105	UTV750J-S/S	77261	106	YT-1200S	83234	56	YTPHD-36/900	83106	62
UTV1050-J	77287	106	UTV900	77300	105	YT-450S	83229	56	YTPHD-42/1050	83107	62
UTV1050-S/S	82711	105	UTV900-J	77286	106	YT-600S	83230	56	YTPHD-48/1200	83108	62
UTV1050J-S/S	77263	106	UTV900-S/S	82710	105	YT-750S	83231	56	YTPHD-54/1350	83109	62
UTV1200	77302	105	UTV900J-S/S	77262	106	YT-900S	83232	56	YTPHD-60/1500	83110	62
UTV1200-J	77288	106	WCB	A0012	118	YT-C*	79574	58	YTPHD-72/1800	83112	62
UTV1200-S/S	82712	105	WCB	A0012	119	YT-HDC*	79728	58		77729	162
UTV1200J-S/S	77264	106	YCART-18/450-P	79617	58	YT-HDP*	79677	58			
UTV1350	77303	105	YCART-18/450-TC	79811	58	YT-P*	79573	58			

INDEX By Item Code

Item Code	Ordering Number	Page #	Item Code	Ordering Number	Page #	Item Code	Ordering Number	Page #	Item Code	Ordering Number	Page #
26107	N6D3T-24-9-A45	127	61068	SB1400-SEC	118	61533	MHCP-S/S-CP 2100	35	61797	FBP1500-1600-MF	144
26108	N6D3T-30-11-A45	127	61069	SB1500-SEC	118	61534	MHCP-SS/EP	35	61798	FBP1800-2000-MF	144
26109	N6D3T-36-13-A45	127	61070	SB1800-SEC	118	61535	MHCP-S/S-CK600	35	61799	FBP2200-2400-MF	144
26110	N6D3T-42-15-A45	127	61073	PMR-CHB-L60	120	61536	MHCP-S/S-CK750	35	61800	FBP2500-2600-MF	144
26111	N6D3T-48-17-A45	127	61074	PMR-CHB-R60	120	61537	MHCP-S/S-CK900	35	61803	FBP900-1050-MF-S/S	144
26112	N6D3T-54-19-A45	127	61075	PMR-CHB-L73	120	61538	MHCP-S/S-CK1050	35	61804	FBP1200-1400-MF-S/S	144
26113	N6D3T-60-21-A45	127	61076	PMR-CHB-R73	120	61539	MHCP-S/S-CK1200	35	61805	FBP1500-1600-MF-S/S	144
26114	N6D3T-72-25-A45	127	61077	CBD-ST-M	146	61540	MHCP-S/S-CK1350	35	61806	FBP1800-2000-MF-S/S	144
26184	NI6D3T-24-9-A45	129	61079	CBD-ST-M-S/S	146	61541	MHCP-S/S-CK1500	35	61807	FBP2200-2400-MF-S/S	144
26185	NI6D3T-30-11-A45	129	61080	CBD-ST-L-S/S	146	61542	MHCP-S/S-CK1650	35	61808	FBP2500-2600-MF-S/S	144
26186	NI6D3T-36-13-A45	129	61081	EZP1-218-S/S	15	61543	MHCP-S/S-CK1800	35	61875	FBP-NP	144
26187	NI6D3T-42-15-A45	129	61082	EZP1-224-S/S	15	61544	MHCP-S/S-CK2100	35	61876	FBP-NP-S/S	144
26188	NI6D3T-48-17-A45	129	61083	EZP1-236-S/S	15	61545	MHCP-S/S-CLP	35	61877	HBP2600-PL-TP-S/S	144
26189	NI6D3T-54-19-A45	129	61084	EZP1-248-S/S	15	61546	MHCP-S/S-PSTW	35	61882	FBP-LM	144
26190	NI6D3T-60-21-A45	129	61085	EZP1-254-S/S	15	61547	MHCP-S/S-PSTS	35	61883	FBP-LM-S/S	144
26191	NI6D3T-72-25-A45	129	61086	EZP1-260-S/S	15	61548	MHCP-S/S-CH	35	61888	FBP-FP	144
26714	NS6DV-18-9.625-A45	154	61087	EZP1-272-S/S	15	61549	MHCP-S/S-CEB	35	61889	FBP-FP-S/S	144
26714	NS6DV-18-9.625-A45	156	61096	CBD-ST-AA	146	61550	MHCP-S/S-CBK	35	61890	FBP900-1050-PP	144
26715	NS6DV-24-12.625-A45	154	61097	CBD-ST-AA-S/S	146	61624	MHCP-600S-S/S-FR	33	61891	FBP1200-1400-PP	144
26715	NS6DV-24-12.625-A45	156	61100	CBD-ST-HN-S/S	146	61625	MHCP-750S-S/S-FR	33	61892	FBP1500-1600-PP	144
26716	NS6DV-30-15.625-A45	154	61100	CBD-ST-HN-S/S	146	61626	MHCP-900S-S/S-FR	33	61893	FBP1800-2000-PP	144
26716	NS6DV-30-15.625-A45	156	61105	CBD-ST-M-MF	146	61627	MHCP-1050S-S/S-FR	33	61894	FBP2200-2400-PP	144
26717	NS6DV-36-18.625-A45	154	61106	CBD-ST-L-MF	146	61628	MHCP-1200S-S/S-FR	33	61895	FBP2500-2600-PP	144
26717	NS6DV-36-18.625-A45	156	61107	CBD-ST-XL-MF	146	61629	MHCP-1350S-S/S-FR	33	61898	FBP900-1050-PP-S/S	144
26718	NS6DV-42-21.625-A45	154	61108	CBD-ST-M-MF-S/S	146	61630	MHCP-1500S-S/S-FR	33	61899	FBP1200-1400-PP-S/S	144
26718	NS6DV-42-21.625-A45	156	61109	CBD-ST-L-MF-S/S	146	61631	MHCP-1650S-S/S-FR	33	61900	FBP1500-1600-PP-S/S	144
26719	NS6DV-48-24.625-A45	154	61110	CBD-ST-XL-MF-S/S	146	61632	MHCP-1800S-S/S-FR	33	61901	FBP1800-2000-PP-S/S	144
26719	NS6DV-48-24.625-A45	156	61111	CBD-ST-B	146	61633	MHCP-2100S-S/S-FR	33	61902	FBP2200-2400-PP-S/S	144
26720	NS6DV-54-27.625-A45	154	61111	CBD-ST-B	146	61634	MHCP-S/S-CP 600	35	61903	FBP2500-2600-PP-S/S	144
26720	NS6DV-54-27.625-A45	156	61112	CBD-ST-M-FP	146	61750	FBP900-TP	143	61906	FBP900-1050-SP	144
26721	NS6DV-60-30.625-A45	154	61112	CBD-ST-M-FP	146	61751	FBP1050-TP	143	61907	FBP1200-1400-SP	144
26721	NS6DV-60-30.625-A45	156	61113	CBD-ST-L-FP	146	61752	FBP1200-TP	143	61908	FBP1500-1600-SP	144
26722	NS6DV-72-36.625-A45	154	61113	CBD-ST-L-FP	146	61753	FBP1400-TP	143	61909	FBP1800-2000-SP	144
26722	NS6DV-72-36.625-A45	156	61114	CBD-ST-XL-FP	146	61754	FBP1500-TP	143	61910	FBP2200-2400-SP	144
26723	NS7DV-48-24.625-A105	154	61114	CBD-ST-XL-FP	146	61755	FBP1600-TP	143	61911	FBP2500-2600-SP	144
26723	NS7EV-48-24.625-A105	156	61173	HSTSS	42	61756	FBP1800-TP	143	61914	FBP900-1050-SP-S/S	144
26724	NS7DV-54-27.625-A105	154	61182	EZP1P18-S/S	18	61757	FBP2000-TP	143	61915	FBP1200-1400-SP-S/S	144
26724	NS7EV-54-27.625-A105	156	61183	EZP1P42-S/S	18	61758	FBP2200-TP	143	61916	FBP1500-1600-SP-S/S	144
26725	NS7DV-60-30.625-A105	154	61184	EZP1P54-S/S	18	61759	FBP2400-TP	143	61917	FBP1800-2000-SP-S/S	144
26725	NS7EV-60-30.625-A105	156	61185	EZP1P60-S/S	18	61760	FBP2500-TP	143	61918	FBP2200-2400-SP-S/S	144
26726	NS7DV-72-36.625-A105	154	61186	EZP1P72-S/S	18	61761	FBP2600-TP	143	61919	FBP2500-2600-SP-S/S	144
26726	NS7EV-72-36.625-A105	156	61270	RPHD2000-S/S	66	61765	FBP900-TP S/S	143	62034	AIR HDMRK S/S	55
26727	NS7DV-84-42.625-A105	154	61271	RPHD2400-S/S	66	61766	FBP1050-TP S/S	143	62035	AIR HARK-S/S-60	55
26727	NS7EV-84-42.625-A105	156	61356	PBC-1	162	61767	FBP1200-TP S/S	143	62036	AIR BAG P	55
26728	NS7DV-96-48.625-A105	154	61357	PBC-2	162	61768	FBP1400-TP S/S	143	62036	ATV-BAG	69
26728	NS7EV-96-48.625-A105	156	61358	PBC-FR	162	61769	FBP1500-TP S/S	143	62036	ATV-BAG	74
28250	RBPSR-S-CCT	148	61369	UNB60	42	61770	FBP1600-TP S/S	143	62036	ATV-BAG	94
28251	RBPSR-M-CCT	148	61471	FLSCM2000-S/S	160	61771	FBP1800-TP S/S	143	62037	ATV-NIP	55
28253	RBPSR-L-CCT	148	61491	EZP1P48-S/S	18	61772	FBP2000-TP S/S	143	62037	ATV-NIP	69
28254	RBPSR-XL-CCT	148	61504	MHCP-600S-S/S	33	61773	FBP2200-TP S/S	143	62037	ATV-NIP	74
30001	EBC-1	162	61505	MHCP-750S-S/S	33	61774	FBP2400-TP S/S	143	62037	ATV-NIP	94
30002	EBC-2	162	61506	MHCP-900S-S/S	33	61775	FBP2500-TP S/S	143	62095	CRHMK-S/S	82
30003	EBC-1-B	162	61507	MHCP-1050S-S/S	33	61776	FBP2600-TP S/S	143	62095	CRHMK-S/S	89
30004	EBC-2-B	162	61508	MHCP-1200S-S/S	33	61780	FBP900-B	143	62095	CRHMK-S/S	102
30018	CEBC-1	162	61509	MHCP-1350S-S/S	33	61781	FBP1050-B	143	62254	HVT8-EL15-S/S	53
30019	CEBC-2	162	61510	MHCP-1500S-S/S	33	61782	FBP1200-B	143	62350	PSR-S-F	147
30033	EBC1-RK	162	61511	MHCP-1650S-S/S	33	61783	FBP1400-B	143	62351	PSR-M-F	147
30034	EBC2-RK	162	61512	MHCP-1800S-S/S	33	61784	FBP1500-B	143	62352	PSR-L-F	147
61016	EZP1-242-S/S	15	61513	MHCP-2100S-S/S	33	61785	FBP1600-B	143	62353	PSR-XL-F	147
61017	EZP1-230-S/S	15	61525	MHCP-S/S-CP 750	35	61786	FBP1800-B	143	62400	CRHMK	80
61050	CBD-ST-L	146	61526	MHCP-S/S-CP 900	35	61787	FBP2000-B	143	62400	CRHMK	87
61051	CBD-ST-XL	146	61527	MHCP-S/S-CP 1050	35	61788	FBP2200-B	143	62400	CRHMK	100
61063	SB600-SEC	118	61528	MHCP-S/S-CP 1200	35	61789	FBP2400-B	143	62409	ATVK-60	69
61064	SB750-SEC	118	61529	MHCP-S/S-CP 1350	35	61790	FBP2500-B	143	62409	ATVK-60	74
61065	SB900-SEC	118	61530	MHCP-S/S-CP 1500	35	61791	FBP2600-B	143	62409	ATVK-60	94
61066	SB1050-SEC	118	61531	MHCP-S/S-CP 1650	35	61795	FBP900-1050-MF	144	62424	ATV-MOUNT	69
61067	SB1200-SEC	118	61532	MHCP-S/S-CP 1800	35	61796	FBP1200-1400-MF	144	62424	ATV-MOUNT	74

INDEX By Item Code

Item Code	Ordering Number	Page #	Item Code	Ordering Number	Page #	Item Code	Ordering Number	Page #	Item Code	Ordering Number	Page #
62424	ATV-MOUNT	94	62456	H-SAC-AP-1400	54	62514	HCSBB-73	55	62582	HV-1600-2SAC-CL-S/S	45
62425	ATV-SLIDE	69	62456	H-SAC-AP-1400	54	62514	HCSBB-73	55	62589	HCSSB-B/G	55
62425	ATV-SLIDE	74	62456	H-SAC-AP-1400	54	62515	HV-600-SAC-CS	43	62589	HCSSB-B/G	55
62425	ATV-SLIDE	94	62456	H-SAC-AP-1400	54	62516	HV-600-SAC-CM	43	62589	HCSSB-B/G	55
62426	ATV-ANGLE	69	62456	H-SAC-AP-1400	54	62517	HV-600-SAC-CL	43	62589	HCSSB-B/G	55
62426	ATV-ANGLE	74	62457	H-SAC-AP-1600	47	62518	HV-800-SAC-CS	43	62590	HCSSB-S	55
62426	ATV-ANGLE	94	62457	H-SAC-AP-1600	48	62519	HV-800-SAC-CM	43	62590	HCSSB-S	55
62445	ID300x300		62457	H-SAC-AP-1600	53	62520	HV-800-SAC-CL	43	62591	ACME-N	55
	S/S Inspection Door	116	62457	H-SAC-AP-1600	54	62521	HV-1000-SAC-CS	43	62591	ACME-N	55
62446	ID400x400		62458	H-SAC-AP-1800	47	62522	HV-1000-SAC-CM	43	62591	ACME-N	55
	S/S Inspection Door	116	62458	H-SAC-AP-1800	53	62523	HV-1000-SAC-CL	43	62591	ACME-N	55
62447	ID500x500		62494	HCSTAK	55	62524	HV-1200-SAC-CS	43	62599	H-CARK2-1200-CS	44
	S/S Inspection Door	116	62495	HCSTAK-S/S	55	62525	HV-1200-SAC-CM	43	62600	H-CARK2-1200-CM	44
62448	ID600x600		62496	ACME-PRK	55	62526	HV-1200-SAC-CL	43	62601	H-CARK2-1200-CL	44
	S/S Inspection Door	116	62496	ACME-PRK	55	62527	HV-1400-SAC-CS	43	62602	H-CARK2-1200-CM	44
62452	H-SAC-AP-600	47	62496	ACME-PRK	55	62528	HV-1400-SAC-CM	43	62603	H-CARK2-1400-CS	44
62452	H-SAC-AP-600	48	62496	ACME-PRK	55	62529	HV-1400-SAC-CL	43	62604	H-CARK2-1400-CM	44
62452	H-SAC-AP-600	48	62505	HSA8CS	43	62530	HV-1600-SAC-CM	43	62605	H-CARK2-1400-CL	44
62452	H-SAC-AP-600	48	62505	HSA8CS	47	62531	HV-1600-SAC-CL	43	62606	H-CARK2-1400-CLL	44
62452	H-SAC-AP-600	53	62505	HSA8CS	48	62532	HV-1600-SAC-CLL	43	62607	H-CARK2-1600-CM	44
62452	H-SAC-AP-600	54	62505	HSA8CS	49	62533	HV-1800-SAC-CM	43	62608	H-CARK2-1600-CL	44
62452	H-SAC-AP-600	54	62505	HSA8CS	53	62534	HV-1800-SAC-CL	43	62609	H-CARK2-1600-CLL	44
62452	H-SAC-AP-600	54	62505	HSA8CS	54	62535	HV-1800-SAC-CLL	43	62610	H-CARK2-1800-CM	44
62452	H-SAC-AP-600	54	62506	HSA8CM	43	62536	H-CARK-600-CS	44	62611	H-CARK2-1800-CL	44
62453	H-SAC-AP-800	47	62506	HSA8CM	47	62537	H-CARK-600-CM	44	62612	H-CARK2-1800-CLL	44
62453	H-SAC-AP-800	48	62506	HSA8CM	48	62538	H-CARK-600-CL	44	62613	H-CARK2-2000-CM	44
62453	H-SAC-AP-800	48	62506	HSA8CM	49	62539	H-CARK-800-CS	44	62614	H-CARK2-2000-CL	44
62453	H-SAC-AP-800	48	62506	HSA8CM	53	62540	H-CARK-800-CM	44	62615	H-CARK2-2000-CLL	44
62453	H-SAC-AP-800	48	62506	HSA8CM	54	62541	H-CARK-800-CL	44	62616	H-CARK2-2200-CM	44
62453	H-SAC-AP-800	53	62507	HSA8CL	43	62542	H-CARK-1000-CS	44	62617	H-CARK2-2200-CL	44
62453	H-SAC-AP-800	54	62507	HSA8CL	47	62543	H-CARK-1000-CM	44	62618	H-CARK2-2200-CLL	44
62453	H-SAC-AP-800	54	62507	HSA8CL	48	62544	H-CARK-1000-CL	44	62619	H-CARK2-2400-CM	44
62453	H-SAC-AP-800	54	62507	HSA8CL	49	62545	H-CARK-1200-CS	44	62620	H-CARK2-2400-CL	44
62453	H-SAC-AP-800	54	62507	HSA8CL	53	62546	H-CARK-1200-CM	44	62621	H-CARK2-2400-CLL	44
62453	H-SAC-AP-800	54	62507	HSA8CL	54	62547	H-CARK-1200-CL	44	62622	H-CARK2-2600-CM	44
62453	H-SAC-AP-800	54	62508	HSA8CLL	43	62548	H-CARK-1400-CS	44	62623	H-CARK2-2600-CL	44
62454	H-SAC-AP-1000	47	62508	HSA8CLL	47	62549	H-CARK-1400-CM	44	62624	H-CARK2-2600-CLL	44
62454	H-SAC-AP-1000	48	62508	HSA8CLL	48	62550	H-CARK-1400-CL	44	62625	H-CARK2-2800-CM	44
62454	H-SAC-AP-1000	48	62508	HSA8CLL	49	62551	H-CARK-1600-CS	44	62626	H-CARK2-2800-CL	44
62454	H-SAC-AP-1000	48	62508	HSA8CLL	53	62552	H-CARK-1600-CM	44	62627	H-CARK2-2800-CLL	44
62454	H-SAC-AP-1000	48	62508	HSA8CLL	54	62553	H-CARK-1600-CL	44	62628	H-CARK2-3000-CM	44
62454	H-SAC-AP-1000	53	62509	HSA8CS-S/S	45	62554	H-CARK-1800-CS	44	62629	H-CARK2-3000-CL	44
62454	H-SAC-AP-1000	54	62509	HSA8CS-S/S	47	62555	H-CARK-1800-CM	44	62630	H-CARK2-3000-CLL	44
62454	H-SAC-AP-1000	54	62509	HSA8CS-S/S	48	62556	H-CARK-1800-CL	44	62631	HV-600-SAC-CS-S/S	45
62454	H-SAC-AP-1000	54	62509	HSA8CS-S/S	51	62557	HV-1200-2SAC-CS	43	62632	HV-600-SAC-CM-S/S	45
62454	H-SAC-AP-1000	54	62509	HSA8CS-S/S	53	62558	HV-1200-2SAC-CM	43	62633	HV-600-SAC-CL-S/S	45
62454	H-SAC-AP-1000	54	62509	HSA8CS-S/S	54	62559	HV-1200-2SAC-CL	43	62634	HV-800-SAC-CS-S/S	45
62454	H-SAC-AP-1000	54	62510	HSA8CM-S/S	45	62560	HV-1200-2SAC-CLL	43	62635	HV-800-SAC-CM-S/S	45
62455	H-SAC-AP-1200	47	62510	HSA8CM-S/S	47	62561	HV-1400-2SAC-CS	43	62636	HV-800-SAC-CL-S/S	45
62455	H-SAC-AP-1200	48	62510	HSA8CM-S/S	48	62562	HV-1400-2SAC-CM	43	62637	HV-1000-SAC-CS-S/S	45
62455	H-SAC-AP-1200	48	62510	HSA8CM-S/S	51	62563	HV-1400-2SAC-CL	43	62638	HV-1000-SAC-CM-S/S	45
62455	H-SAC-AP-1200	48	62510	HSA8CM-S/S	53	62564	HV-1400-2SAC-CLL	43	62639	HV-1000-SAC-CL-S/S	45
62455	H-SAC-AP-1200	48	62510	HSA8CM-S/S	54	62565	HV-1600-2SAC-CM	43	62640	HV-1200-SAC-CS-S/S	45
62455	H-SAC-AP-1200	53	62511	HSA8CL-S/S	45	62566	HV-1600-2SAC-CL	43	62641	HV-1200-SAC-CM-S/S	45
62455	H-SAC-AP-1200	54	62511	HSA8CL-S/S	47	62567	HV-1600-2SAC-CLL	43	62642	HV-1200-SAC-CL-S/S	45
62455	H-SAC-AP-1200	54	62511	HSA8CL-S/S	48	62568	HV-1800-2SAC-CM	43	62643	HV-1400-SAC-CS-S/S	45
62455	H-SAC-AP-1200	54	62511	HSA8CL-S/S	51	62569	HV-1800-2SAC-CL	43	62644	HV-1400-SAC-CM-S/S	45
62455	H-SAC-AP-1200	54	62511	HSA8CL-S/S	53	62570	HV-1800-2SAC-CLL	43	62645	HV-1400-SAC-CL-S/S	45
62455	H-SAC-AP-1200	54	62511	HSA8CL-S/S	54	62571	HV-2000-2SAC-CM	43	62646	HV-1600-SAC-CM-S/S	45
62455	H-SAC-AP-1200	54	62512	HSA8CLL-S/S	45	62572	HV-2000-2SAC-CL	43	62647	HV-1600-SAC-CL-S/S	45
62456	H-SAC-AP-1400	47	62512	HSA8CLL-S/S	47	62573	HV-2000-2SAC-CLL	43	62648	HV-1600-SAC-CLL-S/S	45
62456	H-SAC-AP-1400	48	62512	HSA8CLL-S/S	48	62574	HV-2200-2SAC-CM	43	62649	HV-1800-SAC-CM-S/S	45
62456	H-SAC-AP-1400	48	62512	HSA8CLL-S/S	51	62575	HV-2200-2SAC-CL	43	62650	HV-1800-SAC-CL-S/S	45
62456	H-SAC-AP-1400	48	62512	HSA8CLL-S/S	53	62576	HV-2200-2SAC-CLL	43	62651	HV-1800-SAC-CLL-S/S	45
62456	H-SAC-AP-1400	48	62512	HSA8CLL-S/S	54	62577	HV-2400-2SAC-CM	43	62652	H CARK-600-CS-S/S	46
62456	H-SAC-AP-1400	48	62513	HCSBB-60	55	62578	HV-2400-2SAC-CL	43	62653	H CARK-600-CM-S/S	46
62456	H-SAC-AP-1400	53	62513	HCSBB-60	55	62579	HV-2400-2SAC-CLL	43	62654	H CARK-600-CL-S/S	46

INDEX By Item Code

Item Code	Ordering Number	Page #	Item Code	Ordering Number	Page #	Item Code	Ordering Number	Page #	Item Code	Ordering Number	Page #
62655	H CARK-800-CS-S/S	46	62723	H-CARK2-2200-CL-S/S	46	62758	HCP-800-S/S	53	62848	EZP-LS230HT-S/S	10
62656	H CARK-800-CM-S/S	46	62724	H-CARK2-2200-CLL-S/S	46	62759	HCP-1000-S/S	57	62849	EZP-LS236HT-S/S	10
62657	H CARK-800-CL-S/S	46	62725	H-CARK2-2400-CM-S/S	46	62759	HCP-1000-S/S	43	62850	EZP-LS242HT-S/S	10
62658	H CARK-1000-CS-S/S	46	62726	H-CARK2-2400-CL-S/S	46	62760	HCP-1200-S/S	47	62851	EZP-LS248HT-S/S	10
62659	H CARK-1000-CM-S/S	46	62727	H-CARK2-2400-CLL-S/S	46	62760	HCP-1200-S/S	53	62852	EZP-LS254HT-S/S	10
62660	H CARK-1000-CL-S/S	46	62728	H-CARK2-2600-CM-S/S	46	62761	HCP-1400-S/S	47	62853	EZP-LS260HT-S/S	10
62661	H CARK-1200-CS-S/S	46	62729	H-CARK2-2600-CL-S/S	46	62761	HCP-1400-S/S	53	63020	MSTHD-G	68
62662	H CARK-1200-CM-S/S	46	62730	H-CARK2-2600-CLL-S/S	46	62762	HCP-1800-S/S	47	63024	CBD-ST-XL-S	146
62663	H CARK-1200-CL-S/S	46	62731	H-CARK2-2800-CM-S/S	46	62762	HCP-1800-S/S	53	63024	CBD-ST-XL-S	146
62664	H CARK-1400-CS-S/S	46	62732	H-CARK2-2800-CL-S/S	46	62763	H2CP-1200	48	63072	ATVK-73	69
62665	H CARK-1400-CM-S/S	46	62733	H-CARK2-2800-CLL-S/S	46	62763	H2CP-1200	54	63072	ATVK-73	74
62666	H CARK-1400-CL-S/S	46	62734	H-CARK2-3000-CM-S/S	46	62764	H2CP-1400	48	63072	ATVK-73	94
62667	H CARK-1600-CS-S/S	46	62735	H-CARK2-3000-CL-S/S	46	62764	H2CP-1400	54	63073	ATV-MOUNT	69
62668	H CARK-1600-CM-S/S	46	62736	H-CARK2-3000-CLL-S/S	46	62765	H2CP-1600	48	63073	ATV-MOUNT	74
62669	H CARK-1600-CL-S/S	46	62741	HCSTK-60-G	42	62765	H2CP-1600	54	63073	ATV-MOUNT	94
62670	H CARK-1800-CS-S/S	46	62741	H60CSK-G	55	62766	H2CP-1800	48	63079	H73BTK	47
62671	H CARK-1800-CM-S/S	46	62742	HCSTK-60-G-S/S	42	62766	H2CP-1800	54	63079	H73BTK	48
62672	H CARK-1800-CL-S/S	46	62742	H60CSK-G-S/S	55	62767	H2CP-2000	48	63079	H73BTK	53
62673	HV-1200-2SAC-CS-S/S	45	62743	H73CSK-G	42	62767	H2CP-2000	54	63079	H73BTK	54
62674	HV-1200-2SAC-CM-S/S	45	62743	H73CSK-G	47	62768	H2CP-2400	48	63080	H73BTK-S/S	47
62675	HV-1200-2SAC-CL-S/S	45	62743	H73CSK-G	48	62768	H2CP-2400	54	63080	H73BTK-S/S	48
62676	HV-1200-2SAC-CLL-S/S	45	62743	H73CSK-G	53	62769	H2CP-2600	48	63080	H73BTK-S/S	53
62677	HV-1400-2SAC-CS-S/S	45	62743	H73CSK-G	54	62769	H2CP-2600	54	63080	H73BTK-S/S	54
62678	HV-1400-2SAC-CM-S/S	45	62743	H73CSK-G	55	62770	H2CP-2800	48	63206	HV-600-SAC-CS-EL15	49
62679	HV-1400-2SAC-CL-S/S	45	62744	H73CSK-G-S/S	42	62770	H2CP-2800	54	63207	HV-600-SAC-CM-EL15	49
62680	HV-1400-2SAC-CLL-S/S	45	62744	H73CSK-G-S/S	47	62771	H2CP-3000	48	63208	HV-600-SAC-CL-EL15	49
62681	HV-1600-2SAC-CM-S/S	45	62744	H73CSK-G-S/S	48	62771	H2CP-3000	54	63209	HV-800-SAC-CS-EL15	49
62683	HV-1600-2SAC-CLL-S/S	45	62744	H73CSK-G-S/S	53	62801	H2CP-1200-S/S	48	63210	HV-800-SAC-CM-EL15	49
62684	HV-1800-2SAC-CM-S/S	45	62744	H73CSK-G-S/S	54	62801	H2CP-1200-S/S	54	63211	HV-800-SAC-CL-EL15	49
62685	HV-1800-2SAC-CL-S/S	45	62744	H73CSK-G-S/S	55	62802	H2CP-1400-S/S	48	63212	HV-1000-SAC-CS-EL15	49
62686	HV-1800-2SAC-CLL-S/S	45	62745	H73CSK-S	48	62802	H2CP-1400-S/S	54	63213	HV-1000-SAC-CM-EL15	49
62687	HV-2000-2SAC-CM-S/S	45	62745	H73CSK-S	54	62803	H2CP-1600-S/S	48	63214	HV-1000-SAC-CL-EL15	49
62688	HV-2000-2SAC-CL-S/S	45	62745	H73CSK-S	55	62803	H2CP-1600-S/S	54	63215	HV-1200-SAC-CS-EL15	49
62689	HV-2000-2SAC-CLL-S/S	45	62746	H73CSK-S-S/S	48	62804	H2CP-1800-S/S	48	63216	HV-1200-SAC-CM-EL15	49
62690	HV-2200-2SAC-CM-S/S	45	62746	H73CSK-S-S/S	54	62804	H2CP-1800-S/S	54	63217	HV-1200-SAC-CL-EL15	49
62691	HV-2200-2SAC-CL-S/S	45	62746	H73CSK-S-S/S	55	62805	H2CP-2000-S/S	48	63218	HV-1400-SAC-CS-EL15	49
62692	HV-2200-2SAC-CLL-S/S	45	62747	HCSTK-60-B	42	62805	H2CP-2000-S/S	54	63219	HV-1400-SAC-CM-EL15	49
62693	HV-2400-2SAC-CM-S/S	45	62747	H60CSK-B	55	62806	H2CP-2400-S/S	48	63220	HV-1400-SAC-CL-EL15	49
62694	HV-2400-2SAC-CL-S/S	45	62748	HCSTK-60-B-S/S	42	62806	H2CP-2400-S/S	54	63221	HV-1600-SAC-CM-EL15	49
62695	HV-2400-2SAC-CLL-S/S	45	62748	H60CSK-B-S/S	55	62807	H2CP-2600-S/S	48	63222	HV-1600-SAC-CL-EL15	49
62696	HV-2600-2SAC-CM-S/S	45	62749	H73CSK-B	42	62807	H2CP-2600-S/S	54	63223	HV-1600-SAC-CLL-EL15	49
62697	HV-2600-2SAC-CL-S/S	45	62749	H73CSK-B	47	62808	H2CP-2800-S/S	48	63224	HV-1800-SAC-CM-EL15	49
62698	HV-2600-2SAC-CLL-S/S	45	62749	H73CSK-B	48	62808	H2CP-2800-S/S	54	63225	HV-1800-SAC-CL-EL15	49
62699	HV-2800-2SAC-CM-S/S	45	62749	H73CSK-B	53	62809	H2CP-3000-S/S	48	63226	HV-1800-SAC-CLL-EL15	49
62700	HV-2800-2SAC-CL-S/S	45	62749	H73CSK-B	54	62809	H2CP-3000-S/S	54	63227	HV-600-SAC-CS-S/S-EL15	51
62701	HV-2800-2SAC-CLL-S/S	45	62749	H73CSK-B	55	62826	HTF212-S/S	15	63228	HV-600-SAC-CM-S/S-EL15	51
62702	HV-3000-2SAC-CM-S/S	45	62750	H73CSK-B-S/S	42	62827	HTF218-S/S	15	63229	HV-600-SAC-CL-S/S-EL15	51
62703	HV-3000-2SAC-CL-S/S	45	62750	H73CSK-B-S/S	47	62828	HTF224-S/S	15	63230	HV-800-SAC-CS-S/S-EL15	51
62704	HV-3000-2SAC-CLL-S/S	45	62750	H73CSK-B-S/S	48	62829	HTF230-S/S	15	63231	HV-800-SAC-CM-S/S-EL15	51
62705	H-CARK2-1200-CS-S/S	46	62750	H73CSK-B-S/S	53	62830	HTF236-S/S	15	63232	HV-800-SAC-CL-S/S-EL15	51
62706	H-CARK2-1200-CM-S/S	46	62750	H73CSK-B-S/S	54	62831	HTF242-S/S	15	63233	HV-1000-SAC-CS-S/S-EL15	51
62707	H-CARK2-1200-CL-S/S	46	62750	H73CSK-B-S/S	55	62832	HTF248-S/S	15	63234	HV-1000-SAC-CM-S/S-EL15	51
62708	H-CARK2-1200-CLL-S/S	46	62751	HCP-600	47	62833	HTF254-S/S	15	63235	HV-1000-SAC-CL-S/S-EL15	51
62709	H-CARK2-1400-CS-S/S	46	62751	HCP-600	53	62834	HTF260-S/S	15	63236	HV-1200-SAC-CS-S/S-EL15	51
62710	H-CARK2-1400-CM-S/S	46	62752	HCP-800	47	62835	HTF272-S/S	15	63237	HV-1200-SAC-CM-S/S-EL15	51
62711	H-CARK2-1400-CL-S/S	46	62752	HCP-800	53	62836	EZP-LS212-S/S	10	63238	HV-1200-SAC-CL-S/S-EL15	51
62712	H-CARK2-1400-CLL-S/S	46	62753	HCP-1000	47	62837	EZP-LS218-S/S	10	63239	HV-1400-SAC-CS-S/S-EL15	51
62713	H-CARK2-1600-CM-S/S	46	62753	HCP-1000	53	62838	EZP-LS224-S/S	10			
62714	H-CARK2-1600-CL-S/S	46	62754	HCP-1200	47	62839	EZP-LS230-S/S	10			
62715	H-CARK2-1600-CLL-S/S	46	62754	HCP-1200	53	62840	EZP-LS236-S/S	10			
62716	H-CARK2-1800-CM-S/S	46	62755	HCP-1400	47	62841	EZP-LS242-S/S	10			
62717	H-CARK2-1800-CL-S/S	46	62755	HCP-1400	53	62842	EZP-LS248-S/S	10			
62718	H-CARK2-1800-CLL-S/S	46	62756	HCP-1800	47	62843	EZP-LS254-S/S	10			
62719	H-CARK2-2000-CM-S/S	46	62756	HCP-1800	53	62844	EZP-LS260-S/S	10			
62720	H-CARK2-2000-CL-S/S	46	62757	HCP-600-S/S	47	62845	EZP-LS212HT-S/S	10			
62721	H-CARK2-2000-CLL-S/S	46	62757	HCP-600-S/S	53	62846	EZP-LS218HT-S/S	10			
62722	H-CARK2-2200-CM-S/S	46	62758	HCP-800-S/S	47	62847	EZP-LS224HT-S/S	10			

INDEX By Item Code

Item Code	Ordering Number	Page #	Item Code	Ordering Number	Page #	Item Code	Ordering Number	Page #	Item Code	Ordering Number	Page #
63240	HV-1400-SAC-CM-S/S-EL15	51	63464	HV-1800-2SAC-CM-S/S-EL15	51	63595	H-CARK2-2800-CLL-EL15	50	63637	H-CARK-1000-CS-EL15	50
63241	HV-1400-SAC-CL-S/S-EL15	51	63465	HV-1800-2SAC-CL-S/S-EL15	51	63596	H-CARK2-3000-CM-EL15	50	63638	H-CARK-1000-CM-EL15	50
63242	HV-1600-SAC-CM-S/S-EL15	51	63466	HV-1800-2SAC-CLL-S/S-EL15	51	63597	H-CARK2-3000-CL-EL15	50	63639	H-CARK-1000-CL-EL15	50
63243	HV-1600-SAC-CL-S/S-EL15	51	63467	HV-2000-2SAC-CM-S/S-EL15	51	63598	H-CARK2-3000-CLL-EL15	50	63640	H-CARK-1200-CS-EL15	50
63244	HV-1600-SAC-CLL-S/S-EL15	51	63468	HV-2000-2SAC-CL-S/S-EL15	51	63599	H-CARK2-1200-CS-S/S-EL15	52	63641	H-CARK-1200-CM-EL15	50
63245	HV-1800-SAC-CM-S/S-EL15	51	63469	HV-2000-2SAC-CLL-S/S-EL15	51	63600	H-CARK2-1200-CM-S/S-EL15	52	63642	H-CARK-1200-CL-EL15	50
63246	HV-1800-SAC-CL-S/S-EL15	51	63470	HV-2200-2SAC-CM-S/S-EL15	51	63601	H-CARK2-1200-CL-S/S-EL15	52	63643	H-CARK-1400-CS-EL15	50
63247	HV-1800-SAC-CLL-S/S-EL15	51	63471	HV-2200-2SAC-CL-S/S-EL15	51	63602	H-CARK2-1200-CLL-S/S-EL15	52	63644	H-CARK-1400-CM-EL15	50
63421	HV-1200-2SAC-CS-EL15	49	63472	HV-2200-2SAC-CLL-S/S-EL15	51	63603	H-CARK2-1400-CS-S/S-EL15	52	63645	H-CARK-1400-CL-EL15	50
63422	HV-1200-2SAC-CM-EL15	49	63473	HV-2400-2SAC-CM-S/S-EL15	51	63604	H-CARK2-1400-CM-S/S-EL15	52	63646	H-CARK-1600-CS-EL15	50
63423	HV-1200-2SAC-CL-EL15	49	63474	HV-2400-2SAC-CL-S/S-EL15	51	63605	H-CARK2-1400-CL-S/S-EL15	52	63647	H-CARK-1600-CM-EL15	50
63424	HV-1200-2SAC-CLL-EL15	49	63475	HV-2400-2SAC-CLL-S/S-EL15	51	63606	H-CARK2-1400-CLL-S/S-EL15	52	63648	H-CARK-1600-CL-EL15	50
63425	HV-1400-2SAC-CS-EL15	49	63476	HV-2600-2SAC-CM-S/S-EL15	51	63607	H-CARK2-1600-CM-S/S-EL15	52	63649	H-CARK-1800-CS-EL15	50
63426	HV-1400-2SAC-CM-EL15	49	63477	HV-2600-2SAC-CL-S/S-EL15	51	63608	H-CARK2-1600-CL-S/S-EL15	52	63650	H-CARK-1800-CM-EL15	50
63427	HV-1400-2SAC-CL-EL15	49	63478	HV-2600-2SAC-CLL-S/S-EL15	51	63609	H-CARK2-1600-CLL-S/S-EL15	52	63651	H-CARK-1800-CL-EL15	50
63428	HV-1400-2SAC-CLL-EL15	49	63479	HV-2800-2SAC-CM-S/S-EL15	51	63610	H-CARK2-1800-CM-S/S-EL15	52	63652	H CARK-600-CS-S/S-EL15	52
63429	HV-1600-2SAC-CM-EL15	49	63480	HV-2800-2SAC-CL-S/S-EL15	51	63611	H-CARK2-1800-CL-S/S-EL15	52	63653	H CARK-600-CM-S/S-EL15	52
63430	HV-1600-2SAC-CL-EL15	49	63481	HV-2800-2SAC-CLL-S/S-EL15	51	63612	H-CARK2-1800-CLL-S/S-EL15	52	63654	H CARK-600-CL-S/S-EL15	52
63431	HV-1600-2SAC-CLL-EL15	49	63482	HV-3000-2SAC-CM-S/S-EL15	51	63613	H-CARK2-2000-CM-S/S-EL15	52	63655	H CARK-800-CS-S/S-EL15	52
63432	HV-1800-2SAC-CM-EL15	49	63483	HV-3000-2SAC-CL-S/S-EL15	51	63614	H-CARK2-2000-CL-S/S-EL15	52	63656	H CARK-800-CM-S/S-EL15	52
63433	HV-1800-2SAC-CL-EL15	49	63484	HV-3000-2SAC-CLL-S/S-EL15	51	63615	H-CARK2-2000-CLL-S/S-EL15	52	63657	H CARK-800-CL-S/S-EL15	52
63434	HV-1800-2SAC-CLL-EL15	49	63554	CBD-XXL-S/S	145	63616	H-CARK2-2200-CM-S/S-EL15	52	63658	H CARK-1000-CS-S/S-EL15	52
63435	HV-2000-2SAC-CM-EL15	49	63556	HVT8-EL15-S/S	54	63617	H-CARK2-2200-CL-S/S-EL15	52	63659	H CARK-1000-CM-S/S-EL15	52
63436	HV-2000-2SAC-CL-EL15	49	63567	H-CARK2-1200-CS-EL15	50	63618	H-CARK2-2200-CLL-S/S-EL15	52	63660	H CARK-1000-CL-S/S-EL15	52
63437	HV-2000-2SAC-CLL-EL15	49	63568	H-CARK2-1200-CM-EL15	50	63619	H-CARK2-2400-CM-S/S-EL15	52	63661	H CARK-1200-CS-S/S-EL15	52
63438	HV-2200-2SAC-CM-EL15	49	63569	H-CARK2-1200-CL-EL15	50	63620	H-CARK2-2400-CL-S/S-EL15	52	63662	H CARK-1200-CM-S/S-EL15	52
63439	HV-2200-2SAC-CL-EL15	49	63570	H-CARK2-1200-CLL-EL15	50	63621	H-CARK2-2400-CLL-S/S-EL15	52	63663	H CARK-1200-CL-S/S-EL15	52
63440	HV-2200-2SAC-CLL-EL15	49	63571	H-CARK2-1400-CS-EL15	50	63622	H-CARK2-2600-CM-S/S-EL15	52	63664	H CARK-1400-CS-S/S-EL15	52
63441	HV-2400-2SAC-CM-EL15	49	63572	H-CARK2-1400-CM-EL15	50	63623	H-CARK2-2600-CL-S/S-EL15	52	63665	H CARK-1400-CM-S/S-EL15	52
63442	HV-2400-2SAC-CL-EL15	49	63573	H-CARK2-1400-CL-EL15	50	63624	H-CARK2-2600-CLL-S/S-EL15	52	63666	H CARK-1400-CL-S/S-EL15	52
63443	HV-2400-2SAC-CLL-EL15	49	63574	H-CARK2-1400-CLL-EL15	50	63625	H-CARK2-2800-CM-S/S-EL15	52	63667	H CARK-1600-CS-S/S-EL15	52
63444	HV-2600-2SAC-CM-EL15	49	63575	H-CARK2-1600-CM-EL15	50	63626	H-CARK2-2800-CL-S/S-EL15	52	63668	H CARK-1600-CM-S/S-EL15	52
63445	HV-2600-2SAC-CL-EL15	49	63576	H-CARK2-1600-CL-EL15	50	63627	H-CARK2-2800-CLL-S/S-EL15	52	63669	H CARK-1600-CL-S/S-EL15	52
63446	HV-2600-2SAC-CLL-EL15	49	63577	H-CARK2-1600-CLL-EL15	50	63628	H-CARK2-3000-CM-S/S-EL15	52	63670	H CARK-1800-CS-S/S-EL15	52
63447	HV-2800-2SAC-CM-EL15	49	63578	H-CARK2-1800-CM-EL15	50	63629	H-CARK2-3000-CL-S/S-EL15	52	63671	H CARK-1800-CM-S/S-EL15	52
63448	HV-2800-2SAC-CL-EL15	49	63579	H-CARK2-1800-CL-EL15	50	63630	H-CARK2-3000-CLL-S/S-EL15	52	63672	H CARK-1800-CL-S/S-EL15	52
63449	HV-2800-2SAC-CLL-EL15	49	63580	H-CARK2-1800-CLL-EL15	50	63631	H-CARK-600-CS-EL15	50	63673	HDRP27	123
63450	HV-3000-2SAC-CM-EL15	49	63582	H-CARK2-2000-CL-EL15	50	63632	H-CARK-600-CM-EL15	50	63674	HDRP17	123
63451	HV-3000-2SAC-CL-EL15	49	63583	H-CARK2-2000-CLL-EL15	50	63633	H-CARK-600-CL-EL15	50	63747	CBD-ST-XXL	146
63452	HV-3000-2SAC-CLL-EL15	49	63584	H-CARK2-2200-CM-EL15	50	63634	H-CARK-800-CS-EL15	50	63748	CBD-ST-XXL-S/S	146
63453	HV-1200-2SAC-CS-S/S-EL15	51	63585	H-CARK2-2200-CL-EL15	50	63635	H-CARK-800-CM-EL15	50	63749	CBD-ST-XXL-MF	146
63454	HV-1200-2SAC-CM-S/S-EL15	51	63586	H-CARK2-2200-CLL-EL15	50	63636	H-CARK-800-CL-EL15	50	63750	CBD-ST-XXL-MF-S/S	146
63455	HV-1200-2SAC-CL-S/S-EL15	51	63587	H-CARK2-2400-CM-EL15	50	63637	H-CARK-800-CL-EL15	50	63751	CBD-ST-XXL-FP	146
63456	HV-1200-2SAC-CLL-S/S-EL15	51	63588	H-CARK2-2400-CL-EL15	50	63638	H-CARK-800-CM-EL15	50	63752	CBD-ST-XXL-FP	146
63457	HV-1400-2SAC-CS-S/S-EL15	51	63589	H-CARK2-2400-CLL-EL15	50	63639	H-CARK-800-CS-EL15	50	63752	CBD-ST-XXL-B	146
63458	HV-1400-2SAC-CM-S/S-EL15	51	63590	H-CARK2-2600-CM-EL15	50	63640	H-CARK-800-CM-EL15	50	63752	CBD-ST-XXL-B	146
63459	HV-1400-2SAC-CL-S/S-EL15	51	63591	H-CARK2-2600-CL-EL15	50	63641	H-CARK-800-CM-EL15	50	63791	CBD-ST-XXL-S	146
63460	HV-1400-2SAC-CLL-S/S-EL15	51	63592	H-CARK2-2600-CLL-EL15	50	63642	H-CARK-800-CM-EL15	50	63791	CBD-ST-XXL-S	146
63461	HV-1600-2SAC-CM-S/S-EL15	51	63593	H-CARK2-2800-CM-EL15	50	63643	H-CARK-800-CM-EL15	50	63861	HATDMK-S/S	55
63462	HV-1600-2SAC-CL-S/S-EL15	51	63594	H-CARK2-2800-CL-EL15	50	63644	H-CARK-800-CM-EL15	50	63862	HDATDMK-S/S	55
63463	HV-1600-2SAC-CLL-S/S-EL15	51							63936	HV450SS-PCST	40
									63937	HV450S-PCST	40
									63938	HV450M-PCST	40
									63939	HV600SS-PCST	40
									63940	HV600S-PCST	40
									63941	HV600M-PCST	40
									63942	HV750SS-PCST	40
									63943	HV750S-PCST	40
									63944	HV750M-PCST	40
									63945	HV900SS-PCST	40
									63946	HV900S-PCST	40
									63947	HV900M-PCST	40
									63948	HV900L-PCST	40
									63950	HV1050S-PCST	40
									63951	HV1050M-PCST	40
									63952	HV1050L-PCST	40
									63953	HV1200SS-PCST	40



INDEX By Item Code

Item Code	Ordering Number	Page #	Item Code	Ordering Number	Page #	Item Code	Ordering Number	Page #	Item Code	Ordering Number	Page #
63954	HV1200S-PCST	40	64021	MHS-750-MST	67	72484	CBR-M	145	73114	BP1500	140
63955	HV1200M-PCST	40	64022	MHS-900-MST	67	72485	CBR-L	145	73115	BP1600	140
63956	HV1200L-PCST	40	64023	MHS-1050-MST	67	72486	CBR-XL	145	73117	BP1800	140
63957	HV1500M-PCST	40	64024	MHS-1200-MST	67	73003	PP450	64	73118	BP1200-1400-PL	140
63958	HV1500L-PCST	40	64025	MHS-1350-MST	67	73004	PV600	63	73119	BP1500-1600-PL	140
63959	HV1500LL-PCST	40	64026	MHS-1500-MST	67	73005	PP600	64	73121	BP1800-PL	140
63960	HV1600M-PCST	40	64027	MHS-1800-MST	67	73006	PV750	63	73123	BP-MB	140
63961	HV1600L-PCST	40	64028	MHS-2100-MST	67	73007	PP750	64	73125	BP-SC	140
63962	HV1600LL-PCST	40	64029	MHS-2400-MST	67	73008	PP900	63	73127	BP-LA	140
63963	HV1800M-PCST	40	64030	MHS-600-MST-S/S	67	73009	PP900	64	73138	BP-TB	140
63964	HV1800L-PCST	40	64031	MHS-750-MST-S/S	67	73010	PV1050	63	73139	BP-UB	140
63965	HV1800LL-PCST	40	64032	MHS-900-MST-S/S	67	73011	PP1050	64	73141	BP-TL	140
63966	HV2100M-PCST	40	64033	MHS-1050-MST-S/S	67	73012	PV1200	63	73156	PSA150	64
63967	HV2100L-PCST	40	64034	MHS-1200-MST-S/S	67	73013	PP1200	64	73156	PSA150	66
63968	HV2100LL-PCST	40	64035	MHS-1350-MST-S/S	67	73014	PS600	119	73156	PSA150 (V-Tip)	77
63969	HV2400M-PCST	40	64036	MHS-1500-MST-S/S	67	73015	PP1400	64	73156	PSA150	80
63970	HV2400L-PCST	40	64037	MHS-1800-MST-S/S	67	73016	PP1500	64	73158	HV1500L	38
63971	HV2400LL-PCST	40	64038	MHS-2100-MST-S/S	67	73019	HV450M	38	73160	PIHMK	62
63972	HV2600M-PCST	40	64039	MHS-2400-MST-S/S	67	73020	PU150	64	73162	RBPCP	148
63973	HV2600L-PCST	40	64045	HV1050SS-PCST	40	73024	PPS6	64	73163	RBPRET	152
63974	HV2600LL-PCST	40	64175	AIR HARK-S/S-73	55	73025	P/RMK	61	73173	HV600M	38
63975	HV3000M-PCST	40	64178	CBD-S-S/S	145	73026	HV450SS	38	73174	HV750M	38
63976	HV3000L-PCST	40	64310	CBD-ST-BB	146	73027	HP450	42	73175	HV900M	38
63977	HV3000LL-PCST	40	64310	CBD-ST-BB	146	73028	HV450S	38	73177	HV1500M	38
63978	HV450SS-PCST-S/S	41	64482	CBD-ST-XL-B-P	146	73029	HP600	42	73178	HV900L	38
63979	HV450S-PCST-S/S	41	64482	CBD-ST-XL-B-P	146	73030	HV600S	38	73179	HV1050L	38
63980	HV450M-PCST-S/S	41	64620	CBD-ST-B-P	146	73031	HP750	42	73180	HV1200L	38
63981	HV600SS-PCST-S/S	41	64620	CBD-ST-B-P	146	73032	HV750S	38	73215	HV1500LL	38
63982	HV600S-PCST-S/S	41	64621	CBD-ST-L-B-P	146	73033	HP900	42	73221	PSSS-N	119
63983	HV600M-PCST-S/S	41	64621	CBD-ST-L-B-P	146	73034	HV900S	38	73222	PSSS-H	119
63984	HV750SS-PCST-S/S	41	64622	CBD-ST-XXL-B-P	146	73035	HP1050	42	73235	CCKHDTSS-S/S	64
63985	HV750S-PCST-S/S	41	64622	CBD-ST-XXL-B-P	146	73036	HV1050M	38	73235	CCKHDTSS-S/S	66
63986	HV750M-PCST-S/S	41	64623	CBD-ST-M-P-S/S	146	73037	HP1200	42	73235	CCKHDTSS-S/S	71
63987	HV900SS-PCST-S/S	41	64624	CBD-ST-L-P-S/S	146	73038	HV1200M	38	73301	BP1200-HD-B	140
63988	HV900S-PCST-S/S	41	64625	CBD-ST-XL-P-S/S	146	73045	HV600SS	38	73302	BP1400-HD-B	140
63989	HV900M-PCST-S/S	41	64626	CBD-ST-XXL-P-S/S	146	73047	HSA8SS	38	73303	BP1500-HD-B	140
63990	HV900L-PCST-S/S	41	64772	CBD-ST-M-P	146	73047	HSA8SS	40	73304	BP1600-HD-B	140
63991	HV1050SS-PCST-S/S	41	64773	CBD-ST-L-P	146	73048	HSA8S	38	73306	BP1800-HD-B	140
63992	HV1050S-PCST-S/S	41	64774	CBD-ST-L-P	146	73048	HSA8S	40	73307	BP2000-HD-B	140
63993	HV1050M-PCST-S/S	41	64775	CBD-ST-XXL-P	146	73049	HSA8M	38	73308	BP2200-HD-B	140
63994	HV1050L-PCST-S/S	41	64776	CBD-ST-M-PSS	146	73049	HSA8M	40	73309	BP2400-HD-B	140
63995	HV1200SS-PCST-S/S	41	64777	CBD-ST-L-PS	146	73050	HP58	42	73311	BP2500-HD-B	140
63996	HV1200S-PCST-S/S	41	64778	CBD-ST-XL-PS	146	73053	HV750SS	38	73433	PHSC-S/S	64
63997	HV1200M-PCST-S/S	41	64779	CBD-ST-XXL-PS	146	73054	HMK	42	73433	PHSC-S/S	82
63998	HV1200L-PCST-S/S	41	64780	CBD-ST-M-PS-S/S	146	73055	HV900SS	38	73433	PHSC-S/S	119
63999	HV1500M-PCST-S/S	41	64781	CBD-ST-L-PS-S/S	146	73056	HV1050S	38	73434	PSVA	119
64000	HV1500L-PCST-S/S	41	64782	CBD-ST-XL-PS-S/S	146	73057	HV1050SS	38	73435	PV450	63
64001	HV1500LL-PCST-S/S	41	64783	CBD-ST-XXL-PS-S/S	146	73058	HV1200S	38	73436	PV1400	63
64002	HV1600M-PCST-S/S	41	64784	CBD-ST-M-S	146	73059	HV1200SS	38	73437	PV1500	63
64003	HV1600L-PCST-S/S	41	64784	CBD-ST-M-S	146	73063	HSA8L	38	73443	HXF1600M	36
64004	HV1600LL-PCST-S/S	41	64785	CBD-ST-L-S	146	73063	HSA8L	40	73444	HXF1600L	36
64005	HV1800M-PCST-S/S	41	64785	CBD-ST-L-S	146	73064	HSA8LL	38	73483	HSKD	42
64006	HV1800L-PCST-S/S	41	64787	CBD-XXL	145	73064	HSA8LL	40	73483	HSKD	47
64007	HV1800LL-PCST-S/S	41	64924	MSR-S/S	159	73066	HP1500	42	73483	HSKD	48
64008	HV2100M-PCST-S/S	41	64925	PMSMK-S/S	159	73068	HBRK	42	73483	HSKD	53
64009	HV2100L-PCST-S/S	41	64926	MAK-S/S	159	73069	HARK	42	73483	HSKD	54
64010	HV2100LL-PCST-S/S	41	64930	MSTLP	68	73069	HARK	107	73486	HSA	42
64011	HV2400M-PCST-S/S	41	64930	MSTLP	68	73102	BP450	140	73489	HSA200	38
64012	HV2400L-PCST-S/S	41	64931	MSTAM-S/S	68	73104	BP600	140	73489	HSA200	40
64013	HV2400LL-PCST-S/S	41	71053	FLSC2000	160	73106	BP750	140	73489	HSA200	42
64014	HV2600M-PCST-S/S	41	71056	FLSC-TP	160	73107	BP800	140	73489	HSA200	43
64015	HV2600L-PCST-S/S	41	71057	FLSC-CP	160	73108	BP900	140	73489	HSA200	47
64016	HV2600LL-PCST-S/S	41	71059	FLSC2000-MC	160	73109	BP450-750-PL	140	73489	HSA200	48
64017	HV3000M-PCST-S/S	41	71061	FLSC2000-CB	160	73110	BP1050	140	73489	HSA200	49
64018	HV3000L-PCST-S/S	41	71140	FLSCM-CP	160	73111	BP800-1050-PL	140	73489	HSA200	53
64019	HV3000LL-PCST-S/S	41	71148	FLSCM2000	160	73112	BP1200	140	73489	HSA200	54
64020	MHS-600-MST	67	72483	CBR-S	145	73113	BP1400	140	73494	HVC-S/S	42

INDEX By Item Code

Item Code	Ordering Number	Page #	Item Code	Ordering Number	Page #	Item Code	Ordering Number	Page #	Item Code	Ordering Number	Page #
73537	PS1800	119	74049	PS1800PL*	119	74563	RBPSR-M	148	74918	MAK	159
73539	PS2000	119	74050	PS2000 PL*	119	74564	RBPSR-L	148	74919	MAKHD	159
73541	PS750	119	74053	PSN11010	119	74565	RBPSR-XL	148	74919	MAKHD	159
73542	PS900	119	74055	BP450-B	140	74582	HDMRK	42	74921	MORK	159
73543	PS1050	119	74057	BP800-B	140	74582	HDMRK	42	74921	MORK	159
73544	PS1200	119	74100	HW-BC	123	74597	PPHD1800	64	74923	MCRK	159
73545	PS1500	119	74141	HTTS	123	74598	PVHD1800	63	74923	MCRK	159
73546	PS1400	119	74307	HXF8SS	36	74601	HPHD1800	42	74925	MCB	159
73582	PS600PL*	119	74307	HXF8SS	37	74602	HVHD1800M	38	74925	MCB	159
73583	PS750PL*	119	74327	RBPMBK	148	74604	RP450	66	74927	MCSK	159
73584	PS900PL*	119	74417	STJK	42	74605	RP600	66	74927	MCSK	159
73585	PS1050PL*	119	74417	STJK	42	74606	RP750	66	74928	MCSKHD	159
73586	PS1200PL*	119	74417	STJK-S/S	107	74607	RP900	66	74928	MCSKHD	159
73587	PS1400PL*	119	74417	STJK-S/S	108	74608	RP1050	66	74930	MCS	159
73588	PS1500PL*	119	74419	STTS	42	74609	RP1200	66	74930	MCS	159
73626	PHA	64	74419	STTS	107	74610	RP1400	66	74931	MCSHD	159
73626	PHA	80	74420	UTS	42	74611	RP1500	66	74931	MCSHD	159
73628	RSA150	66	74448	UFB18	109	74613	RPHD1800	66	74941	SRBK	123
73628	RSA150	68	74449	UFB24	109	74614	RPHD2000	66	75266	HXF450S-S/S	37
73628	RSA150	71	74450	UFB30	109	74615	RPHD2400	66	75267	HXF450M-S/S	37
73628	RSA150	73	74451	UFB36	109	74633	RV450	65	75268	HXF600S-S/S	37
73628	RSA150 (V-Tip)	84	74452	UFB42	109	74634	RV600	65	75269	HXF600M-S/S	37
73628	RSA150	87	74453	UFB48	109	74635	RV750	65	75270	HXF750S-S/S	37
73628	RSA150 (V-Tip)	91	74454	UFB54	109	74636	RV900	65	75271	HXF750M-S/S	37
73628	RSA150	93	74455	UFB60	109	74637	RV1050	65	75272	HXF900S-S/S	37
73628	RSA150 (V-Tip)	98	74456	UFB72	109	74638	RV1200	65	75273	HXF900M-S/S	37
73628	RSA150	100	74460	UFB84	109	74639	RV1400	65	75274	HXF900L-S/S	37
73631	HVPT-S/S	38	74477	HVHD1800L	38	74640	RV1500	65	75275	HXF1050S-S/S	37
73631	HVPT-S/S	39	74478	HVHD1800LL	38	74642	RVHD1800	65	75276	HXF1050M-S/S	37
73631	HVPT-S/S	40	74490	HDCK	42	74643	RVHD2100	65	75277	HXF1050L-S/S	37
73631	HVPT-S/S	41	74490	HBP-SC-TP	142	74644	RVHD2400	65	75278	HXF1200S-S/S	37
73631	HVPT-S/S	42	74502	HDT5	107	74659	HXF450S	36	75279	HXF1200M-S/S	37
73631	HVPT-S/S	45	74504	STKD	42	74660	HXF450M	36	75280	HXF1200L-S/S	37
73631	HVPT-S/S	47	74506	STCK	42	74661	HXF600S	36	75281	HXF1500M-S/S	37
73631	HVPT-S/S	48	74535	CT6	64	74662	HXF600M	36	75282	HXF1500L-S/S	37
73631	HVPT-S/S	51	74535	CT6	66	74663	HXF750S	36	75283	HXF1600M-S/S	37
73631	HVPT-S/S	53	74535	CT6	68	74664	HXF750M	36	75284	HXF1600L-S/S	37
73631	HVPT-S/S	54	74535	CT6	71	74665	HXF900S	36	75293	HV450SS-S/S	39
73637	HV1600M	38	74535	CT6	73	74666	HXF900M	36	75294	HV450S-S/S	39
73638	HV1600L	38	74535	CT6 (C-Tip)	77	74667	HXF900L	36	75295	HV450M-S/S	39
73639	HV1600LL	38	74535	CT6	80	74668	HXF1050S	36	75296	HV600SS-S/S	39
73739	HP1600	42	74535	CT6	82	74669	HXF1050M	36	75297	HV600S-S/S	39
73771	HSA8SS-S/S	39	74535	CT6 (C-Tip)	84	74670	HXF1050L	36	75298	HV600M-S/S	39
73771	HSA8SS-S/S	41	74535	CT6	87	74671	HXF1200S	36	75299	HV750SS-S/S	39
73772	HSA8S-S/S	39	74535	CT6	89	74672	HXF1200M	36	75300	HV750S-S/S	39
73772	HSA8S-S/S	41	74535	CT6 (C-Tip)	91	74673	HXF1200L	36	75301	HV750M-S/S	39
73773	HSA8M-S/S	39	74535	CT6	93	74677	HXF1500M	36	75302	HV900SS-S/S	39
73773	HSA8M-S/S	41	74535	CT6	96	74678	HXF1500L	36	75303	HV900S-S/S	39
73774	HSA8L-S/S	39	74539	HVHD2100M	38	74681	HXFHD1800M	36	75304	HV900M-S/S	39
73774	HSA8L-S/S	41	74540	HVHD2100L	38	74682	HXFHD1800L	36	75305	HV900L-S/S	39
73777	BP600-B	140	74541	HVHD2100LL	38	74683	HXFHD2100M	36	75306	HV1050SS-S/S	39
73778	BP750-B	140	74544	HVHD2400M	38	74684	HXFHD2100L	36	75307	HV1050S-S/S	39
73779	BP900-B	140	74545	HVHD2400L	38	74685	HXFHD2400M	36	75308	HV1050M-S/S	39
73780	BP1050-B	140	74547	HPHD2000	42	74686	HXFHD2400L	36	75309	HV1050L-S/S	39
73781	BP1200-B	140	74548	HPHD2400	42	74689	HXF8S	36	75310	HV1200SS-S/S	39
73782	BP1400-B	140	74549	HBRKX	42	74689	HXF8S	37	75311	HV1200S-S/S	39
73783	BP1500-B	140	74550	HDARK	42	74690	HXF8M	36	75312	HV1200M-S/S	39
73784	BP1600-B	140	74551	HDMK	42	74690	HXF8M	37	75313	HV1200L-S/S	39
73785	BP1800-B	140	74553	PVHD2100	63	74691	HXF8L	36	75314	HV1500M-S/S	39
73922	HBP-MB-TP	142	74555	PVHD2400	63	74691	HXF8L	37	75315	HV1500L-S/S	39
73922	HBP-MB-TP	144	74556	PPHD2000	64	74773	PSSS	64	75316	HV1500LL-S/S	39
73946	RBPFK-S	148	74557	PPHD2400	64	74775	STJM	42	75317	HV1600M-S/S	39
73947	RBPFK-M	148	74558	PSR-S	147	74775	STJM	42	75318	HV1600L-S/S	39
73948	RBPFK-L	148	74559	PSR-M	147	74775	STJM	107	75319	HV1600LL-S/S	39
73949	RBPFK-XL	148	74560	PSR-L	147	74914	MSR	157	75323	PV450-S/S	63
74033	HSA8LL-S/S	39	74561	PSR-XL	147	74914	MSR	159	75324	PV600-S/S	63
74033	HSA8LL-S/S	41	74562	RBPSR-S	148	74916	PMSMK	159	75325	PV750-S/S	63

INDEX By Item Code

Item Code	Ordering Number	Page #	Item Code	Ordering Number	Page #	Item Code	Ordering Number	Page #	Item Code	Ordering Number	Page #
75326	PV900-S/S	63	75513	PAB	80	75625	EZP1P48	21	75906	AWTMB	32
75327	PV1050-S/S	63	75513	PAB	87	75626	EZP1P54	17	75907	AWTA	26
75328	PV1200-S/S	63	75513	PAB	100	75626	EZP1P54	21	75907	AWTA	32
75329	PV1400-S/S	63	75513	PAB-S/S	64	75627	EZP1P60	17	75908	AWTCB	26
75330	PV1500-S/S	63	75515	PAB-S/S	66	75627	EZP1P60	21	75908	AWTCB	32
75341	RV450-S/S	65	75515	PAB-S/S	71	75629	CRB16	19	75909	AWTHK	26
75342	RV600-S/S	65	75516	PMBL (left)	61	75630	CRB22	19	75909	AWTHK	32
75343	RV750-S/S	65	75516	PMBL (left)	62	75631	CRB28	19	75929	MHCP-24S	30
75344	RV900-S/S	65	75516	PMBL (left)	66	75632	CRB34	19	75930	MHCP-30S	30
75345	RV1050-S/S	65	75516	PMBL (left)	71	75633	CRB40	19	75931	MHCP-36S	30
75346	RV1200-S/S	65	75516	PMBL	80	75634	CRB46	19	75932	MHCP-42S	30
75347	RV1400-S/S	65	75516	PMBL	87	75635	CRB52	19	75933	MHCP-48S	30
75348	RV1500-S/S	65	75516	PMBL	100	75636	CRB58	19	75934	MHCP-54S	30
75373	HP450-S/S	42	75516	PMBL	114	75637	EZP1MPK	17	75935	MHCP-60S	30
75374	HP600-S/S	42	75518	PMBL-S/S (left)	64	75641	EZP1PL	17	75936	MHCP-72S	30
75375	HP750-S/S	42	75518	PMBL-S/S (left)	66	75641	EZP1PL	21	75937	MHCP-24A	30
75376	HP900-S/S	42	75518	PMBL-S/S (left)	69	75642	EZP1BP	17	75938	MHCP-30A	30
75377	HP1050-S/S	42	75518	PMBL-S/S (left)	71	75642	EZP1BP	21	75939	MHCP-36A	30
75378	HP1200-S/S	42	75518	PMBL-S/S	74	75771	EZP1-272	15	75940	MHCP-42A	30
75379	HP1500-S/S	42	75518	PMBL-S/S	82	75772	EZP1P72	17	75941	MHCP-48A	30
75380	HP1600-S/S	42	75518	PMBL-S/S	89	75772	EZP1P72	21	75942	MHCP-54A	30
75382	PP450-S/S	64	75518	PMBL-S/S	94	75773	CRB70	19	75943	MHCP-60A	30
75383	PP600-S/S	64	75518	PMBL-S/S	102	75775	CRB64	19	75944	MHCP-72A	30
75384	PP750-S/S	64	75519	PMBR (right)	61	75811	MSPMPK	25	75961	MHP-CP600	32
75385	PP900-S/S	64	75519	PMBR (right)	62	75830	MMBK	124	75962	MHP-CP750	32
75386	PP1050-S/S	64	75519	PMBL (right)	64	75843	STS-S	62	75963	MHP-CP900	32
75387	PP1200-S/S	64	75519	PMBL (right)	66	75843	STS-S	68	75964	MHP-CP1050	32
75388	PP1400-S/S	64	75519	PMBL (right)	71	75843	STS-S	73	75965	MHP-CP1200	32
75389	PP1500-S/S	64	75519	PMBR	80	75843	STS-S	94	75966	MHP-CP1400	32
75400	RP450-S/S	66	75519	PMBR	87	75844	STS-B	55	75967	MHP-CP1500	32
75401	RP600-S/S	66	75519	PMBR	100	75844	STS-B	55	75968	MHP-CP1800	32
75402	RP750-S/S	66	75519	PMBR	114	75844	STS-B	52	75978	SSRB	32
75403	RP900-S/S	66	75521	PMBL-S/S (right)	64	75844	STS-B	62	75978	SSRB	35
75404	RP1050-S/S	66	75521	PMBL-S/S (right)	66	75844	STS-B	68	75979	HXF2-SS	36
75405	RP1200-S/S	66	75521	PMBR-S/S	69	75844	STS-B	73	75979	HXF2-SS	37
75406	RP1400-S/S	66	75521	PMBL-S/S (right)	71	75844	STS-B	94	75980	HXF2-S	36
75407	RP1500-S/S	66	75521	PMBR-S/S	74	75845	QMTS-P	17	75980	HXF2-S	37
75419	HVT8-S/S	39	75521	PMBR-S/S	82	75845	QMTS-P	25	75981	HXF2-S	36
75419	HVT8-S/S	41	75521	PMBR-S/S	89	75845	QMTS-P	107	75981	HXF2-M	37
75419	HVT8-S/S	42	75521	PMBR-S/S	94	75846	STS-W	68	75981	HXF2-M	37
75419	HVT8-S/S	45	75521	PMBR-S/S	102	75846	STS-W	73	75982	HXF2-L	36
75419	HVT8-S/S	47	75531	MFASK	159	75846	STS-W	94	75982	HXF2-L	37
75419	HVT8-S/S	48	75531	MFASK	159	75847	STAK	73	76024	MAPEK	124
75419	HVT8-S/S	48	75565	HSA8SSS	39	75847	STAK	73	76025	MCBK	159
75419	HVT8-S/S	51	75565	HSA8SSS	41	75847	STAK	94	76025	MCBK	159
75419	HVT8-S/S	53	75585	STTS-S/S	108	75847	STAK	96	76026	MCBKHD	159
75419	HVT8-S/S	54	75586	HDTs-S/S	108	75892	STAKHD	73	76026	MCBKHD	159
75420	PVT6-S/S	64	75611	EZP1-218	15	75892	STAKHD	73	76027	HSA200-EL15	49
75420	PVT6-S/S	66	75612	EZP1-224	15	75892	STAKHD	94	76027	HSA200-EL15	53
75420	PVT6-S/S	82	75613	EZP1-230	15	75892	STAKHD	96	76027	HSA200-EL15	54
75420	PVT6-S/S	119	75614	EZP1-236	15	75893	PST-W	32	76069	AWTNCB	26
75422	HBRK-S/S	42	75615	EZP1-242	15	75894	PST-S	32	76069	AWTNCB	32
75422	HBRK-S/S-60	55	75616	EZP1-248	15	75895	PMB	32	76071	SSTSMB	124
75423	HARK-S/S	42	75617	EZP1-254	15	75896	PSTA	25	76072	SSTLMB	124
75424	HMK-S/S	42	75618	EZP1-260	15	75896	PSTA	32	76073	SSTOTA	124
75425	STCK-S/S	42	75619	EZP1P12	17	75897	PTPK	32	76074	QMT-P	25
75426	STJM-S/S	42	75619	EZP1P12	21	75898	PSTS-W	25	76075	QMT-W	25
75427	STJM-S/S	42	75620	EZP1P18	17	75898	PSTS-W	32	76075	QMT-W	25
75427	STKD-S/S	42	75620	EZP1P18	21	75898	PSTS-W	35	76096	QMTPAK	25
75452	PVHD2000	63	75621	EZP1P24	17	75898	PSTS-W	107	76097	QMTBK-P	25
75463	RVHD2000	65	75621	EZP1P24	17	75898	PSTS-W	107	76097	QMTBK-P	27
75507	PCB	61	75622	EZP1P30	17	75899	PSTS-S	32	76098	QMTBK-W	25
75510	PHDCB	62	75622	EZP1P30	17	75899	PSTS-S	35	76098	QMTBK-W	27
75513	PAB	61	75622	EZP1P30	21	75899	PSTS-S	55	76098	QMTBK-W	32
75513	PAB	62	75623	EZP1P36	17	75904	AWT	26	76098	QMTBK-W	35
75513	PAB	64	75623	EZP1P36	21	75904	AWT	32	76099	QMTPSBK	25
75513	PAB	66	75624	EZP1P42	17	75905	AWTB	26	76205	RVT6-S/S	66
75513	PAB	71	75624	EZP1P42	21	75905	AWTB	32	76205	RVT6-S/S	68
			75625	EZP1P48	17	75906	AWTMB	26	76205	RVT6-S/S	71

INDEX By Item Code

Item Code	Ordering Number	Page #	Item Code	Ordering Number	Page #	Item Code	Ordering Number	Page #	Item Code	Ordering Number	Page #
76205	RVT6-S/S	73	76456	MMP-660	23	76598	CRB-HT40	19	76737	URVB24/600	106
76205	RVT6-S/S	89	76457	MMP-672	23	76599	CRB-HT46	19	76737	URVB24/600	106
76205	RVT6-S/S	96	76458	MMPCP24	25	76600	CRB-HT52	19	76737	URVB24/600	109
76205	RVT6-S/S	102	76459	MMPCP30	25	76601	CRB-HT58	19	76738	URVB30/750	105
76245	HDMRK-S/S	42	76460	MMPCP36	25	76602	CRB-HT64	19	76738	URVB30/750	105
76245	HDMRK-S/S	42	76461	MMPCP42	25	76603	CRB-HT70	19	76738	URVB30/750	106
76246	HBRKX-S/S	42	76462	MMPCP48	25	76636	SSTBK-W	73	76738	URVB30/750	106
76246	HBRK-S/S -73	55	76463	MMPCP54	25	76636	SSTBK-W	73	76738	URVB30/750	109
76247	HDARK-S/S	42	76464	MMPCP60	25	76636	SSTBK-W	94	76739	URVB36/900	105
76248	HDMK-S/S	42	76465	MMPCP72	25	76636	SSTBK-W	96	76739	URVB36/900	105
76249	RSA	66	76466	MMPBPK	25	76637	SSTBK-B	73	76739	URVB36/900	106
76249	RSA	87	76467	HSHD-S/S	42	76637	SSTBK-B	73	76739	URVB36/900	106
76250	RC-S/S	66	76467	HSHD-S/S	47	76637	SSTBK-B	94	76739	URVB36/900	109
76250	RC-S/S	89	76467	HSHD-S/S	48	76637	SSTBK-B	96	76740	URVB42/1050	105
76318	CBD-XL-S/S	145	76467	HSHD-S/S	53	76638	MHCP-2BC24	32	76740	URVB42/1050	105
76319	URCB88/2200	109	76467	HSHD-S/S	54	76639	MHCP-2BC30	32	76740	URVB42/1050	106
76337	BP450-S/S	140	76472	FLEL-M	162	76640	MHCP-2BC36	32	76740	URVB42/1050	106
76338	BP600-S/S	140	76473	FLEL-L	162	76641	MHCP-2BC42	32	76740	URVB42/1050	109
76339	BP750-S/S	140	76474	FLELP	162	76642	MHCP-2BC48	32	76741	URVB48/1200	105
76340	BP800-S/S	140	76476	FLTW-M	162	76643	MHCP-2BC54	32	76741	URVB48/1200	105
76341	BP900-S/S	140	76477	FLTW-L	162	76644	MHCP-2BC60	32	76741	URVB48/1200	106
76342	BP1050-S/S	140	76478	FLRP	162	76645	MHCP-2BC72	32	76741	URVB48/1200	106
76343	BP1200-S/S	140	76479	FLCP	162	76658	HTF212	15	76741	URVB48/1200	109
76344	BP1400-S/S	140	76481	FLRLB-L	162	76659	HTF218	15	76742	URVB54/1350	105
76345	BP1500-S/S	140	76482	FLRLB-M	162	76660	HTF224	15	76742	URVB54/1350	105
76346	BP1600-S/S	140	76483	QMT-G	25	76661	HTF230	15	76742	URVB54/1350	106
76347	BP1800-S/S	140	76484	QMTS-G	25	76662	HTF236	15	76742	URVB54/1350	106
76375	AWT-1S	26	76484	QMT-G	107	76663	HTF242	15	76742	URVB54/1350	109
76375	AWT-1S	32	76485	TRB18	23	76664	HTF248	15	76743	URVB60/1500	105
76392	MHP-EP	25	76485	TRB18	25	76665	HTF254	15	76743	URVB60/1500	105
76392	MHP-EP	32	76485	TRB18	27	76666	HTF260	15	76743	URVB60/1500	106
76392	MHP-EP	48	76486	TRB24	23	76667	HTF272	15	76743	URVB60/1500	106
76392	MHP-EP	54	76486	TRB24	25	76668	CBC18	114	76743	URVB60/1500	109
76392	MHP-EP	79	76486	TRB24	27	76669	CBC24	114	76744	URVB72/1800	105
76392	MHP-EP	86	76487	TRB30	23	76670	CBC30	114	76744	URVB72/1800	105
76392	MHP-EP	93	76487	TRB30	25	76671	CBC36	114	76744	URVB72/1800	106
76392	MHP-EP	100	76487	TRB30	27	76672	CBC42	114	76744	URVB72/1800	106
76393	MHCP-CH	32	76488	TRB36	23	76673	CBC48	114	76744	URVB72/1800	109
76394	MHCP-BS	32	76488	TRB36	25	76674	CBC54	114	76745	URVB84/2100	105
76403	EST-P	17	76488	TRB36	27	76675	CBC60	114	76745	URVB84/2100	105
76404	EST-S	17	76489	TRB42	23	76676	CRD18	114	76745	URVB84/2100	106
76405	EST-B	17	76489	TRB42	25	76677	CRD24	114	76745	URVB84/2100	106
76406	ESTAK	17	76489	TRB42	27	76678	CRD30	114	76745	URVB84/2100	109
76406	ESTAK-EST	55	76490	TRB48	23	76679	CRD36	114	76748	URCB18/450	109
76406	ESTAK	107	76490	TRB48	25	76680	CRD42	114	76749	URCB24/600	109
76407	ESPSBK	17	76490	TRB48	27	76681	CRD48	114	76750	URCB30/750	109
76408	ESPBK	17	76491	TRB54	23	76682	CRD54	114	76751	URCB36/900	109
76409	ESPRK	17	76491	TRB54	25	76683	CRD60	114	76752	URCB42/1050	109
76410	ESBK-PS	17	76491	TRB54	27	76684	CDS18	114	76753	URCB48/1200	109
76411	ESBK-B	17	76492	TRB60	23	76685	CDS24	114	76754	URCB54/1350	109
76412	ESS-S	17	76492	TRB60	25	76686	CDS30	114	76755	URCB60/1500	109
76412	ESS-S	107	76492	TRB60	27	76687	CDS36	114	76756	URCB72/1800	109
76413	ESS-B	17	76493	TRB66	23	76688	CDS42	114	76757	URCB84/2100	109
76442	CBD-S	145	76493	TRB66	25	76689	CDS48	114	76786	USPB	107
76443	CBD-M	145	76493	TRB66	27	76690	CDS54	114	76786	USPB	108
76444	CBD-L	145	76494	TRB72	23	76691	CDS60	114	76787	UHPB	107
76445	CBD-XL	145	76494	TRB72	25	76692	CPB	114	76787	UHPB	108
76446	DBK-S	145	76494	TRB72	27	76697	TRB78	23	76788	ABU	107
76447	DBK-M	145	76537	MMPK	124	76697	TRB78	25	76788	ABU	107
76448	DBK-L	145	76540	QMTBK-G	25	76697	TRB78	27	76788	ABU	108
76449	DBK-XL	145	76540	QMTBK-G	27	76736	URVB18/450	105	76788	ABU	108
76450	MMP-624	23	76558	RMC-FS	161	76736	URVB18/450	105	76790	USPK	107
76451	MMP-630	23	76593	CRB-HT10	19	76736	URVB18/450	106	76798	MMP-684	23
76452	MMP-636	23	76594	CRB-HT16	19	76736	URVB18/450	106	76800	MHCP-84S	30
76453	MMP-642	23	76595	CRB-HT22	19	76736	URVB18/450	109	76801	MHCP-84A	30
76454	MMP-648	23	76596	CRB-HT28	19	76737	URVB24/600	105	76808	MMPCP84	25
76455	MMP-654	23	76597	CRB-HT34	19	76737	URVB24/600	105	76811	MHP-CP2100	32

INDEX By Item Code

Item Code	Ordering Number	Page #	Item Code	Ordering Number	Page #	Item Code	Ordering Number	Page #	Item Code	Ordering Number	Page #
76812	MHCP-2BC84	32	76882	DRXH-36-420	137	76934	IBS-DH5	138	77117	LS-SW	12
76816	DRXL-24-420	135	76883	DRXH-42-420	137	76935	ISABK	138	77118	LS-SS	12
76817	DRXL-30-420	135	76884	DRXH-48-420	137	76936	IMK	135	77118	LS-SS	13
76818	DRXL-36-420	135	76885	DRXH-54-420	137	76936	IMK	136	77120	LST-TAK	12
76819	DRXL-42-420	135	76886	DRXH-60-420	137	76936	IMK	137	77120	LST-TAK	13
76820	DRXL-48-420	135	76887	DRXH-72-420	137	76937	IEA42-60D	138	77121	LST-P	12
76821	DRXL-54-420	135	76888	DRXH-24-520	137	76938	IEA72-96D	138	77122	LST-W	12
76822	DRXL-60-420	135	76889	DRXH-30-520	137	76939	HW-IMPB	139	77123	LST-S	12
76823	DRXL-72-420	135	76890	DRXH-36-520	137	76950	OIBBK	139	77124	LST-B-S/S	13
76824	DRXL-24-520	135	76891	DRXH-42-520	137	76965	IB4-1U	139	77125	LST-W-S/S	13
76825	DRXL-30-520	135	76892	DRXH-48-520	137	76966	IB5-1U	139	77126	LST-W-S/S-2	13
76826	DRXL-36-520	135	76893	DRXH-54-520	137	76979	FL-M	162	77127	EZP-LS212	10
76827	DRXL-42-520	135	76894	DRXH-60-520	137	76980	FL-L	162	77128	EZP-LS218	10
76828	DRXL-48-520	135	76895	DRXH-72-520	137	76983	FL-XL	162	77129	EZP-LS224	10
76829	DRXL-54-520	135	76896	DRXH-24-435	137	76984	FLVRL-XL	162	77130	EZP-LS230	10
76830	DRXL-60-520	135	76897	DRXH-30-435	137	76985	FLTW-XL	162	77131	EZP-LS236	10
76831	DRXL-72-520	135	76898	DRXH-36-435	137	76986	FLELK-XL	162	77132	EZP-LS242	10
76832	DRXL-24-435	135	76899	DRXH-42-435	137	77031	CSTAK	94	77133	EZP-LS248	10
76833	DRXL-30-435	135	76900	DRXH-48-435	137	77031	CSTAK	96	77134	EZP-LS254	10
76834	DRXL-36-435	135	76901	DRXH-54-435	137	77037	CSTBK	94	77135	EZP-LS260	10
76835	DRXL-42-435	135	76902	DRXH-60-435	137	77037	CSTBK	96	77144	EZP-LS212	10
76836	DRXL-48-435	135	76903	DRXH-72-435	137	77047	TRB84	25	77145	CLSFG-218	10
76837	DRXL-54-435	135	76904	DRXH-24-535	137	77047	TRB84	27	77146	CLSFG-224	10
76838	DRXL-60-435	135	76905	DRXH-30-535	137	77048	TRB90	25	77147	CLSFG-230	10
76839	DRXL-72-435	135	76906	DRXH-36-535	137	77048	TRB90	27	77148	CLSFG-236	10
76840	DRXL-24-535	135	76907	DRXH-42-535	137	77052	SACSK	94	77149	CLSFG-242	10
76841	DRXL-30-535	135	76908	DRXH-48-535	137	77052	SACSK	96	77150	CLSFG-248	10
76842	DRXL-36-535	135	76909	DRXH-54-535	137	77065	SACSRC	94	77151	CLSFG-254	10
76843	DRXL-42-535	135	76910	DRXH-60-535	137	77065	SACSRC	96	77152	CLSFG-260	10
76844	DRXL-48-535	135	76911	DRXH-72-535	137	77070	LSP12	12	77259	UTV450J-S/S	106
76845	DRXL-54-535	135	76912	DRXD-42-520	138	77071	LSP18	12	77260	UTV600J-S/S	106
76846	DRXL-60-535	135	76913	DRXD-48-520	138	77072	LSP24	12	77261	UTV750J-S/S	106
76847	DRXL-72-535	135	76914	DRXD-54-520	138	77073	LSP30	12	77262	UTV900J-S/S	106
76848	DRXM-24-420	136	76915	DRXD-60-520	138	77074	LSP36	12	77263	UTV1050J-S/S	106
76849	DRXM-30-420	136	76916	DRXD-72-520	138	77075	LSP42	12	77264	UTV1200J-S/S	106
76850	DRXM-36-420	136	76917	DRXD-84-520	138	77076	LSP48	12	77265	UTV1350J-S/S	106
76851	DRXM-42-420	136	76918	DRXD-96-520	138	77077	LSP54	12	77266	UTV1400J-S/S	106
76852	DRXM-48-420	136	76919	DRXD-42-535	138	77078	LSP60	12	77267	UTV1500J-S/S	106
76853	DRXM-54-420	136	76920	DRXD-48-535	138	77079	LSP12-S/S	13	77268	UTV1600J-S/S	106
76854	DRXM-60-420	136	76921	DRXD-54-535	138	77080	LSP18-S/S	13	77269	UTV1800J-S/S	106
76855	DRXM-72-420	136	76922	DRXD-60-535	138	77081	LSP24-S/S	13	77270	UTV2000J-S/S	106
76856	DRXM-24-520	136	76923	DRXD-72-535	138	77082	LSP30-S/S	13	77271	UTV2100J-S/S	106
76857	DRXM-30-520	136	76924	DRXD-84-535	138	77083	LSP36-S/S	13	77272	UTV2200J-S/S	106
76858	DRXM-36-520	136	76925	DRXD-96-535	138	77084	LSP42-S/S	13	77283	UTV450-J	106
76859	DRXM-42-520	136	76926	IB4	129	77085	LSP48-S/S	13	77284	UTV600-J	106
76860	DRXM-48-520	136	76926	IB4	131	77086	LSP54-S/S	13	77285	UTV750-J	106
76861	DRXM-54-520	136	76926	IB4	133	77087	LSP60-S/S	13	77286	UTV900-J	106
76862	DRXM-60-520	136	76926	IB4	135	77088	CRB-LS10	14	77287	UTV1050-J	106
76863	DRXM-72-520	136	76926	IB4	136	77089	CRB-LS16	14	77288	UTV1200-J	106
76864	DRXM-24-435	136	76926	IB4	137	77090	CRB-LS22	14	77289	UTV1350-J	106
76865	DRXM-30-435	136	76927	IB5	129	77091	CRB-LS28	14	77290	UTV1400-J	106
76866	DRXM-36-435	136	76927	IB5	131	77092	CRB-LS34	14	77291	UTV1500-J	106
76867	DRXM-42-435	136	76927	IB5	133	77093	CRB-LS40	14	77292	UTV1600-J	106
76868	DRXM-48-435	136	76927	IB5	135	77094	CRB-LS46	14	77293	UTV1800-J	106
76869	DRXM-54-435	136	76927	IB5	136	77095	CRB-LS52	14	77294	UTV2000-J	106
76870	DRXM-60-435	136	76927	IB5	137	77096	CRB-LS58	14	77295	UTV2100-J	106
76871	DRXM-72-435	136	76927	IB5	138	77097	CRB-LS10W	14	77296	UTV2200-J	106
76872	DRXM-24-535	136	76928	IBBK	135	77098	CRB-LS16W	14	77297	UTV450	105
76873	DRXM-30-535	136	76928	IBBK	136	77099	CRB-LS22W	14	77298	UTV600	105
76874	DRXM-36-535	136	76928	IBBK	137	77100	CRB-LS28W	14	77299	UTV750	105
76875	DRXM-42-535	136	76928	IBBK	138	77101	CRB-LS34W	14	77300	UTV900	105
76876	DRXM-48-535	136	76929	IBS-L4	135	77102	CRB-LS40W	14	77301	UTV1050	105
76877	DRXM-54-535	136	76930	IBS-L5	135	77103	CRB-LS46W	14	77302	UTV1200	105
76878	DRXM-60-535	136	76931	IBS-M4	136	77104	CRB-LS52W	14	77303	UTV1350	105
76879	DRXM-72-535	136	76932	IBS-M5	136	77105	CRB-LS58W	14	77304	UTV1400	105
76880	DRXH-24-420	137	76933	IBS-H4	137	77114	LS-BP	12	77305	UTV1500	105
76881	DRXH-30-420	137	76934	IBS-DH5	137	77115	LS-BP-S/S	13	77306	UTV1600	105

INDEX By Item Code

Item Code	Ordering Number	Page #	Item Code	Ordering Number	Page #	Item Code	Ordering Number	Page #	Item Code	Ordering Number	Page #
77307	UTV1800	105	77391	SPG-CVR-E	22	77497	MHS-2100BTV-S/S	70	77527	MHS-P1200*	71
77308	UTV2000	105	77391	SPG-CVR-E	76	77498	MHS-2400BTV-S/S	70	77527	MHS-P1200*	73
77309	UTV2100	105	77391	SPG-CVR-E	104	77499	MHS-P600	68	77528	MHS-P1200S/S	68
77310	UTV2200	105	77392	SPG-CVR-F	22	77499	MHS-P600*	71	77528	MHS-P1200S/S*	71
77314	URVB56/1400	105	77392	SPG-CVR-F	76	77499	MHS-P600*	73	77528	MHS-P1200S/S*	73
77314	URVB56/1400	105	77392	SPG-CVR-F	104	77500	MHS-P750	68	77529	ISABK-LMH	135
77314	URVB56/1400	106	77393	SPG-CVR-G	22	77500	MHS-P750*	71	77529	ISABK-LMH	136
77314	URVB56/1400	106	77393	SPG-CVR-G	76	77500	MHS-P750*	73	77529	ISABK-LMH	137
77314	URVB56/1400	109	77393	SPG-CVR-G	104	77501	MHS-P900	68	77548	SHIM-KITL	135
77315	URVB64/1600	105	77411	UTV2400	105	77501	MHS-P900*	71	77549	SHIM-KITM	136
77315	URVB64/1600	105	77412	UTV2500	105	77501	MHS-P900*	73	77550	SHIM-KITH	137
77315	URVB64/1600	106	77413	UTV2400-J	106	77502	MHS-P1050	68	77552	CRB-LS16HT	14
77315	URVB64/1600	106	77414	UTV2500-J	106	77502	MHS-P1050*	71	77553	CRB-LS22HT	14
77315	URVB64/1600	109	77417	UTV2400J-S/S	106	77502	MHS-P1050*	73	77554	CRB-LS28HT	14
77316	URVB88/2200	105	77418	UTV2500J-S/S	106	77503	MHS-P1350	68	77555	CRB-LS34HT	14
77316	URVB88/2200	105	77418	USP98/2500-S/S	108	77503	MHS-P1350*	71	77556	CRB-LS40HT	14
77316	URVB88/2200	106	77419	USP94/2400-S/S	108	77503	MHS-P1350*	73	77557	CRB-LS46HT	14
77316	URVB88/2200	106	77421	URVB94/2400	105	77504	MHS-P1500	68	77558	CRB-LS52HT	14
77316	URVB88/2200	109	77421	URVB94/2400	105	77504	MHS-P1500*	71	77559	CRB-LS58HT	14
77317	URCB56/1400	109	77421	URVB94/2400	106	77504	MHS-P1500*	73	77582	MSPMPK-S/S	27
77318	URCB64/1600	109	77421	URVB94/2400	106	77505	MHS-P1800	68	77583	MSPBPK-S/S	18
77320	URVB80/2000	105	77421	URVB94/2400	109	77505	MHS-P1800*	71	77584	QMT-P-S/S	27
77320	URVB80/2000	105	77422	URVB98/2500	105	77505	MHS-P1800*	73	77585	QMT-W-S/S	27
77320	URVB80/2000	106	77422	URVB98/2500	105	77506	MHS-P2100	68	77586	QMT-G-S/S	27
77320	URVB80/2000	106	77422	URVB98/2500	106	77506	MHS-P2100*	71	77587	QMTPAK-S/S	27
77320	URVB80/2000	109	77422	URVB98/2500	106	77506	MHS-P2100*	73	77588	QMTPSBK-S/S	27
77321	URCB80/2000	109	77422	URVB98/2500	109	77507	MHS-P2400	68	77590	MMPCP24-S/S	27
77324	MMKU	107	77424	MMP-624-S/S	24	77507	MHS-P2400*	71	77591	MMPCP30-S/S	27
77327	MMKUHD	107	77425	MMP-630-S/S	24	77507	MHS-P2400*	73	77592	MMPCP36-S/S	27
77329	HDARK	107	77426	MMP-636-S/S	24	77508	MHS-P600S/S	68	77593	MMPCP42-S/S	27
77331	HDARK-S/S	108	77427	MMP-642-S/S	24	77508	MHS-P600S/S*	71	77594	MMPCP48-S/S	27
77332	STJM-S/S	108	77428	MMP-648-S/S	24	77508	MHS-P600S/S*	73	77595	MMPCP54-S/S	27
77339	USP18/450-S/S	108	77429	MMP-654-S/S	24	77509	MHS-P750S/S	68	77596	MMPCP60-S/S	27
77340	USP24/600-S/S	108	77430	MMP-660-S/S	24	77509	MHS-P750S/S*	71	77597	MMPCP72-S/S	27
77341	USP30/750-S/S	108	77431	MMP-672-S/S	24	77509	MHS-P750S/S*	73	77598	MMPCP84-S/S	27
77342	USP36/900-S/S	108	77432	MMP-684-S/S	24	77510	MHS-P900S/S	68	77599	MHP-EP-S/S	27
77343	USP42/1050-S/S	108	77442	PSTA-S/S	27	77510	MHS-P900S/S*	71	77599	MHP-EP-S/S	48
77344	USP48/1200-S/S	108	77443	TEN-LOCK-KIT	22	77510	MHS-P900S/S*	73	77599	MHP-EP-S/S	54
77345	USP54/1350-S/S	108	77443	TEN-LOCK-KIT	76	77511	MHS-P1050S/S	68	77599	MHP-EP-S/S	81
77346	USP56/1400-S/S	108	77443	TEN-LOCK-KIT	104	77511	MHS-P1050S/S*	71	77599	MHP-EP-S/S	88
77347	USP60/1500-S/S	108	77448	URCB94/2400	109	77511	MHS-P1050S/S*	73	77599	MHP-EP-S/S	95
77348	USP64/1600-S/S	108	77449	URCB98/2500	109	77512	MHS-P1350S/S	68	77599	MHP-EP-S/S	101
77349	USP72/1800-S/S	108	77450	QMTS-P-S/S	18	77512	MHS-P1350S/S*	71	77600	MMBPBK-S/S	27
77350	USP80/2000-S/S	108	77450	QMTS-P-S/S	27	77512	MHS-P1350S/S*	73	77630	STS-W-S/S	68
77351	USP84/2100-S/S	108	77450	QMTS-P-SS	108	77513	MHS-P1500S/S	68	77630	STS-W-S/S	73
77352	USP88/2200-S/S	108	77451	QMTS-W-S/S	18	77513	MHS-P1500S/S*	71	77630	STS-W-S/S	96
77357	MMKU-SS	108	77451	QSTS-W-S/S	27	77513	MHS-P1500S/S*	73	77631	STS-S-S/S	68
77358	MMKUHD-SS	108	77451	QMTS-W-SS	108	77514	MHS-P1800S/S	68	77631	STS-S-S/S	73
77364	HARK-S/S	108	77452	QMTS-G-S/S	18	77514	MHS-P1800S/S*	71	77631	STS-S-S/S	96
77365	LS-SP	12	77452	QMTS-G-S/S	27	77514	MHS-P1800S/S*	73	77632	STS-B-S/S	55
77366	LSTMPK	12	77452	QMTS-G-SS	108	77515	MHS-P2100S/S	68	77632	STS-B-S/S	55
77367	LSTPB-RK	12	77481	MHS-600BTV	70	77515	MHS-P2100S/S*	71	77632	STS-B-S/S	68
77367	LSTPB-RK	13	77482	MHS-750BTV	70	77515	MHS-P2100S/S*	73	77632	STS-B-S/S	73
77384	EZPTBT	21	77483	MHS-900BTV	70	77516	MHS-P2400S/S	68	77632	STS-B-S/S	96
77385	EZPTBTHD	21	77484	MHS-1050BTV	70	77516	MHS-P2400S/S*	71	77633	STHDPM2-S/S	73
77387	SPG-CVR-A	22	77485	MHS-1350BTV	70	77516	MHS-P2400S/S*	73	77633	STHDPM2-S/S	96
77387	SPG-CVR-A	76	77486	MHS-1500BTV	70	77518	HXF8SS-Blue	36	77634	STHDMK2-S/S	73
77387	SPG-CVR-A	104	77487	MHS-1800BTV	70	77518	HXF8SS-Blue	37	77634	STHDMK2-S/S	96
77388	SPG-CVR-B	22	77488	MHS-2100BTV	70	77519	HXF8S-Blue	36	77635	STGK2	73
77388	SPG-CVR-B	76	77489	MHS-2400BTV	70	77519	HXF8S-Blue	37	77635	STGK2	73
77388	SPG-CVR-B	104	77490	MHS-600BTV-S/S	70	77520	HXF8M-Blue	36	77635	STGK2	94
77389	SPG-CVR-C	22	77491	MHS-750BTV-S/S	70	77520	HXF8M-Blue	37	77635	STGK2	96
77389	SPG-CVR-C	76	77492	MHS-900BTV-S/S	70	77521	HXF8L-Blue	36	77664	PTS-18R	151
77389	SPG-CVR-C	104	77493	MHS-1050BTV-S/S	70	77521	HXF8L-Blue	37	77665	PTS-24R	151
77390	SPG-CVR-D	22	77494	MHS-1350BTV-S/S	70	77525	MHS-1200BTV	70	77666	PTS-30R	151
77390	SPG-CVR-D	76	77495	MHS-1500BTV-S/S	70	77526	MHS-1200BTV-S/S	70	77667	PTS-36R	151
77390	SPG-CVR-D	104	77496	MHS-1800BTV-S/S	70	77527	MHS-P1200	68	77668	PTS-42R	151

INDEX By Item Code

Item Code	Ordering Number	Page #	Item Code	Ordering Number	Page #	Item Code	Ordering Number	Page #	Item Code	Ordering Number	Page #
77669	PTS-48R	151	77866	SAC2-TIP-TL	89	77894	SACPL-72/1800	79	78008	MHS-750BTV-SAC	98
77670	PTS-54R	151	77866	SAC2-TIP-TL	94	77894	SACPL-72/1800	86	78009	MHS-900BTV-SAC	98
77671	PTS-60R	151	77866	SAC2-TIP-TL	96	77894	SACPL-72/1800	93	78010	MHS-1050BTV-SAC	98
77672	PTS-72R	151	77866	SAC2-TIP-TL	100	77894	SACPL-72/1800	100	78011	MHS-1200BTV-SAC	98
77680	PTS-RR21	151	77866	SAC2-TIP-TL	102	77895	SACPL2-60/1500	79	78012	MHS-1350BTV-SAC	98
77681	PTS-RR27	151	77868	SSTHDPM	73	77895	SACPL2-60/1500	86	78013	MHS-1500BTV-SAC	98
77682	PTS-RR33	151	77868	SSTHDPM	94	77895	SACPL2-60/1500	93	78014	MHS-1800BTV-SAC	98
77683	PTS-RR39	151	77869	CSTHDPM	94	77895	SACPL2-60/1500	100	78015	MHS-1500BTV-2SAC	98
77684	PTS-RR45	151	77870	SSTHDMK	73	77896	SACPL2-72/1800	79	78016	MHS-1800BTV-2SAC	98
77685	PTS-RR51	151	77870	SSTHDMK	93	77896	SACPL2-72/1800	86	78017	MHS-2100BTV-2SAC	98
77686	PTS-RR57	151	77871	CSTHDMK	94	77896	SACPL2-72/1800	93	78018	MHS-2400BTV-2SAC	98
77687	PTS-RR63	151	77882	SACRKN	47	77896	SACPL2-72/1800	100	78019	MHS-3000BTV-2SAC	98
77689	PTS-RR75	151	77882	SACRKN	80	77897	SACPL2-84/2100	79	78020	PV600-SAC	77
77691	PTS-SR	152	77882	SACRKN	82	77897	SACPL2-84/2100	86	78021	PV750-SAC	77
77692	PTS-HDSR	152	77882	SACRKN	87	77897	SACPL2-84/2100	93	78022	PV900-SAC	77
77693	PTS-ABK	152	77882	SACRKN	89	77897	SACPL2-84/2100	100	78023	PV1050-SAC	77
77694	PTS-SAK	152	77882	SACRKN	94	77898	SACPL2-96/2400	79	78024	PV1200-SAC	77
77696	PTS-IBK	152	77882	SACRKN	96	77898	SACPL2-96/2400	86	78025	PV1350-SAC	77
77697	PTS-HIBK	152	77882	SACRKN	100	77898	SACPL2-96/2400	93	78026	PV1500-SAC	77
77698	PTS-PS	152	77882	SACRKN	102	77898	SACPL2-96/2400	100	78027	PV1800-SAC	77
77699	PTS-PA	152	77883	SACRH	47	77899	SACPL2-120/3000	79	78028	PV1500-2SAC	77
77700	PTS-MBK	152	77883	SACRH	80	77899	SACPL2-120/3000	86	78029	PV1800-2SAC	77
77701	PTS-MBKUG	152	77883	SACRH	87	77899	SACPL2-120/3000	93	78030	PV2100-2SAC	77
77702	PTS-EBK	152	77883	SACRH	94	77899	SACPL2-120/3000	100	78031	PV2400-2SAC	77
77729		162	77883	SACRH	100	77913	PCAP-24/600	80	78032	PV3000-2SAC	77
77741	SPG-CVR-H	22	77884	SACRHL	47	77914	PCAP-30/750	80	78033	RV600-SAC	84
77741	SPG-CVR-H	76	77884	SACRHL	80	77915	PCAP-36/900	80	78034	RV750-SAC	84
77741	SPG-CVR-H	104	77884	SACRHL	87	77916	PCAP-42/1050	80	78035	RV900-SAC	84
77742	CTS-W	94	77884	SACRHL	94	77917	PCAP-48/1200	80	78036	RV1050-SAC	84
77743	CTS-S	61	77884	SACRHL	100	77918	PCAP-54/1350	80	78037	RV1200-SAC	84
77743	CTS-S	94	77885	SACKRP	47	77919	PCAP-60/1500	80	78038	RV1350-SAC	84
77744	CTS-B	94	77885	SACKRP	80	77920	PCAP-72/1800	80	78039	RV1500-SAC	84
77745	CTS-G	94	77885	SACKRP	87	77921	RCAP-24/600	87	78040	RV1800-SAC	84
77746	EZP-LS212HT	10	77885	SACKRP	94	77922	RCAP-30/750	87	78041	RV1500-2SAC	84
77747	EZP-LS218HT	10	77885	SACKRP	100	77923	RCAP-36/900	87	78042	RV1800-2SAC	84
77748	EZP-LS224HT	10	77886	SACRKT	80	77924	RCAP-42/1050	87	78043	RV2100-2SAC	84
77749	EZP-LS230HT	10	77886	SACRKT	87	77925	RCAP-48/1200	87	78044	RV2400-2SAC	84
77750	EZP-LS236HT	10	77886	SACRKT	94	77926	RCAP-54/1350	87	78045	RV3000-2SAC	84
77751	EZP-LS242HT	10	77886	SACRKT	100	77927	RCAP-60/1500	87	78080	P-CARK-V24/600	78
77752	EZP-LS248HT	10	77887	SACPL-24/600	79	77928	RCAP-72/1800	87	78081	P-CARK-V30/750	78
77753	EZP-LS254HT	10	77887	SACPL-24/600	86	77937	MHS-CARK-V24/600	92	78082	P-CARK-V36/900	78
77754	EZP-LS260HT	10	77887	SACPL-24/600	93	77937	MHS-CARK-V24/600	99	78083	P-CARK-V42/1050	78
77755	PTS-RHSAA	152	77887	SACPL-24/600	100	77938	MHS-CARK-V30/750	92	78084	P-CARK-V48/1200	78
77756	PTS-LHSAA	152	77888	SACPL-30/750	79	77938	MHS-CARK-V30/750	99	78085	P-CARK-V54/1350	78
77789	MHS-600FPV	72	77888	SACPL-30/750	86	77939	MHS-CARK-V36/900	92	78086	P-CARK-V60/1500	78
77790	MHS-750FPV	72	77888	SACPL-30/750	93	77939	MHS-CARK-V36/900	99	78087	P-CARK-V72/1800	78
77791	MHS-900FPV	72	77888	SACPL-30/750	100	77940	MHS-CARK-V42/1050	92	78093	P-CARK2-V60/1500	78
77792	MHS-1050FPV	72	77889	SACPL-36/900	79	77940	MHS-CARK-V42/1050	99	78094	P-CARK2-V72/1800	78
77793	MHS-1200FPV	72	77889	SACPL-36/900	86	77941	MHS-CARK-V48/1200	92	78095	P-CARK2-V84/2100	78
77794	MHS-1350FPV	72	77889	SACPL-36/900	93	77941	MHS-CARK-V48/1200	99	78096	P-CARK2-V96/2400	78
77795	MHS-1500FPV	72	77889	SACPL-36/900	100	77942	MHS-CARK-V54/1350	92	78097	P-CARK2-V120/3000	78
77796	MHS-1800FPV	72	77890	SACPL-42/1050	79	77942	MHS-CARK-V54/1350	99	78106	R-CARK-V24/600	85
77797	MHS-2100FPV	72	77890	SACPL-42/1050	86	77943	MHS-CARK-V60/1500	92	78107	R-CARK-V30/750	85
77798	MHS-2400FPV	72	77890	SACPL-42/1050	93	77943	MHS-CARK-V60/1500	99	78108	R-CARK-V36/900	85
77799	MHS-600FPV-S/S	72	77890	SACPL-42/1050	100	77944	MHS-CARK-V72/1800	92	78109	R-CARK-V42/1050	85
77800	MHS-750FPV-S/S	72	77891	SACPL-48/1200	79	77944	MHS-CARK-V72/1800	99	78110	R-CARK-V48/1200	85
77801	MHS-900FPV-S/S	72	77891	SACPL-48/1200	86	77950	MHS-CARK2-V60/1500	92	78111	R-CARK-V54/1350	85
77802	MHS-1050FPV-S/S	72	77891	SACPL-48/1200	93	77950	MHS-CARK2-V60/1500	99	78112	R-CARK-V60/1500	85
77803	MHS-1200FPV-S/S	72	77891	SACPL-48/1200	100	77951	MHS-CARK2-V72/1800	92	78113	R-CARK-V72/1800	85
77804	MHS-1350FPV-S/S	72	77892	SACPL-54/1350	79	77951	MHS-CARK2-V72/1800	99	78119	R-CARK2-V60/1500	85
77805	MHS-1500FPV-S/S	72	77892	SACPL-54/1350	86	77952	MHS-CARK2-V84/2100	92	78120	R-CARK2-V72/1800	85
77806	MHS-1800FPV-S/S	72	77892	SACPL-54/1350	93	77952	MHS-CARK2-V84/2100	99	78121	R-CARK2-V84/2100	85
77807	MHS-2100FPV-S/S	72	77892	SACPL-54/1350	100	77953	MHS-CARK2-V96/2400	92	78122	R-CARK2-V96/2400	85
77808	MHS-2400FPV-S/S	72	77893	SACPL-60/1500	79	77953	MHS-CARK2-V96/2400	99	78123	R-CARK2-V120/3000	85
77866	SAC2-TIP-TL	80	77893	SACPL-60/1500	86	77954	MHS-CARK2-V120/3000	92	78142	STS-G	55
77866	SAC2-TIP-TL	82	77893	SACPL-60/1500	93	77954	MHS-CARK2-V120/3000	99	78142	STS-G	55
77866	SAC2-TIP-TL	87	77893	SACPL-60/1500	100	78007	MHS-600BTV-SAC	98	78142	STS-G	68

INDEX By Item Code

Item Code	Ordering Number	Page #	Item Code	Ordering Number	Page #	Item Code	Ordering Number	Page #	Item Code	Ordering Number	Page #
78142	STS-G	73	78368	RCAP-54/1350-S/S	89	78394	SST1HDM-W-S/S	96	78544	MHS-1800V-SAC-S/S	91
78142	STS-G	94	78369	RCAP-60/1500-S/S	89	78395	SST1HDM-S-S/S	73	78545	MHS-1500V-2SAC-S/S	91
78162	MHS-600V-SAC	91	78370	RCAP-72/1800-S/S	89	78395	SST1HDM-S-S/S	96	78546	MHS-1800V-2SAC-S/S	91
78163	MHS-750V-SAC	91	78371	SACPL-24/600-S/S	81	78396	SST1HDM-B-S/S	73	78547	MHS-2100V-2SAC-S/S	91
78164	MHS-900V-SAC	91	78371	SACPL-24/600-S/S	88	78396	SST1HDM-B-S/S	96	78548	MHS-2400V-2SAC-S/S	91
78165	MHS-1050V-SAC	91	78371	SACPL-24/600-S/S	95	78397	SACRH-S/S	82	78549	MHS-3000V-2SAC-S/S	91
78166	MHS-1200V-SAC	91	78371	SACPL-24/600-S/S	101	78397	SACRH-S/S	89	78576	CART-24/600-S/S	47
78167	MHS-1350V-SAC	91	78372	SACPL-30/750-S/S	81	78397	SACRH-S/S	96	78576	CART-24/600-S/S	53
78168	MHS-1500V-SAC	91	78372	SACPL-30/750-S/S	88	78397	SACRH-S/S	102	78576	CART-24/600-S/S	79
78169	MHS-1800V-SAC	91	78372	SACPL-30/750-S/S	95	78398	SACRHL-S/S	82	78576	CART-24/600-S/S	81
78170	MHS-1500V-2SAC	91	78372	SACPL-30/750-S/S	101	78398	SACRHL-S/S	89	78576	CART-24/600-S/S	86
78171	MHS-1800V-2SAC	91	78373	SACPL-36/900-S/S	81	78398	SACRHL-S/S	96	78576	CART-24/600-S/S	88
78172	MHS-2100V-2SAC	91	78373	SACPL-36/900-S/S	88	78398	SACRHL-S/S	102	78576	CART-24/600-S/S	93
78173	MHS-2400V-2SAC	91	78373	SACPL-36/900-S/S	95	78399	SACKRP-S/S	82	78576	CART-24/600-S/S	95
78174	MHS-3000V-2SAC	91	78373	SACPL-36/900-S/S	101	78399	SACKRP-S/S	89	78576	CART-24/600-S/S	100
78316	MHS-600BTB-SAC-S/S	98	78374	SACPL-42/1050-S/S	81	78399	SACKRP-S/S	96	78576	CART-24/600-S/S	101
78317	MHS-750BTB-SAC-S/S	98	78374	SACPL-42/1050-S/S	88	78399	SACKRP-S/S	102	78577	CART-30/750-S/S	79
78318	MHS-900BTB-SAC-S/S	98	78374	SACPL-42/1050-S/S	95	78401	SACRKT-S/S	82	78577	CART-30/750-S/S	81
78319	MHS-1050BTB-SAC-S/S	98	78374	SACPL-42/1050-S/S	101	78401	SACRKT-S/S	89	78577	CART-30/750-S/S	86
78320	MHS-1200BTB-SAC-S/S	98	78375	SACPL-48/1200-S/S	81	78401	SACRKT-S/S	96	78577	CART-30/750-S/S	88
78321	MHS-1350BTB-SAC-S/S	98	78375	SACPL-48/1200-S/S	88	78401	SACRKT-S/S	102	78577	CART-30/750-S/S	93
78322	MHS-1500BTB-SAC-S/S	98	78375	SACPL-48/1200-S/S	95	78456	SSFRB	32	78577	CART-30/750-S/S	95
78323	MHS-1800BTB-SAC-S/S	98	78375	SACPL-48/1200-S/S	101	78456	SSFRB	35	78577	CART-30/750-S/S	100
78324	MHS-1500BTB-2SAC-S/S	98	78376	SACPL-54/1350-S/S	81	78462	LSTMPK2-S/S	13	78577	CART-30/750-S/S	101
78325	MHS-1800BTB-2SAC-S/S	98	78376	SACPL-54/1350-S/S	88	78472	CRB-W16	19	78578	CART-36/900-S/S	47
78326	MHS-2100BTB-2SAC-S/S	98	78376	SACPL-54/1350-S/S	95	78473	CRB-W22	19	78578	CART-36/900-S/S	53
78327	MHS-2400BTB-2SAC-S/S	98	78376	SACPL-54/1350-S/S	101	78474	CRB-W28	19	78578	CART-36/900-S/S	79
78328	MHS-3000BTB-2SAC-S/S	98	78377	SACPL-60/1500-S/S	81	78475	CRB-W34	19	78578	CART-36/900-S/S	81
78329	PV600-SAC-S/S	77	78377	SACPL-60/1500-S/S	88	78476	CRB-W40	19	78578	CART-36/900-S/S	86
78330	PV750-SAC-S/S	77	78377	SACPL-60/1500-S/S	95	78477	CRB-W46	19	78578	CART-36/900-S/S	88
78331	PV900-SAC-S/S	77	78377	SACPL-60/1500-S/S	101	78478	CRB-W52	19	78578	CART-36/900-S/S	93
78332	PV1050-SAC-S/S	77	78378	SACPL-72/1800-S/S	81	78479	CRB-W58	19	78578	CART-36/900-S/S	95
78333	PV1200-SAC-S/S	77	78378	SACPL-72/1800-S/S	88	78480	CRB-W64	19	78578	CART-36/900-S/S	100
78334	PV1350-SAC-S/S	77	78378	SACPL-72/1800-S/S	95	78481	CRB-W70	19	78578	CART-36/900-S/S	101
78335	PV1500-SAC-S/S	77	78378	SACPL-72/1800-S/S	101	78488	EZP1T-212	20	78579	CART-42/1050-S/S	47
78336	PV1800-SAC-S/S	77	78379	SACPL2-60/1500-S/S	81	78489	EZP1T-218	20	78579	CART-42/1050-S/S	53
78337	PV1500-2SAC-S/S	77	78379	SACPL2-60/1500-S/S	88	78490	EZP1T-224	20	78579	CART-42/1050-S/S	79
78338	PV1800-2SAC-S/S	77	78379	SACPL2-60/1500-S/S	95	78491	EZP1T-230	20	78579	CART-42/1050-S/S	81
78339	PV2100-2SAC-S/S	77	78379	SACPL2-60/1500-S/S	101	78492	EZP1T-236	20	78579	CART-42/1050-S/S	86
78340	PV2400-2SAC-S/S	77	78380	SACPL2-72/1800-S/S	81	78493	EZP1T-242	20	78579	CART-42/1050-S/S	88
78341	PV3000-2SAC-S/S	77	78380	SACPL2-72/1800-S/S	88	78494	EZP1T-248	20	78579	CART-42/1050-S/S	93
78342	RV600-SAC-S/S	84	78380	SACPL2-72/1800-S/S	95	78495	EZP1T-254	20	78579	CART-42/1050-S/S	95
78343	RV750-SAC-S/S	84	78380	SACPL2-72/1800-S/S	101	78496	EZP1T-260	20	78579	CART-42/1050-S/S	100
78344	RV900-SAC-S/S	84	78381	SACPL2-84/2100-S/S	81	78497	EZP1T-272	20	78579	CART-42/1050-S/S	101
78345	RV1050-SAC-S/S	84	78381	SACPL2-84/2100-S/S	88	78507	EZPTMPK	21	78580	CART2-48/1200-S/S	47
78346	RV1200-SAC-S/S	84	78381	SACPL2-84/2100-S/S	95	78508	EZPTCK	21	78580	CART2-48/1200-S/S	53
78347	RV1350-SAC-S/S	84	78381	SACPL2-84/2100-S/S	101	78509	EZPTCKHD	21	78580	CART-48/1200-S/S	79
78348	RV1500-SAC-S/S	84	78382	SACPL2-96/2400-S/S	81	78510	EZPTSR	21	78580	CART-48/1200-S/S	81
78349	RV1800-SAC-S/S	84	78382	SACPL2-96/2400-S/S	88	78511	EZPTSK	21	78580	CART-48/1200-S/S	86
78350	RV1500-2SAC-S/S	84	78382	SACPL2-96/2400-S/S	95	78512	EZPTSKHD	21	78580	CART-48/1200-S/S	88
78351	RV1800-2SAC-S/S	84	78382	SACPL2-96/2400-S/S	101	78513	CST1HDM-W	94	78580	CART-48/1200-S/S	93
78352	RV2100-2SAC-S/S	84	78383	SACPL2-120/3000-S/S	81	78514	CST1HDM-S	94	78580	CART-48/1200-S/S	95
78353	RV2400-2SAC-S/S	84	78383	SACPL2-120/3000-S/S	88	78515	CST1HDM-B	94	78580	CART-48/1200-S/S	100
78354	RV3000-2SAC-S/S	84	78383	SACPL2-120/3000-S/S	95	78516	CST1HDM-G	94	78580	CART-48/1200-S/S	101
78355	PCAP-24/600-S/S	82	78383	SACPL2-120/3000-S/S	101	78517	SST1HDM-W	73	78581	CART-54/1350-S/S	79
78356	PCAP-30/750-S/S	82	78384	CSTHDMK-S/S	96	78517	SST1HDM-W	94	78581	CART-54/1350-S/S	81
78357	PCAP-36/900-S/S	82	78385	CTS-W-S/S	96	78518	SST1HDM-S	73	78581	CART-54/1350-S/S	86
78358	PCAP-42/1050-S/S	82	78386	CTS-S-S/S	96	78518	SST1HDM-S	94	78581	CART-54/1350-S/S	88
78359	PCAP-48/1200-S/S	82	78387	CTS-B-S/S	13	78519	SST1HDM-B	73	78581	CART-54/1350-S/S	93
78360	PCAP-54/1350-S/S	82	78387	CTS-B-S/S	96	78519	SST1HDM-B	94	78581	CART-54/1350-S/S	95
78361	PCAP-60/1500-S/S	82	78388	CTS-G-S/S	96	78537	MHS-600V-SAC-S/S	91	78581	CART-54/1350-S/S	100
78362	PCAP-72/1800-S/S	82	78389	CSTHDPM-S/S	96	78538	MHS-750V-SAC-S/S	91	78581	CART-54/1350-S/S	101
78363	RCAP-24/600-S/S	89	78390	CST1HDM-W-S/S	96	78539	MHS-900V-SAC-S/S	91	78582	CART-60/1500-S/S	47
78364	RCAP-30/750-S/S	89	78391	CST1HDM-S-S/S	96	78540	MHS-1050V-SAC-S/S	91	78582	CART-60/1500-S/S	53
78365	RCAP-36/900-S/S	89	78392	CST1HDM-B-S/S	96	78541	MHS-1200V-SAC-S/S	91	78582	CART-60/1500-S/S	79
78366	RCAP-42/1050-S/S	89	78393	CST1HDM-G-S/S	96	78542	MHS-1350V-SAC-S/S	91	78582	CART-60/1500-S/S	81
78367	RCAP-48/1200-S/S	89	78394	SST1HDM-W-S/S	73	78543	MHS-1500V-SAC-S/S	91	78582	CART-60/1500-S/S	86

INDEX By Item Code

Item Code	Ordering Number	Page #	Item Code	Ordering Number	Page #	Item Code	Ordering Number	Page #	Item Code	Ordering Number	Page #
78582	CART-60/1500-S/S	88	78635	CART2-78/1950-S/S	48	78923	EZP1MPK-S/S	18	79233	CCKHDS	71
78582	CART-60/1500-S/S	93	78635	CART2-78/1950-S/S	54	78933	LSTMPK-S/S	13	79234	CCKTS-S/S	64
78582	CART-60/1500-S/S	95	78635	CART2-78/1950-S/S	79	79009	HDRBK	121	79234	CCKTS-S/S	66
78582	CART-60/1500-S/S	100	78635	CART2-78/1950-S/S	81	79010	HDR24	121	79236	HDRGEK	121
78582	CART-60/1500-S/S	101	78635	CART2-78/1950-S/S	86	79011	HDR30	121	79267	PTP18R	154
78583	CART-72/1800-S/S	47	78635	CART2-78/1950-S/S	88	79012	HDR36	121	79268	PTP24R	154
78583	CART-72/1800-S/S	53	78635	CART2-78/1950-S/S	93	79013	HDR42	121	79269	PTP30R	154
78583	CART-72/1800-S/S	79	78635	CART2-78/1950-S/S	95	79014	HDR48	121	79270	PTP36R	154
78583	CART-72/1800-S/S	81	78635	CART2-78/1950-S/S	100	79015	HDR54	121	79271	PTP42R	154
78583	CART-72/1800-S/S	86	78635	CART2-78/1950-S/S	102	79016	HDR60	121	79272	PTP48R	154
78583	CART-72/1800-S/S	88	78639	CART2-114/2850-S/S	48	79017	HDRS72*	121	79273	PTP54R	154
78583	CART-72/1800-S/S	93	78639	CART2-114/2850-S/S	54	79018	HDRS84*	121	79274	PTP60R	154
78583	CART-72/1800-S/S	95	78640	CART2-126/3150-S/S	48	79019	HDRR24	121	79275	PTP72R	154
78583	CART-72/1800-S/S	100	78640	CART2-126/3150-S/S	54	79020	HDRR30	121	79276	PTPHD48R	154
78583	CART-72/1800-S/S	101	78642	SACPL2-78/1950-S/S	81	79021	HDRR36	121	79277	PTPHD54R	154
78584	CART2-60/1500-S/S	48	78642	SACPL2-78/1950-S/S	88	79022	HDRR42	121	79278	PTPHD60R	154
78584	CART2-60/1500-S/S	54	78642	SACPL2-78/1950-S/S	95	79023	HDRR48	121	79279	PTPHD72R	154
78584	CART2-60/1500-S/S	79	78642	SACPL2-78/1950-S/S	101	79024	HDRR54	121	79280	PTPHD84R	154
78584	CART2-60/1500-S/S	81	78649	MHS-1950V-2SAC-S/S	91	79025	HDRR60	121	79281	PTPHD96R	154
78584	CART2-60/1500-S/S	86	78649	MHS-1950BV-2SAC-S/S	98	79026	HDRS72*	121	79288	ESS-S-S/S	108
78584	CART2-60/1500-S/S	88	78656	PV1950-2SAC-S/S	77	79027	HDRS84*	121	79289	PFC-P-S/S	64
78584	CART2-60/1500-S/S	93	78663	RV1950-2SAC-S/S	84	79057	STS-G-S/S	55	79431	MSTHD-W	68
78584	CART2-60/1500-S/S	95	78683	PACB60	69	79057	STS-G-S/S	55	79432	MSTHD-S	68
78584	CART2-60/1500-S/S	100	78683	PACB60	74	79057	STS-G-S/S	68	79433	MSTHD-B	68
78584	CART2-60/1500-S/S	102	78683	PACB60	94	79069	SST1HDM-G	73	79434	MSTDB	69
78585	CART2-72/1800-S/S	48	78684	PAT1	29	79069	SST1HDM-G	94	79435	MSTAM	68
78585	CART2-72/1800-S/S	54	78685	PAT2	29	79070	SSTHK	73	79436	MST-MBL	69
78585	CART2-72/1800-S/S	79	79056	PSTS-S-S/S	55	79071	SSTHK-S/S	73	79437	MST-MBR	69
78585	CART2-72/1800-S/S	81	78789	SB4	127	79072	HDRBK-HD	121	79440	MSTBK	68
78585	CART2-72/1800-S/S	86	78789	SB4	129	79200	SPFC	68	79440	MSTBK	68
78585	CART2-72/1800-S/S	88	78789	SB4	131	79200	SPFC	71	79470	PTPLB	156
78585	CART2-72/1800-S/S	93	78789	SB4	133	79200	SPFC	73	79473	PTPLB-HD	156
78585	CART2-72/1800-S/S	95	78790	SB5	127	79200	SPFC	93	79476	PTP-RPA	156
78585	CART2-72/1800-S/S	100	78790	SB5	129	79200	SPFC	100	79478	PTP-HDRPA	156
78585	CART2-72/1800-S/S	102	78790	SB5	131	79201	SPFC-S/S	68	79484	PTP-EBKR	156
78586	CART2-84/2100-S/S	48	78790	SB5	133	79201	SPFC-S/S	71	79486	PTP-HDEBKR	156
78586	CART2-84/2100-S/S	54	78791	PATLK	29	79201	SPFC-S/S	73	79488	PTP-LS	156
78586	CART2-84/2100-S/S	79	78794	PATHK	29	79201	SPFC-S/S	96	79490	PTP-RMB	156
78586	CART2-84/2100-S/S	81	78808	EST-P-S/S	18	79201	SPFC-S/S	102	79491	PTP-RRB	156
78586	CART2-84/2100-S/S	86	78809	EST-W-S/S	18	79206	USPB2	107	79492	PTP-HDRBK	156
78586	CART2-84/2100-S/S	88	78810	EST-G-S/S	18	79206	USPB2	108	79494	MBC-18	111
78586	CART2-84/2100-S/S	93	78812	EZP1P12-S/S	18	79207	UHPB2	107	79495	MBC-24	111
78586	CART2-84/2100-S/S	95	78838	CFG-212	15	79207	UHPB2	108	79496	MBC-30	111
78586	CART2-84/2100-S/S	100	78839	CFG-218	15	79224	CCKL	64	79497	MBC-36	111
78586	CART2-84/2100-S/S	102	78840	CFG-224	15	79224	CCKL	66	79498	MBC-42	111
78587	CART2-96/2400-S/S	48	78841	CFG-230	15	79225	CCKHDL	64	79499	MBC-48	111
78587	CART2-96/2400-S/S	54	78842	CFG-236	15	79225	CCKHDL	66	79500	MBC-54	111
78587	CART2-96/2400-S/S	79	78843	CFG-242	15	79225	CCKHDL	71	79501	MBC-60	111
78587	CART2-96/2400-S/S	81	78844	CFG-248	15	79226	CCKL-S/S	64	79502	MBC-72	111
78587	CART2-96/2400-S/S	86	78845	CFG-254	15	79226	CCKL-S/S	66	79503	MBC-84	111
78587	CART2-96/2400-S/S	88	78846	CFG-260	15	79227	CCKHDL-S/S	64	79504	MBDS-18	113
78587	CART2-96/2400-S/S	93	78847	CFG-272	15	79227	CCKHDL-S/S	66	79505	MBDS-24	113
78587	CART2-96/2400-S/S	95	78848	EZP1PL-S/S	18	79227	CCKHDL-S/S	71	79506	MBDS-30	113
78587	CART2-96/2400-S/S	100	78849	ESTAK-EST-S/S	18	79228	CCKR	64	79507	MBDS-36	113
78587	CART2-96/2400-S/S	102	78849	ESTAK-EST-S/S	55	79228	CCKR	66	79508	MBDS-42	113
78588	CART2-120/3000-S/S	48	78849	ESTAK-SS	108	79229	CCKHDR	64	79509	MBDS-48	113
78588	CART2-120/3000-S/S	54	78850	LS-SW-S/S	13	79229	CCKHDR	66	79510	MBDS-54	113
78588	CART2-120/3000-S/S	79	78919	CCMK	64	79229	CCKHDR	71	79511	MBDS-60	113
78588	CART2-120/3000-S/S	81	78919	CCMK	66	79230	CCKR-S/S	64	79512	MBDS-72	113
78588	CART2-120/3000-S/S	86	78920	CCMKHD	64	79230	CCKR-S/S	66	79513	MBDS-84	113
78588	CART2-120/3000-S/S	88	78920	CCMKHD	66	79231	CCKHDR-S/S	64	79514	MBRD-18	111
78588	CART2-120/3000-S/S	93	78920	CCMKHD	71	79231	CCKHDR-S/S	66	79514	MBRD-18	113
78588	CART2-120/3000-S/S	95	78921	CCMK-S/S	64	79231	CCKHDR-S/S	71	79515	MBRD-24	111
78588	CART2-120/3000-S/S	100	78921	CCMK-S/S	66	79232	CCKTS	64	79515	MBRD-24	113
78588	CART2-120/3000-S/S	102	78922	CCMKHD-S/S	64	79232	CCKTS	66	79516	MBRD-30	111
78634	CART2-66/1650-S/S	48	78922	CCMKHD-S/S	66	79233	CCKHDS	64	79516	MBRD-30	113
78634	CART2-66/1650-S/S	54	78922	CCMKHD-S/S	71	79233	CCKHDS	66	79517	MBRD-36	111

INDEX By Item Code

Item Code	Ordering Number	Page #	Item Code	Ordering Number	Page #	Item Code	Ordering Number	Page #	Item Code	Ordering Number	Page #
79517	MBRD-36	113	79833	YCART-60/1500-HDTC	58	82215	EZSB1500-1500I	128	82348	EZWPK-1050	127
79518	MBRD-42	111	79834	YCART-72/1800-HDTC	58	82216	EZSB1800-1500I	128	82348	EZWPK-1050	129
79518	MBRD-42	113	79835	YTACHD	62	82217	EZIB600-1200L	130	82348	EZWPK-1050	131
79519	MBRD-48	111	79836	YST-Y	61	82218	EZIB750-1200L	130	82348	EZWPK-1050	133
79519	MBRD-48	113	79837	YST-P	61	82219	EZIB900-1200L	130	82349	EZWPK-1200	127
79520	MBRD-54	111	79838	YST-S	61	82220	EZIB1050-1200L	130	82349	EZWPK-1200	129
79520	MBRD-54	113	79839	YSTHD-GR	62	82221	EZIB1200-1200L	130	82349	EZWPK-1200	131
79521	MBRD-60	111	79840	YSTHD-S	62	82222	EZIB1350-1200L	130	82349	EZWPK-1200	133
79521	MBRD-60	113	79841	YSTHD-BL	62	82223	EZIB1500-1200L	130	82350	EZWPK-1350	127
79522	MBRD-72	111	79842	YSTHD-BK	62	82224	EZIB1800-1200L	130	82350	EZWPK-1350	129
79522	MBRD-72	113	79843	YSTMB	61	82225	EZIB600-1500L	130	82350	EZWPK-1350	131
79523	MBRD-84	111	79844	YSTDBK	61	82226	EZIB750-1500L	130	82350	EZWPK-1350	133
79523	MBRD-84	113	79845	YSTGBK	61	82227	EZIB900-1500L	130	82351	EZWPK-1500	127
79524	MBCMK	113	79846	YSTLBK	61	82228	EZIB1050-1500L	130	82351	EZWPK-1500	129
79525	MBCBC	113	79847	YSTTBK-W	61	82229	EZIB1200-1500L	130	82351	EZWPK-1500	131
79526	MBCB	113	79848	YSTPMK	61	82230	EZIB1350-1500L	130	82351	EZWPK-1500	133
79527	MBADB	113	79849	YSTHDMB	62	82231	EZIB1500-1500L	130	82352	EZWPK-1800	127
79528	MBCBM	113	79850	YSTHDDBK	62	82232	EZIB1800-1500L	130	82352	EZWPK-1800	129
79529	MBCM-1	113	79851	YSTHDGBK	62	82233	EZIB600-1200M	132	82352	EZWPK-1800	131
79530	MBCM-2	113	79852	YSTHDLBK	62	82234	EZIB750-1200M	132	82352	EZWPK-1800	133
79531	MBCTA	113	79853	YSTHDBK-W	62	82235	EZIB900-1200M	132	82353	EZCSK-600	127
79532	MBCBL	113	79854	YSTPHDMK	62	82236	EZIB1050-1200M	132	82353	EZCSK-600	129
79533	MBCMCK	113	79855	YSTTBK-B	61	82237	EZIB1200-1200M	132	82353	EZCSK-600	131
79534	MBCEC	113	79856	YSTHDBK-B	62	82238	EZIB1350-1200M	132	82353	EZCSK-600	133
79535	STLP	113	79857	YSTANK	61	82239	EZIB1500-1200M	132	82354	EZCSK-750	127
79536	MBCDBK	111	79858	YSTANK	62	82240	EZIB1800-1200M	132	82354	EZCSK-750	129
79536	MBCDBK	113	81045	C-PSTA	107	82241	EZIB600-1500M	132	82354	EZCSK-750	131
79573	YT-P*	58	81250	RIBBK	127	82242	EZIB750-1500M	132	82354	EZCSK-750	133
79574	YT-C*	58	81250	RIBBK	129	82243	EZIB900-1500M	132	82355	EZCSK-900	127
79617	YCART-18/450-P	58	81250	RIBBK	131	82244	EZIB1050-1500M	132	82355	EZCSK-900	129
79618	YCART-24/600-P	58	81250	RIBBK	133	82245	EZIB1200-1500M	132	82355	EZCSK-900	131
79619	YCART-30/750-P	58	81896	MESPKR	107	82246	EZIB1350-1500M	132	82355	EZCSK-900	133
79620	YCART-36/900-P	58	82174	QMTBK-GCN	107	82247	EZIB1500-1500M	132	82356	EZCSK-1050	127
79621	YCART-42/1050-P	58	82174	QMTBK-GCN	108	82248	EZIB1800-1500M	132	82356	EZCSK-1050	129
79622	YCART-48/1200-P	58	82175	QMTBK-WS-MT	107	82281	EZBMK-600	131	82356	EZCSK-1050	131
79623	YTAC	61	82175	QMTBK-WS-MT	108	82281	EZBMK-600	133	82356	EZCSK-1050	133
79656	PACB100	69	82182	QMTPSBK-CN	107	82282	EZBMK-750	131	82357	EZCSK-1200	127
79656	PACB100	74	82185	EZSB600-1200C	126	82282	EZBMK-750	133	82357	EZCSK-1200	129
79656	PACB100	94	82186	EZSB750-1200C	126	82283	EZBMK-900	131	82357	EZCSK-1200	131
79677	YT-HDP*	58	82187	EZSB900-1200C	126	82283	EZBMK-900	133	82357	EZCSK-1200	133
79728	YT-HDC*	58	82188	EZSB1050-1200C	126	82284	EZBMK-1050	131	82358	EZCSK-1350	127
79795	YSTS-Y	61	82189	EZSB1200-1200C	126	82284	EZBMK-1050	133	82358	EZCSK-1350	129
79796	YSTS-P	61	82190	EZSB1350-1200C	126	82285	EZBMK-1200	131	82358	EZCSK-1350	131
79797	YSTHDS-GR	62	82191	EZSB1500-1200C	126	82285	EZBMK-1200	133	82358	EZCSK-1350	133
79798	YSTHDS-BL	62	82192	EZSB1800-1200C	126	82286	EZBMK-1350	131	82359	EZCSK-1500	127
79805	YTAHD-36/900	62	82193	EZSB600-1500C	126	82286	EZBMK-1350	133	82359	EZCSK-1500	129
79806	YTAHD-42/1050	62	82194	EZSB750-1500C	126	82287	EZBMK-1500	131	82359	EZCSK-1500	131
79807	YTAHD-48/1200	62	82195	EZSB900-1500C	126	82287	EZBMK-1500	133	82359	EZCSK-1500	133
79808	YTAHD-54/1350	62	82196	EZSB1050-1500C	126	82288	EZBMK-1800	131	82360	EZCSK-1800	127
79809	YTAHD-60/1500	62	82197	EZSB1200-1500C	126	82288	EZBMK-1800	133	82360	EZCSK-1800	129
79810	YTAHD-72/1800	62	82198	EZSB1350-1500C	126	82289	MPSTA-S/S	108	82360	EZCSK-1800	131
79811	YCART-18/450-TC	58	82199	EZSB1500-1500C	126	82342	PTPK-MT-S/S	108	82360	EZCSK-1800	133
79812	YCART-24/600-TC	58	82200	EZSB1800-1500C	126	82343	PTPK-MT	107	82361	EZBS-1200	131
79813	YCART-30/750-TC	58	82201	EZSB600-1200I	128	82344	EZRMKM	127	82362	EZBS-1500	131
79814	YCART-36/900-TC	58	82202	EZSB750-1200I	128	82344	EZRMKM	129	82364	MESBK-PS	107
79815	YCART-42/1050-TC	58	82203	EZSB900-1200I	128	82345	EZWPK-600	127	82364	MESBK-PS	108
79816	YCART-48/1200-TC	58	82204	EZSB1050-1200I	128	82345	EZWPK-600	129	82393	SHIM-LDKIT	127
79817	YCART-36/900-HDP	58	82205	EZSB1200-1200I	128	82345	EZWPK-600	131	82393	SHIM-LDKIT	129
79818	YCART-42/1050-HDP	58	82206	EZSB1350-1200I	128	82345	EZWPK-600	133	82393	SHIM-LDKIT	131
79819	YCART-48/1200-HDP	58	82207	EZSB1500-1200I	128	82346	EZWPK-750	127	82394	SHIM-MDKIT	133
79820	YCART-54/1350-HDP	58	82208	EZSB1800-1200I	128	82346	EZWPK-750	129	82397	IBS-M1200	133
79821	YCART-60/1500-HDP	58	82209	EZSB600-1500I	128	82346	EZWPK-750	131	82398	IBS-M1500	133
79822	YCART-72/1800-HDP	58	82210	EZSB750-1500I	128	82346	EZWPK-750	133	82410	EZAI-600	126
79829	YCART-36/900-HDTC	58	82211	EZSB900-1500I	128	82347	EZWPK-900	127	82411	EZAI-750	126
79830	YCART-42/1050-HDTC	58	82212	EZSB1050-1500I	128	82347	EZWPK-900	129	82412	EZAI-900	126
79831	YCART-48/1200-HDTC	58	82213	EZSB1200-1500I	128	82347	EZWPK-900	131	82413	EZAI-1050	126
79832	YCART-54/1350-HDTC	58	82214	EZSB1350-1500I	128	82347	EZWPK-900	133	82414	EZAI-1200	126

INDEX By Item Code

Item Code	Ordering Number	Page #	Item Code	Ordering Number	Page #	Item Code	Ordering Number	Page #	Item Code	Ordering Number	Page #
82415	EZAI-1350	126	82831	R-CARK-V42/1050-S/S RVECKS/S	85	82888	USPK-SS-M	108	83243	YT-TC-750S	56
82416	EZAI-1500	126				82889	UHSPK-SS-M	108	83244	YT-TC-900S	56
82417	EZAI-1800	126	82832	R-CARK-V48/1200-S/S RVECKS/S	85	82890	UMBK-M	107	83245	YT-TC-1050S	56
82689	USP18/450	107	82833	R-CARK-V54/1350-S/S RVECKS/S	85	82891	UMBK-SS-M	108	83246	YT-TC-1200S	56
82690	USP24/600	107				82892	MESPBL-SS	108	87895	MESPBL	107
82691	USP30/750	107	82834	R-CARK-V60/1500-S/S RVECKS/S	85	82893	MUPSBK-SS	108	90181	MSTHD-SS-W	68
82692	USP36/900	107				82894	MESPKR-SS	108	90182	MSTHD-SS-S	68
82693	USP42/1050	107	82835	R-CARK-V72/1800-S/S RVECKS/S	85	82895	MQMTSBK-SS	108	90183	MSTHD-SS-B	68
82694	USP48/1200	107				82896	MUPSBK	107	90184	MSTHD-SS-G	68
82695	USP54/1350	107	82836	R-CARK2-V60/1500-S/S RV2ECKSS	85	82897	UST-P-MT	107	90265	PTEZ-450	149
82696	USP56/1400	107				82898	UST-S-MT	107	90266	PTEZ-600	149
82697	USP60/1500	107	82837	R-CARK2-V72/1800-S/S RV2ECKSS	85	82899	UST-W-MT	107	90267	PTEZ-750	149
82698	USP64/1600	107				82900	UST-G-MT	107	90268	PTEZ-900	149
82699	USP72/1800	107	82838	R-CARK2-V84/2100-S/S RV2ECKSS	85	82901	UST-P-MT-SS	108	90269	PTEZ-1050	149
82700	USP80/2000	107				82902	UST-S-MT-SS	108	90270	PTEZ-1200	149
82701	USP84/2100	107	82839	R-CARK2-V96/2400-S/S RV2ECKSS	85	82903	UST-W-MT-SS	108	90283	SKPU-6x1/2x25	161
82702	USP88/2200	107				82904	UST-G-MT-SS	108	90284	SKPU-6x3/4x25	161
82703	USP94/2400	107	82840	R-CARK2-V120/3000-S/S RV2ECKSS	85	82932	YTP-18/450	61	90285	SKPU-6x1/2x25	161
82704	USP98/2500	107				82933	YTP-24/600	61	90286	SKPU-6x3/4x25	161
82707	UTV450-S/S	105	82841	MHS-CARK-V24/600-S/S MVECKS/S	92	82934	YTP-30/750	61	90351	PTEZMB	149
82708	UTV600-S/S	105				82935	YTP-36/900	61	90352	PTEZPB	149
82709	UTV750-S/S	105	82841	MHS-CARK-V24/600-S/S MVECKS/S	99	82936	YTP-42/1050	61	90353	PTEZDC	149
82710	UTV900-S/S	105	82842	MHS-CARK-V30/750-S/S MVECKS/S	92	82937	YTP-48/1200	61	A1854	CBD-M-S/S	145
82711	UTV1050-S/S	105				82949	YTA-18/450	61	A1856	CBD-L-S/S	145
82712	UTV1200-S/S	105	82842	MHS-CARK-V30/750-S/S MVECKS/S	99	82950	YTA-24/600	61	A0012	WCB	118
82713	UTV1350-S/S	105				82951	YTA-30/750	61	A0012	WCB	119
82714	UTV1400-S/S	105	82843	MHS-CARK-V36/900-S/S MVECKS/S	92	82952	YTA-36/900	61	A0151	HBP2600-PL-TP	144
82715	UTV1500-S/S	105				82953	YTA-42/1050	61	A0223	BP750-HD-B	140
82716	UTV1600-S/S	105	82843	MHS-CARK-V36/900-S/S MVECKS/S	99	82954	YTA-48/1200	61	A0224	BP900-HD-B	140
82717	UTV1800-S/S	105				83099	YTCHD-900	57	A0235	PTMSR	157
82718	UTV2000-S/S	105	82844	MHS-CARK-V42/1050-S/S MVECKS/S	92	83100	YTCHD-1050	57	A0316	SB1200A	118
82719	UTV2100-S/S	105				83101	YTCHD-1200	57	A0407	SB750A	118
82720	UTV2200-S/S	105	82844	MHS-CARK-V42/1050-S/S MVECKS/S	99	83102	YTCHD-1350	57	A0435	SB1050A	118
82721	UTV2400-S/S	105				83103	YTCHD-1500	57	A0613	BP800-1050-PL-S/S	140
82722	UTV2500-S/S	105	82845	MHS-CARK-V48/1200-S/S MVECKS/S	92	83105	YTCHD-1800	57	A0614	BP-LA-S/S	140
82810	SCU60-S/S	108				83106	YTPHD-36/900	62	A0615	BP-MB-S/S	140
82811	SCUHD-S/S	108	82845	MHS-CARK-V48/1200-S/S MVECKS/S	99	83107	YTPHD-42/1050	62	A0616	BP-SC-S/S	140
82812	SCU60	107				83108	YTPHD-48/1200	62	A0617	BP-TL-S/S	140
82813	SCUHD	107	82846	MHS-CARK-V54/1350-S/S MVECKS/S	92	83109	YTPHD-54/1350	62	A0621	BP1200-1400-PL-S/S	140
82815	P-CARK-V24/600-S/S PVECKS/S	78				83110	YTPHD-60/1500	62	A0647	BP1500-1600-PL-S/S	140
82816	P-CARK-V30/750-S/S PVECKS/S	78	82847	MHS-CARK-V60/1500-S/S MVECKS/S	92	83112	YTPHD-72/1800	62	A0683	BP450-750-PL-S/S	140
82817	P-CARK-V36/900-S/S PVECKS/S	78				83120	YTHD-900S	57	A0887	SB600A	118
82818	P-CARK-V42/1050-S/S PVECKS/S	78	82847	MHS-CARK-V60/1500-S/S MVECKS/S	99	83121	YTHD-1050S	57	A0912	SB900A	118
82819	P-CARK-V48/1200-S/S PVECKS/S	78				83122	YTHD-1200S	57	A1155	HBP-MB-TP-S/S	142
82820	P-CARK-V54/1350-S/S PVECKS/S	78	82848	MHS-CARK-V72/1800-S/S MVECKS/S	92	83123	YTHD-1350S	57	A1155	HBP-MB-TP-S/S	144
82821	P-CARK-V60/1500-S/S PVECKS/S	78				83124	YTHD-1500S	57	A1357	SB1800A	118
82822	P-CARK-V72/1800-S/S PVECKS/S	78	82848	MHS-CARK-V72/1800-S/S MVECKS/S	99	83126	YTHD-1800S	57	A1436	FLSC2000-S/S	160
82823	P-CARK2-V60/1500-S/S PV2ECKSS	78				83134	YTHD-TC-900S	57	A1437	FLSC-TP-S/S	160
82824	P-CARK2-V72/1800-S/S PV2ECKSS	78	82849	MHS-CARK2-V60/1500-S/S MV2CKSS	92	83135	YTHD-TC-1050S	57	A1438	FLSC-CP-S/S	160
82825	P-CARK2-V84/2100-S/S PV2ECKSS	78				83136	YTHD-TC-1200S	57	A1439	FLSC2000-CB-S/S	160
82826	P-CARK2-V96/2400-S/S PV2ECKSS	78	82849	MHS-CARK2-V60/1500-S/S MV2CKSS	99	83137	YTHD-TC-1350S	57	A1440	FLSC2000-MC-S/S	160
82827	P-CARK2-V120/3000-S/S PV2ECKSS	78				83138	YTHD-TC-1500S	57	A1547	BP1800-PL-S/S	140
82828	R-CARK-V24/600-S/S RVECKS/S	85	82850	MHS-CARK2-V72/1800-S/S MV2CKSS	92	83140	YTHD-TC-1800S	57	A1575	RPHD1800-S/S	66
82829	R-CARK-V30/750-S/S RVECKS/S	85				83223	YTC-450	56	A1588	HXFHD1800M-S/S	37
82830	R-CARK-V36/900-S/S RVECKS/S	85	82851	MHS-CARK2-V72/1800-S/S MV2CKSS	99	83224	YTC-600	56	A1589	HXFHD1800L-S/S	37
						83225	YTC-750	56	A1590	HXFHD2100M-S/S	37
			82851	MHS-CARK2-V84/2100-S/S MV2CKSS	99	83226	YTC-900	56	A1591	HXFHD2100L-S/S	37
						83227	YTC-1050	56	A1592	HXFHD2400M-S/S	37
			82852	MHS-CARK2-V84/2100-S/S MV2CKSS	99	83228	YTC-1200	56	A1593	HXFHD2400L-S/S	37
						83229	YT-450S	56	A1594	HVHD1800M-S/S	39
			82852	MHS-CARK2-V96/2400-S/S MV2CKSS	92	83230	YT-600S	56	A1595	HVHD1800L-S/S	39
						83231	YT-750S	56	A1596	HVHD1800LL-S/S	39
			82853	MHS-CARK2-V96/2400-S/S MV2CKSS	99	83232	YT-900S	56	A1597	HVHD2100M-S/S	39
						83233	YT-1050S	56	A1598	HVHD2100L-S/S	39
			82853	MHS-CARK2-V120/3000-S/S MV2CKS	92	83234	YT-1200S	56	A1599	HVHD2100LL-S/S	39
						83241	YT-TC-450S	56	A1600	HVHD2400M-S/S	39
			82876	P-CARK2-V78/1950-S/S PV2ECKSS	78	83242	YT-TC-600S	56	A1601	HVHD2400L-S/S	39
			82887	UHSPK-M	107						

INDEX By Item Code

Item Code	Ordering Number	Page #	Item Code	Ordering Number	Page #	Item Code	Ordering Number	Page #	Item Code	Ordering Number	Page #
A1602	HVHD2400LL-S/S	39	A2306	HBP1050-MF-TP	142	A2508	HBP1500-MF-TP-S/S	142	PTM-1600-3		157
A1603	PVHD1800-S/S	63	A2307	HBP1200-MF-TP	142	A2509	HBP1600-MF-TP-S/S	142	PTM-1800-3		157
A1604	PVHD2100-S/S	63	A2308	HBP1400-MF-TP	142	A2510	HBP1800-MF-TP-S/S	142	PTM-2000-3		157
A1605	PVHD2400-S/S	63	A2309	HBP1500-MF-TP	142	A2511	HBP2000-MF-TP-S/S	142	PTM-2400-3		157
A1610	RVHD2400-S/S	65	A2310	HBP1600-MF-TP	142	A2512	HBP2200-MF-TP-S/S	142	PTM-2600-3		157
A1613	PPHD2100-S/S	64	A2311	HBP1800-MF-TP	142	A2513	HBP2400-MF-TP-S/S	142	PTM-3000-3		157
A1620	SB1400A	118	A2312	HBP2000-MF-TP	142	A2514	HBP2500-MF-TP-S/S	142	PTM-750-1		157
A1622	RBPRET	148	A2313	HBP2400-MF-TP	142	A2515	HBP-LA-TP-S/S	142	PTM-900-1		157
A1626	RVHD1800-S/S	65	A2314	HBP2200-MF-TP	142	A2518	HDSTKD	42	PTM-1050-1		157
A1628	RVHD2100-S/S	65	A2315	HBP2500-MF-TP	142	A2519	HDSTKD-S/S	42	PTM-1200-1		157
A1629	RPHD2100-S/S	66	A2316	HBP900-B-TP	142	A2527	RPHD2100	66	PTM-1350-1		157
A1775	PPHD2400-S/S	64	A2317	HBP1050-B-TP	142	A2590	HPHD2400-S/S	42	PTM-1500-1		157
A1781	PPHD1800-S/S	64	A2318	HBP1200-B-TP	142	a2596	FLSCM-CP-S/S	160	PTM-1600-1		157
A1783	HPHD2000-S/S	42	A2319	HBP1400-B-TP	142	A2629	CBD-ST-TB-S/S	146	PTM-1800-1		157
A1784	CBD-ST-XL-B	146	A2320	HBP1500-B-TP	142	A2629	CBD-ST-TB-S/S	146	PTM-2000-1		157
A1784	CBD-ST-XL-B	146	A2321	HBP1600-B-TP	142	A2630	CBD-ST-MC	146	PTM-2400-1		157
A1838	SB1500A	118	A2322	HBP1800-B-TP	142	A2671	UNB73	42	PTM-2600-1		157
A2046	PVHD2000-S/S	63	A2323	HBP2000-B-TP	142	A2803	PPHD2100	64	PTM-3000-1		157
A2063	HPHD1800-S/S	42	A2324	HBP2400-B-TP	142	A2825	CRDLBLK-RH-S/S	82	PTM-750-2		157
A2120	PPHD2000-S/S	64	A2325	HBP2200-B-TP	142	A2825	CRDLBLK-RH-S/S	89	PTM-900-2		157
A2138	CBD-ST-XL-S/S	146	A2326	HBP2500-B-TP	142	A2825	CRDLBLK-RH-S/S	102	PTM-1050-2		157
A2189	HDSTCK-S/S	42	A2330	HBP-LA-TP	142	A2826	CRDLBLK-LH-S/S	82	PTM-1200-2		157
A2189	HBP-SC-TP-S/S	142	A2449	CBD-ST-PB	146	A2826	CRDLBLK-LH-S/S	89	PTM-1350-2		157
A2215	CBD-ST-CS-S/S	146	A2449	CBD-ST-PB	146	A2826	CRDLBLK-LH-S/S	102	PTM-1500-2		157
A2215	CBD-ST-CS-S/S	146	A2462	HVHD2600M-S/S	39	A2829	MR-1500PG	120	PTM-1600-2		157
A2218	CBD-ST-L-B	146	A2474	HBP-TP-900 S/S	141	A2830	MR-1600PG	120	PTM-1800-2		157
A2218	CBD-ST-L-B	146	A2475	HBP-TP-1050 S/S	141	A2831	MR-1800PG	120	PTM-2000-2		157
A2237	BP1050-HD-B	140	A2476	HBP-TP-1200 S/S	141	A2832	MR-2100PG	120	PTM-2400-2		157
A2283	HBP900-TP	141	A2477	HBP-TP-1400 S/S	141	A2833	MR-2400PG	120	PTM-2600-2		157
A2284	HBP1050-TP	141	A2478	HBP-TP-1500 S/S	141	A2834	MR-2600PG	120	PTM-3000-2		157
A2285	HBP1200-TP	141	A2479	HBP-TP-1600 S/S	141	A2835	MR-3000PG	120	PTM-750-3-S/S		158
A2286	HBP1400-TP	141	A2480	HBP-TP-1800 S/S	141	A2836	MR-450PG	120	PTM-900-3-S/S		158
A2287	HBP1500-TP	141	A2481	HBP-TP-2000 S/S	141	A2837	MR-600PG	120	PTM-1050-3-S/S		158
A2288	HBP1600-TP	141	A2482	HBP-TP-2200 S/S	141	A2838	MR-750PG	120	PTM-1200-3-S/S		158
A2289	HBP1800-TP	141	A2483	HBP-TP-2400 S/S	141	A2839	MR-900PG	120	PTM-1350-3-S/S		158
A2290	HBP2000-TP	141	A2484	HBP-TP-2500 S/S	141	A2840	MR-1050PG	120	PTM-1600-3-S/S		158
A2291	HBP2200-TP	141	A2492	HBP900-PL-TP-S/S	142	A2841	MR-1200PG	120	PTM-1800-3-S/S		158
A2292	HBP2400-TP	141	A2492	HBP900-PL-TP-S/S	144	A2842	SMR-CCB-L73	80	PTM-2000-3-S/S		158
A2293	HBP2500-TP	141	A2493	HBP1050-PL-TP-S/S	142	A2842	SMR-CCB-L73	87	PTM-2400-3-S/S		158
A2294	HBP900-PL-TP	142	A2493	HBP1050-PL-TP-S/S	144	A2842	SMR-CCB-L73	100	PTM-2600-3-S/S		158
A2294	HBP900-PL-TP	144	A2494	HBP1200-PL-TP-S/S	142	A2842	SMR-CCB-L73	120	PTM-3000-3-S/S		158
A2295	HBP1050-PL-TP	142	A2494	HBP1200-PL-TP-S/S	144	A2843	SMR-CCB-R73	80	PTM-750-1-S/S		158
A2295	HBP1050-PL-TP	144	A2495	HBP1400-PL-TP-S/S	142	A2843	SMR-CCB-R73	87	PTM-900-1-S/S		158
A2296	HBP1200-PL-TP	142	A2495	HBP1400-PL-TP-S/S	144	A2843	SMR-CCB-R73	100	PTM-1050-1-S/S		158
A2296	HBP1200-PL-TP	144	A2496	HBP1500-PL-TP-S/S	142	A2843	SMR-CCB-R73	120	PTM-1200-1-S/S		158
A2297	HBP1400-PL-TP	142	A2496	HBP1500-PL-TP-S/S	144	A2844	SMR-CCB-L60	120	PTM-1350-1-S/S		158
A2297	HBP1400-PL-TP	144	A2497	HBP1600-PL-TP-S/S	142	A2845	SMR-CCB-R60	120	PTM-1600-1-S/S		158
A2298	HBP1500-PL-TP	142	A2497	HBP1600-PL-TP-S/S	144	A2988	EZP1P24-S/S	18	PTM-1800-1-S/S		158
A2298	HBP1500-PL-TP	144	A2498	HBP1800-PL-TP-S/S	142	A3041	EZP1P30-S/S	18	PTM-2000-1-S/S		158
A2299	HBP1600-PL-TP	142	A2498	HBP1800-PL-TP-S/S	144	A3119	EZP1P36-S/S	18	PTM-2400-1-S/S		158
A2299	HBP1600-PL-TP	144	A2499	HBP2000-PL-TP-S/S	142	B0092	CBD-ST-MC	146	PTM-2600-1-S/S		158
A2300	HBP1800-PL-TP	142	A2499	HBP2000-PL-TP-S/S	144	C7673	MSR-S/S	158	PTM-3000-1-S/S		158
A2300	HBP1800-PL-TP	144	A2500	HBP2200-PL-TP-S/S	142	G1211	HEX NUT	55	PTM-750-2-S/S		158
A2301	HBP2000-PL-TP	142	A2500	HBP2200-PL-TP-S/S	144	G1211	HEX NUT	69	PTM-900-2-S/S		158
A2301	HBP2000-PL-TP	144	A2501	HBP2400-PL-TP-S/S	142	G1211	HEX NUT	74	PTM-1050-2-S/S		158
A2302	HBP2400-PL-TP	142	A2501	HBP2400-PL-TP-S/S	144	G1211	HEX NUT	94	PTM-1200-2-S/S		158
A2302	HBP2400-PL-TP	144	A2502	HBP2500-PL-TP-S/S	142		PTM-750-3	157	PTM-1350-2-S/S		158
A2303	HBP2200-PL-TP	142	A2502	HBP2500-PL-TP-S/S	144		PTM-900-3	157	PTM-1600-2-S/S		158
A2303	HBP2200-PL-TP	144	A2504	HBP900-MF-TP-S/S	142		PTM-1050-3	157	PTM-1800-2-S/S		158
A2304	HBP2500-PL-TP	142	A2505	HBP1050-MF-TP-S/S	142		PTM-1200-3	157	PTM-2000-2-S/S		158
A2304	HBP2500-PL-TP	144	A2506	HBP1200-MF-TP-S/S	142		PTM-1350-3	157	PTM-2400-2-S/S		158
A2305	HBP900-MF-TP	142	A2507	HBP1400-MF-TP-S/S	142		PTM-1500-3	157	PTM-2600-2-S/S		158
									PTM-3000-2-S/S		158



Partners in Productivity

10 Solent Circuit

Baulkham Hills NSW 2153

Phone: +61 2-8818-2000 Fax: +61 2-8824-6333

Toll Free: 1300 098 435

E-mail: salesau@flexco.com

www.flexco.com