

CBS

Continuous Blade Secondary Belt Cleaner

A Clean Belt is Just Beyond This Rugged Blade

The CBS Continuous Blade Secondary Belt Cleaner is designed with an unsegmented blade for excellent cleaning efficiency and low maintenance. The heavy-duty blade features a steel backbone holding a carbide leading edge which is encapsulated in our proprietary polyurethane to provide a long-wearing solution for your belt. When paired with a spring or air tensioner, the blade maintains constant pressure on the belt for excellent cleaning efficiency.

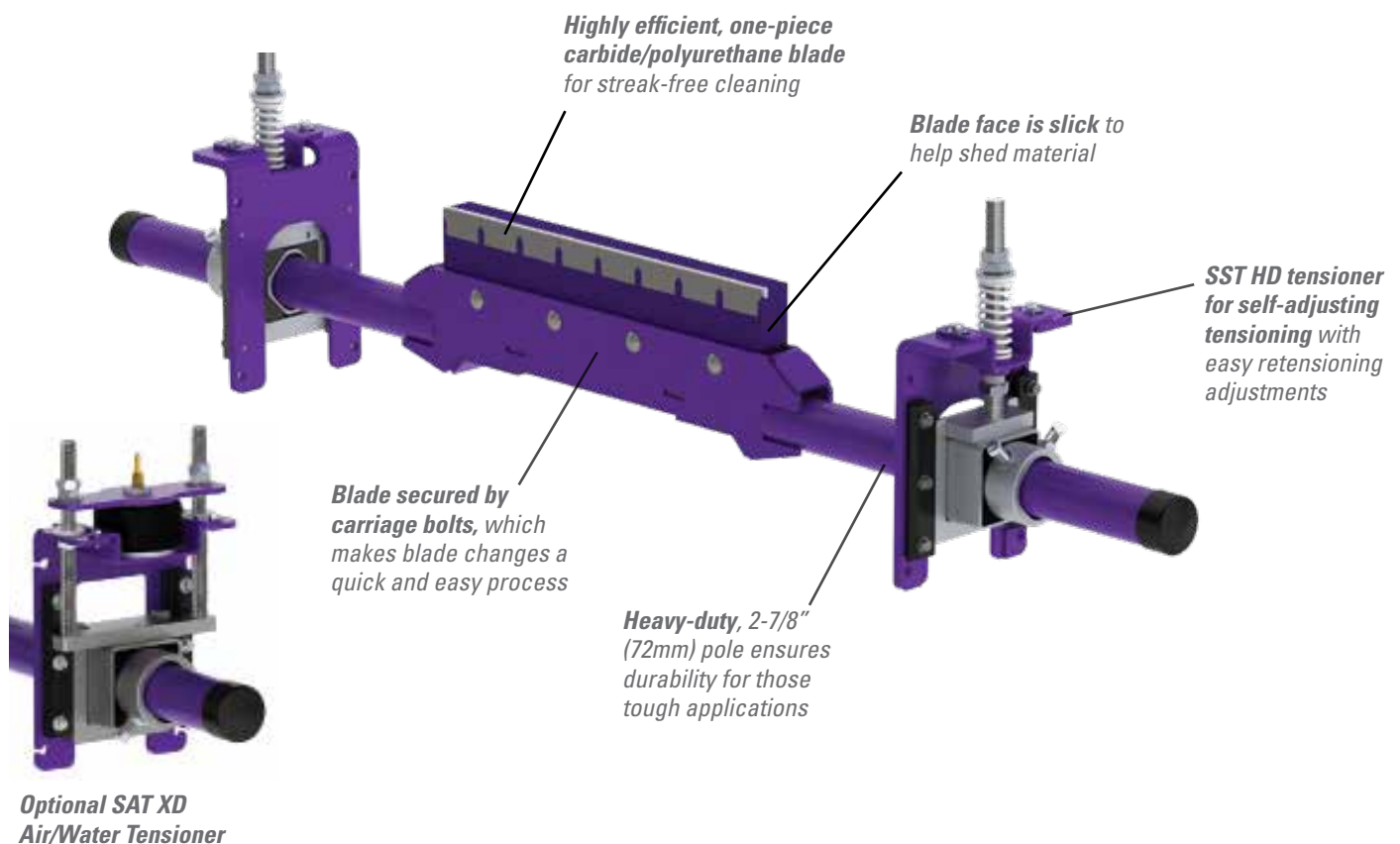

Features and Benefits

- **Cleaning efficiency of a metal blade.** The thin, hard edge of the metal blade delivers high cleaning efficiency and long wear life.
- **A complete cleaning system.** When the CBS is teamed with the MMP precleaner the system provides maximum cleaning power for tough applications.
- **Made for mining conveyors.** Made from heavy-duty, corrosion-resistant steel, the CBS is available in sizes for belt widths from 18" to 96" (450 to 2400mm). Additional sizes are available upon request.
- **Safe to service.** All service can be performed from a safe position at the side of the conveyor.

CBS Continuous Blade Secondary Belt Cleaner

Specifications and Guidelines

Maximum Belt Speed

800 FPM (4 M/sec)

Temperature Rating

-30° F to 180° F (-35° C to 82° C)

Blade Material

1/4" (6mm) thick highly efficient one-piece carbide/
polyurethane blade

Available for Belt Widths

18" to 96" (450 to 2400mm)

CEMA Cleaner Rating

Class 4

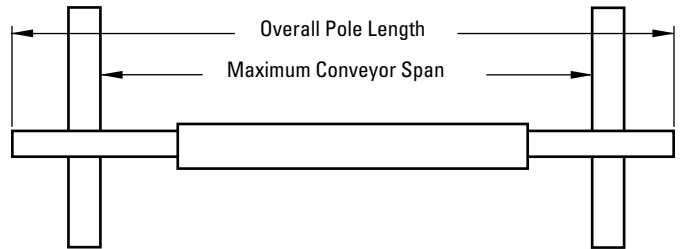

Pole Length Cleaner size + 54" (1350mm)

Maximum Conveyor Span Cleaner size + 44" (1100mm)

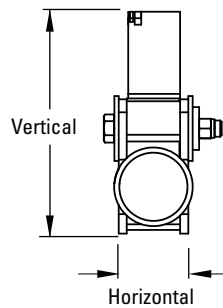

Horizontal Clearance Required

4 1/2" (115mm)

Vertical Clearance Required

9" (229mm)

Ordering Information

| CBS with SST Tensioners | | | |
|-------------------------|----------|---------|-------|
| Belt Width | Ordering | Item | |
| in. | mm | Number | Code |
| 18 | 450 | CBS18SF | 79936 |
| 24 | 600 | CBS24SF | 79937 |
| 30 | 750 | CBS30SF | 79938 |
| 36 | 900 | CBS36SF | 79939 |
| 42 | 1050 | CBS42SF | 79940 |
| 48 | 1200 | CBS48SF | 79941 |
| 54 | 1350 | CBS54SF | 79942 |
| 60 | 1500 | CBS60SF | 79943 |
| 72 | 1800 | CBS72SF | 79944 |
| 84 | 2100 | CBS84SF | 79945 |
| 96 | 2400 | CBS96SF | 79946 |

| CBS with SAT2 Tensioners | | | |
|--------------------------|----------|---------|-------|
| Belt Width | Ordering | Item | |
| in. | mm | Number | Code |
| 18 | 450 | CBS18PF | 79958 |
| 24 | 600 | CBS24PF | 79959 |
| 30 | 750 | CBS30PF | 79960 |
| 36 | 900 | CBS36PF | 79961 |
| 42 | 1050 | CBS42PF | 79962 |
| 48 | 1200 | CBS48PF | 79963 |
| 54 | 1350 | CBS54PF | 79964 |
| 60 | 1500 | CBS60PF | 79965 |
| 72 | 1800 | CBS72PF | 79966 |
| 84 | 2100 | CBS84PF | 79967 |
| 96 | 2400 | CBS96PF | 79968 |

| CBS Replacement Blades | | | |
|------------------------|----------|-----------|-------|
| Belt Width | Ordering | Item | |
| in. | mm | Number | Code |
| 18 | 450 | CBSBLD18F | 79947 |
| 24 | 600 | CBSBLD24F | 79948 |
| 30 | 750 | CBSBLD30F | 79949 |
| 36 | 900 | CBSBLD36F | 79950 |
| 42 | 1050 | CBSBLD42F | 79951 |
| 48 | 1200 | CBSBLD48F | 79952 |
| 54 | 1350 | CBSBLD54F | 79953 |
| 60 | 1500 | CBSBLD60F | 79954 |
| 72 | 1800 | CBSBLD72F | 79955 |
| 84 | 2100 | CBSBLD84F | 79956 |
| 96 | 2400 | CBSBLD96F | 79957 |

Authorized Distributor:



2525 Wisconsin Avenue • Downers Grove, IL 60515-4200 • USA
Tel: (630) 971-0150 • Fax: (630) 971-1180 • E-mail: info@flexco.com

Visit www.flexco.com for other Flexco locations and products.

©2020 Flexible Steel Lacing Company. 05/18/20. For reorder: X4437

