

MHS with MST TENSIONER

Heavy-Duty Secondary Belt Cleaner

Superior Cleaning on the Toughest Belts

The MHS Heavy-Duty Secondary Belt Cleaner was designed to deliver and maintain superior cleaning efficiency, even on the most demanding, abusive beltlines. The MHS is the new answer to tough belt cleaning problems. It delivers high-efficiency cleaning, long-lasting performance—and with low maintenance.

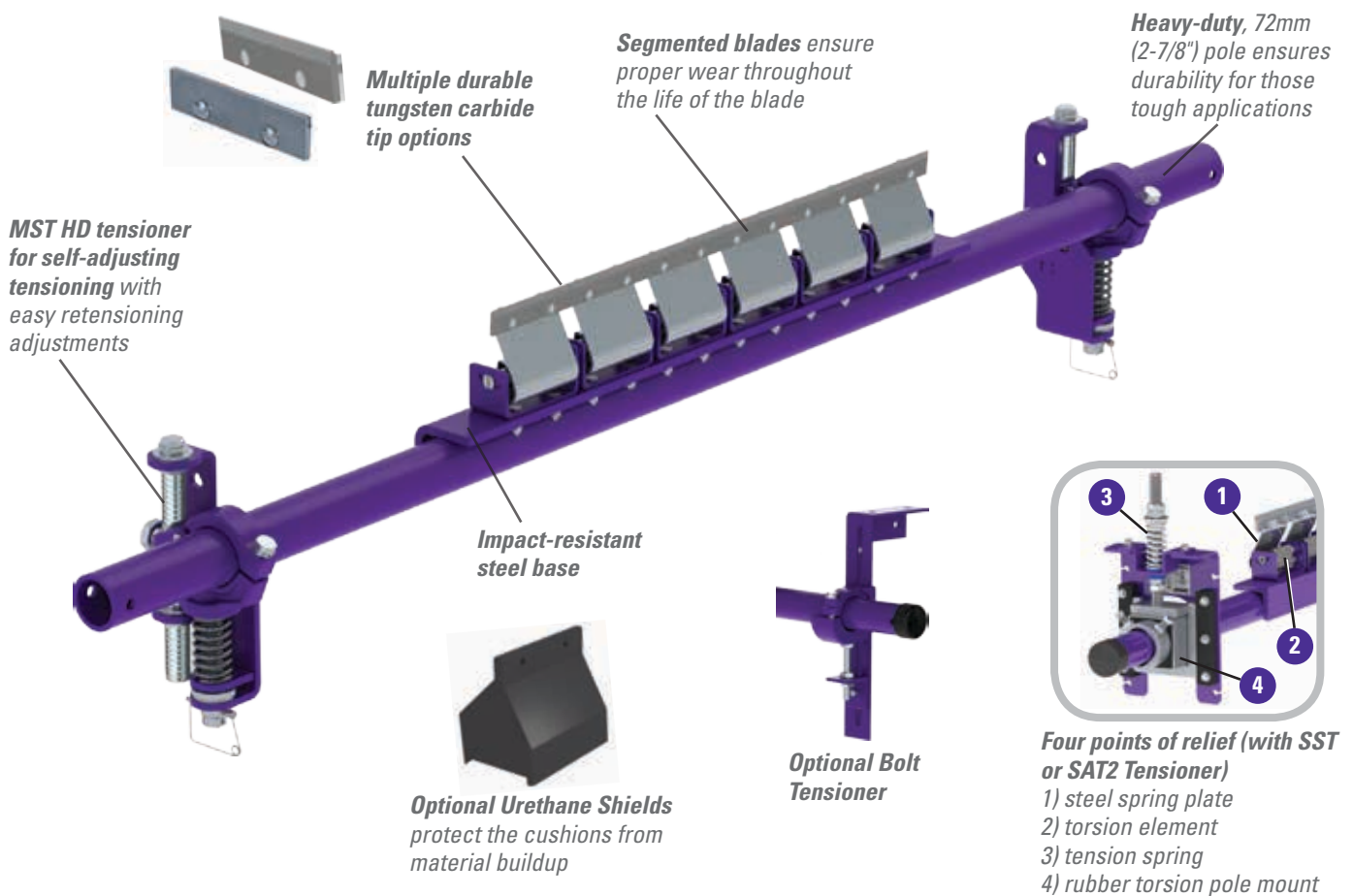

Features and Benefits

- **Cleaning efficiency of metal blades.** The thin, hard edges of the metal blades deliver high cleaning efficiency and long wear life.
- **Works with Flexco mechanical splices.** The C-Tip tungsten carbide blades are impact-resistant, and the spring cushion allows them to move away from a passing splice without damage and with minimal cleaning disruption. V-Tips can be used only on vulcanized belts.
- **A complete cleaning system.** When the MHS is teamed with the MMP primary cleaner the system provides maximum cleaning power for tough applications.
- **Made for mining conveyors.** Made from heavy-duty, corrosion-resistant steel, the MHS is available in sizes for belt widths from 450 to 2400mm. Additional sizes are available upon request.
- **Safe to service.** All service can be performed from a safe position at the side of the conveyor.
- **Also available in stainless steel.**

MHS with MST TENSIONER

Heavy-Duty Secondary Belt Cleaner

Specifications and Guidelines

Maximum Belt Speed

6 M/sec
5 M/sec with MST Tensioner

Temperature Rating

-35° C to 82° C

Usable Blade Wear Length

9mm

Blade Material

Impact resistant, long-lasting tungsten carbide (C-Tip for mechanical fasteners, V-Tips for vulcanized belts)

Available for Belt Widths

450 to 2400mm with SST or SAT2 Tensioner
450 to 1800mm with MST Tensioner

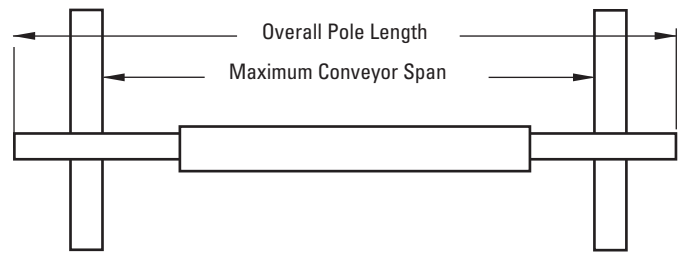

Pole Length Cleaner size + 1350mm
Maximum Conveyor Span Cleaner size + 1100mm

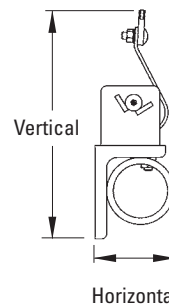

Horizontal Clearance Required
100mm

Vertical Clearance Required
245mm

Ordering Information

MHS HD with SST Tensioner*		
Belt Width mm	Ordering Number	Item Code
600	MHS-600FPV	77789
750	MHS-750FPV	77790
900	MHS-900FPV	77791
1050	MHS-1050FPV	77792
1200	MHS-1200FPV	77793
1350	MHS-1350FPV	77794
1500	MHS-1500FPV	77795
1800	MHS-1800FPV	77796
2100	MHS-2100FPV	77797
2400	MHS-2400FPV	77798

MHS HD with MST Tensioner*		
Belt Width mm	Ordering Number	Item Code
600	MHS-600-MST	64020
750	MHS-750-MST	64021
900	MHS-900-MST	64022
1050	MHS-1050-MST	64023
1200	MHS-1200-MST	64024
1350	MHS-1350-MST	64025
1500	MHS-1500-MST	64026
1800	MHS-1800-MST	64027
2100	MHS-2100-MST	64028
2400	MHS-2400-MST	64029

MHS HD with Bolt Tensioner*		
Belt Width mm	Ordering Number	Item Code
600	MHS-600BTV	77481
750	MHS-750BTV	77482
900	MHS-900BTV	77483
1050	MHS-1050BTV	77484
1200	MHS-1200BTV	77525
1350	MHS-1350BTV	77485
1500	MHS-1500BTV	77486
1800	MHS-1800BTV	77487
2100	MHS-2100BTV	77488
2400	MHS-2400BTV	77489

*Contact Flexco for Stainless Steel Options

Replacement Tips	
Ordering Number	Item Code
CT6	74535
RSA150	73628

Urethane Shields	
Ordering Number	Item Code
UPFCC	79320

Tips Required Per Cleaner Size											
mm	450	600	750	900	1050	1200	1350	1500	1800	2100	2400
in.	18	24	30	36	42	48	54	60	72	84	96
C-Tips or V-Tips Required	3	4	5	6	7	8	9	10	12	14	16

Authorized Distributor:

Flexco (Aust.) Pty. Ltd • 10 Solent Circuit • Baulkham Hills NSW 2153 • Australia
Tel: 612-8818-2000 • Fax: 612-8824-6333 • E-mail: salesau@flexco.com

Visit www.flexco.com for other Flexco locations and products.

©2016 Flexible Steel Lacing Company. 01/16. For reorder: X4107

