

MOTORIZED BRUSH CLEANER

Effective Cleaning Solution for Chevron, Cleated and Raised-rib Belts

Chevron, cleated and raised-rib belts present a special problem for efficient cleaning. The Motorized Brush Cleaner is an ideal option for cleaning these belts. It also performs well as the second or third cleaner in a system with worn or pitted belts, as the bristles effectively dislodge trapped material.

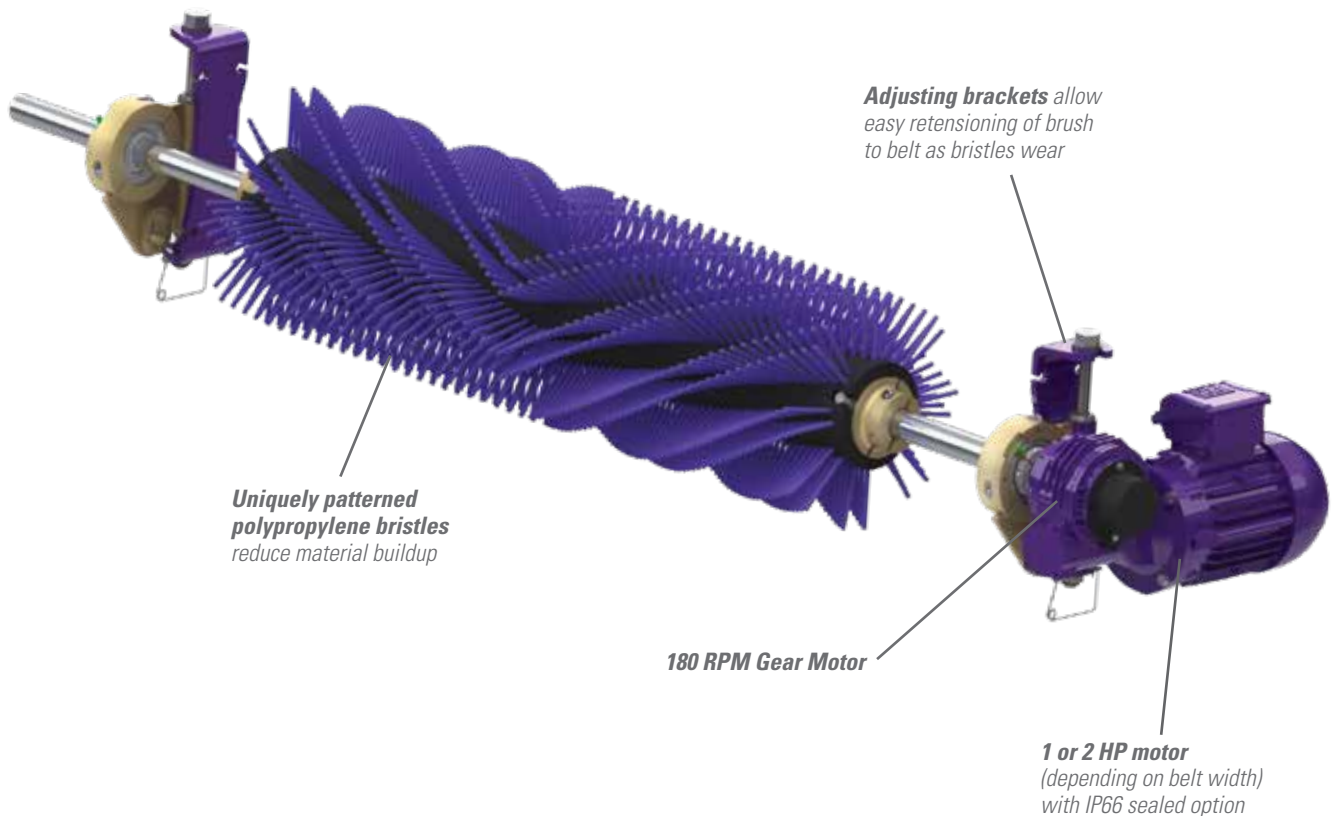

Features and Benefits

- **Maximum Cleaning.** Spins opposite the belt direction for optimal cleaning.
- **Uniquely patterned bristles.** Aids in reducing material buildup and clogging.
- **Adjustable tensioners.** Allows easy brush-to-belt adjustment as the bristles wear.
- **Works on mechanically spliced or vulcanized belts.**

MOTORIZED BRUSH CLEANER

Specifications and Guidelines

- Maximum Belt Speed**
 3.5 m/s (700 FPM)
- Temperature Rating**
 -30° C to 82° C (-20°F to 180° F)
- CEMA Cleaner Rating**
 Class 4
- Overall Brush Diameter**
 305mm (12")
- Bristle Material**
 Polypropylene
- Bristle Length**
 83mm (3-1/4")
- Brush RPM**
 180
- Shaft Diameter**
 38mm (1-1/2")
- Shaft Length**
 Belt Width +1067mm (42")
- Maximum Chevron or Cleat Height**
 13mm (1/2")
- Motor Voltage and HP**
208-230/460VAC 3 Phase*
 1HP Cleaners 450-1050mm (18-42")
 2HP Cleaners 1200-2100mm (48-84")
575V 3 Phase*
 1HP Cleaners 450-900mm (18-36")
 2HP Cleaners 1050-2100mm (42-84")
 *other motors available upon request
- Motor Ingress Protection**
 IP55 or IP66
- Available for Belt Widths**
 450 to 2100mm (18" to 84")
- Horizontal Clearance Required**
 305mm (12")
- Vertical Clearance Required**
 305mm (12")

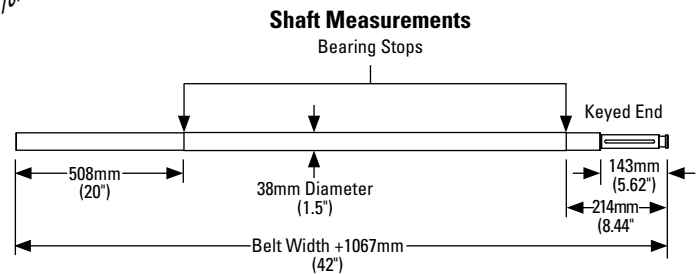
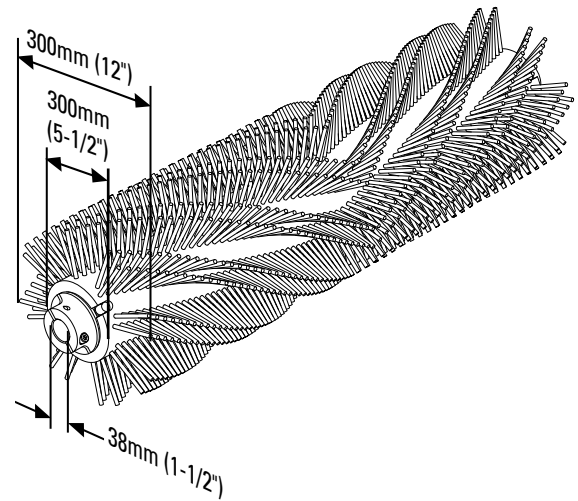
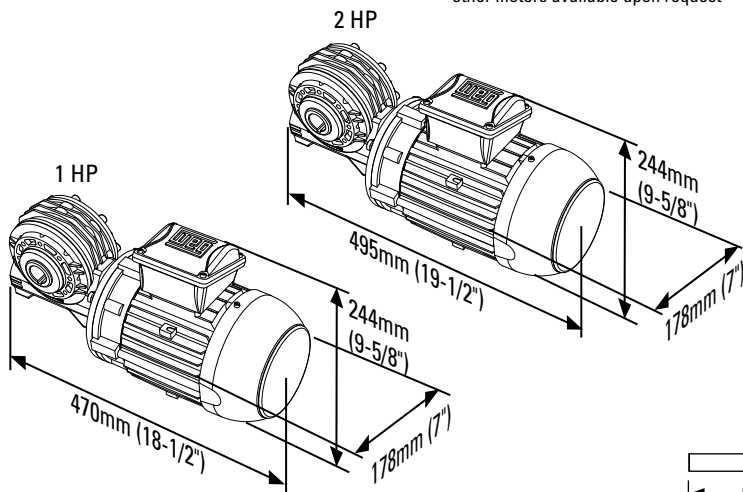

Ordering Information

Motorized Brush Cleaner 208-230/460 VAC 3-Phase Motor							
Belt Width		Brush Coverage		Ordering Number	Item Code		
mm	in.	mm	in.	IP55	IP66		
450	18	450	18	MBC-18	79494	MBC-18-S	91571
600	24	600	24	MBC-24	79495	MBC-24-S	91572
750	30	750	30	MBC-30	79496	MBC-30-S	91573
900	36	900	36	MBC-36	79497	MBC-36-S	91574
1050	42	1050	42	MBC-42	79498	MBC-42-S	91575
1200	48	1200	48	MBC-48	79499	MBC-48-S	91576
1350	54	1350	54	MBC-54	79500	MBC-54-S	91577
1500	60	1500	60	MBC-60	79501	MBC-60-S	91578
1800	72	1800	72	MBC-72	79502	MBC-72-S	91579
2100	84	2100	84	MBC-84	79503	MBC-84-S	91580

Motorized Brush Cleaner 575V 3-Phase Motor							
Belt Width		Brush Coverage		Ordering Number	Item Code		
mm	in.	mm	in.	IP55	IP66		
450	18	450	18	MBC-18-575V	79914	MBC-18-575V-S	91581
600	24	600	24	MBC-24-575V	79915	MBC-24-575V-S	91582
750	30	750	30	MBC-30-575V	79916	MBC-30-575V-S	91583
900	36	900	36	MBC-36-575V	79917	MBC-36-575V-S	91584
1050	42	1050	42	MBC-42-575V	79918	MBC-42-575V-S	91585
1200	48	1200	48	MBC-48-575V	79919	MBC-48-575V-S	91586
1350	54	1350	54	MBC-54-575V	79920	MBC-54-575V-S	91587
1500	60	1500	60	MBC-60-575V	79921	MBC-60-575V-S	91588
1800	72	1800	72	MBC-72-575V	79922	MBC-72-575V-S	91589
2100	84	2100	84	MBC-84-575V	79923	MBC-84-575V-S	91590

Replacement Brushes	
Ordering Number	Item Code
MBRD-18	79514
MBRD-24	79515
MBRD-30	79516
MBRD-36	79517
MBRD-42	79518
MBRD-48	79519
MBRD-54	79520
MBRD-60	79521
MBRD-72	79522
MBRD-84	79523

Authorized Distributor:

240 Macpherson Road • #02-01 • Singapore 348574
 Tel: +65-6484-1533 • Fax: +65-6484-1531 • E-mail: asiasales@flexco.com

Visit www.flexco.com for other Flexco locations and products.

©2020 Flexible Steel Lacing Company. 03/30/20. For reorder: X4012

