

Flexco Continuous Blade Secondary Belt Cleaner

Installation Instructions

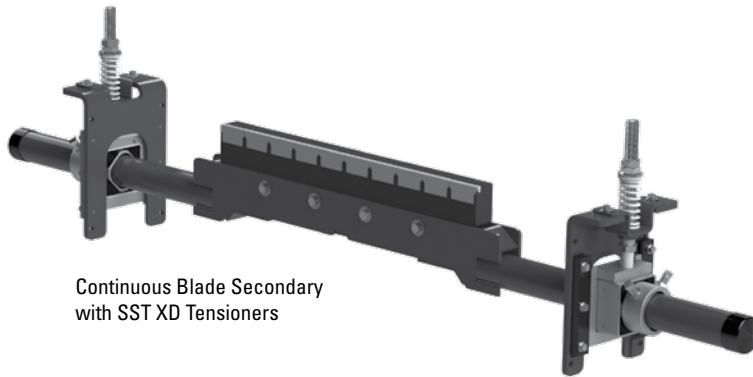

Continuous Blade Secondary
with SST XD Tensioners

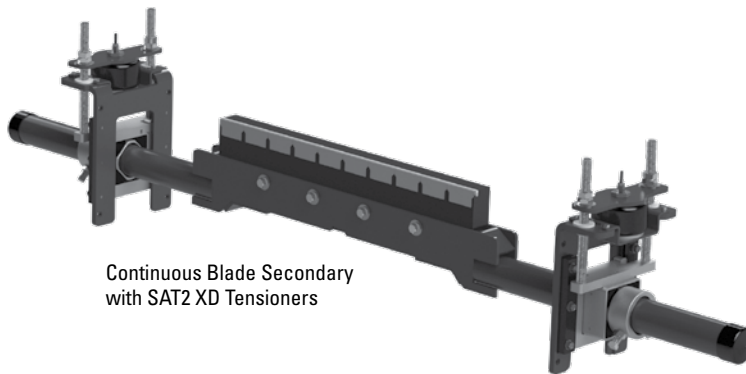

Continuous Blade Secondary
with SAT2 XD Tensioners

CBS Secondary Cleaner

Serial Number: _____
Purchase Date: _____
Purchased From: _____
Installation Date: _____

Serial number information can be found on the Serial Number Label included in the Information Packet found in the cleaner carton.

This information will be helpful for any future inquiries or questions about belt cleaner replacement parts, specifications or troubleshooting.

Table of Contents

Section 1 - Important Information	4
1.1 General Introduction.....	4
1.2 User Benefits	4
1.3 Service Option.....	4
Section 2 - Safety Considerations and Precautions	5
2.1 Stationary Conveyors.....	5
2.2 Operating Conveyors.....	5
Section 3 - Pre-Installation Checks and Options.....	6
3.1 Checklist.....	6
3.2 Optional Installation Accessories.....	7
Section 4 - Installation Instructions.....	8
4.1 Installation Instructions - CBS with SST XD or SAT XD Tensioner.....	8
4.2 Push-up Tensioning Instructions (SST XD).....	10
4.3 Push-up Tensioning Instructions (SAT XD)	11
Section 5 - Pre-Operation Checklist and Testing.....	12
5.1 Pre-Op Checklist.....	12
5.2 Test Run the Conveyor	12
Section 6 - Maintenance.....	13
6.1 New Installation Inspection.....	13
6.2 Routine Visual Inspection.....	13
6.3 Routine Physical Inspection	13
6.4 Maintenance Log.....	14
6.5 Cleaner Maintenance Checklist.....	15
Section 7 - Troubleshooting	16
Section 8 - Specs and CAD Drawings.....	17
8.1 Specs and Guidelines	17
8.2 CAD Drawing - CBS Cleaners with SST XD Tensioners.....	18
8.3 CAD Drawing - CBS Cleaners with SAT XD Tensioners	19
Section 9 - Replacement Parts.....	20
9.1 Replacement Parts List	20
Section 10 - Other Flexco Conveyor Products.....	21

Section 1 - Important Information

1.1 General Introduction

We at Flexco are very pleased that you have selected a CBS Secondary Cleaner for your conveyor system.

This manual will help you to understand the operation of this product and assist you in making it work up to its maximum efficiency over its lifetime of service.

It is essential for safe and efficient operation that the information and guidelines presented be properly understood and implemented. This manual will provide safety precautions, installation instructions, maintenance procedures and troubleshooting tips.

If, however, you have any questions or problems that are not covered, please contact your field representative or our Customer Service Department:

Customer Service: USA: 1-800-541-8028

Visit www.flexco.com for other Flexco locations and products.

Please read this manual thoroughly and pass it on to any others who will be directly responsible for installation, operation and maintenance of this cleaner. While we have tried to make the installation and service tasks as easy and simple as possible, **it does however require correct installation and regular inspections and adjustments to maintain top working condition.**

1.2 User Benefits

Correct installation and regular maintenance will provide the following benefits for your operation:

- Reduced conveyor downtime
- Reduced man-hour labor
- Lower maintenance budget costs
- Increased service life for the belt cleaner and other conveyor components

1.3 Service Option

The CBS Secondary Cleaner is designed to be easily installed and serviced by your on-site personnel. However, if you would prefer complete turn-key factory service, please contact your local Flexco Field Representative.

Section 2 - Safety Considerations and Precautions

Before installing and operating the CBS Secondary Cleaner, it is important to review and understand the following safety information.

There are set-up, maintenance and operational activities involving both **stationary** and **operating** conveyors. Each case has a safety protocol.

2.1 Stationary Conveyors

The following activities are performed on stationary conveyors:

- Installation
- Blade replacement
- Repairs
- Tension adjustments
- Cleaning

DANGER

It is imperative that OSHA/MSHA Lockout/Tagout (LOTO) regulations, 29 CFR 1910.147, be followed before undertaking the preceding activities. Failure to use LOTO exposes workers to uncontrolled behavior of the belt cleaner caused by movement of the conveyor belt. Severe injury or death can result.

Before working:

- Lockout/Tagout the conveyor power source
- Disengage any takeups
- Clear the conveyor belt or clamp securely in place

WARNING

Use Personal Protective Equipment (PPE):

- Safety eyewear
- Hardhats
- Safety footwear

Close quarters, springs and heavy components create a worksite that compromises a worker's eyes, feet and skull.

PPE must be worn to control the foreseeable hazards associated with conveyor belt cleaners. Serious injuries can be avoided.

2.2 Operating Conveyors

There are two routine tasks that must be performed while the conveyor is running:

- Inspection of the cleaning performance
- Dynamic troubleshooting

DANGER

Every belt cleaner is an in-running nip hazard. Never touch or prod an operating cleaner. Cleaner hazards cause instantaneous amputation and entrapment.

WARNING

Belt cleaners can become projectile hazards. Stay as far from the cleaner as practical and use safety eyewear and headgear. Missiles can inflict serious injury.

WARNING

Never adjust anything on an operating cleaner. Unforseeable belt projections and tears can catch on cleaners and cause violent movements of the cleaner structure. Flailing hardware can cause serious injury or death.

Section 3 - Pre-installation Checks and Options

3.1 Checklist

- Check that the cleaner size is correct for the beltline width
- Check the belt cleaner carton and make sure all the parts are included
- Review the “Tools Needed” list on the top of the installation instructions
- Check the conveyor site:
 - Will the cleaner be installed on a chute
 - Is the install on an open head pulley requiring mounting structure (see 3.2 - Optional Installation Accessories)

Section 3 - Pre-installation Checks and Options

3.2 Optional Installation Accessories

Versatile, adjustable brackets that can be mounted on the conveyor structure so the MHS HD Secondary Cleaner can be quickly and easily bolted into place. Pole extenders are also available for wide, non-standard conveyor structures.

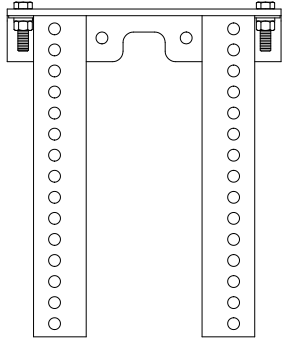

76071
SST Standard
Mounting Bracket Kit
(for SST Tensioner)

- For most secondary cleaner installs.
- 13" (325mm) W x 15 1/2" (388mm) L

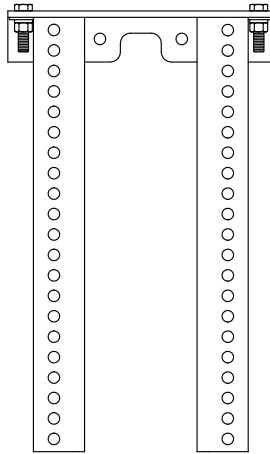

76072
SST Long
Mounting Bracket Kit
(for SST Tensioner)

- For installations that require extra length legs.
- 13" (325mm) W x 21 1/2" (538mm) L

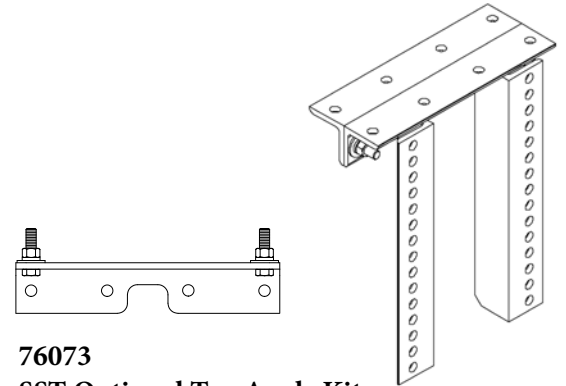

76073
SST Optional Top Angle Kit
(for SST Tensioner)

- Used with both standard and long mounting bracket kits for additional mounting options.
- 13" (325mm) L

76024
Pole Extender Kit (includes 2 pole extenders)
 • For cleaner sizes 72" (1800mm) and larger
 • Provides 30" (750mm) of extended pole length

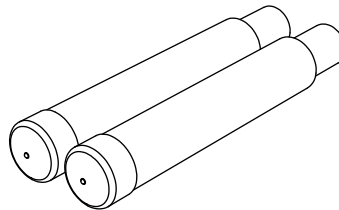

Optional Mounting Kits (includes 2 brackets/bars)			
Description	Ordering Number	Item Code	Wt. Lbs.
Standard Mounting Bracket Kit *	SSTSMB	76071	34.3
Long Mounting Bracket Kit *	SSTLMB	76072	43.5
Optional Top Angle Kit *	SSTOTA	76073	10.5
Pole Extender Kit	MAPEK	76024	21.9

*Hardware Included
 Lead time: 1 working day

Section 4 - Installation Instructions

4.1 Continuous Blade Secondary Cleaner

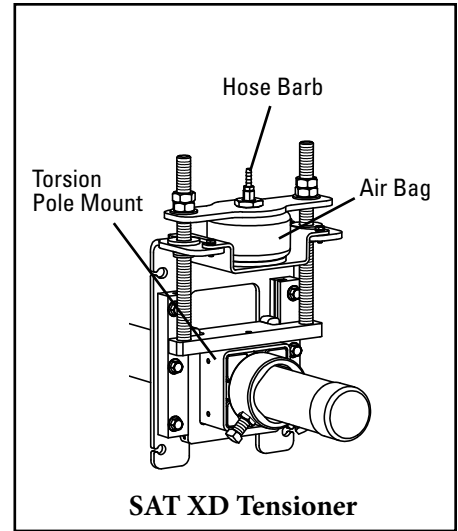
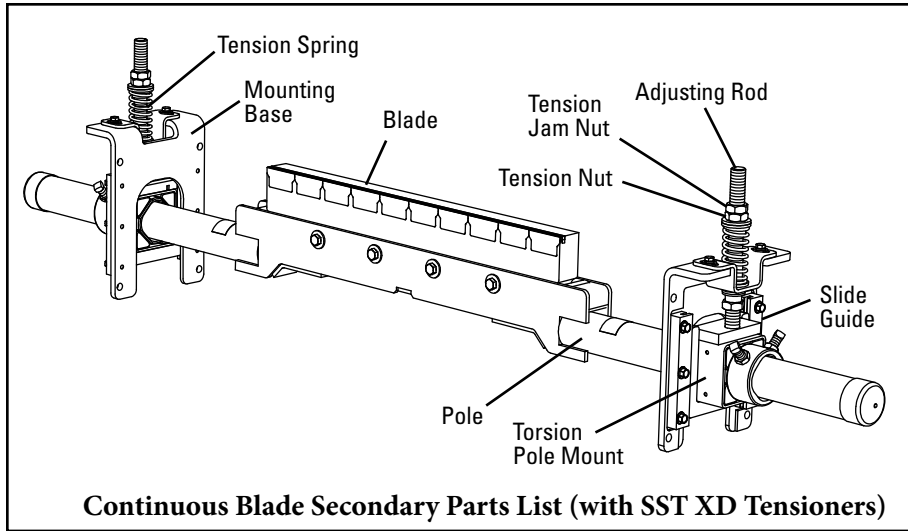

Physically lock out and tag the conveyor at the power source before you begin cleaner installation.

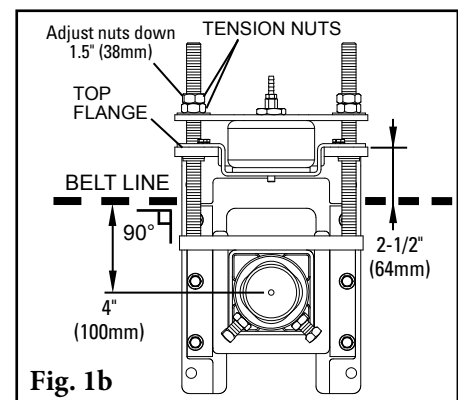
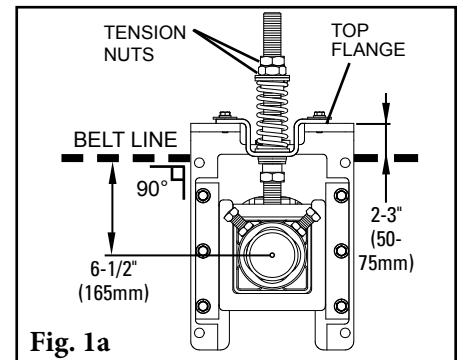
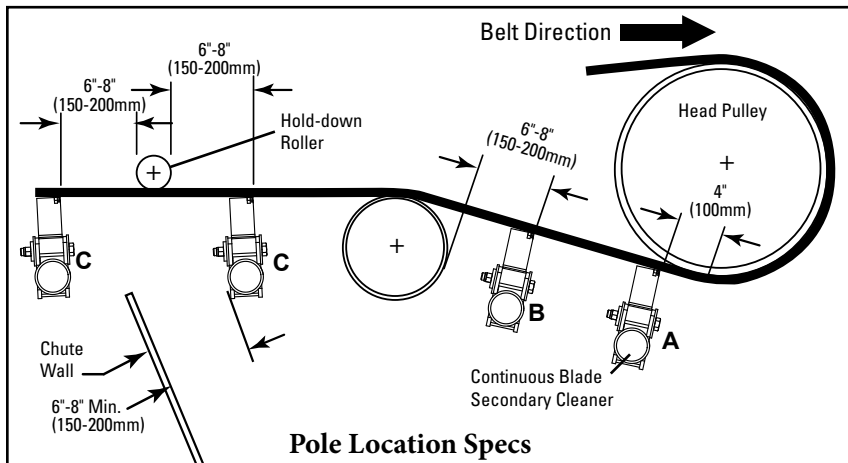

1. Install the mounting bases.

1a. Spring tensioner mounting bases: (For push-up tensioning refer to additional instructions on Page 10.) Clamp one mounting base into position so the top flange of the base is 2-3" (50-75mm) above the belt. Bolt or weld the mounting base in place. Locate and install the mounting base on the opposite side. Adjust the tension nuts on each side so the center of the torsion pole mount is 6-1/2" (165mm) below the belt line (Fig. 1a).

1b. Air/water tensioner mounting bases: Clamp one mounting base into position so the top flange of the base is 2-1/2" (64mm) above the belt. Bolt or weld the mounting base in place and adjust threaded rod nuts 1-1/2" (38mm) down from top of threaded rods (Fig. 1b). Repeat on opposite side.

NOTE: For chute mounting, a belt location line must be drawn on the chute wall so the mounting base can be aligned with the belt. Cut access holes as needed (Fig. 1c).

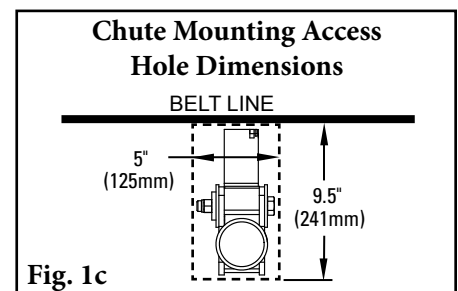

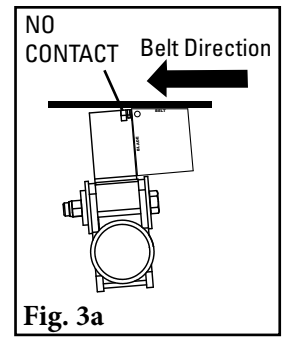
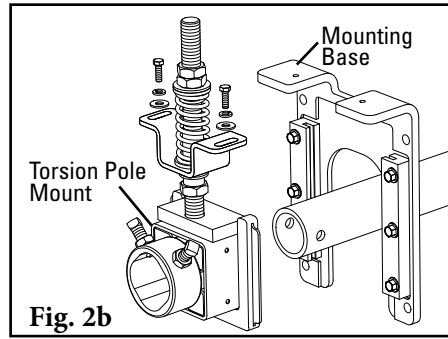
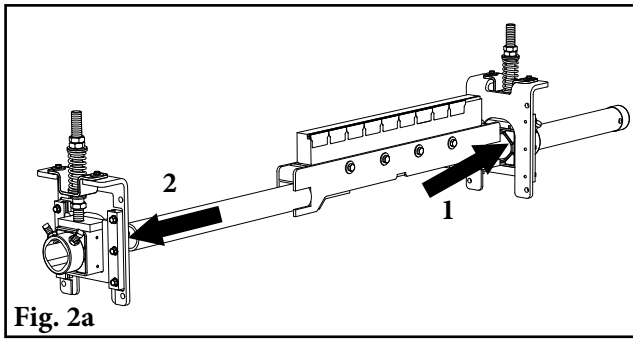

2. **Install the pole.** Slide the pole into one torsion pole mount as far as needed and locate the other end into the opposite mount (Fig. 2a). If there is not enough space, remove one of the torsion pole mounts from the mounting base, slide the pole through the mounting base and reassemble (Fig. 2b).

3. **Set the blade angle.** Center the pole/blades on the belt. Rotate the pole until the blade lays back 5° using the setup gauge provided (Fig. 3a). Tighten the two locking bolts on each torsion pole mount to lock the pole in place (Fig. 3b). There should be no blade-to-belt contact while locking the pole in the correct position. If contact occurs, double-check the dimension from Step 1. **NOTE:** For optimal cleaning performance, it is recommended that mechanical fasteners on the belt be skived.

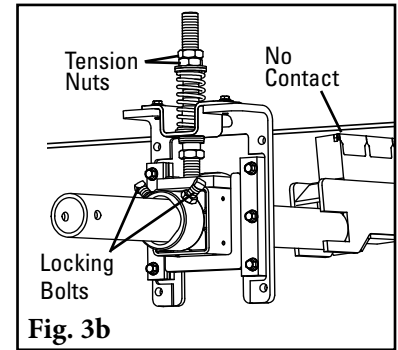

4. **Set the blade tension.**

4a. **Spring Tensioner:** Loosen the top tension jam nuts on both sides. Turn the tension nuts until the correct spring compression is reached (Fig. 4a). Spring compression is determined by spring length. See the chart at right for the correct spring length for your belt width.

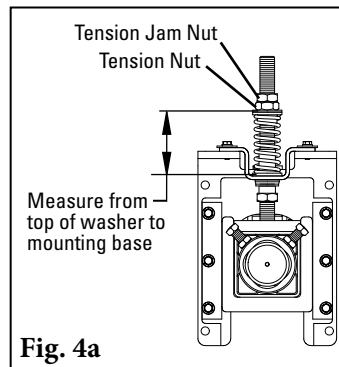

Fig. 4a Measure from the top of flat washer to the mounting base to determine spring length.

SST XD Tensioner Spring Length Chart

Blade Width		White Spring		Silver Spring		Black Spring		Gold Spring	
in.	mm	in.	mm	in.	mm	in.	mm	in.	mm
18	450	3 3/8	86	4	102	N/A	N/A	N/A	N/A
24	600	3 1/8	79	3 7/8	98	N/A	N/A	N/A	N/A
30	750	2 7/8	73	3 3/4	95	N/A	N/A	N/A	N/A
36	900	N/A	N/A	3 3/4	95	3 7/8	98	N/A	N/A
42	1050	N/A	N/A	3 5/8	92	3 3/4	95	N/A	N/A
48	1200	N/A	N/A	3 1/2	89	3 5/8	92	N/A	N/A
54	1350	N/A	N/A	3 3/8	86	3 5/8	92	3 3/4	95
60	1500	N/A	N/A	3 1/4	83	3 1/2	89	3 3/4	95
72	1800	N/A	N/A	N/A	N/A	N/A	3 3/8	86	3 5/8
84	2100	N/A	N/A	N/A	N/A	3 1/8	79	3 1/2	89
96	2400	N/A	N/A	N/A	N/A	N/A	N/A	3 3/8	86

Shading indicates preferred spring option.

4b. **Air Tensioner:** With the parts supplied, attach a line to each air bag and run the lines to the outlet side of the control box (Fig. 4b). **NOTE:** Be sure lines are safely away from the belt. Connect the line from the inlet side of the box to the site's supply or air tank. Test the connections for leaks and set the pressure per the chart at right. Pressure may be reduced to suit application. See the chart at right for the correct air pressure for your belt width.

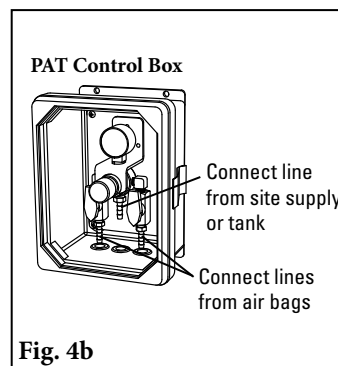

Fig. 4b

SAT XD Tensioner Pressure Chart

Blade Width		Blades	Pressure	
in.	mm		psi	kPa
18	450	3	15#	103
24	600	4	19#	131
30	750	5	23#	159
36	900	6	27#	186
42	1050	7	31#	214
48	1200	8	35#	241
54	1350	9	39#	269
60	1500	10	43#	296
72	1800	12	51#	352
84	2100	14	59#	407
96	2400	16	67#	462

5. **Set adjusting rod sleeve (Spring Tensioner only).** After setting the blade tension, screw the adjusting rod sleeve into the UHMW bushing until 1-1/2" (38mm) is showing (Fig. 5). Tighten the adjusting rod sleeve jam nut.

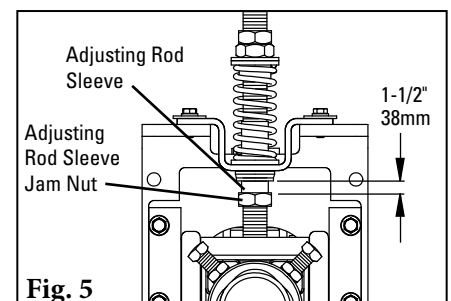

Fig. 5

6. **Test run the cleaner and inspect the cleaning performance.** If vibration occurs or more cleaning efficiency is desired, increase the blade tension by making 1/8" (3mm) compression adjustments on the tension springs. If vibration occurs on cleaner with air tensioner, increase blade layback.

Push-up Tensioning Instructions

CBS with SST XD Tensioners

To change the SST XD Tensioner to Push-up configuration, follow these steps:

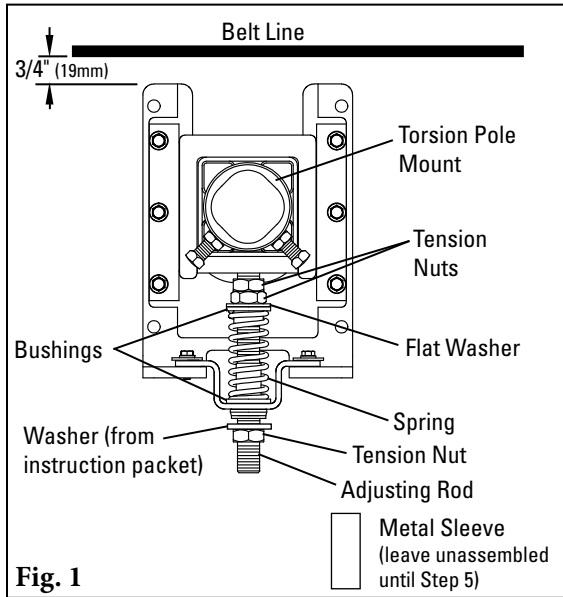

1. **Reconfigure the standard pull-up tensioner to the push-up style.** Remove the 3 tension nuts, flat washer, 2 bushings, spring, sleeve and hat bracket; reassemble (Fig. 1) with 2 tension nuts, flat washer, 2 bushings, spring and hat bracket on upper end of adjusting rod. Add washer (from instruction packet) and third tension nut to bottom of adjusting rod.
2. **Install the tensioner mounting bases.** Mount the bases to the structure or chute so that the tops of the base legs are 3/4" (19mm) below the belt (Fig. 1).
3. **Install the cleaner pole and set the blade angle.** Follow the installation steps from the cleaner instructions on Page 2. **Note:** be sure the lock bolts on the torsion pole mount have been securely tightened to lock the pole in place before moving to Step 4.
4. **Set the blade tension.** Remove the bottom tension nut and washer from the adjusting rod. Turn the two upper tension nuts until the spring is compressed to the length shown on the Spring Length Chart below. Tighten the two tension nuts together to prevent loosening.

SST XD Tensioner Spring Length Chart

Blade Width		White Spring		Silver Spring		Black Spring		Gold Spring	
in.	mm	in.	mm	in.	mm	in.	mm	in.	mm
18	450	3 3/8	86	4	102	N/A	N/A	N/A	N/A
24	600	3 1/8	79	3 7/8	98	N/A	N/A	N/A	N/A
30	750	2 7/8	73	3 3/4	95	N/A	N/A	N/A	N/A
36	900	N/A	N/A	3 3/4	95	3 7/8	98	N/A	N/A
42	1050	N/A	N/A	3 5/8	92	3 3/4	95	N/A	N/A
48	1200	N/A	N/A	3 1/2	89	3 5/8	92	N/A	N/A
54	1350	N/A	N/A	3 3/8	86	3 5/8	92	3 3/4	95
60	1500	N/A	N/A	3 1/4	83	3 1/2	89	3 3/4	95
72	1800	N/A	N/A	N/A	N/A	3 3/8	86	3 5/8	92
84	2100	N/A	N/A	N/A	N/A	3 1/8	79	3 1/2	89
96	2400	N/A	N/A	N/A	N/A	N/A	N/A	3 3/8	86

Shading indicates preferred spring option.

NOTE: Measure from the top of the flat washer to the mounting base to determine spring length.

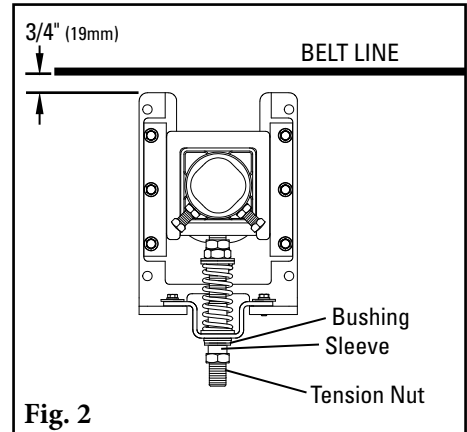
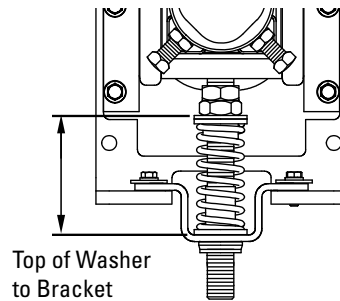

5. **Replace the sleeve.** Position the sleeve over the adjusting rod and turn it until it is in the middle of the bushing. Replace the bottom tension nut and tighten until it locks the sleeve in place (Fig. 2).

Push-up Tensioning Instructions

CBS with SAT XD Tensioners

To change the SAT XD Tensioner to Push-up configuration, follow these steps:

1. **Disassemble guide kit.** Remove nuts and washers from both sides of tensioner (Fig. 1).
2. **Disassemble upper mounting plate and air bag.** Remove and save bushing nut. Remove and discard upper mounting plate. Remove (unscrew) and save air bag, threaded insert and support plate (Fig. 2). **Optional:** Remove guide bushings. It will not affect the tensioner if these are left in place.
3. **Remove and save top hat bracket and its hardware** (Fig. 3).
4. **Flip over PAT mounting bracket assembly.** The two flanges are now at the bottom.

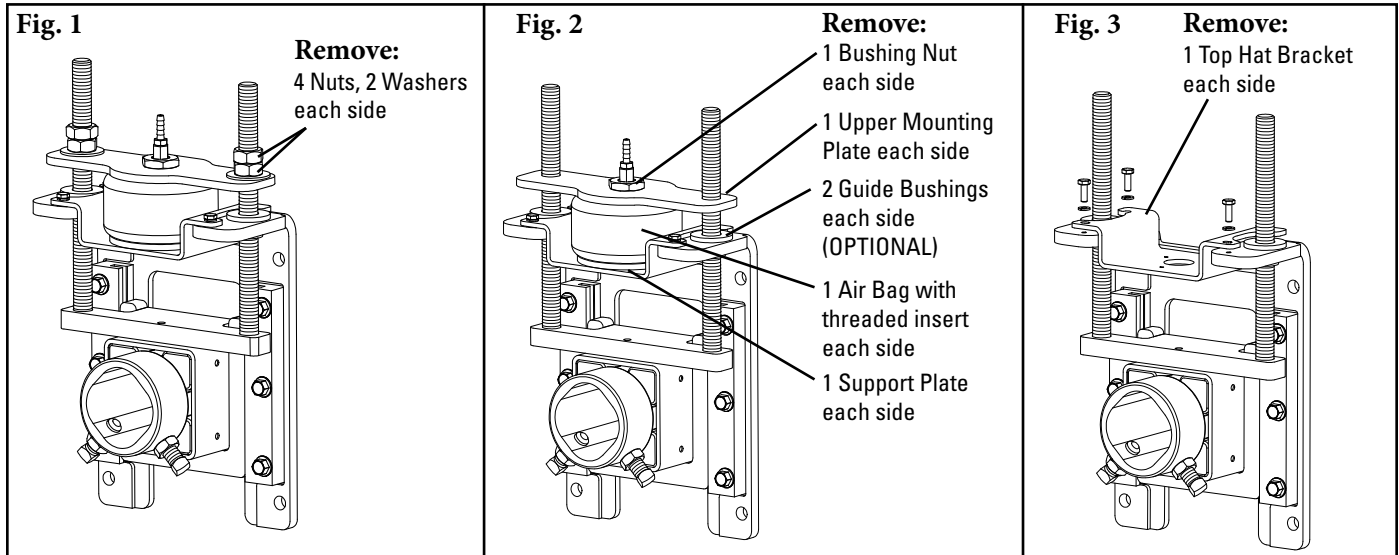

5. **Reassemble the SAT XD Tensioner.** Remove three screws from air bag support plate (Fig. 4a). Turn the threaded insert into the support plate. Also turn part of the threaded insert into the hole on pole mount. (Fig. 4b). Ensure 1/4" (6mm) of threaded insert is still exposed, then turn the air bag onto the threaded insert and tighten (Fig. 5).
6. **Reassemble top hat bracket.** Ensure bracket is resting on flanges of mounting bracket (Fig. 6).
7. **Slide pole mount/threaded rods/air bag assembly down** with hose barb through hole in top hat bracket and reinstall bushing nut (Fig. 6).
8. **Complete installation** by following the steps on page 9.

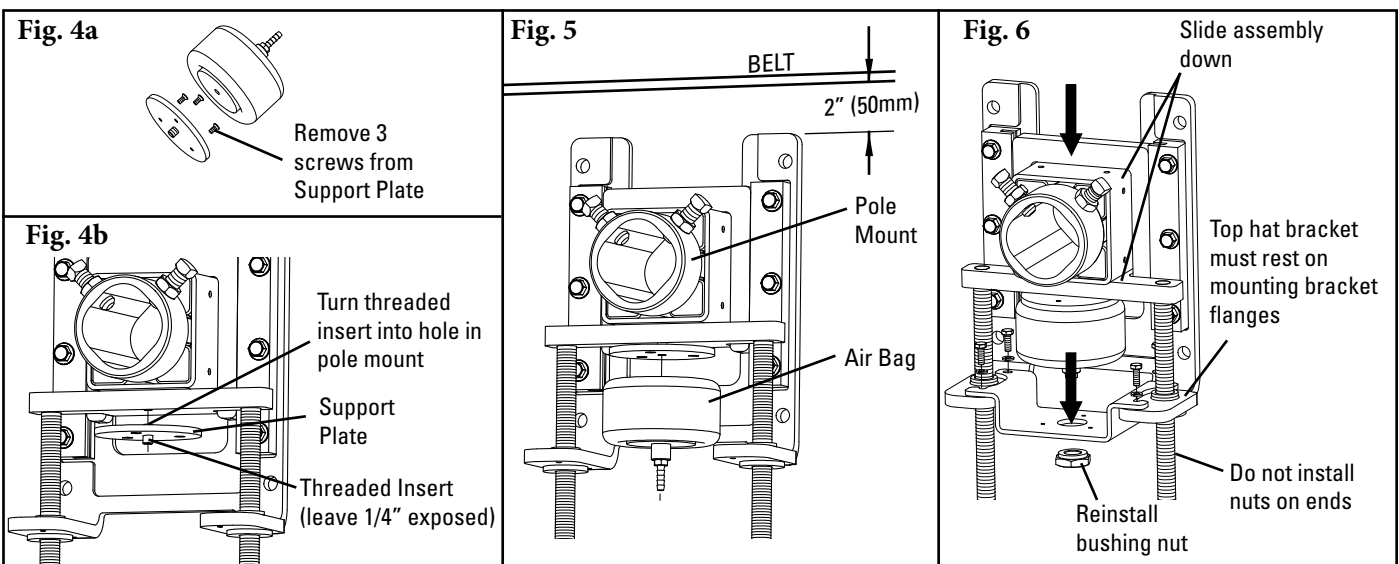

Section 5 - Pre-Operation Checklist and Testing

5.1 Pre-Op Checklist

- Recheck that all fasteners are tightened properly
- Add pole caps
- Apply all supplied labels to the cleaner
- Check the blade location on the belt
- Be sure that all installation materials and tools have been removed from the belt and the conveyor area

5.2 Test Run the Conveyor

- Run the conveyor for at least 15 minutes and inspect the cleaning performance
- Check the tensioner spring for recommended length (proper tensioning)
- Make adjustments as necessary

NOTE: Observing the cleaner when it is running and performing properly will help to detect problems or when adjustments are needed later.

Section 6 - Maintenance

Flexco belt cleaners are designed to operate with minimum maintenance. However, to maintain superior performance some service is required. When the cleaner is installed a regular maintenance program should be set up. This program will ensure that the cleaner operates at optimal efficiency and problems can be identified and fixed before the cleaner stops working.

All safety procedures for inspection of equipment (stationary or operating) must be observed. The CBS Belt Cleaner operates at the discharge end of the conveyor and is in direct contact with the moving belt. Only visual observations can be made while the belt is running. Service tasks can be done only with the conveyor stopped and by observing the correct lockout/tagout procedures.

6.1 New Installation Inspection

After the new cleaner has run for a few days a visual inspection should be made to ensure the cleaner is performing properly. Make adjustments as needed.

6.2 Routine Visual Inspection (every 2-4 weeks)

A visual inspection of the cleaner and belt should look for:

- If spring length is the correct length for optimal tensioning
- If belt looks clean or if there are areas that are dirty
- If blade is worn out and needs to be replaced
- If there is damage to the blade or other cleaner components
- If fugitive material is built up on cleaner or in the transfer area
- If there is cover damage to the belt
- If there is vibration or bouncing of the cleaner on the belt
- If a snub pulley is used, a check should be made for material buildup on the pulley
- Significant signs of carryback

If any of the above conditions exist, a determination should be made on when the conveyor can be stopped for cleaner maintenance.

6.3 Routine Physical Inspection (every 6-8 weeks)

When the conveyor is not in operation and properly locked and tagged out, a physical inspection of the cleaner to perform the following tasks:

- Clean material buildup off of the cleaner blade and pole
- Closely inspect the blade for wear and any damage. Replace if needed.
- Ensure full blade to belt contact
- Inspect the cleaner pole for damage
- Inspect all fasteners for tightness and wear. Tighten or replace as needed.
- Replace any worn or damaged components
- Check the tension of the cleaner blade to the belt. Adjust the tension if necessary using the chart on the cleaner or the ones on Page 9 (SST spring tensioner or SAT2 air tensioner).
- When maintenance tasks are completed, test run the conveyor to ensure the cleaner is performing properly

Section 6 - Maintenance

6.4 Maintenance Log

Conveyor Name/No. _____

Date: _____ Work done by: _____ Service Quote # _____

Activity: _____

Date: _____ Work done by: _____ Service Quote # _____

Activity: _____

Date: _____ Work done by: _____ Service Quote # _____

Activity: _____

Date: _____ Work done by: _____ Service Quote # _____

Activity: _____

Date: _____ Work done by: _____ Service Quote # _____

Activity: _____

Date: _____ Work done by: _____ Service Quote # _____

Activity: _____

Date: _____ Work done by: _____ Service Quote # _____

Activity: _____

Section 6 - Maintenance

6.5 Cleaner Maintenance Checklist

Belt Cleaner: _____ Serial Number: _____

Beltline Information:

Beltline Number: _____ Belt Condition: _____

Belt Width: 18" 24" 30" 36" 42" 48" 54" 60" 72" 84" 96"
(450mm) (600mm) (750mm) (900mm) (1050mm) (1200mm) (1350mm) (1500mm) (1800mm) (2100mm) (2400mm)

Belt Speed: _____ fpm Belt Thickness: _____

Belt Splice _____ Condition of Splice _____ Number of splices _____ Skived* Unskived
* It is recommended that mechanical fasteners on the belt be skived.

Material conveyed _____

Days per week run _____ Hours per day run _____

Blade Life:

Date blades installed: _____ Date blades inspected: _____ Estimated blade life: _____

Are blades making complete contact with belt? Yes No

Blade wear: LEFT _____ MIDDLE _____ RIGHT _____

Blade condition: Good Grooved Smiled Not contacting belt Damaged

Measurement of spring: Required _____ Currently _____

For SAT XD Tensioner only: Air/Nitrogen Pressure Required _____ Currently _____
Inspect SAT XD bags and lines

Yes No

Was Cleaner Adjusted:

Good Bent Worn

Pole Condition:

Lagging: Slide lag Ceramic Rubber Other None

Condition of lagging: Good Bad Other _____

Cleaner's Overall Performance: (Rate the following 1 - 5, 1 = very poor - 5 = very good)

Appearance: Comments: _____

Location: Comments: _____

Maintenance: Comments: _____

Performance: Comments: _____

Other Comments: _____



Section 7 - Troubleshooting

7.1 Troubleshooting Guide

Problem	Possible Cause	Possible Solutions
Vibration	Cleaner secure bolts not set	Ensure all locking nuts are tight (Loctite)
	Cleaner not set up correctly	Ensure cleaner set up properly (check tip angle with gauge)
	Belt tension too high	Ensure cleaner can conform to belt, or replace with alternate Flexco secondary cleaner
	Belt flap	Introduce hold-down roller to flatten belt
	Cleaner over-tensioned	Ensure cleaner is correctly tensioned
	Cleaner under-tensioned	Ensure cleaner is correctly tensioned
	Nylon bearing worn out or missing	Replace nylon bearing
Material buildup on cleaner	Cleaner not set up correctly	Ensure cleaner set up properly (5° laid back)
	Buildup on chute	Ensure cleaner is not located too close to back of chute, allowing buildup
	Cleaner being overburdened	Introduce Flexco precleaner
	Excessive sticky material	Frequently clean unit of buildup
Damaged belt cover	Cleaner over-tensioned	Ensure cleaner is correctly tensioned
	Cleaner blade damage	Check blade for wear, damage and chips, replace where necessary
	Attack angle not correct	Ensure cleaner set up properly (check tip angle with gauge)
	Material buildup in chute	Frequently clean unit of buildup
Cleaner not conforming to belt	Cleaner not set up correctly	Ensure cleaner set up properly (check tip angle with gauge)
	Belt tension too high	Ensure cleaner can conform to belt (introduce hold-down roller), or replace with alternate Flexco secondary cleaner
	Belt flap	Introduce hold-down roller to flatten belt
	Cleaner cannot conform	Ensure cleaner can conform to belt (introduce hold-down roller), or replace with alternate Flexco secondary cleaner
Material passing cleaner	Cleaner not set up correctly	Ensure cleaner set up properly (check tip angle with gauge)
	Cleaner tension too low	Ensure cleaner is correctly tensioned
	Cleaner blade worn/damaged	Check blade for wear, damage and chips, replace where necessary
	Cleaner being overburdened	Introduce Flexco precleaner
	Belt flap	Introduce hold-down roller to flatten belt
	Belt worn or grooved	Introduce water spray pole
	Cleaner cannot conform	Ensure cleaner can conform to belt (introduce hold-down roller), or replace with alternate Flexco secondary cleaner
	Blade in backwards	Install blade correctly and set correct tension
Damage to mechanical fastener	Incorrect cleaner blade selection	Change blade type to accomodate fastener style (UC or UF)
	Belt not skived correctly	Spot and redo splice correctly, lowering the profile flush or below belt surface
	Blade angle incorrect	Reset with gauge
Missing material in belt center only	Cupped Belt	Install hold-down roller and reset blade angle with gauge
	Cleaner blade worn/damaged	Check blade for wear, damage and chips, replace where necessary
Missing material on outer edges only	Cupped Belt	Install hold-down roller and reset blade angle with gauge
	Cleaner blade worn/damaged	Check blade for wear, damage and chips, replace where necessary

Section 8 - Specs and CAD Drawings

8.1 Specs and Guidelines

Pole Length Specifications*

CLEANER SIZE		BLADE WIDTH		POLE LENGTH		MAXIMUM CONVEYOR SPAN	
in.	mm	in.	mm	in.	mm	in.	mm
18	450	18	450	72	1800	62	1550
24	600	24	600	78	1950	68	1700
30	750	30	750	84	2100	74	1850
36	900	36	900	90	2250	80	2000
42	1050	42	1050	96	2400	86	2150
48	1200	48	1200	102	2550	92	2300
54	1350	54	1350	108	2700	98	2450
60	1500	60	1500	114	2850	104	2600
72	1800	72	1800	126	3150	116	2900
84	2100	84	2100	138	3450	128	3200
96	2400	96	2400	150	3750	140	3500

*For special extra long pole length requirements a Pole Extender Kit (#76024) is available that provides 30" (760mm) of extended pole length. See Page 7. Pole Diameter - 2-7/8" (73mm)

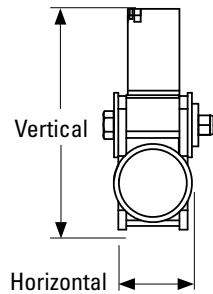
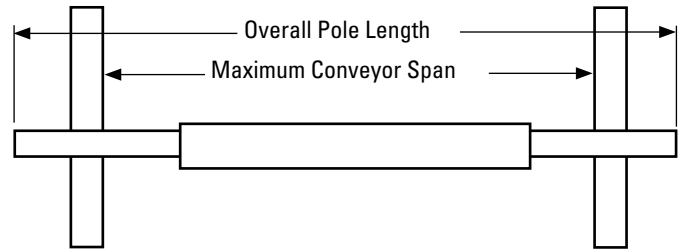

Clearance Guidelines for Installation

HORIZONTAL CLEARANCE REQUIRED		VERTICAL CLEARANCE REQUIRED	
in.	mm	in.	mm
4-1/2	115	9	229

SST XD Tensioner Spring Length Chart

Blade Width		White Spring		Silver Spring		Black Spring		Gold Spring	
in.	mm	in.	mm	in.	mm	in.	mm	in.	mm
18	450	3 3/8	86	4	102	N/A	N/A	N/A	N/A
24	600	3 1/8	79	3 7/8	98	N/A	N/A	N/A	N/A
30	750	2 7/8	73	3 3/4	95	N/A	N/A	N/A	N/A
36	900	N/A	N/A	3 3/4	95	3 7/8	98	N/A	N/A
42	1050	N/A	N/A	3 5/8	92	3 3/4	95	N/A	N/A
48	1200	N/A	N/A	3 1/2	89	3 5/8	92	N/A	N/A
54	1350	N/A	N/A	3 3/8	86	3 5/8	92	3 3/4	95
60	1500	N/A	N/A	3 1/4	83	3 1/2	89	3 3/4	95
72	1800	N/A	N/A	N/A	N/A	3 3/8	86	3 5/8	92
84	2100	N/A	N/A	N/A	N/A	3 1/8	79	3 1/2	89
96	2400	N/A	N/A	N/A	N/A	N/A	N/A	3 3/8	86

Shading indicates preferred spring option. Measure spring as shown below.

Top of Washer to Mounting Base

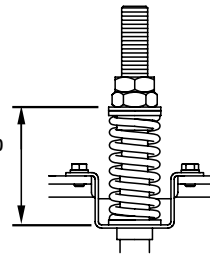

SAT XD Tensioner Pressure Chart

Blade Width		Blades	Pressure	
in.	mm		psi	kPa
18	450	3	15#	103
24	600	4	19#	131
30	750	5	23#	159
36	900	6	27#	186
42	1050	7	31#	214
48	1200	8	35#	241
54	1350	9	39#	269
60	1500	10	43#	296
72	1800	12	51#	352
84	2100	14	59#	407
96	2400	16	67#	462

- Maximum Belt Speed 800 FPM (4M/sec)
- Temperature Rating -30°F to 180°F (-35°C to 82°C)
- Available for Belt Widths 18" to 96" (450 to 2400mm). Other sizes available upon request.

Section 8 - Specs and CAD Drawings

8.2 CAD Drawing - CBS with SST XD Tensioners

SPECIFICATIONS			CBS CLEANER	
BELT WIDTH "A" (in)	POLE LENGTH "B" (in)	(mm)	ORDER NUMBER	ITEM CODE
18	72.25	1835	CBS18SF	79936
24	78.25	1988	CBS24SF	79937
30	84.25	2140	CBS30SF	79938
36	90.25	2292	CBS36SF	79939
42	105.25	2692	CBS42SF	79940
48	120.25	3045	CBS48SF	79941
54	135.25	3445	CBS54SF	79942
60	150.25	3845	CBS60SF	79943
72	180.25	4545	CBS72SF	79944
84	210.25	5312	CBS84SF	79945
96	240.25	6080	CBS96SF	79946

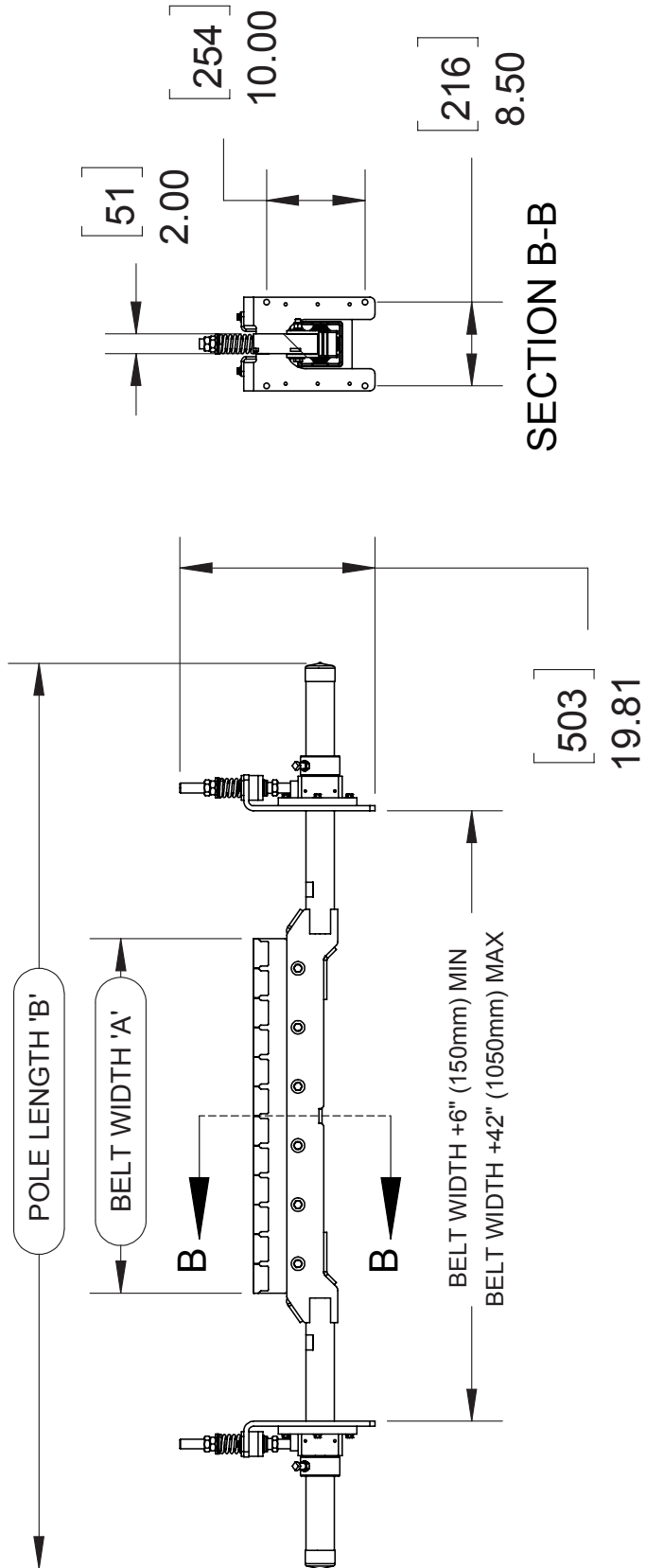

Section 8 - Specs and CAD Drawings

8.3 CAD Drawing - CBS with SAT XD Tensioners

SPECIFICATIONS			CBS CLEANER		
BELT WIDTH "A"		POLE LENGTH "B"		ORDER NUMBER	ITEM CODE
(in)	(mm)	(in)	(mm)		
18	480	73	1854	CBS18PF	79958
24	600	79	2007	CBS24PF	79959
30	700	85	2159	CBS30PF	79960
36	900	91	2311	CBS36PF	79961
42	1050	97	2464	CBS42PF	79962
48	1200	103	2616	CBS48PF	79963
54	1350	109	2769	CBS54PF	79964
60	1500	115	2921	CBS60PF	79965
72	1800	127	3226	CBS72PF	79966
84	2100	139	3531	CBS84PF	79967
96	2400	151	3835	CBS96PF	79968

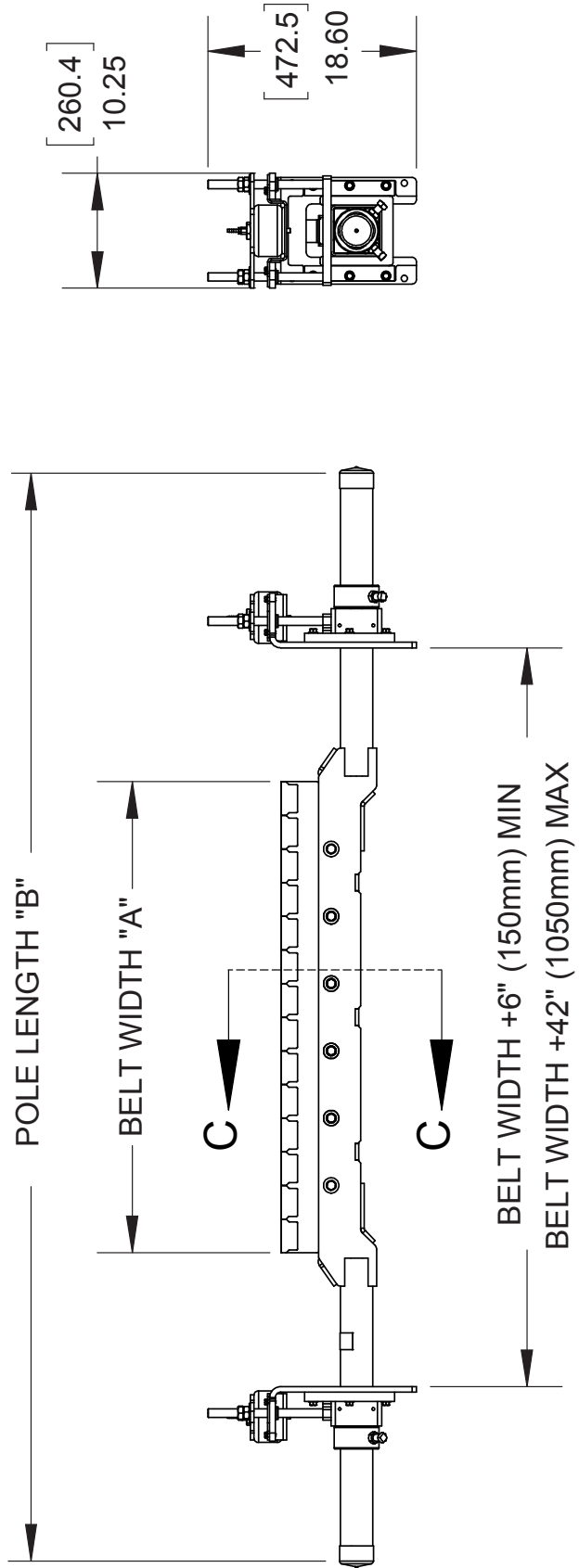
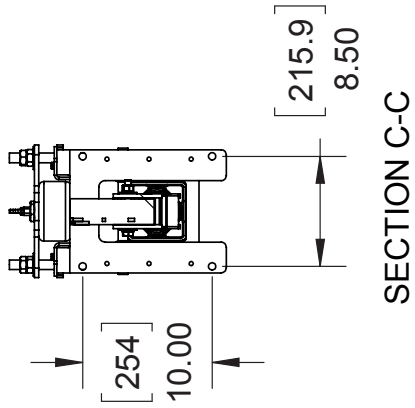

Section 9 - Replacement Parts

9.1 Replacement Parts List - CBS Secondary Cleaner

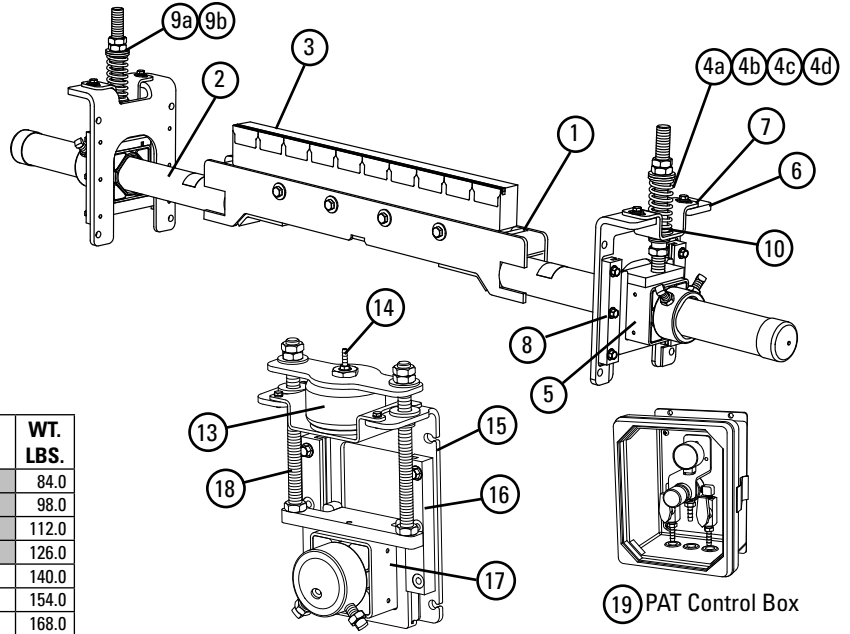
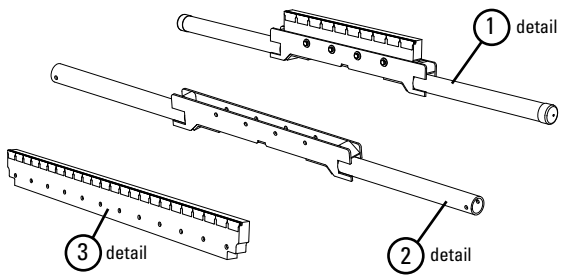

Replacement Parts

REF	DESCRIPTION	ORDERING NUMBER	ITEM CODE	WT. LBS.
1	18" (450mm) CBS Blade/Pole Flat	CBSBP18F	90101	84.0
	24" (600mm) CBS Blade/Pole Flat	CBSBP24F	90102	98.0
	30" (750mm) CBS Blade/Pole Flat	CBSBP30F	90103	112.0
	36" (900mm) CBS Blade/Pole Flat	CBSBP36F	90104	126.0
	42" (1050mm) CBS Blade/Pole Flat	CBSBP42F	90105	140.0
	48" (1200mm) CBS Blade/Pole Flat	CBSBP48F	90106	154.0
	54" (1350mm) CBS Blade/Pole Flat	CBSBP54F	90107	168.0
	60" (1500mm) CBS Blade/Pole Flat	CBSBP60F	90108	182.0
	72" (1800mm) CBS Blade/Pole Flat	CBSBP72F	90109	210.0
	84" (2100mm) CBS Blade/Pole Flat	CBSBP84F	90110	238.0
96" (2400mm) CBS Blade/Pole Flat	CBSBP96F	90111	266.0	
2	18" (450mm) CBS Repl Pole	CBSP18	91432	68.0
	24" (600mm) CBS Repl Pole	CBSP24	91433	76.0
	30" (750mm) CBS Repl Pole	CBSP30	91434	85.0
	36" (900mm) CBS Repl Pole	CBSP36	91435	93.0
	42" (1050mm) CBS Repl Pole	CBSP42	91436	101.0
	48" (1200mm) CBS Repl Pole	CBSP48	91437	109.0
	54" (1350mm) CBS Repl Pole	CBSP54	91438	118.0
	60" (1500mm) CBS Repl Pole	CBSP60	91439	126.0
	72" (1800mm) CBS Repl Pole	CBSP72	91440	143.0
	84" (2100mm) CBS Repl Pole	CBSP84	91441	159.0
96" (2400mm) CBS Repl Pole	CBSP96	91442	176.0	
3	18" (450mm) CBS Blade Flat	CBSBLD18F	79947	16.0
	24" (600mm) CBS Blade Flat	CBSBLD24F	79948	22.0
	30" (750mm) CBS Blade Flat	CBSBLD30F	79949	27.0
	36" (900mm) CBS Blade Flat	CBSBLD36F	79950	33.0
	42" (1050mm) CBS Blade Flat	CBSBLD42F	79951	39.0
	48" (1200mm) CBS Blade Flat	CBSBLD48F	79952	45.0
	54" (1350mm) CBS Blade Flat	CBSBLD54F	79953	50.0
	60" (1500mm) CBS Blade Flat	CBSBLD60F	79954	56.0
	72" (1800mm) CBS Blade Flat	CBSBLD72F	79955	67.0
	84" (2100mm) CBS Blade Flat	CBSBLD84F	79956	79.0
96" (2400mm) CBS Blade Flat	CBSBLD96F	79957	90.0	
4a	Tension Spring - White (1 ea.) for belts 18" - 30" (450-750mm)	STS-W	75846	0.5
4b	Tension Spring - Silver (1 ea.) for belts 36" - 48" (900-1200mm)	STS-S	75843	0.8
4c	Tension Spring - Black (1 ea.) for belts 54" - 84" (1350-2100mm)	STS-B	75844	1.0
4d	Tension Spring - Gold (1 ea.) for belts 96" (2400mm)	STS-G	78142	1.3
5	HD Torsion Pole Mount* (1 ea.) (includes HD adjusting rod, nuts & sleeve) (See 9 & 9a for bushings)	SSTHDPM	77868	15.0
6	SST XD Mounting Base Kit* (includes 1 mounting base, 2 slide guides, top hat bracket & bottom bushing)	SSTXDMK	91412	10.2
7	SST Hat Bracket (pair)	SSTHB	79582	3.0
8	Slide Guide Kit* (incl. 2 slide guides)	STGK2	77867	1.1
9a	SST Bushing Kit - White/Silver (includes 2 bushings)	SSTBK-W	76636	0.1
9b	SST Bushing Kit - Black/Gold (includes 2 bushings)	SSTBK-B	76637	0.1
10	SST Lower Bushing Kit (pair)	SSTLBK	79493	.2

*Hardware Included
Lead time: 1 day; shaded items 3 weeks

- 11 Secondary Air Tensioner XD with Control Box
- 12 Secondary Air Tensioner XD w/o Control Box

SAT XD (Secondary Air Tensioner XD) Replacement Parts

REF	DESCRIPTION	ORDERING NUMBER	ITEM CODE	WT. LBS.
11	SAT XD w/PAT Control Box	SATXDPAT	91413	43.5
12	SAT XD w/o Control Box	SATXDNCB	91414	41.0
13	SAT Air/Water Bag Kit	SATB	76083	5.1
14	SAT 1/8" Hose Barb Kit	SATHB	76084	0.1
15	SAT XD Mounting Base Kit	SAT2MK	91415	11.6
16	ST Slide Guide Kit	STGK2	77867	1.1
17	SAT2 Torsion Pole Mount	SAT2PM	78732	11.1
18	SAT2 Adjusting Rod Kit	SAT2AK	78733	5.0
19	PAT Control Box 100psi	PACB100	79656	11.0

Lead time: 1 working day

SST XD (Secondary Spring Tensioner XD) Options

REF	DESCRIPTION	ORDERING NUMBER	ITEM CODE	WT. LBS.
-	SST XD Spring Tensioner* - White (includes 2 each items 4a, 5, 6, & 9a) for belts 18" - 30" (450-750mm)	SSTXD-W	91408	60.6
-	SST XD Spring Tensioner* - Silver (includes 2 each items 4b, 5, 6, & 9a) for belts 36" - 48" (900-1200mm)	SSTXD-S	91409	61.4
-	SST XD Spring Tensioner* - Black (includes 2 each items 4c, 5, 6, & 9b) for belts 54" - 84" (1350-2100mm)	SSTXD-B	91410	62.0
-	SST XD Spring Tensioner* - Gold (includes 2 each items 4d, 5, 6, & 9b) for belts 96" (2400mm)	SSTXD-G	91411	62.6

Spring Tensioner Selection Chart

CLEANER SIZE	91408 SSTXD-W	91409 SSTXD-S	91410 SSTXD-B	91411 SSTXD-G
CBS 18" - 30" (450 - 750mm)	X			
CBS 36" - 48" (900 - 1200mm)		X		
CBS 54" - 84" (1350 - 2100mm)			X	
CBS 96" (2400mm)				X



Section 10 - Other Flexco Conveyor Products

Flexco provides many conveyor products that help your conveyors to run more efficiently and safely. These components solve typical conveyor problems and improve productivity. Here is a quick overview on just a few of them:

MMP Precleaner



- Extra cleaning power right on the head pulley
- A 10" (250mm) TuffShear™ blade provides increased blade tension on the belt to peel off abrasive materials
- The unique Visual Tension Check™ ensures optimal blade tensioning and quick, accurate retensioning
- Easy to install and simple to service

DRX Impact Beds



- Exclusive Velocity Reduction Technology™ to better protect the belt
- Slide-Out Service™ gives direct access to all impact bars for change-out
- Impact bar supports for longer bar life
- 4 models to custom fit to the application

MDWS DryWipe Secondary Cleaner



- Wipes the belt dry as final cleaner in system
- Automatic blade tensioning to the belt
- Easy, visual blade tension check
- Simple, one-pin blade replacement

PT Max™ Belt Trainer



- Patented "pivot & tilt" design for superior training action
- Dual sensor rollers on each side to minimize belt damage
- Pivot point guaranteed not to freeze up
- Available for topside and return side belts

Flexco Specialty Belt Cleaners



- "Limited space" cleaners for tight conveyor applications
- High Temp cleaners for severe, high heat applications
- A rubber fingered cleaner for chevron and raised rib belts
- Multiple cleaner styles in stainless steel for corrosive applications

Belt Plows



- A belt cleaner for the tail pulley
- Exclusive blade design quickly spirals debris off the belt
- Economical and easy to service
- Available in vee or diagonal models

The Flexco Vision

To become the leader in maximising
belt conveyor productivity for our customers worldwide
through superior service and innovation.

2525 Wisconsin Avenue • Downers Grove, IL 60515-4200 • USA
Tel: (630) 971-0150 • Fax: (630) 971-1180 • E-mail: info@flexco.com

Visit www.flexco.com for other Flexco locations and products.

©2019 Flexible Steel Lacing Company. 05/22/19. For reorder: X3971

