

FGP Food Grade Precleaner

USDA Certified Precleaner Meets Highest Standards for Food Processing Applications

The FGP Food Grade Precleaner from Flexco is easy to install, easy to maintain, and disassembles in a snap for regular cleaning and sanitisation. The FGP Precleaner works on any belt from 100 mm to 1500 mm (4" to 60") and the blade is available in white, blue, metal detectable blue, and dual durometer blue FDA approved food grade material.

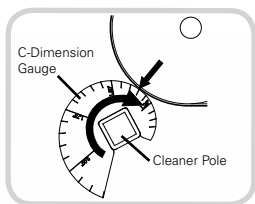

C-Dimension verification gauge makes it easy to set the proper pole location for optimal cleaner performance—the four optional mounting bracket designs help simplify complex installation



Cleaner blades are available in blue, white, dual durometer blue, and metal detectable blue



The FGP Precleaner is:

- Made from FDA approved materials
- USDA certified
- Compliant with EU 1935/2004 Food Contact Regulation
- Accepted by Health Canada

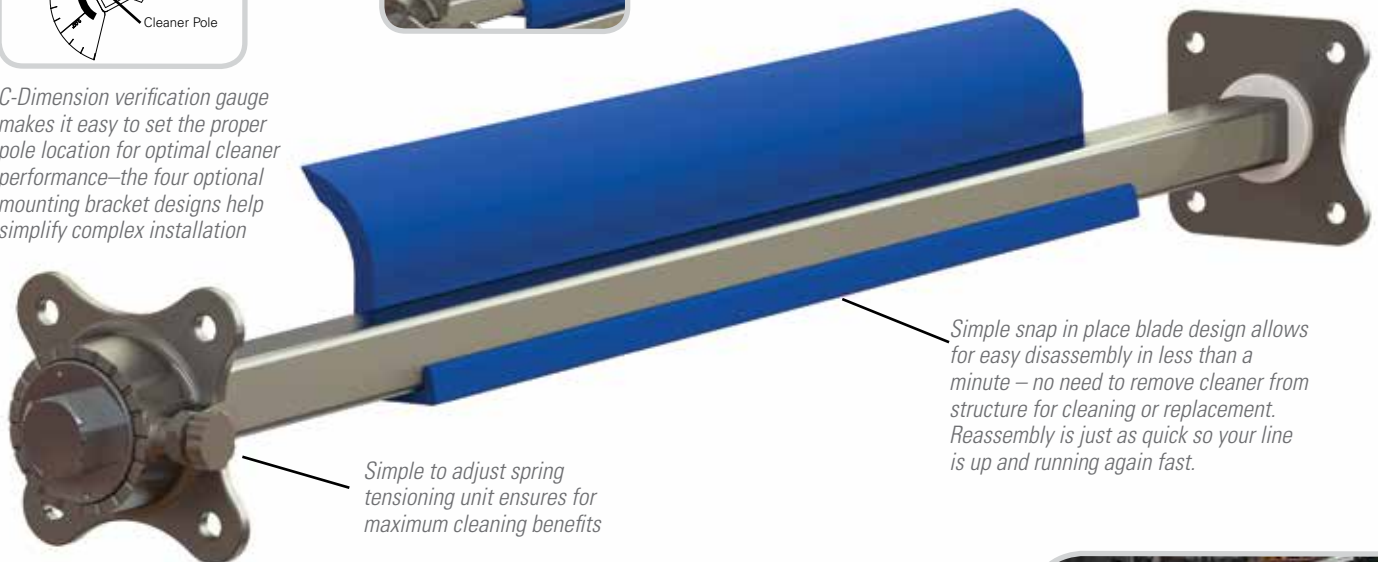

Simple to adjust spring tensioning unit ensures for maximum cleaning benefits

Simple snap in place blade design allows for easy disassembly in less than a minute – no need to remove cleaner from structure for cleaning or replacement. Reassembly is just as quick so your line is up and running again fast.

Features and Benefits:

- **Minimal hardware** so installation, tensioning, and blade replacement are easy.
- **Simple design** with stainless steel components and food grade materials limit crevices and opportunities for bacteria growth.
- **Easily tensioned** to minimise blade wear, eliminate belt damage, and maximise cleanability.
- **Optional metal detectable blue blade** for additional protection against food contamination.
- **Dual durometer blade** with metal detectable tip for uneven or soft cover belts.
- **Available in standard blade widths** for belts from 300 mm to 1500 mm (12" to 60"). Blades can be cut down to appropriate length.
- **Compatible** with endless and mechanical splices. Suitable for use on modular belting.



Patents: D776,396 and 0029948222-0001

FGP Food Grade Precleaner

Specifications:

- **Temperature Range**
UHMW:
-29°C to 60°C (-20°F to 140°F)
Dual Durometer:
0°C to 60°C (+32°F to 140°F)
- **Blade Height**
76 mm (3.0")
- **Blade Width Range**
102 to 1524 mm
(4" to 60")
- **Pole/Mounting Material**
304 Stainless Steel
- **Blade Hardness**
UHMW:
63D Shore Hardness
Urethane:
85A Shore Hardness
- **Pulley Diameter Range**
50 to 267 mm (2" to 10.5")
- **Blade Material**
Food-grade UHMW, UHMW
with Stainless Steel, or
Urethane with PVC

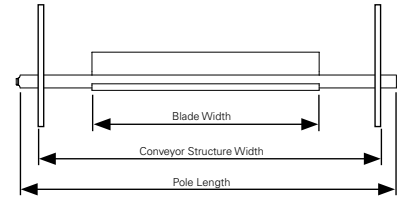

How to choose the correct size blade for your conveyor.

1. Measure your belt width.
2. Choose the Blade Width that corresponds to your belt width.
3. Measure your conveyor width.
4. Verify the Maximum Conveyor Width shown in the selection chart is larger than your conveyor width. If your conveyor width is smaller than the maximum width shown, choose the next larger blade width that accommodates your conveyor width.
5. Blade and/or pole can be cut to users required length. Pole must be 50 mm (2") longer than the outside width of conveyor structure at the mounting location.

Pole Lengths									
Pole Length		Standard Blade Length		Minimum Blade Length		Minimum Conveyor Width at Cleaner Mounting Location		Maximum Conveyor Width at Cleaner Mounting Location	
mm	in.	mm	in.	mm	in.	mm	in.	mm	in.
610	24	305	12	229	9	279	11	556	22
813	30	457	18	229	9	356	14	708	28
965	36	610	24	229	9	508	20	861	34
1067	42	813	30	457	18	660	26	1013	40
1219	48	965	36	457	18	813	32	1165	46
1372	54	1067	42	457	18	965	38	1318	52
1524	60	1219	48	457	18	1118	44	1470	58
1676	66	1372	54	457	18	1270	50	1623	64
1829	72	1524	60	457	18	1422	56	1775	70

*Pole length = blade length + 305 mm (12") on standard cleaners.

FGP Food Grade Precleaner

Blade Width		Maximum Conveyor Width		Weight		White Blade		Blue Blade		Blue Metal Detectable Blade		Blue Dual Durometer Blade*	
mm	in.	mm	in.	kg.	lbs.	Ordering Number	Item Code	Ordering Number	Item Code	Ordering Number	Item Code	Ordering Number	Item Code
305	12	559	22	3.0	6.7	FGP-W3-12	56009	FGP-BL3-12	56000	FGP-MD3-12	56027	FGP-MDDD3-12	56018
457	18	711	28	3.5	7.7	FGP-W3-18	56010	FGP-BL3-18	56001	FGP-MD3-18	56028	FGP-MDDD3-18	56019
610	24	864	34	3.9	8.6	FGP-W3-24	56011	FGP-BL3-24	56002	FGP-MD3-24	56029	FGP-MDDD3-24	56020
762	30	1016	40	4.3	9.5	FGP-W3-30	56012	FGP-BL3-30	56003	FGP-MD3-30	56030	FGP-MDDD3-30	56021
914	36	1168	46	4.8	10.5	FGP-W3-36	56013	FGP-BL3-36	56004	FGP-MD3-36	56031	FGP-MDDD3-36	56022
1067	42	1321	52	5.2	11.5	FGP-W3-42	56014	FGP-BL3-42	56005	FGP-MD3-42	56032	FGP-MDDD3-42	56023
1219	48	1473	58	5.6	12.4	FGP-W3-48	56015	FGP-BL3-48	56006	FGP-MD3-48	56033	FGP-MDDD3-48	56024
1372	54	1626	64	6.0	13.3	FGP-W3-54	56016	FGP-BL3-54	56007	FGP-MD3-54	56034	FGP-MDDD3-54	56025
1524	60	1778	70	6.4	14.2	FGP-W3-60	56017	FGP-BL3-60	56008	FGP-MD3-60	56035	FGP-MDDD3-60	56026

*Dual durometer blade is not compliant with Health Canada or EU 1935/2004.

FGP Optional Mounting Brackets (Bolt or Weld)

Description	Ordering Number	Item Code
1 Frame Mount	FGP-MOUNT-FRAME	56585
2 Flange Bearing Mount	FGP-MOUNT-FLANGE-BEARING	56586
3 Base Bearing Mount	FGP-MOUNT-BASE-BEARING	56587
4 Two-Piece Mount	FGP-MOUNT-TWO-PIECE	56588

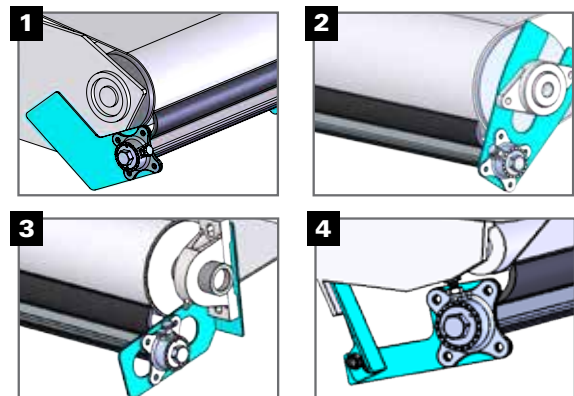

Authorised Distributor:

No. 71, Vanagaram Village • Ambattur Taluk, Thiruvallur District • Chennai, Tamilnadu – 600 095 • India
Tel: +91-44-6551-7771 • E-mail: info.india@flexco.com

Visit www.flexco.com for other Flexco locations and products.

