

FMS Secondary Cleaner

Reliable Cleaning at an Affordable Price

The FMS Secondary Belt Cleaner features carbide blades, self-adjusting spring tensioners and unique cushions that independently tension each blade to the belt. This simple but durable design provides quality cleaning performance at an affordable price.

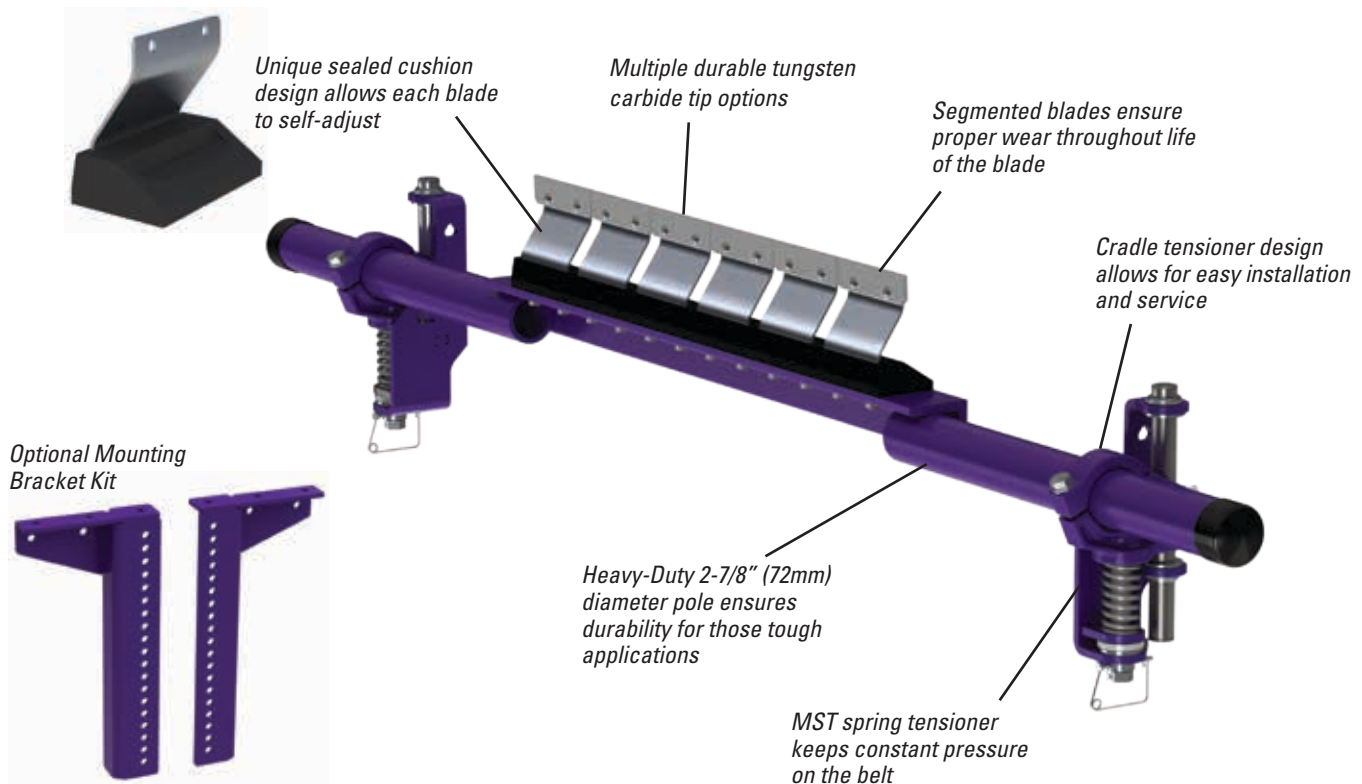

Features and Benefits

- **Made for mining conveyors.** Made from heavy-duty steel with corrosion-resistant powder coating, the FMS is available in sizes for belt widths from 18" to 72" (450 to 1800mm). Additional sizes are available upon request.
- **For belt speeds up to 1000 fpm (5M/s).**
- **Compact spring tensioner.** Utilizes the MST tensioner to maintain constant pressure on the belt.
- **Cleaning efficiency of metal blades.** The thin, hard edges of the 6" (150mm) wide metal blades deliver high cleaning efficiency and long wear life.
- **Works with Flexco mechanical splices.** The C-Tip tungsten carbide blades are impact-resistant, and the spring cushion allows them to move away from a passing splice without damage and with minimal cleaning disruption. V-Tips can be used only on vulcanized belts.
- **A complete cleaning system.** When the FMS is teamed with the MSP or MMP Precleaner the system provides excellent cleaning power for tough applications.

FMS Secondary Cleaner

Specifications and Guidelines

Maximum Belt Speed

1000 FPM (5 m/s)

Temperature Rating

-30° F to 180° F (-35° C to 82° C)

Usable Blade Wear Length

3/8" (9 mm)

Available for Belt Widths

18" to 72" (450 to 1800 mm)

Blade Material

Impact resistant, long-lasting tungsten carbide (C-Tips for mechanical fasteners, V-Tips for vulcanized belts)

CEMA Cleaner Rating

Class 4

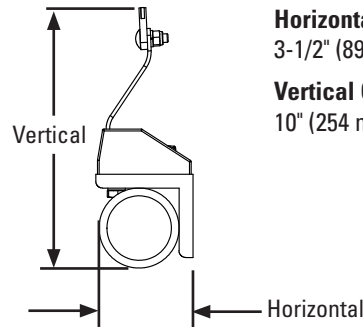

Horizontal Clearance Required

3-1/2" (89 mm)

Vertical Clearance Required

10" (254 mm)

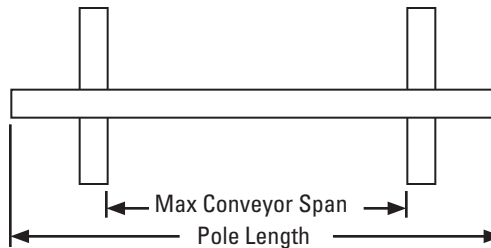

Pole Length

Belt width + 54" (1350 mm)

Maximum Conveyor Span

Belt width + 44" (1100 mm)

Ordering Information

FMS Secondary with C-Tips

Belt Width		Complete Cleaner	
in.	mm	Ordering Number	Item Code
18	450	FMS-18	79637
24	600	FMS-24	79638
30	750	FMS-30	79639
36	900	FMS-36	79640
42	1050	FMS-42	79641
48	1200	FMS-48	79642
54	1350	FMS-54	79643
60	1500	FMS-60	79644
72	1800	FMS-72	79645

Lead time: 1 working day

FMS Secondary with V-Tips

Belt Width		Complete Cleaner	
in.	mm	Ordering Number	Item Code
18	450	FMS-18V	79646
24	600	FMS-24V	79647
30	750	FMS-30V	79648
36	900	FMS-36V	79649
42	1050	FMS-42V	79650
48	1200	FMS-48V	79651
54	1350	FMS-54V	79652
60	1500	FMS-60V	79653
72	1800	FMS-72V	79654

Lead time: 1 working day



FMS Secondary Cleaner

Replacement Tips

Ordering Number	Item Code
ICT6 (C-Tip)	74535
RSA150 (V-Tip)	73628

Replacement Cushion

Ordering Number	Item Code
FMSC	79699

Drop Bracket Kit

Ordering Number	Item Code
MSTDB	79434

Blades Required per Cleaner Size

in.	18	24	30	36	42	48	54	60	72
mm	450	600	750	900	1050	1200	1350	1500	1800
Blades Required	3	4	5	6	7	8	9	10	12

Authorized Distributor:



2525 Wisconsin Avenue • Downers Grove, IL 60515-4200 • USA
Tel: (630) 971-0150 • Fax: (630) 971-1180 • E-mail: info@flexco.com

Visit www.flexco.com for other Flexco locations and products.

©2019 Flexible Steel Lacing Company. 11/13/19. For reorder: X3865

